

Product Document

**high
performance
needs great
design.**

Coverpage: AS89010-EB1 Datasheet

Please be patient while we transfer this adapted former MAZeT document to the latest ams design.

DATASHEET

AS89010-EB1

AS89010 Evaluation Board with I²C Interface

Order No.: 220820002

Status: preliminary

FEATURES

Amplifier and converter AS89010:

- Conversion of 4 sensor signals of external or customized mounted photodiodes or other sensors with current signal output
- Configurable conversion gain and integration time supports a very high dynamic range of 1 – 1,000,000
- Up to 16 bit signal resolution by achievable sensitivity up to 20 fA/LSB
- Adjustable operation modes like continuous, by command and externally synchronized (by given start and start/end signal) measurement
- Option: external control of integration time and reference current (gain)
- High linearity of amplifying, no cross talking
- High absolute accuracy without additional sources
- High reliability internal reference source generation
- Option: consideration of negative offset
- Measurement of current for both polarities
- Measurement of integration time
- Supply and temperature independent response
- Inherent ripple rejection of the 50 Hz/60 Hz external disturbances
- 16 Bit/400 kHz fast I²C Interface with programmable slave addresses
- Very low current consumption in active, in *Power Down* and *Standby* mode

Test board:

- Alternative variants to mount/connect maximal 4 external photodiodes and sensors
- Temperature sensor and memory on board
- Supply voltage 3,3 V to 5 V
- Individual addressing for I²C communication
- Extra test points on board
- Temperature range -25°C to 100°C
- Standard I²C interface
- Expandable as test kit with USB-Interface, test software and JENCOLOR[®] software library

APPLICATIONS

- Evaluation, test and start system for feasibilities and benchmarks and/or OEM sensor board for 1...4 photo sensors in combination with ams Sensors Germany's AS89010
- Precise conversion of average e.g. integral photo current for optical sensors and arrays (e.g. UV, VIS, IR) and other sensors with current output

FEATURES 1

APPLICATIONS 1

1 GENERAL DESCRIPTION 3

2 HARDWARE 5

 2.1 Customized Mounted Photo Diodes 6

 2.2 Current-to-Digital-Converter AS89010 6

 2.3 Memory 7

 2.4 Temperature Sensor 7

 2.5 Power Supply 7

 2.6 Hardware Interface & Test Points 7

3 MAXIMUM CONDITIONS 8

4 APPLICATION NOTES 9

5 DEVELOPMENT KIT SET AS89010 9

6 NOTES 10

7 REFERENCE DOCUMENTS 10

ORDERING INFORMATION 11

LEGAL NOTES AND WARNINGS 12

PRELIMINARY

1 GENERAL DESCRIPTION

The evaluation board AS89010-EB1 is a small PCB for testing the AS89010 of ams Sensors Germany in combination with maximal 4 customized mounted photo diodes. Besides these diodes the sensor board includes the 4 channel analog-to-digital converter AS89010 [1] with a high dynamic range, an EEPROM for sensor data's, power regulator and an I²C-interface.

I²C is used for external communication, configuration, and readout of the sensor data as well as reading and writing of the memory. Figure 1 shows the block diagram. Table 1 is a listing of the essential side parameter.

Figure 2 shows the PCB with the most important elements and interfaces. In Figure 3 are the sizes of the board.

Figure 1: Block diagram AS89010-EB1 ADC Evaluation board with customized mounted sensors

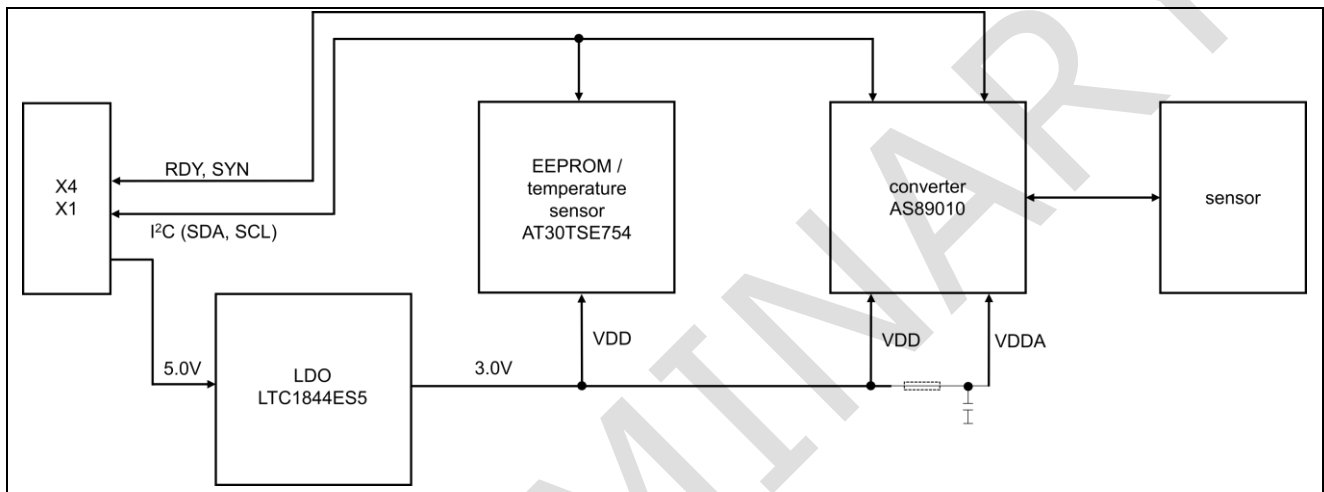

Table 1: Overview of the essential components and parameter

NAME	AS89010-EB1								
H1...H4 Sensors	The development board includes pre-defined solder points for fitting customized photodiodes								
U1 Signal amplification (Low light until lightning amplification)	AS89010 input currents: 20 nA...5 µA sensitivity up to 20 fA/LSB – dynamic range 1 – 1,000,000 Internal ADC converter 16 bit								
U3 Power Supply	3,3 V -5% up to 5 V +10%								
U2 Memory size	512 byte								
U2 Temperature Sensor	Accuracy ±0.5°C @ 0...85°C Accuracy ±2°C @ -40°C...125°C								
X1 Electronic Interface WE-MM Connector	Fitted Standard I ² C - for communication <table border="0" style="width: 100%;"> <tr> <td>1 X1 RDY</td> <td>5 X1 SCL</td> </tr> <tr> <td>2 Ground</td> <td>6 Ground</td> </tr> <tr> <td>3 X1 SYN</td> <td>7 X1 SDA</td> </tr> <tr> <td>4 Ground</td> <td>8 VDD</td> </tr> </table>	1 X1 RDY	5 X1 SCL	2 Ground	6 Ground	3 X1 SYN	7 X1 SDA	4 Ground	8 VDD
1 X1 RDY	5 X1 SCL								
2 Ground	6 Ground								
3 X1 SYN	7 X1 SDA								
4 Ground	8 VDD								
X2, X3 Address Jumper	Individual addressing for I ² C communication								

NAME		AS89010-EB1	
X4 Electronic Interface ZIF Connector	Optional standard I ² C - for communication		
	1 X1 RDY	5 X1 SCL	
	2 Ground	6 Ground	
	3 X1 SYN	7 X1 SDA	
	4 Ground	8 VDD	
X5 Electronic Interface	Optional addressing photo diodes for receptacle pitch		
	1 Anode 1	5 Anode 3	
	2 Common cathode	6 Common cathode	
	3 Anode 2	7 Anode 4	
	4 Common cathode	8 Common cathode	
Test points	P9 GND	P13 X1 SYN	
	P10 X1 RDY	P14 VDD	
	P11 X1 SDA	P15 GND	
	P12 X1 SCL		

Figure 2: PCB overview (Front and rear panel)

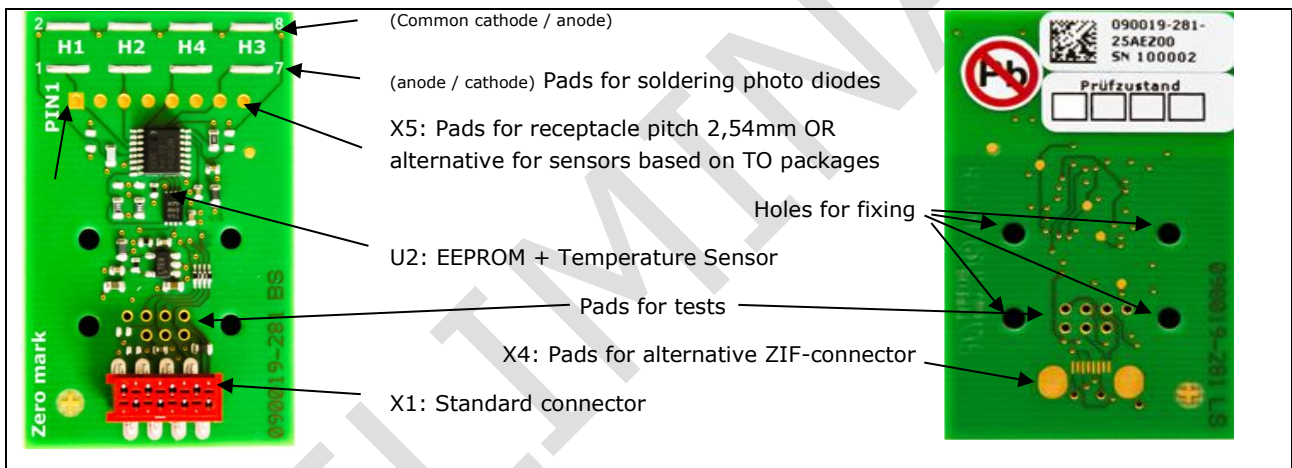
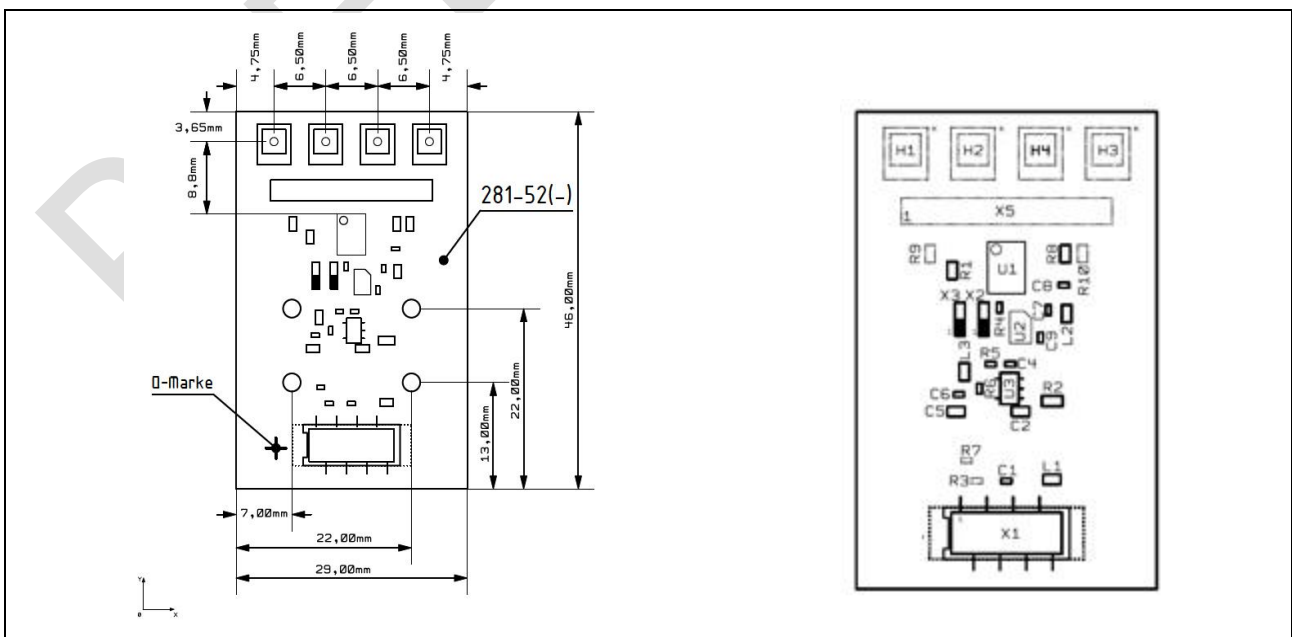

Figure 3: PCB components, dimensions and notifications



2 HARDWARE

Figure 4 shows the schematic and pinning of the connectors. The following chapters describe the typical main components of the AS89010-EB1.

Figure 4: Schematic of reference design

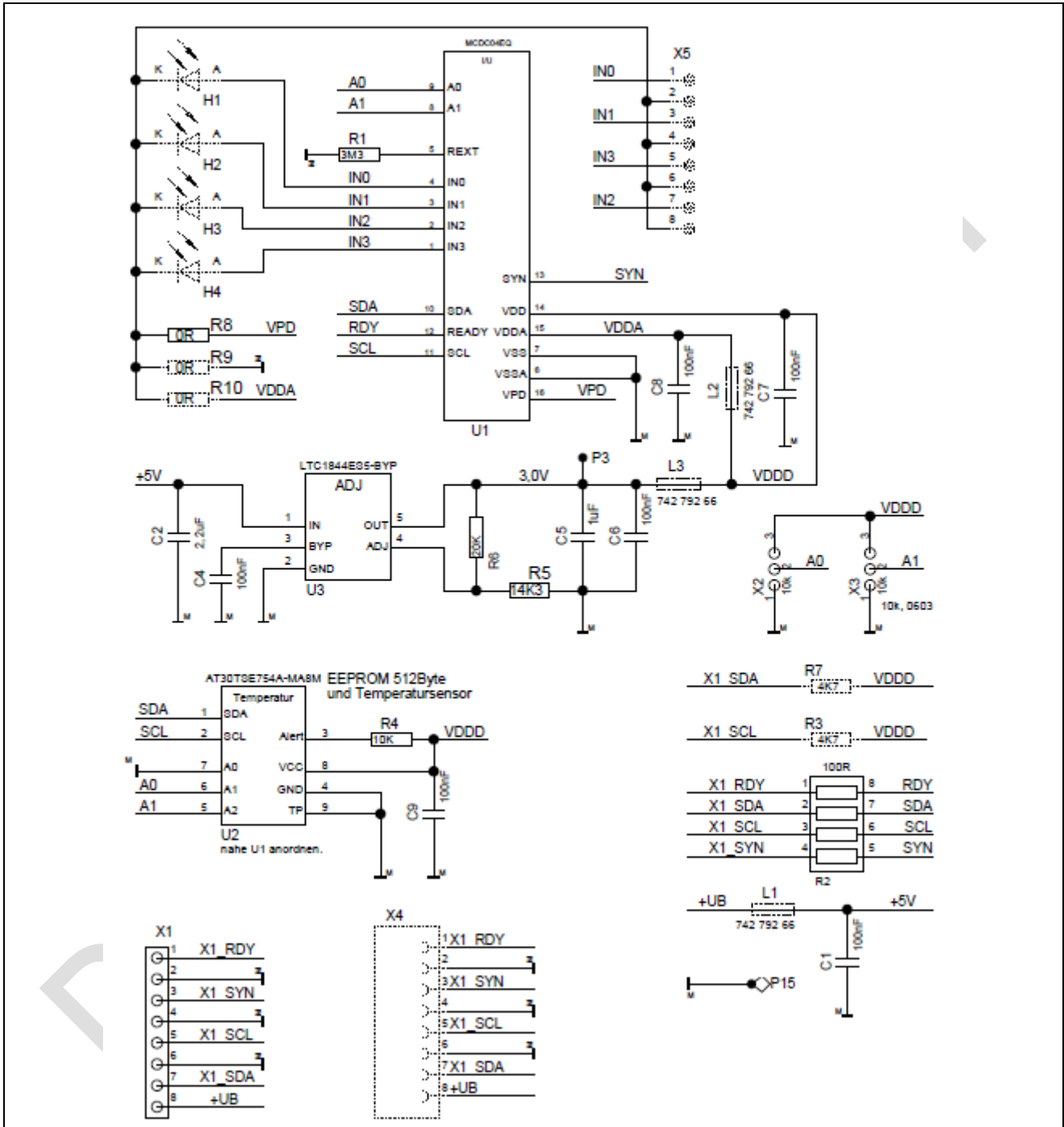

Please note, on board are some special schematics and external to be assembled components to stabilize power supply and (references, filter chokes and capacitors) other preconditions. More details are described in [1].

2.1 Customized Mounted Photo Diodes

On the MCD04-EB1 alternative positions are possible to mount customized photo diodes. Use the positions H1...H4 (SMD packages) or holes on position X5 (TO packages) for soldering the diodes with common cathode or anode and/or the connector X5 in combination with a flat ribbon cable to connect an external board solution.

The potential for the common cathode/anode and so the operation mode will be determined by the soldering zero Ohm resistors R8, R9 or R10 (see Figure 4). At the factory on board the resistor R8 (VPD for Zero Bias Mode) is soldered. Please use R10 for VDDA for the Reverse Bias Mode and R9 in case of a common anode at ground.

The distances between sensors and converter should be small as possible to prevent interferences. Use only shielded connections between sensor and converter and work with the sensor system in a metallic EMC safe package.

The evaluation board is ready for measurements after soldering the photodiodes or connection of an external sensor board via connectors.

2.2 Current-to-Digital-Converter AS89010

The on-board AS89010 is a low-power and low-noise sensor interface IC suitable for coupling multi-channel optical sensors or other sensors using current output – like AS73210 on board. The signal IC converts input currents of photodiodes to a digital output and enables a continuous or triggered measurement via current integration.

Figure 5: Block diagram AS89010

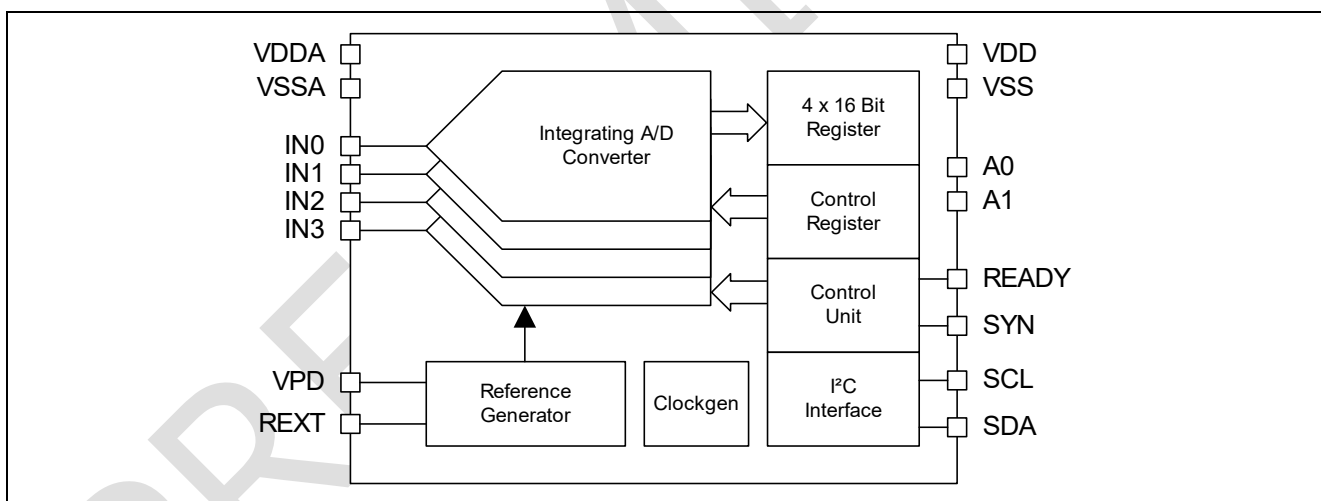

The integration time and sensitivity can be controlled by external programming. The input currents of all four signal channels are converted directly and simultaneously to a digital representation of their measured average. The channels can be divided into three signal channels and one dummy channel for compensation of parasitic currents. A configurable conversion amplification factor, integration time support and a dynamic range of 1 to 1,000,000 achieve an accuracy of up to 16 bit signal resolution at sensitivity up to 20 fA/LSB. The internal reference generation provides a high reliability.

The sensor IC also includes an inherited ripple rejection of the 50 Hz/60 Hz external disturbances and is specially designed to accommodate high accuracy at high sensitivity offering high durability. Automatic power down (sleep function) between subsequent measurements allows operations at very low current consumption. Furthermore, it allows a wide range of reference currents (1.25 nA to 5 μ A), integration times (1 ms to 1 s) and control modes via user programming. The conversion data can be accessed via I²C serial interface (16 bit/400 kHz fast I²C interface with programmable slave addresses).

Measurement of actual integration time for a full triggered measurement can be performed. The sensor IC on board achieves a high dynamic range: especially in lighting applications and in measurements of integral intensity of pulsed light and fluorescence.

For further details on the ASIC, modes of operation, the registers and the protocol for programming, the data and the I²C interface which is also valid for the AS89010-EB1 sensor board solution please refer to the data sheet of Current-to-Digital-Converter AS89010 [1].

2.3 Memory

A 512 byte EEPROM is integrated for calibration purposes and to save the sensor-typical parameters. The communication to the EEPROM is described in [3].

2.4 Temperature Sensor

The EEPROM also includes an integrated temperature sensor which operates at a range of 0...85°C with an absolute accuracy of ±0.5°C. The communication to the EEPROM is described in [2].

2.5 Power Supply

The operating voltage range (VDD at X1 Pin 8) of the AS89010-EB1 is 5 V +/- 10%. Additional ESD protection has been left out to minimize the dimensions of the circuit board.

2.6 Hardware Interface & Test Points

On board are different connectors for AS89010-EB1 in-/outputs. The connector X1 (see Table 1 and Figure 2) is used for external power supply and communication. An example of an adequate connector is 6903 6728 08 67 from Würth Elektronik. The counter part is 6901 5700 08 72 from Würth Eletronik. A flat cable with grid dimensions of 1.27 mm is used as interconnector. The maximum length is 0.5 m.

As a contacting option X4 use a ZIF connector with 0.5 mm pitch (e.g. FH12-8S-05.SH from Würth Elektronik) at the end of the backside.

A further possibility for communication like X1 and X4 is the use of the contact pads P4 to P14 (related test points, see Table 1 and Table 2).

At time of delivery the AS89010-EB1 contains no photo diodes on board. Use the positions H1...H4 for soldering SMD photo elements on board, the X5 pads for TO based elements or a simple connector with a receptacle pitch of 2,54 mm to connect an external PCB with photo diodes by flat ribbon cable (see Chapter 2.1 Table 1, Figure 2).

The amplification circuitry and memory consist of a joint I²C interface. The data structure is shown in [1] and [2].

The soldering bridges J1 and J2 allow individual addressing, which offer the possibility to have a parallel connection of up to four AS89010-EB1 (based on the EEPROM AT30TSE754).

Table 2: Pin assignment X1 and X4 and test points

PIN	LABEL	TYPE	FUNCTION	RELATED TEST POINT
1	RDY	out	ready signal AS89010	P10
2	GND		ground	P9
3	SYN	in	trigger AS89010	P13
4	GND		ground	P9
5	SCL	in	I ² C, serial clock input	P12
6	GND		ground	P9
7	SDA	in/out	I ² C, serial Data	P11
8	VDD		supply voltage	P14

Table 3: Addressing via Solder Bridge

AS89010-EB1 Board	Jumper X3 (A1)	Address A1	Jumper X2 (A0)	Address A0	I ² C-Address AS89010	I ² C-Adresse EEPROM	I ² C-Address Temperature sensor
1 (default)	1-2	0	1-2	0	xE8h	xA0h	X90h
2	1-2	0	2-3	1	xEAh	xA4h	X94h
3	<u>2-3</u>	<u>1</u>	<u>1-2</u>	<u>0</u>	<u>xECh</u>	<u>xA8h</u>	<u>X98h</u>
4	<u>2-3</u>	<u>1</u>	<u>2-3</u>	<u>1</u>	<u>xEEh</u>	<u>xACh</u>	<u>X9Ch</u>

3 MAXIMUM CONDITIONS

Table 4: Maximum conditions

FEATURE	COMMENT	UNIT	VALUE	
			min	max
T _S	Storage temperature	°C	-25	+100
T _B (functional)	Operating Temperature	°C	-25	+100
Power Supply		V	3,3 V -5%	5 V +10%

4 APPLICATION NOTES

Each ADC value (Analog-Digital Converted value) is calculated to a photocurrent ("photocurrent_nA") under consideration of (specified and used) dark current ("zero"), divider ("divider"), reference current ("refCurrent_nA") and integration time ("nClck"). These steps are performed before this value is used for any calibration or colorimetric functions. The following virtual code is used for each sensor channel value - whereas the ADC is the 16 bit read out value:

```
% Correction of bit shift (register CREGH)
% divider = 1 (off), 2, 4, 8 or 16
Adc = Adc * divider;

% Calculation of the maximum number of clocks nClck
% intTime_ms is the integration time in milliseconds (register CREGL)
bit = 10 + log2(intTime_ms);
nClck = 2^bit;

% Check of saturation
sat = nClck - 1;
if sat > 65535
    sat = 65535;
end
if Adc >= sat
    % Error! Sensor channel is saturated!
else
    % Measurement is ok.
end

% Correction of zero offset (register OPTREG)
% zero = 0 (disabled), 15, 31 or 63
Adc = Adc - zero;

% Calculation of photo current in nano ampere
photocurrent_nA = Adc * refCurrent_nA / nClck;
```

A detailed description of the sensor signal calculation is included in the data sheets of JENCOLOR® key components, white papers or application notes. Please ask our sales team for more details.

5 DEVELOPMENT KIT SET AS89010

To perform measurements via USB and PC the AS89010-EB1 must be completed by an USB converter [3] [4] and a test software [5]. In the case of an order of the SET-EB1 AS89010 the sensor board is expanded by these components.

The software supports alternative sensor boards like AS89010-EB1 but was pre-defined especially for JENCOLOR® sensors. Therefore after starting the software a special configuration file e.g. *command example 4channelsInAscOrder.csv*¹ must be loaded to prepare the software for the AS89010-EB1 sensor board. The parameters inside could be changed to adapt anything customized e.g. the reference between diode and ADC channel.

For more details to install the software and measure with it see [5].

¹ Here the line ChannelOrder prepares the software to enumerate 4 photo diodes in the sequence H1 up to H4.

Figure 6: Reading the configuration file

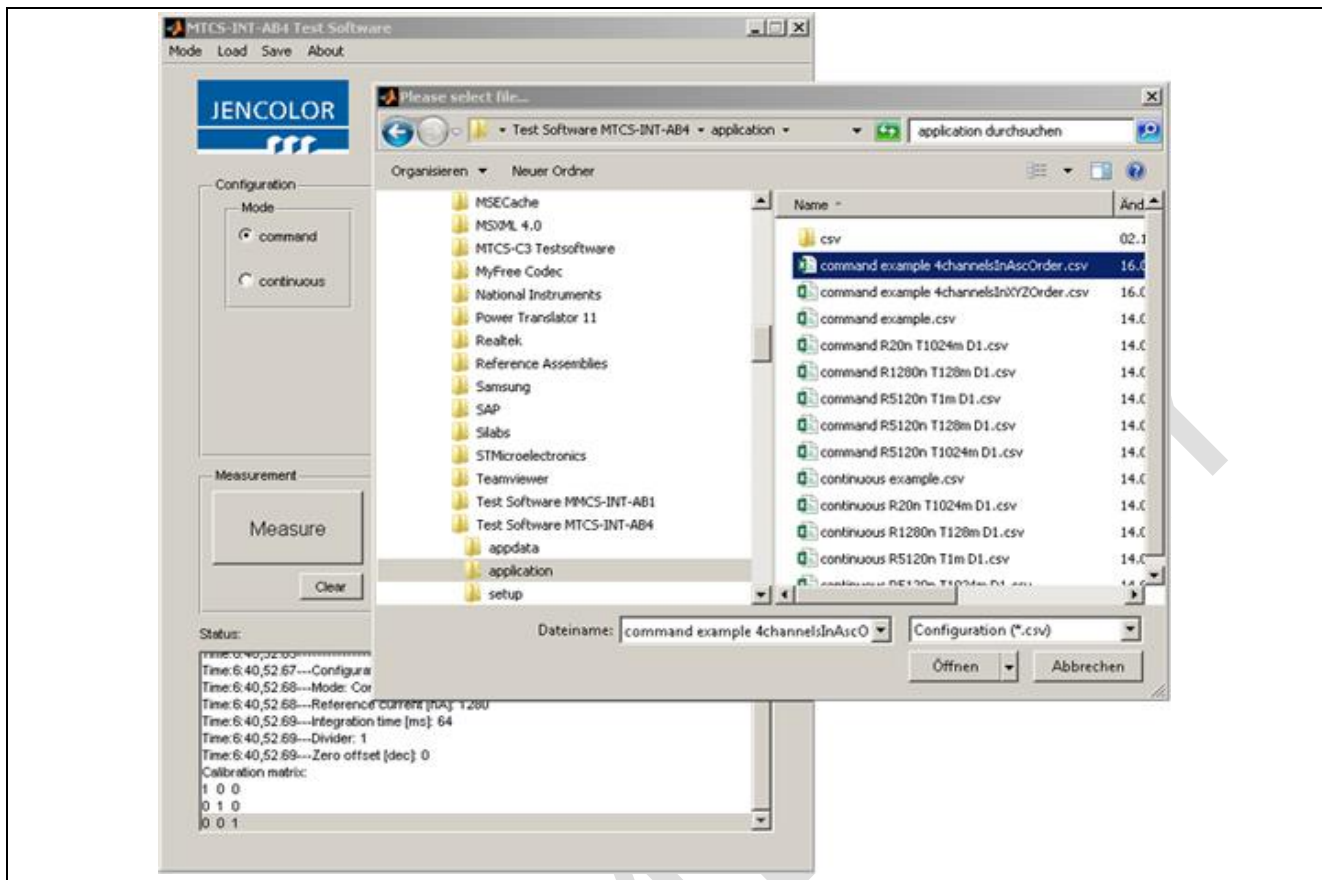

Please note any support files after installation or ask our sales team for more details.

6 NOTES

It is essential to keep the mounted sensor surface clean. Dust or scratches will adversely affect the sensor parameters. Sensors and all other electronic components should be handled with care, like all optical devices. Do not touch the bar PCB without precautions. Use the sensitive photo sensors and converter in EMC safe metallic boxes. It is important to perform normal ESD handling and precautions for ESD sensitive devices.

7 REFERENCE DOCUMENTS

- [1] AS89010 Converter data sheet
<http://www.mazet.de/en/english-documents/english/data-sheets/AS89010/download>
- [2] EEPROM AT30TSE752 8751D-DTS-8/2012 Atmel data sheet
<http://www.atmel.com/Images/doc8751.pdf>
- [3] IOW24DG Converter I²C to USB – www.codemercs.com
- [4] IO-Warrior Software
<http://www.codemercs.com/index.php?id=337&L=1>
- [5] AS73210-AS89010-AB4 SET DK Test software data sheet

ORDERING INFORMATION

NAME	STATUS	ARTICLE
AS89010-EB1	Series	220820002
SET AS89010-EB1	SET includes the following single components Including AS89010-EB1 I ² C - USB cable with dongle PC Test software Version AS73210-AS89010-AB4 SET DK	220820003

PRELIMINARY

For more information please contact:

ams Sensors Germany GmbH:

Göschwitzer Straße 32
 07745 JENA | GERMANY
 Phone: +49 3641 2809-0
 Fax: +49 3641 2809-12
 sales-europe@ams.com
 www.ams.com

LEGAL NOTES AND WARNINGS



Failure to comply with these instructions could result in death or serious injury.

Misuse of documentation – The information contained in this document is the property of ams Sensors Germany. Photocopying or otherwise reproducing any part of the catalog, whether electronically or mechanically is prohibited, except where the express permission of ams Sensors Germany GmbH has been obtained. In general, all company and brand names, as well as the names of individual products, are protected by brand, patent or product law.

State of document - The information provided in this document is for reference only. Do not use this document as product installation guide since products can be under development to improve performance or any other purpose. Before you start any development or place an order please contact your supplier or ams Sensors Germany for the latest version of this document. ams Sensors Germany explicitly reserves the right to make technical changes to information described in the document.

Information and Disclaimer – The information provided in this document is based on the knowledge of the ams Sensors Germany GmbH as of the date of publication. The ams Sensors Germany GmbH cannot give warranty regarding the accuracy of information provided by third parties. ams Sensors Germany may not have conducted testing or chemical analysis on all incoming material or chemicals. ams Sensors Germany GmbH performs and continues to perform reasonable measures to provide the most accurate data at the given time. Additional efforts to integrate information provided by third parties are performed and continue to be performed. Certain supplier information may be proprietary or limited and not available at release.



Personal Injury: All products are conform to the specifications in accordance with the terms and conditions of ams Sensors Germanys standard warranty. Production processing does not necessarily include testing of all parameters.



RoHS Directive 2011/65/EU /REACH INFORMATION - RoHS compliance and PB free: The products of ams Sensors Germany fully comply with the current RoHS-directives. Our semiconductor products do not contain any of the six substance chemical categories, for example including the restriction on lead usage (lead weight may not exceed 0.1% in homogeneous materials). RoHS compliant products are suitable for the usage in lead-free specified processes, when designed to be soldered at high temperatures.

REACH information: ams Sensors Germany products do not contain any of the latest REACH Substances of Very High Concern (SVHC) regarding the Europe Union (EU) Regulation 1907/2006. The latest 155 substances restricted per the REACH Regulation were last updated on June 16, 2014. Please refer to the following for the most current candidate list of substances: <http://echa.europa.eu/candidate-list-table>.



ams Sensors Germany solutions are not designed or intended for use in critical applications, in which the failures or malfunctions of the product may result in personal injury or death. Use of ams Sensors Germany products in life support systems is expressly unauthorized and any use by customer is completely at their own risk. In the case of a restricted use of the product described here, an application of the product outside of this limitation is at your own risk.

Warranty disclaimer – The warranty expressed herein shall be in lieu of any other warranties, expressed or implied, including, without limitation, any implied warranties or conditions of merchantability and fitness for a particular purpose., which are expressly disclaimed, and is in lieu of any and all other obligations or liability on supplier's part- For the avoidance of doubt, supplier shall not be liable for any special, incidental, indirect or consequential loss or damage, including loss of revenue or profit, of any kind of nature, arising at any time, from any cause whatsoever resulting from the use or operation of the products or any breach of this limited warranty.

Legal liability - ams Sensors Germany assumes no responsibility for the use of any foreign products or circuits described in this document or customer product design, conveys no license, either expressed or implied, under any patent or other right, and makes no representation that the foreign circuits are free of patent infringement. ams Sensors Germany further makes no claim as to the suitability of its products for any particular purpose, nor does ams Sensors Germany assume any liability arising out of the use of any product or circuit, and specifically disclaims any and all liability, including without limitation consequential or incidental damages.



ESD Warning: Sensor handling precautions should be observed to avoid static discharge.



WEEE Disposal: - The product should be disposed in to according the Directive 2002/96 / EC of the European Council on Waste Electrical and Electronic Equipment [WEEE] and the German electoral law [ElektroG] of 16 March 2005. Please contact our technical support if you need more details.