

AD-A256 035



1

VALIDATION OF AN AUTOMATED
TORSIONAL AND WARPING STRESS
ANALYSIS PROGRAM

DTIC
ELECTE
OCT 8 1992
S C D

A Special Research Problem

Presented to

The Faculty of the School of Civil Engineering
Georgia Institute of Technology

By

Stephen Mark Azzinari
Lieutenant, Civil Engineer Corps
United States Navy

19 August 1992

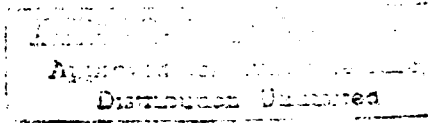

In partial fulfillment
of the Requirements for the Degree of
Master of Science in Civil Engineering

92 9 29 073

411354

92-26184



358pg

GT

GEORGIA INSTITUTE OF TECHNOLOGY
A UNIT OF THE UNIVERSITY SYSTEM OF GEORGIA
SCHOOL OF CIVIL ENGINEERING
ATLANTA, GEORGIA 30332

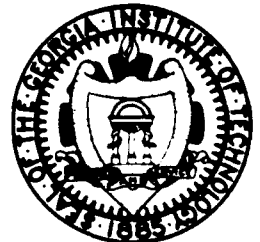

VALIDATION OF AN AUTOMATED
TORSIONAL AND WARPING STRESS
ANALYSIS PROGRAM

A Special Research Problem

Presented to

The Faculty of the School of Civil Engineering
Georgia Institute of Technology

By

Stephen Mark Azzinari
Lieutenant, Civil Engineer Corps
United States Navy

19 August 1992

In partial fulfillment
of the Requirements for the Degree of
Master of Science in Civil Engineering

Approved:

for 
Dr. Lawrence F. Kahn
Faculty Advisor

Date 8/26/92

Accession For	
NTIS Grant	<input checked="" type="checkbox"/>
DTIC TAB	<input type="checkbox"/>
Unannounced	<input type="checkbox"/>
Justification	
By	
Distribution/	
Availability Codes	
Dist	Avail and/or Special
A-1	

DTIC QUALITY INSPECTED 1

ABSTRACT

An automated procedure for determining warping and torsional stresses in open steel members was developed by Joseph Palacak, Jr. in 1985. His FORTRAN program, called "TORSION", determined stresses in wide flange, channel, and single angle members under various longitudinal bending and torsional loadings.

In order to validate the "TORSION" program, twelve test cases were run and compared to the same cases analyzed using a commonly used manual technique. For this manual technique, the Torsional Analysis Case Charts developed by Bethlehem Steel were used to compute warping and torsional stresses. Tables comparing the calculated stresses by the "TORSION" program and the torsion tables were developed.

In addition, stress values from the hand-calculated problems were compared to values from GTSTRUDL output. Comparison tables between GTSTRUDL and the hand-calculated values are also presented.

TABLE OF CONTENTS

	Page
Abstract.....	ii
Table of Contents.....	iii
 Chapter	
1 INTRODUCTION.....	1
1.1 Purpose and Objectives.....	1
1.2 Scope.....	1
1.3 Background.....	2
2 DEVELOPMENT OF HAND-CALCULATED TEST PROBLEMS.....	7
2.1 General.....	7
2.2 Torsional Analysis Case Charts.....	8
2.3 Determination of Plane Bending, Torsional and Warping Stresses	9
3 "TORSION" PROGRAM FOR STRESS ANALYSIS.....	13
3.1 General.....	13
3.2 Input and Output Files.....	14
4 COMPARISON OF "TORSION" PROGRAM AND HAND-CALCULATED STRESS RESULTS	15
4.1 General.....	15
4.2 "TORSION"/Hand-Calculation ϕ , ϕ' , ϕ'' and ϕ'''	15
Comparison Tables	
4.3 "TORSION"/Hand-Calculation Stress Comparison Tables..	30
5 "GTSTRU DL" STRESS ANALYSIS.....	57
5.1 General.....	57
5.2 GTSTRU DL Program Input and Output Files.....	57
5.3 Comparison of GTSTRU DL and Hand-Calculated Stress Results.....	58

6 CONCLUSIONS.....	83
REFERENCES.....	85
APPENDICES	
A. Hand-Calculations.....	A-1
B. Torsional Analysis Case Charts.....	B-1
C. "TORSION" Program Input Files and Output Printouts....	C-1
D. GTSTRU DL Input/Output Printouts.....	D-1

Chapter One

INTRODUCTION

1.1 Purpose and Objectives

The purpose of this report is to validate a FORTRAN based computer program that analyzes warping and torsion in open steel members. The objective is to verify the program "TORSION" by comparing the program's output with hand-calculations that were derived using an acceptable and proven method of torsional and warping stress analysis. The primary requirement to complete the hand-calculations was to determine the torsional rotational angle, θ , and its derivatives, θ' , θ'' , and θ''' . These values were determined by using the Torsional Analysis Case Charts developed by Bethlehem Steel.

1.2 Scope

In order to validate the torsional and warping stress analysis program, "TORSION", test problems were used that contained the same parameter limits that "TORSION" had. These limits included the types of open steel members, the types of torsional and plane bending loads applied to the member, and the end conditions of the member. "TORSION" analyzed three types of open steel members: (1) wide flange sections, (2) channels and (3) single angles. The end condition parameter included any combination of fixed, pinned or free end conditions. The "TORSION" member load parameter included both uniformly distributed and concentrated plane bending and torsional loads. The Bethlehem Steel Torsional Analysis Case Charts also included the member load parameter of a linearly varying distributed torque, which was not a load parameter of "TORSION".

1.3 Background

Open steel members are subjected to plane bending stresses, torsional and warping stresses or a combination of both. Under plane bending, a member's cross section is subjected to (1) longitudinal/normal bending stress and (2) shear stress.

The normal bending stress (σ_b) is determined by the formula:

$$\sigma_b = M / S \quad (\text{Equ. 1.1})$$

where M = bending moment acting on the member's cross section (k-in.)

S = section modulus of the member (in.³)

The shear stress (τ_b) on the member's cross section is determined by the formula:

$$\tau_b = V Q / I t \quad (\text{Equ. 1.2})$$

where V = shear force acting on the member's cross section (k)

Q = The statical moment about the cross section's neutral axis of the cross-sectional area between the free ends and a plane cutting the cross section at a specified point (in.³)

I = moment of inertia of the member (in.⁴)

t = thickness of the member's web or flange (in.)

Figure 1 illustrates the plane bending and shear stresses in an open steel cross-section.

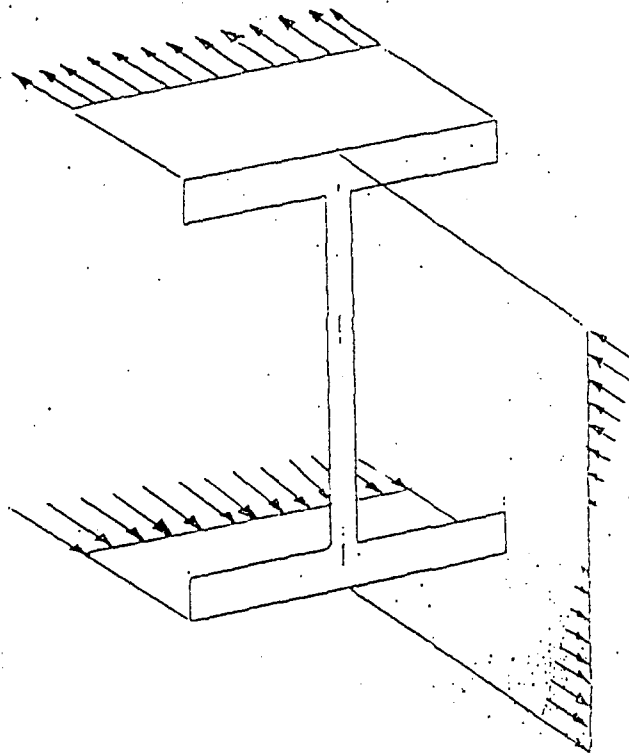

(a) Bending Stresses (σ_b)

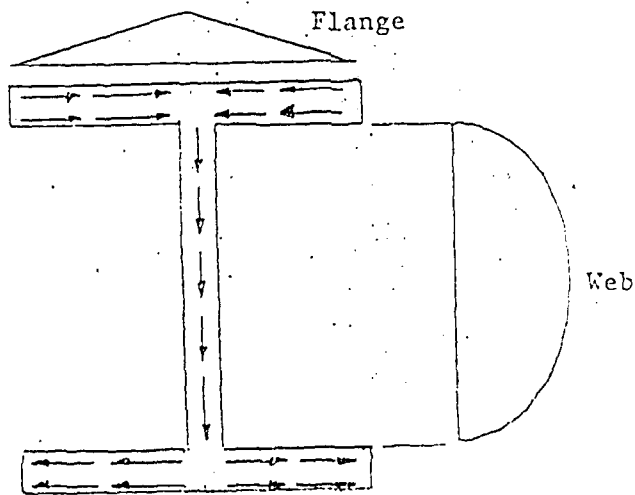

(b) Shear Stresses (τ_b)

Figure 1. PLANE BENDING STRESSES

Open steel members that are under torsional loadings are subjected to (1) pure torsional shear stresses, (2) warping normal stresses and (3) warping shear stresses. The torsional moment of resistance of an open steel member is a combination of St. Venant's torsional moment for an unrestrained cross-section and warping torsional moment of a restrained cross-section.

The pure torsional shear stress (τ_t) is determined by the formula:

$$\tau_t = G t \phi' \quad (\text{Equ. 1.3})$$

where G = shear modulus of the member (ksi)

t = thickness of the member's flange or web (in.)

ϕ' = first derivative of the member's torsional angle
of rotation

The warping normal stress (σ_w) is determined by the formula:

$$\sigma_w = E W_{ns} \phi'' \quad (\text{Equ. 1.4})$$

where E = modulus of elasticity of member (ksi)

W_{ns} = normalized warping function on the member's
cross section (in.²)

ϕ'' = second derivative of the member's torsional
angle of rotation

The warping shear stress (τ_{ws}) is determined by the formula:

$$\tau_{ws} = (-E S_{ws} \phi''') / t \quad (\text{Equ. 1.5})$$

where E = modulus of elasticity of member (ksi)

S_{ws} = warping statical moment on the member's
cross section (in.⁴)

t = thickness of member's flange or web

ϕ''' = third derivative of member's torsional
angle of rotation

Figure 2 illustrates the torsional and warping stresses in an open steel member cross-section.

The end conditions used in the torsional and warping shear analysis include fixed, pinned and free end conditions. In the fixed end condition, all rotation and warping of the member's flanges or web is prohibited, and is similar to the fixed end condition used in plane bending. In the pinned end condition, the member's end is allowed to freely warp. However, unlike the pinned end condition used in plane bending, the torsional pinned end condition does not allow the member to rotate. In the free end condition, the member's end is allowed to rotate and warp freely.

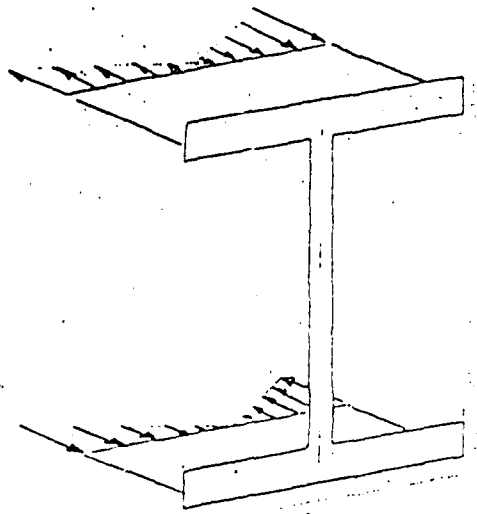

(a) Warping Normal Stress (σ_w)

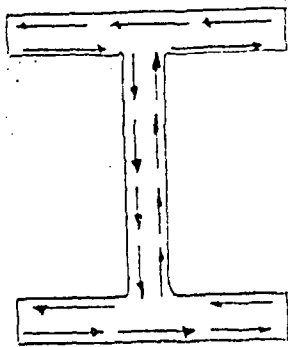

(b) Torsional Shear Stress (τ_t)

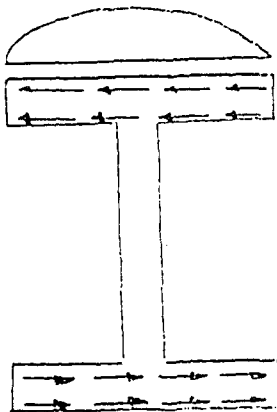

(c) Warping Shear Stress (τ_w)

Figure 2. TORSIONAL AND WARPING STRESSES

Chapter Two

DEVELOPMENT OF HAND-CALCULATED TEST PROBLEMS

2.1 General

Twelve test problems were used to validate the "TORSIGN" program. These twelve problems were analyzed for plane bending stresses as well as the torsional and warping stresses. Hand-calculations were performed by first determining the values of the rotation angles and their derivatives through the Bethlehem Steel Torsional Analysis Case Charts. After these values were determined, the various stresses were calculated using Equations 1.1 through 1.5.

The twelve test problems used were as follows:

<u>Problem No.</u>	<u>Beam Selected</u>	<u>End Conditions</u>
1	W14x109	Fixed-Free
2	W14x159	Pinned-Fixed
3	W12x79	Pinned-Pinned
4	W14x90	Fixed-Fixed
5	W8x15	Fixed-Free
6	W10x49	Fixed-Free
7	W6x15	Fixed-Free
8	W8x67	Fixed-Free
9	C10x20	Fixed-Free
10	C12x30	Fixed-Free
11	C5x9	Fixed-Free
12	MC18x42	Fixed-Free

Although "TORSION" performed torsional shear analysis on single angle members, these member types could not be properly validated by hand due to limitations in using the Torsional Analysis Case Charts and in the "TORSION" program output printout for single angle member cases. These limitations are further discussed in later chapters.

Each test problem consisted of either a wide flange member or channel member under various plane bending and/or torsional loads. The various bending and torsional stresses were calculated at several key locations along the beam's length, as well as at various key points within the beam's cross-section.

For each specified location along the beam's length, there were six items that were calculated for each test problem: (1) values of θ , θ' , θ'' and θ''' , (2) plane bending stress (σ_b), (3) web and flange shear stresses (τ_{bw} and τ_{bf}), (4) torsional shear stresses at the web and flange (τ_{tw} and τ_{tf}), (5) warping normal stresses at the flange tips (σ_w), and (6) warping shear stresses at the flange centers (τ_{ws}).

Hand-calculations for each problem are shown in Appendix A.

2.2 Torsional Analysis Case Charts

The Torsional Analysis Case Charts developed by Bethlehem Steel were used to determine the values of θ , θ' , θ'' and θ''' for each problem. Although the charts consist of twenty-six various cases with various torsional load types and end conditions, thirteen of the charts were used for the twelve test problems based on the selected loadings and end conditions. The charts are based on four parameters: (1) type of torsional load, (2) end conditions, (3) location along the member's length (shown in the charts as Fraction of Span Length Z/L), and (4) the ratio of

the member's overall length (L) to the member's torsional constant ($a = \sqrt{EC_w/GJ}$). This L/a ratio is the actual curved lines on each chart.

For each chart, the x-axis represents the Fraction of Span Length (Z/L) and the y-axis represents the torsional function value that will be used to determine the actual values of ϕ , ϕ' , ϕ'' and ϕ''' . The L/a ratio is one of the limiting factors when using the charts. Depending on the particular chart being used, the L/a ratio chart curves are shown for L/A values of 0.5, 1.0, 2.0, 3.0, 4.0 and 6.0. Interpolation can be performed for an L/a value that is between two of the curves. However, there can be no accurate interpolation for an L/a value greater than 6.0 since this is the last curve depicted on the charts. Since "L" and "a" are both dimensions and properties of the beam used, member length and type are governing factors in selecting a beam whose L/a ratio is 6.0 or less.

Due to the L/a ratio limitation of the charts, few single angle members could be used. Because the torsional constant "a" is so small for single angles, these members could only have a length of a few inches in order to remain within the L/a ratio curves on the charts.

The actual Case Charts used for the test problems are shown in Appendix B. Listed on each Case Chart is the specific test problem(s) for which it was used.

2.3 Determination of Plane Bending, Torsional and Warping Stresses

The determination of plane bending stresses on the member is made by analyzing the plane bending and shear forces acting on the member. Shear and moment diagrams are established illustrating the magnitude of these forces at various locations along the beam's length. Equations 1.1 and 1.2 are then used to calculate the plane bending stresses and the shear

stresses in the member's web and flanges. These plane bending and shear stresses were calculated at the points on the extreme fibers of the flange tips and flange/web connection. These calculation points are shown as points 0 and 2 on the wide-flange cross-section, and points 0, 1 and 2 on the channel cross-sections.

The determination of torsional and warping stresses on the member is made by analyzing each torsional load that is applied to the member. A separate and specific Torsional Analysis Case Chart is selected for each individual torsional load to determine the values of ϕ , ϕ' , ϕ'' and ϕ''' . After these values are calculated for each torsional load, they are summed up to determine the overall values at each specified location along the member's length. These summed values of ϕ , ϕ' , ϕ'' and ϕ''' are then used in Equations 1.3, 1.4 and 1.5 to calculate the torsional and warping stresses in the member's flange and/or web. However, the torsional and warping stresses were calculated at the mid-thickness of the flange tips and flange/web connection. Unlike the plane bending stresses that were calculated at the extreme fibers of the member's cross-section, these torsional and warping stresses were calculated at point differed by one-half the flange thickness. Figure 3 illustrates this offset difference.

In summing up the plane bending stresses with the torsional and warping stresses, this difference between the points of calculation were not taken into account. The differences in the calculation points from the cross-section's neutral axis caused by the one-half flange thickness offset was approximately 3.9% to 10.0% for the twelve test problem beams. By not including this offset in the stress calculation summations, some percent differences resulted between the hand-calculated results and the "TORSION" program results.

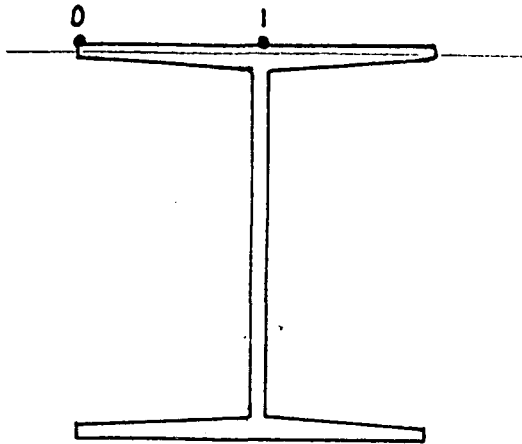

- a. Points of calculation on flange for Plane Bending stresses. (extreme fibers of flange)

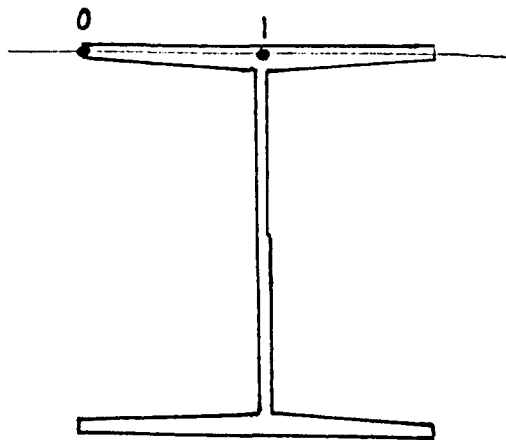

- b. Points of calculation on flange for Torsional and Warping stresses. (mid-thickness of flange)

Figure 3. OFFSET DIFFERENCES FOR POINTS OF STRESS CALCULATION

The points of calculation for the stresses in the member's web, shown as point 3 on the cross-section, were the same for both plane bending and torsional and warping stresses. Therefore, there were no additional differences between the hand-calculations and the program for point 3.

The twelve test problems shown in Appendix A illustrate the unique aspects of each case, and show how the Torsional Analysis Case Charts are used in combination with one another to determine the appropriate torsional values under various torsional load conditions.

Chapter Three

"TORSION" PROGRAM FOR STRESS ANALYSIS

3.1 General

The torsional stress analysis program "TORSION" required that input files for each test problem to be run be established indicating the various parameters, properties, dimensions, end conditions, locations along the member length to be examined, load types and load magnitudes applied to the selected member.

The program also had three general requirements/assumptions that the user needed to be aware of: (1) all units are in kips and inches, (2) there is a positive upward and to the left sign convention and (3) all loads are applied at the shear center of each member, and therefore, a non-torsional load cannot induce torsional stresses. Due to the third requirement/assumption, the program "TORSION" does not account for the additional torsional load on a channel's cross-section caused by the eccentricity between the point of load application on the cross-section's centroid and the shear center.

The boundary conditions for "TORSION" consisted of fixed, pinned or free end conditions or any combination thereof. Similar to the Torsional Analysis Case Charts, the fixed condition prevented both rotation and warping of the member's end and the pinned end condition prevented end rotation but allowed for warping.

Prior to using the "TORSION" program, the source program file had to be re-compiled on an IBM computer using a FORTRAN compiler that different than that used by "TORSION's" original author.

3.2 Input and Output Files

An input file for "TORSION" was established for each of the twelve test problems. "TORSION" output files listed the various parameters, forces, properties and dimensions for the beam selected, as well as the sections along the member's length that were to be analyzed.

For each torsional loading, the values of θ , θ' , θ'' and θ''' were calculated and listed. Normal and torsional stresses at various points of the member's cross-section were listed for all plane bending and torsional loadings as well as the combined bending/torsional loadings. Although the stresses were calculated with the summation of all torsional loadings, the values of θ , θ' , θ'' and θ''' were only listed for each individual torsional loading, and had to be summed up by hand.

A complete list of each input file and "TORSION" output printout for the twelve test problems are shown in Appendix C.

Chapter Four

COMPARISON OF "TORSION" PROGRAM AND HAND-CALCULATED STRESS RESULTS

4.1 General

Comparison tables of the various results acquired through the "TORSION" program and hand-calculations were established to determine the percent differences between the two analysis methods. Percent differences in both the plane bending stresses, torsional and warping stresses were calculated and tabulated for each test problem. Since the torsional and warping stresses are directly correlated to ϕ' , ϕ'' and ϕ''' (Equations 1.3, 1.4 and 1.5), comparison tables of the torsional angle of rotation and its derivatives are also shown.

4.2 "TORSION"/Hand-Calculation ϕ , ϕ' , ϕ'' , ϕ''' Comparison Tables

Tables 4.1 through 4.8 illustrate the Phi angle/derivatives comparison for wide-flange sections. The percent differences calculated range from 0% to 24.56%. Although most differences are within 15%, there are random differences that are higher.

Tables 4.9a through 4.12b illustrate the Phi angle/derivatives comparison for channel sections. These percent differences range from 0% to 52.96%. Although most differences are within 15%, there are random differences that are higher.

Since the values of ϕ , ϕ' , ϕ'' and ϕ''' were derived through interpolation of the Torsional Analysis Case Charts, errors in interpolating the exact value from the L/a ratio curve did contribute to the percent differences. In addition, Tables 4.9a, 4.9b, 4.12a and 4.12b illustrate the significant percent differences in ϕ , ϕ' , ϕ'' and ϕ''' that

PHI ANGLE AND DERIVATIVES
COMPARISON TABLE

Problem No.: 1
Beam Selected: W14x109
End Conditions: Fixed-Free
Length (inches): 300

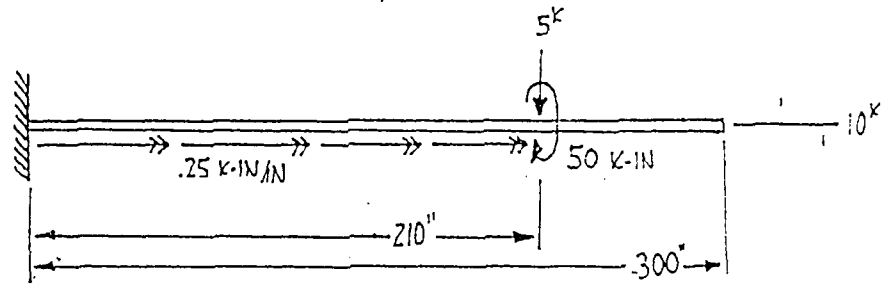

	"Torsion"	"Hand-Calc."	% Diff.
At Support (0 in):			
Phi	0	0	0%
Phi''	1.15753x10 ⁻⁵	1.14363x10 ⁻⁵	1.20%
Phi'	0	0	0%
Phi'''	-1.74761x10 ⁻⁷	-1.75000x10 ⁻⁷	0.14%
At .7L (210 in):			
Phi	.090238	.0912537	1.11%
Phi''	-3.45695x10 ⁻⁶	-3.41456x10 ⁻⁶	1.23%
Phi'	3.79325x10 ⁻⁴	.0003906	2.89%
Phi'''	-3.36750x10 ⁻⁸	-3.12564x10 ⁻⁸	7.19%
At Free End (300 in):			
Phi	.115666	.1163885	0.62%
Phi''	4.04x10 ⁻¹¹ = "0"	0	0%
Phi'	.00023662	.000202459	14.44%
Phi'''	3.21707x10 ⁻⁸	2.7502x10 ⁻⁸	14.51%

Table 4.1:- PHI ANGLE/DERIVATIVES, PROBLEM 1

PHI ANGLE AND DERIVATIVES
COMPARISON TABLE

Problem No.: 2
Beam Selected: W14x159
End Conditions: Pinned-Fixed
Length (inches): 432

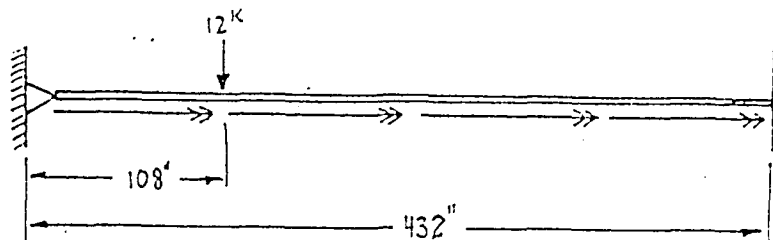

	"Torsion"	"Hand-Calc."	% Diff.
At Pinned Support (0 in):			
Phi	0	0	0%
Phi''	$4.2778 \times 10^{-13} = "0"$	0	0%
Phi'	$.13633 \times 10^{-3}$	$.123196 \times 10^{-3}$	9.63%
Phi'''	$-.16323 \times 10^{-7}$	$-.165058 \times 10^{-7}$	1.11%
At .25L (108 in):			
Phi	.012334	.010649	13.66%
Phi''	$-.86267 \times 10^{-6}$	$-.84551 \times 10^{-6}$	1.98%
Phi'	$.77173 \times 10^{-4}$	6.92979×10^{-6}	10.20%
Phi'''	$-.28600 \times 10^{-8}$	-3.30116×10^{-9}	13.36%
At Fixed Support (432 in):			
Phi	$.72407 \times 10^{-7} = "0"$	0	0%
Phi''	$.29064 \times 10^{-5}$	2.67744×10^{-6}	7.88%
Phi'	$.10643 \times 10^{-11} = "0"$	0	0%
Phi'''	$.59098 \times 10^{-7}$	5.61197×10^{-8}	5.04%

Table 4.2 - PHI ANGLE/DERIVATIVES, PROBLEM 2

**PHI ANGLE AND DERIVATIVES
COMPARISON TABLE**

Problem No.: 3
Beam Selected: W12x79
End Conditions: Pinned-Pinned
Length (inches): 360

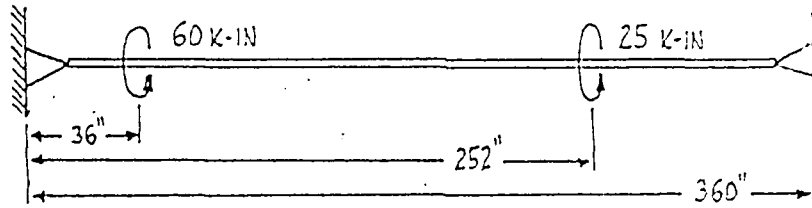

	"Torsion"	"Hand-Calc."	% Diff.
At Left Support (0 in):			
Phi	0	0	0%
Phi''	0	0	0%
Phi'	5.78920x10-4	5.61524x10-4	3.00%
Phi'''	-1.72400x10-7	-1.75724x10-7	1.89%
At .1L (36 in):			
Phi	.019483	.018792	3.55%
Phi''	-6.48172x10-6	-6.16842x10-6	4.83%
Phi'	4.64730x10-4	4.49917x10-4	3.19%
Phi'''	-1.95537x10-7	-1.98307x10-7	1.39%
At .7L (252 in):			
Phi	.038165	.037123	2.73%
Phi''	-4.2233x10-6	-4.18394x10-6	0.93%
Phi'	-2.2093x10-4	-2.16240x10-4	2.12%
Phi'''	-5.18222x10-8	-4.9636x10-8	4.22%
At Right Support (360 in):			
Phi	8.6327x10-8 = "0"	0	0%
Phi''	1.9459x10-11 = "0"	0	0%
Phi'	-4.16280x10-4	-3.98763x10-4	3.37%
Phi'''	2.76902x10-8	2.98754x10-8	9.32%

Table 4.3 - PHI ANGLE/DERIVATIVES, PROBLEM 3

PHI ANGLE AND DERIVATIVES
COMPARISON TABLE

Problem No.: 4
Beam Selected: W14x90
End Conditions: Fixed-Fixed
Length (inches): 480

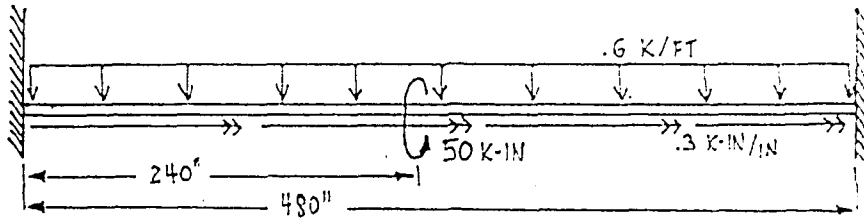

	"Torsion"	"Hand-Calc."	% Diff.
At Left Support (0 in):			
Phi	0	0	0%
Phi''	1.38387x10 ⁻⁵	1.35564x10 ⁻⁵	2.04%
Phi'	0	0	0%
Phi'''	-2.08483x10 ⁻⁷	-2.09115x10 ⁻⁷	0.30%
At .5L (240 in):			
Phi	.096856	.097553	0.71%
Phi''	-8.1611x10 ⁻⁶	-8.06937x10 ⁻⁶	1.12%
Phi'	2.76211x10 ⁻⁹ = "0"	0	0%
Phi'''	-5.37320x10 ⁻⁸	-5.38956x10 ⁻⁸	0.30%
At Right Support (480 in):			
Phi	1.8102x10 ⁻⁶ = "0"	0	0%
Phi''	1.38388x10 ⁻⁵	1.35564x10 ⁻⁵	2.04%
Phi'	-2.2859x10 ⁻⁹ = "0"	0	0%
Phi'''	2.08483x10 ⁻⁷	2.091146x10 ⁻⁷	0.30%

Table 4.4 - PHI ANGLE/DERIVATIVES, PROBLEM 4

PHI ANGLE AND DERIVATIVES
COMPARISON TABLE

Problem No.: 5
Beam Selected: W8x15
End Conditions: Fixed-Free
Length (inches): 60

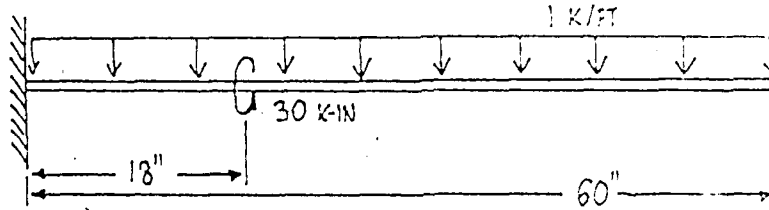

	"Torsion"	"Hand-Calc."	% Diff.
At Support (0 in):			
Phi	0	0	0%
Phi''	.27899x10 ⁻³	.00027499	1.08%
Phi'	0	0	0%
Phi'''	-.20042x10 ⁻⁴	-.00001998	0.31%
At .3L (18 in):			
Phi	.026647	.030922	13.83%
Phi''	-.54646x10 ⁻⁴	-.00005465	3.19%
Phi'	.19654x10 ⁻²	.0019695	0.21%
Phi'''	-.18042x10 ⁻⁴	-.00001798	0.34%
At Free End (60 in):			
Phi	.080349	.080397	0.06%
Phi''	.63497x10 ⁻¹¹ = "0"	0	0%
Phi'	.96339x10 ⁻³	.0007878	18.23%
Phi'''	.98034x10 ⁻⁶	7.99x10 ⁻⁷	18.50%

Table 4.5 - PHI ANGLE/DERIVATIVES, PROBLEM 5

PHI ANGLE AND DERIVATIVES
COMPARISON TABLE

Problem No.: 6
Beam Selected: W10x49
End Conditions: Fixed-Free
Length (inches): 192

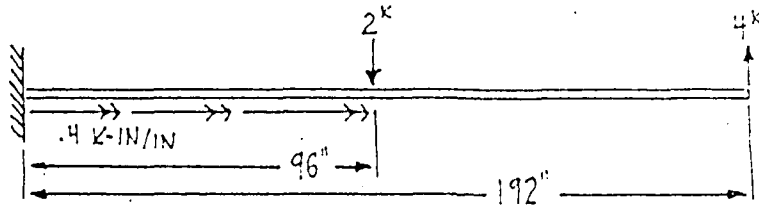

	"Torsion"	"Hand-Calc."	% Diff.
At Support (0 in):			
Phi	0	0	0%
Phi''	.19602x10-4	.18693x10-4	4.94%
Phi'	0	0	0%
Phi'''	-.63952x10-6	-6.22110x10-7	2.72%
At .5L (96 in):			
Phi	.029039	.02620	9.78%
Phi''	-.36197x10-5	-3.6230x10-6	0.09%
Phi'	.24734x10-3	.0002422	2.08%
Phi'''	.63667x10-7	6.22110x10-8	2.29%
At Free End (192 in):			
Phi	.043101	.04030	6.50%
Phi''	-.26550x10-11 = "0"	0	0%
Phi'	.10137x10-3	.0001211	16.29%
Phi'''	.26093x10-7	2.0737x10-8	20.53%

Table 4.6 -PHI ANGLE/DERIVATIVES, PROBLEM 6

PHI ANGLE AND DERIVATIVES
COMPARISON TABLE

Problem No.: 7
Beam Selected: W6x15
End Conditions: Fixed-Free
Length (inches): 42

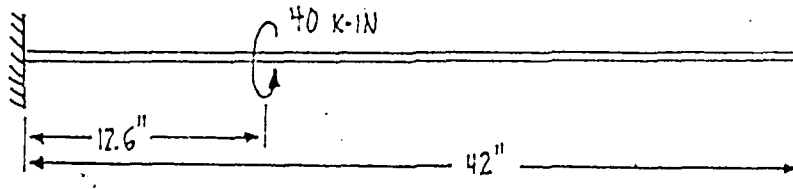

	"Torsion"	"Hand-Calc."	% Diff.
At Support (0 in):			
Phi	0	0	0%
Phi''	.20651x10-3	.00021008	1.70%
Phi'	0	0	0%
Phi'''	-.18043x10-4	-.00001828	1.30%
At .3L (12.6 in):			
Phi	.010563	.007893	24.56%
Phi''	-.15550x10-4	-.00001616	3.77%
Phi'	.11951x10-2	.00142857	16.34%
Phi'''	-.17439x10-4	-.00001773	1.64%
At Free End (42 in):			
Phi	.041242	.047357	12.91%
Phi''	.23221x10-12 = "0"	0	0%
Phi'	.07444x10-3	.00107143	9.05%
Phi'''	.49229x10-6	5.4843x10-7	10.24%

Table 4.7 - PHI ANGLE/DERIVATIVES, PROBLEM 7

PHI ANGLE AND DERIVATIVES
COMPARISON TABLE

Problem No.: 8
Beam Selected: W8x67
End Conditions: Fixed-Free
Length (inches): 108

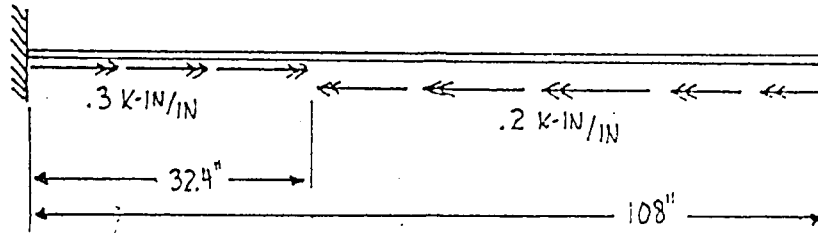

	"Torsion"	"Hand-Calc."	% Diff.
At Support (0 in):			
Phi	0	0	0%
Phi''	-6.2595×10^{-6}	-6.188×10^{-6}	1.14%
Phi'	0	0	0%
Phi'''	1.2945×10^{-7}	1.30×10^{-7}	0.38%
At .3L (31.4 in):			
Phi	-2.55981×10^{-3}	-2.6162×10^{-3}	2.16%
Phi''	-1.76108×10^{-6}	-1.8566×10^{-6}	5.14%
Phi'	-1.34279×10^{-4}	-.0001371	2.06%
Phi'''	1.80392×10^{-7}	1.69×10^{-7}	6.32%
At Free End (108 in):			
Phi	-1.13664×10^{-2}	-.011642	2.37%
Phi''	$-1.48674 \times 10^{-10} = "0"$	0	0%
Phi'	-7.892×10^{-5}	-.00008175	3.46%
Phi'''	-1.07003×10^{-7}	-1.04×10^{-8}	2.81%

Table 4.8 - PHI /ANGLE /DERIVATIVES, PROBLEM 8

PHI ANGLE AND DERIVATIVES
COMPARISON TABLE

Problem No.: 9a
Beam Selected: C10x20
End Conditions: Fixed-Free
Length (inches): 60

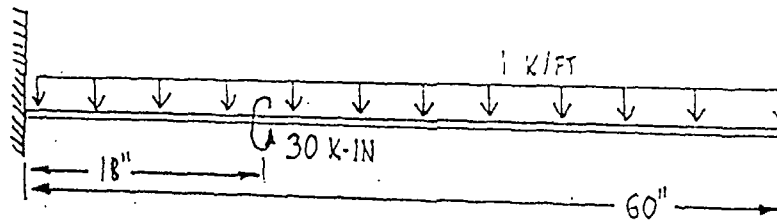

* HAND CALCULATION VALUES INCLUDE THE TORSIONAL FORCES DUE TO ECCENTRIC LOADING OF THE UNIFORM DISTRIBUTED LOAD THROUGH THE CHANNEL'S SHEAR CENTER

	"Torsion"	"Hand-Calc."	% Diff.
At Support (0 in):			
Phi	0	0	0%
Phi''	.21630x10 ⁻³	.0002643	18.16%
Phi'	0	0	0%
Phi'''	-.18174x10 ⁻⁴	-.00002203	17.50%
At .3L (18 in):			
Phi	.019083	.0246337	22.53%
Phi''	-.62927x10 ⁻⁴	-.00005438	13.58%
Phi'	.12938x10 ⁻²	.001773	27.03%
Phi'''	-.14926x10 ⁻⁴	-.00001636	8.74%
At Free End (60 in):			
Phi	.044149	.066842	33.95%
Phi''	-.59204x10 ⁻¹⁰ = "0"	0	0%
Phi'	.31087x10 ⁻²	.0006358	51.11%
Phi'''	.78042x10 ⁻⁶	.000001605	51.38%

Table 4.9a - PHI ANGLE/DERIVATIVES, PROBLEM 9a

PHI ANGLE AND DERIVATIVES
COMPARISON TABLE

Problem No.: 9b
Beam Selected: C10x20
End Conditions: Fixed-Free
Length (inches): 60

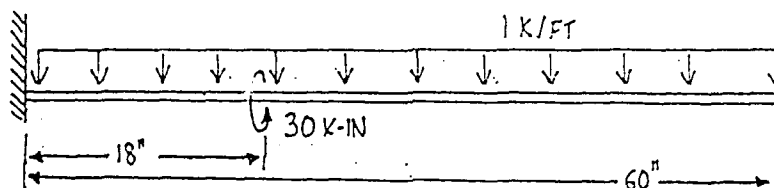

* HAND CALCULATION VALUES DO NOT INCLUDE THE TORSIONAL FORCES DUE TO ECCENTRIC LOADING OF THE UNIFORM DISTRIBUTED LOAD THROUGH THE CHANNEL'S SHEAR CENTER

	"Torsion"	"Hand-Calc."	% Diff.
At Support (0 in):			
Phi	0	0	0%
Phi''	.21630x10 ⁻³	.0002146	0.79%
Phi'	0	0	0%
Phi'''	-.18174x10 ⁻⁴	-.00001828	0.58%
At .3L (18 in):			
Phi	.019083	.018728	1.86%
Phi''	-.62927x10 ⁻⁴	-.00006184	1.73%
Phi'	.12938x10 ⁻²	.0013031	0.71%
Phi'''	-.14926x10 ⁻⁴	-.00001499	0.40%
At Free End (60 in):			
Phi	.044149	.043219	2.11%
Phi''	-.59204x10 ⁻¹⁰ = "0"	0	0%
Phi'	.31087x10 ⁻²	.0002896	6.84%
Phi'''	.78042x10 ⁻⁶	7.3126x10 ⁻⁷	6.30%

Table 4.9b - PHI ANGLE/DERIVATIVES, PROBLEM 9b

PHI ANGLE AND DERIVATIVES
COMPARISON TABLE

Problem No.: 10
Beam Selected: C12x30
End Conditions: Fixed-Free
Length (inches): 108

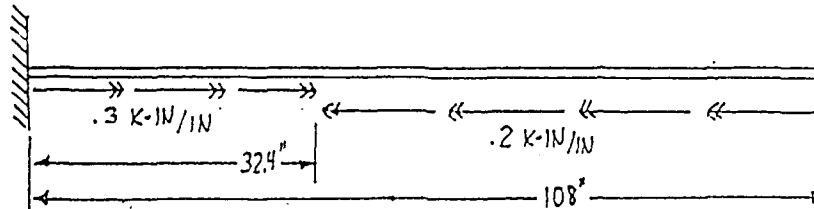

	"Torsion"	"Hand-Calc."	% Diff.
At Support (0 in):			
Phi	0	0	0%
Phi''	-4.6154×10^{-5}	$-.4542 \times 10^{-4}$	1.59%
Phi'	0	0	0%
Phi'''	1.2313×10^{-6}	1.212×10^{-6}	1.57%
At .3L (32.4 in):			
Phi	-1.8079×10^{-2}	$-.017098$	5.30%
Phi''	-1.02406×10^{-5}	-1.3423×10^{-5}	23.71%
Phi'	-9.2765×10^{-4}	-9.014×10^{-4}	2.79%
Phi'''	1.39828×10^{-6}	1.35621×10^{-6}	4.21%
At Free End (108 in):			
Phi	-7.24163×10^{-2}	$-.070244$	3.00%
Phi''	$-8.12819 \times 10^{-9} = "0"$	0	0%
Phi'	-4.02456×10^{-4}	$-.0004177$	3.65%
Phi'''	-8.88997×10^{-7}	-8.7229×10^{-7}	1.98%

Table 4.10 - PHI ANGLE/DERIVATIVES, PROBLEM 10

PHI ANGLE AND DERIVATIVES
COMPARISON TABLE

Problem No.: 11
Beam Selected: C5x9
End Conditions: Fixed-Free
Length (inches): 42

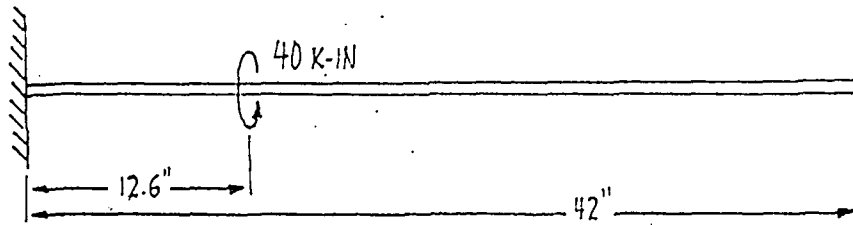

	"Torsion"	"Hand-Calc."	% Diff.
At Support (0 in):			
Phi	0	0	0%
Phi''	.30579x10-2	.002950	3.53%
Phi'	0	0	0%
Phi'''	-.47020x10-3	-.000472	0.38%
At .3L (12.6 in):			
Phi	.11685	.114633	1.90%
Phi''	-.11897x10-2	-.001141	4.09%
Phi'	.99488x10-2	.009830	1.19%
Phi'''	-.32743x10-3	-.000331	1.08%
At Free End (42 in):			
Phi	.19976	.196514	1.62%
Phi''	.189x10-8 = "0"	0	0%
Phi'	.58739x10-3	.000655	10.32%
Phi'''	.84293x10-5	.00000944	10.71%

Table 4.11 -PHI ANGLE/DERIVATIVES, PROBLEM 11

**PHI ANGLE AND DERIVATIVES
COMPARISON TABLE**

Problem No.: 12a
Beam Selected: MC18x42
End Conditions: Fixed-Free
Length (inches): 192

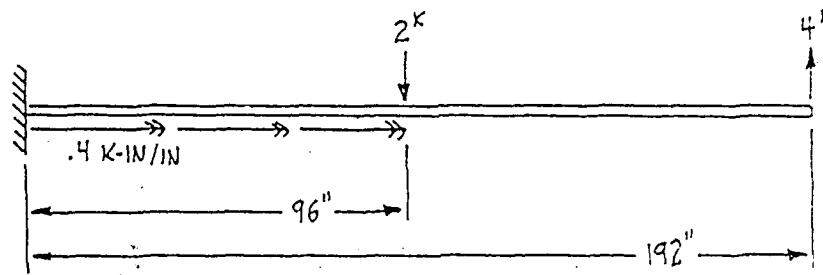

* HAND CALCULATION VALUES INCLUDE THE TORSIONAL FORCES DUE TO ECCENTRIC LOADING OF THE TWO CONCENTRATED LOADS THROUGH THE CHANNEL'S SHEAR CENTER

	"Torsion"	"Hand-Calc."	% Diff.
At Support (0 in):			
Phi	0	0	0%
Phi''	.39802x10-4	4.656x10-5	14.51%
Phi'	0	0	0%
Phi'''	-.15538x10-5	-1.6933x10-6	8.24%
At .5L (96 in):			
Phi	.049015	.06624	26.00%
Phi''	-.74574x10-5	-3.5077x10-6	52.96%
Phi'	.32272x10-3	.0006811	52.62%
Phi'''	.17989x10-6	2.31328x10-7	22.24%
At Free End (192 in):			
Phi	.062393	.12042	48.19%
Phi''	-.25325x10-9 = "0"	0	0%
Phi'	.66205x10-4	.000056361	14.87%
Phi'''	.36904x10-7	1.7916x10-8	51.45%

Table 4.12a - PHI ANGLE/DERIVATIVES, PROBLEM 12a

PHI ANGLE AND DERIVATIVES
COMPARISON TABLE

Problem No.: 12b
Beam Selected: MC18x42
End Conditions: Fixed-Free
Length (inches): 192

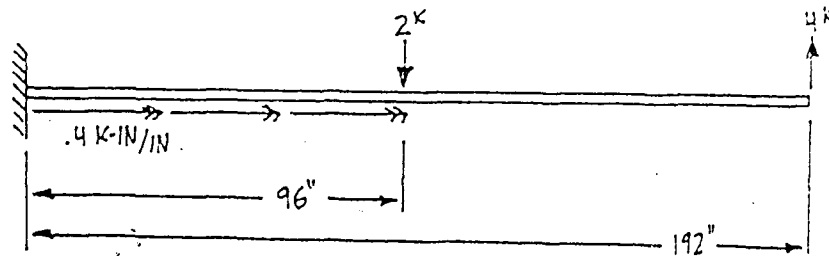

* HAND CALCULATION VALUES DO NOT INCLUDE THE TORSIONAL FORCES DUE TO ECCENTRIC LOADING OF THE TWO CONCENTRATED LOADS THROUGH THE CHANNEL'S SHEAR CENTER

	"Torsion"	"Hand-Calc."	% Diff.
At Support (0 in):			
Phi	0	0	0%
Phi''	.39803x10-4	.39488x10-4	.79%
Phi'	0	0	0%
Phi'''	-.15538x10-5	-.1544x10-5	.63%
At .5L (96 in):			
Phi	.049015	.04884	.36%
Phi''	-.74574x10-5	-7.5494x10-6	1.22%
Phi'	.32272x10-3	3.07060x10-3	1.16%
Phi'''	.17989x10-6	1.7161x10-7	4.60%
At Free End (192 in):			
Phi	.062393	.06234	.08%
Phi''	-.25325x10-9 = "0"	0	0%
Phi'	.66205x10-4	.614x10-4	7.26%
Phi'''	.36904x10-7 = "0"	0	0%

Table 4.12b - PHI ANGLE/DERIVATIVES, PROBLEM 12b

occur when torsional forces due to the eccentric loading through a channel's shear center are included in the calculations.

4.3 "TORSION"/Hand-Calculation Stress Comparison Tables

Tables 4.13 through 4.24b illustrate the normal stresses and torsional stresses calculated determined by the "TORSION" program and hand-calculations, and the percent differences between the two analysis methods.

Percent differences could not be calculated in cases where the stress value derived by hand was 0 ksi and the stress derived by "TORSION" was an actual value. Percent differences for these cases are annotated by a question mark.

Tables 4.13 through 4.24b also illustrate the errors in the "TORSION" stress output. For example, in Test Problem No. 5 (W8x15, Fixed-Free), "TORSION" calculates an increasing bending and shear stress along the member's length from the support to the free end, which cannot be the case for these boundary conditions. Similar situations with plane bending stresses for the fixed-free boundary conditions are apparent in Test Problems No's. 6, 9a, 12a and 12b.

In the other cases, the percent differences are quite small. Comparison of the percent differences of the ϕ' , ϕ'' and ϕ''' at specific length locations and cross-section points with the calculated stress percent differences at the same points and locations show a high degree of similarity. This, of course, would be the case since the stresses calculated with Equations 1.3, 1.4 and 1.5 are directly related to the ϕ' , ϕ'' and ϕ''' values. Therefore, percent differences in these values would be reflected by similar percent differences in the calculated stresses.

"TORSION" AND HAND-CALCULATION RESULTS
COMPARISON TABLE

Problem 1
Beam Selected: W14x109
End Conditions: Fixed-Free

Analyses taken at 3 Locations:

Location 1: 0 inches
Location 2: 210 inches
Location 3: 300 inches

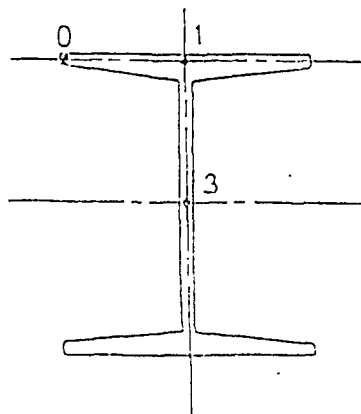
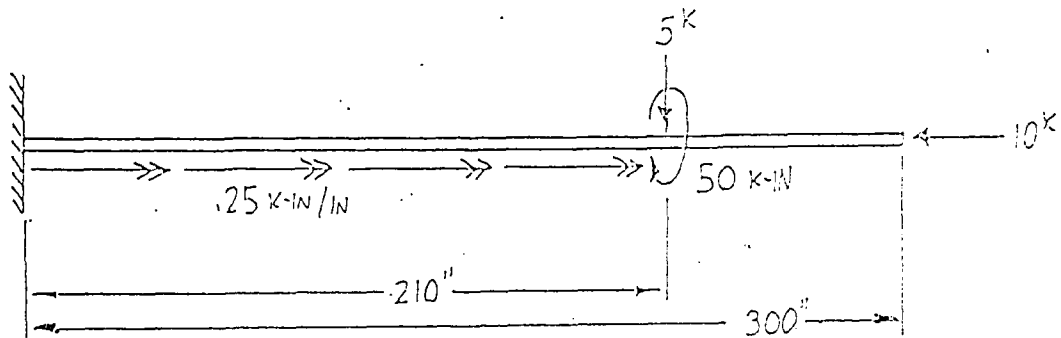

Pl. 0: Flange Tip
Pl. 1: Flange/Web Connection
Pl. 3: Web (at Neutral Axis)

PROBLEM: 1
 BEAM: W14x109
 Fixed-Free
 Length: 300"

	0 in. LOCATION (1)			210 in. LOCATION (2)			300 in. LOCATION (3)			
	"TORSION"	HAND-CALC.	% DIFF	"TORSION"	HAND-CALC.	% DIFF	"TORSION"	HAND-CALC.	% DIFF	
NORMAL STRESS										
TORSIONAL	OPT. 0	16.49744	16.28415	1.29	-4.926913	-4.86199	1.32	-0.00057	0	0
(σ_{ws})	OPT. 1									
ksi	OPT. 3									
BENDING	OPT. 0	-6.391864	-6.0624	4.5	0	0	0	0	0	0
(σ_b)	OPT. 1									
ksi	OPT. 3									
SHEAR STRESS										
TORSIONAL	OPT. 0	0	0	0	3.653625	3.76226	2.89	2.279096	1.95009	14.44
(τ_t)	OPT. 1									
ksi	OPT. 3	0	0	0	2.230411	2.29673	2.89	1.391308	1.19096	14.44
WARPING	OPT. 0	0.509432	0.9088	0.07	0.175244	0.1624	7.53	-0.167413	-0.1428	14.7
(τ_{ws})	OPT. 1									
ksi	OPT. 3									
BENDING	OPT. 0	0.191045	0.1932	1.12	0.191045	0.1932	1.12	0	0	0
(τ_b)	OPT. 1									
ksi	OPT. 3	0.729258	0.7366	1.01	0.729258	0.7366	1.01	0	0	0

Table 4.13 - "TORSION"/HAND-CALC. COMPARISON, PROBLEM 1

"TORSION" AND HAND-CALCULATION RESULTS
COMPARISON TABLE

Problem: 2
Beam Selected: W14x159
End Conditions: Pinned-Fixed

Analyses taken at 3 Locations:

Location 1: 0 inches
Location 2: 108 inches
Location 3: 432 inches

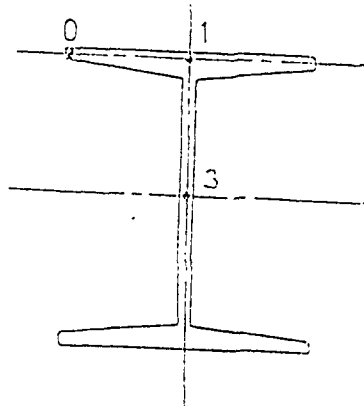
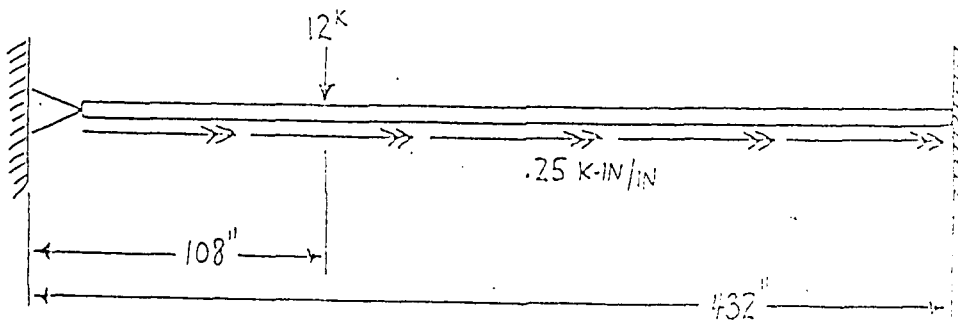

Pl. 0: Flange Tip
Pl. 1: Flange/Web Connection
Pl. 3: Web (at Neutral Axis)

PROBLEM: 2
 BEAM: W14x159
 Pinned-Fixed
 Length: 432"

	0 in.			108 in.			432 in.		
	"TORSION"	HAND-CALC.	% DIFF	"TORSION"	HAND-CALC.	% DIFF	"TORSION"	HAND-CALC.	% DIFF
	LOCATION (1)			LOCATION (2)			LOCATION (3)		
NORMAL STRESS									
TORSIONAL	OPT. 0	0	0	-1.342438	-1.317	1.89	4.522855	4.17	7.81
(σ_{ws})	OPT. 1								
ksi	OPT. 3								
BENDING	OPT. 0	0	0	3.221294	3.227	0.01	2.59811	2.392	0.25
(σ_b)	OPT. 1								
ksi	OPT. 3								
SHEAR STRESS									
TORSIONAL	OPT. 0	1.642	9.63	1.028555	0.924	10.17	0	0	0
(τ_t)	OPT. 1			0.643927	0.578	10.24	0	0	0
ksi	OPT. 3	1.137506	9.63						
WARPING	OPT. 0	0.1	1.15	0.01733	0.02	13.41	-0.35786	-0.339	5.27
(τ_{ws})	OPT. 1								
ksi	OPT. 3	0.093342							
BENDING	OPT. 0	0.206	0.92	0.204099	0.206	0.92	0.112587	0.12	1.19
(τ_b)	OPT. 1			0.764073	0.767	0.38	0.443248	0.446	0.46
ksi	OPT. 3	0.764073	0.38						

Table 4.14 - "TORSION"/HAND-CALC. COMPARISON, PROBLEM 2

"TORSION" AND HAND-CALCULATION RESULTS
COMPARISON TABLE

Problem: 3
Beam Selected: W12x79
End Conditions: Pinned-Pinned

Analyses taken at 4 Locations:

Location 1: 0 inches
Location 2: 36 inches
Location 3: 252 inches
Location 4: 360 inches

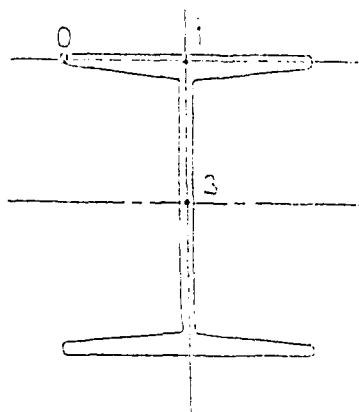
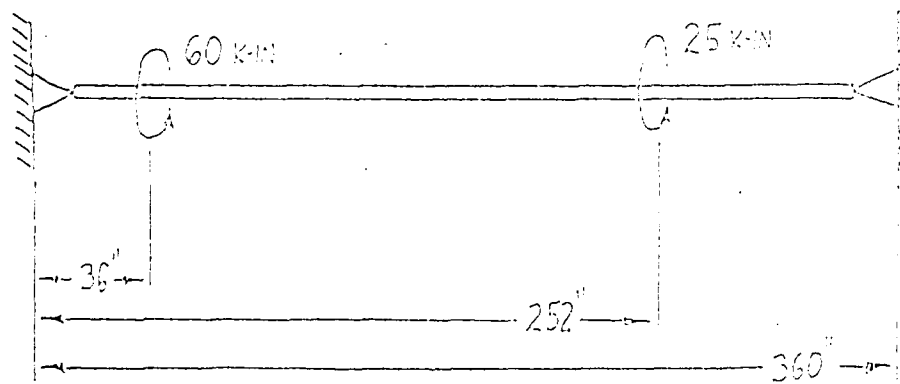

pt. 0: Flange Tip
pt. 1: Flange/Web Connection
pt. 3: Web (at Neutral Axis)

PROBLEM: 3
 BEAM: W12X19
 Pinned-Pinned
 Length: 360"

	0 in. LOCATION (1)			36 in. LOCATION (2)			252 in. LOCATION (3)			360 in. LOCATION (4)		
	"TORSION" HAND-CALC.	% DIFF		"TORSION" HAND-CALC.	% DIFF		"TORSION" HAND-CALC.	% DIFF		"TORSION" HAND-CALC.	% DIFF	
NORMAL STRESS												
TORSIONAL	0	0	0	-6.610305	4.74		-4.307246	0.94		0.00002	0	0
(σ_{xy})												
ksi												
BENDING	0	0	0	0	0	0	0	0	0	0	0	0
(σ_x)												
ksi												
SHEAR STRESS												
TORSIONAL	4.755384	3.05		3.825725	3.29		-1.819743	2.11		-3.337211	-3.28	3.45
(τ_{xy})												
ksi	3.947444	2.97		2.446382	3.12		-1.163006	1.93		-2.172366	-2.11	3.33
WARPING	0.511095	1.84		0.60225	1.43		0.153815	22.52		-0.883439	-0.092	9.31
(τ_{xz})												
ksi												
BENDING	0	0	0	0	0	0	0	0	0	0	0	0
(τ_{yx})												
ksi												

Table 4.15 -- "TORSION"/HAND-CALC. COMPARISON, PROBLEM 3

"TORSION" AND HAND-CALCULATION RESULTS
COMPARISON TABLE

Problem: 4
Beam Selected: W14x90
End Conditions: Fixed-Fixed

Analyses taken at 3 Locations:

Location 1: 0 inches
Location 2: 240 inches
Location 3: 480 inches

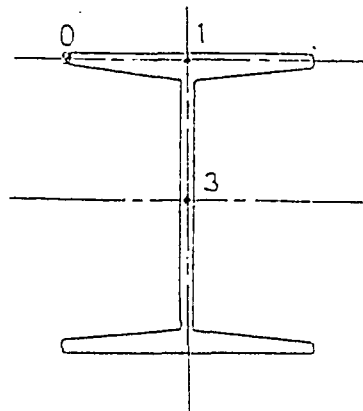
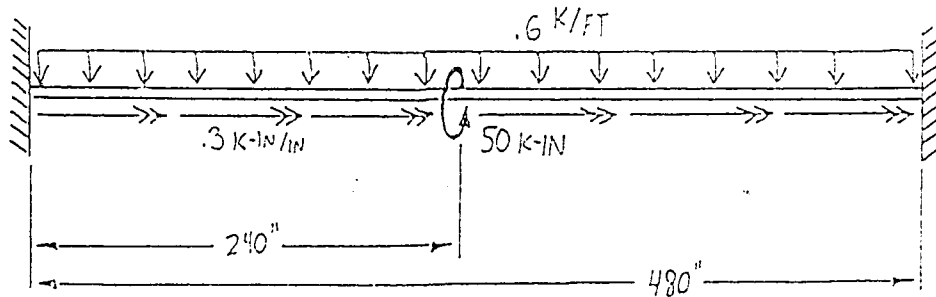

Pt. 0: Flange Tip
Pt. 1: Flange/Web Connection
Pt. 3: Web (at Neutral Axis)

"TORSION" AND HAND-CALCULATION RESULTS
COMPARISON TABLE

Problem: 5
Beam Selected: W8x15
End Conditions: Fixed-Free

Analyses taken at 3 Locations:

Location 1: 0 inches
Location 2: 18 inches
Location 3: 60 inches

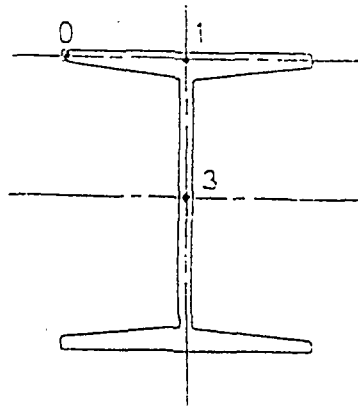
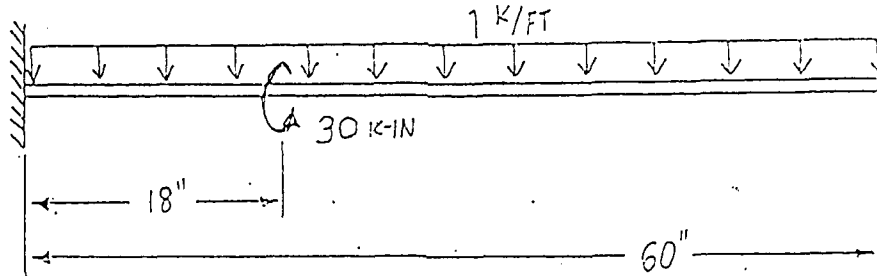

Pt. 0: Flange Tip
Pt. 1: Flange/Web Connection
Pt. 3: Web (at Neutral Axis)

PROBLEM: 5
 BEAM: W8x15
 Fixed-Free
 Length: 60"

0 in.

18 in.

60 in.

	LOCATION (1)			LOCATION (2)			LOCATION (3)			
	"TORSION"	HAND-CALC.	% DIFF	"TORSION"	HAND-CALC.	% DIFF	"TORSION"	HAND-CALC.	% DIFF	
NORMAL STRESS										
TORSIONAL	ØPT. 0	63.30330	62.749	0.88	-12.39934	-12.834	3.39	1.00E-06	0	0
(σ _{ws})	ØPT. 1									
ksi	ØPT. 3									
BENDING	ØPT. 0	-12.71186	-12.712	0	-19.19496	-6.229	67.55	-25.42423	0	?
(σ _b)	ØPT. 1									
ksi	ØPT. 3									
SHEAR STRESS										
TORSIONAL	ØPT. 0	0	0	0	6.933861	6.948	-0.21	3.398853	2.779	18.24
(τ _t)	ØPT. 1									
ksi	ØPT. 3	0	0	0	5.393003	5.404	0.22	2.643353	2.162	18.22
WARPING	ØPT. 0									
(τ _w)	ØPT. 1	4.6364575	4.543	2.16	4.109091	4.089	0.49	-0.223275	-0.192	18.43
ksi	ØPT. 3									
BENDING	ØPT. 0									
(τ _b)	ØPT. 1	0.765292	0.787	2.76	0.535712	0.551	2.77	0.006031	0	0
ksi	ØPT. 3	-2.824257	-2.883	2.04	-1.977042	-2.018	2.03	-0.000113	0	0

"TORSION" AND HAND-CALCULATION RESULTS
COMPARISON TABLE

Problem: 6
Beam Selected: W10x49
End Conditions: Fixed-Free

Analyses taken at 3 Locations:

Location 1: 0 inches
Location 2: 96 inches
Location 3: 192 inches

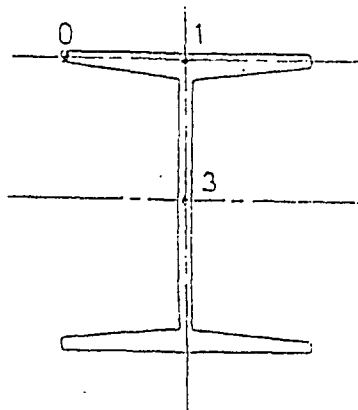
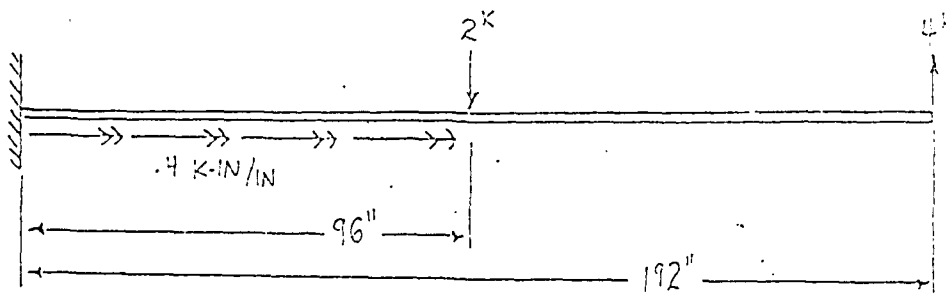

Pt. 0: Flange Tip
Pt. 1: Flange/Web Connection
Pt. 3: Web (at Neutral Axis)

PROBLEM: 6
 BEAM: W10x49
 Fixed-Free
 Length: 192"

0 in.
 LOCATION (1)
 96 in.
 LOCATION (2)
 192 in.
 LOCATION (3)

	LOCATION (1)			LOCATION (2)			LOCATION (3)			
	"TORSION"	HAND-CALC.	% DIFF	"TORSION"	HAND-CALC.	% DIFF	"TORSION"	HAND-CALC.	% DIFF	
NORMAL STRESS										
TORSIONAL	ØPT. 0	13.39747	12.752	4.75	-2.472049	-2.48	0.32	-2.00E-06	0	0
(O _{ys})	ØPT. 1									
ksi	ØPT. 3									
BENDING	ØPT. 0	10.54945	10.549	0	14.06593	7.033	49.99	21.0989	0	?
(O _b)	ØPT. 1									
ksi	ØPT. 3									
SHEAR STRESS										
TORSIONAL	ØPT. 0	0	0	0	1.551303	1.519	2.08	0.635787	0.76	16.34
(T _t)	ØPT. 1	0	0	0	0.941862	0.922	2.11	0.386014	0.461	16.27
ksi	ØPT. 3	0	0	0						
WARPING	ØPT. 0	1.091902	1.06	2.92	-0.108703	-0.106	2.49	-0.044531	-0.035	21.44
(T _{ws})	ØPT. 1									
ksi	ØPT. 3									
BENDING	ØPT. 0	-0.167274	-0.171	2.18	-0.167274	-0.171	2.18	-0.334549	-0.341	1.89
(T _b)	ØPT. 1	0.642566	-0.653	1.59	0.652566	-0.653	1.59	1.265131	-1.306	1.59
ksi	ØPT. 3									

Table 4.18 -- "TORSION"/HAND-CALC. COMPARISON, PROBLEM 6

"TORSION" AND HAND-CALCULATION RESULTS
COMPARISON TABLE

Problem: 7
Beam Selected: W6x15
End Conditions: Fixed-Free

Analyses taken at 3 Locations:

Location 1: 0 inches
Location 2: 12.6 inches
Location 3: 42 inches

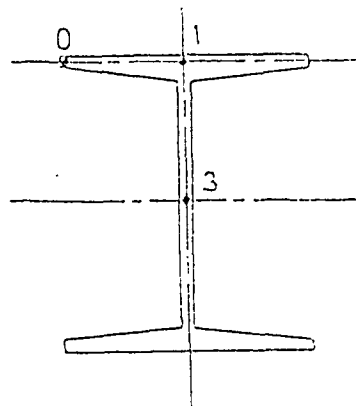
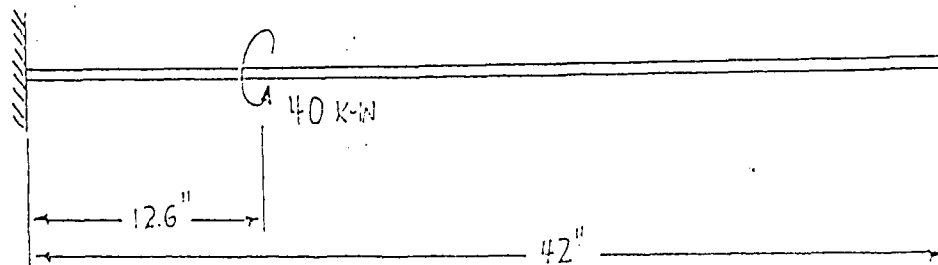

Pt. 0: Flange Tip
Pt. 1: Flange/Web Connection
Pt. 3: Web (at Neutral Axis)

PROBLEM: 7
 BEAM: W6x15
 Fixed-Free
 Length: 42"

0 in. 12.6 in. 42 in.
 LOCATION (1) LOCATION (2) LOCATION (3)

		LOCATION (1)		LOCATION (2)		LOCATION (3)	
		"TORSION"	HAND-CALC.	% DIFF	"TORSION"	HAND-CALC.	% DIFF
		"TORSION"	HAND-CALC.	% DIFF	"TORSION"	HAND-CALC.	% DIFF
NORMAL STRESS							
TORSIONAL	ØPT. 0	51.38705	52.272	1.69	-3.86945	-4.021	3.77
	ØPT. 1						
	ØPT. 3						
		ksi					
BENDING	ØPT. 0	0	0	0	0	0	0
	ØPT. 1						
	ØPT. 3						
		ksi					
SHEAR STRESS							
TORSIONAL	ØPT. 0	0	0	0	3.479986	4.16	16.35
	ØPT. 1						
	ØPT. 3						
		ksi					
WARPING	ØPT. 0	6.723516	6.81	1.27	6.498538	6.605	1.61
	ØPT. 1						
	ØPT. 3						
		ksi					
BENDING	ØPT. 0	0	0	0	0	0	0
	ØPT. 1						
	ØPT. 3						
		ksi					

Table 4.19 - "TORSION"/HAND-CALC. COMPARISON, PROBLEM 7

"TORSION" AND HAND-CALCULATION RESULTS
COMPARISON TABLE

Problem: 8
Beam Selected: W8x67
End Conditions: Fixed-Free

Analyses taken at 3 Locations:

Location 1: 0 inches
Location 2: 32.4 inches
Location 3: 108 inches

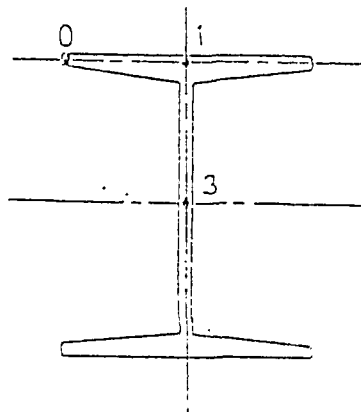
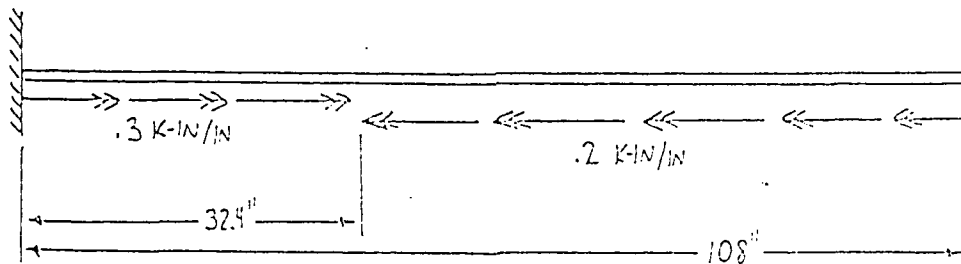

PL. 0: Flange Tip
PL. 1: Flange/Web Connection
PL. 3: Web (at Neutral Axis)

PROBLEM: 8

BEAM: W8x67

Fixed-Free

Length: 108"

0 in.

LOCATION (1)

32.4 in.

LOCATION (2)

108 in.

LOCATION (3)

	"TORSION"	HAND-CALC.	% DIFF	"TORSION"	HAND-CALC.	% DIFF	"TORSION"	HAND-CALC.	% DIFF
NORMAL STRESS									
TORSIONAL	OPT. 0	-3.03032	-2.997	1.09	-0.852609	-0.899	5.16	-7.20E-05	0
(σ ws)	OPT. 1								
ksi	OPT. 3								
BENDING	OPT. 0	0	0	0	0	0	0	0	0
(σ b)	OPT. 1								
ksi	OPT. 3								
SHEAR STRESS									
TORSIONAL	OPT. 0	0	0	0	-1.406199	-1.436	2.08	-0.826452	-0.856
(τ b)	OPT. 1	0	0	0	-0.897254	-0.875	2.03	-0.503826	-0.522
ksi	OPT. 3								
WARPING	OPT. 0	-0.10973	-0.13	0.21	-0.100781	-0.169	6.52	0.107237	0.104
(τ ws)	OPT. 1								
ksi	OPT. 3								
BENDING	OPT. 0	0	0	0	0	0	0	0	0
(τ b)	OPT. 1	0	0	0	0	0	0	0	0
ksi	OPT. 3	0	0	0	0	0	0	0	0

Table 4.20 - "TORSION"/HAND-CALC. COMPARISON, PROBLEM 8

"TORSION" AND HAND-CALCULATION RESULTS
COMPARISON TABLE

Problem: 9
Beam Selected: C10x20
End Conditions: Fixed-Free

Analyses taken at 3 Locations:

Location 1: 0 inches
Location 2: 18 inches
Location 3: 60 inches

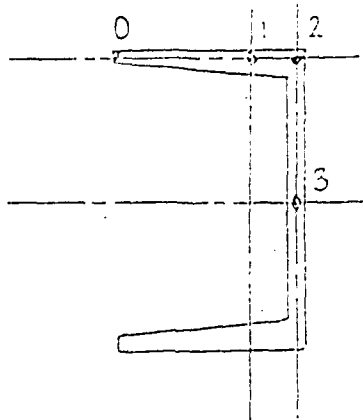
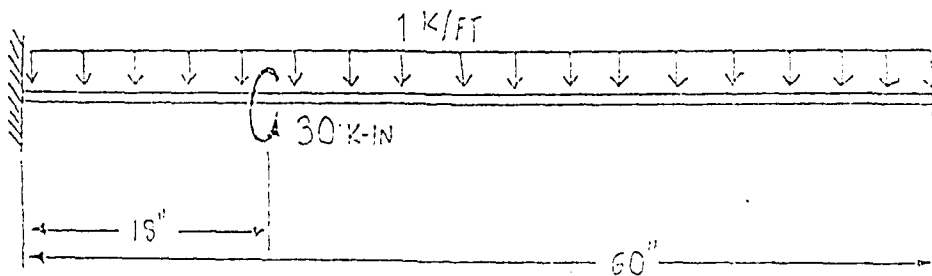

Pt. 0: Flange Tip
Pt. 1: Flange (at Neutral Axis)
Pt. 2: Flange/Web Connection
Pt. 3: Web (at Shear Center)

PROBLEM: 9a (WITH ECCENTRIC TORSION DUE TO UNIFORM LOAD)

BEAM: C10x20

Fixed-Free

Length: 60"

60 in.

18 in.

0 in.

LOCATION (3)

LOCATION (2)

LOCATION (1)

	"TORSION"	HAND-CALC.	% DIFF	"TORSION"	HAND-CALC.	% DIFF	"TORSION"	HAND-CALC.	% DIFF
NORMAL STRESS									
TORSIONAL	OPT. 0	51.701376	63.157	18.14	-15.04127	-12.995	13.61	-1.402-05	0
(σ_{ws})	OPT. 1								
ksi	OPT. 2	24.77346	30.276	18.17	-7.207242	-6.229	13.57	-7.00E-06	0
BENDING	OPT. 0	-9.49367	-9.494	0	-14.33548	-4.652	67.55	-18.98772	0
(σ_b)	OPT. 1	-9.49367	-9.494	0	-14.33548	-4.652	67.55	-18.98772	0
ksi	OPT. 2	-9.49367	-9.494	0	-14.33548	-4.652	67.55	-18.98772	0
SHEAR STRESS									
TORSIONAL	OPT. 1	0	0	0	5.317981	8.658	27.03	1.518031	3.105
(τ_b)	OPT. 2	0	0	0	6.317981	8.658	27.03	1.518031	3.105
ksi	OPT. 3	0	0	0	5.492007	7.526	27.03	1.319572	2.689
HARPING	OPT. 1	3.743765	4.542	17.57	3.074681	3.373	8.84	0.16076	0.331
(τ_{hs})	OPT. 2	2.884202	3.502	17.64	2.368738	2.601	8.93	0.123851	0.255
ksi	OPT. 3	1.653987	2.096	17.32	1.362493	1.491	8.56	0.071239	0.145
BENDING	OPT. 1								
(τ_b)	OPT. 2	0.772605	0.733	5.13	0.540833	0.513	5.15	0.000931	0
ksi	OPT. 3	1.613375	1.634	1.26	1.129382	1.144	1.28	-6.50E-05	0

Table 4.21a -- "TORSION"/HAND-CALC. COMPARISON, PROBLEM 9a

PROBLEM 9b (WITHOUT ECCENTRIC TORSION DUE TO UNIFORM LOAD)

ESAM: C10Y20

Fixed-Free

Length: 50'

50 in.

19 in.

LOCATION (3)

0 in.

LOCATION (2)

LOCATION (1)

	LOCATION (1)			LOCATION (2)			LOCATION (3)		
	"TORSION"	HAND-CALC.	% DIFF	"TORSION"	HAND-CALC.	% DIFF	"TORSION"	HAND-CALC.	% DIFF
NORMAL STRESS									
TORSIONAL	51.791376	51.131	0.91	-15.04127	-14.777	1.76	-1.402-05	0	0
(C/F)									
VAL	24.77335	24.592	0.77	-7.207242	-7.034	1.71	-7.602-06	0	0
BENDING	-3.43367	-3.434	0	-14.33548	-4.652	67.55	-18.98772	0	?
(C/F)									
VAL	-9.43367	-9.434	0	-14.33548	-4.652	67.55	-18.98772	0	?
	-3.43367	-3.434	0	-14.33548	-4.652	67.55	-18.98772	0	?
shear stress									
TORSIONAL	0	0	0	6.317381	6.363	0.71	1.512031	1.414	6.84
(C/F)									
VAL	0	0	0	6.317381	6.363	0.71	1.512031	1.414	6.84
	0	0	0	5.422007	5.313	3.25	1.312571	1.279	6.37
TORSIONAL	3.743765	3.703	0.66	3.074631	3.091	0.52	0.16076	0.151	5.63
(C/F)									
VAL	2.864202	2.805	0.75	2.363753	2.383	0.59	0.123551	0.116	6.34
	1.555937	1.654	0.31	1.362433	1.365	0.14	0.071232	0.067	5.95
TORSIONAL	0.712605	0.733	5.13	0.540433	0.513	5.15	0.000031	0	0
(C/F)									
VAL	1.613375	1.634	1.26	1.129332	1.147	1.28	-6.502-05	0	0

Table 4.21b - "TORSION"/HAND-CALC. COMPARISON, PROBLEM 9b

"TORSION" AND HAND-CALCULATION RESULTS
COMPARISON TABLE

Problem: 10
Beam Selected: C12x30
End Conditions: Fixed-Free

Analyses taken at 3 Locations:

Location 1: 0 inches
Location 2: 32.4 inches
Location 3: 108 inches

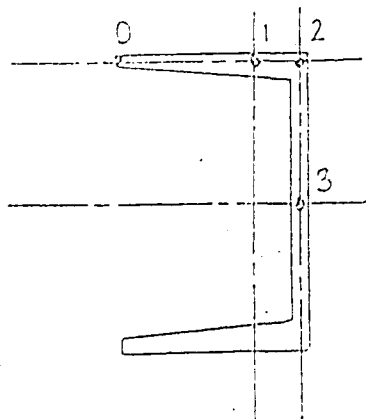
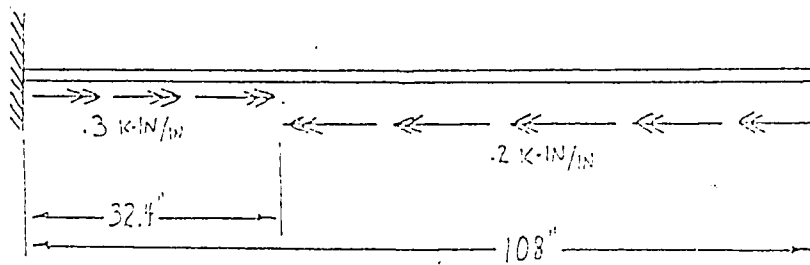

Pt. 0: Flange Tip
Pt. 1: Flange (at Neutral Axis)
Pt. 2: Flange/Web Connection
Pt. 3: Web (at Shear Center)

PROBLEM: 10
 BEAM: C12x30
 Fixed-Free
 Length: 108"

0 in. 32.4 in. 108 in.
 LOCATION (1) LOCATION (2) LOCATION (3)

		LOCATION (1)			LOCATION (2)			LOCATION (3)		
		"TORSION"	HAND-CALC.	% DIFF	"TORSION"	HAND-CALC.	% DIFF	"TORSION"	HAND-CALC.	% DIFF
NORMAL STRESS										

TORSIONAL	OPT. 0	-15.71312	-15.411	1.92	-3.486435	-4.554	23.44	-0.002767	0	0
(Obs)	OPT. 1									
ksi	OPT. 2	-6.719194	-6.612	1.59	-1.490957	-1.954	23.72	-0.001184	0	0

BENDING	OPT. 0	0	0	0	0	0	0	0	0	0
(Obs)	OPT. 1									
ksi	OPT. 2	0	0	0	0	0	0	0	0	0

SHEAR STRESS										

TORSIONAL	OPT. 1	0	0	0	-5.205339	-5.058	2.83	-2.258247	-2.344	3.66
(Obs)	OPT. 2									
ksi	OPT. 3	0	0	0	-5.205339	-5.058	2.83	-2.258247	-2.344	3.66

WARPING	OPT. 1	-0.427952	-0.422	1.39	-0.486022	-0.472	2.89	0.308976	0.303	1.94
(Obs)	OPT. 2									
ksi	OPT. 3	0.171764	-0.169	1.61	-0.39715	-0.395	3.06	0.252493	0.248	1.78

BENDING	OPT. 1									
(Obs)	OPT. 2									
ksi	OPT. 3									

Table 4.22 - "TORSION"/HABD-CALC. COMPARISON, PROBLEM 10

"TORSION" AND HAND-CALCULATION RESULTS
COMPARISON TABLE

Problem: 11
Beam Selected: C5x9
End Conditions: Fixed-Free

Analyses taken at 3 Locations:

Location 1: 0 inches
Location 2: 12.6 inches
Location 3: 42 inches

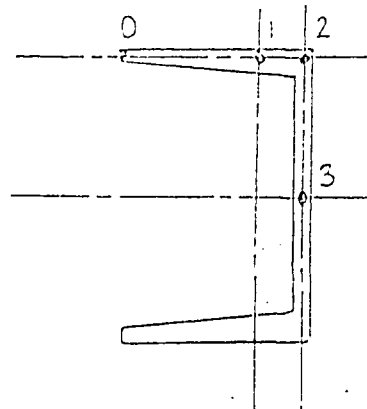
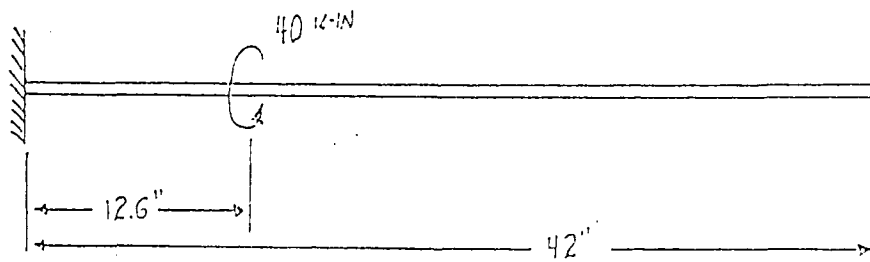

Pt. 0: Flange Tip
Pt. 1: Flange (at Neutral Axis)
Pt. 2: Flange/Web Connection
Pt. 3: Web (at Shear Center)

PROBLEM: 11
 BEAM: C5x9
 Fixed-Free
 Length: 42"

0 in. 12.6 in. 42 in.
 LOCATION (1) LOCATION (2) LOCATION (3)

		LOCATION (1)		LOCATION (2)		LOCATION (3)	
		"TORSION"	HAND-CALC.	% DIFF	"TORSION"	HAND-CALC.	% DIFF
NORMAL STRESS							
TORSIONAL	OPT. 0	235.0199	226.708	3.54	-91.43776	-87.686	4.03
(σ)	OPT. 1						
ksi	OPT. 2	122.4182	119.059	3.56	-47.62851	-45.663	4.13
BENDING	OPT. 0	0	0	0	0	0	0
(σ_b)	OPT. 1	0	0	0	0	0	0
ksi	OPT. 2	0	0	0	0	0	0
shear stress							
TORSIONAL	OPT. 1	0	0	0	35.65666	35.231	1.19
(τ_t)	OPT. 2	0	0	0	35.65666	35.231	1.19
ksi	OPT. 3	0	0	0	35.21379	35.781	1.21
WARPING	OPT. 1	20.46408	20.532	0.33	14.2304	14.399	1.03
(τ_w)	OPT. 2	14.91176	14.971	0.39	10.38397	10.337	0.45
ksi	OPT. 3	-7.34117	-7.37	0.39	-5.112107	-5.169	1.09
BENDING	OPT. 1	0	0	0	0	0	0
(τ_b)	OPT. 2	0	0	0	0	0	0
ksi	OPT. 3	0	0	0	0	0	0

Table 4.23 - "TORSION"/HAND-CALC. COMPARISON, PROBLEM 11

"TORSION" AND HAND-CALCULATION RESULTS
COMPARISON TABLE

Problem: 12
Beam Selected: MC18x42
End Conditions: Fixed-Free

Analyses taken at 3 Locations:

Location 1: 0 inches
Location 2: 96 inches
Location 3: 192 inches

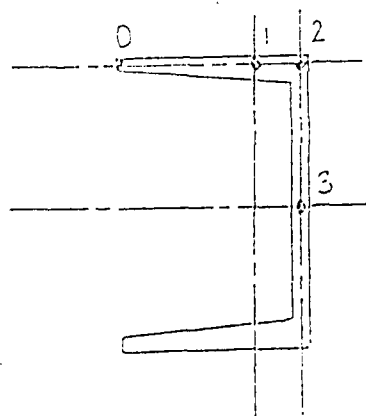
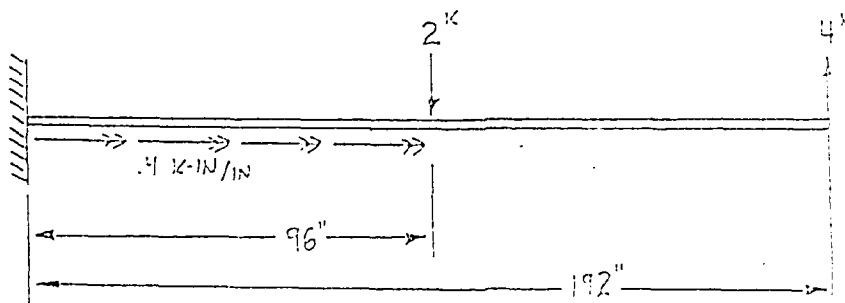

Pt. 0: Flange Tip
Pt. 1: Flange (at Neutral Axis)
Pt. 2: Flange/Web Connection
Pt. 3: Web (at Shear Center)

PROBLEM: 12a (WITH ECCENTRIC TORSION DUE TO CONCENTRATED LOADS)

BEAM: XC18x42

Fixed-Free

Length: 192"

0 in. LOCATION (1)
96 in. LOCATION (2)
192 in. LOCATION (3)

	"TORSION"	HAND-CALC.	% DIFF	"TORSION"	HAND-CALC.	% DIFF	"TORSION"	HAND-CALC.	% DIFF
NORMAL STRESS									
TORSIONAL	OPT. 0	25.37892	23.705	14.56	-4.755027	-2.238	52.93	-0.000161	0
(σ_{ws})	OPT. 1								0
ksi	OPT. 2	11.97417	14.042	14.73	-2.243506	-1.058	52.84	-7.602-05	0
BENDING	OPT. 0	9.35065	9.351	0	12.46753	6.234	49.99	18.7013	0
(σ_b)	OPT. 1	9.35065	9.351	0	12.46753	6.234	49.99	18.7013	0
ksi	OPT. 2	9.35065	9.351	0	12.46753	6.234	49.99	18.7013	0
DIFF									
TORSIONAL	OPT. 1	0	0	0	2.259055	4.768	52.62	0.463438	3.945
(τ_s)	OPT. 2	0	0	0	2.259065	4.768	52.62	0.463438	3.945
ksi	OPT. 3	0	0	0	1.626527	3.433	52.62	0.333675	2.841
WARPING	OPT. 1	1.253714	1.367	8.29	-0.145151	-0.187	22.38	-0.029777	0.014
(τ_{ws})	OPT. 2	0.974622	1.061	8.14	-0.112839	-0.145	22.18	-0.023148	0.011
ksi	OPT. 3	-0.676821	0.738	8.29	0.07836	-0.101	22.42	0.016075	0.008
BENDING	OPT. 1								
(τ_b)	OPT. 2	-0.116926	-0.1138	2.59	-0.115876	-0.1138	2.59	-0.233653	-0.2276
ksi	OPT. 3	0.2384912	0.3041	1.84	0.298491	0.3041	1.84	0.536992	0.6001

Table 4.24a -- "TORSION"/HAND-CALC. COMPARISON, PROBLEM 12a

PROBLEM: 12b (WITHOUT ECCENTRIC TORSION DUE TO CONCENTRATED LOADS)

BEAM: XC18x42

Fixed-Free

Length: 192"

0 in.

36 in.

192 in.

LOCATION (1)			LOCATION (2)			LOCATION (3)				
	"TORSION"	HAND-CALC.	% DIFF	"TORSION"	HAND-CALC.	% DIFF	"TORSION"	HAND-CALC.	% DIFF	
NORMAL STRESS										
TORSIONAL	OPT. 0	25.37892	25.193	0.73	-4.755027	-4.817	1.29	-0.000161	0	0
(σ _{xs})	OPT. 1									
ksi	OPT. 2	11.97417	11.909	0.54	-2.243506	-2.277	1.45	-7.60E-05	0	0
BENDING	OPT. 0	9.35065	9.351	0	12.46753	6.234	49.99	18.7013	0	?
(σ _{zb})	OPT. 1	9.35065	9.351	0	12.46753	6.234	49.99	18.7013	0	?
ksi	OPT. 2	9.35065	9.351	0	12.46753	6.234	49.99	18.7013	0	?
SHEAR STRESS										
TORSIONAL	OPT. 1	0	0	0	2.259065	2.149	4.87	0.463438	0.4298	7.25
(τ _{xy})	OPT. 2	0	0	0	2.259065	2.149	4.87	0.463438	0.4298	7.25
ksi	OPT. 3	0	0	0	1.626527	1.549	4.83	0.333675	0.3095	7.25
WARPING	OPT. 1	1.253714	1.2466	0.59	-0.145151	-0.1386	4.51	0	0	0
(τ _{yz})	OPT. 2	0.974622	0.9672	0.76	-0.112839	-0.1075	4.69	0	0	0
ksi	OPT. 3	-0.676921	0.6726	0.62	0.07836	-0.0749	4.54	0	0	0
BENDING	OPT. 1									
(τ _{zb})	OPT. 2	-0.116926	-0.1138	2.59	-0.116826	-0.1138	2.59	-0.233653	-0.2276	2.59
ksi	OPT. 3	0.2984912	0.3041	1.84	0.298491	0.3041	1.84	0.596982	0.6091	1.85

Table 4.24b - "TORSION"/HAND-CALC. COMPARISON, PROBLEM 12b

Chapter Five

"GTSTRU DL" STRESS ANALYSIS

5.1 General

The twelve hand-calculated test problems that were determined through use of the Torsional Analysis Case Charts were compared to the same test problems analyzed with GTSTRU DL. After the combined bending/torsional stresses were determined for each of the test problems, the results were compared to the plane bending and shear stresses computed by GTSTRU DL.

These comparisons showed how the torsionally-induced stresses can either increase or decrease the overall bending and shear stresses at various points in the member's cross-section and at various locations along the member's length.

5.2 GTSTRU DL Program Input and Output Files

Input files for each test problem was established using the standard GTSTRU DL format of specified units, joint coordinates, member indices, constants and member loadings. In addition, the GTSTRU DL "Tables" sub-program for specific member properties were used.

Stiffness analyses were performed, and stress outputs were listed for each specified location along the member's length and at specified key points of the member's cross-section.

Joint release requirements for GTSTRU DL dictated that the torsional pinned end condition could be attained through release of the y-axis and z-axis moments. Release of the x-axis moment would create an unstable member, and was similar to the pinned boundary requirements for both the Torsional Analysis Case Charts and the "TORSION" program. Currently,

GTSTRU DL stiffness analysis does not include torsional and warping stresses, and therefore, only plane bending stresses are listed in the program output.

The GTSTRU DL Input/Output file printouts for each test problem are shown in Appendix D.

5.3 Comparison of GTSTRU DL and Hand-Calculated Stress Results

Tables 5.1 through 5.12 illustrate the comparison of overall member cross-sectional stress derived by GTSRU DL and hand-calculations.

The basic comparison between the GTSTRU DL stress determination and the hand-calculated stresses is the difference caused by the torsional and warping stresses. The combined bending and torsional stresses are based on the plane bending loads and the torsional bending loads. If the plane bending loads are small, then their percentage of the overall combined stress will also be small. In comparison to the GTSTRU DL stress calculations (which were based on plane bending loads), the percent differences can seem large. However, this is due to the magnitudes of the plane bending loads and torsional loads chosen for each test problem, making the percent differences based upon the relative amounts of plane bending and torsional stresses in each test problem.

"STRUPL" AND HAND-CALCULATION RESULTS
COMPARISON TABLE

Problem: 1
Beam Selected: W14x109
End Conditions: Fixed-Free

Analyses taken at 3 Locations:

Location 1: 0 inches
Location 2: 210 inches
Location 3: 300 inches

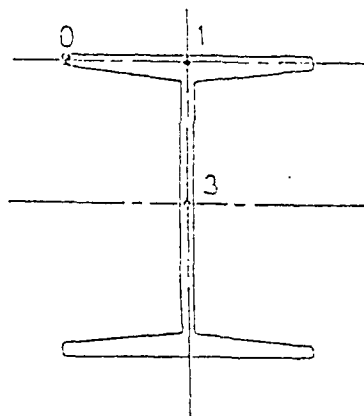
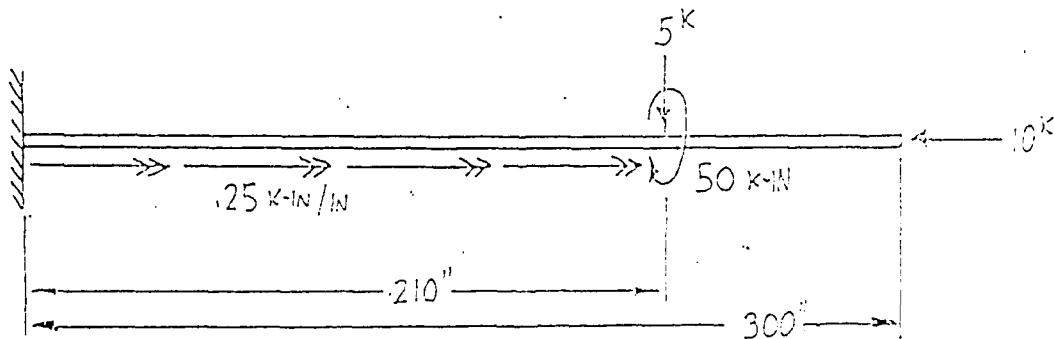

Pt. 0: Flange Tip
Pt. 1: Flange/Web Connection
Pt. 3: Web (at Neutral Axis)

Location	Pt.	"STRU DL" Results	"Hand-Calc" Results	% Diff
=====				
W14x109	0	Bending (σ_b): -6.069365 Total: -6.069365	Bending (σ_b): -6.0694 Torsional (σ_w): 16.28415 Total: 10.21475	0% 40.6%
0 in.	1	Bending (τ_b): .1981687 Total: .1981687	Bending (τ_b): .1932 Torsional (τ_t): 0 Warping (τ_{ws}): .9088 Total: 1.102	2.5% 82.0%
	3	Bending (τ_b): 7.292585 Total: 7.292585	Bending (τ_b): .7366 Torsional (τ_t): 0 Total: .7366	1.0% 1.0%
=====				
	0	Bending (σ_b): 0 Total: 0	Bending (σ_b): 0 Torsional (σ_w): -4.86199 Total: -4.86199	0% --
210 in.	1	Bending (τ_b): .1981687 Total: .1981687	Bending (τ_b): .1932 Torsional (τ_t): 3.76226 Warping (τ_{ws}): .1624 Total: 4.11786	2.5% 95.2%
	3	Bending (τ_b): .7292585 Total: .7292585	Bending (τ_b): .7366 Torsional (τ_t): 2.29673 Total: 3.0333	75.9%
=====				
	0	Bending (σ_b): 0 Total: 0	Bending (σ_b): 0 Torsional (σ_w): 0 Total: 0	0% 0%
300 in.	1	Bending (τ_b): 0 Total: 0	Bending (τ_b): 0 Torsional (τ_t): 1.95009 Warping (τ_{ws}): -.1428 Total: 1.80729	0% --
	3	Bending (τ_b): 0 Total: 0	Bending (τ_b): 0 Torsional (τ_t): 1.19046 Total: 1.19046	0% --
=====				

Table 5.1 - STRU DL/HAND-CALC. COMPARISON, PROBLEM 1

"STRU DL" AND HAND-CALCULATION RESULTS
COMPARISON TABLE

Problem: 2
Beam Selected: W14x159
End Conditions: Pinned-Fixed

Analyses taken at 3 Locations:

Location 1: 0 inches
Location 2: 108 inches
Location 3: 432 inches

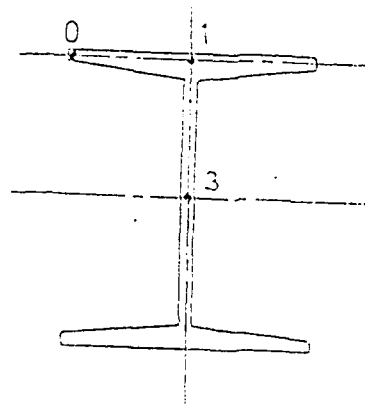
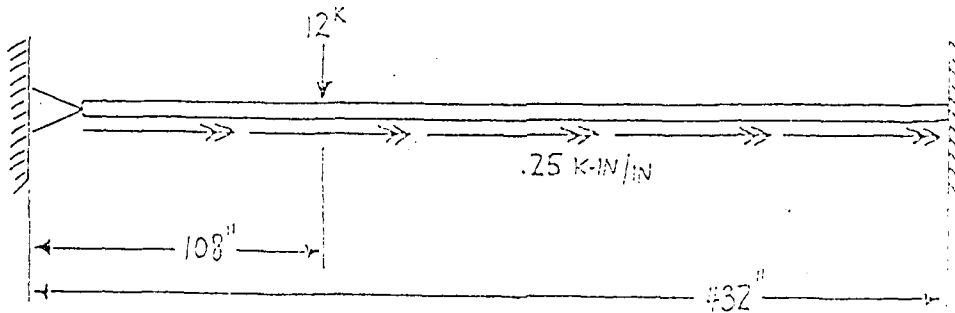

Pl. 0: Flange Tip
Pl. 1: Flange/Web Connection
Pl. 3: Web (at Neutral Axis)

Location	Pt.	"STRU DL" Results	"Hand-Calc" Results	% Diff
=====				
W14x159	0	Bending (σ_b): 0	Bending (σ_b): 0	0%
		Total: 0	Torsional (σ_w): 0	
			Total: 0	0%
0 in.	1	Bending (τ_b): .2147443	Bending (τ_b): .206	4.1%
		Total: .2147443	Torsional (τ_t): 1.642	
			Warping (τ_w): .100	
			Total: 1.948	88.9%
	3	Bending (τ_b): .7654468	Bending (τ_b): .767	0.2%
		Total: .7654468	Torsional (τ_t): 1.028	
			Total: 1.795	57.4%
=====				
	0	Bending (σ_b): 3.233046	Bending (σ_b): 3.227	0.2%
		Total: 3.233046	Torsional (σ_w): -1.317	
			Total: 1.91	40.9%
108 in.	1	Bending (τ_b): .2147443	Bending (τ_b): .206	4.1%
		Total: .2147443	Torsional (τ_t): .924	
			Warping (τ_w): .020	
			Total: 1.15	81.3%
	3	Bending (τ_b): .7654468	Bending (τ_b): .767	0.2%
		Total: .7654468	Torsional (τ_t): .678	
			Total: 1.345	43.1%
=====				
	0	Bending (σ_b): -2.374903	Bending (σ_b): -2.392	0.7%
		Total: -2.374903	Torsional (σ_w): -4.17	
			Total: -5.562	63.8%
432 in.	1	Bending (τ_b): .1241631	Bending (τ_b): .120	3.4%
		Total: .1241631	Torsional (τ_t): 0	
			Warping (τ_w): -.330	
			Total: -.210	43.3%
	3	Bending (τ_b): .4425741	Bending (τ_b): .446	0.9%
		Total: .4425741	Torsional (τ_t): 0	
			Total: .446	0.8%
=====				

Table 5.2 - STRU DL/HAND-CALC. COMPARISON, PROBLEM 2

"STRUDL" AND HAND-CALCULATION RESULTS
COMPARISON TABLE

Problem: 3
Beam Selected: W12x79
End Conditions: Pinned-Pinned

Analyses taken at 4 Locations:

Location 1: 0 inches
Location 2: 36 inches
Location 3: 252 inches
Location 4: 360 inches

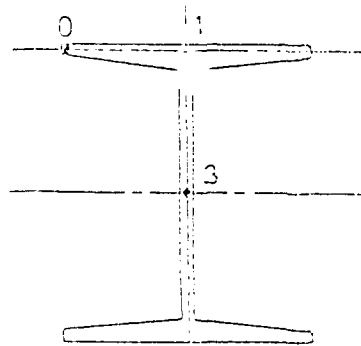
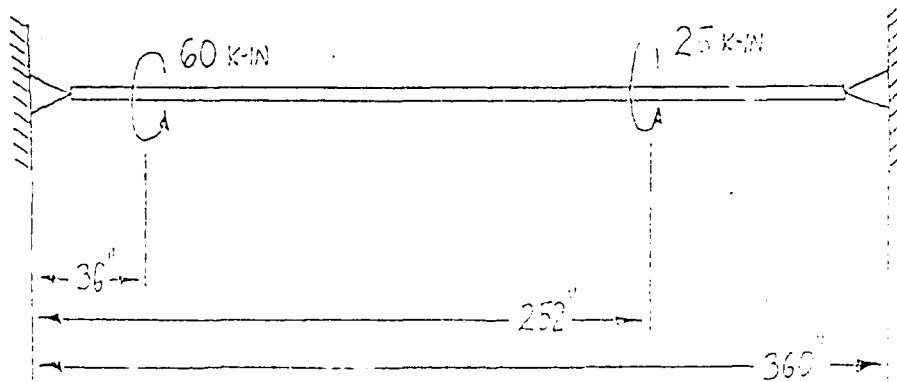

Pl. 0: Flange Tip
Pl. 1: Flange/Web Connection
Pl. 3: Web (at Neutral Axis)

Location	Pt.	"STRU DL" Results	"Hand-Calc" Results	% Diff
=====				
W12x79	0	Bending (σ_b): 0 Total: 0	Bending (σ_b): 0 Torsional (σ_w): 0 Total: 0	0% 0%
0 in.	1	Bending (τ_b): 0 Total: 0	Bending (τ_b): 0 Torsional (τ_t): 4.62 Warping (τ_w): .541 Total: 5.161	0% --
	3	Bending (τ_b): 0 Total: 0	Bending (τ_b): 0 Torsional (τ_t): 2.95 Total: 2.95	0% --
=====				
	0	Bending (σ_b): 0 Total: 0	Bending (σ_b): 0 Torsional (σ_w): -6.297 Total: -6.297	0% --
36 in.	1	Bending (τ_b): 0 Total: 0	Bending (τ_b): 0 Torsional (τ_t): 3.70 Warping (τ_w): .611 Total: 4.311	0% --
	3	Bending (τ_b): 0 Total: 0	Bending (τ_b): 0 Torsional (τ_t): 2.37 Total: 2.37	0% --
=====				
	0	Bending (σ_b): 0 Total: 0	Bending (σ_b): 0 Torsional (σ_w): -4.271 Total: -4.271	0% --
252 in.	1	Bending (τ_b): 0 Total: 0	Bending (τ_b): 0 Torsional (τ_t): -1.78 Warping (τ_w): -.206 Total: -1.986	0% --
	3	Bending (τ_b): 0 Total: 0	Bending (τ_b): 0 Torsional (τ_t): -1.14 Total: -1.14	0% --
=====				
	0	Bending (σ_b): 0 Total: 0	Bending (σ_b): 0 Torsional (σ_w): 0 Total: 0	0% 0%
360 in.	1	Bending (τ_b): 0 Total: 0	Bending (τ_b): 0 Torsional (τ_t): -3.28 Warping (τ_w): -.092 Total: -3.372	0% --
	3	Bending (τ_b): 0 Total: 0	Bending (τ_b): 0 Torsional (τ_t): -2.10 Total: -2.10	0% --
=====				

Table 5.3 - STRU DL/HAND-CALC. COMPARISON, PROBLEM 3

"STRU DL" AND HAND-CALCULATION RESULTS
COMPARISON TABLE

Problem: 4.
Beam Selected: W14x90
End Conditions: Fixed-Fixed

Analyses taken at 3 Locations:

Location 1: 0 inches
Location 2: 240 inches
Location 3: 480 inches

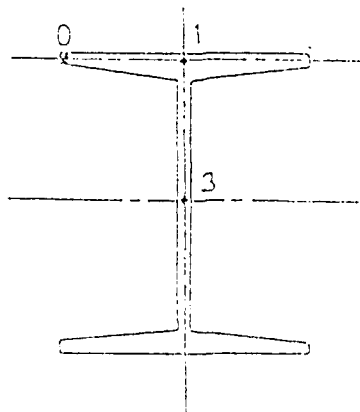
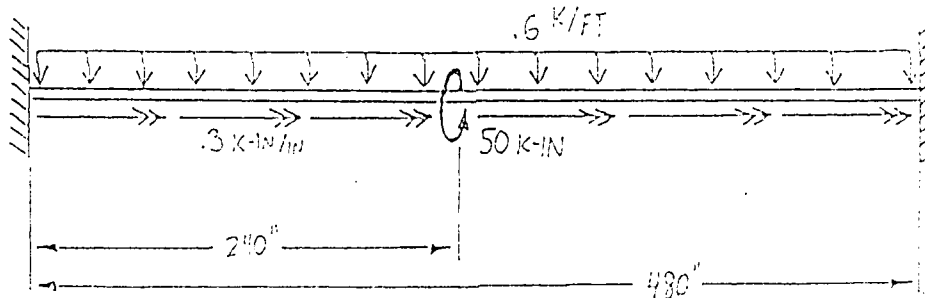

Pt. 0: Flange Tip
Pt. 1: Flange/Web Connection
Pt. 3: Web (at Neutral Axis)

Location	Pt.	"STRU DL" Results	"Hand-Calc" Results	% Diff
=====				
W14x90	0	Bending (σ_b): -6.713287 Total: -6.713287	Bending (σ_b): -6.7133 Torsional (σ_w): 18.99 Total: 12.2767	0% 45.3%
0 in.	1	Bending (τ_b): .580364 Total: .580364	Bending (τ_b): .5701 Torsional (τ_t): 0 Warping (τ_w): 1.07 Total: 1.6401	1.8% 64.6%
	3	Bending (τ_b): -2.111372 Total: -2.111372	Bending (τ_b): -2.1376 Torsional (τ_t): 0 Total: -2.1376	1.2% 1.2%
=====				
	0	Bending (σ_b): 3.356643 Total: 3.356643	Bending (σ_b): 3.3568 Torsional (σ_w): -11.30 Total: -7.9434	0% -57.7%
240 in.	1	Bending (τ_b): 0 Total: 0	Bending (τ_b): 0 Torsional (τ_t): 0 Warping (τ_w): .28 Total: .28	0% --
	3	Bending (τ_b): 0 Total: 0	Bending (τ_b): 0 Torsional (τ_t): 0 Total: 0	0% 0%
=====				
	0	Bending (σ_b): -6.713287 Total: -6.713287	Bending (σ_b): -6.7133 Torsional (σ_w): 18.99 Total: 12.2767	0% 45.3%
480 in.	1	Bending (τ_b): .500364 Total: .500364	Bending (τ_b): .5701 Torsional (τ_t): 0 Warping (τ_w): -1.07 Total: -.4999	1.8% 13.9%
	3	Bending (τ_b): 2.111372 Total: 2.111372	Bending (τ_b): 2.1376 Torsional (τ_t): 0 Total: 2.1376	1.2% 1.2%
=====				

Table 5.4 - STRU DL/HAND-CALC. COMPARISON, PROBLEM 4

"STRUJL" AND HAND-CALCULATION RESULTS
COMPARISON TABLE

Problem: 5
Beam Selected: W8x15
End Conditions: Fixed-Free

Analyses taken at 3 Locations:

Location 1: 0 inches
Location 2: 18 inches
Location 3: 60 inches

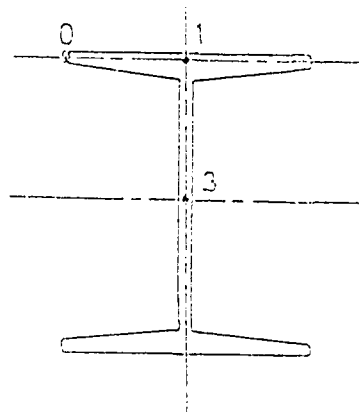
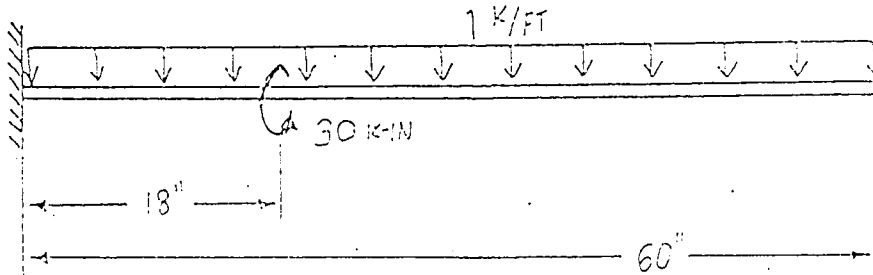

Pl. 0: Flange Tip
Pl. 1: Flange/Web Connection
Pl. 3: Web (at Neutral Axis)

Location	Pt.	"STRUOL" Results	"Hand-Calc" Results	% Diff
=====				
W8x15	0	Bending (σ_b): -12.71136	Bending (σ_b): -12.712	0%
		Total: -12.71136	Torsional (σ_w): 52.749	
			Total: 50.037	74.6%
0 in.	1	Bending (τ_b): .8144448	Bending (τ_b): .787	3.4%
		Total: .8144448	Torsional (τ_t): 0	
			Warping (τ_w): 4.543	84.7%
		Total: 5.33		
	3	Bending (τ_b): 2.816950	Bending (τ_b): 2.883	2.3%
		Total: 2.816950	Torsional (τ_t): 0	
			Total: 2.883	2.3%
=====				
	0	Bending (σ_b): -6.228563	Bending (σ_b): -6.229	0%
		Total: -6.228563	Torsional (σ_w): -12.834	
			Total: -19.063	67.3%
18 in.	1	Bending (τ_b): .5701113	Bending (τ_b): .551	3.4%
		Total: .5701113	Torsional (τ_t): 6.948	
			Warping (τ_w): 4.089	95.1%
		Total: 11.588		
	3	Bending (τ_b): 1.971865	Bending (τ_b): 2.018	2.3%
		Total: 1.971865	Torsional (τ_t): 5.404	
			Total: 7.422	71.1%
=====				
	0	Bending (σ_b): 0	Bending (σ_b): 0	0%
		Total: 0	Torsional (σ_w): 0	
			Total: 0	0%
60 in.	1	Bending (τ_b): 0	Bending (τ_b): 0	0%
		Total: 0	Torsional (τ_t): 2.779	
			Warping (τ_w): -1.182	--
		Total: 2.597		
	3	Bending (τ_b): 0	Bending (τ_b): 0	0%
		Total: 0	Torsional (τ_t): 2.162	
			Total: 2.162	--
=====				

Table 5.5 - STRUOL/HAND-CALC. COMPARISON, PROBLEM 5

"STRUCL" AND HAND-CALCULATION RESULTS
COMPARISON TABLE

Problem: 6
Beam Selected: W10x49
End Conditions: Fixed-Free

Analyses taken at 3 Locations:

Location 1: 0 inches
Location 2: 96 inches
Location 3: 192 inches

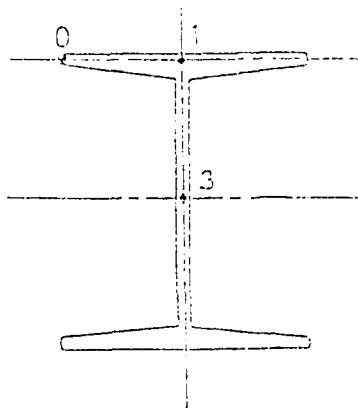
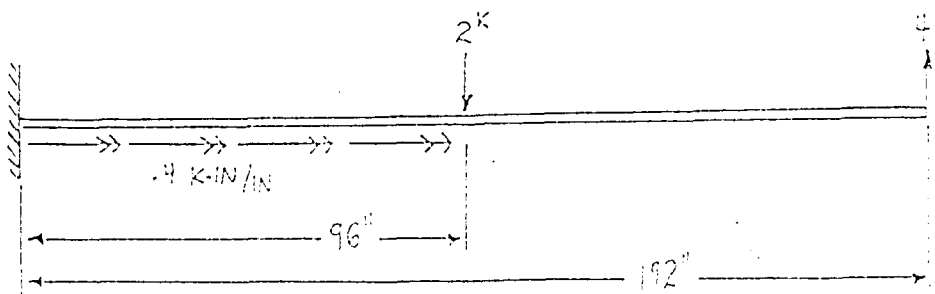

0. 0. Flange Top
1. 1. Flange/Web Connection
3. 3. Web (at Neutral Axis)

Location	Pt.	"STRUOL" Results	"Hand-Calc" Results	% Diff
W10x49	0	Bending (σ_b): 10.54945 Total: 10.54945	Bending (σ_b): 10.549 Torsional (σ_w): 12.752 Total: 23.301	0% 54.7%
	1	Bending (τ_b): -.1729304 Total: -.1729304	Bending (τ_b): -.171 Torsional (τ_w): 0 Warping (τ_w): 1.060 Total: .889	1.1% 80.5%
	3	Bending (τ_b): -.6398947 Total: -.6398947	Bending (τ_b): -.653 Torsional (τ_w): 0 Total: -.653	2.0% 2.0%
96 in.	0	Bending (σ_b): 7.032968 Total: 7.032968	Bending (σ_b): 7.033 Torsional (σ_w): -2.48 Total: 4.553	0% 35.3%
	1	Bending (τ_b): -.2921956 Total: -.2921956	Bending (τ_b): -.341 Torsional (τ_w): 1.519 Warping (τ_w): -.106 Total: 1.072	14.3% 72.7%
	3	Bending (τ_b): -.6398947 Total: -.6398947	Bending (τ_b): -.653 Torsional (τ_w): .922 Total: .269	2.0% 60.0%
192 in.	0	Bending (σ_b): 0 Total: 0	Bending (σ_b): 0 Torsional (σ_w): 0 Total: 0	0% 0%
	1	Bending (τ_b): -.3458608 Total: -.3458608	Bending (τ_b): -.341 Torsional (τ_w): .751 Warping (τ_w): -.035 Total: .385	1.4% 10.2%
	3	Bending (τ_b): -1.279789 Total: -1.279789	Bending (τ_b): -1.306 Torsional (τ_w): .461 Total: -.845	2.0% 34.0%

Table 5.6 - STRUOL/HAND-CALC. COMPARISON, PROBLEM 6

"STRUDL" AND HAND-CALCULATION RESULTS
COMPARISON TABLE

Problem: 7
Beam Selected: W6x15
End Conditions: Fixed-Free

Analyses taken at 3 Locations:

Location 1: 0 inches
Location 2: 12.6 inches
Location 3: 42 inches

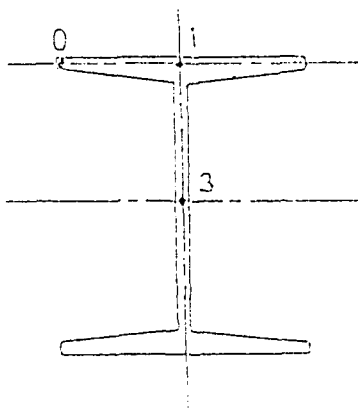
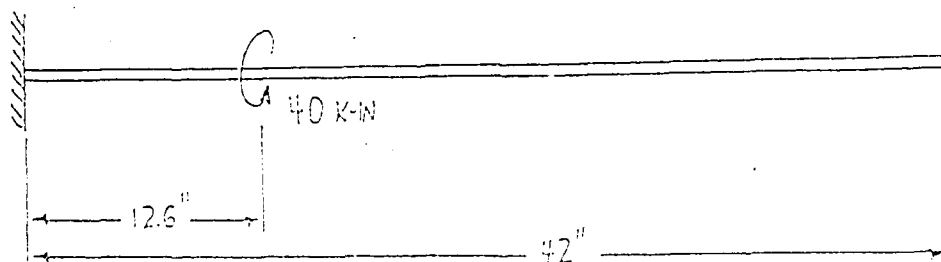

Pt. 0: Flange Tip
Pt. 1: Flange/Web Connection
Pt. 3: Web (at Neutral Axis)

Location	Pt.	"STRU DL" Results	"Hand-Calc" Results	% Diff
=====				
W6x15	0	Bending (σ_b): 0	Bending (σ_b): 0	0%
		Total: 0	Torsional (σ_w): 52.272	
			Total: 52.272	--
0 in.	1	Bending (τ_b): 0	Bending (τ_b): 0	0%
		Total: 0	Torsional (τ_t): 0	
			Warping (τ_w): 6.810	
			Total: 6.810	--
	3	Bending (τ_b): 0	Bending (τ_b): 0	0%
		Total: 0	Torsional (τ_t): 0	
			Total: 0	0%
=====				
	0	Bending (σ_b): 0	Bending (σ_b): 0	0%
		Total: 0	Torsional (σ_w): -4.021	
			Total: -4.021	--
12.6 in.	1	Bending (τ_b): 0	Bending (τ_b): 0	0%
		Total: 0	Torsional (τ_t): 4.160	
			Warping (τ_w): 6.605	
			Total: 10.765	--
	3	Bending (τ_b): 0	Bending (τ_b): 0	0%
		Total: 0	Torsional (τ_t): 3.680	
			Total: 3.680	--
=====				
	0	Bending (σ_b): 0	Bending (σ_b): 0	0%
		Total: 0	Torsional (σ_w): 0	
			Total: 0	0%
42 in.	1	Bending (τ_b): 0	Bending (τ_b): 0	0%
		Total: 0	Torsional (τ_t): 3.120	
			Warping (τ_w): -1.204	
			Total: 2.916	--
	3	Bending (τ_b): 0	Bending (τ_b): 0	0%
		Total: 0	Torsional (τ_t): 2.760	
			Total: 2.760	--
=====				

Table 5.7 - STRU DL/HAND-CALC. COMPARISON, PROBLEM 7

"STRUDL" AND HAND-CALCULATION RESULTS
COMPARISON TABLE

Problem: 8
Beam Selected: W8x67
End Conditions: Fixed-Free

Analyses taken at 3 Locations:

Location 1: 0 inches
Location 2: 32.4 inches
Location 3: 108 inches

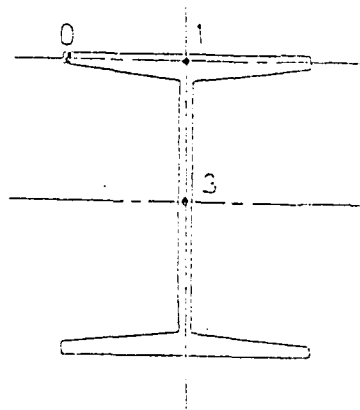
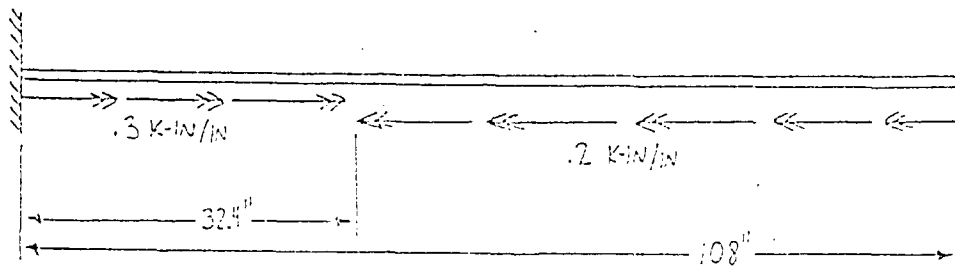

Pt. 0: Flange Tip
Pt. 1: Flange/Web Connection
Pt. 3: Web/Web Neutral Axis

Location	Pt.	"STRU DL" Results	"Hand-Calc" Results	% Diff
=====				
W8x67	0	Bending (σ_b): 0	Bending (σ_b): 0	0%
		Total: 0	Torsional (σ_w): -2.997	
			Total: -2.997	--
0 in.	1	Bending (σ_b): 0	Bending (σ_b): 0	0%
		Total: 0	Torsional (σ_w): 0	
			Warping (τ_w): -.130	
			Total: -.130	--
	3	Bending (σ_b): 0	Bending (σ_b): 0	0%
		Total: 0	Torsional (σ_w): 0	
			Total: 0	0%
=====				
	0	Bending (σ_b): 0	Bending (σ_b): 0	0%
		Total: 0	Torsional (σ_w): -.699	
			Total: -.699	--
32.4 in.	1	Bending (σ_b): 0	Bending (σ_b): 0	0%
		Total: 0	Torsional (σ_w): -.1486	
			Warping (τ_w): -.169	
			Total: -1.605	--
	3	Bending (σ_b): 0	Bending (σ_b): 0	0%
		Total: 0	Torsional (σ_w): -.875	
			Total: -.875	--
=====				
	0	Bending (σ_b): 0	Bending (σ_b): 0	0%
		Total: 0	Torsional (σ_w): 0	
			Total: 0	0%
108 in.	1	Bending (σ_b): 0	Bending (σ_b): 0	0%
		Total: 0	Torsional (σ_w): -.856	
			Warping (τ_w): .104	
			Total: -.752	--
	3	Bending (σ_b): 0	Bending (σ_b): 0	0%
		Total: 0	Torsional (σ_w): -.522	
			Total: -.522	--
=====				

Table 5.8 - STRU DL/HAND-CALC. COMPARISON, PROBLEM 3

"STRUDEL" AND HAND-CALCULATION RESULTS
COMPARISON TABLE

Problem: 9
Beam Selected: C10x20
End Conditions: Fixed-Free

Analyses taken at 3 Locations:

Location 1: 0 inches
Location 2: 18 inches
Location 3: 60 inches

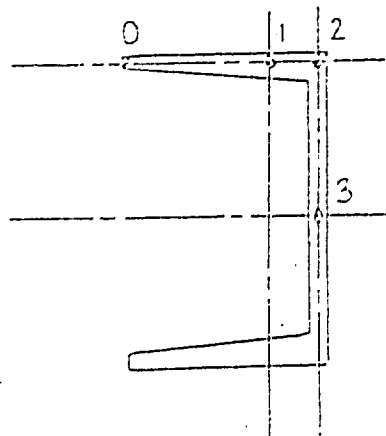
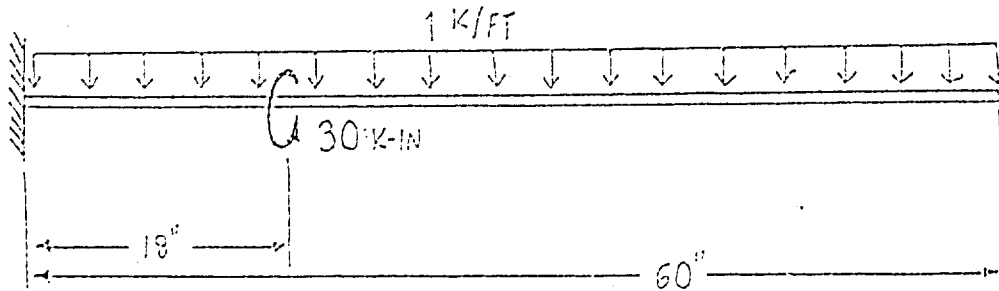

Pt. 0: Flange Tip
Pt. 1: Flange (at Neutral Axis)
Pt. 2: Flange/Web Connection
Pt. 3: Web (at Shear Center)

Location	Pt.	"STRU DL" Results	"Hand-Calc" Results	% Diff
C10x20	0	Bending (σ_b): -9.493291	Bending (σ_b): -9.494	0%
		Total: -9.493291	Torsional (σ_w): 63.157	
			Total: 53.563	82.3%
	1	Bending (σ_b): -9.493291	Bending (σ_b): -9.494	0%
		Total: -9.493291	Torsional (σ_w): 30.276	
			Total: 20.782	54.3%
	2	Bending (τ_b): .7725742	Bending (τ_b): .733	5.1%
		Total: .7725742	Torsional (τ_t): 0	
			Warping (τ_{ws}): 3.502	
	3	Bending (τ_b): 1.613310	Bending (τ_b): 1.634	1.3%
		Total: 1.613310	Torsional (τ_t): 0	
			Warping (τ_{ws}): 2.006	
0 in.	0	Bending (σ_b): -4.651712	Bending (σ_b): -4.652	0%
		Total: -4.651712	Torsional (σ_w): -12.995	
			Total: -17.647	73.6%
	1	Bending (σ_b): -4.651712	Bending (σ_b): -4.652	0%
		Total: -4.651712	Torsional (σ_w): -6.229	
			Total: -10.881	57.2%
	2	Bending (τ_b): .5408019	Bending (τ_b): .513	5.1%
		Total: .5408019	Torsional (τ_t): 8.658	
			Warping (τ_{ws}): 2.601	
	3	Bending (τ_b): 1.129317	Bending (τ_b): 1.144	1.3%
		Total: 1.129317	Torsional (τ_t): 7.526	
			Warping (τ_{ws}): 1.490	
18 in.	0	Bending (σ_b): 0	Bending (σ_b): 0	0%
		Total: 0	Torsional (σ_w): 0	
			Total: 0	0%
	1	Bending (σ_b): 0	Bending (σ_b): 0	0%
		Total: 0	Torsional (σ_w): 0	
			Total: 0	0%
	2	Bending (τ_b): 0	Bending (τ_b): 0	0%
		Total: 0	Torsional (τ_t): 3.105	
			Warping (τ_{ws}): .255	
	3	Bending (τ_b): 0	Bending (τ_b): 0	0%
		Total: 0	Torsional (τ_t): 2.699	
			Warping (τ_{ws}): .146	
60 in.	0	Bending (σ_b): 0	Bending (σ_b): 0	0%
		Total: 0	Torsional (σ_w): 0	
			Total: 0	0%
	1	Bending (σ_b): 0	Bending (σ_b): 0	0%
		Total: 0	Torsional (σ_w): 0	
			Total: 0	0%
	2	Bending (τ_b): 0	Bending (τ_b): 0	0%
		Total: 0	Torsional (τ_t): 3.105	
			Warping (τ_{ws}): .255	
	3	Bending (τ_b): 0	Bending (τ_b): 0	0%
		Total: 0	Torsional (τ_t): 2.699	
			Warping (τ_{ws}): .146	
		Total: 0	Total: 2.845	--

Table 5.9 - STRU DL/HAND-CALC. COMPARISON, PROBLEM 9

"STRUOL" AND HAND-CALCULATION RESULTS
COMPARISON TABLE

Problem: 10
Beam Selected: C12x30
End Conditions: Fixed-Free

Analyses taken at 3 Locations:

Location 1: 0 inches
Location 2: 32.4 inches
Location 3: 108 inches

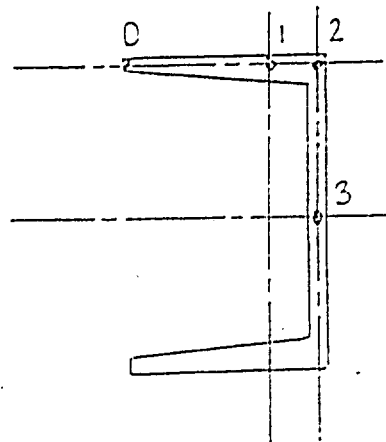
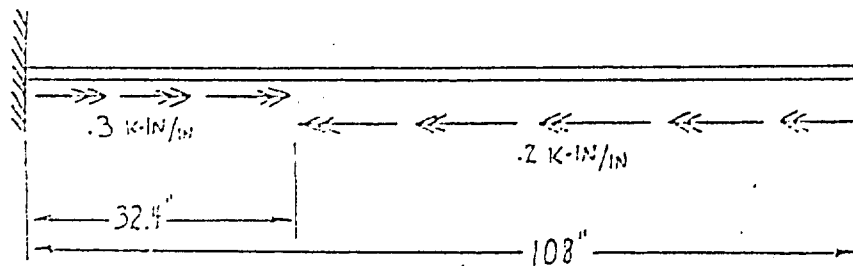

Pt. 0: Flange Tip
Pt. 1: Flange (at Neutral Axis)
Pt. 2: Flange/Web Connection
Pt. 3: Web (at Shear Center)

Location	Pt.	"STRU DL" Results	"Hand-Calc" Results	% Diff	
C12x30	0	Bending (σ_b): 0	Bending (σ_b): 0	0%	
		Total: 0	Torsional (σ_w): -15.411		
			Total: -15.411	--	
	1	Bending (σ_b): 0	Bending (σ_b): 0	0%	
		Total: 0	Torsional (σ_w): -6.612		
			Total: -6.612	--	
	0 in.	2	Bending (τ_b): 0	Bending (τ_b): 0	0%
			Total: 0	Torsional (τ_t): 0	
				Warping (τ_{ws}): -.344	
			Total: -.344	--	
		3	Bending (τ_b): 0	Bending (τ_b): 0	0%
			Total: 0	Torsional (τ_t): 0	
			Warping (τ_{ws}): -.169		
		Total: -.169	--		
32.4 in.	0	Bending (σ_b): 0	Bending (σ_b): 0	0%	
		Total: 0	Torsional (σ_w): -4.554		
			Total: -4.554	--	
	1	Bending (σ_b): 0	Bending (σ_b): 0	0%	
		Total: 0	Torsional (σ_w): -1.954		
			Total: -1.954	--	
	2	Bending (τ_b): 0	Bending (τ_b): 0	0%	
		Total: 0	Torsional (τ_t): -5.058		
			Warping (τ_{ws}): -.385		
			Total: -5.443	--	
	3	Bending (τ_b): 0	Bending (τ_b): 0	0%	
		Total: 0	Torsional (τ_t): -5.149		
		Warping (τ_{ws}): -.189			
		Total: -5.338	--		
108 in.	0	Bending (σ_b): 0	Bending (σ_b): 0	0%	
		Total: 0	Torsional (σ_w): 0		
			Total: 0	0%	
	1	Bending (σ_b): 0	Bending (σ_b): 0	0%	
		Total: 0	Torsional (σ_w): 0		
			Total: 0	0%	
	2	Bending (τ_b): 0	Bending (τ_b): 0	0%	
		Total: 0	Torsional (τ_t): -2.344		
			Warping (τ_{ws}): .248		
			Total: -2.096	--	
	3	Bending (τ_b): 0	Bending (τ_b): 0	0%	
		Total: 0	Torsional (τ_t): -2.386		
		Warping (τ_{ws}): .122			
		Total: -2.264	--		

Table 5.10 - STRU DL/HAND-CALC. COMPARISON, PROBLEM 10

"STRUPL" AND HAND-CALCULATION RESULTS
COMPARISON TABLE

Problem: 11
Beam Selected: C5x9
End Conditions: Fixed-Free

Analyses taken at 3 Locations:

Location 1: 0 inches
Location 2: 12.6 inches
Location 3: 42 inches

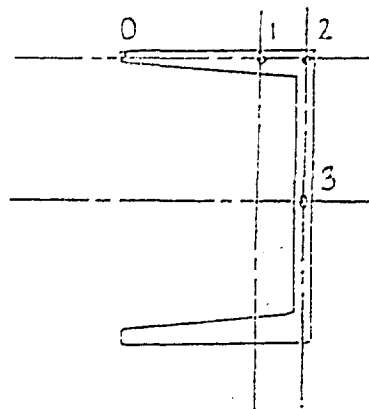
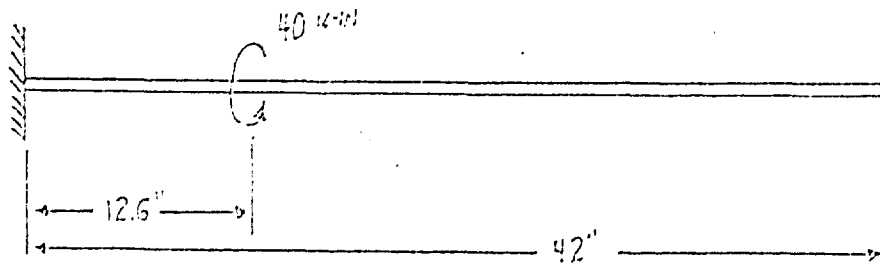

Pt. 0: Flange Tip
Pt. 1: Flange (at Neutral Axis)
Pt. 2: Flange/Web Connection
Pt. 3: Web (at Shear Center)

<u>Location</u>	<u>Pt.</u>	<u>"STRU DL" Results</u>	<u>"Hand-Calc" Results</u>	<u>% Diff</u>
C5x9	0	Bending (σ_b): 0	Bending (σ_b): 0	0%
		Total: 0	Torsional (σ_w): 226.708	--
			Total: 226.708	--
	1	Bending (σ_b): 0	Bending (σ_b): 0	0%
		Total: 0	Torsional (σ_w): 118.059	--
			Total: 118.059	--
0 in.	2	Bending (τ_b): 0	Bending (τ_b): 0	0%
		Total: 0	Torsional (τ_t): 0	--
			Warping (τ_w): 14.971	--
			Total: 14.971	--
	3	Bending (τ_b): 0	Bending (τ_b): 0	0%
		Total: 0	Torsional (τ_t): 0	--
			Warping (τ_w): -7.370	--
			Total: -7.370	--
	0	Bending (σ_b): 0	Bending (σ_b): 0	0%
		Total: 0	Torsional (σ_w): -87.686	--
			Total: -87.686	--
	1	Bending (σ_b): 0	Bending (σ_b): 0	0%
		Total: 0	Torsional (σ_w): -45.663	--
			Total: -45.663	--
12.6 in.	2	Bending (τ_b): 0	Bending (τ_b): 0	0%
		Total: 0	Torsional (τ_t): 35.231	--
			Warping (τ_w): 10.337	--
			Total: 45.568	--
	3	Bending (τ_b): 0	Bending (τ_b): 0	0%
		Total: 0	Torsional (τ_t): 35.781	--
			Warping (τ_w): -5.169	--
			Total: 30.612	--
	0	Bending (σ_w): 0	Bending (σ_w): 0	0%
		Total: 0	Torsional (σ_w): 0	0%
			Total: 0	0%
	1	Bending (σ_b): 0	Bending (σ_b): 0	0%
		Total: 0	Torsional (σ_w): 0	0%
			Total: 0	0%
42 in.	2	Bending (τ_t): 0	Bending (τ_t): 0	0%
		Total: 0	Torsional (τ_t): 2.348	--
			Warping (τ_w): -.299	--
			Total: 2.049	--
	3	Bending (τ_b): 0	Bending (τ_b): 0	0%
		Total: 0	Torsional (τ_t): 2.384	--
			Warping (τ_w): .147	--
			Total: 2.531	--

Table 5.11 - STRU DL/HAND-CALC. COMPARISON, PROBLEM 11

"STRUPL" AND HAND-CALCULATION RESULTS
COMPARISON TABLE

Problem: 12
 Beam Selected: MC18x42
 End Conditions: Fixed-Free

Analyses taken at 3 Locations:

Location 1: 0 inches
 Location 2: 96 inches
 Location 3: 192 inches

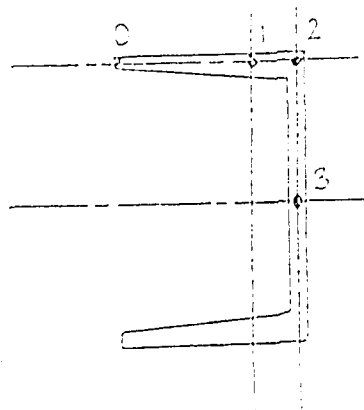
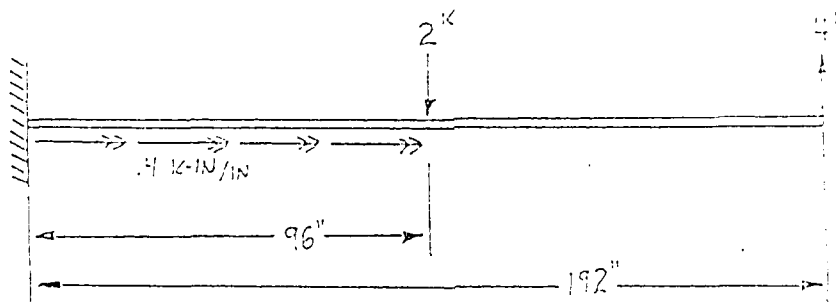

- PL. 01: Flange Top
- PL. 02: Flange (at Neutral Axis)
- PL. 03: Flange/Web Connection
- PL. 04: Web (at Shear Center)

Location	Pt.	"STRU DL" Results	"Hand-Calc" Results	% Diff
MC18x42	0	Bending (σ_b): 9.35065	Bending (σ_b): 9.351	0%
		Total: 9.35065	Torsional (σ_w): 29.705	
			Total: 39.0568	76.1%
	1	Bending (σ_b): 9.35065	Bending (σ_b): 9.351	0%
		Total: 9.35065	Torsional (σ_w): 14.042	
			Total: 23.393	60.0%
	2	Bending (τ_b): -.1168265	Bending (τ_b): -.1138	2.6%
		Total: -.1168265	Torsional (τ_t): 0	
			Warping (τ_{ws}): 1.061	
	3	Bending (τ_b): .2984913	Bending (τ_b): .3041	1.8%
		Total: .2984913	Torsional (τ_t): 0	
			Warping (τ_{ws}): .738	
0 in.	0	Bending (σ_b): 6.233767	Bending (σ_b): 6.234	0%
		Total: 6.233767	Torsional (σ_w): -2.238	
			Total: 3.996	35.9%
	1	Bending (σ_b): 6.233767	Bending (σ_b): 6.234	0%
		Total: 6.233767	Torsional (σ_w): -1.058	
			Total: 5.176	16.9%
	2	Bending (τ_b): -.1168265	Bending (τ_b): -.1138	2.6%
		Total: -.1168265	Torsional (τ_t): 4.768	
			Warping (τ_{ws}): -.145	
	3	Bending (τ_b): .2984913	Bending (τ_b): .3041	1.8%
		Total: .2984913	Torsional (τ_t): 3.433	
			Warping (τ_{ws}): -.101	
96 in.	0	Bending (σ_b): 0	Bending (σ_b): 0	0%
		Total: 0	Torsional (σ_w): 0	
			Total: 0	0%
	1	Bending (σ_b): 0	Bending (σ_b): 0	0%
		Total: 0	Torsional (σ_w): 0	
			Total: 0	0%
	2	Bending (τ_b): -.2336530	Bending (τ_b): -.2276	2.6%
		Total: -.2336530	Torsional (τ_t): 3.945	
			Warping (τ_{ws}): .011	
	3	Bending (τ_b): .5969825	Bending (τ_b): .6081	1.8%
		Total: .5969825	Torsional (τ_t): 2.841	
			Warping (τ_{ws}): .008	
192 in.	0	Bending (σ_b): 0	Bending (σ_b): 0	0%
		Total: 0	Torsional (σ_w): 0	
			Total: 0	0%
	1	Bending (σ_b): 0	Bending (σ_b): 0	0%
		Total: 0	Torsional (σ_w): 0	
			Total: 0	0%
	2	Bending (τ_b): -.2336530	Bending (τ_b): -.2276	2.6%
		Total: -.2336530	Torsional (τ_t): 3.945	
			Warping (τ_{ws}): .011	
	3	Bending (τ_b): .5969825	Bending (τ_b): .6081	1.8%
		Total: .5969825	Torsional (τ_t): 2.841	
			Warping (τ_{ws}): .008	
		Total: .5969825	Total: 3.4571	82.7%

Table 5.12 - STRU DL/HAND-CALC. COMPARISON, PROBLEM 12

Chapter Six

CONCLUSIONS

An automated procedure for analyzing plane bending, torsional and warping stresses can be validated through hand-calculated problems that are based on a proven and acceptable analysis method. The Torsional Analysis Case Charts developed by the Bethlehem Steel corporation are an acceptable analysis method, and can therefore be used to verify the stress analysis "TORSION" program.

The comparison tables between the "TORSION" stress output and the hand-calculated results indicates that the percent differences in the torsional and warping stresses calculated by the two analysis methods are slight, and that the "TORSION" program reasonably calculates the various torsional and warping stresses in open steel members.

However, some significant errors were identified in "TORSION's" analysis of plane bending stresses. In four test problems involving members with "fixed-free" boundary conditions, the program calculated plane bending stresses that increased along the member's length from the support to the free end. These discrepancies could be a result of the FORTRAN re-compilation for the program, and warrant further review and validation of "TORSION's" plane bending stress analysis sub-routines.

Other differences in the stress results are attributed to variations in the two analysis methods. In the hand-calculations, the plane bending stresses were calculated at points on the extreme fibers of the member's cross-section, whereas torsional and warping stresses were calculated at points at the flange mid-thickness of the cross-section. When the plane bending and torsional stresses were later combined, this offset in the

points of calculation contributed to some of the difference in the overall flange stresses determined by the two analysis methods.

The program "TORSION" also assumed that all plane bending loads are applied at the shear center of each member. Therefore, the program did not calculate the additional torsional load on a channel's cross-section caused by the eccentricity between the point of load application on the centroid and the shear center. Since these eccentrically-induced torsional loads for the channel sections were included in the hand-calculations, percent differences between the two analysis methods also resulted.

Other errors that resulted in the percent differences illustrated in the comparison tables must be shared by errors in the "TORSION" program and errors in the hand-calculations due to torsional function interpolations that are inherent with using the Torsional Analysis Case Charts.

REFERENCES

AISC "Manual of Steel Construction" (8th Edition), 1980, American Institute of Steel Construction, Inc. Chicago IL

Palacak, Joseph J. and Kahn, Lawrence F., "Analysis of Warping and Torsion in Open Steel Members", 1985

"Steel Design File - Torsional Analysis of Rolled Steel Sections", 1963, Bethlehem Steel Corporation, Bethlehem PA

GTICES Systems Laboratory, School of Civil Engineering, Georgia Institute of Technology, "GTSTRUDL User's Manual", Volume 2, Atlanta GA

APPENDIX A
HAND-CALCULATIONS

<u>Problem No.</u>	<u>Beam Selected</u>	<u>End Conditions</u>
1	W14x109	Fixed-Free
2	W14x159	Pinned-Fixed
3	W12x79	Pinned-Pinned
4	W14x90	Fixed-Fixed
5	W8x15	Fixed-Free
6	W10x49	Fixed-Free
7	W6x15	Fixed-Free
8	W8x67	Fixed-Free
9	C10x20	Fixed-Free
10	C12x30	Fixed-Free
11	C5x9	Fixed-free
12	MC18x42	Fixed-Free

HAND-CALCULATIONS
FOR PROBLEM 1

BEAM SELECTED: W14x109
END CONDITIONS: FIXED-FREE

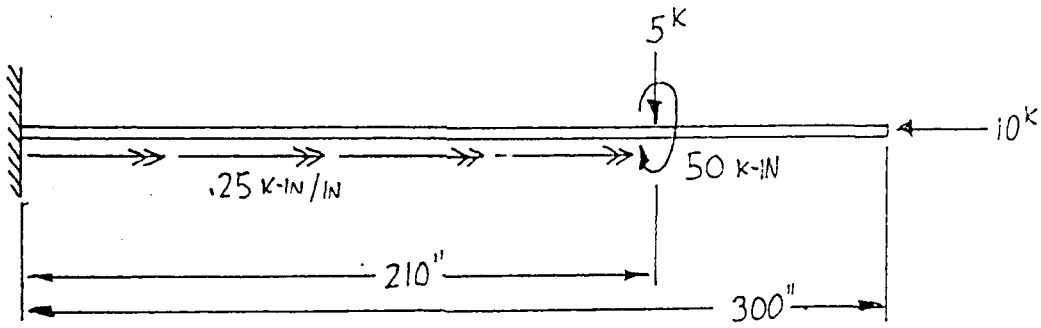

SHEAR & MOMENT DIAGRAMS

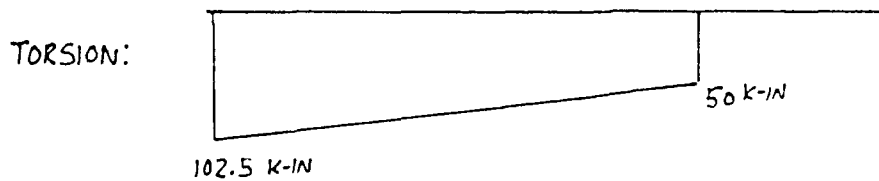
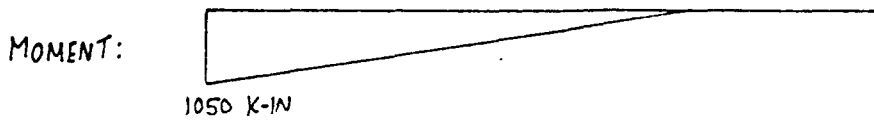
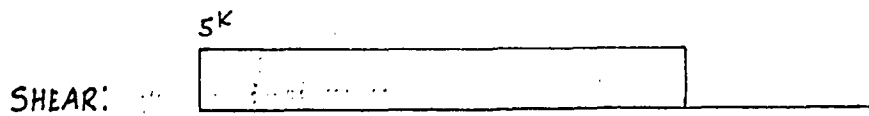
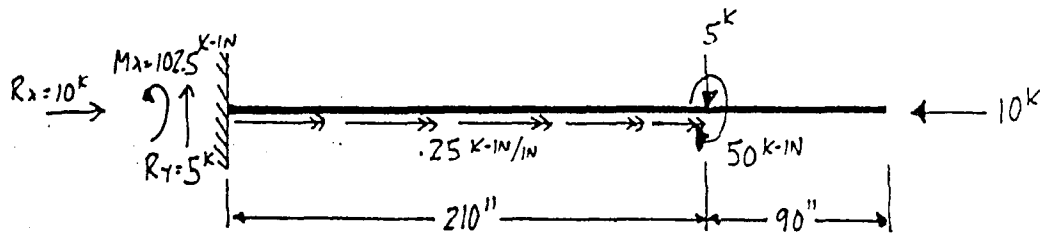

W14x109 DIMENSIONS & PROPERTIES

$A = 32 \text{ in}^2$	$I_x = 1240 \text{ in}^4$	$C_w = 20200 \text{ in}^6$	$Q_F = 41.2 \text{ in}^3$
$d = 14.32 \text{ in}$	$I_y = 447 \text{ in}^4$	$a = 85.8 \text{ in}$	$Q_w = 959 \text{ in}^3$
$t_w = .525 \text{ in}$	$S_x = 173 \text{ in}^3$	$W_{no} = 49.1 \text{ in}^2$	$E = 29000 \text{ ksi}$
$b_f = 14.605 \text{ in}$	$S_y = 61.2 \text{ in}^3$	$S_{w1} = 154 \text{ in}^4$	$G = 11200 \text{ ksi}$
$t_f = .86 \text{ in}$	$J = 7.12 \text{ in}^4$		

PLANE BENDING STRESSES

A. LONGITUDINAL BENDING STRESSES

$$\sigma_B = M_B / S_x$$

$$\text{AT SUPPORT: } \sigma_B = -1050 \text{ k-in} / 173 \text{ in}^3 = -6.0694 \text{ ksi}$$

$$\text{AT .7L (210")}: \sigma_B = 0 \text{ ksi}$$

$$\text{AT FREE END: } \sigma_B = 0 \text{ ksi}$$

B. MAXIMUM WEB SHEAR STRESSES

$$\tau_w = VQ_w / I_{tw}$$

$$\text{AT SUPPORT: } \tau_w = (5^k)(95.9 \text{ in}^3) / (1240 \text{ in}^4)(.525 \text{ in}) = .7366 \text{ ksi}$$

$$\text{AT .7L (210")}: \tau_w = (5^k)(95.9 \text{ in}^3) / (1240 \text{ in}^4)(.525 \text{ in}) = .7366 \text{ ksi}$$

$$\text{AT FREE END: } \tau_w = 0 \text{ ksi}$$

C. MAXIMUM FLANGE SHEAR STRESSES

$$\tau_F = VQ_F / I_{tF}$$

AT SUPPORT: $\tau_F = (5^k)(41.2 \text{ in}^3) / (1240 \text{ in}^4)(.86 \text{ in}) = .1932 \text{ ksi}$

AT .7L (210"): $\tau_F = (5^k)(41.2 \text{ in}^3) / (1240 \text{ in}^4)(.86 \text{ in}) = .1932 \text{ ksi}$

AT FREE END: $\tau_F = 0 \text{ ksi}$

TORSIONAL STRESSES

A. TORSIONAL FUNCTIONS

USE $L/a = 300'' / 85.8'' \approx 3.5$

1) TORSIONAL LOAD 1: $M = 50 \text{ k-in}$ AT 210" (.7L)

USE CASE 9, $\alpha = .7$

AT SUPPORT: $\phi \cdot \left[\frac{GJ}{Ma} \right] = 0$

$\phi'' \cdot \left[\frac{GJ}{M} \cdot 2a \right] = 1.8$

$\phi' \cdot \left[\frac{GJ}{M} \right] = 0$

$\phi''' \cdot \left[\frac{GJa^2}{M} \right] = -1.0$

$\therefore \phi = 0$

$\therefore \phi'' = 6.577 \times 10^{-6}$

$\therefore \phi' = 0$

$\therefore \phi''' = -8.517 \times 10^{-8}$

AT .7L (210"): $\phi \cdot \left[\frac{GJ}{Ma} \right] = 1.16$

$\phi'' \cdot \left[\frac{GJ}{M} \cdot 2a \right] = -.72$

$\phi' \cdot \left[\frac{GJ}{M} \right] = .46$

$\phi''' \cdot \left[\frac{GJa^2}{M} \right] = -.53$

$\therefore \phi = .062405$

$\therefore \phi'' = -2.6308 \times 10^{-6}$

$\therefore \phi' = .0002884$

$\therefore \phi''' = -4.51412 \times 10^{-8}$

$$\begin{aligned} \text{AT FREE END: } \phi \cdot \left[\frac{GJ}{Ma} \right] &= 1.52 \\ \phi'' \cdot \left[\frac{GJ}{m} \cdot 2a \right] &= 0 \\ \phi' \cdot \left[\frac{GJ}{m} \right] &= .28 \\ \phi''' \cdot \left[\frac{GJa^2}{m} \right] &= .28 \end{aligned}$$

$$\begin{aligned} \therefore \phi &= .08177 \\ \therefore \phi'' &= 0 \\ \therefore \phi' &= .000175561 \\ \therefore \phi''' &= 2.384819 \times 10^{-8} \end{aligned}$$

2) TORSIONAL LOAD 2: $m = .25 \text{ K-IN/IN}$ FROM 0" TO 210"

USE CASE 10, $\alpha = .7$

$$\begin{aligned} \text{AT SUPPORT: } \phi \cdot \left[\frac{GJ}{Ma^2} \right] &= 0 \\ \phi'' \cdot \left[\frac{GJ}{m} \right] &= 1.55 \\ \phi' \cdot \left[\frac{GJ}{ma} \right] &= 0 \\ \phi''' \cdot \left[\frac{GJa}{m} \right] &= -2.45 \end{aligned}$$

$$\begin{aligned} \therefore \phi &= 0 \\ \therefore \phi'' &= 4.8593 \times 10^{-6} \\ \therefore \phi' &= 0 \\ \therefore \phi''' &= -8.98343 \times 10^{-8} \end{aligned}$$

$$\begin{aligned} \text{AT .7L (210")}: \phi \cdot \left[\frac{GJ}{Ma^2} \right] &= 1.25 \\ \phi'' \cdot \left[\frac{GJ}{m} \right] &= -.25 \\ \phi' \cdot \left[\frac{GJ}{ma} \right] &= .38 \\ \phi''' \cdot \left[\frac{GJa}{m} \right] &= .38 \end{aligned}$$

$$\begin{aligned} \therefore \phi &= .0288487 \\ \therefore \phi'' &= -7.83758 \times 10^{-7} \\ \therefore \phi' &= .000102214 \\ \therefore \phi''' &= 1.3885 \times 10^{-8} \end{aligned}$$

$$\begin{aligned} \text{AT FREE END: } \phi \cdot \left[\frac{GJ}{Ma^2} \right] &= 1.5 \\ \phi'' \cdot \left[\frac{GJ}{m} \right] &= 0 \\ \phi' \cdot \left[\frac{GJ}{ma} \right] &= .1 \\ \phi''' \cdot \left[\frac{GJa}{m} \right] &= .1 \end{aligned}$$

$$\begin{aligned} \therefore \phi &= .0346185 \\ \therefore \phi'' &= 0 \\ \therefore \phi' &= .000026398 \\ \therefore \phi''' &= 3.65388 \times 10^{-9} \end{aligned}$$

3) SUMMATION OF $\phi, \phi'', \phi', \phi'''$ FOR LOADS 1 AND 2

AT SUPPORT: $\phi = 0$
 $\phi'' = 1.14363 \times 10^{-5}$
 $\phi' = 0$
 $\phi''' = -1.75 \times 10^{-7}$

AT .7L (210"): $\phi = .0912537$
 $\phi'' = -3.41456 \times 10^{-6}$
 $\phi' = .0003906$
 $\phi''' = -3.12564 \times 10^{-8}$

AT FREE END: $\phi = .1163885$
 $\phi'' = 0$
 $\phi' = .000202459$
 $\phi''' = 2.7502 \times 10^{-8}$

B. STRESS CALCULATIONS

1) TORSIONAL SHEAR STRESSES

$$\tau_t = G t \phi'$$

$$t_F = .86''$$

$$t_w = .525''$$

AT SUPPORT: $\tau_{tF} = (11200 \text{ ksi})(.86 \text{ in})(0) = 0 \text{ ksi}$
 $\tau_{tw} = (11200 \text{ ksi})(.525 \text{ in})(0) = 0 \text{ ksi}$

AT .7L (210"): $\tau_{tF} = (11200 \text{ ksi})(.86 \text{ in})(.0003906/\text{in}) = 3.7623 \text{ ksi}$
 $\tau_{tw} = (11200 \text{ ksi})(.525 \text{ in})(.0003906/\text{in}) = 2.29673 \text{ ksi}$

AT FREE END: $\tau_{tf} = (11200 \text{ ksi})(.861 \text{ in})(.000202459) = 1.95009 \text{ ksi}$
 $\tau_{tw} = (11200 \text{ ksi})(.525 \text{ in})(.000202459) = 1.19046 \text{ ksi}$

2) WARPING NORMAL STRESSES

MAXIMUM AT FLANGE TIPS!

$$\sigma_{ws} = E \omega_{no} \phi''$$

$$\omega_{no} = 49.1 \text{ in}^2$$

AT SUPPORT: $\sigma_{ws} = (29000 \text{ ksi})(49.1 \text{ in}^2)(1.14363 \times 10^{-5}) = 16.28415 \text{ ksi}$

AT .7L (210"): $\sigma_{ws} = (29000 \text{ ksi})(49.1 \text{ in}^2)(-3.41456 \times 10^{-6}) = -4.86199 \text{ ksi}$

AT FREE END: $\sigma_{ws} = (29000 \text{ ksi})(49.1 \text{ in}^2)(0) = 0 \text{ ksi}$

3) WARPING SHEAR STRESSES

MAXIMUM AT FLANGE CENTERS!

$$\tau_{ws} = -\frac{E S_{ws}}{t} \phi'''$$

$$S_{ws} = 154 \text{ in}^4, t = .86 \text{ in}$$

AT SUPPORT: $\tau_{ws} = \frac{(-29000 \text{ ksi})(154 \text{ in}^4)}{(.86 \text{ in})} (-1.75 \times 10^{-7}) = .9088 \text{ ksi}$

AT .7L (210"): $\tau_{ws} = \frac{(-29000 \text{ ksi})(154 \text{ in}^4)}{(.86 \text{ in})} (-3.12564 \times 10^{-8}) = .1624 \text{ ksi}$

AT FREE END: $\tau_{ws} = \frac{(-29000 \text{ ksi})(154 \text{ in}^4)}{(.86 \text{ in})} (2.7502 \times 10^{-8}) = -.1428 \text{ ksi}$

HAND-CALCULATIONS
FOR PROBLEM 2

BEAM SELECTED: W14 x 159
END CONDITIONS: PINNED - FIXED

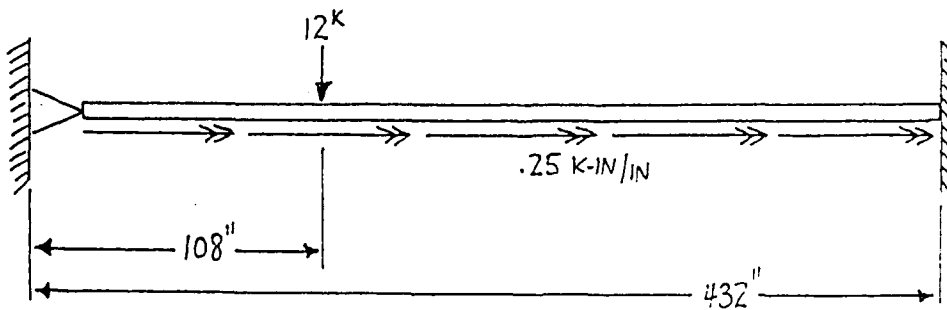

SHEAR & MOMENT DIAGRAMS

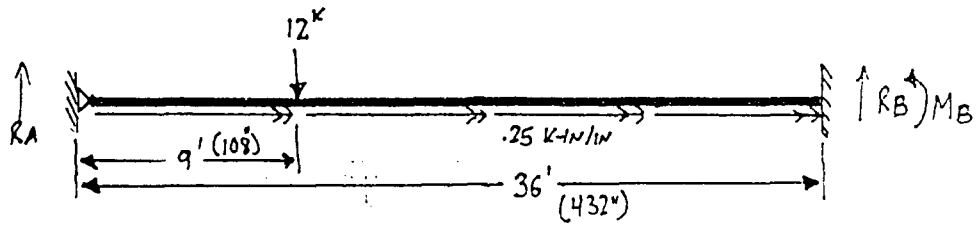

$$R_A = \frac{Pb^2}{2l^3} (a+2l) = \frac{12(27)^2}{2(36)^3} (9+2 \cdot 36) = 7.59 \text{ k}$$

$$R_B = \frac{Pa}{2l^3} (3l^2 - a^2) = \frac{12(9)}{2(36)^3} (3(36)^2 - (9)^2) = 4.41 \text{ k}$$

$$M_B = \frac{Pab}{2l^2} (a+l) = \frac{12(9)(27)}{2(36)^2} (9+36) = 50.625 \text{ k-ft} = 607.5 \text{ k-in}$$

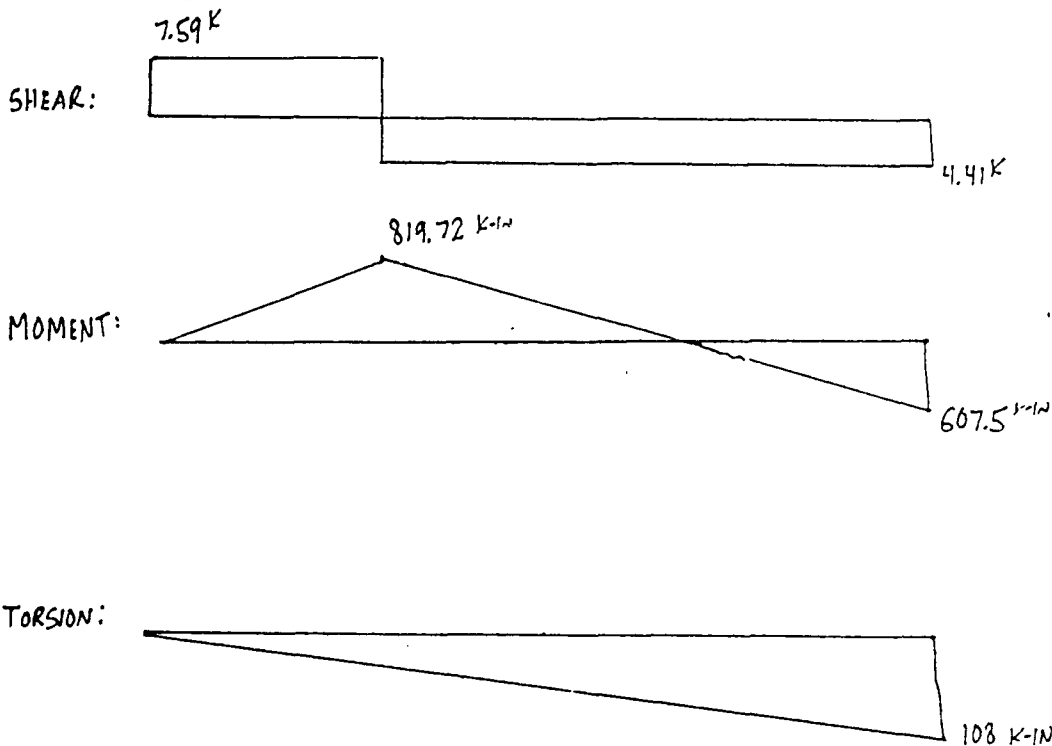

W14x159 DIMENSIONS & PROPERTIES

$$\begin{array}{llll} A = 46.7 \text{ in}^2 & I_x = 1900 \text{ in}^4 & C_w = 35600 \text{ in}^6 & Q_F = 61.3 \text{ in}^3 \\ d = 14.98 \text{ in} & I_y = 748 \text{ in}^4 & a = 68.3 \text{ in} & Q_w = 143 \text{ in}^3 \\ b_f = 15.565 \text{ in} & S_x = 254 \text{ in}^3 & W_{no} = 53.7 \text{ in}^2 & E = 29000 \text{ ksi} \\ t_f = 1.19 \text{ in} & S_y = 96.2 \text{ in}^3 & S_w = 248 \text{ in}^4 & G = 11200 \text{ ksi} \\ t_w = .745 \text{ in} & J = 19.8 \text{ in}^4 & & \end{array}$$

PLANE BENDING STRESSES

A. LONGITUDINAL BENDING STRESSES

$$\sigma_B = M/S_x$$

$$\text{AT PINNED SUPPORT: } \sigma_B = 0 \text{ ksi}$$

$$\text{AT POINT LOAD (108")}: \sigma_B = 819.72 \text{ k-in} / 254 \text{ in}^3 = 3.227 \text{ ksi}$$

$$\text{AT FIXED SUPPORT: } \sigma_B = -607.5 \text{ k-in} / 254 \text{ in}^3 = -2.392 \text{ ksi}$$

B. MAXIMUM WEB SHEAR STRESSES

$$\tau_w = \frac{VQ_w}{I t_w}$$

$$\text{AT PINNED SUPPORT: } \tau_w = \frac{(-7.59 \text{ k})(143 \text{ in}^3)}{(1900 \text{ in}^4)(.745 \text{ in})} = -.767 \text{ ksi}$$

$$\text{AT POINT LOAD (108")}: \tau_w = \frac{(-7.59 \text{ k})(143 \text{ in}^3)}{(1900 \text{ in}^4)(.745 \text{ in})} = -.767 \text{ ksi}$$

$$\text{AT FIXED SUPPORT: } \tau_w = \frac{(4.41 \text{ k})(143 \text{ in}^3)}{(1900 \text{ in}^4)(.745 \text{ in})} = .446 \text{ ksi}$$

C. MAXIMUM FLANGE SHEAR STRESSES

$$\tau_F = VQ_F / I_{tF}$$

AT PINNED SUPPORT: $\tau_F = (-7.59 \text{ K})(61.3 \text{ in}^3) / (1900 \text{ in}^4)(1.19 \text{ in}) = -206 \text{ ksi}$

AT POINT LOAD (108"): $\tau_F = (-7.59 \text{ K})(61.3 \text{ in}^3) / (1900 \text{ in}^4)(1.19 \text{ in}) = -206 \text{ ksi}$

AT FIXED SUPPORT: $\tau_F = (4.41 \text{ K})(61.3 \text{ in}^3) / (1900 \text{ in}^4)(1.19 \text{ in}) = 120 \text{ ksi}$

TORSIONAL STRESSES

A. TORSIONAL FUNCTIONS

USE $L/a = 432'' / 68.3'' = 6.33$

TORSIONAL LOAD 1: $m = -.25 \text{ K-IN/IN}$ FROM 0" TO 432"
USE CASE 12

AT PINNED SUPPORT:

$\phi \cdot \left[\frac{GJ}{m} \cdot \frac{1}{a^2} \right] = 0$	$\therefore \phi = 0$
$\phi'' \cdot \left[\frac{GJ}{m} \right] = 0$	$\therefore \phi'' = 0$
$\phi' \cdot \left[\frac{GJ}{m} \cdot \frac{2}{a} \right] = -3.2$	$\therefore \phi' = 1.23196 \times 10^{-4}$
$\phi''' \cdot \left[\frac{GJa}{m} \right] = 1.0$	$\therefore \phi''' = -1.650578 \times 10^{-8}$

AT POINT LOAD (108"):

$\phi \cdot \left[\frac{GJ}{m} \cdot \frac{1}{a^2} \right] = 2.025$	$\therefore \phi = .010649$
$\phi'' \cdot \left[\frac{GJ}{m} \right] = -.75$	$\therefore \phi'' = 8.45509 \times 10^{-7}$
$\phi' \cdot \left[\frac{GJ}{m} \cdot \frac{2}{a} \right] = -1.8$	$\therefore \phi' = 6.92979 \times 10^{-5}$
$\phi''' \cdot \left[\frac{GJa}{m} \right] = .20$	$\therefore \phi''' = -3.30116 \times 10^{-9}$

$$\begin{aligned}
 \text{AT FIXED SUPPORT: } \phi \cdot \left[\frac{6J}{3I} \cdot \frac{1}{a^2} \right] &= 0 & \therefore \phi &= 0 \\
 \phi'' \cdot \left[\frac{6J}{3I} \right] &= 2.375 & \therefore \phi'' &= 2.67744 \times 10^{-6} \\
 \phi' \cdot \left[\frac{6J}{3I} \cdot \frac{2}{a} \right] &= 0 & \therefore \phi' &= 0 \\
 \phi''' \cdot \left[\frac{6J}{3I} \right] &= -3.4 & \therefore \phi''' &= 5.61197 \times 10^{-8}
 \end{aligned}$$

B. STRESS CALCULATIONS

1) TORSIONAL SHEAR STRESSES

$$\begin{aligned}
 t_F &= 1.19 \text{ in} \\
 t_w &= .745 \text{ in}
 \end{aligned}$$

$$\tau_t = G t \phi'$$

$$\begin{aligned}
 \text{AT PINNED SUPPORT: } \tau_{tw} &= (11200 \text{ ksi})(.745 \text{ in})(1.23196 \times 10^{-4}) = 1.028 \text{ ksi} \\
 \tau_{tF} &= (11200 \text{ ksi})(1.19 \text{ in})(1.23196 \times 10^{-4}) = 1.642 \text{ ksi}
 \end{aligned}$$

$$\begin{aligned}
 \text{AT POINT LOAD (108")}: \tau_{tw} &= (11200 \text{ ksi})(.745 \text{ in})(6.92979 \times 10^{-5}) = .578 \text{ ksi} \\
 \tau_{tF} &= (11200 \text{ ksi})(1.19 \text{ in})(6.92979 \times 10^{-5}) = .924 \text{ ksi}
 \end{aligned}$$

$$\begin{aligned}
 \text{AT FIXED SUPPORT: } \tau_{tw} &= (11200 \text{ ksi})(.745 \text{ in})(0) = 0 \text{ ksi} \\
 \tau_{tF} &= (11200 \text{ ksi})(1.19 \text{ in})(0) = 0 \text{ ksi}
 \end{aligned}$$

2) WARPING NORMAL STRESSES

$$\begin{aligned}
 &\text{MAXIMUM AT FLANGE TIPS!} \\
 W_{no} &= 53.7 \text{ in}^2
 \end{aligned}$$

$$\sigma_{ws} = E W_{no} \phi''$$

$$\begin{aligned}
 \text{AT PINNED SUPPORT: } \sigma_{ws} &= (29000 \text{ ksi})(53.7 \text{ in}^2)(0) = 0 \text{ ksi} \\
 \text{AT POINT LOAD (108")}: \sigma_{ws} &= (29000 \text{ ksi})(53.7 \text{ in}^2)(8.45509 \times 10^{-7}) = 1.317 \text{ ksi} \\
 \text{AT FIXED SUPPORT: } \sigma_{ws} &= (29000 \text{ ksi})(53.7 \text{ in}^2)(-2.67744 \times 10^{-6}) = -4.17 \text{ ksi}
 \end{aligned}$$

3) WARPING SHEAR STRESSES

$$\tau_{ws} = -\frac{E S_w}{t} \phi'''$$

MAXIMUM AT FLANGE CENTERS!

$$S_w = 248 \text{ in}^4, t_f = 1.19 \text{ in}$$

$$\text{AT PINNED SUPPORT: } \tau_{ws} = \frac{-(29000 \text{ ksi})(248 \text{ in}^4)}{(1.19 \text{ in})} (-1.650578 \times 10^{-2}) = .100 \text{ ksi}$$

$$\text{AT POINT LOAD (108")}: \tau_{ws} = \frac{-(29000 \text{ ksi})(248 \text{ in}^4)}{(1.19 \text{ in})} (-3.30116 \times 10^{-9}) = .020 \text{ ksi}$$

$$\text{AT FIXED SUPPORT: } \tau_{ws} = \frac{-(29000 \text{ ksi})(248 \text{ in}^4)}{(1.19 \text{ in})} (5.61197 \times 10^{-8}) = -.339 \text{ ksi}$$

HAND-CALCULATIONS
FOR PROBLEM 3

BEAM SELECTED: W12x79
END CONDITIONS: PINNED-PINNED

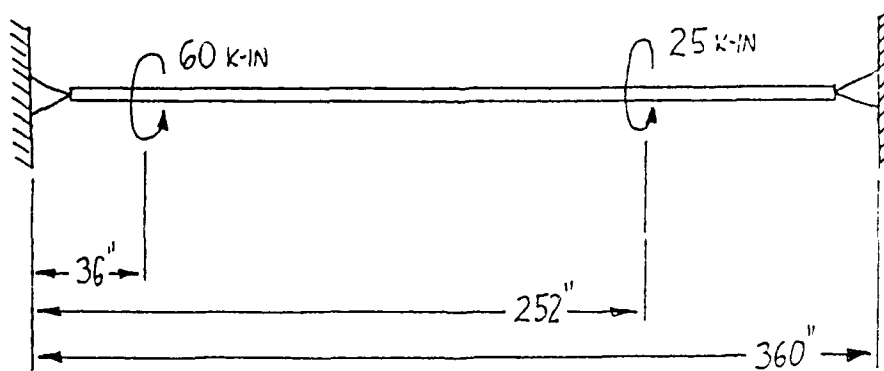

SHEAR & MOMENT DIAGRAMS

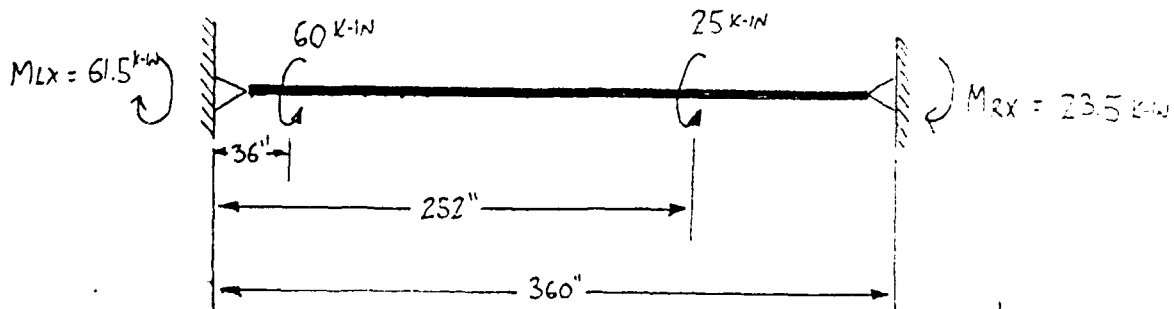

NO PLANE BENDING LOADS OR STRESSES

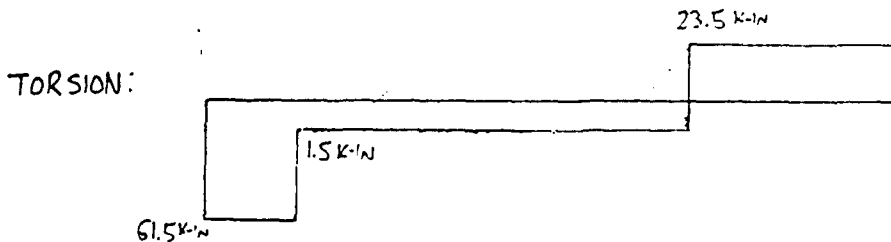

W12x79 DIMENSIONS & PROPERTIES

$A = 23.2 \text{ in}^2$	$I_x = 662 \text{ in}^4$	$C_w = 7330 \text{ in}^6$	$Q_F = 25.3 \text{ in}^3$
$d = 12.38 \text{ in}$	$I_y = 216 \text{ in}^4$	$a = 70.3 \text{ in}$	$Q_w = 59.5 \text{ in}^3$
$b_f = 12.08 \text{ in}$	$S_x = 107 \text{ in}^3$	$W_{ho} = 35.2 \text{ in}^2$	$E = 29000 \text{ ksi}$
$t_w = .47 \text{ in}$	$S_y = 35.8 \text{ in}^3$	$S_w = 78.1 \text{ in}^4$	$G = 11200 \text{ ksi}$
$t_f = .735 \text{ in}$	$J = 3.84 \text{ in}^4$		

TORSIONAL STRESSES

A. TORSIONAL FUNCTIONS

USE $L/a = 360"/70.3" = 5.12$

D) TORSIONAL LOAD 1: $M = 60 \text{ K-IN}$ AT .1L (36")

USE CASE 3, $\alpha = .1$

$$\begin{aligned} \text{AT LEFT SUPPORT: } \phi \cdot \left[\frac{GJ}{M} \cdot \frac{5}{L} \right] &= 0 & \therefore \phi &= 0 \\ \phi'' \cdot \left[\frac{GJa}{M} \right] &= 0 & \therefore \phi'' &= 0 \\ \phi' \cdot \left[\frac{GJ}{M} \right] &= .29 & \therefore \phi' &= 4.04576 \times 10^{-4} \\ \phi''' \cdot \left[\frac{GJa^2}{M} \right] &= -.61 & \therefore \phi''' &= -1.72195 \times 10^{-7} \end{aligned}$$

$$\begin{aligned} \text{AT .1L (36") : } \phi \cdot \left[\frac{GJ}{M} \cdot \frac{5}{L} \right] &= .135 & \therefore \phi &= .013560 \\ \phi'' \cdot \left[\frac{GJa}{M} \right] &= -.315 & \therefore \phi'' &= -6.25111 \times 10^{-6} \\ \phi' \cdot \left[\frac{GJ}{M} \right] &= .21 & \therefore \phi' &= 2.92969 \times 10^{-4} \\ \phi''' \cdot \left[\frac{GJa^2}{M} \right] &= -.09 & \therefore \phi''' &= -1.94773 \times 10^{-7} \end{aligned}$$

$$\begin{aligned} \text{AT .7L (252") : } \phi \cdot \left[\frac{GJ}{M} \cdot \frac{5}{L} \right] &= .13 & \therefore \phi &= .013058 \\ \phi'' \cdot \left[\frac{GJa}{M} \right] &= -.015 & \therefore \phi'' &= -2.97672 \times 10^{-7} \\ \phi' \cdot \left[\frac{GJ}{M} \right] &= -.08 & \therefore \phi' &= -1.11607 \times 10^{-4} \\ \phi''' \cdot \left[\frac{GJa^2}{M} \right] &= .02 & \therefore \phi''' &= 5.64575 \times 10^{-7} \end{aligned}$$

$$\begin{aligned} \text{AT RIGHT SUPPORT: } \phi \cdot \left[\frac{GJ}{M} \cdot \frac{5}{L} \right] &= 0 & \therefore \phi &= 0 \\ \phi'' \cdot \left[\frac{GJa}{M} \right] &= 0 & \therefore \phi'' &= 0 \\ \phi' \cdot \left[\frac{GJ}{M} \right] &= -.09 & \therefore \phi' &= -1.25558 \times 10^{-4} \\ \phi''' \cdot \left[\frac{GJa^2}{M} \right] &= .01 & \therefore \phi''' &= 2.82287 \times 10^{-7} \end{aligned}$$

2) TORSIONAL LOAD 2 : $M = 25 \text{ k-in}$ AT $.7L$ (252")

USE CASE 3, $\alpha = .3$ FROM THE RIGHT!

AT LEFT SUPPORT:

$$\begin{aligned} \phi \cdot \left[\frac{GJ}{ML} \right] &= 0 & \therefore \phi &= 0 \\ \phi'' \cdot \left[\frac{GJa}{M} \right] &= 0 & \therefore \phi'' &= 0 \\ \phi' \cdot \left[\frac{GJ}{M} \right] &= .27 & \therefore \phi' &= 1.56948 \times 10^{-4} \\ \phi''' \cdot \left[\frac{GJa^2}{M} \right] &= -.03 & \therefore \phi''' &= -3.52859 \times 10^{-9} \end{aligned}$$

AT .1L (36"):

$$\begin{aligned} \phi \cdot \left[\frac{GJ}{ML} \right] &= .025 & \therefore \phi &= .005232 \\ \phi'' \cdot \left[\frac{GJa}{M} \right] &= .01 & \therefore \phi'' &= 8.26867 \times 10^{-8} \\ \phi' \cdot \left[\frac{GJ}{M} \right] &= .27 & \therefore \phi' &= 1.56948 \times 10^{-4} \\ \phi''' \cdot \left[\frac{GJa^2}{M} \right] &= -.03 & \therefore \phi''' &= -3.52859 \times 10^{-9} \end{aligned}$$

AT .7L (252"):

$$\begin{aligned} \phi \cdot \left[\frac{GJ}{ML} \right] &= .115 & \therefore \phi &= .024065 \\ \phi'' \cdot \left[\frac{GJa}{M} \right] &= -.47 & \therefore \phi'' &= -3.88627 \times 10^{-6} \\ \phi' \cdot \left[\frac{GJ}{M} \right] &= -.18 & \therefore \phi' &= -1.04632 \times 10^{-4} \\ \phi''' \cdot \left[\frac{GJa^2}{M} \right] &= -.47 & \therefore \phi''' &= -5.52813 \times 10^{-8} \end{aligned}$$

AT RIGHT SUPPORT:

$$\begin{aligned} \phi \cdot \left[\frac{GJ}{ML} \right] &= 0 & \therefore \phi &= 0 \\ \phi'' \cdot \left[\frac{GJa}{M} \right] &= 0 & \therefore \phi'' &= 0 \\ \phi' \cdot \left[\frac{GJ}{M} \right] &= -.47 & \therefore \phi' &= -2.73205 \times 10^{-4} \\ \phi''' \cdot \left[\frac{GJa^2}{M} \right] &= .23 & \therefore \phi''' &= 2.70525 \times 10^{-8} \end{aligned}$$

3) SUMMATION OF $\phi, \phi'', \phi', \phi'''$ FOR LOADS 1 AND 2

AT LEFT SUPPORT: $\phi = 0$
 $\phi'' = 0$
 $\phi' = 5.61524 \times 10^{-4}$
 $\phi''' = -1.75724 \times 10^{-7}$

AT .1L (36"):
 $\phi = .018792$
 $\phi'' = -6.16842 \times 10^{-6}$
 $\phi' = 4.49917 \times 10^{-4}$
 $\phi''' = -1.98307 \times 10^{-7}$

AT .7L (252"):
 $\phi = .037123$
 $\phi'' = -4.18394 \times 10^{-6}$
 $\phi' = -2.1624 \times 10^{-4}$
 $\phi''' = -4.9636 \times 10^{-8}$

AT RIGHT SUPPORT:
 $\phi = 0$
 $\phi'' = 0$
 $\phi' = -3.98763 \times 10^{-4}$
 $\phi''' = 2.98754 \times 10^{-8}$

B. STRESS CALCULATIONS

1) TORSIONAL SHEAR STRESSES

$$\tau_t = G \pm \phi'$$

$$t_w = .47 \text{ in}$$

$$t_f = .735 \text{ in}$$

$$\text{AT LEFT SUPPORT: } \tau_{tw} = (11200 \text{ ksi})(.47 \text{ in})(5.61524 \times 10^{-4}) = 2.96 \text{ ksi}$$

$$\tau_{tF} = (11200 \text{ ksi})(.735 \text{ in})(5.61524 \times 10^{-4}) = 4.62 \text{ ksi}$$

$$\text{AT .1L (36")}: \tau_{tw} = (11200 \text{ ksi})(.47 \text{ in})(4.49917 \times 10^{-4}) = 2.37 \text{ ksi}$$

$$\tau_{tF} = (11200 \text{ ksi})(.735 \text{ in})(4.49917 \times 10^{-4}) = 3.70 \text{ ksi}$$

$$\text{AT .7L (252")}: \tau_{tw} = (11200 \text{ ksi})(.47 \text{ in})(-2.1624 \times 10^{-4}) = -1.14 \text{ ksi}$$

$$\tau_{tF} = (11200 \text{ ksi})(.735 \text{ in})(-2.1624 \times 10^{-4}) = -1.78 \text{ ksi}$$

$$\text{AT RIGHT SUPPORT: } \tau_{tw} = (11200 \text{ ksi})(.47 \text{ in})(-3.98763 \times 10^{-4}) = -2.10 \text{ ksi}$$

$$\tau_{tF} = (11200 \text{ ksi})(.735 \text{ in})(-3.98763 \times 10^{-4}) = -3.28 \text{ ksi}$$

2) WARPING NORMAL STRESSES

MAXIMUM AT FLANGE TIPS!

$$\sigma_w = E W_n \phi''$$

$$W_n = 35.2 \text{ in}^2$$

$$\text{AT LEFT SUPPORT: } \sigma_w = (29000 \text{ ksi})(35.2 \text{ in}^2)(0) = 0 \text{ ksi}$$

$$\text{AT .1L (36")}: \sigma_w = (29000 \text{ ksi})(35.2 \text{ in}^2)(-6.16842 \times 10^{-6}) = -6.297 \text{ ksi}$$

$$\text{AT .7L (252")}: \sigma_w = (29000 \text{ ksi})(35.2 \text{ in}^2)(-4.18394 \times 10^{-6}) = -4.271 \text{ ksi}$$

$$\text{AT RIGHT SUPPORT: } \sigma_w = (29000 \text{ ksi})(35.2 \text{ in}^2)(0) = 0 \text{ ksi}$$

3) WARPING SHEAR STRESSES

$$\tau_w = -\frac{E S_w}{L F} \phi'''$$

MAXIMUM AT FLANGE CENTERS!

$$L F = .735 \text{ in}, S_w = 78.1 \text{ in}^4$$

$$\text{AT LEFT SUPPORT: } \tau_w = \frac{-(29000 \text{ ksi})(78.1 \text{ in}^4)}{(.735 \text{ in})} (-1.75724 \times 10^{-7}) = .541 \text{ ksi}$$

$$\text{AT .1L (36")}: \tau_w = \frac{-(29000 \text{ ksi})(78.1 \text{ in}^4)}{(.735 \text{ in})} (-1.98307 \times 10^{-7}) = .611 \text{ ksi}$$

$$\text{AT .7L (252")}: \tau_w = \frac{-(29000 \text{ ksi})(78.1 \text{ in}^4)}{(.735 \text{ in})} (-4.9636 \times 10^{-8}) = .206 \text{ ksi}$$

$$\text{AT RIGHT SUPPORT: } \tau_w = \frac{-(29000 \text{ ksi})(78.1 \text{ in}^4)}{(.735 \text{ in})} (2.98754 \times 10^{-8}) = -.092 \text{ ksi}$$

HAND - CALCULATIONS
FOR PROBLEM 4

BEAM SELECTED: W14 x 90
END CONDITIONS: FIXED - FIXED

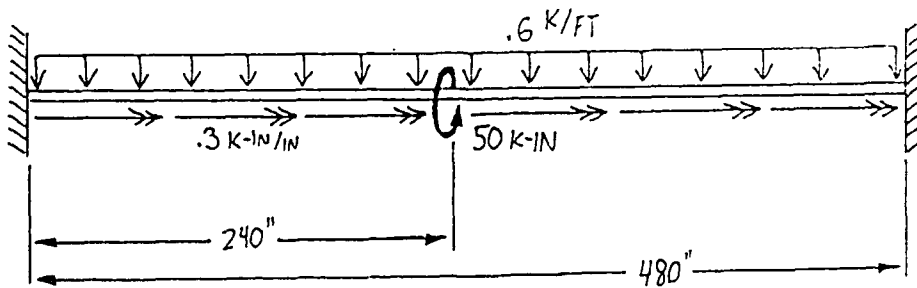

SHEAR & MOMENT DIAGRAMS

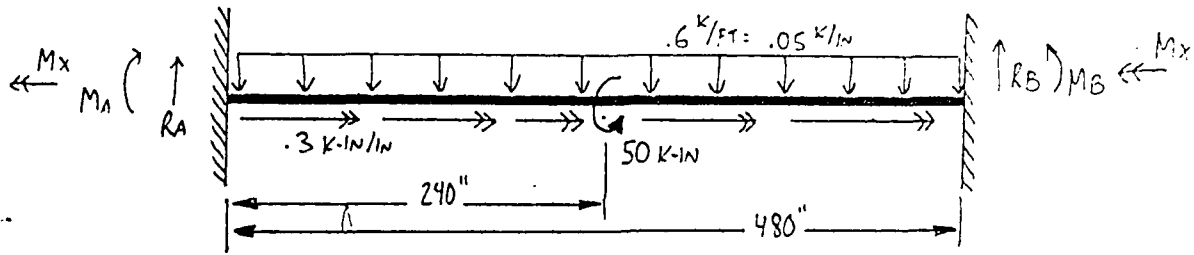

$$R_A = R_B = 12^k$$

$$M_A = M_B = \frac{1}{12} (0.05 \text{ k/in}) (480 \text{ in})^2 = -960 \text{ k-in}$$

$$M_{POS} = \frac{1}{24} (0.05 \text{ k/in}) (480 \text{ in})^2 = 480 \text{ k-in}$$

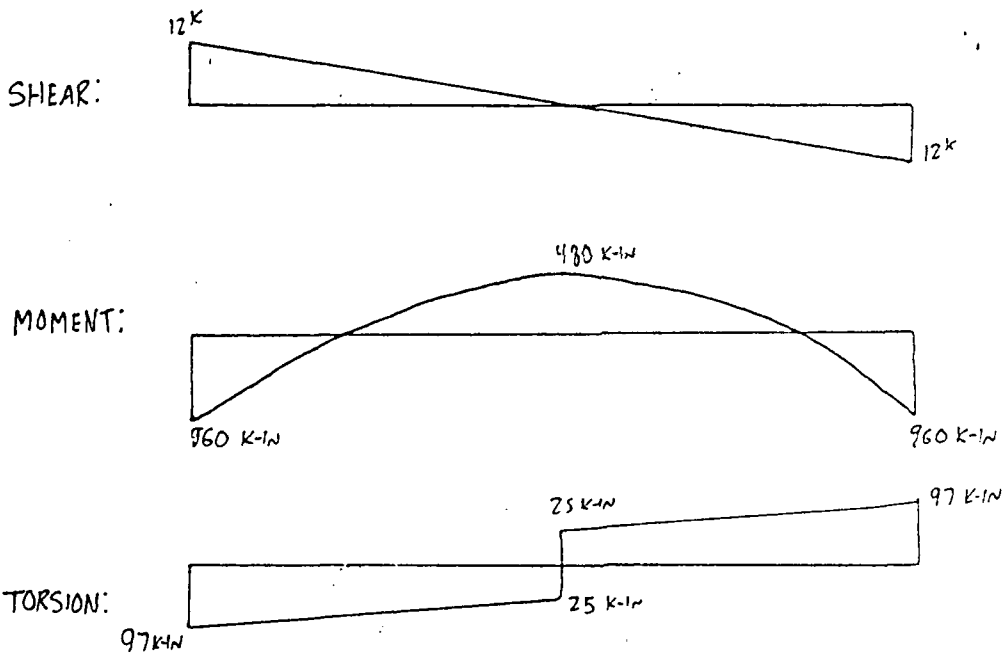

W14x90 DIMENSIONS & PROPERTIES

$A = 26.5 \text{ in}^2$	$t_f = .71 \text{ in}$	$S_y = 49.9 \text{ in}^3$	$W_{no} = 48.3 \text{ in}^2$	$E = 29000 \text{ ksi}$
$d = 14.02 \text{ in}$	$I_x = 999 \text{ in}^4$	$J = 4.06 \text{ in}^4$	$S_w = 125 \text{ in}^4$	$G = 11200 \text{ ksi}$
$b_f = 14.52 \text{ in}$	$I_y = 362 \text{ in}^4$	$C_w = 16000 \text{ in}^6$	$Q_f = 33.7 \text{ in}^3$	
$t_w = .44 \text{ in}$	$S_x = 143 \text{ in}^3$	$a = 101 \text{ in}$	$Q_w = 78.3 \text{ in}^3$	

PLANE BENDING STRESSES

A. LONGITUDINAL BENDING STRESSES

$$\sigma_B = M_B / S_x$$

AT LEFT & RIGHT SUPPORTS: $\sigma_B = -960 \text{ k-in} / 143 \text{ in}^3 = -6.7133 \text{ ksi}$

AT .5L (240"): $\sigma_B = 480 \text{ k-in} / 143 \text{ in}^3 = 3.3566 \text{ ksi}$

B. MAXIMUM WEB SHEAR STRESSES

$$\tau_w = VQ_w / I_t w$$

AT LEFT & RIGHT SUPPORTS: $\tau_w = (12 \text{ k})(78.3 \text{ in}^2) / (999 \text{ in}^4)(.44 \text{ in}) = 2.1376 \text{ ksi}$

AT .5L (240"): $\tau_w = 0 \text{ ksi}$

C. MAXIMUM FLANGE SHEAR STRESSES

$$\tau_F = VQ_F / I_t F$$

AT LEFT & RIGHT SUPPORTS: $\tau_F = (12 \text{ k})(33.7 \text{ in}^3) / (999 \text{ in}^4)(.71 \text{ in}) = .5701 \text{ ksi}$

AT .5L (240"): $\tau_F = 0 \text{ ksi}$

TORSIONAL STRESSES

A. TORSIONAL FUNCTIONS

$$\text{USE } L/a = 480''/101'' = 4.75$$

1) TORSIONAL LOAD 1: $M = 50 \text{ K-IN AT } 240'' (.5L)$

USE CASE 6, $\alpha = .5$

AT LEFT & RIGHT SUPPORTS:

$$\phi \cdot \left[\frac{GJ}{Ma} \right] = 0$$

$$\therefore \phi = 0$$

$$\phi'' \cdot \left[\frac{GJa}{M} \right] = .41$$

$$\therefore \phi'' = 4.46363 \times 10^{-6}$$

$$\phi' \cdot \left[\frac{GJ}{M} \right] = 0$$

$$\therefore \phi' = 0$$

$$\phi''' \cdot \left[\frac{GJa^2}{M} \right] = \mp .5$$

$$\therefore \phi''' = \mp 5.38956 \times 10^{-8}$$

AT .5L (240''):

$$\phi \cdot \left[\frac{GJ}{Ma} \right] = .36$$

$$\therefore \phi = .039981$$

$$\phi'' \cdot \left[\frac{GJa}{M} \right] = -.41$$

$$\therefore \phi'' = -4.46363 \times 10^{-6}$$

$$\phi' \cdot \left[\frac{GJ}{M} \right] = 0$$

$$\therefore \phi' = 0$$

$$\phi''' \cdot \left[\frac{GJa^2}{M} \right] = \mp .5$$

$$\therefore \phi''' = \mp 5.38956 \times 10^{-8}$$

2) TORSIONAL LOAD 2: $m = .3 \text{ K-IN/IN FROM } 0'' \text{ TO } 480''$

USE CASE 7

AT LEFT & RIGHT SUPPORTS:

$$\phi \cdot \left[\frac{G}{3EI} \cdot \frac{2}{aL} \right] = 0$$

$$\therefore \phi = 0$$

$$\phi'' \cdot \left[\frac{G}{3EI} \cdot \frac{2a}{L} \right] = .58$$

$$\therefore \phi'' = 9.09275 \times 10^{-6}$$

$$\phi' \cdot \left[\frac{G}{3EI} \cdot \frac{2}{L} \right] = 0$$

$$\therefore \phi' = 0$$

$$\phi''' \cdot \left[\frac{G}{3EI} \cdot \frac{2a^2}{L} \right] = \mp 1.00$$

$$\therefore \phi''' = \mp 1.55219 \times 10^{-7}$$

AT .5L (240"):

$$\phi \cdot \left[\frac{G}{3EI} \cdot \frac{2}{aL} \right] = .36$$

$$\therefore \phi = .057572$$

$$\phi'' \cdot \left[\frac{G}{3EI} \cdot \frac{2a}{L} \right] = -.23$$

$$\therefore \phi'' = -3.60574 \times 10^{-6}$$

$$\phi' \cdot \left[\frac{G}{3EI} \cdot \frac{2}{L} \right] = 0$$

$$\therefore \phi' = 0$$

$$\phi''' \cdot \left[\frac{G}{3EI} \cdot \frac{2a^2}{L} \right] = 0$$

$$\therefore \phi''' = 0$$

3) SUMMATION OF $\phi, \phi'', \phi', \phi'''$ FOR LOADS 1 AND 2

AT LEFT & RIGHT SUPPORTS:

$$\phi = 0$$

$$\phi'' = 1.35564 \times 10^{-5}$$

$$\phi' = 0$$

$$\phi''' = \mp 2.091146 \times 10^{-7}$$

AT .5L (240"):

$$\phi = .097553$$

$$\phi'' = -8.06937 \times 10^{-6}$$

$$\phi' = 0$$

$$\phi''' = \mp 5.38956 \times 10^{-8}$$

B. STRESS CALCULATIONS

1) TORSIONAL SHEAR STRESSES

$$\tau_t = G t \phi'$$

$$t_w = .44 \text{ IN}$$

$$t_f = .71 \text{ IN}$$

AT LEFT & RIGHT SUPPORTS:

$$\tau_{tw} = (11200 \text{ KSI})(.44 \text{ IN})(0) = 0 \text{ KSI}$$

$$\tau_{tf} = (11200 \text{ KSI})(.71 \text{ IN})(0) = 0 \text{ KSI}$$

AT .5L (240"):

$$\tau_{tw} = (11200 \text{ KSI})(.44 \text{ IN})(0) = 0 \text{ KSI}$$

$$\tau_{tf} = (11200 \text{ KSI})(.71 \text{ IN})(0) = 0 \text{ KSI}$$

2) WARPING NORMAL STRESSES

$$\sigma_{ws} = E W_{ns} \phi''$$

$$W_{ns} = 48.3 \text{ in}^2$$

AT LEFT & RIGHT SUPPORTS:

$$\sigma_{ws} = (29000 \text{ KSI})(48.3 \text{ in}^2)(1.35564 \times 10^{-5}) = 18.99 \text{ KSI}$$

AT .5L (240"):

$$\sigma_{ws} = (29000 \text{ KSI})(48.3 \text{ in}^2)(-8.06937 \times 10^{-6}) = -11.30 \text{ KSI}$$

3) WARPING SHEAR STRESSES

$$\tau_{ws} = -\frac{E S_w}{t} \phi'''$$

MAXIMUM AT FLANGE CENTERS!

$$S_w = 125 \text{ in}^4, t_f = .71 \text{ in.}$$

AT LEFT & RIGHT SUPPORTS:

$$\tau_{ws} = \frac{-(29000 \text{ ksi})(125 \text{ in}^4)}{(.71 \text{ in})} (\mp 2.091146 \times 10^{-7}) = \mp 1.07 \text{ ksi}$$

AT .5L (240"):

$$\tau_{ws} = \frac{-(29000 \text{ ksi})(125 \text{ in}^4)}{(.71 \text{ in})} (\mp 5.38956 \times 10^{-8}) = \mp .28 \text{ ksi}$$

HAND-CALCULATIONS
FOR PROBLEM 5

BEAM SELECTED: W8x15
END CONDITIONS: FIXED-FREE

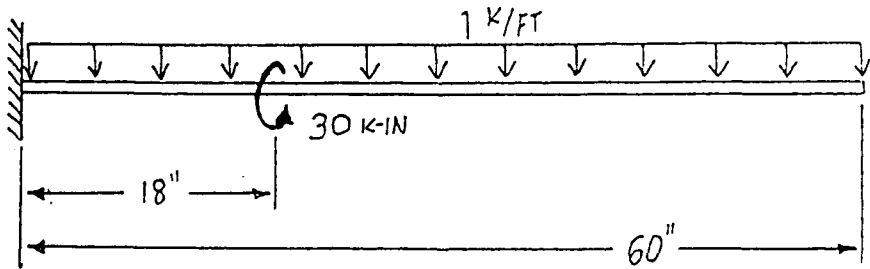

SHEAR & MOMENT DIAGRAMS

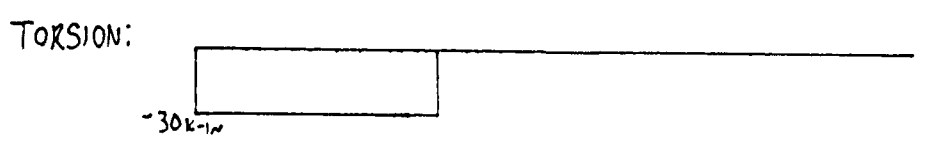
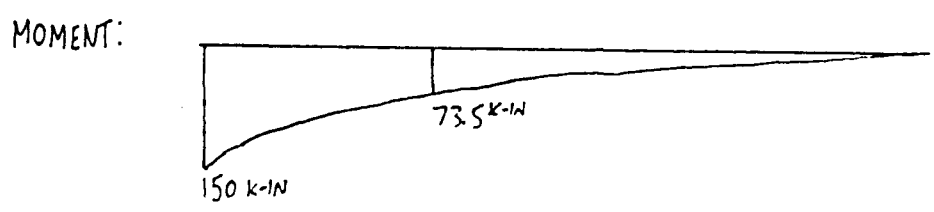
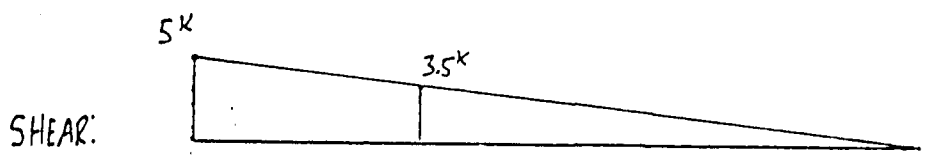
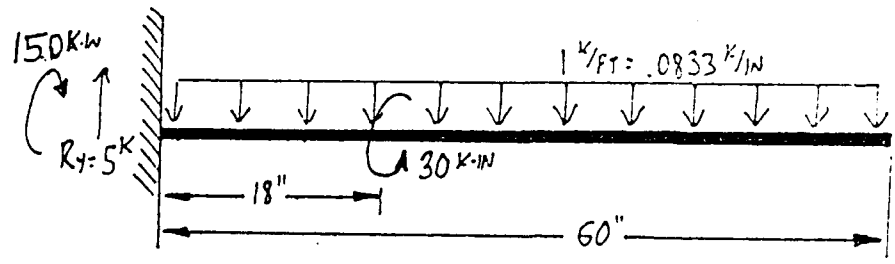

W8x15 DIMENSIONS & PROPERTIES

$A = 4.44 \text{ in}^2$	$I_x = 48.0 \text{ in}^4$	$C_w = 51.8 \text{ in}^6$	$Q_F = 2.38 \text{ in}^3$
$d = 8.11 \text{ in}$	$I_y = 3.41 \text{ in}^4$	$a = 31.4 \text{ in}$	$Q_w = 6.78 \text{ in}^3$
$b_f = 4.015 \text{ in}$	$S_x = 11.8 \text{ in}^3$	$W_{no} = 7.84 \text{ in}^2$	$E = 29000 \text{ ksi}$
$t_w = .245 \text{ in}$	$S_y = 1.7 \text{ in}^3$	$S_w = 2.47 \text{ in}^4$	$G = 11200 \text{ ksi}$
$t_f = .315 \text{ in}$	$J = .136 \text{ in}^4$		

PLANE BENDING STRESSES

A. LONGITUDINAL BENDING STRESSES

$$\sigma_B = M_B / S_x$$

$$\text{AT SUPPORT: } \sigma_B = -150 \text{ k-in} / 11.8 \text{ in}^3 = -12.712 \text{ ksi}$$

$$\text{AT .3L (18")}: \sigma_B = -73.5 \text{ k-in} / 11.8 \text{ in}^3 = -6.229 \text{ ksi}$$

$$\text{AT FREE END: } \sigma_B = 0 \text{ ksi}$$

B. MAXIMUM WEB SHEAR STRESSES

$$\tau_w = VQ_w / I_t w$$

$$\text{AT SUPPORT: } \tau_w = (5^k)(6.78 \text{ in}^3) / (48 \text{ in}^4)(.245 \text{ in}) = 2.883 \text{ ksi}$$

$$\text{AT .3L (18")}: \tau_w = (35^k)(6.78 \text{ in}^3) / (48 \text{ in}^4)(.245 \text{ in}) = 2.018 \text{ ksi}$$

$$\text{AT FREE END: } \tau_w = 0 \text{ ksi}$$

C. MAXIMUM FLANGE SHEAR STRESSES

$$\tau_F = VQ_F / I_{tF}$$

$$\text{AT SUPPORT: } \tau_F = (5^k)(2.38 \text{ in}^3) / (48 \text{ in}^4)(.315 \text{ in}) = .787 \text{ ksi}$$

$$\text{AT } .3L (18''): \quad \tau_F = (3.5^k)(2.38 \text{ in}^3) / (48 \text{ in}^4)(.315 \text{ in}) = .551 \text{ ksi}$$

$$\text{AT FREE END:} \quad \tau_F = 0 \text{ ksi}$$

TORSIONAL STRESSES

A. TORSIONAL FUNCTIONS

$$\text{USE } L/a = 60''/31.4'' = 1.91$$

1) TORSIONAL LOAD 1: $M = 30^k \cdot \text{in}$ AT $18'' (.3L)$

USE CASE 9, $\alpha = .3$

$$\begin{array}{ll} \text{AT SUPPORT:} & \phi \cdot \left[\frac{GJ}{Ma} \right] = 0 \quad \therefore \phi = 0 \\ & \phi'' \cdot \left[\frac{GJa}{M} \right] = .44 \quad \therefore \phi'' = .00027599 \\ & \phi' \cdot \left[\frac{GJ}{M} \right] = 0 \quad \therefore \phi' = 0 \\ & \phi''' \cdot \left[\frac{GJa^2}{M} \right] = -1.0 \quad \therefore \phi''' = -.00001998 \end{array}$$

$$\begin{array}{ll} \text{AT } .3L (18''): & \phi \cdot \left[\frac{GJ}{Ma} \right] = .05 \quad \therefore \phi = .030922 \\ & \phi'' \cdot \left[\frac{GJa}{M} \right] = -.09 \quad \therefore \phi'' = -.00005645 \\ & \phi' \cdot \left[\frac{GJ}{M} \right] = .1 \quad \therefore \phi' = .0019695 \\ & \phi''' \cdot \left[\frac{GJa^2}{M} \right] = -.9 \quad \therefore \phi''' = -.00001798 \end{array}$$

$$\begin{array}{ll} \text{AT FREE END:} & \phi \cdot \left[\frac{GJ}{Ma} \right] = .13 \quad \therefore \phi = .080397 \\ & \phi'' \cdot \left[\frac{GJa}{M} \right] = 0 \quad \therefore \phi'' = 0 \\ & \phi' \cdot \left[\frac{GJ}{M} \right] = .04 \quad \therefore \phi' = .0007878 \\ & \phi''' \cdot \left[\frac{GJa^2}{M} \right] = .04 \quad \therefore \phi''' = 7.99 \times 10^{-7} \end{array}$$

B. STRESS CALCULATIONS

1) TORSIONAL SHEAR STRESSES

$$\tau_t = G t \phi'$$

$$t_F = .315 \text{ in}$$

$$t_W = .245 \text{ in}$$

$$\text{AT SUPPORT: } \tau_{tW} = (11200 \text{ ksi})(.245 \text{ in})(0) = 0 \text{ ksi}$$

$$\tau_{tF} = (11200 \text{ ksi})(.315 \text{ in})(0) = 0 \text{ ksi}$$

$$\text{AT .3L (18")}: \tau_{tW} = (11200 \text{ ksi})(.245 \text{ in})(.0019695) = 5.404 \text{ ksi}$$

$$\tau_{tF} = (11200 \text{ ksi})(.315 \text{ in})(.0019695) = 6.948 \text{ ksi}$$

$$\text{AT FREE END: } \tau_{tW} = (11200 \text{ ksi})(.245 \text{ in})(.0007878) = 2.162 \text{ ksi}$$

$$\tau_{tF} = (11200 \text{ ksi})(.315 \text{ in})(.0007878) = 2.779 \text{ ksi}$$

2) WARPING NORMAL STRESSES

$$\sigma_{ws} = E W_{no} \phi''$$

MAXIMUM AT FLANGE TIPS!

$$W_{no} = 7.84 \text{ in}^2$$

$$\text{AT SUPPORT: } \sigma_{ws} = (29000 \text{ ksi})(7.84 \text{ in}^2)(.00027599) = 62.749 \text{ ksi}$$

$$\text{AT .3L (18")}: \sigma_{ws} = (29000 \text{ ksi})(7.84 \text{ in}^2)(-.00005645) = -12.834 \text{ ksi}$$

$$\text{AT FREE END: } \sigma_{ws} = (29000 \text{ ksi})(7.84 \text{ in}^2)(0) = 0 \text{ ksi}$$

3) WARPING SHEAR STRESSES

$$\tau_{ws} = -\frac{E S_w}{t} \cdot \phi'''$$

MAXIMUM AT FLANGE CENTERS!

$$S_w = 2.47 \text{ in}^4, t_f = .315 \text{ in}$$

$$\text{AT SUPPORT: } \tau_{ws} = -\frac{(29000 \text{ ksi})(2.47 \text{ in}^4)}{(.315 \text{ in})} (-.00001998) = 4.543 \text{ ksi}$$

$$\text{AT .3L (18''): } \tau_{ws} = -\frac{(29000 \text{ ksi})(2.47 \text{ in}^4)}{(.315 \text{ in})} (-.00001798) = 4.089 \text{ ksi}$$

$$\text{AT FREE END: } \tau_{ws} = -\frac{(29000 \text{ ksi})(2.47 \text{ in}^4)}{(.315 \text{ in})} (7.99 \times 10^{-7}) = -.182 \text{ ksi}$$

HAND - CALCULATIONS
FOR PROBLEM 6

BEAM SELECTED: W10x49
END CONDITIONS: FIXED-FREE

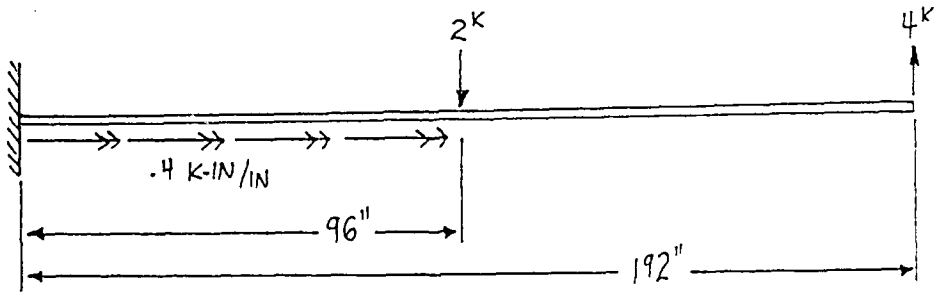

SHEAR & MOMENT DIAGRAMS

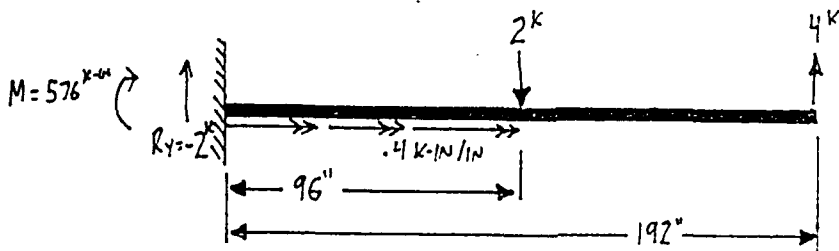

SHEAR:

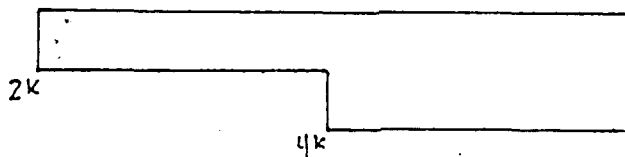

MOMENT:

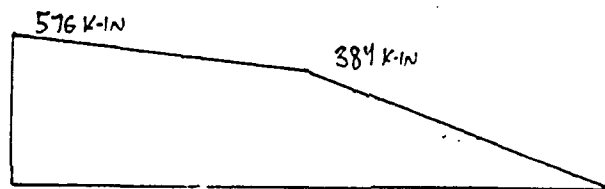

TORSION:

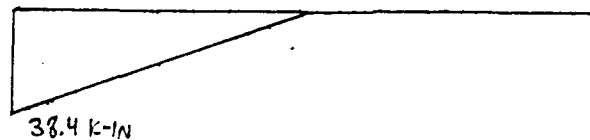

W10x49 DIMENSIONS & PROPERTIES

$A = 14.4 \text{ in}^2$	$I_x = 272 \text{ in}^4$	$C_w = 2070 \text{ in}^6$	$Q_F = 13.0 \text{ in}^3$
$d = 9.98 \text{ in}$	$I_y = 93.4 \text{ in}^4$	$a = 62.4 \text{ in}$	$Q_w = 30.7 \text{ in}^3$
$b_F = 10 \text{ in}$	$S_x = 54.6 \text{ in}^3$	$W_{po} = 23.6 \text{ in}^2$	$E = 29000 \text{ ksi}$
$t_w = .34 \text{ in}$	$S_y = 18.7 \text{ in}^3$	$S_w = 32.9 \text{ in}^4$	$G = 11200 \text{ ksi}$
$t_F = .56 \text{ in}$	$J = 1.38 \text{ in}^4$		

PLANE BENDING STRESSES

A. LONGITUDINAL BENDING STRESSES

$$\sigma_B = M_B / S_x$$

$$\text{AT SUPPORT: } \sigma_B = 576 \text{ k-in} / 54.6 \text{ in}^3 = 10.549 \text{ ksi}$$

$$\text{AT .5L (96")}: \sigma_B = 384 \text{ k-in} / 54.6 \text{ in}^3 = 7.033 \text{ ksi}$$

$$\text{AT FREE END: } \sigma_B = 0 \text{ ksi}$$

B. MAXIMUM WEB SHEAR STRESSES

$$\tau_w = VQ_w / I_{tw}$$

$$\text{AT SUPPORT: } \tau_w = (-2 \text{ k})(30.2 \text{ in}^3) / (272 \text{ in}^4)(.34 \text{ in}) = -.653 \text{ ksi}$$

$$\text{AT .5L (96")}: \tau_w = (-2 \text{ k})(30.2 \text{ in}^3) / (272 \text{ in}^4)(.34 \text{ in}) = -.653 \text{ ksi}$$

$$\text{AT FREE END: } \tau_w = (-4 \text{ k})(30.2 \text{ in}^3) / (272 \text{ in}^4)(.34 \text{ in}) = -1.306 \text{ ksi}$$

C. MAXIMUM FLANGE SHEAR STRESSES

$$\tau_F = VQ_F / I_{tF}$$

$$\text{AT SUPPORT: } \tau_F = (-2 \text{ k})(13.0 \text{ in}^3) / (272 \text{ in}^4)(.56 \text{ in}) = -.171 \text{ ksi}$$

$$\text{AT } .5L(96'') : \tau_F = (-2^k)(13.0 \text{ in}^3) / (272 \text{ in}^4)(.56 \text{ in}) = -.171 \text{ ksi}$$

$$\text{AT FREE END: } \tau_F = (-4^k)(13.0 \text{ in}^3) / (272 \text{ in}^4)(.56 \text{ in}) = -.341 \text{ ksi}$$

TORSIONAL STRESSES

A. TORSIONAL FUNCTIONS

$$\text{USE } L/a = 192'' / 62.4'' = 3.08$$

1) TORSIONAL LOAD 1: $m = .4 \text{ k-in/in}$ FROM $0''$ TO $96''$

USE CASE 10, $\alpha = 5$

$$\begin{array}{ll} \text{AT SUPPORT: } \phi \cdot \left[\frac{GJ}{\pi a^2} \right] = 0 & \therefore \phi = 0 \\ \phi'' \cdot \left[\frac{GJ}{\pi} \right] = .72 & \therefore \phi'' = .000018633 \\ \phi' \cdot \left[\frac{GJ}{\pi} \cdot \frac{2}{a} \right] = 0 & \therefore \phi' = 0 \\ \phi''' \cdot \left[\frac{GJ a}{\pi} \right] = -1.5 & \therefore \phi''' = -6.2211 \times 10^{-7} \end{array}$$

$$\begin{array}{ll} \text{AT } .5L(96'') : \phi \cdot \left[\frac{GJ}{\pi a^2} \right] = .26 & \therefore \phi = .0262 \\ \phi'' \cdot \left[\frac{GJ}{\pi} \right] = -.14 & \therefore \phi'' = -.000003623 \\ \phi' \cdot \left[\frac{GJ}{\pi} \cdot \frac{2}{a} \right] = .30 & \therefore \phi' = .0002422 \\ \phi''' \cdot \left[\frac{GJ a}{\pi} \right] = .15 & \therefore \phi''' = 6.2211 \times 10^{-8} \end{array}$$

$$\begin{array}{ll} \text{AT FREE END: } \phi \cdot \left[\frac{GJ}{\pi a^2} \right] = .40 & \therefore \phi = .0403 \\ \phi'' \cdot \left[\frac{GJ}{\pi} \right] = 0 & \therefore \phi'' = 0 \\ \phi' \cdot \left[\frac{GJ}{\pi} \cdot \frac{2}{a} \right] = .15 & \therefore \phi' = .0001211 \\ \phi''' \cdot \left[\frac{GJ a}{\pi} \right] = .05 & \therefore \phi''' = 2.0737 \times 10^{-8} \end{array}$$

B. STRESS CALCULATIONS

1) TORSIONAL SHEAR STRESSES

$$\tau_t = G t \phi'$$

$$t_F = .56 \text{ in}$$

$$t_w = .34 \text{ in}$$

$$\text{AT SUPPORT: } \tau_{tw} = (11200 \text{ ksi})(.34 \text{ in})(0) = 0 \text{ ksi}$$

$$\tau_{tF} = (11200 \text{ ksi})(.56 \text{ in})(0) = 0 \text{ ksi}$$

$$\text{AT .5L (96")}: \tau_{tw} = (11200 \text{ ksi})(.34 \text{ in})(.0002422) = .9222 \text{ ksi}$$

$$\tau_{tF} = (11200 \text{ ksi})(.56 \text{ in})(.0002422) = 1.519 \text{ ksi}$$

$$\text{AT FREE END: } \tau_{tw} = (11200 \text{ ksi})(.34 \text{ in})(.0001211) = .461 \text{ ksi}$$

$$\tau_{tF} = (11200 \text{ ksi})(.56 \text{ in})(.0001211) = .760 \text{ ksi}$$

2) WARPING NORMAL STRESSES

$$\sigma_{ws} = E W_{\omega} \phi''$$

MAXIMUM AT FLANGE TIPS!

$$W_{\omega} = 23.6 \text{ in}^2$$

$$\text{AT SUPPORT: } \sigma_{ws} = (29000 \text{ ksi})(23.6 \text{ in}^2)(.000018633) = 12.752 \text{ ksi}$$

$$\text{AT .5L (96")}: \sigma_{ws} = (29000 \text{ ksi})(23.6 \text{ in}^2)(-.000003623) = -2.480 \text{ ksi}$$

$$\text{AT FREE END: } \sigma_{ws} = (29000 \text{ ksi})(23.6 \text{ in}^2)(0) = 0 \text{ ksi}$$

3) WARPING SHEAR STRESSES

$$\tau_{ws} = -\frac{E S_w}{t} \phi'''$$

MAXIMUM AT FLANGE CENTERS!

$$S_w = 32.9 \text{ in}^4, t_f = .56 \text{ in}$$

$$\text{AT SUPPORT: } \tau_{ws} = \frac{-(29000 \text{ ksi})(32.9 \text{ in}^4)}{(.56 \text{ in})} (-6.2211 \times 10^{-7}) = 1.060 \text{ ksi}$$

$$\text{AT .5L (.96'')}: \tau_{ws} = \frac{-(29000 \text{ ksi})(32.9 \text{ in}^4)}{(.56 \text{ in})} (6.2211 \times 10^{-8}) = -.106 \text{ ksi}$$

$$\text{AT FREE END: } \tau_{ws} = \frac{-(29000 \text{ ksi})(32.9 \text{ in}^4)}{(.56 \text{ in})} (2.0737 \times 10^{-8}) = -.035 \text{ ksi}$$

HAND-CALCULATIONS
FOR PROBLEM 7

BEAM SELECTED: W6x15
END CONDITIONS: FIXED-FREE

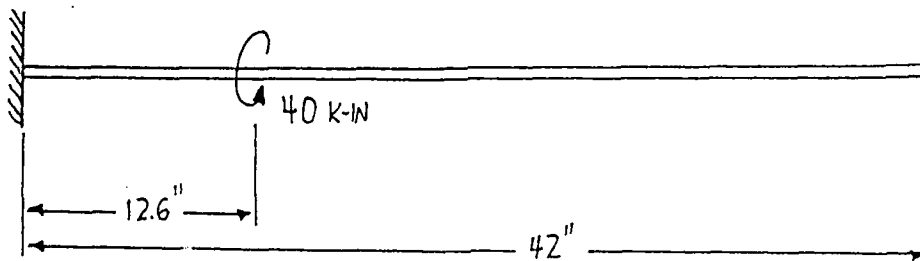

SHEAR & MOMENT DIAGRAMS

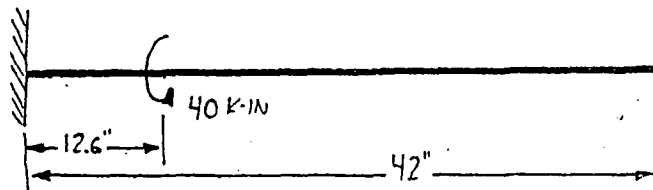

NO PLANE BENDING LOADS OR STRESSES

TORSION:

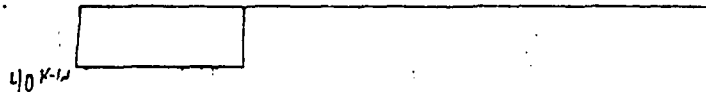

W6x15 DIMENSIONS & PROPERTIES

$A = 4.43 \text{ in}^2$	$I_x = 29.1 \text{ in}^4$	$C_w = 76.5 \text{ in}^6$	$Q_F = 2.18 \text{ in}^3$
$d = 5.99 \text{ in}$	$I_y = 9.32 \text{ in}^4$	$a = 44.2 \text{ in}$	$Q_w = 5.39 \text{ in}^3$
$b_f = 5.99 \text{ in}$	$S_x = 9.72 \text{ in}^3$	$W_{no} = 8.58 \text{ in}^2$	$E = 29000 \text{ ksi}$
$t_w = .23 \text{ in}$	$S_y = 3.11 \text{ in}^3$	$S_w = 3.34 \text{ in}^4$	$G = 11200 \text{ ksi}$
$t_f = .26 \text{ in}$	$J = .10 \text{ in}^4$		

TORSIONAL STRESSES

A. TORSIONAL FUNCTIONS

$$\text{USE } L/a = 42''/44.2'' = .95$$

1) TORSIONAL LOAD 1: $M = 40 \text{ K-IN AT } 12.6" \text{ (3L)}$

USE CASE 9, $\alpha = .3$

$$\begin{aligned} \text{AT SUPPORT: } \phi \cdot \left[\frac{GJ}{Ma} \right] &= 0 & \therefore \phi &= 0 \\ \phi'' \cdot \left[\frac{GJa}{M} \right] &= .26 & \therefore \phi'' &= .00021008 \\ \phi' \cdot \left[\frac{GJ}{M} \right] &= 0 & \therefore \phi' &= 0 \\ \phi''' \cdot \left[\frac{GJa^2}{M} \right] &= -.10 & \therefore \phi''' &= -.00001828 \end{aligned}$$

$$\begin{aligned} \text{AT 3L (12.6")}: \phi \cdot \left[\frac{GJ}{Ma} \right] &= .005 & \therefore \phi &= .007893 \\ \phi'' \cdot \left[\frac{GJa}{M} \right] &= -.02 & \therefore \phi'' &= -.00001616 \\ \phi' \cdot \left[\frac{GJ}{M} \right] &= .04 & \therefore \phi' &= .00142857 \\ \phi''' \cdot \left[\frac{GJa^2}{M} \right] &= -.97 & \therefore \phi''' &= -.00001773 \end{aligned}$$

$$\begin{aligned} \text{AT FREE END: } \phi \cdot \left[\frac{GJ}{Ma} \right] &= .03 & \therefore \phi &= .047357 \\ \phi'' \cdot \left[\frac{GJa}{M} \right] &= 0 & \therefore \phi'' &= 0 \\ \phi' \cdot \left[\frac{GJ}{M} \right] &= .03 & \therefore \phi' &= .00107143 \\ \phi''' \cdot \left[\frac{GJa^2}{M} \right] &= .03 & \therefore \phi''' &= 5.4843 \times 10^{-7} \end{aligned}$$

B. STRESS CALCULATIONS

1) TORSIONAL SHEAR STRESSES

$$\tau_t = Gt\phi'$$

$$\begin{aligned} t_F &= .26" \\ t_W &= .23" \end{aligned}$$

$$\text{AT SUPPORT: } \tau_{tW} = (11200 \text{ ksi})(.23 \text{ in})(0) = 0 \text{ ksi}$$

$$\tau_{tF} = (11200 \text{ ksi})(.26 \text{ in})(0) = 0 \text{ ksi}$$

$$\text{AT .3L (12.6'') : } \tau_{tw} = (11200 \text{ ksi})(.23 \text{ in})(.00142857) = 3.680 \text{ ksi}$$

$$\tau_{tf} = (11200 \text{ ksi})(.26 \text{ in})(.00142857) = 4.160 \text{ ksi}$$

$$\text{AT FREE END: } \tau_{tw} = (11200 \text{ ksi})(.23 \text{ in})(.00107143) = 2.760 \text{ ksi}$$

$$\tau_{tf} = (11200 \text{ ksi})(.26 \text{ in})(.00107143) = 3.120 \text{ ksi}$$

2) WARPING NORMAL STRESSES

MAXIMUM AT FLANGE TIPS!

$$\sigma_{ws} = E W_{no} \phi''$$

$$W_{no} = 8.58 \text{ in}^2$$

$$\text{AT SUPPORT: } \sigma_{ws} = (29000 \text{ ksi})(8.58 \text{ in}^2)(.00021008) = 52.272 \text{ ksi}$$

$$\text{AT .3L (12.6'') : } \sigma_{ws} = (29000 \text{ ksi})(8.58 \text{ in}^2)(-.00001616) = -4.021 \text{ ksi}$$

$$\text{AT FREE END: } \sigma_{ws} = (29000 \text{ ksi})(8.58 \text{ in}^2)(0) = 0 \text{ ksi}$$

3) WARPING SHEAR STRESSES

MAXIMUM AT FLANGE CENTERS!

$$\tau_{ws} = \frac{-E S_w}{t_f} \phi'''$$

$$S_w = 3.34 \text{ in}^4, t_f = .26 \text{ in}$$

$$\text{AT SUPPORT: } \tau_{ws} = \frac{-(29000 \text{ ksi})(3.34 \text{ in}^4)}{(.26 \text{ in})} (-.00001828) = 6.810 \text{ ksi}$$

$$\text{AT .3L (12.6'') : } \tau_{ws} = \frac{-(29000 \text{ ksi})(3.34 \text{ in}^4)}{(.26 \text{ in})} (-.00001773) = 6.605 \text{ ksi}$$

$$\text{AT FREE END: } \tau_{ws} = \frac{-(29000 \text{ ksi})(3.34 \text{ in}^4)}{(.26 \text{ in})} (5.4843 \times 10^{-7}) = -.204 \text{ ksi}$$

HAND-CALCULATIONS
FOR PROBLEM 8

BEAM SELECTED: W8x67
END CONDITIONS: FIXED-FREE

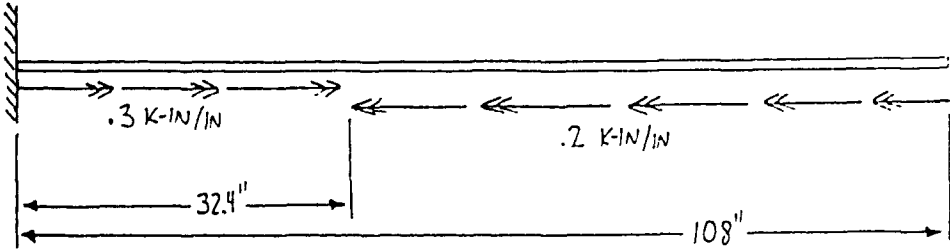

SHEAR & MOMENT DIAGRAMS

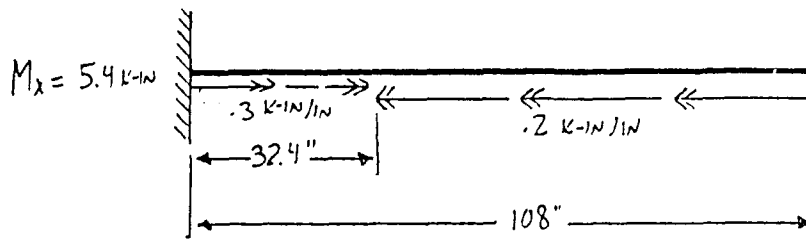

NO PLANE BENDING LOADS OR STRESSES



W8x67 DIMENSIONS & PROPERTIES

$A = 19.7 \text{ in}^2$	$I_x = 272 \text{ in}^4$	$C_w = 1440 \text{ in}^6$	$Q_x = 14.6 \text{ in}^3$
$d = 9.0 \text{ in}$	$I_y = 88.6 \text{ in}^4$	$a = 27.2 \text{ in}$	$Q_w = 35.1 \text{ in}^3$
$b_f = 8.28 \text{ in}$	$S_x = 60.4 \text{ in}^3$	$W_{ho} = 16.7 \text{ in}^2$	$E = 29000 \text{ ksi}$
$t_w = .57 \text{ in}$	$S_y = 21.4 \text{ in}^3$	$S_w = 32.3 \text{ in}^4$	$G = 11200 \text{ ksi}$
$t_f = .935 \text{ in}$	$J = 5.05 \text{ in}^4$		

TORSIONAL STRESSES

A. TORSIONAL FUNCTIONS

$$\text{USE } L/a = 108'' / 27.2'' = 3.97$$

TORSIONAL LOAD 1
 +
 TORSIONAL LOAD 2
 ↓
 COMBINED TORSIONAL LOAD

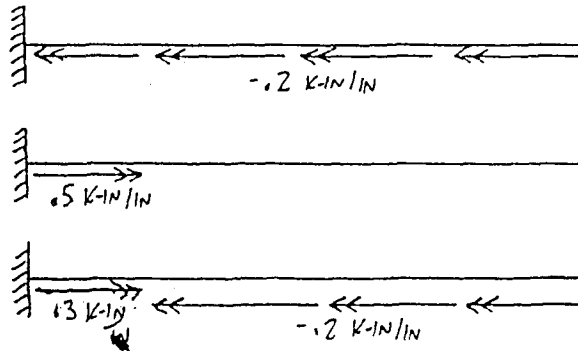

1) TORSIONAL LOAD 1: $m = -0.2 \text{ k-in/in}$ FROM $0''$ TO $108''$

USE CASE 10, $\alpha = 1.0$

AT SUPPORT:

$\phi \cdot \left[\frac{GJ}{ma^2} \right] = 0$	$\therefore \phi = 0$
$\phi'' \cdot \left[\frac{GJ}{m} \right] = 3.0$	$\therefore \phi'' = -0.000010608$
$\phi' \cdot \left[\frac{GJ}{m} \cdot \frac{2}{a} \right] = 0$	$\therefore \phi' = 0$
$\phi''' \cdot \left[\frac{GJa}{m} \right] = -4.0$	$\therefore \phi''' = 5.2 \times 10^{-7}$

AT .3L (32.4''): $\phi \cdot \left[\frac{GJ}{ma^2} \right] = 1.3$ $\therefore \phi = -0.00340096$

$\phi'' \cdot \left[\frac{GJ}{m} \right] = .3$	$\therefore \phi'' = -0.000001061$
$\phi' \cdot \left[\frac{GJ}{m} \cdot \frac{2}{a} \right] = 3.3$	$\therefore \phi' = -0.0001587$
$\phi''' \cdot \left[\frac{GJa}{m} \right] = -1.1$	$\therefore \phi''' = 1.43 \times 10^{-7}$

AT FREE END:

$\phi \cdot \left[\frac{GJ}{ma^2} \right] = 5.0$	$\therefore \phi = -0.0130806$
$\phi'' \cdot \left[\frac{GJ}{m} \right] = 0$	$\therefore \phi'' = 0$
$\phi' \cdot \left[\frac{GJ}{m} \cdot \frac{2}{a} \right] = 1.7$	$\therefore \phi' = -0.00008175$
$\phi''' \cdot \left[\frac{GJa}{m} \right] = .8$	$\therefore \phi''' = -1.04 \times 10^{-7}$

2) TORSIONAL LOAD 2: $m = .5 \text{ K-IN/IN}$ FROM $0''$ TO $32.4''$

USE CASE 10, $\alpha = .3$

AT SUPPORT:

$$\begin{aligned} \phi \cdot \left[\frac{GJ}{ma^2} \right] &= 0 & \therefore \phi &= 0 \\ \phi'' \cdot \left[\frac{GJ}{3} \right] &= .5 & \therefore \phi'' &= 4.42 \times 10^{-6} \\ \phi' \cdot \left[\frac{GJ}{3} \cdot \frac{2}{a} \right] &= 0 & \therefore \phi' &= 0 \\ \phi''' \cdot \left[\frac{GJa}{3} \right] &= -1.2 & \therefore \phi''' &= -3.9 \times 10^{-7} \end{aligned}$$

AT .3L (32.4''):

$$\begin{aligned} \phi \cdot \left[\frac{GJ}{ma^2} \right] &= .12 & \therefore \phi &= .0007848 \\ \phi'' \cdot \left[\frac{GJ}{3} \right] &= -.09 & \therefore \phi'' &= -7.956 \times 10^{-7} \\ \phi' \cdot \left[\frac{GJ}{3} \cdot \frac{2}{a} \right] &= .18 & \therefore \phi' &= .00002164 \\ \phi''' \cdot \left[\frac{GJa}{3} \right] &= .08 & \therefore \phi''' &= 2.6 \times 10^{-8} \end{aligned}$$

AT FREE END:

$$\begin{aligned} \phi \cdot \left[\frac{GJ}{ma^2} \right] &= .22 & \therefore \phi &= .00143897 \\ \phi'' \cdot \left[\frac{GJ}{3} \right] &= 0 & \therefore \phi'' &= 0 \\ \phi' \cdot \left[\frac{GJ}{3} \cdot \frac{2}{a} \right] &= 0 & \therefore \phi' &= 0 \\ \phi''' \cdot \left[\frac{GJa}{3} \right] &= 0 & \therefore \phi''' &= 0 \end{aligned}$$

3) SUMMATION OF $\phi, \phi'', \phi', \phi'''$ FOR LOADS 1 AND 2

AT SUPPORT:

$$\begin{aligned} \phi &= 0 \\ \phi'' &= -6.188 \times 10^{-6} \\ \phi' &= 0 \\ \phi''' &= 1.3 \times 10^{-7} \end{aligned}$$

$$\begin{aligned} \text{AT .3L (32.4")}: \quad \phi &= -2.6162 \times 10^{-3} \\ \phi'' &= -1.8566 \times 10^{-6} \\ \phi' &= -.0001371 \\ \phi''' &= 1.69 \times 10^{-7} \end{aligned}$$

$$\begin{aligned} \text{AT FREE END:} \quad \phi &= -.011642 \\ \phi'' &= 0 \\ \phi' &= -.00008175 \\ \phi''' &= -1.04 \times 10^{-7} \end{aligned}$$

B. STRESS CALCULATIONS

1) TORSIONAL SHEAR STRESSES

$$\tau_t = G t \phi'$$

$$\begin{aligned} t_F &= .935 \text{ in} \\ t_W &= .57 \text{ in} \end{aligned}$$

$$\begin{aligned} \text{AT SUPPORT:} \quad \tau_{tW} &= (11200 \text{ ksi})(.57 \text{ in})(0) = 0 \text{ ksi} \\ \tau_{tF} &= (11200 \text{ ksi})(.935 \text{ in})(0) = 0 \text{ ksi} \end{aligned}$$

$$\begin{aligned} \text{AT .3L (32.4")}: \quad \tau_{tW} &= (11200 \text{ ksi})(.57 \text{ in})(-.0001371) = -.875 \text{ ksi} \\ \tau_{tF} &= (11200 \text{ ksi})(.935 \text{ in})(-.0001371) = -1.436 \text{ ksi} \end{aligned}$$

$$\begin{aligned} \text{AT FREE END:} \quad \tau_{tW} &= (11200 \text{ ksi})(.57 \text{ in})(-.00008175) = -.522 \text{ ksi} \\ \tau_{tF} &= (11200 \text{ ksi})(.935 \text{ in})(-.00008175) = -.856 \text{ ksi} \end{aligned}$$

2) WARPING NORMAL STRESSES

$$\sigma_{ws} = E W_{no} \phi''$$

MAXIMUM AT FLANGE TIPS!

$$W_{no} = 16.7 \text{ in}^2$$

$$\text{AT SUPPORT: } \sigma_{ws} = (29000 \text{ ksi})(16.7 \text{ in}^2)(-6.188 \times 10^{-6}) = -2.997 \text{ ksi}$$

$$\text{AT .3L (32.4''): } \sigma_{ws} = (29000 \text{ ksi})(16.7 \text{ in}^2)(-1.8566 \times 10^{-6}) = -.899 \text{ ksi}$$

$$\text{AT FREE END: } \sigma_{ws} = (29000 \text{ ksi})(16.7 \text{ in}^2)(0) = 0 \text{ ksi}$$

3) WARPING SHEAR STRESSES

$$\tau_w = \frac{-E S_w}{t} \phi'''$$

MAXIMUM AT FLANGE CENTERS!

$$S_w = 32.3 \text{ in}^4, t_F = .935 \text{ in}$$

$$\text{AT SUPPORT: } \tau_w = \frac{-(29000 \text{ ksi})(32.3 \text{ in}^4)}{(.935 \text{ in})} (1.3 \times 10^{-7}) = -.130 \text{ ksi}$$

$$\text{AT .3L (32.4''): } \tau_w = \frac{-(29000 \text{ ksi})(32.3 \text{ in}^4)}{(.935 \text{ in})} (1.69 \times 10^{-7}) = -.169 \text{ ksi}$$

$$\text{AT FREE END: } \tau_w = \frac{-(29000 \text{ ksi})(32.3 \text{ in}^4)}{(.935 \text{ in})} (-1.04 \times 10^{-7}) = .104 \text{ ksi}$$

HAND-CALCULATIONS
FOR PROBLEM 9

BEAM SELECTED: C10x20
END CONDITIONS: FIXED-FREE

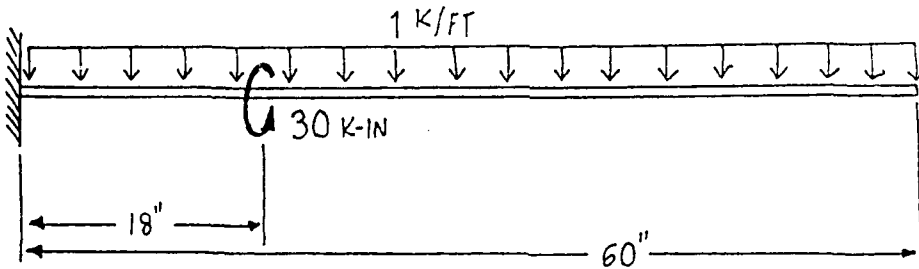

SHEAR & MOMENT DIAGRAMS

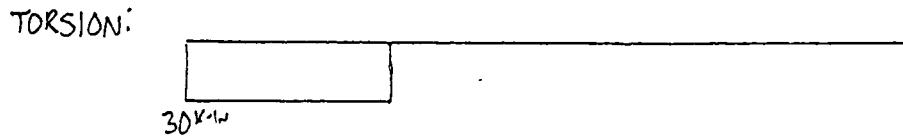
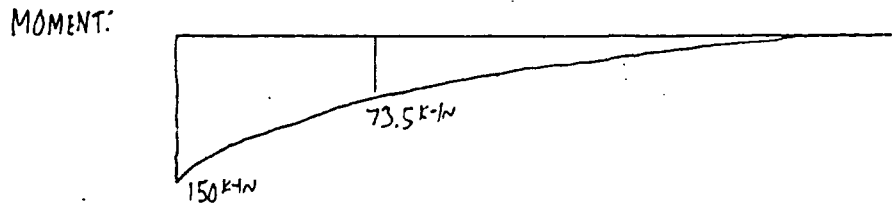
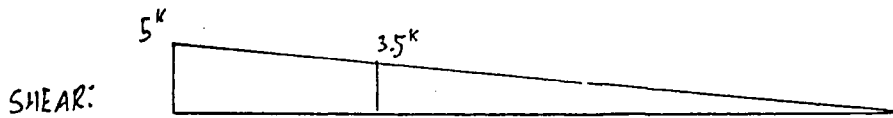
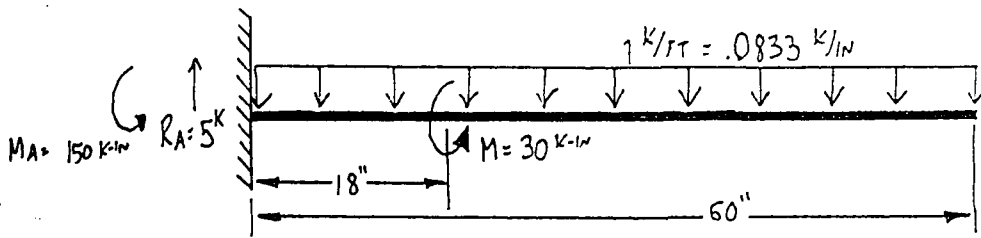

C10x20 DIMENSIONS & PROPERTIES

$A = 5.88 \text{ in}^2$	$I_y = 2.81 \text{ in}^4$	$W_{n0} = 8.24 \text{ in}^2$	$Q_F = 5.04 \text{ in}^3$
$d = 10 \text{ in}$	$S_x = 15.8 \text{ in}^3$	$W_{n2} = 3.95 \text{ in}^2$	$Q_w = 9.77 \text{ in}^3$
$b_f = 2.739 \text{ in}$	$S_y = 1.32 \text{ in}^3$	$S_{w1} = 3.10 \text{ in}^4$	$E = 29000 \text{ ksi}$
$t_f = .436 \text{ in}$	$J = .37 \text{ in}^4$	$S_{w2} = 2.39 \text{ in}^4$	$G = 11200 \text{ ksi}$
$t_w = .379 \text{ in}$	$C_w = 56.9 \text{ in}^6$	$S_{w3} = 1.19 \text{ in}^4$	
$I_x = 78.9 \text{ in}^4$	$a = 19.9 \text{ in}$		

PLANE BENDING STRESSES

A. LONGITUDINAL BENDING STRESSES

$$\sigma_B = M/S_x$$

$$\text{AT SUPPORT: } \sigma_B = -150 \text{ k-in} / 15.8 = -9.494 \text{ ksi}$$

$$\text{AT .3L (18") : } \sigma_B = -73 \text{ k-in} / 15.8 = -4.652 \text{ ksi}$$

$$\text{AT FREE END: } \sigma_B = 0 \text{ ksi}$$

B. MAXIMUM WEB SHEAR STRESSES

$$\tau_w = VQ_w / I_t w$$

$$\text{AT SUPPORT: } \tau_w = (5^k)(9.77 \text{ in}^3) / (78.9 \text{ in}^4)(.379 \text{ in}) = 1.634 \text{ ksi}$$

$$\text{AT .3L (18") : } \tau_w = (3.5^k)(9.77 \text{ in}^3) / (78.9 \text{ in}^4)(.379 \text{ in}) = 1.144 \text{ ksi}$$

$$\text{AT FREE END: } \tau_w = 0 \text{ ksi}$$

C. MAXIMUM FLANGE SHEAR STRESSES

$$\tau_f = VQ_f / I_t f$$

$$\text{AT SUPPORT: } \tau_f = (5^k)(5.04 \text{ in}^3) / (78.9 \text{ in}^4)(.436 \text{ in}) = 0.733 \text{ ksi}$$

AT .3L (18") : $\tau_F = (3.5^k)(5.04 \text{ in}^3) / ((78.9 \text{ in}^4)(.436 \text{ in})) = 0.513 \text{ ksi}$

AT FREE END: $\tau_F = 0 \text{ ksi}$

TORSIONAL STRESSES

A. TORSIONAL FUNCTIONS

USE $L/a = 60"/19.9" = 3.01$

1) TORSIONAL LOAD 1 : $M = 30 \text{ k-in}$ AT 18" (.3L)

USE CASE 9, $\alpha = .3$

AT SUPPORT :

$\phi \cdot \left[\frac{GJ}{Ma} \right] = 0$	$\therefore \phi = 0$
$\phi'' \cdot \left[\frac{GJa}{M} \right] = .59$	$\therefore \phi'' = .0002146$
$\phi' \cdot \left[\frac{GJ}{M} \right] = 0$	$\therefore \phi' = 0$
$\phi''' \cdot \left[\frac{GJa^2}{M} \right] = -1.0$	$\therefore \phi''' = -.00001828$

AT .3L (18") :

$\phi \cdot \left[\frac{GJ}{Ma} \right] = .13$	$\therefore \phi = .018728$
$\phi'' \cdot \left[\frac{GJa}{M} \right] = -.17$	$\therefore \phi'' = -.00006184$
$\phi' \cdot \left[\frac{GJ}{M} \right] = .18$	$\therefore \phi' = .0013031$
$\phi''' \cdot \left[\frac{GJa^2}{M} \right] = -.82$	$\therefore \phi''' = -.00001499$

AT FREE END:

$\phi \cdot \left[\frac{GJ}{Ma} \right] = .30$	$\therefore \phi = .043219$
$\phi'' \cdot \left[\frac{GJa}{M} \right] = 0$	$\therefore \phi'' = 0$
$\phi' \cdot \left[\frac{GJ}{M} \right] = .04$	$\therefore \phi' = .0002896$
$\phi''' \cdot \left[\frac{GJa^2}{M} \right] = .04$	$\therefore \phi''' = 7.3123 \times 10^{-7}$

2) TORSIONAL LOAD 2: DUE TO ECCENTRICITY OF UNIFORM DISTRIBUTED LOAD ($w = 1 \text{ k/in}$) THROUGH CHANNEL SHEAR CENTER

$$\begin{aligned}
 e^0 &= E_0 + \bar{X} - \frac{tw}{2} & E_0 &= .826 \text{ in}, \bar{X} = .606 \text{ in} \\
 &= .826 \text{ in} + .606 \text{ in} - \frac{.379 \text{ in}}{2} & tw &= .379 \text{ in} \\
 &= 1.24 \text{ in}
 \end{aligned}$$

$$\begin{aligned}
 \therefore m &= w \cdot e \\
 &= .0833 \text{ k/in} \cdot 1.24 \text{ in} = .103 \text{ k-in/in FROM } 0'' \text{ TO } 60''
 \end{aligned}$$

USE CASE 10 $\alpha = 1.0$

$$\begin{array}{ll}
 \text{AT SUPPORT: } \phi \cdot \left[\frac{GJ}{ma^2} \right] = 0 & \therefore \phi = 0 \\
 \phi'' \cdot \left[\frac{GJ}{m} \right] = 2.0 & \therefore \phi'' = .00004971 \\
 \phi' \cdot \left[\frac{GJ}{m} \cdot \frac{2}{a} \right] = 0 & \therefore \phi' = 0 \\
 \phi''' \cdot \left[\frac{GJa}{m} \right] = -3.0 & \therefore \phi''' = -.000003747
 \end{array}$$

$$\begin{array}{ll}
 \text{AT .3L (18'')}: \phi \cdot \left[\frac{GJ}{ma^2} \right] = .6 & \therefore \phi = .0059057 \\
 \phi'' \cdot \left[\frac{GJ}{m} \right] = .3 & \therefore \phi'' = .000007456 \\
 \phi' \cdot \left[\frac{GJ}{a} \cdot \frac{2}{a} \right] = 1.9 & \therefore \phi' = .00046989 \\
 \phi''' \cdot \left[\frac{GJa}{m} \right] = -1.1 & \therefore \phi''' = -.000001373
 \end{array}$$

$$\begin{array}{ll}
 \text{AT FREE END: } \phi \cdot \left[\frac{GJ}{ma^2} \right] = 2.4 & \therefore \phi = .023623 \\
 \phi'' \cdot \left[\frac{GJ}{m} \right] = 0 & \therefore \phi'' = 0 \\
 \phi' \cdot \left[\frac{GJ}{m} \cdot \frac{2}{a} \right] = 1.4 & \therefore \phi' = .00034623 \\
 \phi''' \cdot \left[\frac{GJa}{m} \right] = .7 & \therefore \phi''' = .000000874
 \end{array}$$

3) SUMMATION OF $\phi, \phi'', \phi', \phi'''$ FOR LOADS 1 AND 2

AT SUPPORT:

$$\begin{aligned}\phi &= 0 \\ \phi'' &= .0002643 \\ \phi' &= 0 \\ \phi''' &= -.00002203\end{aligned}$$

AT .3L (18"):

$$\begin{aligned}\phi &= .0246337 \\ \phi'' &= -.00005438 \\ \phi' &= .0017730 \\ \phi''' &= -.00001636\end{aligned}$$

AT FREE END:

$$\begin{aligned}\phi &= .066842 \\ \phi'' &= 0 \\ \phi' &= .0006358 \\ \phi''' &= .000001605\end{aligned}$$

B. STRESS CALCULATIONS

1) TORSIONAL SHEAR STRESSES

$$\tau_t = G t \phi'$$

$$\begin{aligned}t_F &= .436 \text{ in} \\ t_W &= .379 \text{ in}\end{aligned}$$

AT SUPPORT:

$$\begin{aligned}\tau_{tW} &= (11200 \text{ ksi})(.379 \text{ in})(0) = 0 \text{ ksi} \\ \tau_{tF} &= (11200 \text{ ksi})(.436 \text{ in})(0) = 0 \text{ ksi}\end{aligned}$$

AT .3L (18"):

$$\begin{aligned}\tau_{tW} &= (11200 \text{ ksi})(.379 \text{ in})(.0017730) = 7.526 \text{ ksi} \\ \tau_{tF} &= (11200 \text{ ksi})(.436 \text{ in})(.0017730) = 8.658 \text{ ksi}\end{aligned}$$

AT FREE END: $\tau_{tw} = (11200 \text{ ksi})(.379 \text{ in})(.0006358) = 2.699 \text{ ksi}$
 $\tau_{tF} = (11200 \text{ ksi})(.436 \text{ in})(.0006358) = 3.105 \text{ ksi}$

2) WARPING NORMAL STRESSES

$$\sigma_{ws} = E W_n \phi''$$

$$W_{n0} = 8.24 \text{ in}^2$$

$$W_{n2} = 3.95 \text{ in}^2$$

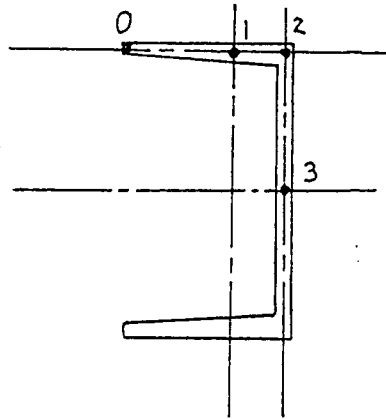

AT SUPPORT: $\sigma_{ws_0} = (29000 \text{ ksi})(8.24 \text{ in}^2)(.0002643) = 63.157 \text{ ksi}$
 $\sigma_{ws_2} = (29000 \text{ ksi})(3.95 \text{ in}^2)(.0002643) = 30.276 \text{ ksi}$

AT .3L (18"): $\sigma_{ws_0} = (29000 \text{ ksi})(8.24 \text{ in}^2)(-.00005438) = -12.995 \text{ ksi}$
 $\sigma_{ws_2} = (29000 \text{ ksi})(3.95 \text{ in}^2)(-.00005438) = -6.229 \text{ ksi}$

AT FREE END: $\sigma_{ws_0} = (29000 \text{ ksi})(8.24 \text{ in}^2)(0) = 0 \text{ ksi}$
 $\sigma_{ws_2} = (29000 \text{ ksi})(3.95 \text{ in}^2)(0) = 0 \text{ ksi}$

3) WARPING SHEAR STRESSES

$$\tau_{ws} = \frac{-ES_w}{t} \phi''' \quad t_f = .436 \text{ in}, t_w = .379 \text{ in}$$

$$S_{w1} = 3.10 \text{ in}^4, S_{w2} = 2.39 \text{ in}^4, S_{w3} = 1.19 \text{ in}^4$$

AT SUPPORT: $\tau_{w1} = \frac{-(29000 \text{ ksi})(3.10 \text{ in}^4)}{(.436 \text{ in})} (-.00002203) = 4.542 \text{ ksi}$

$$\tau_{w2} = \frac{-(29000 \text{ ksi})(2.39 \text{ in}^4)}{(.436 \text{ in})} (-.00002203) = 3.502 \text{ ksi}$$

$$\tau_{w3} = \frac{-(29000 \text{ ksi})(1.19 \text{ in}^4)}{(.379 \text{ in})} (-.00002203) = 2.006 \text{ ksi}$$

AT .3L (18"): $\tau_{w1} = \frac{-(29000 \text{ ksi})(3.10 \text{ in}^4)}{(.436 \text{ in})} (-.00001636) = 3.373 \text{ ksi}$

$$\tau_{w2} = \frac{-(29000 \text{ ksi})(2.39 \text{ in}^4)}{(.436 \text{ in})} (-.00001636) = 2.601 \text{ ksi}$$

$$\tau_{w3} = \frac{-(29000 \text{ ksi})(1.19 \text{ in}^4)}{(.379 \text{ in})} (-.00001636) = 1.490 \text{ ksi}$$

AT FREE END: $\tau_{w1} = \frac{-(29000 \text{ ksi})(3.10 \text{ in}^4)}{(.436 \text{ in})} (.000001605) = -.331 \text{ ksi}$

$$\tau_{w2} = \frac{-(29000 \text{ ksi})(2.39 \text{ in}^4)}{(.436 \text{ in})} (.000001605) = -.255 \text{ ksi}$$

$$\tau_{w3} = \frac{-(29000 \text{ ksi})(1.19 \text{ in}^4)}{(.379 \text{ in})} (.000001605) = -.146 \text{ ksi}$$

HAND-CALCULATIONS
FOR PROBLEM 10

BEAM SELECTED: C12 x 30
END CONDITIONS: FIXED-FREE

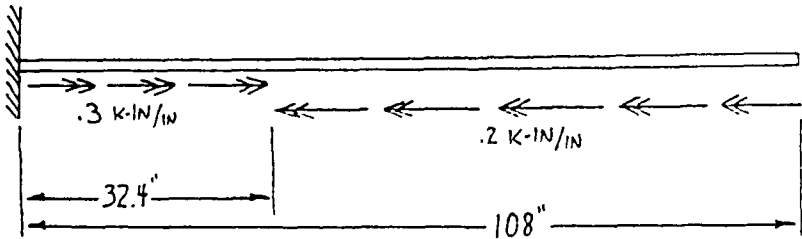

SHEAR & MOMENT DIAGRAMS

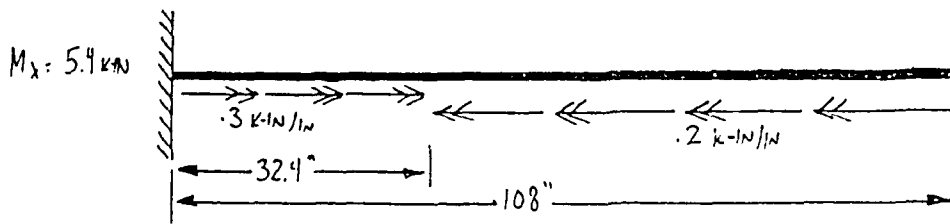

NO PLANE BENDING LOADS OR STRESSES

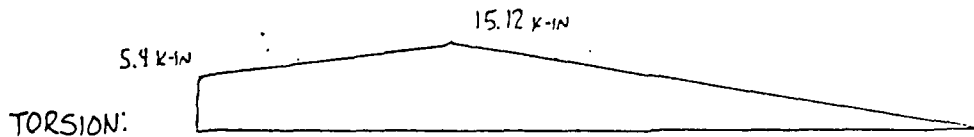

C12x30 DIMENSIONS & PROPERTIES

$A = 8.82 \text{ in}^2$	$I_y = 5.14 \text{ in}^4$	$W_{n0} = 11.70 \text{ in}^2$	$Q_F = 7.84 \text{ in}^3$
$d = 12 \text{ in}$	$S_x = 27 \text{ in}^3$	$W_{n2} = 5.02 \text{ in}^2$	$Q_w = 17.0 \text{ in}^3$
$b_f = 3.77 \text{ in}$	$S_y = 2.06 \text{ in}^3$	$S_{w1} = 6.01 \text{ in}^4$	$E = 29000 \text{ ksi}$
$t_w = .51 \text{ in}$	$J = .865 \text{ in}^4$	$S_{w2} = 4.91 \text{ in}^4$	$G = 11200 \text{ ksi}$
$t_f = .501 \text{ in}$	$C_w = 151 \text{ in}^6$	$S_{w3} = 2.45 \text{ in}^4$	
$I_x = 162 \text{ in}^4$	$a = 21.3 \text{ in}$		

TORSIONAL STRESSES

A. TORSIONAL FUNCTIONS

$$\text{USE } L/a = 108'' / 21.3'' = 5.07$$

TORSIONAL LOAD 1
+
TORSIONAL LOAD 2
↓
COMBINED TORSIONAL LOAD

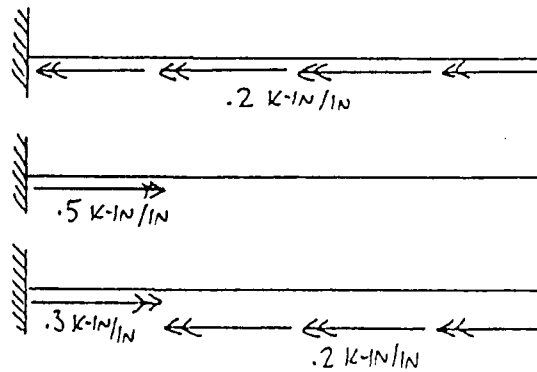

1) TORSIONAL LOAD 1: $m = -0.2 \text{ k-in/in}$ FROM $0''$ TO $108''$

USE CASE 10, $\alpha = 1.0$

AT SUPPORT:

$\phi \cdot \left[\frac{GJ}{ma^2} \right] = 0$	$\therefore \phi = 0$
$\phi'' \cdot \left[\frac{GJ}{m} \right] = 4.0$	$\therefore \phi'' = -0.000082576$
$\phi' \cdot \left[\frac{GJ}{m} \cdot \frac{2}{a} \right] = 0$	$\therefore \phi' = 0$
$\phi''' \cdot \left[\frac{GJa}{m} \right] = -5.0$	$\therefore \phi''' = 4.846 \times 10^{-6}$

AT .3L (32.4''):

$\phi \cdot \left[\frac{GJ}{ma^2} \right] = 2.5$	$\therefore \phi = -0.02342$
$\phi'' \cdot \left[\frac{GJ}{m} \right] = .3$	$\therefore \phi'' = -6.193 \times 10^{-6}$
$\phi' \cdot \left[\frac{GJ}{m} \cdot \frac{2}{a} \right] = 4.8$	$\therefore \phi' = -0.0010553$
$\phi''' \cdot \left[\frac{GJa}{m} \right] = -1.0$	$\therefore \phi''' = 9.6921 \times 10^{-7}$

AT FREE END:

$\phi \cdot \left[\frac{GJ}{ma^2} \right] = 8.5$	$\therefore \phi = -0.07961$
$\phi'' \cdot \left[\frac{GJ}{m} \right] = 0$	$\therefore \phi'' = 0$
$\phi' \cdot \left[\frac{GJ}{m} \cdot \frac{2}{a} \right] = 1.9$	$\therefore \phi' = -0.0004177$
$\phi''' \cdot \left[\frac{GJa}{m} \right] = .9$	$\therefore \phi''' = -8.7229 \times 10^{-7}$

2) TORSIONAL LOAD 2: $m = .5 \text{ k-in/in}$ FROM 0" TO 32.4"

USE CASE 10, $\alpha = .3$

$$\begin{aligned} \text{AT SUPPORT: } \phi \cdot \left[\frac{GJ}{ma^2} \right] &= 0 & \therefore \phi &= 0 \\ \phi'' \cdot \left[\frac{GJ}{m} \right] &= .72 & \therefore \phi'' &= .00003716 \\ \phi' \cdot \left[\frac{GJ}{m} \cdot \frac{2}{a} \right] &= 0 & \therefore \phi' &= 0 \\ \phi''' \cdot \left[\frac{GJ\alpha}{m} \right] &= -1.5 & \therefore \phi''' &= -.000003634' \end{aligned}$$

$$\begin{aligned} \text{AT .3L (32.4")}: \phi \cdot \left[\frac{GJ}{ma^2} \right] &= .27 & \therefore \phi &= .006322 \\ \phi'' \cdot \left[\frac{GJ}{m} \right] &= -.14 & \therefore \phi'' &= -.00000723 \\ \phi' \cdot \left[\frac{GJ}{m} \cdot \frac{2}{a} \right] &= .28 & \therefore \phi' &= .0001539 \\ \phi''' \cdot \left[\frac{GJ\alpha}{m} \right] &= .16 & \therefore \phi''' &= .000000387 \end{aligned}$$

$$\begin{aligned} \text{AT FREE END: } \phi \cdot \left[\frac{GJ}{ma^2} \right] &= .4 & \therefore \phi &= .009366 \\ \phi'' \cdot \left[\frac{GJ}{m} \right] &= 0 & \therefore \phi'' &= 0 \\ \phi' \cdot \left[\frac{GJ}{m} \cdot \frac{2}{a} \right] &= 0 & \therefore \phi' &= 0 \\ \phi''' \cdot \left[\frac{GJ\alpha}{m} \right] &= 0 & \therefore \phi''' &= 0 \end{aligned}$$

3) SUMMATION OF $\phi, \phi'', \phi', \phi'''$ FOR LOADS 1 AND 2

$$\begin{aligned} \text{AT SUPPORT: } \phi &= 0 & \text{AT FREE END: } \phi &= -.070244 \\ \phi'' &= -.00004542 & \phi'' &= 0 \\ \phi' &= 0 & \phi' &= -.0004177 \\ \phi''' &= 1.212 \times 10^{-6} & \phi''' &= -8.7229 \times 10^{-7} \end{aligned}$$

$$\begin{aligned} \text{AT .3L (32.4")}: \phi &= -.017098 \\ \phi'' &= -1.3423 \times 10^{-5} \\ \phi' &= -9.014 \times 10^{-4} \\ \phi''' &= 1.35621 \times 10^{-6} \end{aligned}$$

B. STRESS CALCULATIONS

1) TORSIONAL SHEAR STRESSES

$$\tau_t = G \pm \phi'$$

$$L_F = .501 \text{ in}, \quad L_W = .51 \text{ in}$$

$$\text{AT SUPPORT: } \tau_{tW} = (11200 \text{ ksi})(.51 \text{ in})(0) = 0 \text{ ksi}$$

$$\tau_{tF} = (11200 \text{ ksi})(.501 \text{ in})(0) = 0 \text{ ksi}$$

$$\text{AT .3L (32.4"): } \tau_{tW} = (11200 \text{ ksi})(.51 \text{ in})(-9.014 \times 10^{-4}) = -5.149 \text{ ksi}$$

$$\tau_{tF} = (11200 \text{ ksi})(.501 \text{ in})(-9.014 \times 10^{-4}) = -5.058 \text{ ksi}$$

$$\text{AT FREE END: } \tau_{tW} = (11200 \text{ ksi})(.51 \text{ in})(-.0004177) = -2.386 \text{ ksi}$$

$$\tau_{tF} = (11200 \text{ ksi})(.501 \text{ in})(-.0004177) = -2.344 \text{ ksi}$$

2) WARPING NORMAL STRESSES

$$\sigma_{ws} = E W_n \phi''$$

$$W_{n0} = 11.7 \text{ in}^2, \quad W_{n2} = 5.02 \text{ in}^2$$

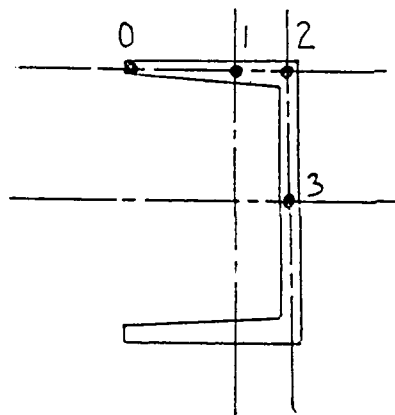

$$\text{AT SUPPORT: } \sigma_{ws_0} = (29000 \text{ ksi})(11.7 \text{ in}^2)(-.00004542) = -15.411 \text{ ksi}$$

$$\sigma_{ws_2} = (29000 \text{ ksi})(5.02 \text{ in}^2)(-.00004542) = -6.612 \text{ ksi}$$

$$\text{AT .3L (32.4'')}: \sigma_{ws_0} = (29000 \text{ ksi})(11.7 \text{ in}^2)(-1.3423 \times 10^{-5}) = -4.554 \text{ ksi}$$

$$\sigma_{ws_2} = (29000 \text{ ksi})(5.02 \text{ in}^2)(-1.3423 \times 10^{-5}) = -1.954 \text{ ksi}$$

$$\text{AT FREE END: } \sigma_{ws_0} = (29000 \text{ ksi})(11.7 \text{ in}^2)(0) = 0 \text{ ksi}$$

$$\sigma_{ws_2} = (29000 \text{ ksi})(5.02 \text{ in}^2)(0) = 0 \text{ ksi}$$

3) WARPING SHEAR STRESSES.

$$\tau_{ws} = -\frac{E S_w}{t} \phi'''$$

$$t_F = .501 \text{ in}, t_w = .51 \text{ in}$$

$$S_{w_1} = 6.01 \text{ in}^4, S_{w_2} = 4.91 \text{ in}^4, S_{w_3} = 2.45 \text{ in}^4$$

$$\text{AT SUPPORT: } \tau_{w_1} = -\frac{(29000 \text{ ksi})(6.01 \text{ in}^4)}{(.501 \text{ in})} (1.212 \times 10^{-6}) = -.422 \text{ ksi}$$

$$\tau_{w_2} = -\frac{(29000 \text{ ksi})(4.91 \text{ in}^4)}{(.501 \text{ in})} (1.212 \times 10^{-6}) = -.344 \text{ ksi}$$

$$\tau_{w_3} = -\frac{(29000 \text{ ksi})(2.45 \text{ in}^4)}{(.51 \text{ in})} (1.212 \times 10^{-6}) = -.169 \text{ ksi}$$

$$\text{AT .3L (32.4'')}: \tau_{w_1} = -\frac{(29000 \text{ ksi})(6.01 \text{ in}^4)}{(.501 \text{ in})} (1.35621 \times 10^{-6}) = -.472 \text{ ksi}$$

$$\tau_{w_2} = -\frac{(29000 \text{ ksi})(4.91 \text{ in}^4)}{(.501 \text{ in})} (1.35621 \times 10^{-6}) = -.385 \text{ ksi}$$

$$\tau_{w_3} = -\frac{(29000 \text{ ksi})(2.45 \text{ in}^4)}{(.51 \text{ in})} (1.35621 \times 10^{-6}) = -.189 \text{ ksi}$$

$$\text{AT FREE END: } \tau_{w_1} = -\frac{(29000 \text{ ksi})(6.01 \text{ in}^4)}{(.501 \text{ in})} (-8.7229 \times 10^{-7}) = .303 \text{ ksi}$$

$$\tau_{w_2} = -\frac{(29000 \text{ ksi})(4.91 \text{ in}^4)}{(.501 \text{ in})} (-8.7229 \times 10^{-7}) = .248 \text{ ksi}$$

$$\tau_{w_3} = -\frac{(29000 \text{ ksi})(2.45 \text{ in}^4)}{(.51 \text{ in})} (-8.7229 \times 10^{-7}) = .122 \text{ ksi}$$

HAND - CALCULATIONS
FOR PROBLEM 11

BEAM SELECTED: C5x9
END CONDITIONS: FIXED-FREE

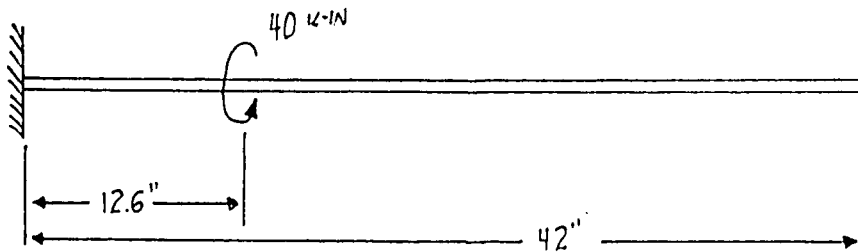

SHEAR & MOMENT DIAGRAMS

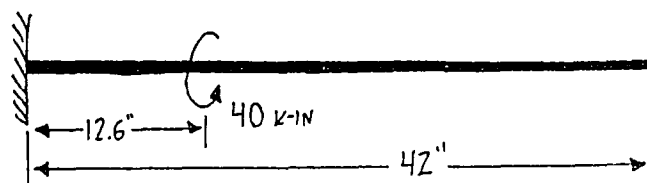

NO PLANE BENDING LOADS OR STRESSES

TORSION:

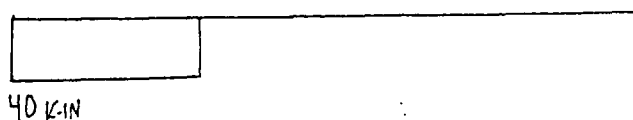

C5x9 DIMENSIONS & PROPERTIES

$A = 2.64 \text{ in}^2$	$I_y = .632 \text{ in}^4$	$W_{n0} = 2.65 \text{ in}^2$	$Q_F = 1.21 \text{ in}^3$
$d = 5.0 \text{ in}$	$S_x = 3.56 \text{ in}^3$	$W_{n2} = 1.38 \text{ in}^2$	$Q_U = 2.22 \text{ in}^3$
$b_F = 1.885 \text{ in}$	$S_y = .45 \text{ in}^3$	$S_{w1} = .48 \text{ in}^4$	$E = 29000 \text{ ksi}$
$t_w = .325 \text{ in}$	$J = .109 \text{ in}^4$	$S_{w2} = .35 \text{ in}^4$	$G = 11200 \text{ ksi}$
$t_F = .320 \text{ in}$	$C_w = 2.93 \text{ in}^6$	$S_{w3} = .175 \text{ in}^4$	
$I_x = 8.9 \text{ in}^4$	$a = 8.33 \text{ in}$		

TORSIONAL STRESSES

A. TORSIONAL FUNCTIONS

$$\text{USE } L/a = 42''/8.33'' = 5.04$$

1) TORSIONAL LOAD 1: $M = 40 \text{ k-in}$ AT $12.6''$

USE CASE 9, $\alpha = .3$

$$\begin{array}{ll} \text{AT SUPPORT: } \phi \cdot \left[\frac{GJ}{Ma} \right] = 0 & \therefore \phi = 0 \\ \phi'' \cdot \left[\frac{GJa}{M} \right] = .75 & \therefore \phi'' = .002950 \\ \phi' \cdot \left[\frac{GJ}{M} \right] = 0 & \therefore \phi' = 0 \\ \phi''' \cdot \left[\frac{GJa^2}{M} \right] = -1.0 & \therefore \phi''' = -.000472 \end{array}$$

$$\begin{array}{ll} \text{AT .3L (12.6'')}: \phi \cdot \left[\frac{GJ}{Ma} \right] = .42 & \therefore \phi = .114633 \\ \phi'' \cdot \left[\frac{GJa}{M} \right] = -.29 & \therefore \phi'' = -.001141 \\ \phi' \cdot \left[\frac{GJ}{M} \right] = .30 & \therefore \phi' = .009830 \\ \phi''' \cdot \left[\frac{GJa^2}{M} \right] = -.70 & \therefore \phi''' = -.000331 \end{array}$$

$$\begin{array}{ll} \text{AT FREE END: } \phi \cdot \left[\frac{GJ}{Ma} \right] = .72 & \therefore \phi = .196514 \\ \phi'' \cdot \left[\frac{GJa}{M} \right] = 0 & \therefore \phi'' = 0 \\ \phi' \cdot \left[\frac{GJ}{M} \right] = .02 & \therefore \phi' = .000655 \\ \phi''' \cdot \left[\frac{GJa^2}{M} \right] = .02 & \therefore \phi''' = .00000944 \end{array}$$

B. STRESS CALCULATIONS

1) TORSIONAL SHEAR STRESSES

$$\tau_t = G t \phi'$$

$$t_F = .32 \text{ in}, t_W = .325 \text{ in}$$

$$\begin{array}{l} \text{AT SUPPORT: } \tau_{tW} = (11200 \text{ ksi})(.325 \text{ in})(0) = 0 \text{ ksi} \\ \tau_{tF} = (11200 \text{ ksi})(.32 \text{ in})(0) = 0 \text{ ksi} \end{array}$$

$$\text{AT .3L (12.6")}: \tau_{tw} = (11200 \text{ ksi})(.325 \text{ in})(.009830) = 35.781 \text{ ksi}$$

$$\tau_{tf} = (11200 \text{ ksi})(.32 \text{ in})(.009830) = 35.231 \text{ ksi}$$

$$\text{AT FREE END}: \tau_{tw} = (11200 \text{ ksi})(.325 \text{ in})(.000655) = 2.384 \text{ ksi}$$

$$\tau_{tf} = (11200 \text{ ksi})(.32 \text{ in})(.000655) = 2.348 \text{ ksi}$$

2) WARPING NORMAL STRESSES

$$\sigma_{ws} = E W_n \phi''$$

$$W_{n0} = 2.65 \text{ in}^2, W_{n2} = 1.38 \text{ in}^2$$

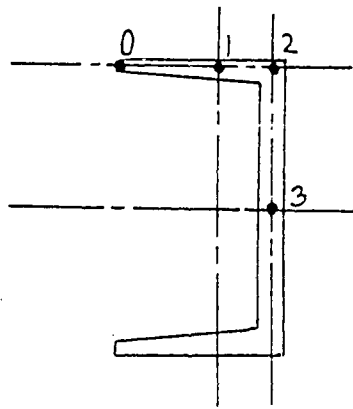

$$\text{AT SUPPORT}: \sigma_{ws_0} = (29000 \text{ ksi})(2.65 \text{ in}^2)(.002950) = 226.708 \text{ ksi}$$

$$\sigma_{ws_2} = (29000 \text{ ksi})(1.38 \text{ in}^2)(.002950) = 118.059 \text{ ksi}$$

$$\text{AT .3L (12.6")}: \sigma_{ws_0} = (29000 \text{ ksi})(2.65 \text{ in}^2)(-.001141) = -87.686 \text{ ksi}$$

$$\sigma_{ws_2} = (29000 \text{ ksi})(1.38 \text{ in}^2)(-.001141) = -45.653 \text{ ksi}$$

$$\text{AT FREE END}: \sigma_{ws_0} = (29000 \text{ ksi})(2.65 \text{ in}^2)(0) = 0 \text{ ksi}$$

$$\sigma_{ws_2} = (29000 \text{ ksi})(1.38 \text{ in}^2)(0) = 0 \text{ ksi}$$

3) WARPING SHEAR STRESSES

$$\tau_{ws} = -\frac{E S_w}{t} \phi''' \quad \begin{array}{l} t_F = .32 \text{ in}, t_W = .325 \text{ in} \\ S_{w_1} = .48 \text{ in}^4, S_{w_2} = .35 \text{ in}^4, S_{w_3} = .175 \text{ in}^4 \end{array}$$

AT SUPPORT: $\tau_{w_1} = \frac{-(29000 \text{ ksi})(.48 \text{ in}^4)}{(.32 \text{ in})} (-.000472) = 20.532 \text{ ksi}$

$$\tau_{w_2} = \frac{-(29000 \text{ ksi})(.35 \text{ in}^4)}{(.32 \text{ in})} (-.000472) = 14.971 \text{ ksi}$$

$$\tau_{w_3} = \frac{-(29000 \text{ ksi})(.175 \text{ in}^4)}{(.325 \text{ in})} (-.000472) = 7.370 \text{ ksi}$$

AT .3L (12.6"): $\tau_{w_1} = \frac{-(29000 \text{ ksi})(.48 \text{ in}^4)}{(.32 \text{ in})} (-.000331) = 14.399 \text{ ksi}$

$$\tau_{w_2} = \frac{-(29000 \text{ ksi})(.35 \text{ in}^4)}{(.32 \text{ in})} (-.000331) = 10.337 \text{ ksi}$$

$$\tau_{w_3} = \frac{-(29000 \text{ ksi})(.175 \text{ in}^4)}{(.325 \text{ in})} (-.000331) = 5.169 \text{ ksi}$$

AT FREE END: $\tau_{w_1} = \frac{-(29000 \text{ ksi})(.48 \text{ in}^4)}{(.32 \text{ in})} (.00000944) = -.411 \text{ ksi}$

$$\tau_{w_2} = \frac{-(29000 \text{ ksi})(.35 \text{ in}^4)}{(.32 \text{ in})} (.00000944) = -.299 \text{ ksi}$$

$$\tau_{w_3} = \frac{-(29000 \text{ ksi})(.175 \text{ in}^4)}{(.325 \text{ in})} (.00000944) = -.147 \text{ ksi}$$

HAND-CALCULATIONS
FOR PROBLEM 12

BEAM SELECTED: MC 18x42
END CONDITIONS: FIXED-FREE

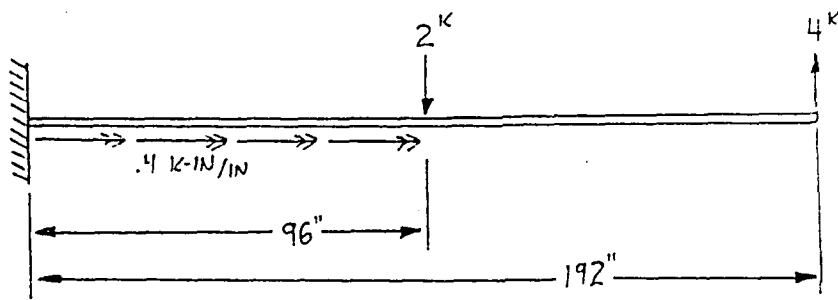

SHEAR & MOMENT DIAGRAMS

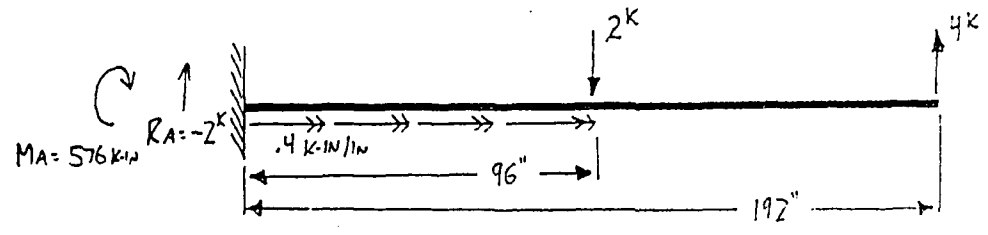

SHEAR:

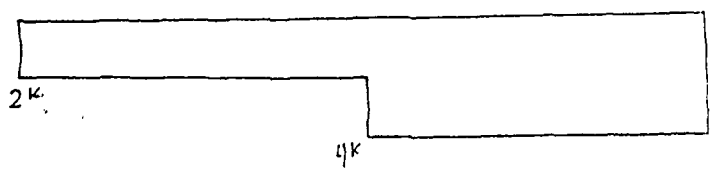

MOMENT:

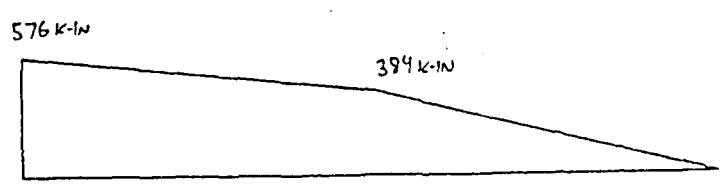

TORSION:

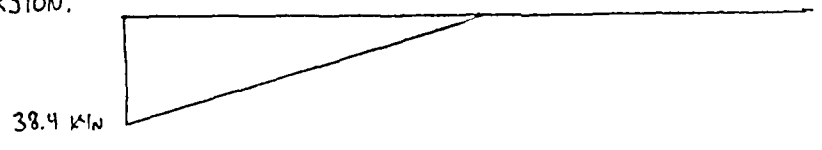

MC 18x42 DIMENSIONS & PROPERTIES

$A = 12.6 \text{ in}^2$	$I_y = 14.4 \text{ in}^4$	$W_{n0} = 22.0 \text{ in}^2$	$Q_F = 19.7 \text{ in}^3$
$d = 18 \text{ in}$	$S_x = 61.6 \text{ in}^3$	$W_{n2} = 10.4 \text{ in}^2$	$Q_w = 37.9 \text{ in}^3$
$b_f = 3.95 \text{ in}$	$S_y = 4.69 \text{ in}^3$	$S_{w1} = 17.4 \text{ in}^4$	$E = 29000 \text{ ksi}$
$t_w = .45 \text{ in}$	$J = 1.23 \text{ in}^4$	$S_{w2} = 13.5 \text{ in}^4$	$G = 11200 \text{ ksi}$
$t_f = .625 \text{ in}$	$C_w = 852 \text{ in}^6$	$S_{w3} = 6.76 \text{ in}^4$	
$I_x = 554 \text{ in}^4$	$a = 42.3 \text{ in}$		

PLANE BENDING STRESSES

A. LONGITUDINAL BENDING STRESSES

$$\sigma_B = M_B / S_x$$

$$\text{AT SUPPORT: } \sigma_B = 576 \text{ k-in} / 61.6 \text{ in}^3 = 9.351 \text{ ksi}$$

$$\text{AT .5L (96")}: \sigma_B = 384 \text{ k-in} / 61.6 \text{ in}^3 = 6.234 \text{ ksi}$$

$$\text{AT FREE END: } \sigma_B = 0 \text{ ksi}$$

B. MAXIMUM WEB SHEAR STRESSES

$$\tau_w = VQ_w / I_{tw}$$

$$\text{AT SUPPORT: } \tau_w = (-2 \text{ k})(37.9 \text{ in}^3) / (554 \text{ in}^4)(.45 \text{ in}) = -.3041 \text{ ksi}$$

$$\text{AT .5L (96")}: \tau_w = (-2 \text{ k})(37.9 \text{ in}^3) / (554 \text{ in}^4)(.45 \text{ in}) = -.3041 \text{ ksi}$$

$$\text{AT FREE END: } \tau_w = (-4 \text{ k})(37.9 \text{ in}^3) / (554 \text{ in}^4)(.45 \text{ in}) = -.6081 \text{ ksi}$$

C. MAXIMUM FLANGE SHEAR STRESSES

$$\tau_f = VQ_f / I_{tf}$$

$$\text{AT SUPPORT: } \tau_f = (-2 \text{ k})(19.7 \text{ in}^3) / (554 \text{ in}^4)(.625 \text{ in}) = -.1138 \text{ ksi}$$

$$\text{AT .5L (96")}: \tau_F = (-2^k)(19.7 \text{ in}^3) / (554 \text{ in}^4)(.625 \text{ in}) = -.1138 \text{ ksi}$$

$$\text{AT FREE END}: \tau_F = (-4^k)(19.7 \text{ in}^3) / (554 \text{ in}^4)(.625 \text{ in}) = -.2276 \text{ ksi}$$

TORSIONAL STRESSES

A. TORSION FUNCTIONS

$$\text{USE } L/a = 192'' / 42.3'' = 4.54$$

1) TORSIONAL LOAD 1: $m = .4 \text{ k-in} / \text{in}$ FROM 0" TO 96"

USE CASE 10, $\alpha = .5$

$$\begin{array}{ll} \text{AT SUPPORT: } \phi \cdot \left[\frac{GJ}{ma^2} \right] = 0 & \therefore \phi = 0 \\ \phi'' \cdot \left[\frac{GJ}{m} \right] = 1.36 & \therefore \phi'' = .000039488 \\ \phi' \cdot \left[\frac{GJ}{m} \cdot \frac{2}{a} \right] = 0 & \therefore \phi' = 0 \\ \phi''' \cdot \left[\frac{GJa}{m} \right] = -2.25 & \therefore \phi''' = -1.544 \times 10^{-6} \end{array}$$

$$\begin{array}{ll} \text{AT .5L (96")}: \phi \cdot \left[\frac{GJ}{ma^2} \right] = .94 & \therefore \phi = .04884 \\ \phi'' \cdot \left[\frac{GJ}{m} \right] = -.26 & \therefore \phi'' = -7.5494 \times 10^{-6} \\ \phi' \cdot \left[\frac{GJ}{m} \cdot \frac{2}{a} \right] = .5 & \therefore \phi' = .00030706 \\ \phi''' \cdot \left[\frac{GJa}{m} \right] = .25 & \therefore \phi''' = 1.7161 \times 10^{-7} \end{array}$$

$$\begin{array}{ll} \text{AT FREE END: } \phi \cdot \left[\frac{GJ}{ma^2} \right] = 1.2 & \therefore \phi = .06234 \\ \phi'' \cdot \left[\frac{GJ}{m} \right] = 0 & \therefore \phi'' = 0 \\ \phi' \cdot \left[\frac{GJ}{m} \cdot \frac{2}{a} \right] = .1 & \therefore \phi' = .0000614 \\ \phi''' \cdot \left[\frac{GJa}{m} \right] = 0 & \therefore \phi''' = 0 \end{array}$$

2) TORSIONAL LOAD 2: DUE TO ECCENTRICITY OF CONCENTRATED LOAD ($P = 2^k \downarrow$) THROUGH CHANNEL SHEAR CENTER

$$e_o = E_o + \bar{x} - t_w/2 \quad E_o = 1.19 \text{ in}, \bar{x} = .877 \text{ in}, t_w = .45 \text{ in}$$

$$= 1.19 \text{ in} + .877 \text{ in} - \frac{.45 \text{ in}}{2}$$

$$= 1.84 \text{ in}$$

$$\therefore M = P e_o = (2^k)(1.84 \text{ in}) = 3.68 \text{ k-in} \rightarrow \text{AT } 96'' (.5L)$$

USE CASE 9, $\alpha = .5$

AT SUPPORT:

$$\phi \cdot \left[\frac{GJ}{Ma} \right] = 0 \quad \therefore \phi = 0$$

$$\phi'' \cdot \left[\frac{GJa}{M} \right] = .88 \quad \therefore \phi'' = -5.5573 \times 10^{-6}$$

$$\phi' \cdot \left[\frac{GJ}{M} \right] = 0 \quad \therefore \phi' = 0$$

$$\phi''' \cdot \left[\frac{GJa^2}{M} \right] = -1.0 \quad \therefore \phi''' = 1.4929 \times 10^{-7}$$

AT .5L (96''):

$$\phi \cdot \left[\frac{GJ}{Ma} \right] = .96 \quad \therefore \phi = -.01085$$

$$\phi'' \cdot \left[\frac{GJa}{M} \right] = -.4 \quad \therefore \phi'' = 2.5261 \times 10^{-6}$$

$$\phi' \cdot \left[\frac{GJ}{M} \right] = .4 \quad \therefore \phi' = -1.0685 \times 10^{-4}$$

$$\phi''' \cdot \left[\frac{GJa^2}{M} \right] = -.6 \quad \therefore \phi''' = 8.9577 \times 10^{-8}$$

AT FREE END:

$$\phi \cdot \left[\frac{GJ}{Ma} \right] = 1.36 \quad \therefore \phi = -.01537$$

$$\phi'' \cdot \left[\frac{GJa}{M} \right] = 0 \quad \therefore \phi'' = 0$$

$$\phi' \cdot \left[\frac{GJ}{M} \right] = .08 \quad \therefore \phi' = -2.1370 \times 10^{-5}$$

$$\phi''' \cdot \left[\frac{GJa^2}{M} \right] = .08 \quad \therefore \phi''' = -1.1944 \times 10^{-8}$$

3) TORSIONAL LOAD 3 : DUE TO ECCENTRICITY OF CONCENTRATED LOAD ($P=4k \uparrow$) THROUGH CHANNEL SHEAR CENTER.

$$M = Pe_0 = (4k)(1.84in) = 7.36 k\cdot in \quad \text{---} \quad \text{AT } 192'' \text{ (iL)}$$

USE CASE 9, $\alpha=1.0$

AT SUPPORT :

$$\begin{aligned} \phi \cdot \left[\frac{GJ}{Ma} \right] &= 0 & \therefore \phi &= 0 \\ \phi'' \cdot \left[\frac{GJ}{M} \cdot 5a \right] &= 5.0 & \therefore \phi'' &= 1.2630 \times 10^{-5} \\ \phi' \cdot \left[\frac{GJ}{M} \right] &= 0 & \therefore \phi' &= 0 \\ \phi''' \cdot \left[\frac{GJa^2}{M} \right] &= -1.0 & \therefore \phi''' &= -2.9859 \times 10^{-7} \end{aligned}$$

AT .5L (96'') :

$$\begin{aligned} \phi \cdot \left[\frac{GJ}{Ma} \right] &= 1.25 & \therefore \phi &= .02825 \\ \phi'' \cdot \left[\frac{GJ}{M} \cdot 5a \right] &= .6 & \therefore \phi'' &= 1.5156 \times 10^{-6} \\ \phi' \cdot \left[\frac{GJ}{M} \right] &= .9 & \therefore \phi' &= 4.8084 \times 10^{-4} \\ \phi''' \cdot \left[\frac{GJa^2}{M} \right] &= -.10 & \therefore \phi''' &= -2.9859 \times 10^{-8} \end{aligned}$$

AT FREE END :

$$\begin{aligned} \phi \cdot \left[\frac{GJ}{Ma} \right] &= 3.25 & \therefore \phi &= .07345 \\ \phi'' \cdot \left[\frac{GJ}{M} \cdot 5a \right] &= 0 & \therefore \phi'' &= 0 \\ \phi' \cdot \left[\frac{GJ}{M} \right] &= .98 & \therefore \phi' &= 5.2358 \times 10^{-4} \\ \phi''' \cdot \left[\frac{GJa^2}{M} \right] &= -.02 & \therefore \phi''' &= -5.9718 \times 10^{-9} \end{aligned}$$

4) SUMMATION OF $\phi, \phi'', \phi', \phi'''$ FOR LOADS 1, 2, AND 3

AT SUPPORT :

$$\begin{aligned} \phi &= 0 \\ \phi'' &= .00004656 \\ \phi' &= 0 \\ \phi''' &= -1.6933 \times 10^{-6} \end{aligned}$$

$$\begin{aligned} \text{AT .5L (96")}: \quad \phi &= .06624 \\ \phi'' &= -3.5077 \times 10^{-6} \\ \phi' &= .0006811 \\ \phi''' &= 2.31328 \times 10^{-7} \end{aligned}$$

$$\begin{aligned} \text{AT FREE END:} \quad \phi &= .12042 \\ \phi'' &= 0 \\ \phi' &= .000056361 \\ \phi''' &= -1.7916 \times 10^{-8} \end{aligned}$$

B. STRESS CALCULATIONS

D) TORSIONAL SHEAR STRESSES

$$\tau_t = G t \phi'$$

$$t_F = .625 \text{ in}, \quad t_W = .45 \text{ in}$$

$$\begin{aligned} \text{AT SUPPORT:} \quad \tau_{tW} &= (11200 \text{ ksi})(.45 \text{ in})(0) = 0 \text{ ksi} \\ \tau_{tF} &= (11200 \text{ ksi})(.625 \text{ in})(0) = 0 \text{ ksi} \end{aligned}$$

$$\begin{aligned} \text{AT .5L (96")}: \quad \tau_{tW} &= (11200 \text{ ksi})(.45 \text{ in})(.0006811) = 3.433 \text{ ksi} \\ \tau_{tF} &= (11200 \text{ ksi})(.625 \text{ in})(.0006811) = 4.768 \text{ ksi} \end{aligned}$$

$$\begin{aligned} \text{AT FREE END:} \quad \tau_{tW} &= (11200 \text{ ksi})(.45 \text{ in})(.000056361) = 2.841 \text{ ksi} \\ \tau_{tF} &= (11200 \text{ ksi})(.625 \text{ in})(.000056361) = 3.945 \text{ ksi} \end{aligned}$$

2) WARPING NORMAL STRESSES

$$\sigma_{ws} = E' W_n \phi''$$

$$W_{n0} = 22 \text{ in}^2, W_{n2} = 10.4 \text{ in}^2$$

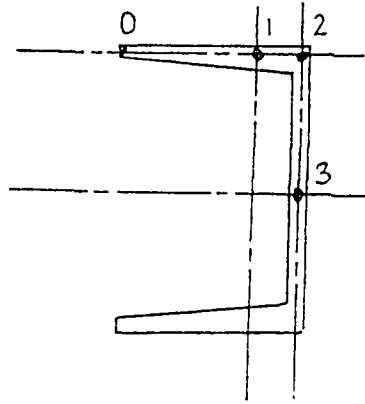

$$\begin{aligned} \text{AT SUPPORT: } \sigma_{w0} &= (29000 \text{ ksi})(22 \text{ in}^2)(.00004656) = 29.705 \text{ ksi} \\ \sigma_{w2} &= (29000 \text{ ksi})(10.4 \text{ in}^2)(.00004656) = 14.042 \text{ ksi} \end{aligned}$$

$$\begin{aligned} \text{AT .5L (.96')}: \sigma_{w0} &= (29000 \text{ ksi})(22 \text{ in}^2)(-3.5077 \times 10^{-6}) = -2.238 \text{ ksi} \\ \sigma_{w2} &= (29000 \text{ ksi})(10.4 \text{ in}^2)(-3.5077 \times 10^{-6}) = -1.058 \text{ ksi} \end{aligned}$$

$$\begin{aligned} \text{AT FREE END: } \sigma_{w0} &= (29000 \text{ ksi})(22 \text{ in}^2)(0) = 0 \text{ ksi} \\ \sigma_{w2} &= (29000 \text{ ksi})(10.4 \text{ in}^2)(0) = 0 \text{ ksi} \end{aligned}$$

3) WARPING SHEAR STRESSES

$$\tau_{ws} = -\frac{E' S_w}{t} \phi'''$$

$$t_F = .625 \text{ in}, t_w = .45 \text{ in}$$

$$S_{w1} = 17.4 \text{ in}^4, S_{w2} = 13.5 \text{ in}^4, S_{w3} = 6.76 \text{ in}^4$$

$$\text{AT SUPPORT: } \tau_{ws1} = \frac{-(29000 \text{ ksi})(17.4 \text{ in}^4)}{(.625 \text{ in})} (-1.6933 \times 10^{-6}) = 1.367 \text{ ksi}$$

$$\tau_{ws2} = \frac{-(29000 \text{ ksi})(13.5 \text{ in}^4)}{(.625 \text{ in})} (-1.6933 \times 10^{-6}) = 1.061 \text{ ksi}$$

$$\tau_{ws3} = \frac{-(29000 \text{ ksi})(6.76 \text{ in}^4)}{(0.45 \text{ in})} (-1.6933 \times 10^{-6}) = .738 \text{ ksi}$$

AT .5L (96"):

$$\tau_{ws1} = \frac{-(29000 \text{ ksi})(17.4 \text{ in}^4)}{(0.625 \text{ in})} (2.31328 \times 10^{-7}) = -.187 \text{ ksi}$$

$$\tau_{ws2} = \frac{-(29000 \text{ ksi})(13.5 \text{ in}^4)}{(0.625 \text{ in})} (2.31328 \times 10^{-7}) = -.145 \text{ ksi}$$

$$\tau_{ws3} = \frac{-(29000 \text{ ksi})(6.76 \text{ in}^4)}{(0.45 \text{ in})} (2.31328 \times 10^{-7}) = -.101 \text{ ksi}$$

AT FREE END:

$$\tau_{ws1} = \frac{-(29000 \text{ ksi})(17.4 \text{ in}^4)}{(0.625 \text{ in})} (-1.7916 \times 10^{-8}) = .014 \text{ ksi}$$

$$\tau_{ws2} = \frac{-(29000 \text{ ksi})(13.5 \text{ in}^4)}{(0.625 \text{ in})} (-1.7916 \times 10^{-8}) = .011 \text{ ksi}$$

$$\tau_{ws3} = \frac{-(29000 \text{ ksi})(6.76 \text{ in}^4)}{(0.45 \text{ in})} (-1.7916 \times 10^{-8}) = .008 \text{ ksi}$$

APPENDIX B

TORSION ANALYSIS CASE CHARTS

from Steel Design File, Torsional
Analysis of Rolled Steel Sections

Bethlehem Steel Corporation, Bethlehem, PA
Copyright 1963

<u>Case Chart</u>	<u>End Conditions</u>	<u>Torsional Load Type</u>	<u>Load Location</u>
Case 3 ($\alpha = .1$)	Pinned-Pinned	Concentrated	.1L of member
Case 3 ($\alpha = .3$)	Pinned-Pinned	Concentrated	.3L of member
Case 6 ($\alpha = .5$)	Fixed-Fixed	Concentrated	.5L of member
Case 7	Fixed-Fixed	Distributed	Entire length
Case 9 ($\alpha = .3$)	Fixed-Free	Concentrated	.3L of member
Case 9 ($\alpha = .5$)	Fixed-Free	Concentrated	.5L of member
Case 9 ($\alpha = .7$)	Fixed-Free	Concentrated	.7L of member
Case 9 ($\alpha = 1.0$)	Fixed-Free	Concentrated	At free end
Case 10 ($\alpha = .3$)	Fixed-Free	Distributed	From 0 to .3L
Case 10 ($\alpha = .5$)	Fixed-Free	Distributed	From 0 to .5L
Case 10 ($\alpha = .7$)	Fixed-Free	Distributed	From 0 to .7L
Case 10 ($\alpha = 1.0$)	Fixed-Free	Distributed	Entire length
Case 12	Fixed-Pinned	Distributed	Entire Length

$\alpha = 0.1 \quad \phi', \phi''$

CASE 3

$\alpha = 0.1 \quad \phi', \phi''$

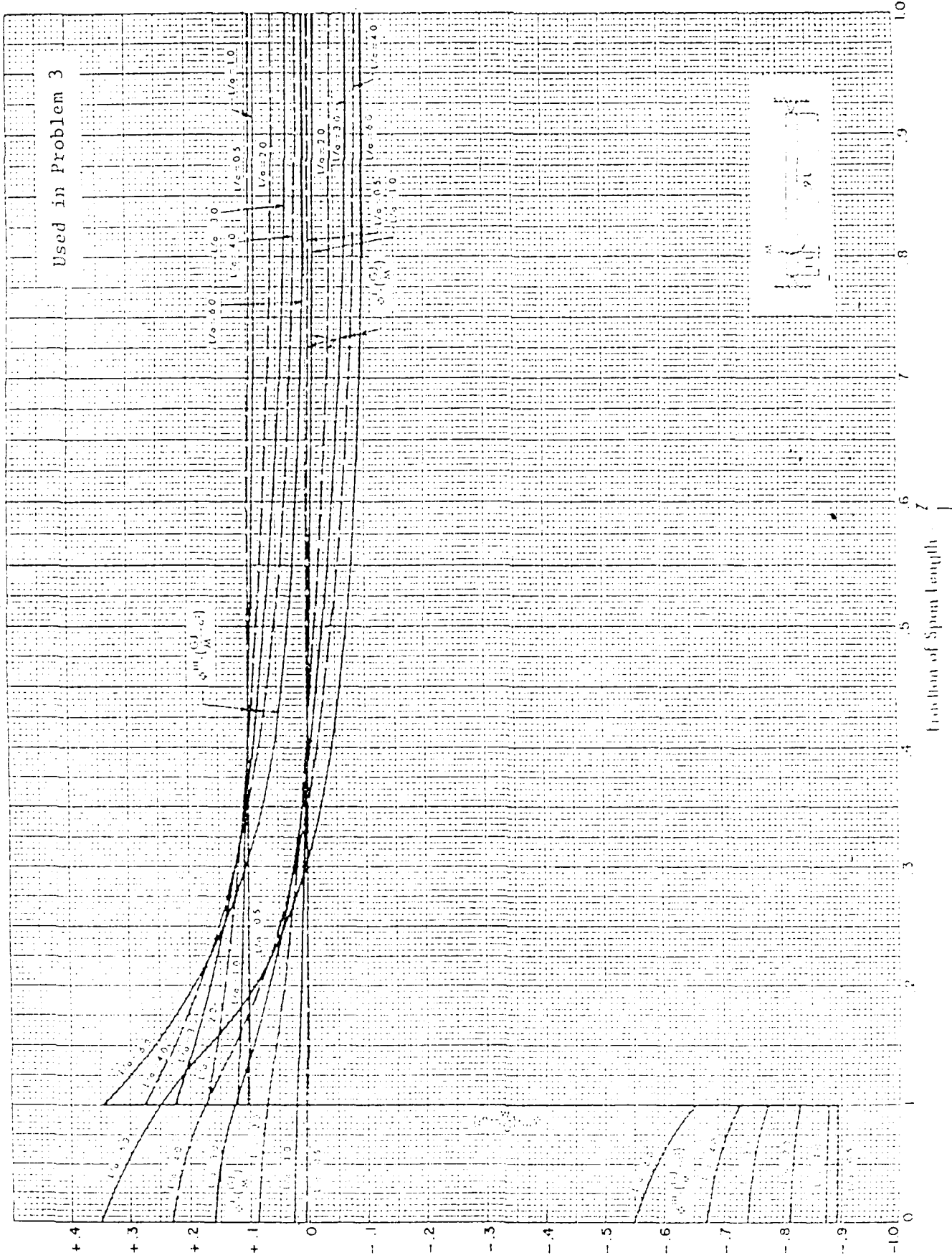

$\phi'''(z)$
and
 $\phi''(z)$

Case 3

$\alpha = 0.3 \quad \phi, \phi''$

CASE 3
 $\alpha = 0.3 \quad \phi, \phi''$

Used in Problem 3

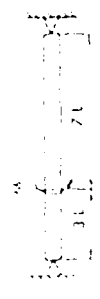
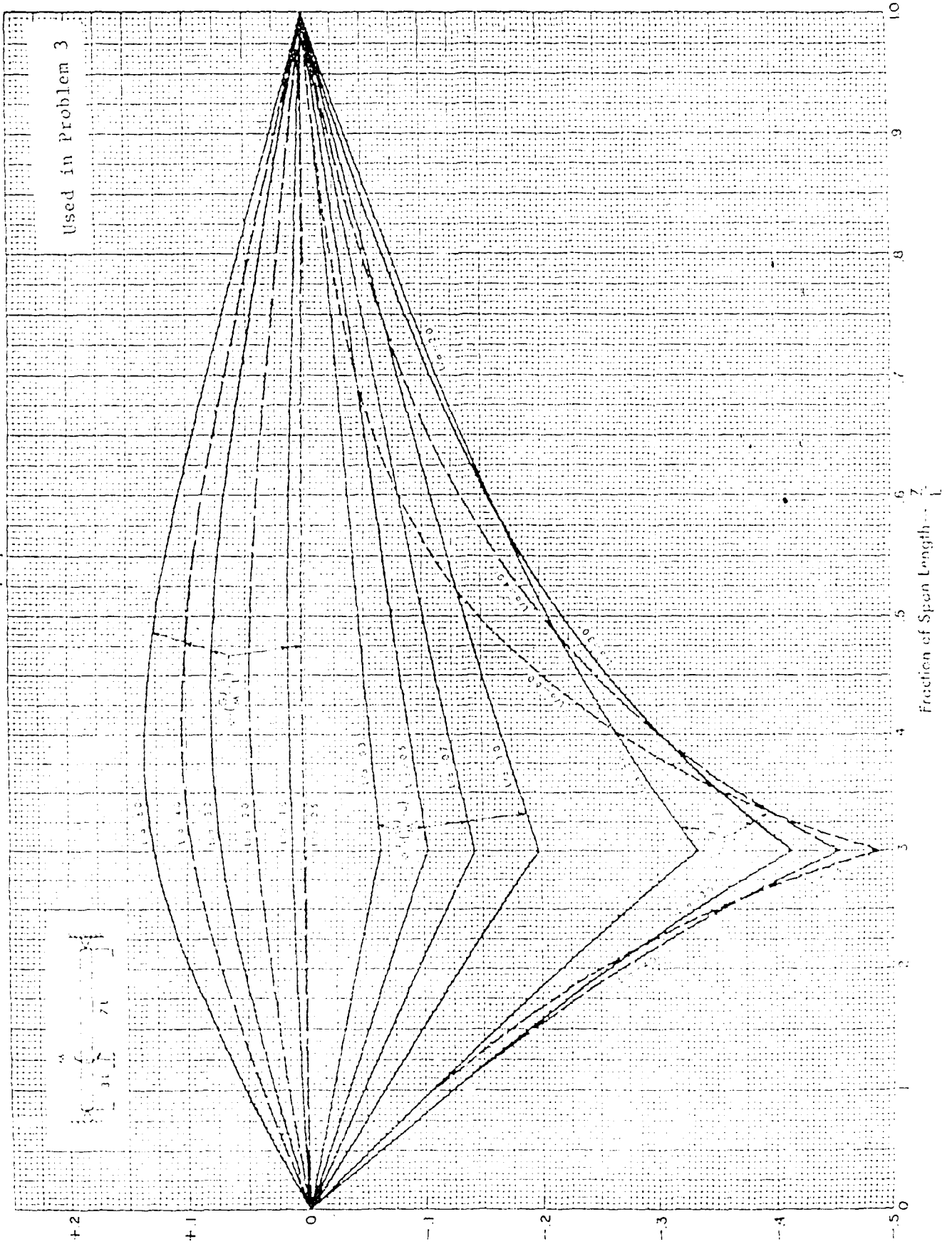

$\alpha = 0.3 \quad \phi', \phi'''$

CASE 3
 $\alpha = 0.3 \quad \phi', \phi'''$

Used in Problem 3

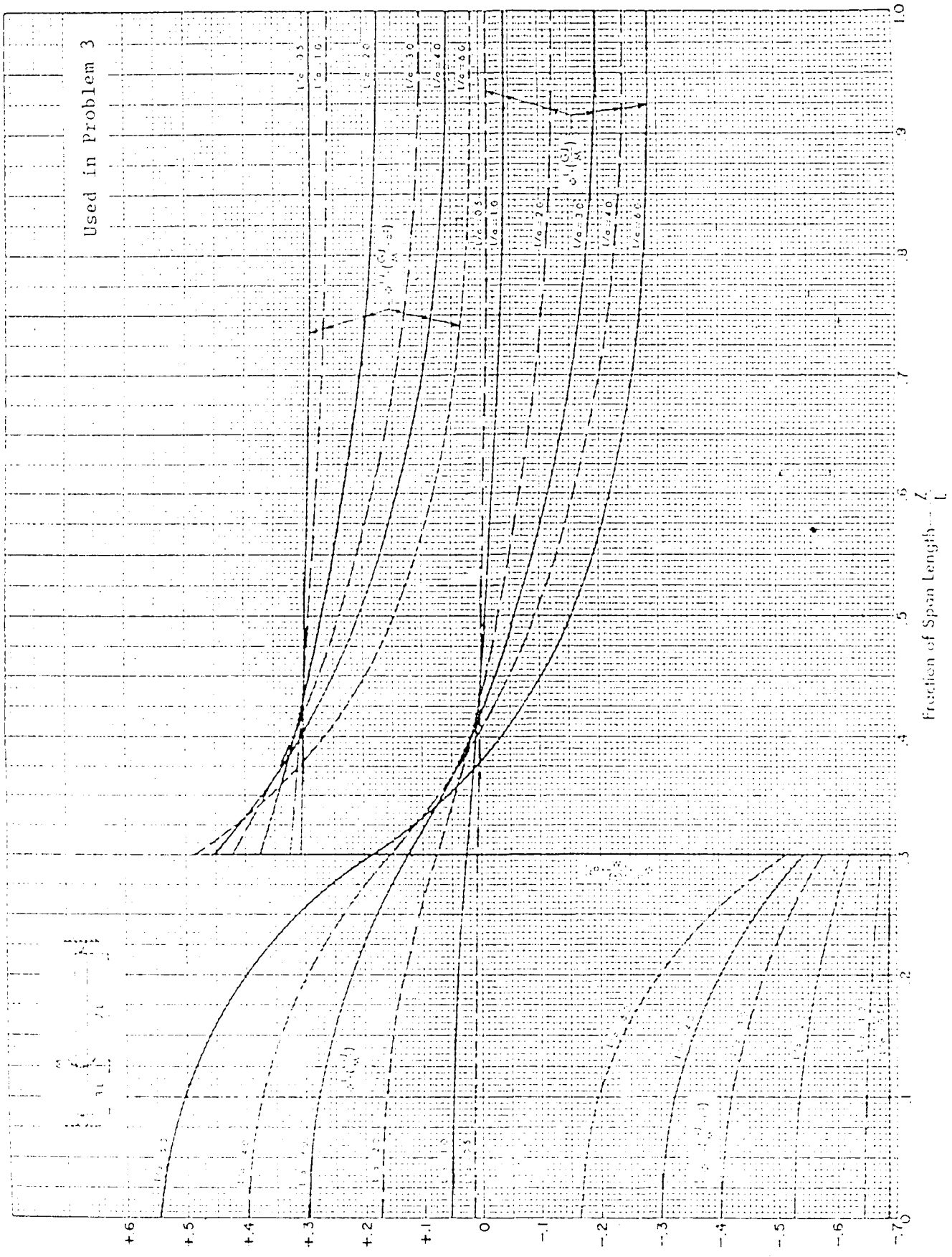

Normalized
 functions

Fraction of Span Length ξ

Case 6

$\alpha = 0.5 \quad \phi, \phi''$

CASE 6
 $\alpha = 0.5 \quad \phi, \phi''$

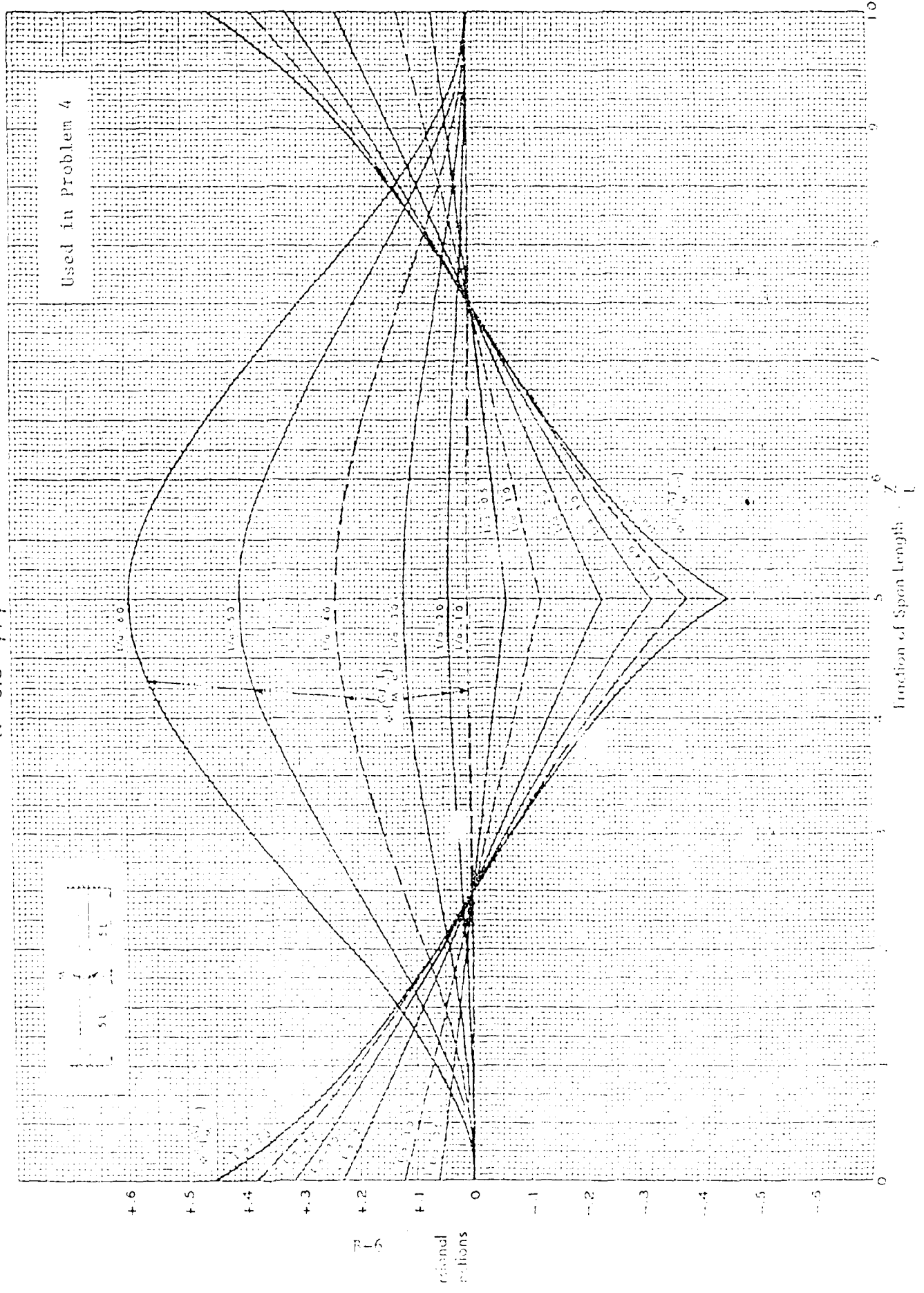

CASE 6
 $\alpha = 0.5 \phi', \phi''$

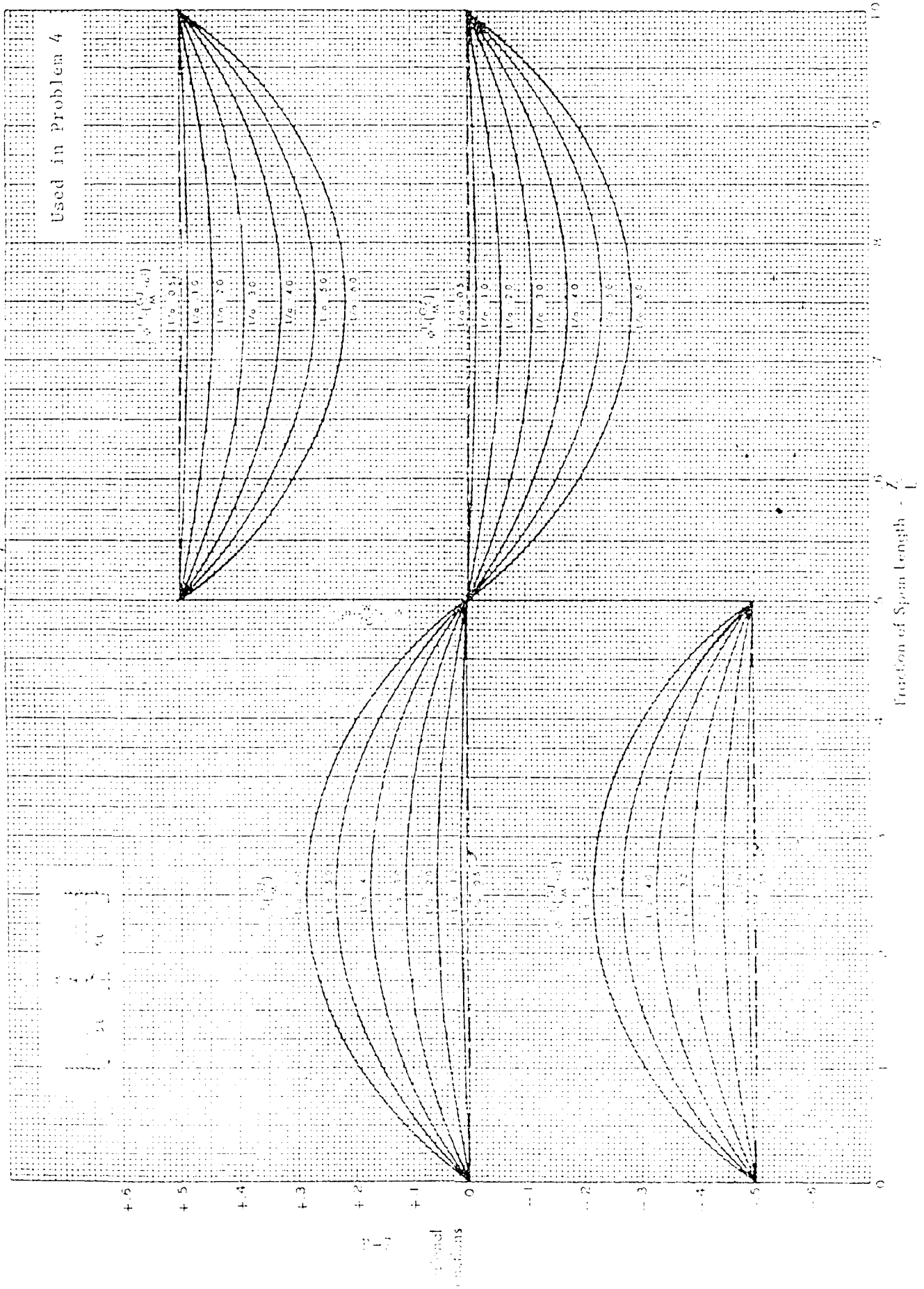

ϕ, ϕ''

CASE 7
 ϕ, ϕ''

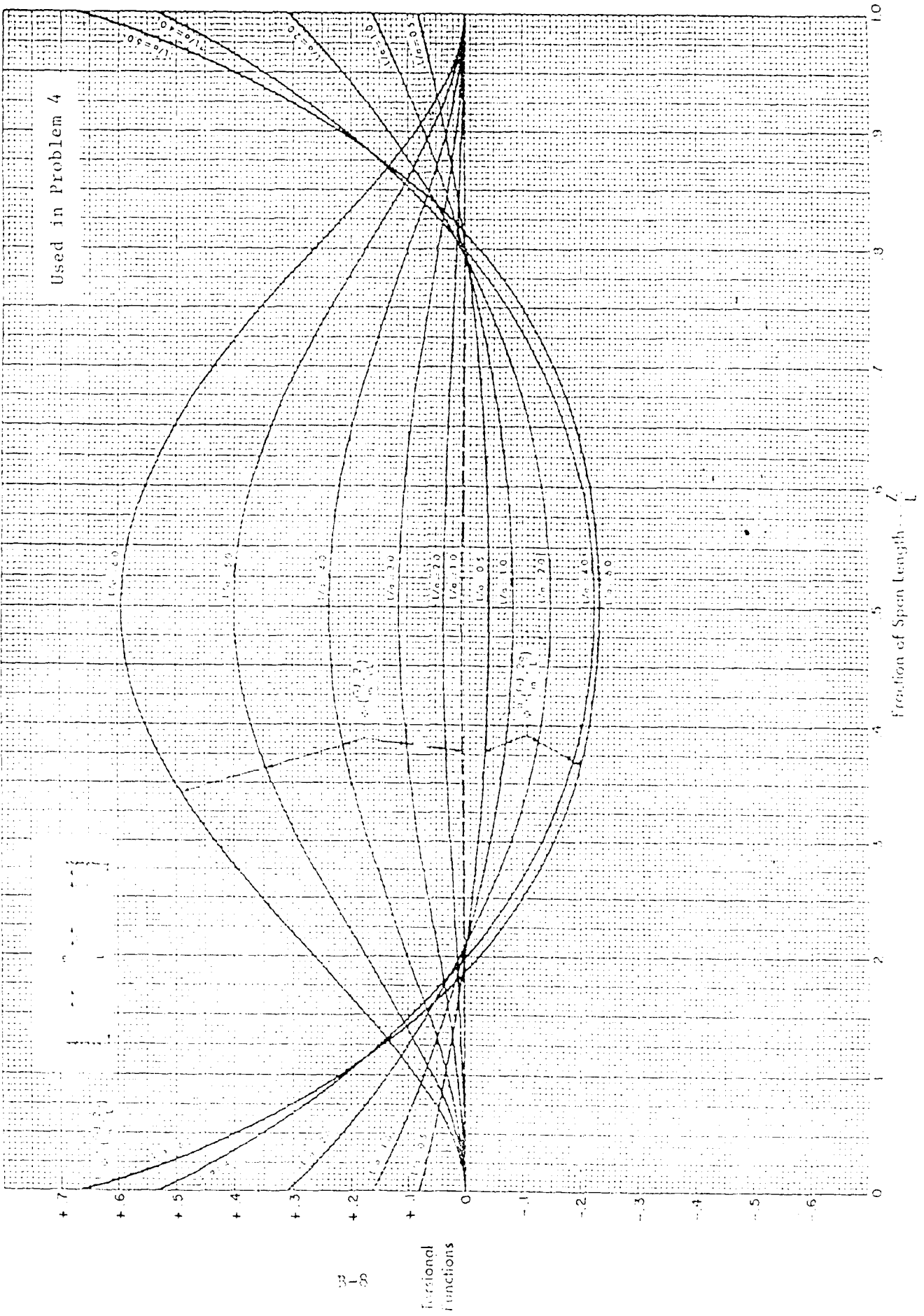

CASE 7
 ϕ', ϕ'''

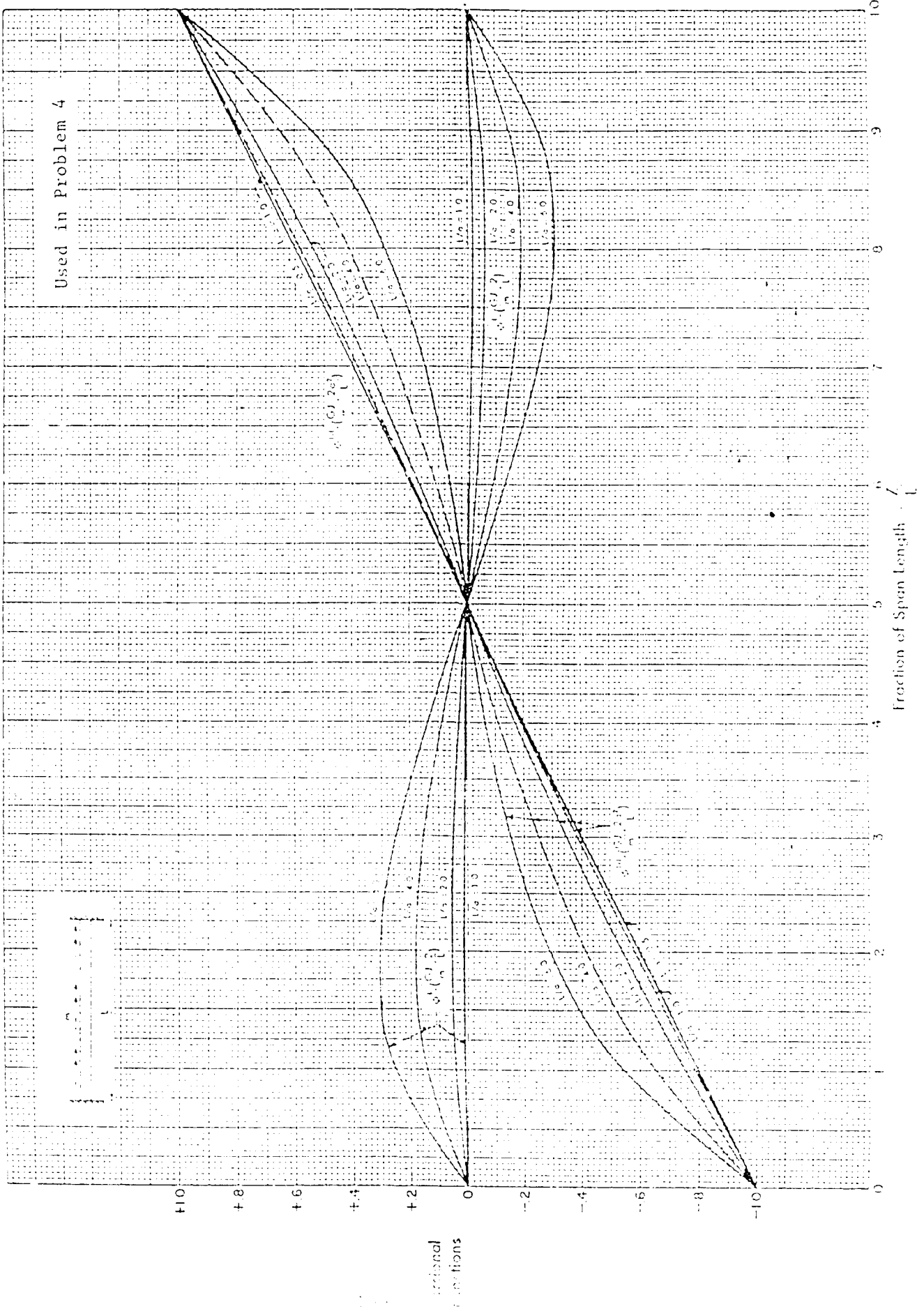

$\alpha = 0.3 \quad \phi', \phi'''$

CASE 9
 $\alpha = 0.3 \quad \phi', \phi'''$

Used in Problems 5, 7, 9 and 11

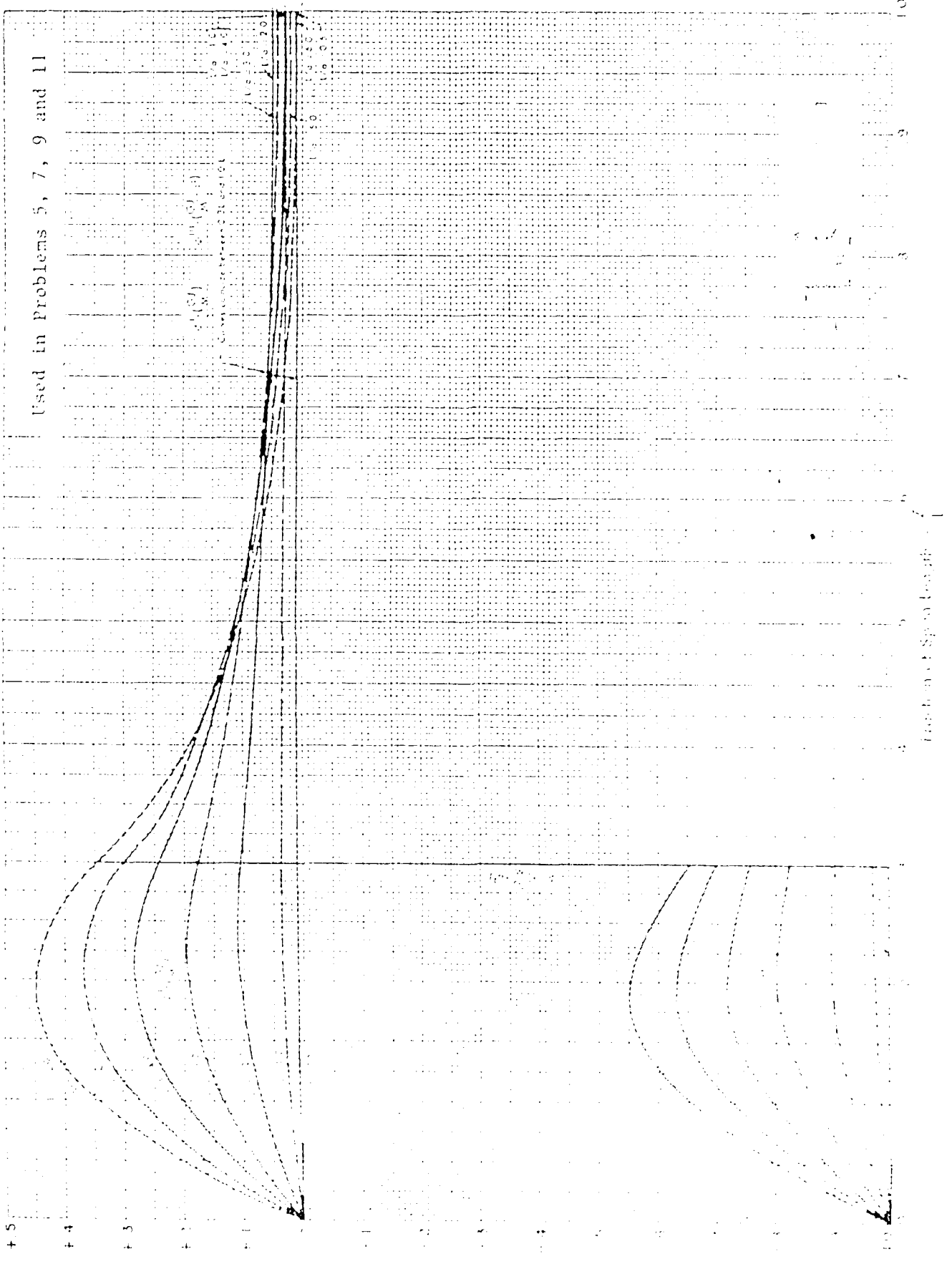

Case 9

$\alpha=0.5 \quad \phi, \phi''$

CASE 9
 $\alpha=0.5 \quad \phi, \phi''$

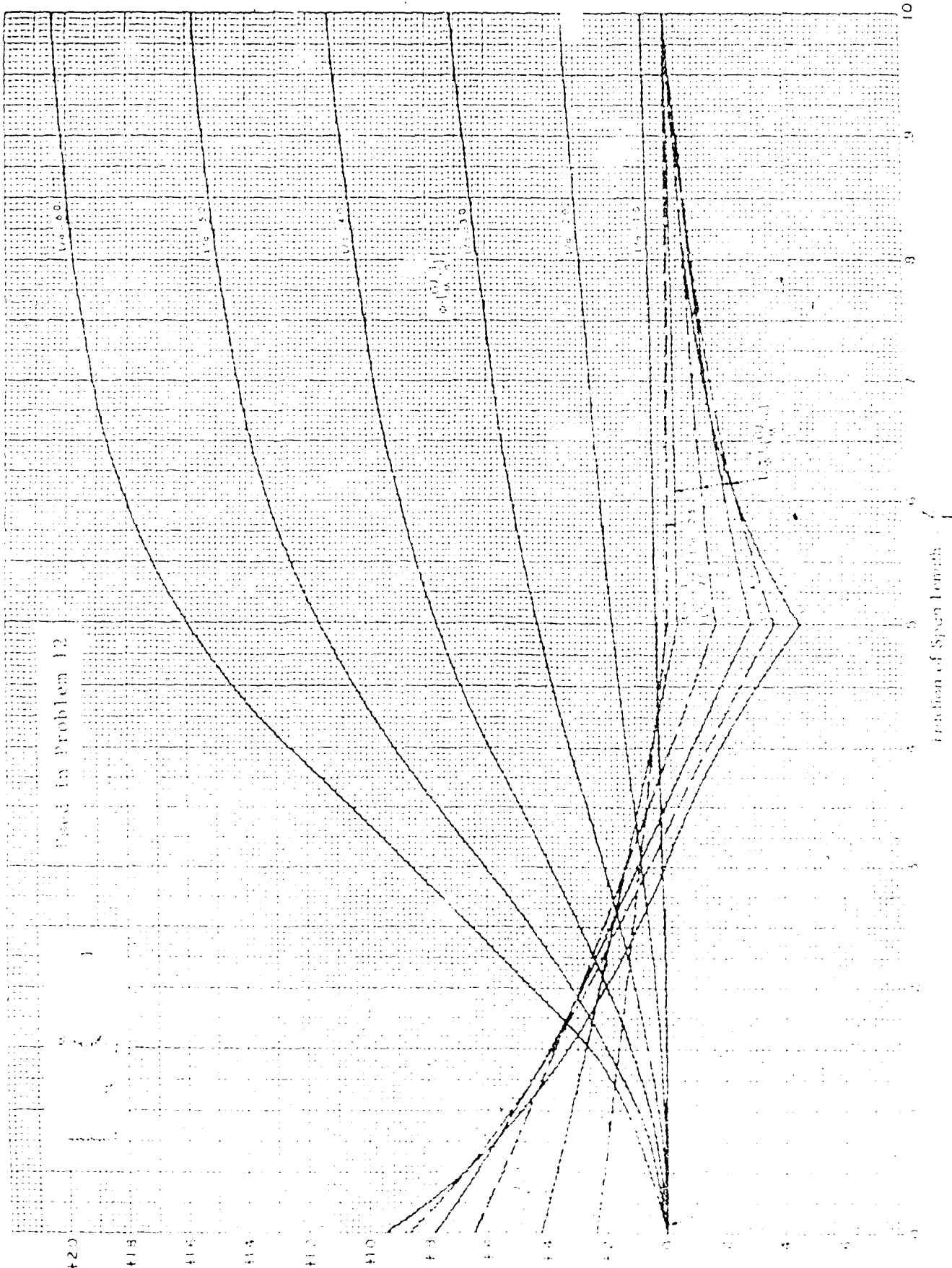

Used in Problem 12

CASE 9
 $\alpha = 0.5 \quad \phi', \phi''$

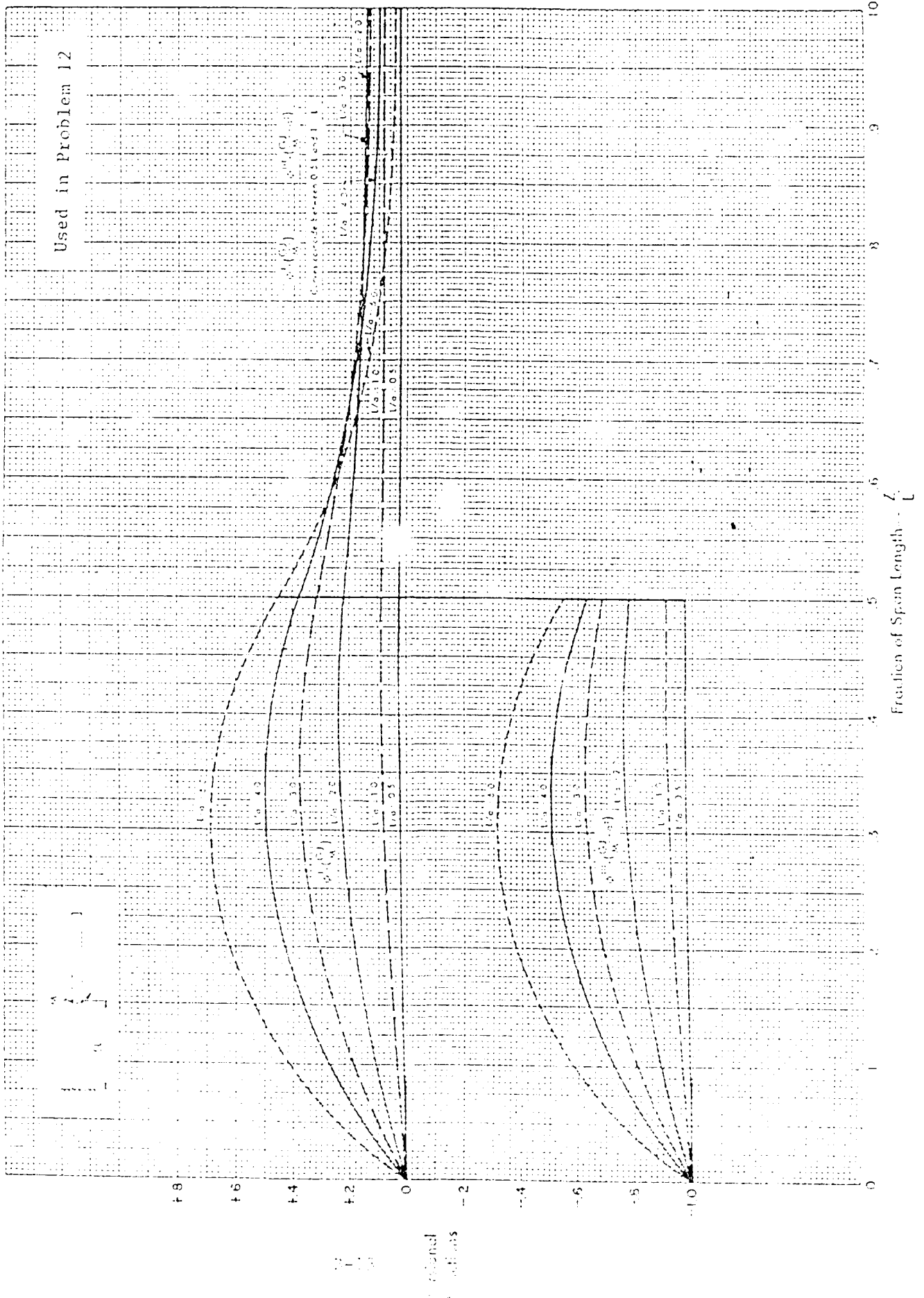

CASE 9
 $\alpha = 0.7$ ϕ' , ϕ'''

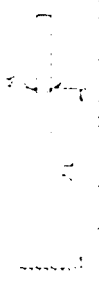
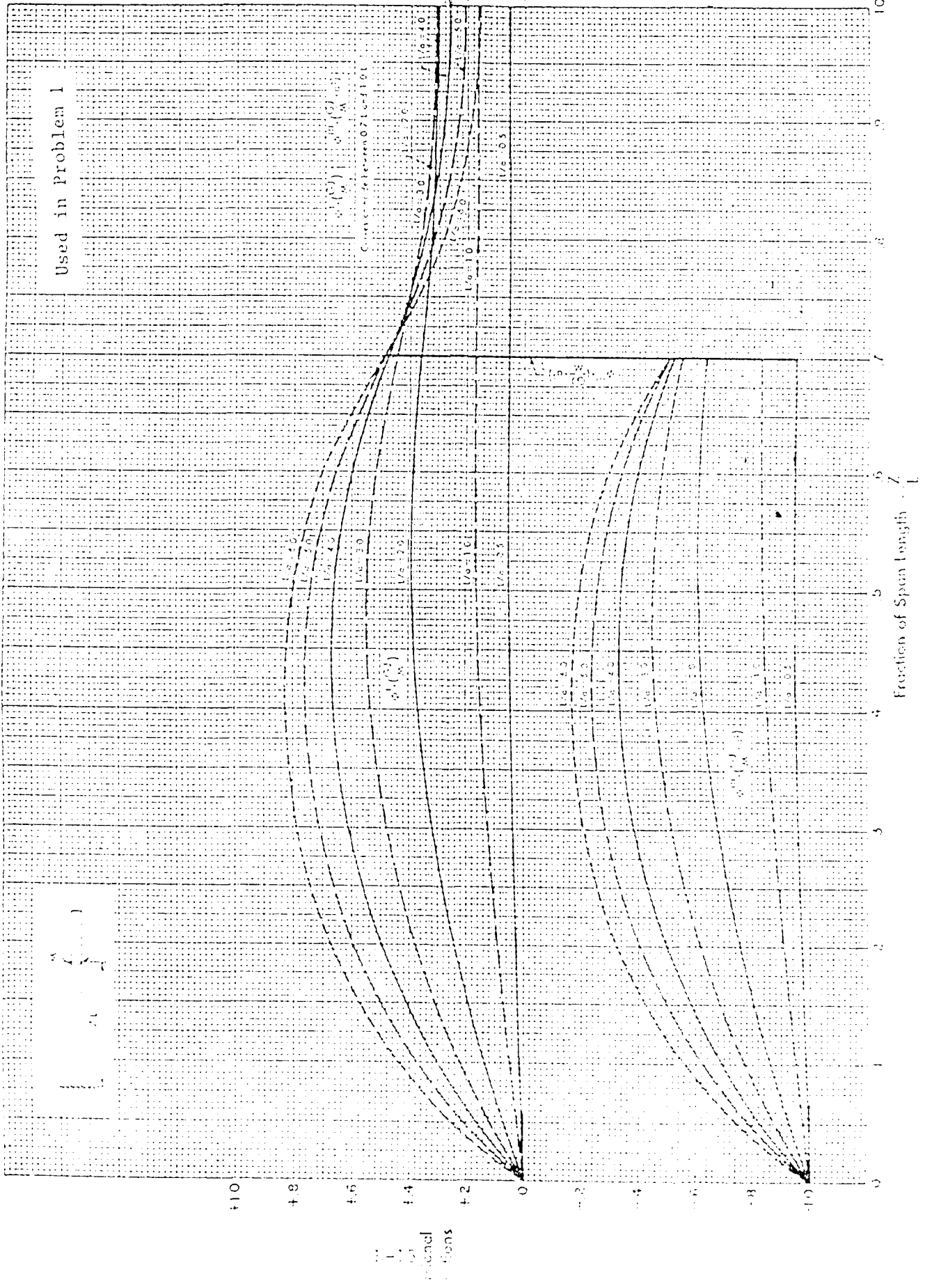

Deflection - W

Case 9

$\alpha = 1.0$ ϕ, ϕ''

CASE 9
 $\alpha = 1.0$ ϕ, ϕ''

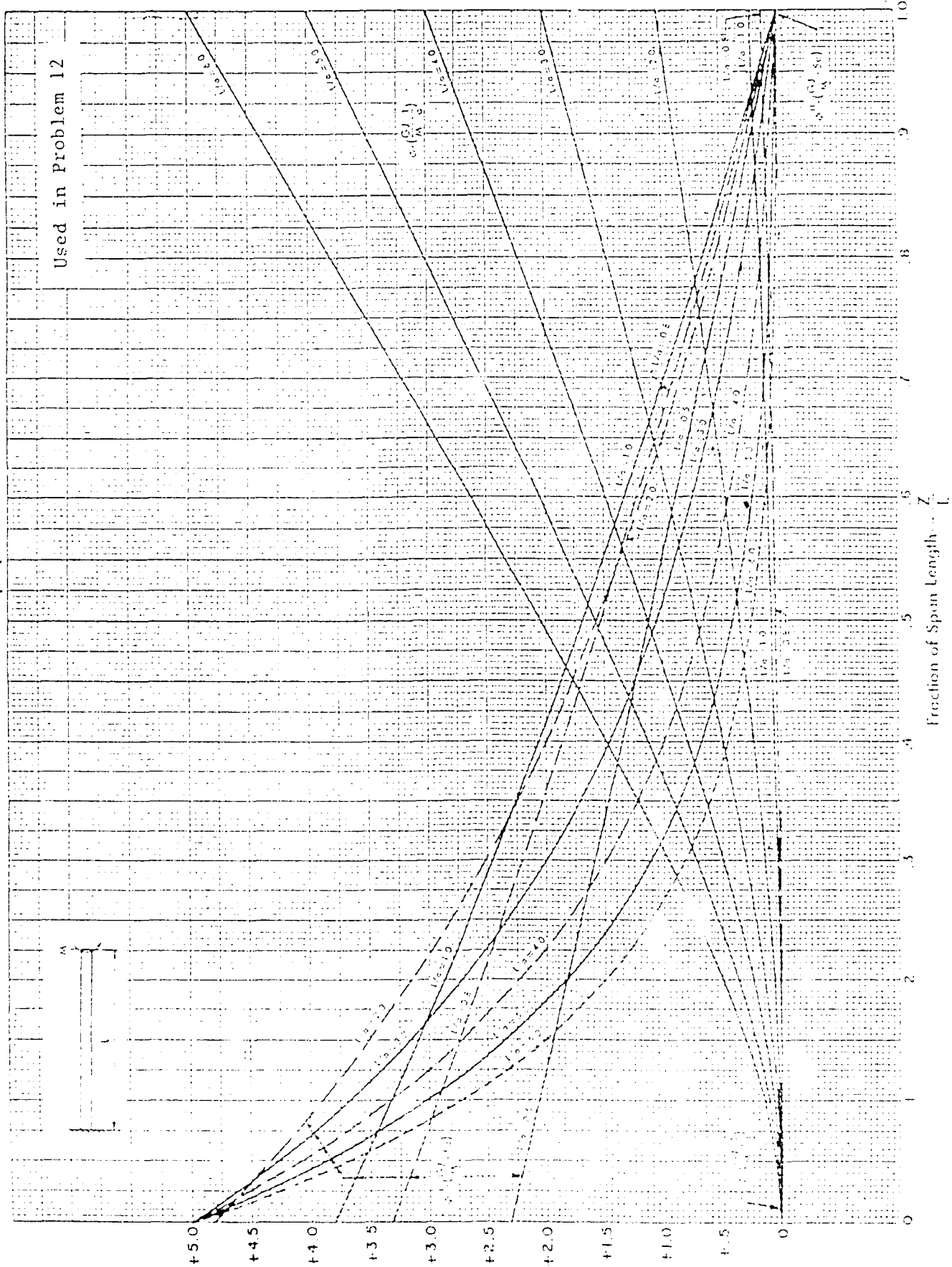

Used in Problem 12

Fraction of Span Length - Z/L

$\alpha = 1.0 \quad \phi', \phi'''$

CASE 9
 $\alpha = 1.0 \quad \phi', \phi'''$

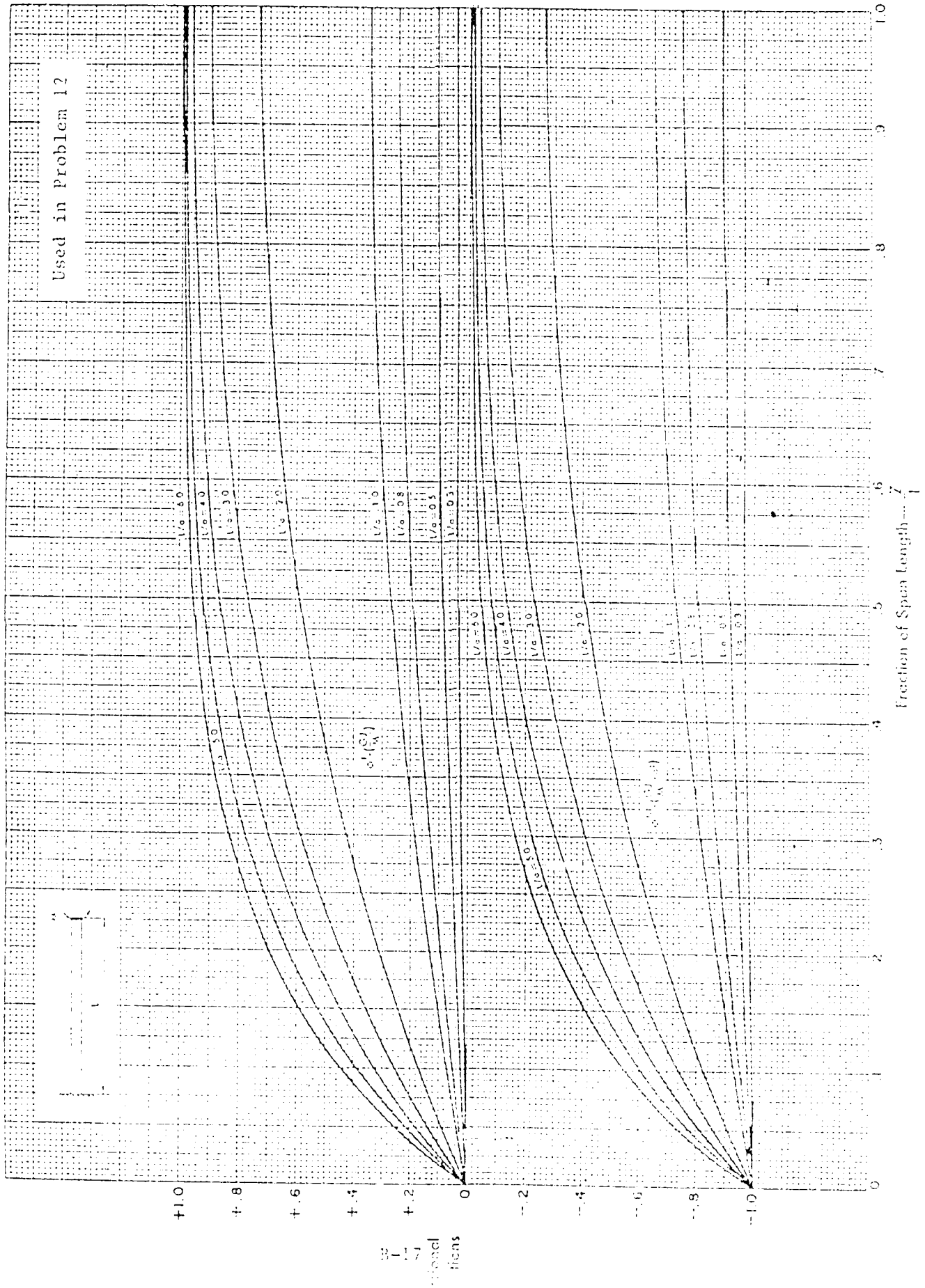

Case 10

$\alpha = 0.3 \quad \phi, \phi''$

CASE 10
 $\alpha = 0.3 \quad \phi, \phi''$

Used in Problems 8 and 10

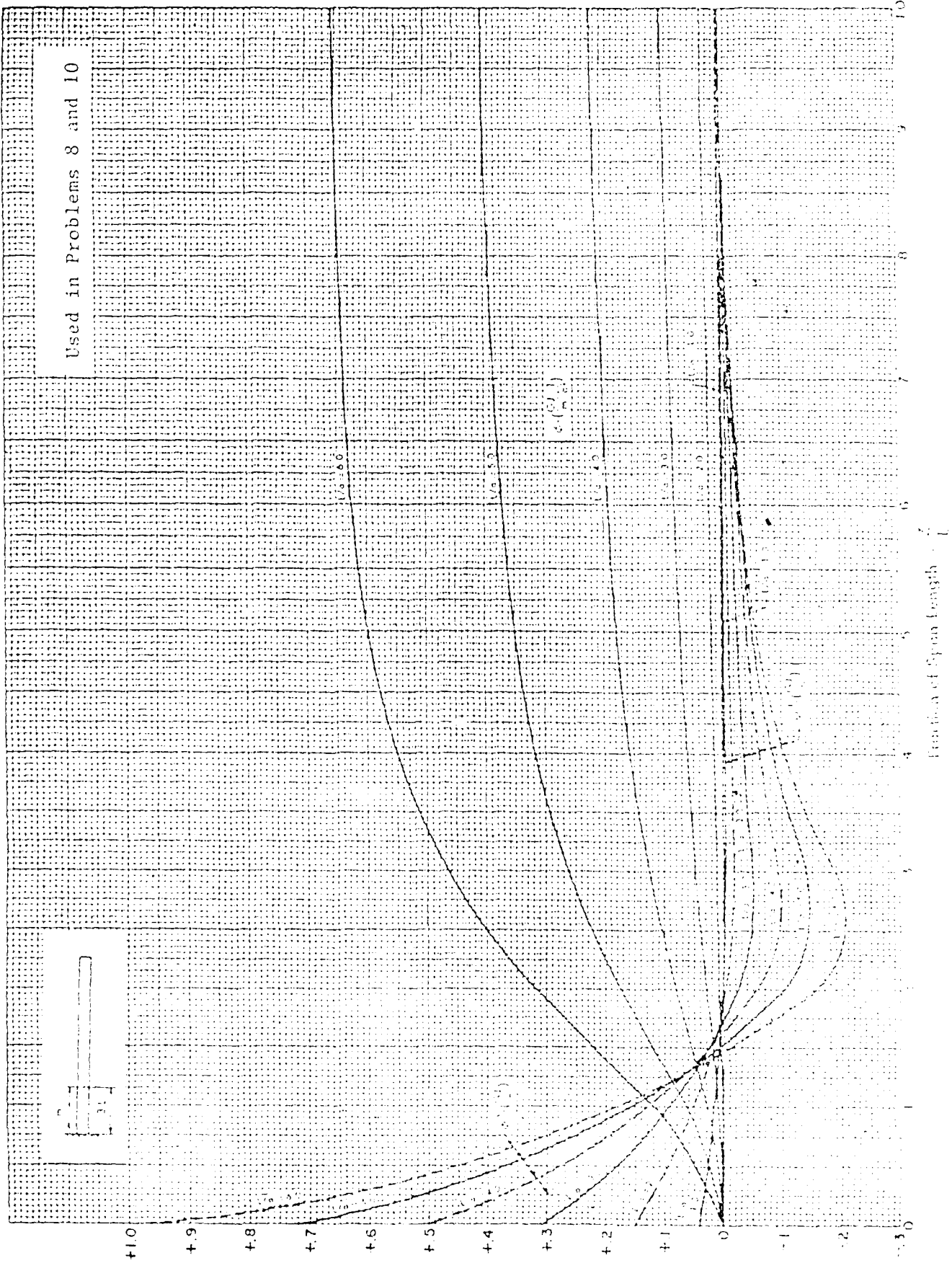

ϕ
 ϕ''

Fraction of Span Length = ξ

CASE 10
 $\alpha = 0.3 \phi', \phi'''$

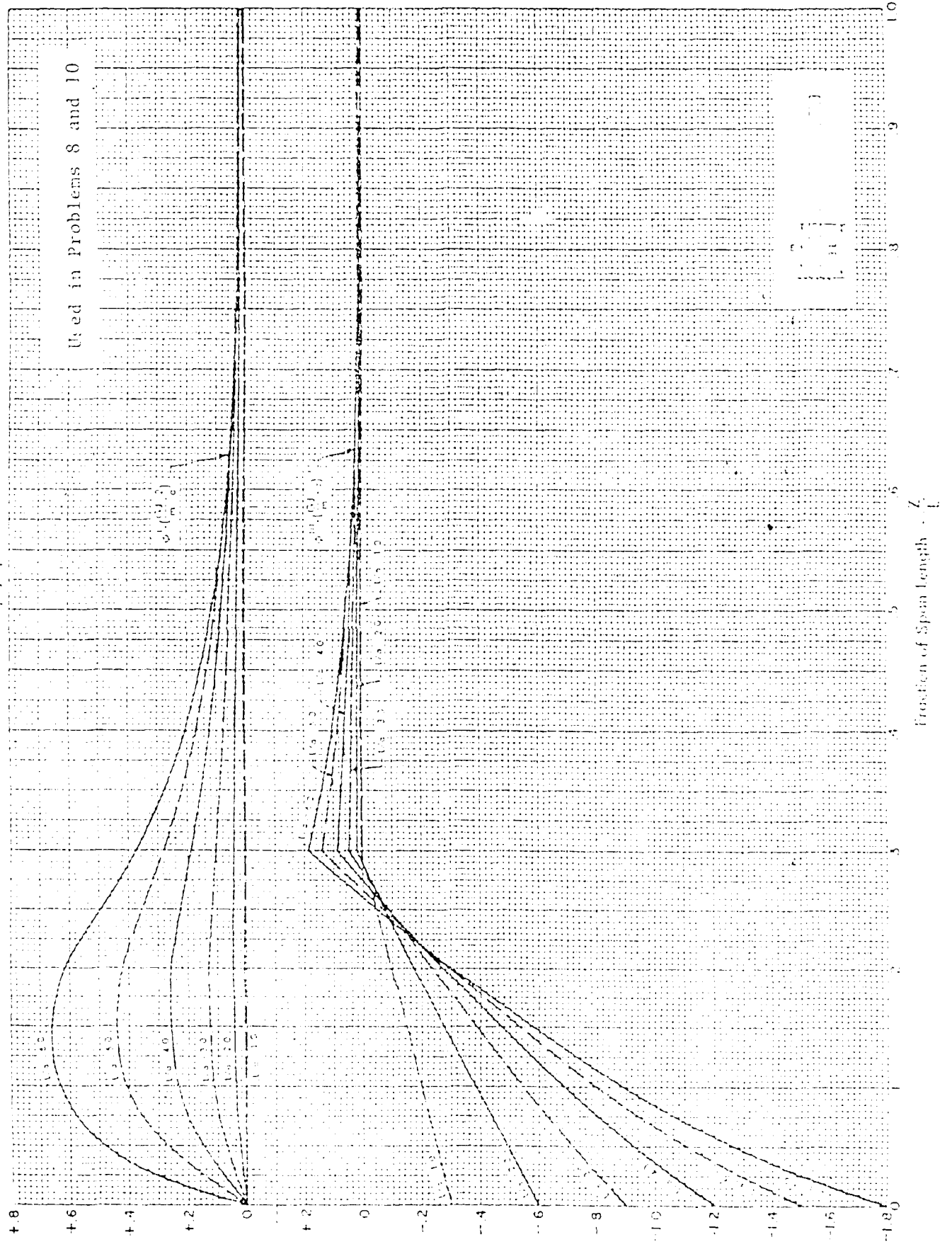
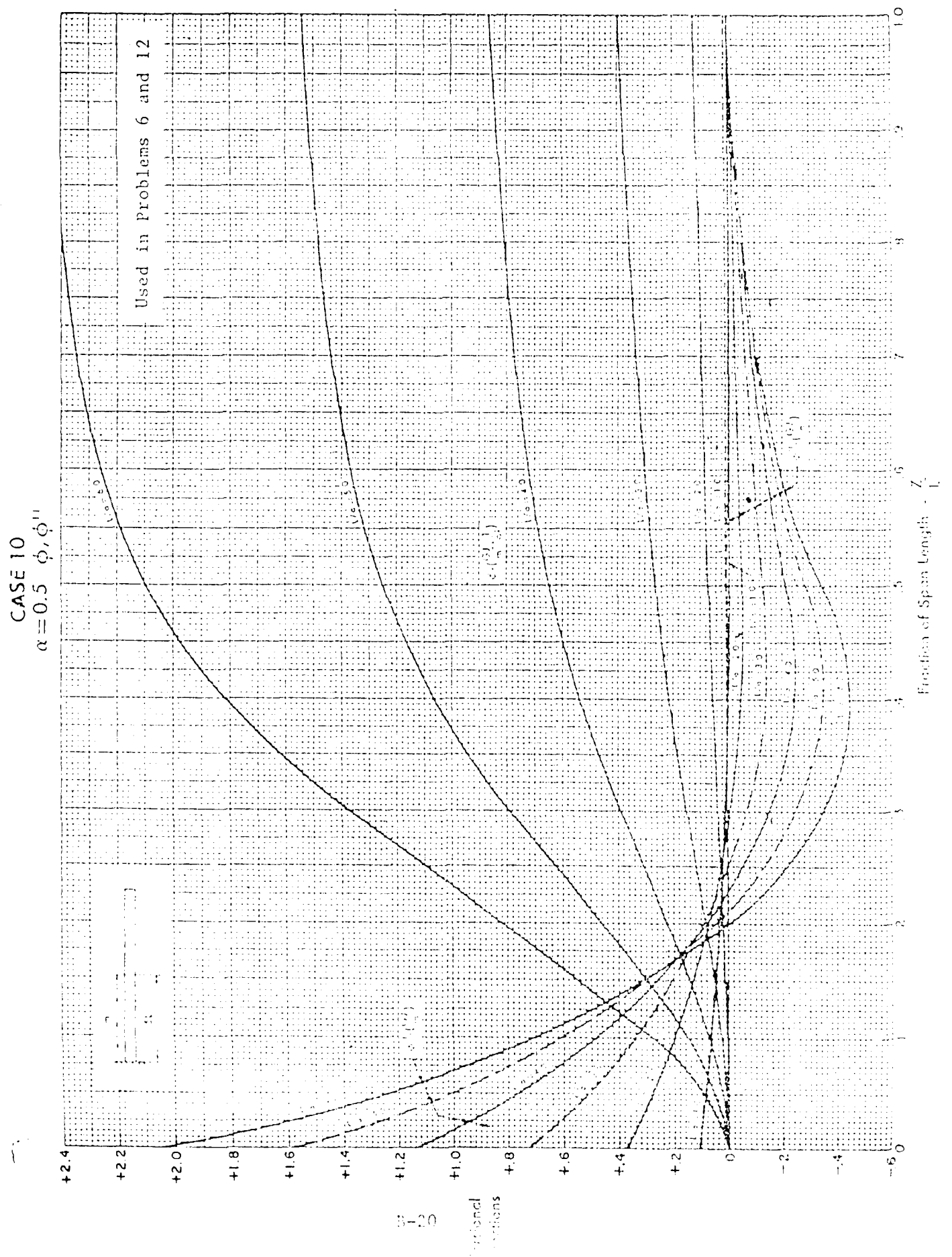

Fig. 10
Boundary
Conditions

Case 10

$\alpha = 0.5 \quad \phi, \phi''$



CASE 10

$\alpha = 0.5 \quad \phi', \phi''$

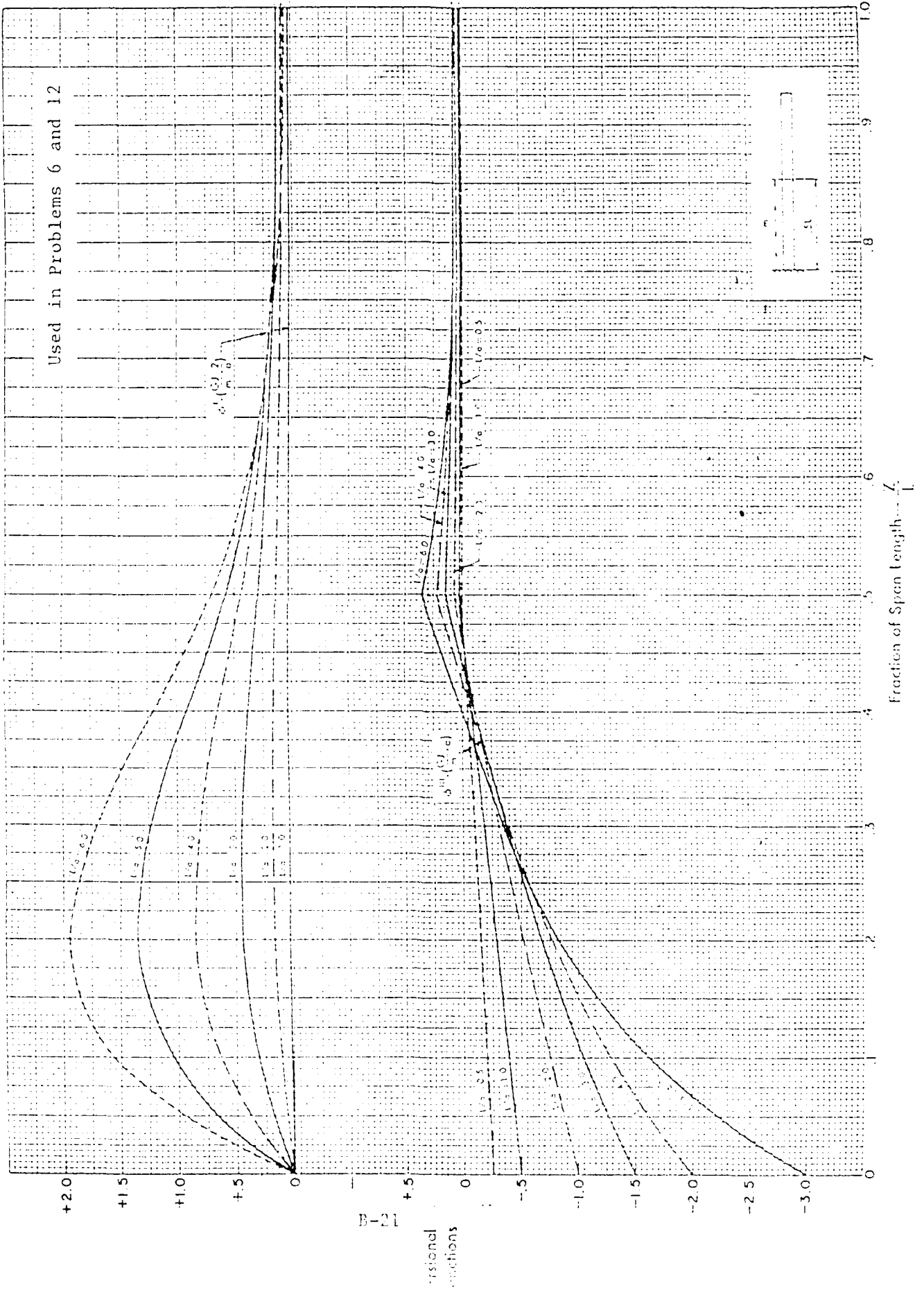

$\alpha = 0.7 \quad \phi, \phi''$

CASE 10
 $\alpha = 0.7 \quad \phi, \phi''$

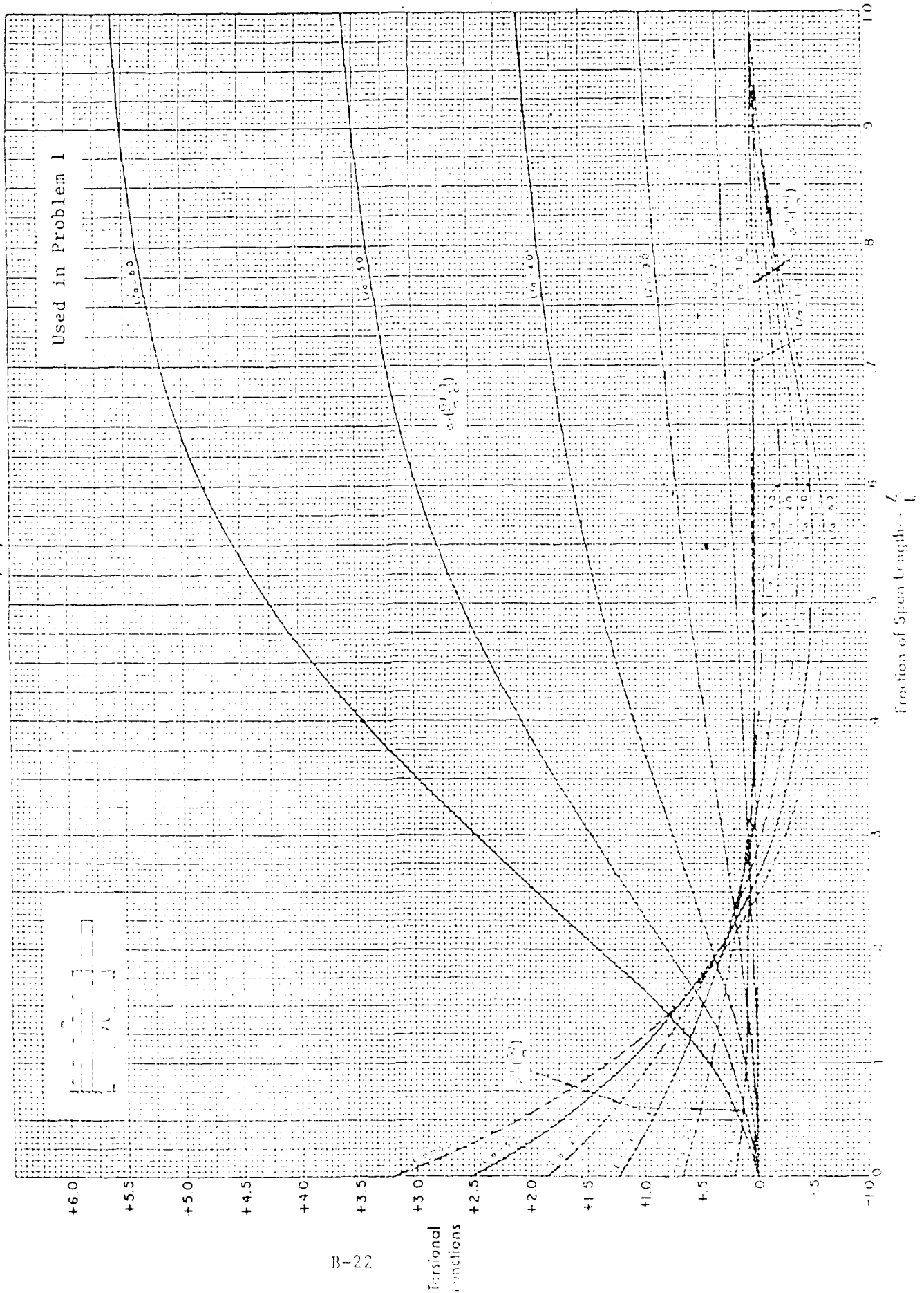

$\alpha = 0.7 \quad \phi', \phi'''$

CASE 10
 $\alpha = 0.7 \quad \phi', \phi'''$

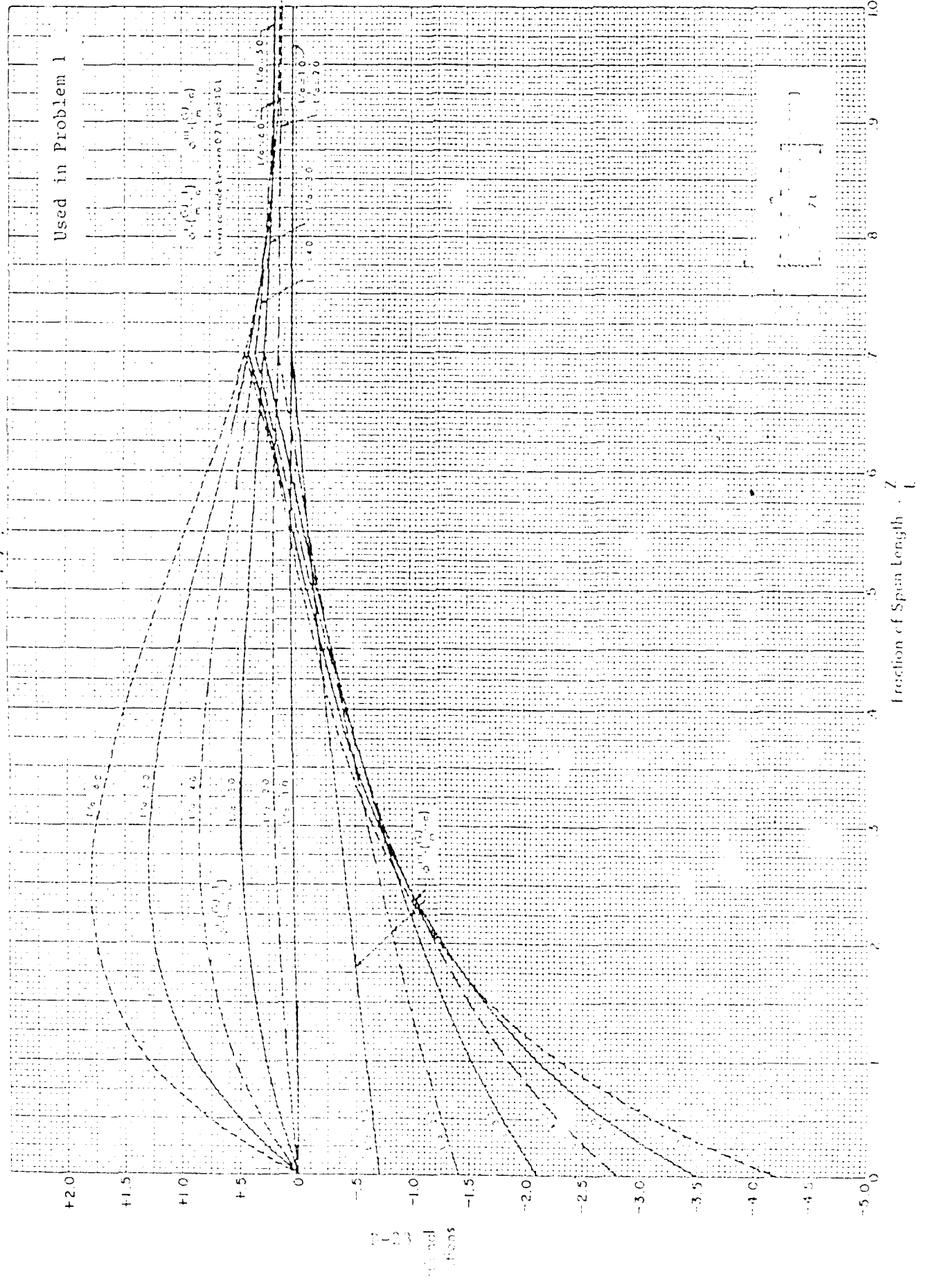

CASE 10
 $\alpha = 1.0 \phi', \phi'''$

Used in Problems 8, 9 and 10

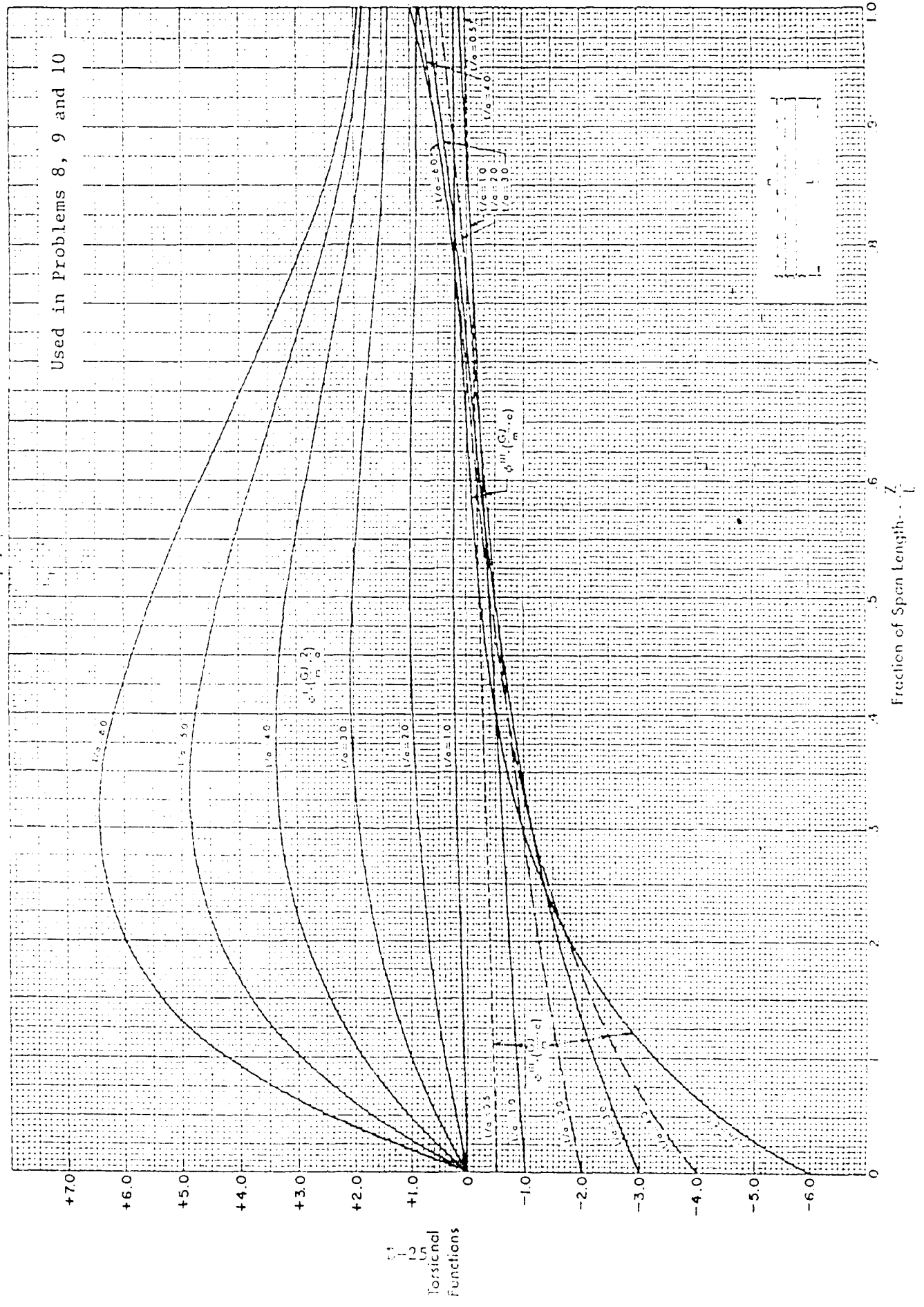

Torsional functions

Fraction of Span Length - Z/L

Case 12

ϕ, ϕ''

CASE 12
 ϕ, ϕ''

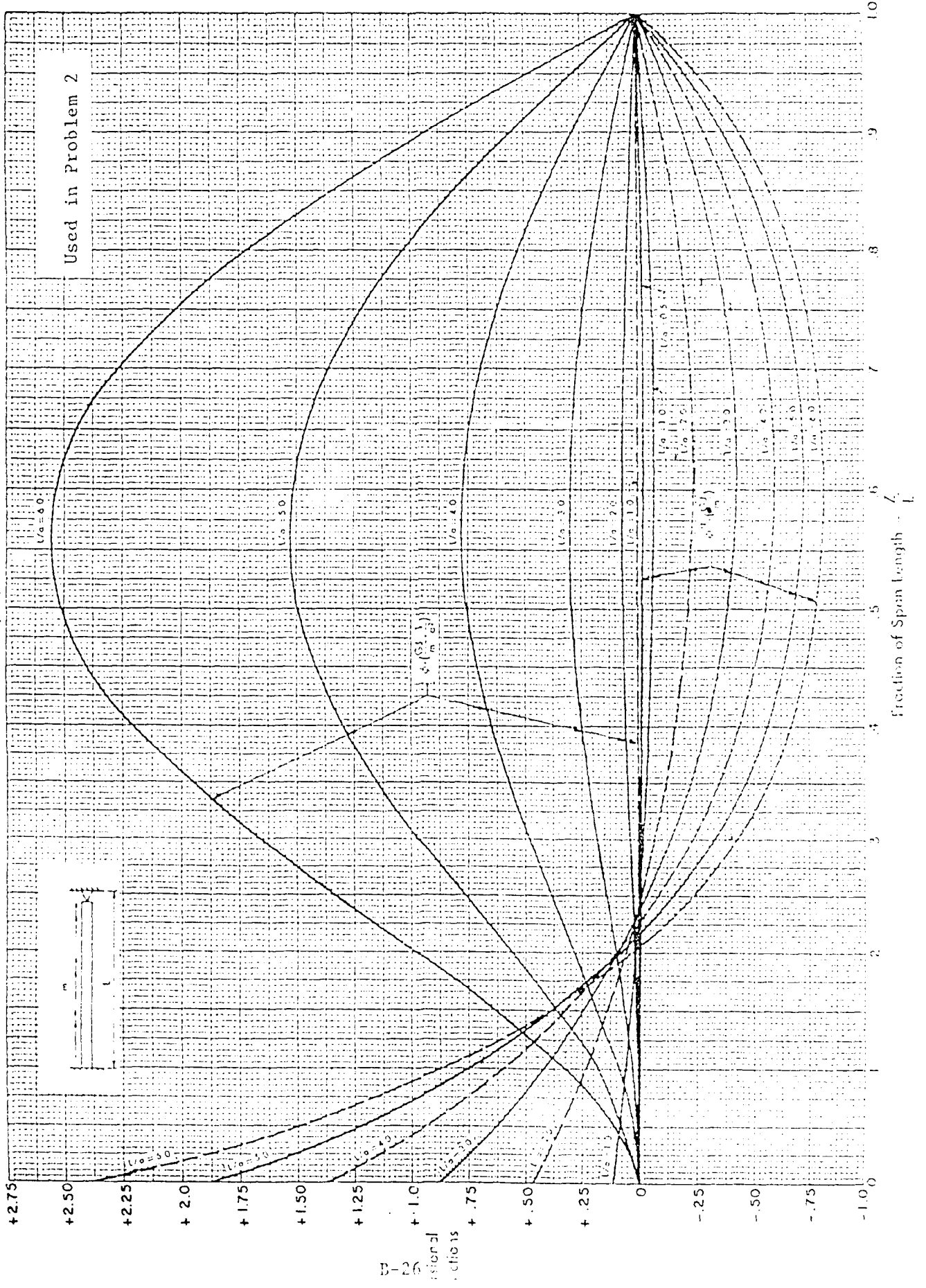

CASE 12
 ϕ', ϕ'''

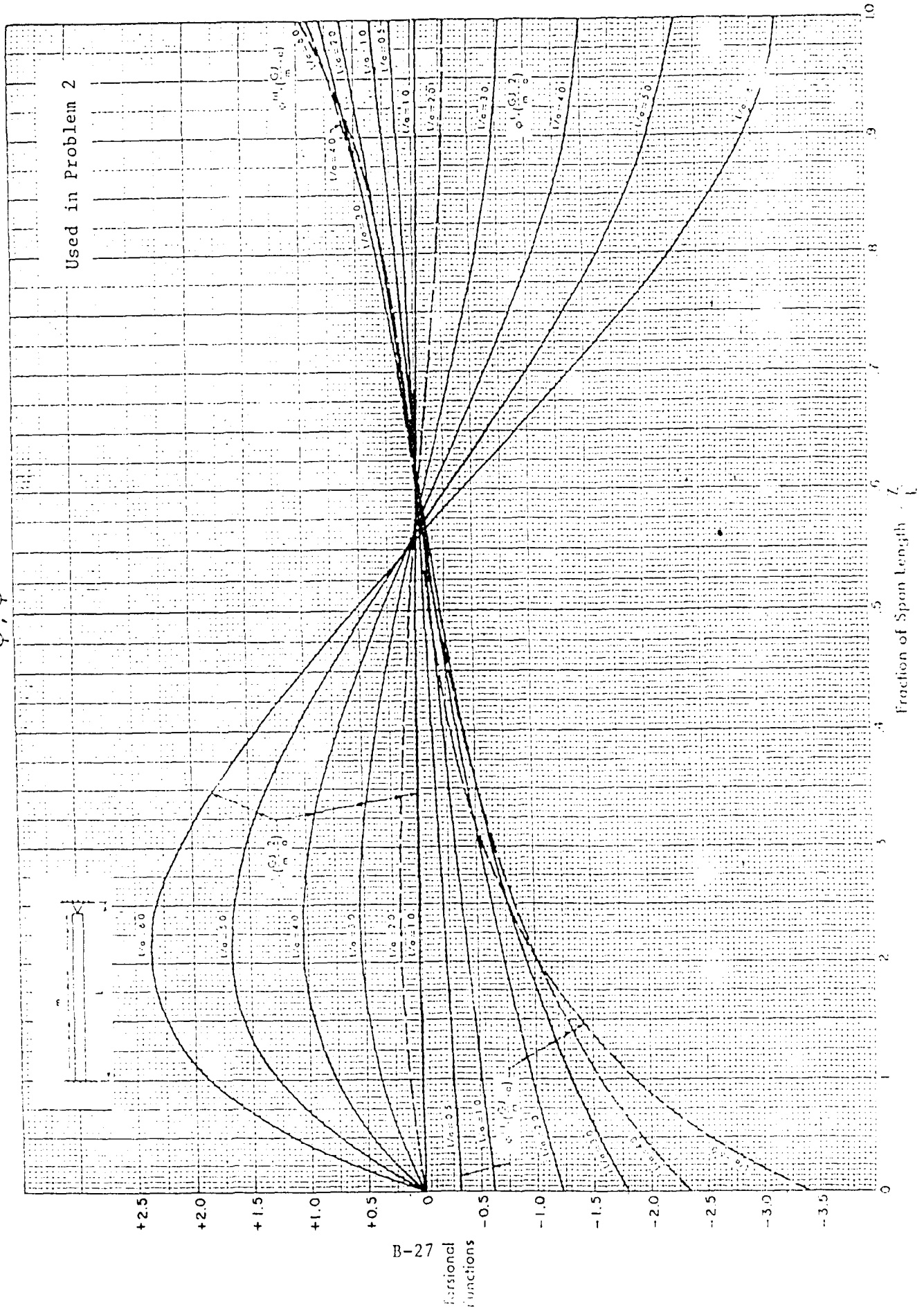

APPENDIX C

"TORSION" PROGRAM INPUT FILES
AND OUTPUT PRINTOUTS

<u>Problem No.</u>	<u>Beam Selected</u>	<u>End Conditions</u>
1	W14x109	Fixed-Free
2	W14x159	Pinned-Fixed
3	W12x79	Pinned-Pinned
4	W14x90	Fixed-Fixed
5	W8x15	Fixed-Free
6	W10x49	Fixed-Free
7	W6x15	Fixed-Free
8	W8x67	Fixed-Free
9	C10x20	Fixed-Free
10	C12x30	Fixed-Free
11	C5x9	Fixed-free
12	MC18x42	Fixed-Free

"TORSION" PROGRAM INPUT FILE

Problem: 1
Beam Selected: W14x109
End Conditions: Fixed-Free

'W-FLANGE' 'W14x109'
32.0 0.525 0.860
14.32 14.605
447.0 61.2
1240.0 173.0
7.12 29000.0 11200.0
300.0
3
0.0 210.0 300.0
10.0 5.0 0.0
-102.5 0.0 -1050.0
'FIX-FRE'
2
210.0 0.0 -5.0 0.0 50.0 0.0 0.0
300.0 -10.0 0.0 0.0 0.0 0.0
0.0 0.0 0.0
0.0 0.0 0.0
0.25 210.0
'Y'

INPUT DATA

PROBLEM 1

WIDE FLANGE SECTION W14X109

AREA:	32.0000	THW:	.5250	THF:	.8600				
IY:	447.0000	SY:	61.2000	IZ:	1240.0000	SZ:	173.0000	Z0:	14.6050
J:	7.1200	CW:	20224.6900	WN1:	49.1458				
SW2:	154.3216	E:	29000.0000	G:	11200.0000				
QY2:	40.7461	QY4:	94.3494	QZ2:	22.9008				

LENGTH: 300.0000

SECTIONS WHERE STRESSES ARE TO BE CHECKED

.0000

210.0000

300.0000

LEFT END FORCES

FX:	10.0000	FY:	5.0000	FZ:	.0000
MX:	-102.5000	MY:	.0000	MZ:	-1050.0000

1 SET OF APPLIED CONCENTRATED LOADS ARE AT 210.00 INCHES FROM LEFT END

FX:	.0000	FY:	-5.0000	FZ:	.0000
MX:	50.0000	MY:	.0000	MZ:	.0000

2 SET OF APPLIED CONCENTRATED LOADS ARE AT 300.00 INCHES FROM LEFT END

FX:	-10.0000	FY:	.0000	FZ:	.0000
MX:	.0000	MY:	.0000	MZ:	.0000

UNIFORM LOAD ON MEMBER IN Y-DIR

WY:	.0000	LAY:	.0000	LBW:	.0000
-----	-------	------	-------	------	-------

UNIFORM LOAD ON MEMBER IN Z-DIR

WZ:	.0000	LAZ:	.0000	LBZ:	.0000
-----	-------	------	-------	------	-------

UNIFORMLY DISTRIBUTED TORSIONAL LOAD IS

WX:	.2500	LX:	210.0000
-----	-------	-----	----------

MEMBER END CONDITIONS ARE FIX-FRE

DISTANCE FROM LEFT END OF MEMBER TO SECTION UNDER EXAMINATION IS .0000

SFY =	-5.0000	SFZ =	.0000
SHY2 =	-.1910	SHY4 =	-.7293
SHZ2 =	.0000		
BMY =	.0000	BMZ =	1050.0000
BSY1 =	.0000	BSZ1 =	-6.0694
AXSTR =	-.3125		

TORSION MOMENT = 50.0000 LOCATION = 210.0000
PHI = .00000E+00 PHI1 = .00000E+00 PHI2 = .67439E-05 PHI3 = -.65249E-07

TOR. SHR. WEB =	.000000	TOR. SHR. FLANGE =	.000000
WARP. SHR. STR. =	.443625	WARP. NDR. STR. =	9.611619

UNIFORMLY DISTRIBUTED TORSIONAL MOMENT = .25000000 ENDING AT 210.00000 FROM LEFT END

PHI = .00000E+00 PHI1 = .00000E+00 PHI2 = .48314E-05 PHI3 = -.89512E-07

TOR. SHR. WEB =	.000000	TOR. SHR. FLANGE =	.000000
WARP. SHR. STR. =	.465807	WARP. NDR. STR. =	6.885823

COMBINED TORSIONAL INDUCED STRESSES

TOR. SHR. WEB =	.000000	TOR. SHR. FLANGE =	.000000
WARP. SHR. STR. =	.309432	WARP. NDR. STR. =	16.497440

NORMAL STRESSES (KSI)

POINT	WITHOUT TORSION	TORSION ONLY	COMBINED STRESS
1	-6.381864	-16.497440	-22.879310
3	-6.381864	16.497440	10.115580
5	5.756864	16.497440	22.254310
7	5.756864	-16.497440	-10.740580

SHEAR STRESSES (KSI)

POINT	WITHOUT TORSION	TORSION ONLY	COMBINED STRESS
2L	-.191045	.909432	.718387
2R	.191045	.909432	1.100477
4L	-.729258	.000000	-.729258
4R	-.729258	.000000	-.729258
6L	.191045	-.909432	-.718387
6R	-.191045	-.909432	-1.100477

POINT LOCATIONS OF COMPUTED STRESSES

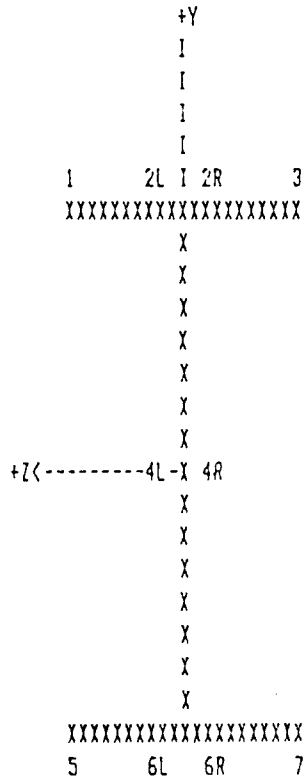

DISTANCE FROM LEFT END OF MEMBER TO SECTION UNDER EXAMINATION IS 210.0000

SFY =	-5.0000	SFZ =	.0000
SHY2 =	-.1910	SHY4 =	-.7293
SHZ2 =	.0000		
BMY =	.0000	BMZ =	2100.0000
BSY1 =	.0000	BSZ1 =	-12.1387
AXSTR =	-.3125		

TORSION MOMENT = 50.0000 LOCATION = 210.0000
PHI = .62399E-01 PHI1 = .29348E-03 PHI2 = -.26746E-05 PHI3 = -.45347E-07

TOR. SHR. WEB =	1.725642	TOR. SHR. FLANGE =	2.826766
WARP. SHR. STR. =	.235982	WARP. NOR. STR. =	-3.811879

UNIFORMLY DISTRIBUTED TORSIONAL MOMENT = .25000000 ENDING AT 210.00000 FROM LEFT END

PHI = .27839E-01 PHI1 = .85845E-04 PHI2 = -.78235E-06 PHI3 = .11672E-07

TOR. SHR. WEB =	.504763	TOR. SHR. FLANGE =	.826859
WARP. SHR. STR. =	-.060738	WARP. NOR. STR. =	-1.115034

COMBINED TORSIONAL INDUCED STRESSES

TOR. SHR. WEB =	2.230411	TOR. SHR. FLANGE =	3.653625
WARP. SHR. STR. =	.175244	WARP. NOR. STR. =	-4.326913

NORMAL STRESSES (KSI)

POINT	WITHOUT TORSION	TORSION ONLY	COMBINED STRESS
1	-12.451230	4.926913	-7.524315
3	-12.451230	-4.926913	-17.378140
5	11.826230	-4.926913	6.899315
7	11.826230	4.926913	16.753140

SHEAR STRESSES (KSI)

POINT	WITHOUT TORSION	TORSION ONLY	COMBINED STRESS
2L	-.191045	3.828870	3.637825
2R	.191045	3.828870	4.019915
4L	-.729258	-2.230411	-2.959669
4R	-.729258	2.230411	1.501152
6L	.191045	-3.828870	-3.637825
6R	-.191045	-3.828870	-4.019915

POINT LOCATIONS OF COMPUTED STRESSES

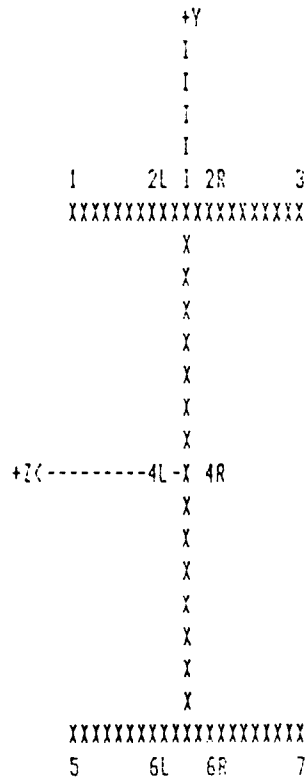

DISTANCE FROM LEFT END OF MEMBER TO SECTION UNDER EXAMINATION IS 300.0000

SFY =	.0000	SFZ =	.0000
SHY2 =	.0000	SHY4 =	.0000
SHZ2 =	.0000		
BMY =	.0000	BMZ =	2100.0000
BSY1 =	.0000	BSZ1 =	-12.1387
AXSTR =	-.3125		

TORSION MOMENT = 50.0000 LOCATION = 210.0000
PHI = .82070E-01 PHI1 = .18307E-03 PHI2 = .31209E-10 PHI3 = .24890E-07

TOR. SHR. WEB =	1.076437	TOR. SHR. FLANGE =	1.763307
WARP. SHR. STR. =	-.129526	WARP. NOR. STR. =	.000044

UNIFORMLY DISTRIBUTED TORSIONAL MOMENT = .25000000 ENDING AT 210.00000 FROM LEFT END

PHI = .33593E-01 PHI1 = .53550E-04 PHI2 = .91291E-11 PHI3 = .72807E-09

TOR. SHR. WEB =	.314871	TOR. SHR. FLANGE =	.515789
WARP. SHR. STR. =	-.037888	WARP. NOR. STR. =	.000013

COMBINED TORSIONAL INDUCED STRESSES

TOR. SHR. WEB =	1.391308	TOR. SHR. FLANGE =	2.279096
WARP. SHR. STR. =	-.167413	WARP. NOR. STR. =	.000057

NDRMAL STRESSES (KSI)

POINT	WITHOUT TORSION	TORSION ONLY	COMBINED STRESS
1	-12.451230	-.000057	-12.451290
3	-12.451230	.000057	-12.451170
5	11.826230	.000057	11.826290
7	11.826230	-.000057	11.826170

SHEAR STRESSES (KSI)

POINT	WITHOUT TORSION	TORSION ONLY	COMBINED STRESS
2L	.000000	2.111682	2.111682
2R	.000000	2.111682	2.111682
4L	.000000	-1.391308	-1.391308
4R	.000000	1.391308	1.391308
6L	.000000	-2.111682	-2.111682
6R	.000000	-2.111682	-2.111682

POINT LOCATIONS OF COMPUTED STRESSES

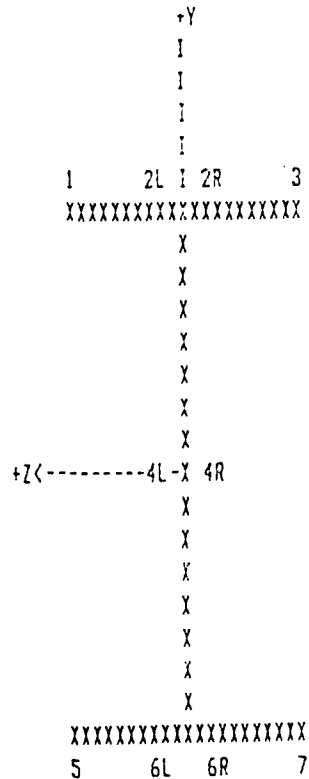

"TORSION" PROGRAM INPUT FILE

Problem: 2
Beam Selected: W14x159
End Conditions: Pinned-Fixed

'W-FLANGE' 'W14x159'
46.7 0.745 1.19
14.98 15.565
748.0 96.2
1900.0 254.0
19.8 29000.0 11200.0
432.0
3
0.0 108.0 432.0
0.0 7.59 0.0
-54.0 0.0 0.0
'PIN-FIX'
1
108.0 0.0 -12.0 0.0 0.0 0.0 0.0
0.0 0.0 0.0
0.0 0.0 0.0
0.25
'Y'

INPUT DATA

PROBLEM 2

WIDE FLANGE SECTION W14X159

AREA:	46.7000	THW:	.7450	THF:	1.1900				
IY:	748.0000	SY:	96.2000	IZ:	1900.0000	SZ:	254.0000	ZD:	15.5650
J:	19.8000	CW:	35555.8900	WN1:	53.6603				
SW2:	248.4789	E:	29000.0000	G:	11200.0000				
QY2:	60.7994	QY4:	142.4361	QZ2:	35.9550				

LENGTH: 432.0000

SECTIONS WHERE STRESSES ARE TO BE CHECKED

.0000
108.0000
432.0000

LEFT END FORCES

FX:	.0000	FY:	7.5900	FZ:	.0000
MX:	-54.0000	MY:	.0000	MZ:	.0000

1 SET OF APPLIED CONCENTRATED LOADS ARE AT 108.00 INCHES FROM LEFT END

FX:	.0000	FY:	-12.0000	FZ:	.0000
MX:	.0000	MY:	.0000	MZ:	.0000

UNIFORM LOAD ON MEMBER IN Y-DIR.

MY:	.0000	LAY:	.0000	LBY:	.0000
-----	-------	------	-------	------	-------

UNIFORM LOAD ON MEMBER IN Z-DIR

WZ:	.0000	LAZ:	.0000	LBZ:	.0000
-----	-------	------	-------	------	-------

UNIFORMLY DISTRIBUTED TORSIONAL LOAD IS

WX: .2500

MEMBER END CONDITIONS ARE PIN-FIX

DISTANCE FROM LEFT END OF MEMBER TO SECTION UNDER EXAMINATION IS .0000

SFY =	-7.5900	SFZ =	.0000
SHY2 =	-.2041	SHY4 =	-.7541
SHZ2 =	.0000		
BMZ =	.0000	BMZ =	.0000
BSY1 =	.0000	BSZ1 =	.0000
AXSTR =	.0000		

UNIFORMLY DISTRIBUTED TORSIONAL MOMENT = .2500
PHI= .00000E+00 PHI1= .13633E-03 PHI2= .42778E-13 PHI3= -.16323E-07

TOR. SHR. WEB =	1.137506	TOR. SHR. FLANGE =	1.816956
WARP. SHR. STR. =	.098842	WARP. NOR. STR. =	.000000

COMBINED TORSIONAL INDUCED STRESSES

TOR. SHR. WEB =	1.137506	TOR. SHR. FLANGE =	1.816956
WARP. SHR. STR. =	.098842	WARP. NOR. STR. =	.000000

NORMAL STRESSES (KSI)

POINT	WITHOUT TORSION	TORSION ONLY	COMBINED STRESS
1	.000000	.000000	.000000
3	.000000	.000000	.000000
5	.000000	.000000	.000000
7	.000000	.000000	.000000

SHEAR STRESSES (KSI)

POINT	WITHOUT TORSION	TORSION ONLY	COMBINED STRESS
2L	-.204099	1.915799	1.711700
2R	.204099	1.915799	2.119897
4L	-.764073	-1.137506	-1.901579
4R	-.764073	1.137506	.373433
6L	.204099	-1.915799	-1.711700
6R	-.204099	-1.915799	-2.119897

POINT LOCATIONS OF COMPUTED STRESSES

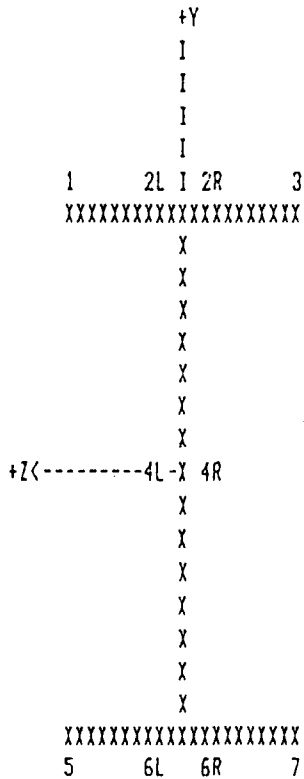

DISTANCE FROM LEFT END OF MEMBER TO SECTION UNDER EXAMINATION IS 108.0000

SFY =	-7.5900	SFZ =	.0000
SHY2 =	-.2041	SHY4 =	-.7641
SHZ2 =	.0000		
BMZ =	.0000	BMZ =	819.7200
BSY1 =	.0000	BSZ1 =	-3.2272
AXSTR =	.0000		

UNIFORMLY DISTRIBUTED TORSIONAL MOMENT = .2500

PHI = .12334E-01 PHI1 = .77173E-04 PHI2 = -.86267E-06 PHI3 = -.28600E-08

TOR. SHR. WEB =	.643927	TOR. SHR. FLANGE =	1.028555
WARP. SHR. STR. =	.017318	WARP. NOR. STR. =	-1.342438

COMBINED TORSIONAL INDUCED STRESSES

TOR. SHR. WEB =	.643927	TOR. SHR. FLANGE =	1.028555
WARP. SHR. STR. =	.017318	WARP. NOR. STR. =	-1.342438

NORMAL STRESSES (KSI)

POINT	WITHOUT TORSION	TORSION ONLY	COMBINED STRESS
1	-3.227244	1.342438	-1.884806
3	-3.227244	-1.342438	-4.569682
5	3.227244	-1.342438	1.884806
7	3.227244	1.342438	4.569682

SHEAR STRESSES (KSI)

POINT	WITHOUT TORSION	TORSION ONLY	COMBINED STRESS
2L	-.204099	1.045874	.841775
2R	.204099	1.045874	1.249372
4L	-.764073	-.643927	-1.408001
4R	-.764073	.643927	-.120146
6L	.204099	-1.045874	-.841775
6R	-.204099	-1.045874	-1.249372

POINT LOCATIONS OF COMPUTED STRESSES

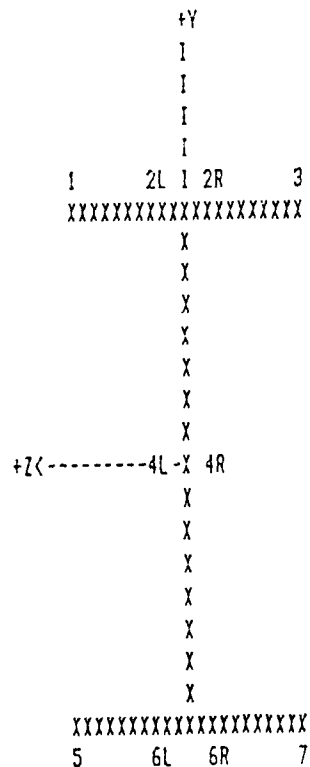

DISTANCE FROM LEFT END OF MEMBER TO SECTION UNDER EXAMINATION IS 432.0000

SFY =	4.4100	SFZ =	.0000
SHY2 =	.1186	SHY4 =	.4439
SHZ2 =	.0000		
BMY =	.0000	BMZ =	-609.1199
BSY1 =	.0000	BSZ1 =	2.3981
AXSTR =	.0000		

UNIFORMLY DISTRIBUTED TORSIONAL MOMENT = .2500
PHI= .72407E-07 PHI1= .10643E-11 PHI2= .29064E-05 PHI3= .59098E-07

TOR. SHR. WEB =	.000000	TOR. SHR. FLANGE =	.000000
WARP. SHR. STR. =	-.357860	WARP. NOR. STR. =	4.522865

COMBINED TORSIONAL INDUCED STRESSES

TOR. SHR. WEB =	.000000	TOR. SHR. FLANGE =	.000000
WARP. SHR. STR. =	-.357860	WARP. NOR. STR. =	4.522865

NORMAL STRESSES (KSI)

POINT	WITHOUT TORSION	TORSION ONLY	COMBINED STRESS
1	2.398110	-4.522865	-2.124755
3	2.398110	4.522865	6.920375
5	-2.398110	4.522865	2.124755
7	-2.398110	-4.522865	-6.920375

SHEAR STRESSES (KSI)

POINT	WITHOUT TORSION	TORSION ONLY	COMBINED STRESS
2L	.118587	-.357860	-.239273
2R	-.118587	-.357860	-.476447
4L	.443948	.000000	.443948
4R	.443948	.000000	.443948
6L	-.118587	.357860	.239273
6R	.118587	.357860	.476447

POINT LOCATIONS OF COMPUTED STRESSES

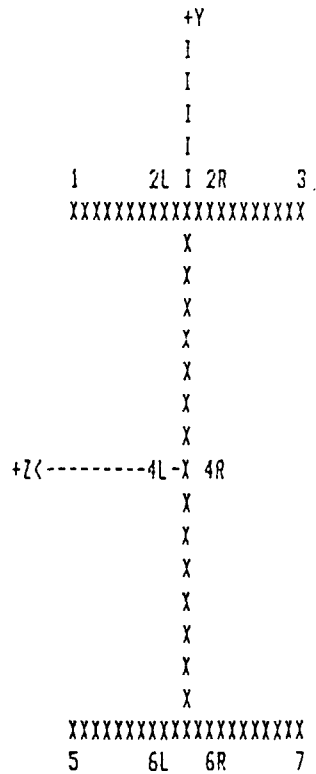

"TORSION" PROGRAM INPUT FILE

Problem: 3
Beam Selected: W12x79
End Conditions: Pinned-Pinned

'W-FLANGE' 'W12x79'
23.2 0.470 0.735
12.38 12.08
216.0 35.8
662.0 107.0
3.84 29000.0 11200.0
360.0
4
0.0 36.0 252.0 360.0
0.0 0.0 0.0
-61.5 0.0 0.0
'PIN-PIN'
2
36.0 0.0 0.0 0.0 60.0 0.0 0.0
252.0 0.0 0.0 0.0 25.0 0.0 0.0
0.0 0.0 0.0
0.0 0.0 0.0
0.0
'Y'

INPUT DATA

PROBLEM 3

WIDE FLANGE SECTION W12X79

AREA:	23.2000	THW:	.4700	THF:	.7350		
IY:	216.0000	SY:	35.8000	IZ:	662.0000	SZ:	107.0000
J:	3.8400	CW:	7320.7550	WN1:	35.1679	Z0:	12.0800
SW2:	78.0622	E:	29000.0000	G:	11200.0000		
QY2:	24.8427	QY4:	58.6897	QI2:	13.3867		

LENGTH: 360.0000

SECTIONS WHERE STRESSES ARE TO BE CHECKED

.0000
 36.0000
 252.0000
 360.0000

LEFT END FORCES

FX:	.0000	FY:	.0000	FZ:	.0000
MX:	-61.5000	MY:	.0000	MZ:	.0000

1 SET OF APPLIED CONCENTRATED LOADS ARE AT 36.00 INCHES FROM LEFT END

FX:	.0000	FY:	.0000	FZ:	.0000
MX:	60.0000	MY:	.0000	MZ:	.0000

2 SET OF APPLIED CONCENTRATED LOADS ARE AT 252.00 INCHES FROM LEFT END

FX:	.0000	FY:	.0000	FZ:	.0000
MX:	25.0000	MY:	.0000	MZ:	.0000

UNIFORM LOAD ON MEMBER IN Y-DIR

WY:	.0000	LAY:	.0000	LBW:	.0000
-----	-------	------	-------	------	-------

UNIFORM LOAD ON MEMBER IN Z-DIR

WZ:	.0000	LAZ:	.0000	LBZ:	.0000
-----	-------	------	-------	------	-------

UNIFORMLY DITRIBUTED TORSIONAL LOAD IS

WX: .0000

MEMBER END CONDITIONS ARE PIN-PIN

DISTANCE FROM LEFT END OF MEMBER TO SECTION UNDER EXAMINATION IS .0000

SFY =	.0000	SFZ =	.0000
SHY2 =	.0000	SHY4 =	.0000
SHZ2 =	.0000		
BY1 =	.0000	BY2 =	.0000
BSY1 =	.0000	BSZ1 =	.0000
AXSTR =	.0000		

TORSION MOMENT = 60.0000 LOCATION = 35.0000
PHI = .00000E+00 PHI1 = .41989E-03 PHI2 = .00000E+00 PHI3 = -.16929E 06

TOR. SHR. WEB =	2.210289	TOR. SHR. FLANGE =	3.456516
WARP. SHR. STR. =	.521427	WARP. NOR. STR. =	.000000

TORSION MOMENT = 25.0000 LOCATION = 252.0000
PHI = .00000E+00 PHI1 = .15903E-03 PHI2 = .00000E+00 PHI3 = -.31100E-08

TOR. SHR. WEB =	.837155	TOR. SHR. FLANGE =	1.309166
WARP. SHR. STR. =	.009579	WARP. NOR. STR. =	.000000

COMBINED TORSIONAL INDUCED STRESSES

TOR. SHR. WEB =	3.047444	TOR. SHR. FLANGE =	4.765684
WARP. SHR. STR. =	.531006	WARP. NOR. STR. =	.000000

NORMAL STRESSES (KSI)

POINT	WITHOUT TORSION	TORSION ONLY	COMBINED STRESS
1	.000000	.000000	.000000
3	.000000	.000000	.000000
5	.000000	.000000	.000000
7	.000000	.000000	.000000

SHEAR STRESSES (KSI)

POINT	WITHOUT TORSION	TORSION ONLY	COMBINED STRESS
2L	.000000	5.296690	5.296690
2R	.000000	5.296690	5.296690
4L	.000000	-3.047444	-3.047444
4R	.000000	3.047444	3.047444
6L	.000000	-5.296690	-5.296690
6R	.000000	-5.296690	-5.296690

POINT LOCATIONS OF COMPUTED STRESSES

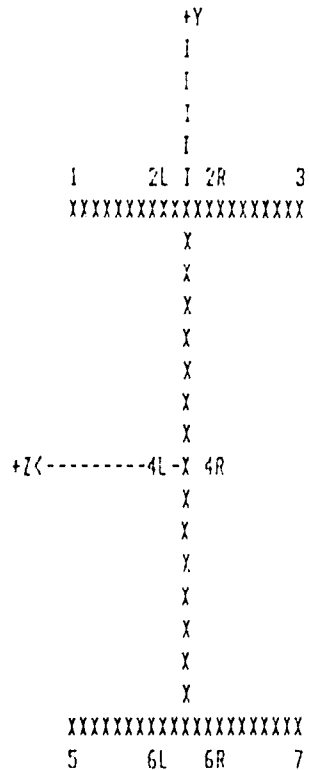

DISTANCE FROM LEFT END OF MEMBER TO SECTION UNDER EXAMINATION IS 36.0000

SFY =	.0000	SFZ =	.0000
SHY2 =	.0000	SHY4 =	.0000
SHZ2 =	.0000		
BYM =	.0000	BMZ =	.0000
BSY1 =	.0000	BSZ1 =	.0000
AXSTR =	.0000		

TORSION MOMENT = 60.0000 LOCATION = 36.0000
PHI = .13782E-01 PHI1 = .30776E-03 PHI2 = -.63648E-05 PHI3 = -.19201E-06

TOR. SHR. WEB =	1.620069	TOR. SHR. FLANGE =	2.533512
WARP. SHR. STR. =	.591386	WARP. NOR. STR. =	-6.491257

TORSION MOMENT = 25.0000 LOCATION = 252.0000
PHI = .57007E-02 PHI1 = .15697E-03 PHI2 = -.11692E-06 PHI3 = -.35273E-09

TOR. SHR. WEB =	.826313	TOR. SHR. FLANGE =	1.292212
WARP. SHR. STR. =	.010864	WARP. NOR. STR. =	-.119248

COMBINED TORSIONAL INDUCED STRESSES

TOR. SHR. WEB =	2.446382	TOR. SHR. FLANGE =	3.825725
WARP. SHR. STR. =	.602250	WARP. NOR. STR. =	-6.610505

NORMAL STRESSES (KSI)

POINT	WITHOUT TORSION	TORSION ONLY	COMBINED STRESS
1	.000000	6.610505	6.610505
3	.000000	-6.610505	-6.610505
5	.000000	-6.610505	-6.610505
7	.000000	6.610505	6.610505

SHEAR STRESSES (KSI)

POINT	WITHOUT TORSION	TORSION ONLY	COMBINED STRESS
2L	.000000	4.427975	4.427975
2R	.000000	4.427975	4.427975
4L	.000000	-2.446382	-2.446382
4R	.000000	2.446382	2.446382
6L	.000000	-4.427975	-4.427975
6R	.000000	-4.427975	-4.427975

POINT LOCATIONS OF COMPUTED STRESSES

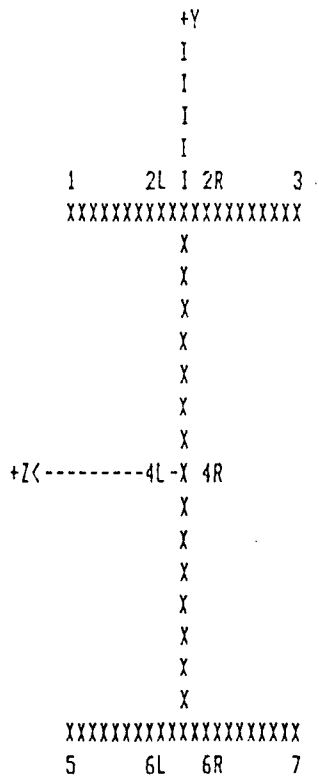

DISTANCE FROM LEFT END OF MEMBER TO SECTION UNDER EXAMINATION IS 252.0000

SFY =	.0000	SFZ =	.0000
SHY2 =	.0000	SHY4 =	.0000
SHZ2 =	.0000		
BMZ =	.0000	BMZ =	.0000
BSY1 =	.0000	BSZ1 =	.0000
AXSTR =	.0000		

TORSION MOMENT = 60.0000 LOCATION = 36.0000
PHI = .13682E-01 PHI1 = -.11788E-03 PHI2 = -.28060E-06 PHI3 = .43808E-08

TOR. SHR. WEB =	-.620541	TOR. SHR. FLANGE =	-.970421
WARP. SHR. STR. =	-.013493	WARP. NOR. STR. =	-.286171

TORSION MOMENT = 25.0000 LOCATION = 252.0000
PHI = .24483E-01 PHI1 = -.10305E-03 PHI2 = -.39427E-05 PHI3 = -.56203E-07

TOR. SHR. WEB =	-.542465	TOR. SHR. FLANGE =	-.848323
WARP. SHR. STR. =	.173106	WARP. NOR. STR. =	-4.021075

COMBINED TORSIONAL INDUCED STRESSES

TOR. SHR. WEB =	-1.163006	TOR. SHR. FLANGE =	-1.818743
WARP. SHR. STR. =	.159613	WARP. NOR. STR. =	-4.307246

NORMAL STRESSES (KSI)

POINT	WITHOUT TORSION	TORSION ONLY	COMBINED STRESS
1	.000000	4.307246	4.307246
3	.000000	-4.307246	-4.307246
5	.000000	-4.307246	-4.307246
7	.000000	4.307246	4.307246

SHEAR STRESSES (KSI)

POINT	WITHOUT TORSION	TORSION ONLY	COMBINED STRESS
2L	.000000	-1.659130	-1.659130
2R	.000000	-1.659130	-1.659130
4L	.000000	1.163006	1.163006
4R	.000000	-1.163006	-1.163006
6L	.000000	1.659130	1.659130
6R	.000000	1.659130	1.659130

POINT LOCATIONS OF COMPUTED STRESSES

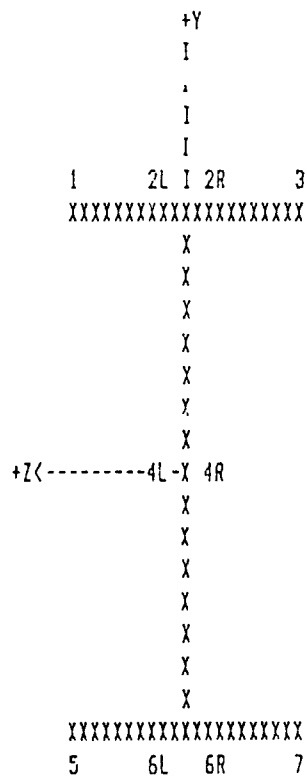

DISTANCE FROM LEFT END OF MEMBER TO SECTION UNDER EXAMINATION IS 360.0000

SFY =	.0000	SFZ =	.0000
SHY2 =	.0000	SHY4 =	.0000
SHZ2 =	.0000		
BHY =	.0000	BMZ =	.0000
BSY1 =	.0000	BSZ1 =	.0000
AXSTR =	.0000		

TORSION MOMENT = 60.0000 LOCATION = 36.0000
PHI = .50615E-07 PHI1 = -.13062E-03 PHI2 = .12315E-10 PHI3 = .18002E-08

TOR. SHR. WEB =	-.687598	TOR. SHR. FLANGE =	-1.075287
WARP. SHR. STR. =	-.005544	WARP. NOR. STR. =	.000013

TORSION MOMENT = 25.0000 LOCATION = 252.0000
PHI = .35712E-07 PHI1 = -.28206E-03 PHI2 = .71444E-11 PHI3 = .25290E-07

TOR. SHR. WEB =	-1.484768	TOR. SHR. FLANGE =	-2.321924
WARP. SHR. STR. =	-.077894	WARP. NOR. STR. =	.000007

COMBINED TORSIONAL INDUCED STRESSES

TOR. SHR. WEB =	-2.172366	TOR. SHR. FLANGE =	-3.397211
WARP. SHR. STR. =	-.083438	WARP. NOR. STR. =	.000020

NORMAL STRESSES (KSI)

POINT	WITHOUT TORSION	TORSION ONLY	COMBINED STRESS
1	.000000	-.000020	-.000020
3	.000000	.000020	.000020
5	.000000	.000020	.000020
7	.000000	-.000020	-.000020

SHEAR STRESSES (KSI)

POINT	WITHOUT TORSION	TORSION ONLY	COMBINED STRESS
2L	.000000	-3.480649	-3.480649
2R	.000000	-3.480649	-3.480649
4L	.000000	2.172366	2.172366
4R	.000000	-2.172366	-2.172366
6L	.000000	3.480649	3.480649
6R	.000000	3.480649	3.480649

POINT LOCATIONS OF COMPUTED STRESSES

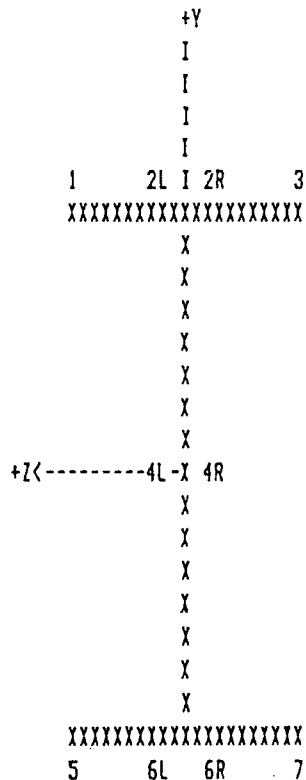

"TORSION" PROGRAM INPUT FILE

Problem: 4
Beam Selected: W14x90
End Conditions: Fixed-Fixed

'W-FLANGE' 'W14x90'
26.5 0.440 0.710
14.02 14.52
362.0 49.9
999.0 143.0
4.06 29000.0 11200.0
480.0
3
0.0 240.0 480.0
0.0 12.0 0.0
-97.0 0.0 -960.0
'FIX-FIX'
1
240.0 0.0 0.0 0.0 50.0 0.0 0.0
-0.05 0.0 480.0
0.0 0.0 0.0
0.3
'Y'

INPUT DATA

PROBLEM 4

WIDE FLANGE SECTION W14X90

AREA:	26.5000	THW:	.4400	THF:	.7100				
IY:	362.0000	SY:	49.8000	IZ:	999.0000	SZ:	143.0000	Z0:	14.5200
J:	4.0600	CW:	16043.6500	WN1:	48.3153				
SW2:	124.5230	E:	29000.0000	G:	11200.0000				
QY2:	33.2644	QY4:	77.3395	QZ2:	18.6940				

LENGTH: 480.0000

SECTIONS WHERE STRESSES ARE TO BE CHECKED

.0000

240.0000

480.0000

LEFT END FORCES

FX:	.0000	FY:	12.0000	FZ:	.0000
MX:	-97.0000	MY:	.0000	MZ:	-360.0000

1 SET OF APPLIED CONCENTRATED LOADS ARE AT 24.000 INCHES FROM LEFT END

FX:	.0000	FY:	.0000	FZ:	.0000
MX:	50.0000	MY:	.0000	MZ:	.0000

UNIFORM LOAD ON MEMBER IN Y-DIR

WY:	-.0500	LAY:	.0000	LBY:	480.0000
-----	--------	------	-------	------	----------

UNIFORM LOAD ON MEMBER IN Z-DIR

WZ:	.0000	LAZ:	.0000	LBZ:	.0000
-----	-------	------	-------	------	-------

UNIFORMLY DISTRIBUTED TORSIONAL LOAD IS

WX: .3000

MEMBER END CONDITIONS ARE FIX-FIX

DISTANCE FROM LEFT END OF MEMBER TO SECTION UNDER EXAMINATION IS .0000

SFY =	-12.0000	SFZ =	.0000
SHY2 =	-.5628	SHY4 =	-2.1114
SHZ2 =	.0000		
BMY =	.0000	BMZ =	960.0000
BSY1 =	.0000	BSZ1 =	-6.7133
AXSTR =	.0000		

TORSION MOMENT = 50.0000 LOCATION = 240.0000
PHI = .00000E+00 PHI1 = .00000E+00 PHI2 = .45082E-05 PHI3 = -.53733E-07

TOR. SHR. WEB =	.000000	TOR. SHR. FLANGE =	.000000
WARP. SHR. STR. =	.273293	WARP. NOR. STR. =	6.316594

UNIFORMLY DISTRIBUTED TORSIONAL MOMENT = .3000
PHI = .00000E+00 PHI1 = .00000E+00 PHI2 = .93305E-05 PHI3 = -.15475E-06

TOR. SHR. WEB =	.000000	TOR. SHR. FLANGE =	.000000
WARP. SHR. STR. =	.787083	WARP. NOR. STR. =	13.073370

COMBINED TORSIONAL INDUCED STRESSES

TOR. SHR. WEB =	.000000	TOR. SHR. FLANGE =	.000000
WARP. SHR. STR. =	1.060376	WARP. NOR. STR. =	19.389970

NORMAL STRESSES (KSI)

POINT	WITHOUT TORSION	TORSION ONLY	COMBINED STRESS
1	-6.713287	-19.389970	-26.103250
3	-6.713287	19.389970	12.676680
5	6.713287	19.389970	26.103250
7	6.713287	-19.389970	-12.676680

SHEAR STRESSES (KSI)

POINT	WITHOUT TORSION	TORSION ONLY	COMBINED STRESS
2L	-.562777	1.060376	.497599
2R	.562777	1.060376	1.623154
4L	-2.111371	.000000	-2.111371
4R	-2.111371	.000000	-2.111371
6L	.562777	-1.060376	-.497599
6R	-.562777	-1.060376	-1.623154

POINT LOCATIONS OF COMPUTED STRESSES

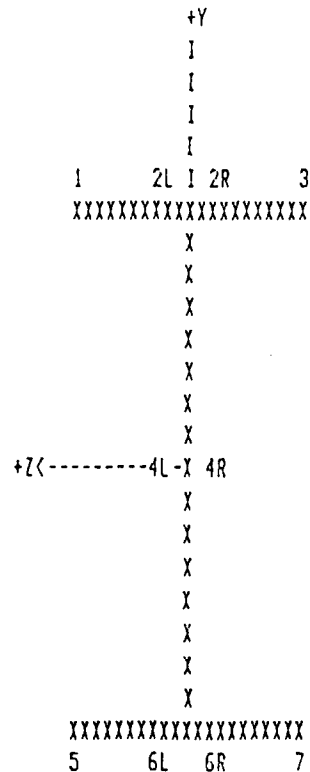

DISTANCE FROM LEFT END OF MEMBER TO SECTION UNDER EXAMINATION IS 240.0000

SFY =	.0000	SFZ =	.0000
SHY2 =	.0000	SHY4 =	.0000
SHZ2 =	.0000		
BMX =	.0000	BMZ =	2400.0000
BSY1 =	.0000	BSZ1 =	-16.7832
AXSTR =	.0000		

TORSION MOMENT = 50.0000 LOCATION = 240.0000
PHI = .39695E-01 PHI1 = .29067E-08 PHI2 = -.45081E-05 PHI3 = -.53732E-07

TOR. SHR. WEB =	.000014	TOR. SHR. FLANGE =	.000023
WARP. SHR. STR. =	.273291	WARP. NDR. STR. =	-6.316549

UNIFORMLY DISTRIBUTED TORSIONAL MOMENT = .3000
PHI = .57161E-01 PHI1 = -.14459E-09 PHI2 = -.36530E-05 PHI3 = -.15047E-13

TOR. SHR. WEB =	-.000001	TOR. SHR. FLANGE =	-.000001
WARP. SHR. STR. =	.000000	WARP. NDR. STR. =	-5.118407

COMBINED TORSIONAL INDUCED STRESSES

TOR. SHR. WEB =	.000014	TOR. SHR. FLANGE =	.000022
WARP. SHR. STR. =	.273292	WARP. NDR. STR. =	-11.434960

NORMAL STRESSES (KSI)

POINT	WITHOUT TORSION	TORSION ONLY	COMBINED STRESS
1	-16.783220	11.434960	-5.348261
3	-16.763220	-11.434960	-28.218170
5	16.783220	-11.434960	5.348261
7	16.783220	11.434960	28.218170

SHEAR STRESSES (KSI)

POINT	WITHOUT TORSION	TORSION ONLY	COMBINED STRESS
2L	.000000	.273313	.273313
2R	.000000	.273313	.273313
4L	.000000	-.000014	-.000014
4R	.000000	.000014	.000014
6L	.000000	-.273313	-.273313
6R	.000000	-.273313	-.273313

POINT LOCATIONS OF COMPUTED STRESSES

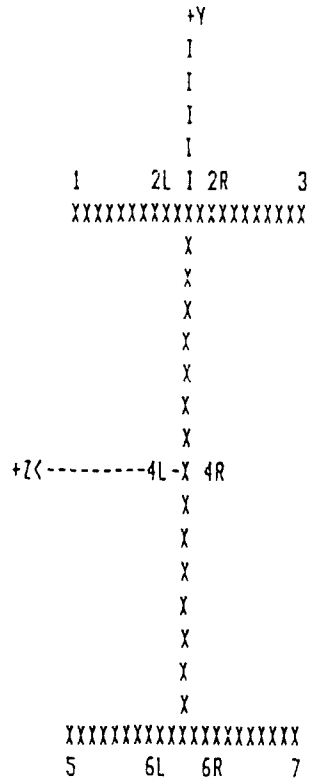

DISTANCE FROM LEFT END OF MEMBER TO SECTION UNDER EXAMINATION IS 480.0000

SFY =	12.0000	SFZ =	.0000
SHY2 =	.5628	SHY4 =	2.1114
SHZ2 =	.0000		
BMY =	.0000	BMZ =	960.0000
BSY1 =	.0000	BSZ1 =	-6.7133
AXSTR =	.0000		

TORSION MOMENT = 50.0000 LOCATION = 240.0000
PHI = .28276E-05 PHI1 = -.67223E-09 PHI2 = .45084E-05 PHI3 = .53733E-07

TOR. SHR. WEB =	-.000003	TOR. SHR. FLANGE =	-.000005
WARP. SHR. STR. =	-.273292	WARP. NOR. STR. =	6.316973

UNIFORMLY DISTRIBUTED TORSIONAL MOMENT = .3000
PHI = -.10165E-05 PHI1 = -.16137E-08 PHI2 = .93304E-05 PHI3 = .15475E-06

TOR. SHR. WEB =	-.000008	TOR. SHR. FLANGE =	-.000013
WARP. SHR. STR. =	-.787083	WARP. NOR. STR. =	13.073230

COMBINED TORSIONAL INDUCED STRESSES

TOR. SHR. WEB =	-.000011	TOR. SHR. FLANGE =	-.000018
WARP. SHR. STR. =	-1.060375	WARP. NOR. STR. =	13.330200

NORMAL STRESSES (KSI)

POINT	WITHOUT TORSION	TORSION ONLY	COMBINED STRESS
1	-6.713287	-19.390200	-26.103490
3	-6.713287	19.390200	12.676920
5	6.713287	19.390200	26.103490
7	6.713287	-19.390200	-12.676920

SHEAR STRESSES (KSI)

POINT	WITHOUT TORSION	TORSION ONLY	COMBINED STRESS
2L	.562777	-1.060393	-.497616
2R	-.562777	-1.060393	-1.623170
4L	2.111371	.000011	2.111382
4R	2.111371	-.000011	2.111360
6L	-.562777	1.060393	.497616
6R	.562777	1.060393	1.623170

POINT LOCATIONS OF COMPUTED STRESSES

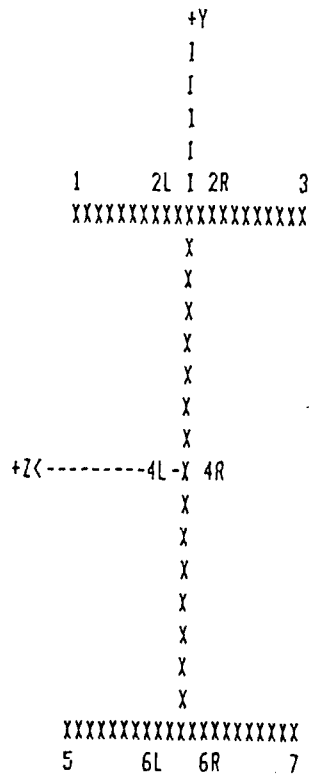

"TORSION" PROGRAM INPUT FILE

Problem: 5
Beam Selected: W8x15
End Conditions: Fixed-Free

'W-FLANGE' 'W8x15'
4.44 0.245 0.315
8.11 4.015
3.41 1.7
48.0 11.8
0.136 29000.0 11200.0
60.0
3
0.0 18.0 60.0
0.0 5.0 0.0
-30.0 0.0 -150.0
'FIX-FRE'
1
18.0 0.0 0.0 0.0 30.0 0.0 0.0
-0.0833 0.0 60.0
0.0 0.0 0.0
0.0 0.0
'Y'

INPUT DATA PROBLEM 5

WIDE FLANGE SECTION W8X15

AREA:	4.4400	THW:	.2450	THF:	.3150				
IY:	3.4100	SY:	1.7000	IZ:	48.0000	SZ:	11.8000	Z0:	4.0150
J:	.1360	CW:	51.6164	WN1:	7.8242				
SW2:	2.4739	E:	23000.0000	G:	11200.0000				
QY2:	2.3142	QY4:	6.6427	QZ2:	.6324				
LENGTH:	60.0000								

SECTIONS WHERE STRESSES ARE TO BE CHECKED

.0000
18.0000
60.0000

LEFT END FORCES

FX:	.0000	FY:	5.0000	FZ:	.0000
MX:	-30.0000	MY:	.0000	MZ:	-150.0000

1 SET OF APPLIED CONCENTRATED LOADS ARE AT 18.00 INCHES FROM LEFT END

FX:	.0000	FY:	.0000	FZ:	.0000
MX:	30.0000	MY:	.0000	MZ:	.0000

UNIFORM LOAD ON MEMBER IN Y-DIR

MY:	-.0833	LAY:	.0000	LBY:	60.0000
-----	--------	------	-------	------	---------

UNIFORM LOAD ON MEMBER IN Z-DIR

MZ:	.0000	LAZ:	.0000	LBZ:	.0000
-----	-------	------	-------	------	-------

UNIFORMLY DISTRIBUTED TORSIONAL LOAD IS

MX:	.0000	LX:	.0000
-----	-------	-----	-------

MEMBER END CONDITIONS ARE FIX-FRE

DISTANCE FROM LEFT END OF MEMBER TO SECTION UNDER EXAMINATION IS .0000

SFY =	-5.0000	SFZ =	.0000
SHY2 =	-.7653	SHY4 =	-2.8243
SHZ2 =	.0000		
BHY =	.0000	BMZ =	150.0000
BSY1 =	.0000	BSZ1 =	-12.7119
AXSTR =	.0000		

TORSION MOMENT = 30.0000 LOCATION = 18.0000
PHI = .00000E+00 PHI1 = .00000E+00 PHI2 = .27899E-03 PHI3 = -.20042E-04

TOR. SHR. WEB =	.000000	TOR. SHR. FLANGE =	.000000
WARP. SHR. STR. =	4.564575	WARP. NOR. STR. =	63.303330

COMBINED TORSIONAL INDUCED STRESSES

TOR. SHR. WEB =	.000000	TOR. SHR. FLANGE =	.000000
WARP. SHR. STR. =	4.564575	WARP. NOR. STR. =	63.303330

NORMAL STRESSES (KSI)

POINT	WITHOUT TORSION	TORSION ONLY	COMBINED STRESS
1	-12.711860	-63.303330	-76.015200
3	-12.711860	63.303330	50.591470
5	12.711860	63.303330	76.015200
7	12.711860	-63.303330	-50.591470

SHEAR STRESSES (KSI)

POINT	WITHOUT TORSION	TORSION ONLY	COMBINED STRESS
2L	-.765290	4.564575	3.799284
2R	.765290	4.564575	5.329865
4L	-2.824297	.000000	-2.824297
4R	-2.824297	.000000	-2.824297
6L	.765290	-4.564575	-3.799284
6R	-.765290	-4.564575	-5.329865

POINT LOCATIONS OF COMPUTED STRESSES

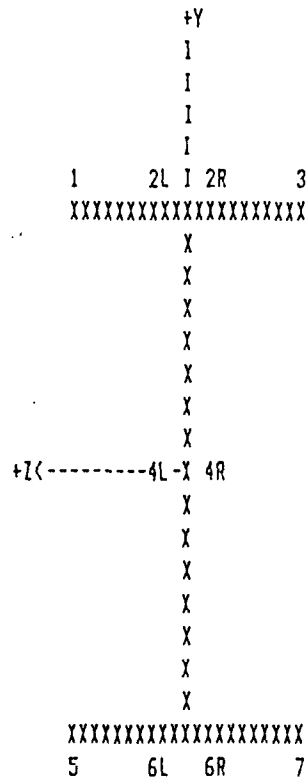

DISTANCE FROM LEFT END OF MEMBER TO SECTION UNDER EXAMINATION IS 18.0000

SFY =	-3.5001	SFZ =	.0000
SHY2 =	-.5357	SHY4 =	-1.9770
SHZ2 =	.0000		
BMX =	.0000	BMZ =	226.5005
BSY1 =	.0000	BSZ1 =	-19.1950
AXSTR =	.0000		

TORSION MOMENT = 30.0000 LOCATION = 18.0000
PHI = .26647E-01 PHI1 = .19654E-02 PHI2 = -.54646E-04 PHI3 = -.18042E-04

TOR. SHR. WEB =	5.393003	TOR. SHR. FLANGE =	6.933861
WARP. SHR. STR. =	4.109081	WARP. NOR. STR. =	-12.399340

COMBINED TORSIONAL INDUCED STRESSES

TOR. SHR. WEB =	5.393003	TOR. SHR. FLANGE =	6.933861
WARP. SHR. STR. =	4.109081	WARP. NOR. STR. =	-12.399340

NORMAL STRESSES (KSI)

POINT	WITHOUT TORSION	TORSION ONLY	COMBINED STRESS
1	-19.194960	12.399340	-6.795623
3	-19.194960	-12.399340	-31.594300
5	19.194960	-12.399340	6.795623
7	19.194960	12.399340	31.594300

SHEAR STRESSES (KSI)

POINT	WITHOUT TORSION	TORSION ONLY	COMBINED STRESS
2L	-.535712	11.042940	10.507230
2R	.535712	11.042940	11.578650
4L	-1.977042	-5.393003	-7.370045
4R	-1.977042	5.393003	3.415961
6L	.535712	-11.042940	-10.507230
6R	-.535712	-11.042940	-11.578650

POINT LOCATIONS OF COMPUTED STRESSES

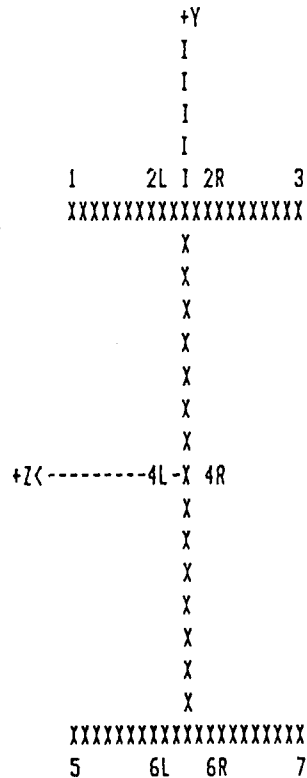

DISTANCE FROM LEFT END OF MEMBER TO SECTION UNDER EXAMINATION IS 60.0000

SFY =	-.0002	SFZ =	.0000
SHY2 =	.0000	SHY4 =	-.0001
SHZ2 =	.0000		
BMY =	.0000	BMZ =	300.0060
BSY1 =	.0000	BSZ1 =	-25.4242
AXSTR =	.0000		

TORSION MOMENT = 30.0000 LOCATION = 18.0000
PHI = .80349E-01 PHI1 = .96339E-03 PHI2 = .63497E-11 PHI3 = .98034E-06

TOR. SHR. WEB =	2.643553	TOR. SHR. FLANGE =	3.398853
WARP. SHR. STR. =	-.223275	WARP. NOR. STR. =	.000001

COMBINED TORSIONAL INDUCED STRESSES

TOR. SHR. WEB =	2.643553	TOR. SHR. FLANGE =	3.398853
WARP. SHR. STR. =	-.223275	WARP. NOR. STR. =	.000001

NORMAL STRESSES (KSI)

POINT	WITHOUT TORSION	TORSION ONLY	COMBINED STRESS
1	-25.424230	-.000001	-25.424240
3	-25.424230	.000001	-25.424230
5	25.424230	.000001	25.424240
7	25.424230	-.000001	25.424230

SHEAR STRESSES (KSI)

POINT	WITHOUT TORSION	TORSION ONLY	COMBINED STRESS
2L	-.000031	3.175578	3.175548
2R	.000031	3.175578	3.175609
4L	-.000113	-2.643553	-2.643666
4R	-.000113	2.643553	2.643440
6L	.000031	-3.175578	-3.175548
6R	-.000031	-3.175578	-3.175609

POINT LOCATIONS OF COMPUTED STRESSES

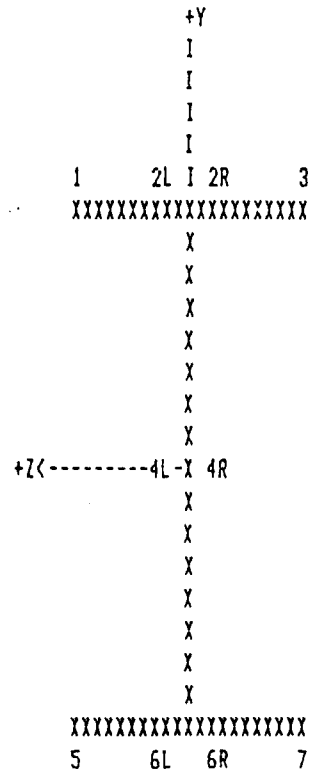

"TORSION" PROGRAM INPUT FILE

Problem: 6
Beam Selected: W10x49
End Conditions: Fixed-Free

'W-FLANGE' 'W10x49'
14.4 0.34 0.56
9.98 10.0
93.4 18.7
272.0 54.6
1.38 29000.0 11200.0
192.0
3
0.0 96.0 192.0
0.0 -2.0 0.0
-38.4 0.0 576.0
'FIX-FRE'
2
96.0 0.0 -2.0 0.0 0.0 0.0 0.0
192.0 0.0 4.0 0.0 0.0 0.0 0.0
0.0 0.0 0.0
0.0 0.0 0.0
0.4 96.0
'Y'

INPUT DATA

PROBLEM 6

WIDE FLANGE SECTION W10X49

AREA:	14.4000	THW:	.3400	THF:	.5600				
IY:	93.4000	SY:	18.7000	IZ:	272.0000	SZ:	54.6000	Z9:	10.0000
J:	1.3800	CW:	2070.5160	WNI:	23.5500				
SW2:	32.9700	E:	29000.0000	G:	11200.0000				
QY2:	12.7396	QY4:	29.7122	QZ2:	6.9919				

LENGTH: 192.0000

SECTIONS WHERE STRESSES ARE TO BE CHECKED

.0000
96.0000
192.0000

LEFT END FORCES

FX:	.0000	FY:	-2.0000	FZ:	.0000
MX:	-38.4000	MY:	.0000	MZ:	576.0000

1 SET OF APPLIED CONCENTRATED LOADS ARE AT 96.00 INCHES FROM LEFT END

FX:	.0000	FY:	-2.0000	FZ:	.0000
MX:	.0000	MY:	.0000	MZ:	.0000

2 SET OF APPLIED CONCENTRATED LOADS ARE AT 192.00 INCHES FROM LEFT END

FX:	.0000	FY:	4.0000	FZ:	.0000
MX:	.0000	MY:	.0000	MZ:	.0000

UNIFORM LOAD ON MEMBER IN Y-DIR

MY:	.0000	LAY:	.0000	LBZ:	.0000
-----	-------	------	-------	------	-------

UNIFORM LOAD ON MEMBER IN Z-DIR

MZ:	.0000	LAZ:	.0000	LBZ:	.0000
-----	-------	------	-------	------	-------

UNIFORMLY DISTRIBUTED TORSIONAL LOAD IS

MX:	.4000	LX:	96.0000
-----	-------	-----	---------

MEMBER END CONDITIONS ARE FIX-FRE

DISTANCE FROM LEFT END OF MEMBER TO SECTION UNDER EXAMINATION IS .0000

SFY =	2.0000	SFZ =	.0000
SHY2 =	.1673	SHY4 =	.6426
SHZ2 =	.0000		
BMY =	.0000	BMZ =	-576.0000
BSY1 =	.0000	BSZ1 =	10.5495
AXSTR =	.0000		

UNIFORMLY DISTRIBUTED TORSIONAL MOMENT = .40000000 ENDING AT 96.00000 FROM LEFT END

PHI = .00000E+00 PHI1 = .00000E+00 PHI2 = .19602E-04 PHI3 = -.63952E-06

TOR. SHR. WEB =	.000000	TOR. SHR. FLANGE =	.000000
WARP. SHR. STR. =	1.031902	WARP. NOR. STR. =	13.387470

COMBINED TORSIONAL INDUCED STRESSES

TOR. SHR. WEB =	.000000	TOR. SHR. FLANGE =	.000000
WARP. SHR. STR. =	1.091902	WARP. NOR. STR. =	13.387470

NORMAL STRESSES (KSI)

POINT	WITHOUT TORSION	TORSION ONLY	COMBINED STRESS
1	10.549450	-13.387470	-2.838023
3	10.549450	13.387470	23.936920
5	-10.549450	13.387470	2.838023
7	-10.549450	-13.387470	-23.936920

SHEAR STRESSES (KSI)

POINT	WITHOUT TORSION	TORSION ONLY	COMBINED STRESS
2L	.167274	1.091902	1.259176
2R	-.167274	1.091902	.924628
4L	.642566	.000000	.642566
4R	.642566	.000000	.642566
6L	-.167274	-1.091902	-1.259176
6R	.167274	-1.091902	-.924628

POINT LOCATIONS OF COMPUTED STRESSES

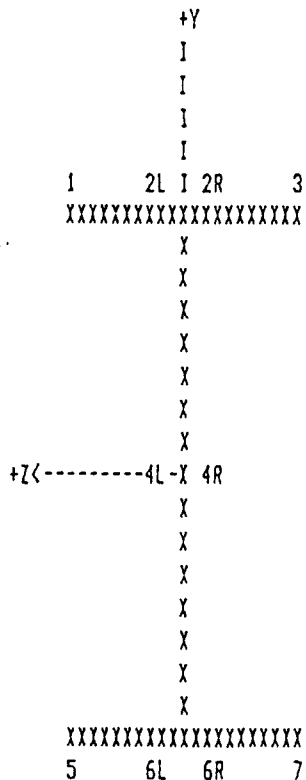

DISTANCE FROM LEFT END OF MEMBER TO SECTION UNDER EXAMINATION IS 96.0000

SFY =	2.0000	SFZ =	.0000
SHY2 =	.1673	SHY4 =	.6426
SHZ2 =	.0000		
BMY =	.0000	BMZ =	-768.0000
BSY1 =	.0000	BSZ1 =	14.0659
AXSTR =	.0000		

UNIFORMLY DISTRIBUTED TORSIONAL MOMENT = .40000000 ENDING AT 96.00000 FROM LEFT END

PHI= .29039E-01 PHI1= .24734E-03 PHI2= -.36197E-05 PHI3= .63667E-07

TOR. SHR. WEB =	.941862	TOR. SHR. FLANGE =	1.551303
WARP. SHR. STR. =	-.108703	WARP. NOR. STR. =	-2.472049

COMBINED TORSIONAL INDUCED STRESSES

TOR. SHR. WEB =	.941862	TOR. SHR. FLANGE =	1.551303
WARP. SHR. STR. =	-.108703	WARP. NOR. STR. =	-2.472049

NORMAL STRESSES (KSI)

POINT	WITHOUT TORSION	TORSION ONLY	COMBINED STRESS
1	14.065930	2.472049	16.537980
3	14.065930	-2.472049	11.593890
5	-14.065930	-2.472049	-16.537980
7	-14.065930	2.472049	-11.593890

SHEAR STRESSES (KSI)

POINT	WITHOUT TORSION	TORSION ONLY	COMBINED STRESS
2L	.167274	1.442600	1.609875
2R	-.167274	1.442600	1.275326
4L	.642566	-.941862	-.299297
4R	.642566	.941862	1.584428
6L	-.167274	-1.442600	-1.609875
6R	.167274	-1.442600	-1.275326

POINT LOCATIONS OF COMPUTED STRESSES

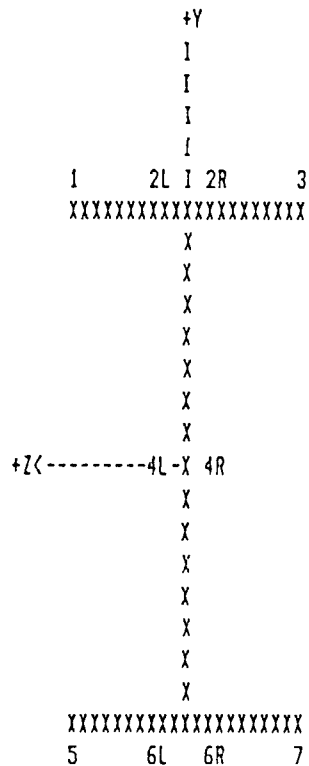

DISTANCE FROM LEFT END OF MEMBER TO SECTION UNDER EXAMINATION IS 192.0000

SFY =	4.0000	SFZ =	.0000
SHY2 =	.3345	SHY4 =	1.2851
SHZ2 =	.0000		
BMY =	.0000	BNZ =	-1152.0000
BSY1 =	.0000	BSZ1 =	21.0389
AXSTR =	.0000		

UNIFORMLY DISTRIBUTED TORSIONAL MOMENT = .40000000 ENDING AT 96.00000 FROM LEFT END

PHI= .43101E-01 PHI1= .10137E-03 PHI2= -.26550E-11 PHI3= .26093E-07

TOR. SHR. WEB =	.386014	TOR. SHR. FLANGE =	.635787
WARP. SHR. STR. =	-.044551	WARP. NDR. STR. =	-.000002

COMBINED TORSIONAL INDUCED STRESSES

TOR. SHR. WEB =	.386014	TOR. SHR. FLANGE =	.635787
WARP. SHR. STR. =	-.044551	WARP. NDR. STR. =	-.000002

NORMAL STRESSES (KSI)

POINT	WITHOUT TORSION	TORSION ONLY	COMBINED STRESS
1	21.098900	.000002	21.098900
3	21.098900	-.000002	21.098900
5	-21.098900	-.000002	-21.098900
7	-21.098900	.000002	-21.098900

SHEAR STRESSES (KSI)

POINT	WITHOUT TORSION	TORSION ONLY	COMBINED STRESS
2L	.334549	.591236	.925785
2R	-.334549	.591236	.256688
4L	1.285131	-.386014	.899118
4R	1.285131	.386014	1.671145
6L	-.334549	-.591236	-.925785
6R	.334549	-.591236	-.256688

POINT LOCATIONS OF COMPUTED STRESSES

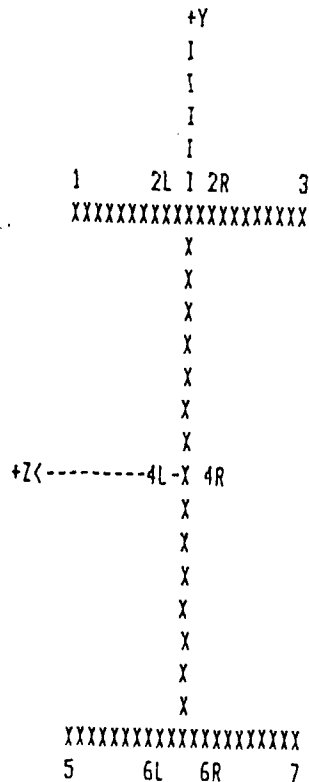

"TORSION" PROGRAM INPUT FILE

Problem: 7
Beam Selected: W6x15
End Conditions: Fixed-Free

'W-FLANGE' 'W6x15'
4.43 0.23 0.26
5.99 5.99
9.32 3.11
29.1 9.72
0.10 29000.0 11200.0
42.0
3
0.0 12.6 42.0
0.0 0.0 0.0
-40.0 0.0 0.0
'FIX-FRE'
1
12.6 0.0 0.0 0.0 40.0 0.0 0.0
0.0 0.0 0.0
0.0 0.0 0.0
0.0 0.0
'Y'

INPUT DATA

PROBLEM 7

WIDE FLANGE SECTION W6X15

AREA:	4.4300	THW:	.2300	THF:	.2600				
IY:	9.3200	SY:	3.1100	IZ:	29.1000	SZ:	9.7200	ZD:	5.9900
J:	.1000	CW:	76.4455	WN1:	8.5807				
SW2:	3.3409	E:	29000.0000	G:	11200.0000				
QY2:	2.1453	QY4:	5.3222	QZ2:	1.1644				
LENGTH:	42.0000								

SECTIONS WHERE STRESSES ARE TO BE CHECKED

.0000
12.6000
42.0000

LEFT END FORCES

FX:	.0000	FY:	.0000	FZ:	.0000
MX:	-40.0000	MY:	.0000	MZ:	.0000

1 SET OF APPLIED CONCENTRATED LOADS ARE AT 12.60 INCHES FROM LEFT END

FX:	.0000	FY:	.0000	FZ:	.0000
MX:	40.0000	MY:	.0000	MZ:	.0000

UNIFORM LOAD ON MEMBER IN Y-DIR

WY:	.0000	LAY:	.0000	LEY:	.0000
-----	-------	------	-------	------	-------

UNIFORM LOAD ON MEMBER IN Z-DIR

WZ:	.0000	LAZ:	.0000	LBZ:	.0000
-----	-------	------	-------	------	-------

UNIFORMLY DITRIBUTED TORSIONAL LOAD IS

WX:	.0000	LX:	.0000
-----	-------	-----	-------

MEMBER END CONDITIONS ARE FIX-FRE

DISTANCE FROM LEFT END OF MEMBER TO SECTION UNDER EXAMINATION IS .0000

SFY =	.0000	SFZ =	.0000
SHY2 =	.0000	SHY4 =	.0000
SHZ2 =	.0000		
BHY =	.0000	BMZ =	.0000
BSY1 =	.0000	BSZ1 =	.0000
AXSTR =	.0000		

TORSION MOMENT = 40.0000 LOCATION = 12.6000
PHI= .00000E+00 PHI1= .00000E+00 PHI2= .20651E-03 PHI3= -.16043E-04

TOR. SHR. WEB =	.000000	TOR. SHR. FLANGE =	.000000
WARP. SHR. STR. =	6.723516	WARP. NOR. STR. =	51.387050

COMBINED TORSIONAL INDUCED STRESSES

TOR. SHR. WEB =	.000000	TOR. SHR. FLANGE =	.000000
WARP. SHR. STR. =	6.723516	WARP. NOR. STR. =	51.387050

NORMAL STRESSES (KSI)

POINT	WITHOUT TORSION	TORSION ONLY	COMBINED STRESS
1	.000000	-51.387050	-51.387050
3	.000000	51.387050	51.387050
5	.000000	51.387050	51.387050
7	.000000	-51.387050	-51.387050

SHEAR STRESSES (KSI)

POINT	WITHOUT TORSION	TORSION ONLY	COMBINED STRESS
2L	.000000	6.723516	6.723516
2R	.000000	6.723516	6.723516
4L	.000000	.000000	.000000
4R	.000000	.000000	.000000
6L	.000000	-6.723516	-6.723516
6R	.000000	-6.723516	-6.723516

POINT LOCATIONS OF COMPUTED STRESSES

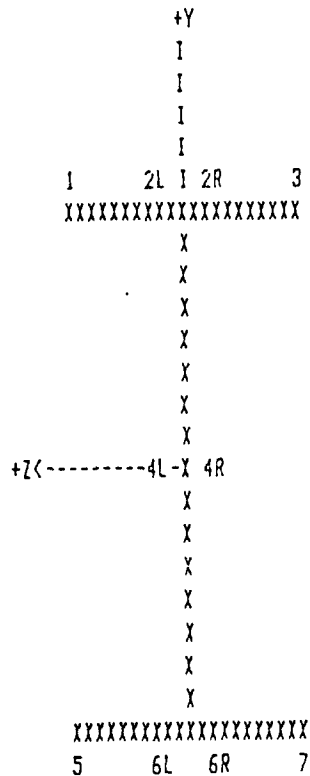

DISTANCE FROM LEFT END OF MEMBER TO SECTION UNDER EXAMINATION IS 12.6000

SFY =	.0000	SFZ =	.0000
SHY2 =	.0000	SHY4 =	.0000
SHZ2 =	.0000		
BMY =	.0000	BMZ =	.0000
BSY1 =	.0000	BSZ1 =	.0000
AXSTR =	.0000		

TORSION MOMENT = 40.0000 LOCATION = 12.6000
PHI = .10463E-01 PHI1 = .11951E-02 PHI2 = -.15550E-04 PHI3 = -.17439E-04

TOR. SHR. WEB =	3.078450	TOR. SHR. FLANGE =	3.479986
WARP. SHR. STR. =	6.498538	WARP. NDR. STR. =	-3.869450

COMBINED TORSIONAL INDUCED STRESSES

TOR. SHR. WEB =	3.078450	TOR. SHR. FLANGE =	3.479986
WARP. SHR. STR. =	6.498538	WARP. NOR. STR. =	-3.869450

NORMAL STRESSES (KSI)

POINT	WITHOUT TORSION	TORSION ONLY	COMBINED STRESS
1	.000000	3.869450	3.869450
3	.000000	-3.869450	-3.869450
5	.000000	-3.869450	-3.869450
7	.000000	3.869450	3.869450

SHEAR STRESSES (KSI)

POINT	WITHOUT TORSION	TORSION ONLY	COMBINED STRESS
2L	.000000	9.978524	9.978524
2R	.000000	9.978524	9.978524
4L	.000000	-3.078450	-3.078450
4R	.000000	3.078450	3.078450
6L	.000000	-9.978524	-9.978524
6R	.000000	-9.978524	-9.978524

POINT LOCATIONS OF COMPUTED STRESSES

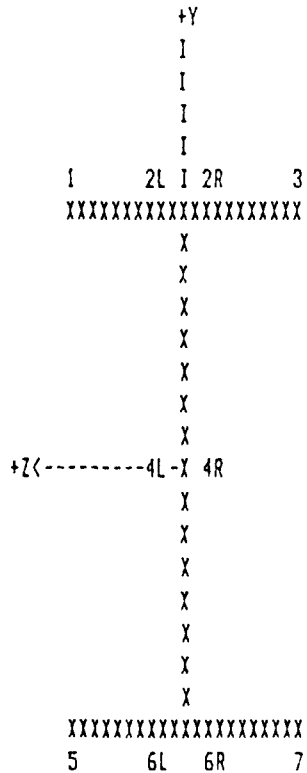

DISTANCE FROM LEFT END OF MEMBER TO SECTION UNDER EXAMINATION IS 42.0000

SFY =	.0000	SFZ =	.0000
SHY2 =	.0000	SHY4 =	.0000
SHZ2 =	.0000		
BMY =	.0000	BMZ =	.0000
BSY1 =	.0000	BSZ1 =	.0000
AXSTR =	.0000		

TORSION MOMENT = 40.0000 LOCATION = 12.6000
PHI = .41242E-01 PHI1 = .97444E-03 PHI2 = .23221E-12 PHI3 = .49229E-06

TOR. SHR. WEB =	2.510150	TOR. SHR. FLANGE =	2.837561
WARP. SHR. STR. =	-.183446	WARP. NOR. STR. =	.000000

COMBINED TORSIONAL INDUCED STRESSES

TOR. SHR. WEB =	2.510150	TOR. SHR. FLANGE =	2.837561
WARP. SHR. STR. =	-.183446	WARP. NOR. STR. =	.000000

NORMAL STRESSES (KSI)

POINT	WITHOUT TORSION	TORSION ONLY	COMBINED STRESS
1	.000000	.000000	.000000
3	.000000	.000000	.000000
5	.000000	.000000	.000000
7	.000000	.000000	.000000

SHEAR STRESSES (KSI)

POINT	WITHOUT TORSION	TORSION ONLY	COMBINED STRESS
2L	.000000	2.654115	2.654115
2R	.000000	2.654115	2.654115
4L	.000000	-2.510150	-2.510150
4R	.000000	2.510150	2.510150
6L	.000000	-2.654115	-2.654115
6R	.000000	-2.654115	-2.654115

POINT LOCATIONS OF COMPUTED STRESSES

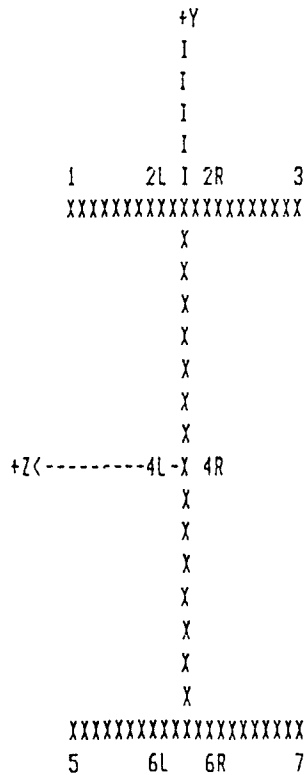

"TORSION" PROGRAM INPUT FILE

Problem: 8
Beam Selected: W8x67
End Conditions: Fixed-Free

'W-FLANGE' 'W8x67'
19.7 0.57 0.935
9.0 8.28
88.6 21.4
272.0 60.4
5.05 29000.0 11200.0
108.0
3
0.0 32.4 108.0
0.0 0.0 0.0
5.4 0.0 0.0
'FIX-FRE'
0
0.0 0.0 0.0 0.0 0.0 0.0 0.0
0.0 0.0 0.0
0.0 0.0 0.0
-0.2 108.0
0.5 32.4
'Y'

INPUT DATA

PROBLEM 8

WIDE FLANGE SECTION WBX67

AREA:	19.7000	THW:	.5700	THF:	.9350				
IY:	88.6000	SY:	21.4000	IZ:	272.0000	SZ:	60.4000	ZD:	8.2800
J:	5.0500	CW:	1438.4680	WN1:	16.6945				
SW2:	32.3115	E:	29000.0000	G:	11200.0000				
QY2:	14.5348	QY4:	34.8409	QZ2:	7.9748				

LENGTH: 108.0000

SECTIONS WHERE STRESSES ARE TO BE CHECKED

.0000

32.4000

108.0000

LEFT END FORCES

FX:	.0000	FY:	.0000	FZ:	.0000
MX:	5.4000	MY:	.0000	MZ:	.0000

UNIFORM LOAD ON MEMBER IN Y-DIR

WY:	.0000	LAY:	.0000	LBZ:	.0000
-----	-------	------	-------	------	-------

UNIFORM LOAD ON MEMBER IN Z-DIR

WZ:	.0000	LAZ:	.0000	LBZ:	.0000
-----	-------	------	-------	------	-------

UNIFORMLY DISTRIBUTED TORSIONAL LOAD IS

WX:	.5000	LX:	32.4000
-----	-------	-----	---------

MEMBER END CONDITIONS ARE FIX-FRE

DISTANCE FROM LEFT END OF MEMBER TO SECTION UNDER EXAMINATION IS .0000

SFY =	.0000	SFZ =	.0000
SHY2 =	.0000	SHY4 =	.0000
SHZ2 =	.0000		
BMX =	.0000	BMZ =	.0000
BSY1 =	.0000	BSZ1 =	.0000
AXSTR =	.0000		

UNIFORMLY DISTRIBUTED TORSIONAL MOMENT = .50000000 ENDING AT 32.40000 FROM LEFT END

PHI= .00000E+00 PHI1= .00000E+00 PHI2= .43895E-05 PHI3= -.38834E-06

TOR. SHR. WEB =	.000000	TOR. SHR. FLANGE =	.000000
WARP. SHR. STR. =	.389188	WARP. NOR. STR. =	2.125153

COMBINED TORSIONAL INDUCED STRESSES

TOR. SHR. WEB =	.000000	TOR. SHR. FLANGE =	.000000
WARP. SHR. STR. =	.389188	WARP. NOR. STR. =	2.125153

NORMAL STRESSES (KSI)

POINT	WITHOUT TORSION	TORSION ONLY	COMBINED STRESS
1	.000000	-2.125153	-2.125153
3	.000000	2.125153	2.125153
5	.000000	2.125153	2.125153
7	.000000	-2.125153	-2.125153

SHEAR STRESSES (KSI)

POINT	WITHOUT TORSION	TORSION ONLY	COMBINED STRESS
2L	.000000	.389188	.389188
2R	.000000	.389188	.389188
4L	.000000	.000000	.000000
4R	.000000	.000000	.000000
6L	.000000	-.389188	-.389188
6R	.000000	-.389188	-.389188

POINT LOCATIONS OF COMPUTED STRESSES

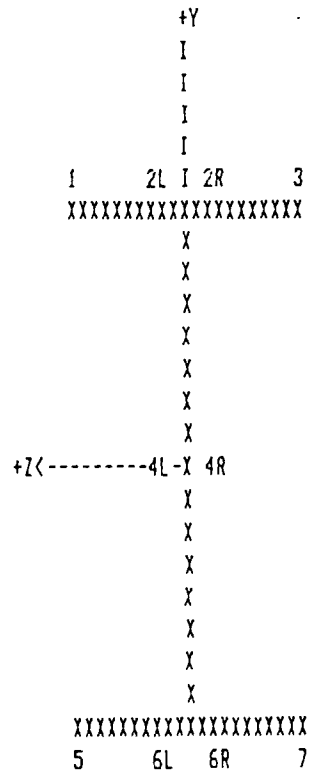

DISTANCE FROM LEFT END OF MEMBER TO SECTION UNDER EXAMINATION IS 32.4000

SFY =	.0000	SFZ =	.0000
SHY2 =	.0000	SHY4 =	.0000
SHZ2 =	.0000		
BHY =	.0000	BMZ =	.0000
BSY1 =	.0000	BSZ1 =	.0000
AXSTR =	.0000		

UNIFORMLY DISTRIBUTED TORSIONAL MOMENT = .50000000 ENDING AT 32.40000 FROM LEFT END

PHI= .80419E-03 PHI1= .22202E-04 PHI2= -.81129E-06 PHI3= .30102E-07

TOR. SHR. WEB =	.141736	TOR. SHR. FLANGE =	.232496
WARP. SHR. STR. =	-.030168	WARP. NOR. STR. =	-.392778

COMBINED TORSIONAL INDUCED STRESSES

TOR. SHR. WEB =	.141736	TOR. SHR. FLANGE =	.232496
WARP. SHR. STR. =	-.030168	WARP. NOR. STR. =	-.392778

NORMAL STRESSES (KSI)

POINT	WITHOUT TORSION	TORSION ONLY	COMBINED STRESS
1	.000000	.392778	.392778
3	.000000	-.392778	-.392778
5	.000000	-.392778	-.392778
7	.000000	.392778	.392778

SHEAR STRESSES (KSI)

POINT	WITHOUT TORSION	TORSION ONLY	COMBINED STRESS
2L	.000000	.202329	.202329
2R	.000000	.202329	.202329
4L	.000000	-.141736	-.141736
4R	.000000	.141736	.141736
6L	.000000	-.202329	-.202329
6R	.000000	-.202329	-.202329

POINT LOCATIONS OF COMPUTED STRESSES

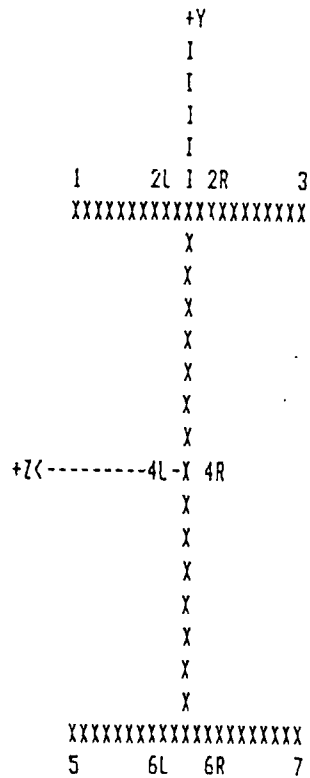

DISTANCE FROM LEFT END OF MEMBER TO SECTION UNDER EXAMINATION IS 108.0000

SFY =	.0000	SF2 =	.0000
SHY2 =	.0000	SHY4 =	.0000
SHZ2 =	.0000		
BHY =	.0000	BMZ =	.0000
BSY1 =	.0000	BSZ1 =	.0000
AXSTR =	.0000		

UNIFORMLY DISTRIBUTED TORSIONAL MOMENT = .50000000 ENDING AT 32.40000 FROM LEFT END

PHI= .14026E-02 PHI1= .27341E-05 PHI2= -.13441E-11 PHI3= .37071E-08

TOR. SHR. WEB =	.017455	TOR. SHR. FLANGE =	.028632
WARP. SHR. STR. =	-.003715	WARP. NOR. STR. =	-.000001

COMBINED TORSIONAL INDUCED STRESSES

TOR. SHR. WEB =	.017455	TOR. SHR. FLANGE =	.028632
WARP. SHR. STR. =	-.003715	WARP. NOR. STR. =	-.000001

NORMAL STRESSES (KSI)

POINT	WITHOUT TORSION	TORSION ONLY	COMBINED STRESS
1	.000000	.000001	.000001
3	.000000	-.000001	-.000001
5	.000000	-.000001	-.000001
7	.000000	.000001	.000001

SHEAR STRESSES (KSI)

POINT	WITHOUT TORSION	TORSION ONLY	COMBINED STRESS
2L	.000000	.024917	.024917
2R	.000000	.024917	.024917
4L	.000000	-.017455	-.017455
4R	.000000	.017455	.017455
6L	.000000	-.024917	-.024917
6R	.000000	-.024917	-.024917

POINT LOCATIONS OF COMPUTED STRESSES

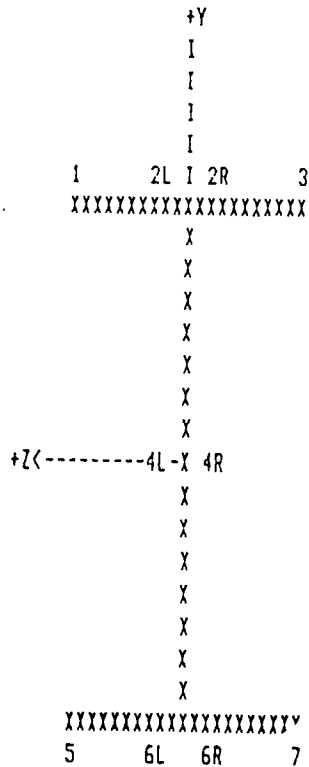

"TORSION" PROGRAM INPUT FILE

Problem: 9
Beam Selected: C10x20
End Conditions: Fixed-Free

'CHANNELS' 'C10x20'
5.88 0.379 0.436
10.0 2.739 0.606
2.81 1.32 4.637
78.9 15.8
0.370 29000.0 11200.0
60.0
3
0.0 18.0 60.0
0.0 5.0 0.0
-30.0 0.0 -150.0
'FIX-FRE'
1
18.0 0.0 0.0 0.0 30.0 0.0 0.0
-0.0833 0.0 60.0
0.0 0.0 0.0
0.0 0.0
'Y'

INPUT DATA PROBLEM 9 - Part (a)

CHANNEL SECTION C10X20

AREA:	5.8800	THW:	.3790	THF:	.4360		
IY:	2.8100	SY:	1.3200	SYS:	4.6370		
IZ:	78.9000	SZ:	15.8000	ZD:	2.7330		
J:	.3700	CW:	56.9206	WN1:	8.2423	WN3:	3.9494
SW2:	3.0970	SW3:	2.3859	SW4:	-1.1330		
E:	29000.0000	G:	11200.0000				
QY2:	4.4472	QY3:	5.3156	QY4:	3.6490		
QZ2:	.9918	QZ3:	.9540				

LENGTH: 60.0000

SECTIONS WHERE STRESSES ARE TO BE CHECKED

.0000
18.0000
60.0000

LEFT END FORCES

FX:	.0000	FY:	5.0000	FZ:	.0000
MX:	-30.0000	MY:	.0000	MZ:	-150.0000

1 SET OF APPLIED CONCENTRATED LOADS ARE AT 18.00 INCHES FROM LEFT END

FX:	.0000	FY:	.0000	FZ:	.0000
MX:	30.0000	MY:	.0000	MZ:	.0000

UNIFORM LOAD ON MEMBER IN Y-DIR

NY:	-.0833	LAY:	.0000	LBY:	60.0000
-----	--------	------	-------	------	---------

UNIFORM LOAD ON MEMBER IN Z-DIR

NZ:	.0000	LAZ:	.0000	LBZ:	.0000
-----	-------	------	-------	------	-------

UNIFORMLY DISTRIBUTED TORSIONAL LOAD IS

WX:	.0000	LX:	.0000
-----	-------	-----	-------

MEMBER END CONDITIONS ARE FIX-FRE

DISTANCE FROM LEFT END OF MEMBER TO SECTION UNDER EXAMINATION IS .0000

SFY =	-5.0000	SFZ =	.0000
SHY2 =	.6464	SHY3 =	.7726
SHY4 =	-1.6134	SHZ3 =	.0000
SHZ2 =	.0000	BNZ =	150.0000
BNY =	.0000	BSY3 =	.0000
BSY1 =	.0000	BSZ3 =	-9.4937
BSZ1 =	-9.4937		
AXSTR =	.0000		

TORSION MOMENT = 30.0000 LOCATION = 18.0000
PHI = .00000E+00 PHI1 = .00000E+00 PHI2 = .21630E-03 PHI3 = -.18174E-04

TOR. SHR. WEB =	.000000	TOR. SHR. FLANGE =	.000000		
WARP. SHR. STR. AT 2 =	3.743765	WARP. SHR. STR. AT 3 =	2.884202	WARP. SHR. STR. AT 4	-1.658987
WARP. NOR. STR. AT 1 =	51.701370	WARP. NOR. STR. AT 3 =	24.773460		

COMBINED TORSIONAL INDUCED STRESSES

TOR. SHR. WEB =	.000000	TOR. SHR. FLANGE =	.000000		
WARP. SHR. STR. AT 2 =	3.743765	WARP. SHR. STR. AT 3 =	2.884202	WARP. SHR. STR. AT 4	-1.658987
WARP. NOR. STR. AT 1 =	51.701370	WARP. NOR. STR. AT 3 =	24.773460		

NORMAL STRESSES (KSI)

POINT	WITHOUT TORSION	TORSION ONLY	COMBINED STRESS
1	-9.493670	51.701370	42.207700
3	-9.493670	-24.773460	-34.267130
5	9.493670	24.773460	34.267130
7	9.493670	-51.701370	-42.207700

SHEAR STRESSES (KSI)

POINT	WITHOUT TORSION	TORSION ONLY	COMBINED STRESS
2	.646388	3.743765	4.390153
2I	.646388	3.743765	4.390153
3	.772605	2.884202	3.656807
3I	.772605	2.884202	3.656807
4	-1.613375	-1.658987	-3.272361
4I	-1.613375	-1.658987	-3.272361
5	-.772605	-2.884202	-3.656807
5I	-.772605	-2.884202	-3.656807
6	-.646388	-3.743765	-4.390153
6I	-.646388	-3.743765	-4.390153

POINT LOCATIONS OF COMPUTED STRESSES

```

      +Y
      I
      I
      I
      I
      I
      3 2 1
      XXXXXXXXXXXX
      X I
      X I
      X I
      X I
      X I
      X I
      X I
      X I
      +Z<-----4-X---
      X
      X
      X
      X
      X
      X
      XXXXXXXXXXXX
      S 6 7
  
```

DISTANCE FROM LEFT END OF MEMBER TO SECTION UNDER EXAMINATION IS 18.0000

SFY =	-3.5001	SFZ =	.0000
SHY2 =	.4525	SHY3 =	.5408
SHY4 =	-1.1294	SHZ3 =	.0000
SHZ2 =	.0000		
BMZ =	.0000	BMZ =	226.5005
BSY1 =	.0000	BSY3 =	.0000
BSZ1 =	-14.3355	BSZ3 =	-14.3355
AXSTR =	.0000		

TORSION MOMENT = 30.0000 LOCATION = 18.0000
PHI = .19083E-01 PHI1 = .12938E-02 PHI2 = -.62927E-04 PHI3 = -.14526E-04

TOR. SHR. WEB =	5.492007	TOR. SHR. FLANGE =	6.317981		
WARP. SHR. STR. AT 2 =	3.074681	WARP. SHR. STR. AT 3 =	2.368738	WARP. SHR. STR. AT 4 =	-1.352493
WARP. NOR. STR. AT 1 =	-15.041270	WARP. NOR. STR. AT 3 =	-7.207242		

COMBINED TORSIONAL INDUCED STRESSES

TOR. SHR. WEB =	5.492007	TOR. SHR. FLANGE =	6.317981		
WARP. SHR. STR. AT 2 =	3.074681	WARP. SHR. STR. AT 3 =	2.368738	WARP. SHR. STR. AT 4 =	-1.352493
WARP. NOR. STR. AT 1 =	-15.041270	WARP. NOR. STR. AT 3 =	-7.207242		

NORMAL STRESSES (KSI)

POINT	WITHOUT TORSION	TORSION ONLY	COMBINED STRESS
1	-14.335480	-15.041270	-29.376750
3	-14.335480	7.207242	-7.128235
5	14.335480	-7.207242	7.128235
7	14.335480	15.041270	29.376750

SHEAR STRESSES (KSI)

POINT	WITHOUT TORSION	TORSION ONLY	COMBINED STRESS
2	.452480	9.392661	9.845140
2I	.452480	-3.243300	-2.790821
3	.540833	8.686719	9.227552
3I	.540833	-3.949242	-3.408410
4	-1.129382	-6.854500	-7.983881
4I	-1.129382	4.129514	3.000132
5	-.540833	-8.686719	-9.227552
5I	-.540833	3.949242	3.408410
6	-.452480	-9.392661	-9.845140
6I	-.452480	3.243300	2.790821

POINT LOCATIONS OF COMPUTED STRESSES

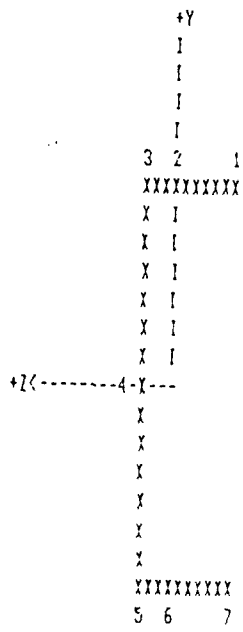

DISTANCE FROM LEFT END OF MEMBER TO SECTION UNDER EXAMINATION IS 60.0000

SFY =	-.0002	SFZ =	.0000
SHY2 =	.0000	SHY3 =	.0000
SHY4 =	-.0001	SHZ3 =	.0000
SHZ2 =	.0000		
BHY =	.0000	BHZ =	300.0060
BSY1 =	.0000	BSY3 =	.0000
BSZ1 =	-18.9877	BSZ3 =	-18.9877
AXSTR =	.0000		

TORSION MOMENT = 30.0000 LOCATION = 18.0000
PHI = .44149E-01 PHI1 = .31087E-03 PHI2 = -.59204E-10 PHI3 = .78042E-06

TOR. SHR. WEB =	1.319572	TOR. SHR. FLANGE =	1.518031		
WARP. SHR. STR. AT 2 =	-.160762	WARP. SHR. STR. AT 3 =	-.123851	WARP. SHR. STR. AT 4	.071239
WARP. NOR. STR. AT 1 =	-.000014	WARP. NOR. STR. AT 3 =	-.000007		

COMBINED TORSIONAL INDUCED STRESSES

TOR. SHR. WEB =	1.319572	TOR. SHR. FLANGE =	1.518031		
WARP. SHR. STR. AT 2 =	-.160762	WARP. SHR. STR. AT 3 =	-.123851	WARP. SHR. STR. AT 4	.071239
WARP. NOR. STR. AT 1 =	-.000014	WARP. NOR. STR. AT 3 =	-.000007		

INPUT DATA PROBLEM 9 - Part (b)

WIDE FLANGE SECTION W8X67

AREA:	19.7000	THW:	.5700	THF:	.9350				
IY:	88.6000	SY:	21.4000	IZ:	272.0000	SZ:	60.4000	ZD:	6.2800
J:	5.0500	CW:	1438.4680	WN1:	16.6945				
SW2:	32.3115	E:	29000.0000	G:	11200.0000				
QY2:	14.5348	QY4:	34.8409	QZ2:	7.9748				

LENGTH: 108.0000

SECTIONS WHERE STRESSES ARE TO BE CHECKED

.0000
32.4000
108.0000

LEFT END FORCES

FX:	.0000	FY:	.0000	FZ:	.0000
MX:	5.4000	MY:	.0000	MZ:	.0000

UNIFORM LOAD ON MEMBER IN Y-DIR

WY:	.0000	LAY:	.0000	LBY:	.0000
-----	-------	------	-------	------	-------

UNIFORM LOAD ON MEMBER IN Z-DIR

WZ:	.0000	LAZ:	.0000	LBZ:	.0000
-----	-------	------	-------	------	-------

UNIFORMLY DISTRIBUTED TORSIONAL LOAD IS

MX:	-.2000	LX:	108.0000
-----	--------	-----	----------

MEMBER END CONDITIONS ARE FIX-FRE

DISTANCE FROM LEFT END OF MEMBER TO SECTION UNDER EXAMINATION IS .0000

SFY =	.0000	SFZ =	.0000
SHY2 =	.0000	SHY4 =	.0000
SHZ2 =	.0000		
BMY =	.0000	BHZ =	.0000
BSY1 =	.0000	BSZ1 =	.0000
AXSTR =	.0000		

UNIFORMLY DISTRIBUTED TORSIONAL MOMENT = -.20000000 ENDING AT 108.00000 FROM LEFT END

PHI= .00000E+00 PHI1= .00000E+00 PHI2= -.10649E-04 PHI3= .51779E-06

TOR. SHR. WEB =	.000000	TOR. SHR. FLANGE =	.000000
WARP. SHR. STR. =	-.518918	WARP. NOR. STR. =	-5.155473

COMBINED TORSIONAL INDUCED STRESSES

TOR. SHR. WEB =	.000000	TOR. SHR. FLANGE =	.000000
WARP. SHR. STR. =	-.518918	WARP. NOR. STR. =	-5.155473

NORMAL STRESSES (KSI)

POINT	WITHOUT TORSION	TORSION ONLY	COMBINED STRESS
1	.000000	5.155473	5.155473
3	.000000	-5.155473	-5.155473
5	.000000	-5.155473	-5.155473
7	.000000	5.155473	5.155473

SHEAR STRESSES (KSI)

POINT	WITHOUT TORSION	TORSION ONLY	COMBINED STRESS
2L	.000000	-.518918	-.518918
2R	.000000	-.518918	-.518918
4L	.000000	.000000	.000000
4R	.000000	.000000	.000000
6L	.000000	.518918	.518918
6R	.000000	.518918	.518918

POINT LOCATIONS OF COMPUTED STRESSES

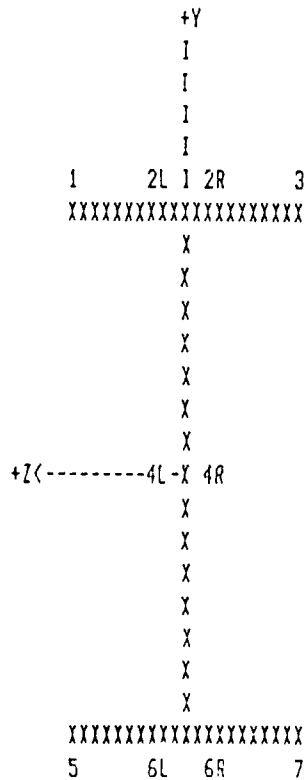

DISTANCE FROM LEFT END OF MEMBER TO SECTION UNDER EXAMINATION IS 32.4000

SFY =	.0000	SFZ =	.0000
SHY2 =	.0000	SHY4 =	.0000
SHZ2 =	.0000		
BHY =	.0000	BHZ =	.0000
BSY1 =	.0000	BSZ1 =	.0000
AXSTR =	.0000		

UNIFORMLY DISTRIBUTED TORSIONAL MOMENT = -.20000000 ENDING AT 108.00000 FROM LEFT END

PHI= -.33640E-02 PHI1= -.15648E-03 PHI2= -.94979E-06 PHI3= .15029E-06

TOR. SHR. WEB =	-.998990	TOR. SHR. FLANGE =	-1.638695
WARP. SHR. STR. =	-.150613	WARP. NOR. STR. =	-.459831

COMBINED TORSIONAL INDUCED STRESSES

TOR. SHR. WEB =	-.998990	TOR. SHR. FLANGE =	-1.638695
WARP. SHR. STR. =	-.150613	WARP. NOR. STR. =	-.459831

NORMAL STRESSES (KSI)

POINT	WITHOUT TORSION	TORSION ONLY	COMBINED STRESS
1	.000000	.459831	.459831
3	.000000	-.459831	-.459831
5	.000000	-.459831	-.459831
7	.000000	.459831	.459831

SHEAR STRESSES (KSI)

POINT	WITHOUT TORSION	TORSION ONLY	COMBINED STRESS
2L	.000000	-1.789308	-1.789308
2R	.000000	-1.789308	-1.789308
4L	.000000	.998990	.998990
4R	.000000	-.998990	-.998990
6L	.000000	1.789308	1.789308
6R	.000000	1.789308	1.789308

POINT LOCATIONS OF COMPUTED STRESSES

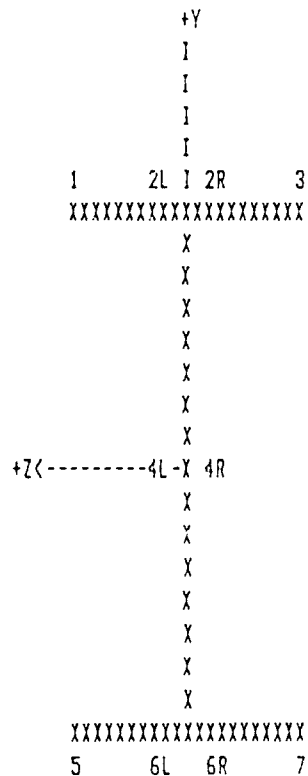

DISTANCE FROM LEFT END OF MEMBER TO SECTION UNDER EXAMINATION IS 108.0000

SFY =	.0000	SFZ =	.0000
SHY2 =	.0000	SHY4 =	.0000
SHZ2 =	.0000		
BHY =	.0000	BMZ =	.0000
BSY1 =	.0000	BSZ1 =	.0000
AXSTR =	.0000		

UNIFORMLY DISTRIBUTED TORSIONAL MOMENT = -.20000000 ENDING AT 108.00000 FROM LEFT END

PHI= -.12769E-01 PHI1= -.81654E-04 PHI2= -.14733E-09 PHI3= -.11071E-06

TOR. SHR. WEB =	-.521281	TOR. SHR. FLANGE =	-.855084
WARP. SHR. STR. =	.110952	WARP. NDR. STR. =	-.000071

COMBINED TORSIONAL INDUCED STRESSES

TOR. SHR. WEB =	-.521281	TOR. SHR. FLANGE =	-.855084
WARP. SHR. STR. =	.110952	WARP. NDR. STR. =	-.000071

"TORSION" PROGRAM INPUT FILE

Problem: 10
Beam Selected: C12x30
End Conditions: Fixed-Free

'CHANNELS' 'C12x30'
8.82 0.51 0.501
12.0 3.17 0.674
5.14 2.06 7.63
162.0 27.0
0.865 29000.0 11200.0
108.0
3
0.0 32.4 108.0
0.0 0.0 0.0
5.4 0.0 0.0
'FIX-FRE'
0
0.0 0.0 0.0 0.0 0.0 0.0 0.0
0.0 0.0 0.0
0.0 0.0 0.0
0.5 32.4
-0.2 108.0
'Y'

INPUT DATA PROBLEM 10 - Part (a)

CHANNEL SECTION C12X30

AREA:	8.8200	THW:	.5100	THF:	.5010		
IY:	5.1400	SY:	2.0600	SYS:	7.6300		
IZ:	162.0000	SZ:	27.0000	Z0:	3.1700		
J:	.8650	CW:	151.2351	WN1:	11.7397	WN3:	5.0201
SW2:	6.0047	SW3:	4.9067	SW4:	-2.4534		
E:	29000.0000	G:	11200.0000				
QY2:	7.1897	QY3:	8.3967	QY4:	16.8261		
QZ2:	1.5606	QZ3:	1.5166				

LENGTH: 108.0000

SECTIONS WHERE STRESSES ARE TO BE CHECKED

.0000
32.4000
108.0000

LEFT END FORCES

FX:	.0000	FY:	.0000	FZ:	.0000
MX:	5.4000	MY:	.0000	MZ:	.0000

UNIFORM LOAD ON MEMBER IN Y-DIR

WY:	.0000	LAY:	.0000	LBY:	.0000
-----	-------	------	-------	------	-------

UNIFORM LOAD ON MEMBER IN Z-DIR

WZ:	.0000	LAZ:	.0000	LBZ:	.0000
-----	-------	------	-------	------	-------

UNIFORMLY DISTRIBUTED TORSIONAL LOAD IS

WX:	.5000	LX:	32.4000
-----	-------	-----	---------

MEMBER END CONDITIONS ARE FIX-FRE

DISTANCE FROM LEFT END OF MEMBER TO SECTION UNDER EXAMINATION IS .0000

SFY =	.0000	SFZ =	.0000
SHY2 =	.0000	SHY3 =	.0000
SHY4 =	.0000		
SHZ2 =	.0000	SHZ3 =	.0000
BY1 =	.0000	BH2 =	.0000
BSY1 =	.0000	BSY3 =	.0000
BSZ1 =	.0000	BSZ3 =	.0000
AXSTR =	.0000		

UNIFORMLY DISTRIBUTED TORSIONAL MOMENT = .50000000 ENDING AT 32.40000 FROM LEFT END

PHI= .00000E+00 PHI1= .00000E+00 PHI2= .38240E-04 PHI3= -.35937E-05

TOR. SHR. WEB =	.000000	TOR. SHR. FLANGE =	.000000		
WARP. SHR. STR. AT 2 =	1.283857	WARP. SHR. STR. AT 3 =	1.049096	WARP. SHR. STR. AT 4	-.515291
WARP. NOR. STR. AT 1 =	13.018810	WARP. NOR. STR. AT 3 =	5.567056		

COMBINED TORSIONAL INDUCED STRESSES

TOR. SHR. WEB =	.000000	TOR. SHR. FLANGE =	.000000		
WARP. SHR. STR. AT 2 =	1.283857	WARP. SHR. STR. AT 3 =	1.049096	WARP. SHR. STR. AT 4	-.515291
WARP. NOR. STR. AT 1 =	13.018810	WARP. NOR. STR. AT 3 =	5.567056		

NORMAL STRESSES (KSI)

POINT.	WITHOUT TORSION	TORSION ONLY	COMBINED STRESS
1	.000000	13.018810	13.018810
3	.000000	-5.567056	-5.567056
5	.000000	5.567056	5.567056
7	.000000	-13.018810	-13.018810

SHEAR STRESSES (KSI)

POINT	WITHOUT TORSION	TORSION ONLY	COMBINED STRESS
2	.000000	1.283857	1.283857
21	.000000	1.283857	1.283857
3	.000000	1.049096	1.049096
31	.000000	1.049096	1.049096
4	.000000	-5.515291	-5.515291
41	.000000	-5.515291	-5.515291
5	.000000	-1.049096	-1.049096
51	.000000	-1.049096	-1.049096
6	.000000	-1.283857	-1.283857
61	.000000	-1.283857	-1.283857

POINT LOCATIONS OF COMPUTED STRESSES

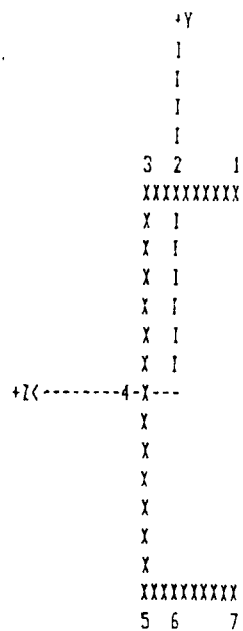

DISTANCE FROM LEFT END OF MEMBER TO SECTION UNDER EXAMINATION IS 32.4000

SFY =	.0000	SFZ =	.0000
SHY2 =	.0000	SHY3 =	.0000
SHY4 =	.0000	SHZ3 =	.0000
SHZ2 =	.0000		
BMX =	.0000	BMZ =	.0000
BSY1 =	.0000	BSY3 =	.0000
BSZ1 =	.0000	BSZ3 =	.0000
AXSTR =	.0000		

UNIFORMLY DISTRIBUTED TORSIONAL MOMENT = .50000000 ENDING AT 32.40000 FROM LEFT END

PHI = .64141E-02 PHI1 = .15835E-03 PHI2 = -.74301E-05 PHI3 = .34976E-06

TOR. SHR. WEB =	.904489	TOR. SHR. FLANGE =	.888528		
WARP. SHR. STR. AT 2 =	-.121577	WARP. SHR. STR. AT 3 =	-.099346	WARP. SHR. STR. AT 4	.048736
WARP. NOR. STR. AT 1 =	-2.529598	WARP. NOR. STR. AT 3 =	-1.081698		

COMBINED TORSIONAL INDUCED STRESSES

TOR. SHR. WEB =	.904489	TOR. SHR. FLANGE =	.888528		
WARP. SHR. STR. AT 2 =	-.121577	WARP. SHR. STR. AT 3 =	-.099346	WARP. SHR. STR. AT 4	.048736
WARP. NOR. STR. AT 1 =	-2.529598	WARP. NOR. STR. AT 3 =	-1.081698		

DISTANCE FROM LEFT END OF MEMBER TO SECTION UNDER EXAMINATION IS 108.0000

SFY =	.0000	SFZ =	.0000
SHY2 =	.0000	SHY3 =	.0000
SHY4 =	.0000	SHZ3 =	.0000
SHZ2 =	.0000		
BNY =	.0000	BNZ =	.0000
BSY1 =	.0000	BSY3 =	.0000
BSZ1 =	.0000	BSZ3 =	.0000
AXSTR =	.0000		

UNIFORMLY DISTRIBUTED TORSIONAL MOMENT = .50000000 ENDING AT 32.40000 FROM LEFT END

PHI = .97777E-02 PHI1 = .90644E-05 PHI2 = -.58488E-10 PHI3 = .20023E-07

TOR. SHR. WEB =	.051776	TOR. SHR. FLANGE =	.050862		
WARP. SHR. STR. AT 2 =	-.006959	WARP. SHR. STR. AT 3 =	-.005687	WARP. SHR. STR. AT 4	.002793
WARP. NOR. STR. AT 1 =	-.000020	WARP. NOR. STR. AT 3 =	-.000009		

COMBINED TORSIONAL INDUCED STRESSES

TOR. SHR. WEB =	.051776	TOR. SHR. FLANGE =	.050862		
WARP. SHR. STR. AT 2 =	-.006959	WARP. SHR. STR. AT 3 =	-.005687	WARP. SHR. STR. AT 4	.002793
WARP. NOR. STR. AT 1 =	-.000020	WARP. NOR. STR. AT 3 =	-.000009		

NORMAL STRESSES (KSI)

POINT	WITHOUT TORSION	TORSION ONLY	COMBINED STRESS
1	.000000	-.000020	-.000020
3	.000000	.000007	.000007
5	.000000	-.000009	-.000009
7	.000000	.000020	.000020

SHEAR STRESSES (KSI)

POINT	WITHOUT TORSION	TORSION ONLY	COMBINED STRESS
2	.000000	.043903	.043903
2I	.000000	-.057822	-.057822
3	.000000	.045175	.045175
3I	.000000	-.056549	-.056549
4	.000000	-.046983	-.046983
4I	.000000	.054569	.054569
5	.000000	-.045175	-.045175
5I	.000000	.056549	.056549
6	.000000	-.043903	-.043903
6I	.000000	.057822	.057822

POINT LOCATIONS OF COMPUTED STRESSES

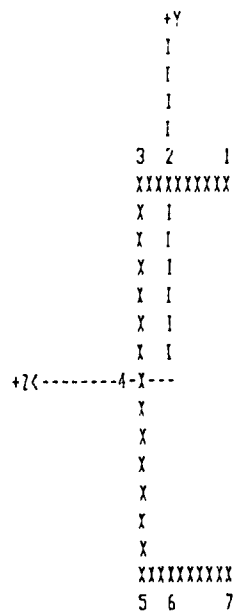

INPUT DATA PROBLEM 10 - Part (b)

CHANNEL SECTION C12X30

AREA:	8.8200	THW:	.5100	THF:	.5010		
IY:	5.1400	SY:	2.0600	SYS:	7.6300		
IZ:	162.0000	SZ:	27.0000	ZD:	3.1700		
J:	.8650	CW:	151.2351	WN1:	11.7397	WN3:	5.0201
SW2:	6.0047	SW3:	.49067	SW4:	-2.4534		
E:	29000.0000	G:	11200.0000				
QY2:	7.1897	QY3:	8.3967	QY4:	16.8261		
QZ2:	1.5606	QZ3:	1.5166				

LENGTH: 108.0000

SECTIONS WHERE STRESSES ARE TO BE CHECKED

.0000
32.4000
108.0000

LEFT END FORCES

FX:	.0000	FY:	.0000	FZ:	.0000
MX:	5.4000	MY:	.0000	MZ:	.0000

UNIFORM LOAD ON MEMBER IN Y-DIR

WY:	.0000	LAY:	.0000	LBY:	.0000
-----	-------	------	-------	------	-------

UNIFORM LOAD ON MEMBER IN Z-DIR

WZ:	.0000	LAZ:	.0000	LBZ:	.0000
-----	-------	------	-------	------	-------

UNIFORMLY DISTRIBUTED TORSIONAL LOAD IS

WX:	-.2000	LX:	108.0000
-----	--------	-----	----------

MEMBER END CONDITIONS ARE FIX-FRE

DISTANCE FROM LEFT END OF MEMBER TO SECTION UNDER EXAMINATION IS .0000

SFY =	.0000	SFZ =	.0000
SHY2 =	.0000	SHY3 =	.0000
SHY4 =	.0000		
SHZ2 =	.0000	SHZ3 =	.0000
BNY =	.0000	BNZ =	.0000
BSY1 =	.0000	BSY3 =	.0000
BSZ1 =	.0000	BSZ3 =	.0000
AXSTR =	.0000		

UNIFORMLY DISTRIBUTED TORSIONAL MOMENT = -.20000000 ENDING AT 108.00000 FROM LEFT END

PHI= .00000E+00 PHI1= .00000E+00 PHI2= -.84394E-04 PHI3= .49250E-05

TOR. SHR. WEB =	.000000	TOR. SHR. FLANGE =	.000000		
WARP. SHR. STR. AT 2 =	-1.711809	WARP. SHR. STR. AT 3 =	-1.398795	WARP. SHR. STR. AT 4	.687055
WARP. NOR. STR. AT 1 =	-28.731930	WARP. NOR. STR. AT 3 =	-12.286250		

COMBINED TORSIONAL INDUCED STRESSES

TOR. SHR. WEB =	.000000	TOR. SHR. FLANGE =	.000000		
WARP. SHR. STR. AT 2 =	-1.711809	WARP. SHR. STR. AT 3 =	-1.398795	WARP. SHR. STR. AT 4	.687055
WARP. NOR. STR. AT 1 =	-28.731930	WARP. NOR. STR. AT 3 =	-12.286250		

NORMAL STRESSES (KSI)

POINT	WITHOUT TORSION	TORSION ONLY	COMBINED STRESS
1	.000000	-28.731930	-28.731930
3	.000000	12.286250	12.286250
5	.000000	-12.286250	-12.286250
7	.000000	28.731930	28.731930

SHEAR STRESSES (KSI)

POINT	WITHOUT TORSION	TORSION ONLY	COMBINED STRESS
2	.000000	-1.711809	-1.711809
2I	.000000	-1.711809	-1.711809
3	.000000	-1.398795	-1.398795
3I	.000000	-1.398795	-1.398795
4	.000000	.687055	.687055
4I	.000000	.687055	.687055
5	.000000	1.398795	1.398795
5I	.000000	1.398795	1.398795
6	.000000	1.711809	1.711809
6I	.000000	1.711809	1.711809

POINT LOCATIONS OF COMPUTED STRESSES

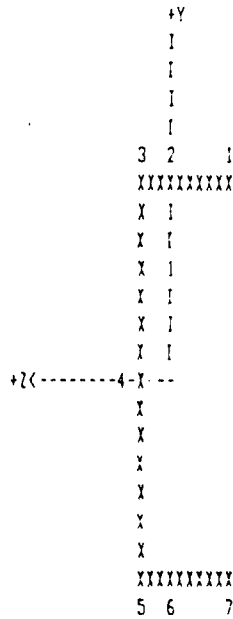

DISTANCE FROM LEFT END OF MEMBER TO SECTION UNDER EXAMINATION IS 32.4000

SFY =	.0000	SFZ =	.0000
SHY2 =	.0000	SHY3 =	.0000
SHY4 =	.0000		
SHZ2 =	.0000	SHZ3 =	.0000
BMX =	.0000	BMZ =	.0000
BSY1 =	.0000	BSY3 =	.0000
BSZ1 =	.0000	BSZ3 =	.0000
AXSTR =	.0000		

UNIFORMLY DISTRIBUTED TORSIONAL MOMENT = -.20000000 ENDING AT 108.00000 FROM LEFT END

PHI = -.24469E-01 PHI1 = -.10860E-02 PHI2 = -.28105E-05 PHI3 = .10485E-05

TOR. SHR. WEB =	-6.203338	TOR. SHR. FLANGE =	-6.093867		
WARP. SHR. STR. AT 2 =	-.364445	WARP. SHR. STR. AT 3 =	-.297804	WARP. SHR. STR. AT 4	.145274
WARP. NOR. STR. AT 1 =	-.956837	WARP. NOR. STR. AT 3 =	-.409159		

COMBINED TORSIONAL INDUCED STRESSES

TOR. SHR. WEB =	-6.203338	TOR. SHR. FLANGE =	-6.093867		
WARP. SHR. STR. AT 2 =	-.364445	WARP. SHR. STR. AT 3 =	-.297804	WARP. SHR. STR. AT 4	.145274
WARP. NOR. STR. AT 1 =	-.956837	WARP. NOR. STR. AT 3 =	-.409159		

NORMAL STRESSES (KSI)

POINT	WITHOUT TORSION	TORSION ONLY	COMBINED STRESS
1	.000000	-.956837	-.956837
3	.000000	.409159	.409159
5	.000000	-.409159	-.409159
7	.000000	.956837	.956837

SHEAR STRESSES (KSI)

POINT	WITHOUT TORSION	TORSION ONLY	COMBINED STRESS
2	.000000	-6.458312	-6.458312
2I	.000000	5.729422	5.729422
3	.000000	-6.391671	-6.391671
3I	.000000	5.796062	5.796062
4	.000000	6.349612	6.349612
4I	.000000	-6.057063	-6.057063
5	.000000	6.391671	6.391671
5I	.000000	-5.796062	-5.796062
6	.000000	6.458312	6.458312
6I	.000000	-5.729422	-5.729422

POINT LOCATIONS OF COMPUTED STRESSES

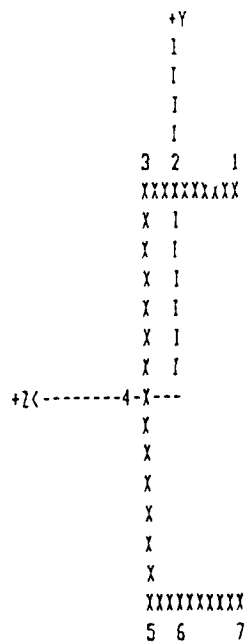

DISTANCE FROM LEFT END OF MEMBER TO SECTION UNDER EXAMINATION IS 108.0000

SFY =	.0000	SFZ =	.0000
SHY2 =	.0000	SHY3 =	.0000
SHY4 =	.0000		
SHZ2 =	.0000	SHZ3 =	.0000
BMV =	.0000	BMZ =	.0000
BSY1 =	.0000	BSY3 =	.0000
BSZ1 =	.0000	BSZ3 =	.0000
AXSTR =	.0000		

UNIFORMLY DISTRIBUTED TORSIONAL MOMENT = -.20000000 ENDING AT 108.00000 FROM LEFT END

PHI= -.82194E-01 PHI1= -.41152E-03 PHI2= -.80697E-08 PHI3= -.90302E-06

TOR. SHR. WEB =	-2.350590	TOR. SHR. FLANGE =	-2.309109		
WARP. SHR. STR. AT 2 =	.315955	WARP. SHR. STR. AT 3 =	.258180	WARP. SHR. STR. AT 4	-.126812
WARP. NOR. STR. AT 1 =	-.002747	WARP. NOR. STR. AT 3 =	-.001175		

COMBINED TORSIONAL INDUCED STRESSES

TOR. SHR. WEB =	-2.350590	TOR. SHR. FLANGE =	-2.309109		
WARP. SHR. STR. AT 2 =	.315955	WARP. SHR. STR. AT 3 =	.258180	WARP. SHR. STR. AT 4	-.126812
WARP. NOR. STR. AT 1 =	-.002747	WARP. NOR. STR. AT 3 =	-.001175		

"TORSION" PROGRAM INPUT FILE

Problem: 11
Beam Selected: C5x9
End Conditions: Fixed-Free

'CHANNELS' 'C5x9'
2.64 0.325 0.320
5.0 1.885 0.478
0.632 0.45 1.322
8.9 3.56
0.109 29000.0 11200.0
42.0
3
0.0 12.6 42.0
0.0 0.0 0.0
-40.0 0.0 0.0
'FIX-FRE'
1
12.6 0.0 0.0 0.0 40.0 0.0 0.0
0.0 0.0 0.0
0.0 0.0 0.0
0.0 0.0
'Y'

INPUT DATA PROBLEM 11

CHANNEL SECTION CSX3

AREA:	2.6400	THW:	.3250	THF:	.3200		
IY:	.6320	SY:	.4500	SYS:	1.3220		
IZ:	8.9000	SZ:	3.5600	ZD:	1.8850		
J:	.1090	CW:	2.9335	WN1:	2.6502	WN3:	1.3604
SW2:	.4802	SW3:	.3499	SW4:	-.1750		
E:	29000.0000	G:	11200.0000				
QY2:	1.0536	QY3:	1.2898	QY4:	2.1796		
QZ2:	.3167	QZ3:	.3008				

LENGTH: 42.0000

SECTIONS WHERE STRESSES ARE TO BE CHECKED

.0000
12.6000
42.0000

LEFT END FORCES

FX:	.0000	FY:	.0000	FZ:	.0000
MX:	-40.0000	MY:	.0000	MZ:	.0000

1 SET OF APPLIED CONCENTRATED LOADS ARE AT 12.60 INCHES FROM LEFT END

FX:	.0000	FY:	.0000	FZ:	.0000
MX:	40.0000	MY:	.0000	MZ:	.0000

UNIFORM LOAD ON MEMBER IN Y-DIR

MY:	.0000	LAY:	.0000	LBV:	.0000
-----	-------	------	-------	------	-------

UNIFORM LOAD ON MEMBER IN Z-DIR

MZ:	.0000	LAZ:	.0000	LBZ:	.0000
-----	-------	------	-------	------	-------

UNIFORMLY DISTRIBUTED TORSIONAL LOAD IS

MX:	.0000	LX:	.0000
-----	-------	-----	-------

MEMBER END CONDITIONS ARE FIX-FRE

DISTANCE FROM LEFT END OF MEMBER TO SECTION UNDER EXAMINATION IS .0000

SFY =	.0000	SFZ =	.0000
SHY2 =	.0000	SHY3 =	.0000
SHY4 =	.0000	SHZ3 =	.0000
SHZ2 =	.0000	BMZ =	.0000
BMZ =	.0000	BSY3 =	.0000
BSY1 =	.0000	BSZ3 =	.0000
BSZ1 =	.0000		
AXSTR =	.0000		

TORSION MOMENT = 40.0000 LOCATION = 12.6000
PHI = .00000E+00 PHI1 = .00000E+00 PHI2 = .30579E-02 PHI3 = -.47020E-03

TOR. SHR. WEB =	.000000	TOR. SHR. FLANGE =	.000000		
WARP. SHR. STR. AT 2 =	20.464080	WARP. SHR. STR. AT 3 =	14.911760	WARP. SHR. STR. AT 4	-7.341170
WARP. NOR. STR. AT 1 =	235.019300	WARP. NOR. STR. AT 3 =	122.418200		

COMBINED TORSIONAL INDUCED STRESSES

TOR. SHR. WEB =	.000000	TOR. SHR. FLANGE =	.000000		
WARP. SHR. STR. AT 2 =	20.464080	WARP. SHR. STR. AT 3 =	14.911760	WARP. SHR. STR. AT 4	-7.341170
WARP. NOR. STR. AT 1 =	235.019300	WARP. NOR. STR. AT 3 =	122.418200		

NORMAL STRESSES (KSI)

POINT	WITHOUT TORSION	TORSION ONLY	COMBINED STRESS
1	.000000	235.019900	235.019900
3	.000000	-122.418200	-122.418200
5	.000000	122.418200	122.418200
7	.000000	-235.019900	-235.019900

SHEAR STRESSES (KSI)

POINT	WITHOUT TORSION	TORSION ONLY	COMBINED STRESS
2	.000000	20.464080	20.464080
2I	.000000	20.464080	20.464080
3	.000000	14.911760	14.911760
3I	.000000	14.911760	14.911760
4	.000000	-7.341170	-7.341170
4I	.000000	-7.341170	-7.341170
5	.000000	-14.911760	-14.911760
5I	.000000	-14.911760	-14.911760
6	.000000	-20.464080	-20.464080
6I	.000000	-20.464080	-20.464080

POINT LOCATIONS OF COMPUTED STRESSES

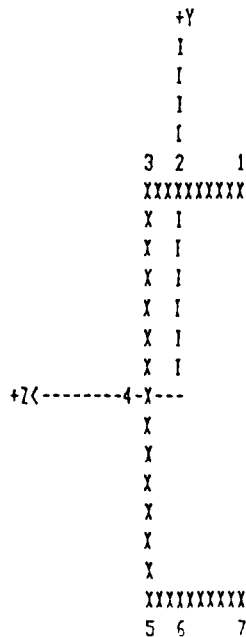

DISTANCE FROM LEFT END OF MEMBER TO SECTION UNDER EXAMINATION IS 12.6000

SFY =	.0000	SFZ =	.0000
SHY2 =	.0000	SHY3 =	.0000
SHY4 =	.0000	SHZ3 =	.0000
SHZ2 =	.0000	BMZ =	.0000
BMZ =	.0000	BSY3 =	.0000
BSY1 =	.0000	BSZ3 =	.0000
BSZ1 =	.0000		
AXSTR =	.0000		

TORSION MOMENT = 40.0000 LOCATION = 12.6000
PHI = .11685E+00 PHI1 = .99488E-02 PHI2 = -.11897E-02 PHI3 = -.32743E-03

TOR. SHR. WEB =	36.213790	TOR. SHR. FLANGE =	35.656660		
WARP. SHR. STR. AT 2 =	14.250400	WARP. SHR. STR. AT 3 =	10.383970	WARP. SHR. STR. AT 4 =	-5.112107
WARP. NOR. STR. AT 1 =	-91.437760	WARP. NOR. STR. AT 3 =	-47.628510		

COMBINED TORSIONAL INDUCED STRESSES

TOR. SHR. WEB =	36.213790	TOR. SHR. FLANGE =	35.656660		
WARP. SHR. STR. AT 2 =	14.250400	WARP. SHR. STR. AT 3 =	10.383970	WARP. SHR. STR. AT 4 =	-5.112107
WARP. NOR. STR. AT 1 =	-91.437760	WARP. NOR. STR. AT 3 =	-47.628510		

NORMAL STRESSES (KSI)

POINT	WITHOUT TORSION	TORSION ONLY	COMBINED STRESS	-----	-----	-----
1	.000000	-91.437760	-91.437760			
3	.000000	47.628510	47.628510			
5	.000000	-47.628510	-47.628510			
7	.000000	91.437760	91.437760			

SHEAR STRESSES (KSI)

POINT	WITHOUT TORSION	TORSION ONLY	COMBINED STRESS	-----	-----	-----
2	.000000	49.907050	49.907050			
2I	.000000	-21.406260	-21.406260			
3	.000000	46.040630	46.040630			
3I	.000000	-25.272690	-25.272690			
4	.000000	-41.325900	-41.325900			
4I	.000000	31.101690	31.101690			
5	.000000	-46.040630	-46.040630			
5I	.000000	25.272690	25.272690			
6	.000000	-49.907050	-49.907050			
6I	.000000	21.406260	21.406260			

POINT LOCATIONS OF COMPUTED STRESSES

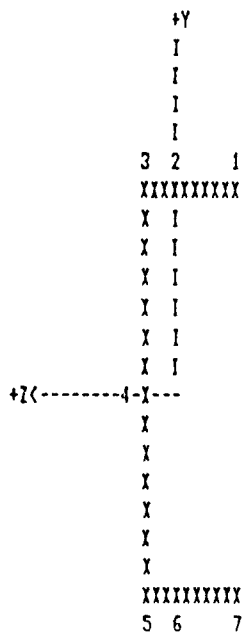

DISTANCE FROM LEFT END OF MEMBER TO SECTION UNDER EXAMINATION IS 42.0000

SFY =	.0000	SFZ =	.0000
SHY2 =	.0000	SHY3 =	.0000
SHY4 =	.0000	SHZ3 =	.0000
SHZ2 =	.0000	BMZ =	.0000
BMY =	.0000	BSY3 =	.0000
BSY1 =	.0000	BSZ3 =	.0000
BSZ1 =	.0000		
AXSTR =	.0000		

TORSION MOMENT = 40.0000 LOCATION = 12.6000
PHI = .19976E+00 PHI1 = .58739E-03 PHI2 = .18900E-08 PHI3 = .84293E-05

TOR. SHR. WEB =	2.138084	TOR. SHR. FLANGE =	2.105191		
WARP. SHR. STR. AT 2 =	-.366860	WARP. SHR. STR. AT 3 =	-.267323	WARP. SHR. STR. AT 4	.131505
WARP. NDR. STR. AT 1 =	.000145	WARP. NDR. STR. AT 3 =	.000076		

COMBINED TORSIONAL INDUCED STRESSES

TOR. SHR. WEB =	2.138084	TOR. SHR. FLANGE =	2.105191		
WARP. SHR. STR. AT 2 =	-.366860	WARP. SHR. STR. AT 3 =	-.267323	WARP. SHR. STR. AT 4	.131505
WARP. NDR. STR. AT 1 =	.000145	WARP. NDR. STR. AT 3 =	.000076		

NORMAL STRESSES (KSI)

POINT	WITHOUT TORSION	TORSION ONLY	COMBINED STRESS
1	.000000	.000145	.000145
3	.000000	-.000076	-.000076
5	.000000	.000076	.000076
7	.000000	-.000145	-.000145

SHEAR STRESSES (KSI)

POINT	WITHOUT TORSION	TORSION ONLY	COMBINED STRESS
2	.000000	1.738331	1.738331
2I	.000000	-2.472050	-2.472050
3	.000000	1.837867	1.837867
3I	.000000	-2.372514	-2.372514
4	.000000	-2.006479	-2.006479
4I	.000000	2.269689	2.269689
5	.000000	-1.837867	-1.837867
5I	.000000	2.372514	2.372514
6	.000000	-1.738331	-1.738331
6I	.000000	2.472050	2.472050

POINT LOCATIONS OF COMPUTED STRESSES

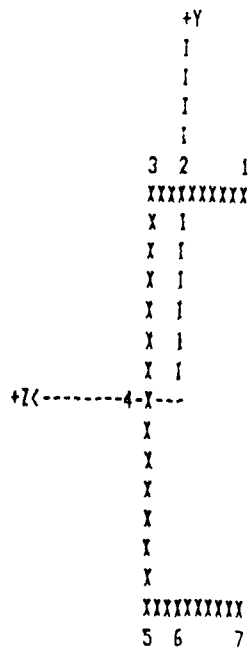

"TORSION" PROGRAM INPUT FILE

Problem: 12
Beam Selected: MC18x42
End Conditions: Fixed-Free

'CHANNELS' 'MC18x42'
12.6 0.45 0.625
18.0 3.95 0.877
14.4 4.69 16.42
554.0 61.6
1.23 29000.0 11200.0
192.0
3
0.0 96.0 192.0
0.0 -2.0 0.0
-38.4 0.0 576.0
'FIX-FRE'
2
96.0 0.0 -2.0 0.0 0.0 0.0 0.0
192.0 0.0 4.0 0.0 0.0 0.0 0.0
0.0 0.0 0.0
0.0 0.0 0.0
0.4 96.0
'Y'

INPUT DATA

PROBLEM 12

CHANNEL SECTION MC18X42

AREA:	12.6000	THW:	.4500	THF:	.6250		
IY:	14.4000	SY:	4.6900	SYS:	16.4200		
IZ:	554.0000	SZ:	61.6000	ZD:	3.9500		
J:	1.2300	CW:	852.2015	WN1:	21.9871	WN3:	10.3739
SN2:	17.3896	SN3:	13.5185	SN4:	-6.7592		
E:	29000.0000	G:	11200.0000				
QY2:	16.6854	QY3:	20.2256	QY4:	37.2069		
QZ2:	2.9510	QZ3:	2.8182				

LENGTH: 192.0000

SECTIONS WHERE STRESSES ARE TO BE CHECKED

.0000
96.0000
192.0000

LEFT END FORCES

FX:	.0000	FY:	-2.0000	FZ:	.0000
MX:	-38.4000	MY:	.0000	MZ:	576.0000

1 SET OF APPLIED CONCENTRATED LOADS ARE AT 96.00 INCHES FROM LEFT END

FX:	.0000	FY:	-2.0000	FZ:	.0000
MX:	.0000	MY:	.0000	MZ:	.0000

2 SET OF APPLIED CONCENTRATED LOADS ARE AT 192.00 INCHES FROM LEFT END

FX:	.0000	FY:	4.0000	FZ:	.0000
MX:	.0000	MY:	.0000	MZ:	.0000

UNIFORM LOAD ON MEMBER IN Y-DIR

MY:	.0000	LAY:	.0000	LBV:	.0000
-----	-------	------	-------	------	-------

UNIFORM LOAD ON MEMBER IN Z-DIR

WZ:	.0000	LAZ:	.0000	LBZ:	.0000
-----	-------	------	-------	------	-------

UNIFORMLY DISTRIBUTED TORSIONAL LOAD IS

WX:	.4000	LX:	96.0000
-----	-------	-----	---------

MEMBER END CONDITIONS ARE FIX-FRE

DISTANCE FROM LEFT END OF MEMBER TO SECTION UNDER EXAMINATION IS .0000

SFY =	2.0000	SFZ =	.0000
SHY2 =	-.0964	SHY3 =	-.1168
SHY4 =	.2985	SHZ3 =	.0000
SHZ2 =	.0000		
BMZ =	.0000	BMZ =	-576.0000
BSY1 =	.0000	BSY3 =	.0000
BSZ1 =	9.3506	BSZ3 =	9.3506
AXSTR =	.0000		

UNIFORMLY DISTRIBUTED TORSIONAL MOMENT = .40000000 ENDING AT 96.00000 FROM LEFT END

PHI = .00000E+00 PHI1 = .00000E+00 PHI2 = .39802E-04 PHI3 = -.15538E-05

TOR. SHR. WEB =	.000000	TOR. SHR. FLANGE =	.000000		
WARP. SHR. STR. AT 2 =	1.253714	WARP. SHR. STR. AT 3 =	.974622	WARP. SHR. STR. AT 4	-.676821
WARP. NOR. STR. AT 1 =	25.378820	WARP. NOR. STR. AT 3 =	11.974170		

COMBINED TORSIONAL INDUCED STRESSES

TOR. SHR. WEB =	.000000	TOR. SHR. FLANGE =	.000000		
WARP. SHR. STR. AT 2 =	1.253714	WARP. SHR. STR. AT 3 =	.974622	WARP. SHR. STR. AT 4	-.676821
WARP. NOR. STR. AT 1 =	25.378820	WARP. NOR. STR. AT 3 =	11.974170		

DISTANCE FROM LEFT END OF MEMBER TO SECTION UNDER EXAMINATION IS 96.0000

SFY =	2.0000	SFZ =	.0000
SHY2 =	-.0964	SHY3 =	-.1168
SHY4 =	.2985	SHZ3 =	.0000
SHZ2 =	.0000	BNZ =	-768.0000
BHY =	.0000	BSY3 =	.0000
BSY1 =	.0000	BSZ3 =	12.4675
BSZ1 =	12.4675		
AXSTR =	.0000		

UNIFORMLY DISTRIBUTED TORSIONAL MOMENT = .40000000 ENDING AT 96.00000 FROM LEFT END

PHI = .49015E-01 PHI1 = .32272E-03 PHI2 = -.74574E-05 PHI3 = .17989E-06

TOR. SHR. WEB =	1.626527	TOR. SHR. FLANGE =	2.259065		
WARP. SHR. STR. AT 2 =	-.145151	WARP. SHR. STR. AT 3 =	-.112839	WARP. SHR. STR. AT 4	.078360
WARP. NOR. STR. AT 1 =	-4.755027	WARP. NOR. STR. AT 3 =	-2.243506		

COMBINED TORSIONAL INDUCED STRESSES

TOR. SHR. WEB =	1.626527	TOR. SHR. FLANGE =	2.259065		
WARP. SHR. STR. AT 2 =	-.145151	WARP. SHR. STR. AT 3 =	-.112839	WARP. SHR. STR. AT 4	.078360
WARP. NOR. STR. AT 1 =	-4.755027	WARP. NOR. STR. AT 3 =	-2.243506		

NORMAL STRESSES (KSI)

POINT	WITHOUT TORSION	TORSION ONLY	COMBINED STRESS
1	12.467530	-4.755027	7.712506
3	12.467530	2.243506	14.711040
5	-12.467530	-2.243506	-14.711040
7	-12.467530	4.755027	-7.712506

SHEAR STRESSES (KSI)

POINT	WITHOUT TORSION	TORSION ONLY	COMBINED STRESS
2	-.096378	2.113914	2.017536
2I	-.096378	-2.404217	-2.500594
3	-.116826	2.146226	2.029400
3I	-.116826	-2.371904	-2.488731
4	.298491	-1.548167	-1.249675
4I	.298491	1.704887	2.003378
5	.116826	-2.146226	-2.029400
5I	.116826	2.371904	2.488731
6	.096378	-2.113914	-2.017536
6I	.096378	2.404217	2.500594

POINT LOCATIONS OF COMPUTED STRESSES

```

      +Y
      I
      I
      I
      I
      I
      I
      3 2 1
      XXXXXXXXXXXX
      X I
      X I
      X I
      X I
      X I
      X I
      X I
      X I
      X I
      X I
      +Z-----4-X---
      X
      X
      X
      X
      X
      X
      XXXXXXXXXXXX
      5 6 7
  
```

DISTANCE FROM LEFT END OF MEMBER TO SECTION UNDER EXAMINATION IS 192.0000

SFY =	4.0000	SFZ =	.0000
SHY2 =	-.1928	SHY3 =	-.2337
SHY4 =	.5970	SH23 =	.0000
SHZ2 =	.0000		
BMY =	.0000	BHZ =	-1152.0000
BSY1 =	.0000	BSY3 =	.0000
BSZ1 =	18.7013	BSZ3 =	18.7013
AXSTR =	.0000		

UNIFORMLY DISTRIBUTED TORSIONAL MOMENT = .40000000 ENDING AT 96.00000 FROM LEFT END

PHI = .62393E-01 PHI1 = .66205E-04 PHI2 = -.25325E-09 PHI3 = .36904E-07

TOR. SHR. WEB =	.333675	TOR. SHR. FLANGE =	.463438		
WARP. SHR. STR. AT 2 =	-.029777	WARP. SHR. STR. AT 3 =	-.023148	WARP. SHR. STR. AT 4	.016075
WARP. NDR. STR. AT 1 =	-.000161	WARP. NDR. STR. AT 3 =	-.000076		

COMBINED TORSIONAL INDUCED STRESSES

TOR. SHR. WEB =	.333675	TOR. SHR. FLANGE =	.463438		
WARP. SHR. STR. AT 2 =	-.029777	WARP. SHR. STR. AT 3 =	-.023148	WARP. SHR. STR. AT 4	.016075
WARP. NDR. STR. AT 1 =	-.000161	WARP. NDR. STR. AT 3 =	-.000076		

NORMAL STRESSES (KSI)

POINT	WITHOUT TORSION	TORSION ONLY	COMBINED STRESS
1	18.701300	-.000161	18.701140
3	18.701300	.000076	18.701380
5	-18.701300	-.000076	-18.701380
7	-18.701300	.000161	-18.701140

SHEAR STRESSES (KSI)

POINT	WITHOUT TORSION	TORSION ONLY	COMBINED STRESS
2	-.192756	.433661	.240905
2I	-.192756	-.493215	-.685971
3	-.233653	.440289	.206636
3I	-.233653	-.486586	-.720239
4	.596982	-.317600	.279383
4I	.596982	.349750	.946733
5	.233653	-.440289	-.206636
5I	.233653	.486586	.720239
6	.192756	-.433661	-.240905
6I	.192756	.493215	.685971

POINT LOCATIONS OF COMPUTED STRESSES

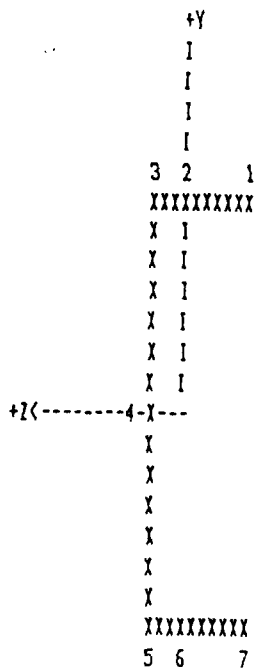

APPENDIX D

GTSTRU DL INPUT/OUTPUT FILE PRINTOUTS

<u>Problem No.</u>	<u>Beam Selected</u>	<u>End Conditions</u>
1	W14x10	Fixed-Free
2	W14x119	Pinned-Fixed
3	W12x75	Pinned-Pinned
4	W14x9	Fixed-Fixed
5	W8x15	Fixed-Free
6	W10x49	Fixed-Free
7	W6x15	Fixed-Free
8	W8x67	Fixed-Free
9	C10x20	Fixed-Free
10	C12x30	Fixed-Free
11	C5x	Fixed-free
12	MC18x	Fixed-Free

"GTSTRUDL" INPUT/OUTPUT FILE PRINTOUT

Problem: 1
Beam Selected: W14x109
End Conditions: Fixed-Free

Analyses taken at 3 Locations:

Location 1: 0 inches
Location 2: 210 inches
Location 3: 300 inches

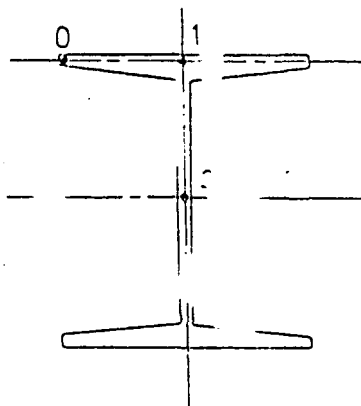
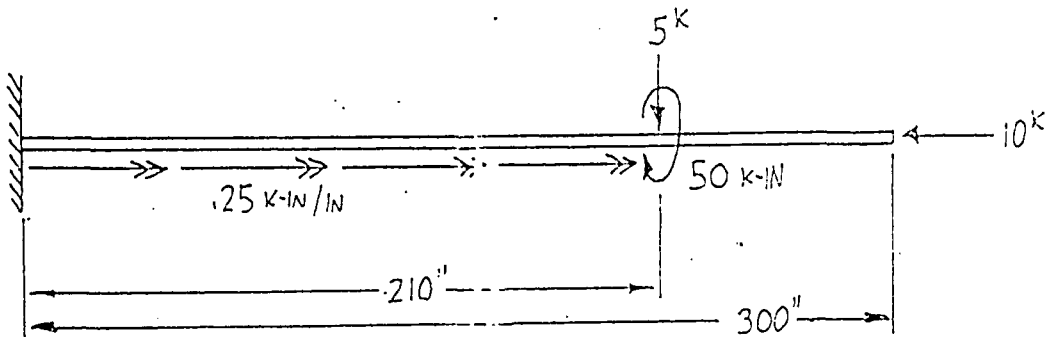

Pt. 0: Flange Tip
Pt. 1: Flange/Web Connection
Pt. 3: Web (at Neutral Axis)

RESTRICTED RIGHTS LEGEND

Use, duplication, or disclosure by the US Government is subject to restrictions as set forth in subparagraph (C) (1) (1) of the Rights in Technical Data and Computer Software clause at DFARS 252.227-7013.

This computer software is an unpublished work containing valuable trade secrets owned by the Georgia Tech Research Corporation (GTRC). No access, use, transfer, duplication or disclosure thereof may be made except under a license agreement executed by GTRC or its authorized representatives and no right, title or interest thereto is conveyed or granted herein notwithstanding receipt or possession hereof. Decompilation of the object code is strictly prohibited.

Georgia Tech Research Corporation
 Georgia Institute of Technology
 Atlanta, Georgia 30332 U.S.A.

Copyright (c) GTRC
 ALL RIGHTS RESERVED.

/SYS_SAVE*CTI_STRUCL:CTIST9101.CDB/IF_1=USERDAT_DS/IF_2*CTI_STRUCL:CTIST9101.DS/NOODUMP/IF_3=BYTEMP.TMP/TEMPORARY/IF_4*CTI_STRUCL:ML
 T_DS/POOL_INCR=18384/IF_7=PLOYFIL_DS/WRITE/HOLE_OF=4
 SYAUBL''W14X108''FIXED-FREE

*** G T S T R U D L ***

RELEASE DATE	VERSION	MOD LEVEL	COMPLETION NO.
DECEMBER 1991	8101VAX		2831

ACTIVE UNITS	LENGTH	WEIGHT	ANGLE	TEMPERATURE	TIME
ASSUMED TO BE	INCH	POUND	RADIAN	FAHRENHEIT	SECOND

UNITS KIPS INCHES
 JOINT COORDINATES
 *1 0 0 0 SUPPORT
 *1 300 0 0 FREE
 TYPE SPACE FRAME
 MEMBER INCIDENCES
 1 *A *B

CONSTRNYS
 B 28000
 C 11200

MEMBER PROPERTIES TABLE 'STEELW78'

1 TABLE 'STEELW78' 'W14X108'

LOADING 1

MEMBER LOAD

1 FORCE Y GLOBAL CONC P -5 L 210

MEMBER LOAD

1 MOMENT X GLOBAL UNIFORM W .25 LA 0 LB 210

MEMBER LOAD

1 MOMENT X GLOBAL CONC 50 L 210

STIFFNESS ANALYSIS

TIME FOR CONSISTENCY CHECKS FOR 1 MEMBERS 0.14 SECONDS

TIME FOR BANDWIDTH REDUCTION 0.00 SECONDS

TIME TO GENERATE 1 ELEMENT STIF. MATRICES 0.07 SECONDS

TIME TO PROCESS 3 MEMBER LOADS 0.12 SECONDS

TIME TO ASSEMBLE THE STIFFNESS MATRIX 0.04 SECONDS

TIME TO PROCESS 2 JOINTS 0.01 SECONDS

TIME TO SOLVE WITH 1 PARTITIONS 0.03 SECONDS

TIME TO PROCESS 2 JOINT DISPLACEMENTS 0.00 SECONDS

TIME TO PROCESS 1 ELEMENT DISTORTIONS 0.01 SECONDS

TIME FOR STATICS CHECK 0.01 SECONDS

OUTPUT BY MEMBER

LIST SECTION STRESSES POSITION ALL MEMBER 1 SECTION NS 3 0 210 300

 RESULTS OF LATEST ANALYSES

PROBLEM - W14X108 TITLE - FIXED-FREE

ACTIVE UNITS INCH KIP RAD DEG SEC

INTERNAL MEMBER RESULTS

MEMBER SECTION STRESS

DISTANCE FROM START	POSITION	STRESS					
		AXIAL	X SHEAR	Y BENDING	Z BENDING	COMBINED NORMAL	

MEMBER 1

LOADING 1

LOADING	MEMBER	SECTION	AXIAL	X SHEAR	Y BENDING	Z BENDING	COMBINED NORMAL
0.000	1	1	0.000000E+00	0.000000E+00	0.000000E+00	0.000000E+00	0.000000E+00
		2	0.000000E+00	-0.334989E	-0.198187	0.000000E+00	0.000000E+00
		3	0.000000E+00	0.000000E+00	0.000000E+00	0.000000E+00	0.000000E+00
		4	0.000000E+00	0.000000E+00	0.000000E+00	0.000000E+00	-0.000000E+00
		5	0.000000E+00	-0.334989E	-0.198187	0.000000E+00	-0.000000E+00
		6	0.000000E+00	0.000000E+00	0.000000E+00	0.000000E+00	-0.000000E+00
		7	0.000000E+00	0.129252E	0.000000E+00	0.000000E+00	0.000000E+00
210.000	1	1	0.000000E+00	0.000000E+00	0.000000E+00	0.000000E+00	0.000000E+00
		2	0.000000E+00	-0.334989E	-0.198187	0.000000E+00	0.000000E+00
		3	0.000000E+00	0.000000E+00	0.000000E+00	0.000000E+00	0.000000E+00
		4	0.000000E+00	0.000000E+00	0.000000E+00	0.000000E+00	0.000000E+00

300.000

1	0.000000E+00	0.000000E+00	0.000000E+00	0.000000E+00	0.000000E+00	0.000000E+00
2	0.000000E+00	0.000000E+00	0.000000E+00	0.000000E+00	0.000000E+00	0.000000E+00
3	0.000000E+00	0.000000E+00	0.000000E+00	0.000000E+00	0.000000E+00	0.000000E+00
4	0.000000E+00	0.000000E+00	0.000000E+00	0.000000E+00	0.000000E+00	0.000000E+00
5	0.000000E+00	0.000000E+00	0.000000E+00	0.000000E+00	0.000000E+00	0.000000E+00
6	0.000000E+00	0.000000E+00	0.000000E+00	0.000000E+00	0.000000E+00	0.000000E+00
7	0.000000E+00	0.000000E+00	0.000000E+00	0.000000E+00	0.000000E+00	0.000000E+00

WYISH

"GTSTRU DL" INPUT/OUTPUT FILE PRINTOUT

Problem: 2
Beam Selected: W14x159
End Conditions: Pinned-Fixed

Analyses take: at 3 Locations:

Location 1: 0 inches
Location 2: 108 inches
Location 3: 432 inches

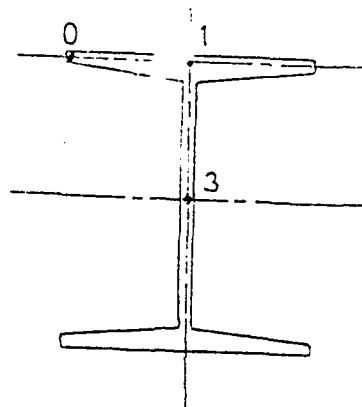
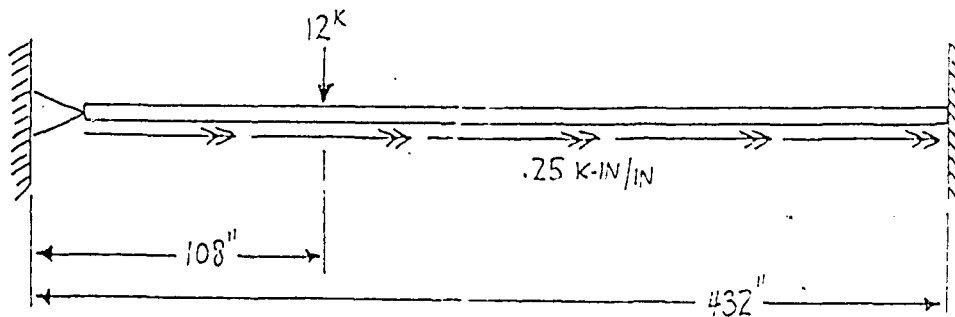

Pt. 0: Flange Tip
Pt. 1: Flange/Web Connection
Pt. 3: Web (at Neutral Axis)

432.000

1	0.0000000E+00	0.0000000E+00	0.0000000E+00	0.0000000E+00	2.374903	2.374903
2	0.0000000E+00	0.0000000E+00	0.1241631	0.0000000E+00	2.374903	2.374903
3	0.0000000E+00	0.0000000E+00	0.0000000E+00	0.0000000E+00	2.374903	2.374903
4	0.0000000E+00	0.0000000E+00	0.0000000E+00	0.0000000E+00	-2.374903	-2.374903
5	0.0000000E+00	0.2068843	0.1241631	0.0000000E+00	-2.374903	-2.374903
6	0.0000000E+00	0.0000000E+00	0.0000000E+00	0.0000000E+00	-2.374903	-2.374903
7	0.0000000E+00	0.4425741	0.0000000E+00	0.0000000E+00	0.0000000E+00	0.0000000E+00

PTWISH

"GTSTRUDL" INPUT/OUTPUT FILE PRINTOUT

Problem: 3
Beam Selected: W12x79
End Conditions: Pinned-Pinned

Analyses taken at 4 Locations:

Location 1: 0 inches
Location 2: 36 inches
Location 3: 252 inches
Location 4: 360 inches

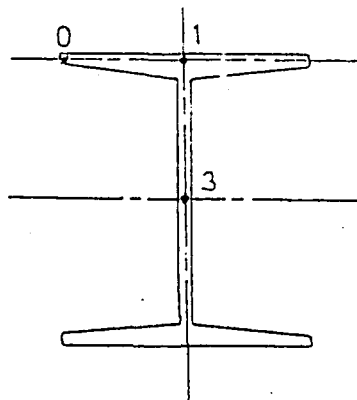
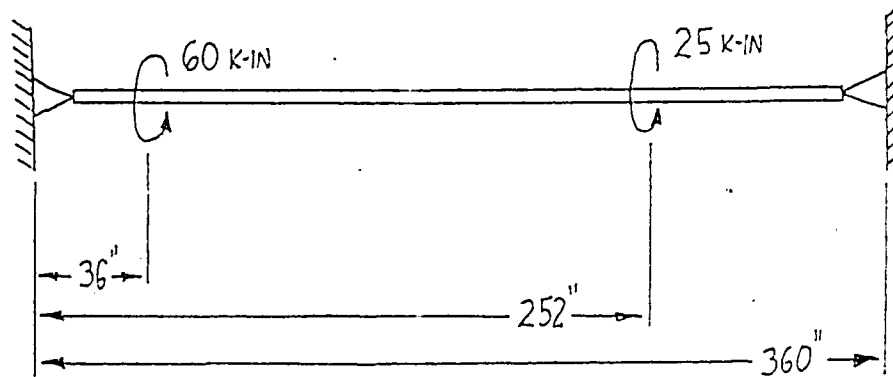

Pt. 0: Flange Tip
Pt. 1: Flange/Web Connection
Pt. 3: Web (at Neutral Axis)

"GTSTRUDL" INPUT/OUTPUT FILE PRINTOUT

Problem: 4
Beam Selected: W14x90
End Conditions: Fixed-Fixed

Analyses taken at 3 Locations:

Location 1: 0 inches
Location 2: 240 inches
Location 3: 480 inches

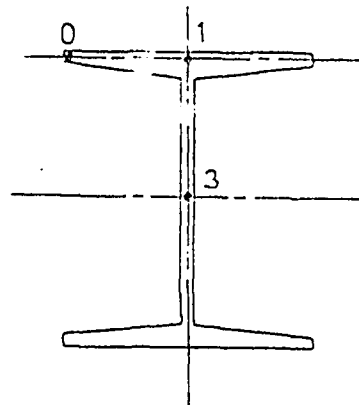
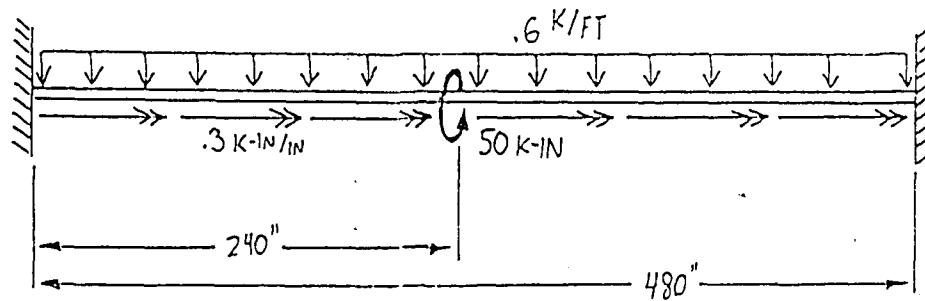

Pt. 0: Flange Tip
Pt. 1: Flange/Web Connection
Pt. 3: Web (at Neutral Axis)

RESTRICTED RIGHTS LEGEND

Use, duplication, or disclosure by the US Government is subject to restrictions as set forth in subparagraph (C) (1) (ii) of the Rights in Technical Data and Computer Software clause at DFARS 252.227-7013.

This computer software is an unpublished work containing valuable trade secrets owned by the Georgia Tech Research Corporation (GTRC). No access, use, transfer, duplication or disclosure thereof may be made except under a license agreement executed by GTRC or its authorized representatives and no right, title or interest thereto is conveyed or granted herein notwithstanding receipt or possession hereof. Decompilation of the object code is strictly prohibited.

Georgia Tech Research Corporation
Georgia Institute of Technology
Atlanta, Georgia 30332 U.S.A.

Copyright (c) GTRC
ALL RIGHTS RESERVED.

/SYS SAVE CT1 STRUCL:CTIST9101.CDB/IF 1 USERDAT.DS/IF 2 CT1 STRUCL:CTIST9101.DS/NO DUMP/IF 3 DYTEMP.TMP/TEMPORARY/IF 4 CT1 STRUCL:KE1
I.DS/POOL INCR=10384/IF 7 PLOT/PIL.DS/WRITE/HOLE 01-4
STRUCL W14X90 FIXED-FIXED

*** G Y S T R U D L ***

Table with columns: RELEASE DATE, VERSION, MOD LEVEL, COMPLETION NO.
DECEMBER 1981, SIGTIVAX, 1, 2031

**** ACTIVE UNITS - LENGTH WEIGHT ANGLE TEMPERATURE TIME
**** ASSUMED TO BE INCH POUND RADIAN FAHRENHEIT SECOND

UNITS KIPS INCHES
JOINT COORDINATES
'A' 0 0 0 SUPPORT
'B' 480 0 0 SUPPORT
TYPE SPACE FRAME
MEMBER INCIDENCES
1 'A' 'B'
CONSYNANS
E 29000
G 11200

MEMBER PROPERTIES TABLE 'STEEL78'

TABLE 'STEEL78' W14X90

LOADING 1

MEMBER LOAD

1 FORCE Y GLOBAL UNIFORM W - .05 LA 0 LB 480

MEMBER LOAD

1 MOMENT X GLOBAL CONC SO L 240

MEMBER LOAD

1 MOMENT X GLOBAL UNIFORM W .3 LA 0 LB 480

STIFFNESS ANALYSIS

TIME FOR CONSISTENCY CHECKS FOR 1 MEMBERS 0.18 SECONDS

TIME FOR BANDWIDTH REDUCTION 0.00 SECONDS

TIME TO GENERATE 1 ELEMENT STIF. MATRICES 0.10 SECONDS

TIME TO PROCESS 3 MEMBER LOADS 0.14 SECONDS

TIME TO PROCESS 2 JOINTS 0.00 SECONDS

TIME TO PROCESS 2 JOINT DISPLACEMENTS 0.00 SECONDS

TIME TO PROCESS 1 ELEMENT DISTORTIONS 0.01 SECONDS

TIME FOR STATICS CHECK 0.00 SECONDS

OUTPUT BY MEMBER

LIST SECTION STRESSES POSITION ALL MEMBER 1 SECTION NS 3 0 240 480

RESULTS OF LATEST ANALYSES

PROBLEM - W14X90 TITLE - FIXED-FIXED

ACTIVE UNITS INCH KIP RAD DECF SEC

INTERNAL MEMBER RESULTS

MEMBER SECTION STRESS

Table header: DISTANCE FROM START, POSITION, AXIAL, Y SHEAR, Z SHEAR, STRESS (Y BENDING, Z BENDING, COMBINED NORMAL)

MEMBER 1

LOADING 1

Main data table showing stress results for member 1 under loading 1. Columns include distance from start, position, axial, shear, and bending stresses.

2	0.000000E+00	0.9614744	0.5803640	0.000000E+00	6.713287	6.713287
3	0.000000E+00	0.000000E+00	0.000000E+00	0.000000E+00	6.713287	6.713287
4	0.000000E+00	0.000000E+00	0.000000E+00	0.000000E+00	-6.713287	-6.713287
5	0.000000E+00	0.9614744	0.5803640	0.000000E+00	-6.713287	-6.713287
6	0.000000E+00	0.000000E+00	0.000000E+00	0.000000E+00	-6.713287	-6.713287
7	0.000000E+00	2.11332	0.000000E+00	0.000000E+00	0.000000E+00	0.000000E+00

FINISH

"GTSTRUDL" INPUT/OUTPUT FILE PRINTOUT

Problem: 5
Beam Selected: W8x15
End Conditions: Fixed-Free

Analyses taken at 3 Locations:

Location 1: 0 inches
Location 2: 18 inches
Location 3: 60 inches

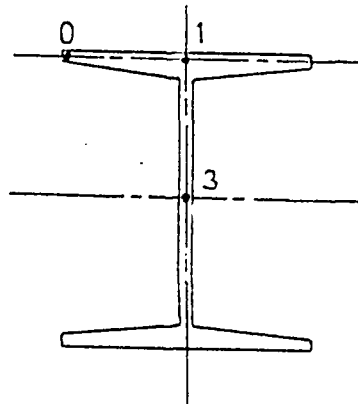
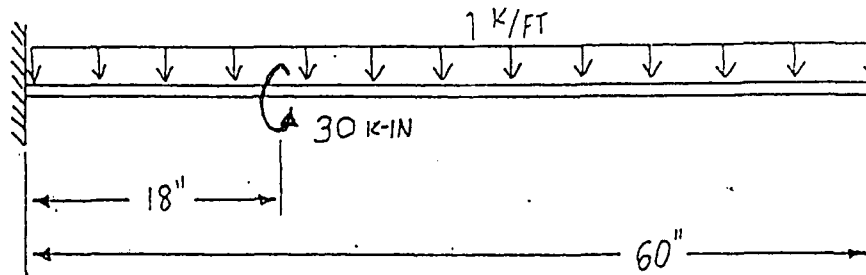

Pt. 0: Flange Tip
Pt. 1: Flange/Web Connection
Pt. 3: Web (at Neutral Axis)

RESTRICTED RIGHTS LEGEND

Use, duplication, or disclosure by the US Government is subject to restrictions as set forth in subparagraph (C) (1) (iii) of the Rights in Technical Data and Computer Software clause at DFARS 252.227-7013.

This computer software is an unpublished work containing valuable trade secrets owned by the Georgia Tech Research Corporation (GTRC). No access, use, transfer, duplication or disclosure thereof may be made except under a license agreement executed by GTRC or its authorized representatives and no right, title or interest thereto is conveyed or granted herein notwithstanding receipt or possession hereof. Decompilation of the object code is strictly prohibited.

Georgia Tech Research Corporation
Georgia Institute of Technology
Atlanta, Georgia 30332 U.S.A.

Copyright (c) GTRC
ALL RIGHTS RESERVED.

/SYS_SAVE=GTI_STRAUL;GTIST9101.CDB/IF_1=USERDAT.DS/IF_2=GTI_STRAUL;GTIST9101.DS/NO DUMP/IF_3=DTYEMP.TMP/TEMPORARY/IF_4=GTI_STRAUL;MEL
T.DS/POOL INCR=16384/IF_7=P:DTFIL.DS/WRITE/MOLL 0**4
STRAUL=WBXIS*FIXED*FREE

*** G T S T R U D L ***

RELEASE DATE	VERSION	MOD LEVEL	COMPLETION NO.
DECEMBER 1981	9101VAX	1	2831

**** ACTIVE UNITS - LENGTH WEIGHT ANGLE TEMPERATURE TIME
**** ASSUMED TO BE INCH POUND RADIAN FAHRENHEIT SECOND

UNITS KIPS INCHES
JOINT COORDINATES
A 0 0 0 SUPPORT

B 60 0 0 FREE
TYPE SPACE FRAME
MEMBER INCIDENCES
1 *A* *B*

CONSTANTS
E 29000
G 11700

MEMBER PROPERTIES TABLE *STEELW*

1 TABLE *STEELW* *WBXIS*

LOADING 1

MEMBER LOAD

1 MOMENT 2 GLOBAL CONC 30 L 18

MEMBER LOAD

1 FORCE Y GLOBAL UNIFORM W -.08333 LA 0 LB 60

STIFFNESS ANALYSIS

TIME FOR CONSISTENCY CHECKS FOR 1 MEMBERS 0.16 SECONDS

TIME FOR BANDWIDTH REDUCTION 0.00 SECONDS

TIME TO GENERATE 1 ELEMENT STIF. MATRICES 0.05 SECONDS

TIME TO PROCESS 2 MEMBER LOADS 0.17 SECONDS

TIME TO ASSEMBLE THE STIFFNESS MATRIX 0.02 SECONDS

TIME TO PROCESS 2 JOINTS 0.00 SECONDS

TIME TO SOLVE WITH 1 PARTITIONS 0.02 SECONDS

TIME TO PROCESS 2 JOINT DISPLACEMENTS 0.00 SECONDS

TIME TO PROCESS 1 ELEMENT DISTORTIONS 0.02 SECONDS

TIME FOR STATICS CHECK 0.00 SECONDS

OUTPUT BY MEMBER

LIST SECTION STRESSES POSITION ALL MEMBER 1 SECTION NS 3 0 18 60

RESULTS OF LATEST ANALYSES

PROBLEM - WBXIS TITLE - FIXED-FREE

ACTIVE UNITS INCH KIP RAD DEGF SEC

INTERNAL MEMBER RESULTS

MEMBER SECTION STRESS

DISTANCE FROM START	POSITION	AXIAL	Y SHEAR	Z SHEAR	STRESS Y BENDING	Z BENDING	COMBINED NORMAL
---------------------	----------	-------	---------	---------	------------------	-----------	-----------------

MEMBER 1

LOADING 1

0.000	1	0.000000E+00	0.000000E+00	0.000000E+00	0.000000E+00	12.71136	12.71136
	2	0.000000E+00	-1.054813	-0.814444	0.000000E+00	12.71136	12.71136
	3	0.000000E+00	0.000000E+00	0.000000E+00	0.000000E+00	12.71136	12.71136
	4	0.000000E+00	0.000000E+00	0.000000E+00	0.000000E+00	-12.71136	-12.71136
	5	0.000000E+00	-1.054813	-0.814444	0.000000E+00	-12.71136	-12.71136
	6	0.000000E+00	0.000000E+00	0.000000E+00	0.000000E+00	-12.71136	-12.71136
	7	0.000000E+00	-2.818950	0.000000E+00	0.000000E+00	0.000000E+00	0.000000E+00
18.000	1	0.000000E+00	0.000000E+00	0.000000E+00	0.000000E+00	6.228563	6.228563
	2	0.000000E+00	-0.7453692	-0.5701113	0.000000E+00	6.228563	6.228563
	3	0.000000E+00	0.000000E+00	0.000000E+00	0.000000E+00	6.228563	6.228563
	4	0.000000E+00	0.000000E+00	0.000000E+00	0.000000E+00	-6.228563	-6.228563
	5	0.000000E+00	-0.7453692	-0.5701113	0.000000E+00	-6.228563	-6.228563
	6	0.000000E+00	0.000000E+00	0.000000E+00	0.000000E+00	-6.228563	-6.228563

80.000

1	0.000000E+00	0.000000E+00	0.000000E+00	0.000000E+00	0.000000E+00	-0.1215531E-05	-0.1215531E-05
2	0.000000E+00	-0.3249682E-07	-0.248558E-07	0.000000E+00	0.000000E+00	-0.1215531E-05	-0.1215531E-05
3	0.000000E+00	0.000000E+00	0.000000E+00	0.000000E+00	0.000000E+00	-0.1215531E-05	-0.1215531E-05
4	0.000000E+00	0.000000E+00	0.000000E+00	0.000000E+00	0.000000E+00	0.1215531E-05	0.1215531E-05
5	0.000000E+00	-0.3249682E-07	-0.248558E-07	0.000000E+00	0.000000E+00	0.1215531E-05	0.1215531E-05
6	0.000000E+00	0.000000E+00	0.000000E+00	0.000000E+00	0.000000E+00	-0.1215531E-05	-0.1215531E-05
7	0.000000E+00	-0.8556332E-07	0.000000E+00	0.000000E+00	0.000000E+00	0.000000E+00	0.000000E+00

FINISH

"GTSTRUDL" INPUT/OUTPUT FILE PRINTOUT

Problem: 6
Beam Selected: W10x49
End Conditions: Fixed-Free

Analyses taken at 3 Locations:

Location 1: 0 inches
Location 2: 96 inches
Location 3: 192 inches

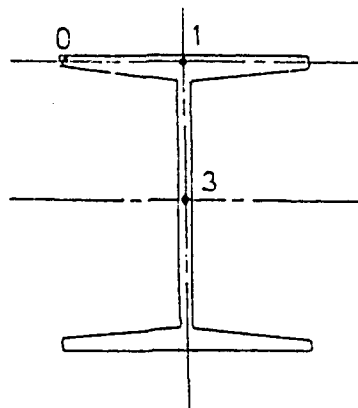
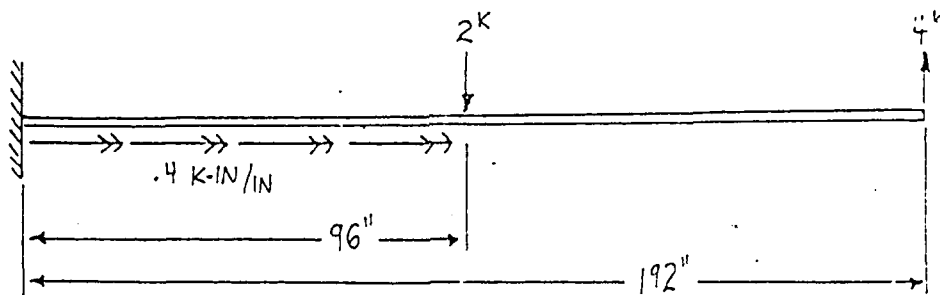

Pt. 0: Flange Tip
Pt. 1: Flange/Web Connection
Pt. 3: Web (at Neutral Axis)

RESTRICTED RIGHTS LEGEND

Use, duplication, or disclosure by the US Government is subject to restrictions as set forth in subparagraph (C) (1) (ii) of the Rights in Technical Data and Computer Software clause at DFARS 252.227-7013.

This computer software is an unpublished work containing valuable trade secrets owned by the Georgia Tech Research Corporation (GTRC). No access, use, transfer, duplication or disclosure thereof may be made except under a license agreement executed by GTRC or its authorized representatives and no right, title or interest therein is conveyed or granted herein notwithstanding receipt or possession hereof. Decompilation of the object code is strictly prohibited.

Georgia Tech Research Corporation
Georgia Institute of Technology
Atlanta, Georgia 30332 U.S.A.

Copyright (c) GTRC
All Rights Reserved.

/SVS_SAVE:CTI_STRUDL:CTIST9101.CDB/IF_1:USERDAT.DS/IF_2:CTI_STRUDL:CTIST9101.DS/HODUMP/IF_3:DYTEMP.TMP/TEMPORARY/IF_4:CTI_STRUDL:HEL
T.DS/POOL_INCR:18384/IF_7:PLOTFIL.DS/WRITE/HOLE_0:4
SYA00L W10X49 FIXED-FREE

*** G T S T A U D L ***
RELEASE DATE DECEMBER 1991

VERSION 9101VAX MOD LEVEL 1 COMPLETION NO. 2431

**** ACTIVE UNITS - LENGTH WEIGHT ANGLE TEMPERATURE TIME
**** ASSUMED TO BE INCH POUND Radian Fahrenheit SECOND

UNITS KIPS INCHES
JOINT COORDINATES
'A' 0 0 0 SUPPORT
'B' 182 0 0 FREE
TYPE SPACE FRAME
MEMBER INCIDENCES
1 'A' 'B'
CONSISTENCY
E 29000
G 11200

MEMBER PROPERTIES TABLE 'STEELW'
1 TABLE 'STEELW' W10X49
LOADING 1
MEMBER LOAD
1 FORCE Y GLOBAL CONC P 2 L 96
MEMBER LOAD
1 FORCE Y GLOBAL CONC P 4 L 192
MEMBER LOAD
1 MOMENT X GLOBAL UNIFORM W 5 LA 0 LB 96

STIFFNESS ANALYSIS
TIME FOR CONSISTENCY CHECKS FOR 1 MEMBERS 0.15 SECONDS
TIME FOR BANDWIDTH REDUCTION 0.00 SECONDS
TIME TO GENERATE 1 ELEMENT STIF MATRICES 0.07 SECONDS
TIME TO PROCESS 3 MEMBER LOADS 0.17 SECONDS
TIME TO ASSEMBLE THE STIFFNESS MATRIX 0.05 SECONDS
TIME TO PROCESS 2 JOINTS 0.01 SECONDS
TIME TO SOLVE WITH 1 PARTITIONS 0.03 SECONDS
TIME TO PROCESS 1 JOINT DISPLACEMENTS 0.00 SECONDS
TIME TO PROCESS 1 ELEMENT DISTORTIONS 0.01 SECONDS
TIME FOR STATICS CHECK 0.02 SECONDS
OUTPUT BY MEMBER

LIST SECTION STRESSES POSITION ALL MEMBER 1 SECTION NS 3 0 96 192

RESULTS OF LATEST ANALYSIS

PROBLEM - W10X49 TITLE - FIXED-FREE

ACTIVE UNITS INCH KIP RAD DEG/SEC

INTERNAL MEMBER RESULTS

MEMBER SECTION STRESS

DISTANCE / STRESS /
FROM SYMB POSITION AXIAL V SHEAR X SHEAR Y BENDING Z BENDING COMBINED NORMAL

MEMBER 1

LOADING 1

LOADING	MEMBER	SECTION	AXIAL	V SHEAR	X SHEAR	Y BENDING	Z BENDING	COMBINED NORMAL
0.000	1	1	0.000000E+00	0.000000E+00	0.000000E+00	0.000000E+00	-10.54945	-10.54945
		2	0.000000E+00	0.292185E	0.172970E	0.000000E+00	-10.54945	-10.54945
		3	0.000000E+00	0.000000E+00	0.000000E+00	0.000000E+00	-10.54945	-10.54945
		4	0.000000E+00	0.000000E+00	0.000000E+00	0.000000E+00	10.54945	10.54945
		5	0.000000E+00	0.292185E	0.172970E	0.000000E+00	10.54945	10.54945
		6	0.000000E+00	0.000000E+00	0.000000E+00	0.000000E+00	10.54945	10.54945
		7	0.000000E+00	0.139894E	0.000000E+00	0.000000E+00	0.000000E+00	0.000000E+00
96.000	1	1	0.000000E+00	0.000000E+00	0.000000E+00	0.000000E+00	-7.03296E	-7.03296E
		2	0.000000E+00	0.292195E	0.172970E	0.000000E+00	-7.03296E	-7.03296E
		3	0.000000E+00	0.000000E+00	0.000000E+00	0.000000E+00	-7.03296E	-7.03296E
		4	0.000000E+00	0.000000E+00	0.000000E+00	0.000000E+00	7.03296E	7.03296E

192.000	7	0.0000000E+00	0.5388947	0.0000000E+00	0.0000000E+00	0.0000000E+00	0.0000000E+00
	1	0.0000000E+00	0.0000000E+00	0.0000000E+00	0.0000000E+00	0.0000000E+00	0.0000000E+00
	2	0.0000000E+00	0.5843911	0.3458602	0.0000000E+00	0.0000000E+00	0.0000000E+00
	3	0.0000000E+00	0.0000000E+00	0.0000000E+00	0.0000000E+00	0.0000000E+00	0.0000000E+00
	4	0.0000000E+00	0.0000000E+00	0.0000000E+00	0.0000000E+00	0.0000000E+00	0.0000000E+00
	5	0.0000000E+00	0.5843911	0.3458604	0.0000000E+00	0.0000000E+00	0.0000000E+00
	6	0.0000000E+00	0.0000000E+00	0.0000000E+00	0.0000000E+00	0.0000000E+00	0.0000000E+00
	7	0.0000000E+00	1.279783	0.0000000E+00	0.0000000E+00	0.0000000E+00	0.0000000E+00

WISH

"GTSTRUDL" INPUT/OUTPUT FILE PRINTOUT

Problem: 7
Beam Selected: W6x15
End Conditions: Fixed-Free

Analyses taken at 3 Locations:

Location 1: 0 inches
Location 2: 12.6 inches
Location 3: 42 inches

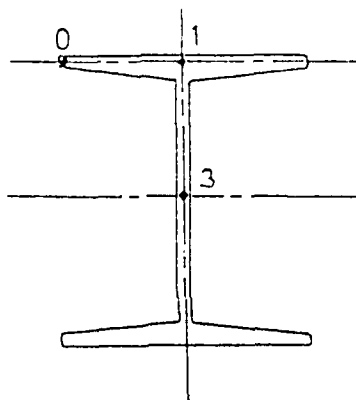
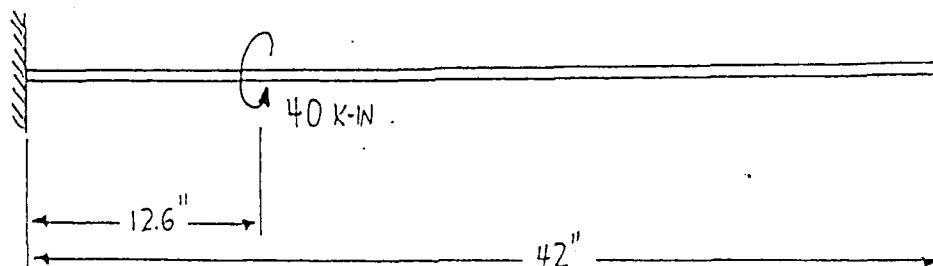

Pt. 0: Flange Tip
Pt. 1: Flange/Web Connection
Pt. 3: Web (at Neutral Axis)

3	0.0000000E+00	0.0000000E+00	0.0000000E+00	0.0000000E+00	0.0000000E+00	0.0000000E+00
4	0.0000000E+00	0.0000000E+00	0.0000000E+00	0.0000000E+00	0.0000000E+00	0.0000000E+00
5	0.0000000E+00	0.0000000E+00	0.0000000E+00	0.0000000E+00	0.0000000E+00	0.0000000E+00
6	0.0000000E+00	0.0000000E+00	0.0000000E+00	0.0000000E+00	0.0000000E+00	0.0000000E+00
7	0.0000000E+00	0.0000000E+00	0.0000000E+00	0.0000000E+00	0.0000000E+00	0.0000000E+00

FINISH

"GTSTRUDL" INPUT/OUTPUT FILE PRINTOUT

Problem: 8
Beam Selected: W8x67
End Conditions: Fixed-Free

Analyses taken at 3 Locations:

Location 1: 0 inches
Location 2: 32.4 inches
Location 3: 108 inches

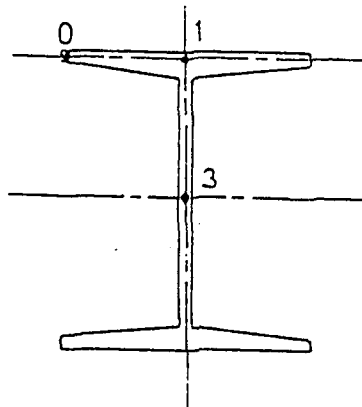
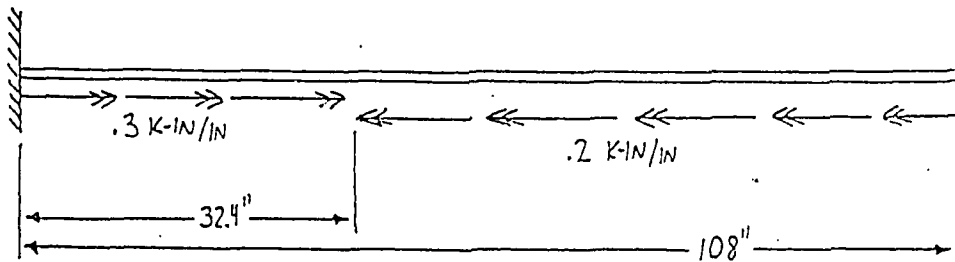

Pt. 0: Flange Tip
Pt. 1: Flange/Web Connection
Pt. 3: Web (at Neutral Axis)

RESTRICTED RIGHTS LEGEND

Use, duplication, or disclosure by the US Government is subject to restrictions as set forth in subparagraph (C) (1) (ii) of the Rights in Technical Data and Computer Software clause at DFARS 252.227-7013.

This computer software is an unpublished work containing valuable trade secrets owned by the Georgia Tech Research Corporation (GTRC). No access, use, transfer, duplication or disclosure thereof may be made except under a license agreement executed by GTRC or its authorized representatives and no right, title or interest thereto is conveyed or granted herein notwithstanding receipt or possession hereof. Decomilation of the object code is strictly prohibited.

Georgia Tech Research Corporation
Georgia Institute of Technology
Atlanta, Georgia 30332 U.S.A.

Copyright (C) GTRC
ALL RIGHTS RESERVED.

/SYS_SAVE=GTI_STRUCL:GTIST9101.CDB/IF_1=USERDAT.OS/IF_2=GTI_STRUCL:CTIST9101.OS/NO DUMP/IF_3=DYTEMP.TMP/TEMPORARY/IF_4=GTI_STRUCL:HEL
T_DS7POOL_INCR=18384/IF_7=PLOT/PIL.OS/WRITE/HOLE 0=-4
SYMBOL 'W6X67' 'FIXED-FREE'

*** G T S T R U D L ***

Table with columns: RELEASE DATE, VERSION, MOD LEVEL, COMPLETION NO.
DECEMBER 1981, 8101VAX, 1, 2031

**** ACTIVE UNITS - LENGTH WEIGHT ANGLE TEMPERATURE TIME
**** ASSUMED TO BE INCH POUND RADIAN FAHRENHEIT SECOND

UNITS KIPS INCHES
JOINT COORDINATES
'A' 0 0 0 SUPPORT

'B' 101 0 0 FREE
TYPE SPACE FRAME
MEMBER INCIDENCES

1 'A' 'B'
CONVX/NYS

E 2:000
C 11200

MEMBER PROPERTIES TABLE 'STEELW'

1 TABLE 'STEELW' 'W6X67'

LOADING 1

MEMBER LOAD

1 MOMENT X GLOBAL UNIFORM W .3 LA 0 LB 32.4

MEMBER LOAD

1 MOMENT X GLOBAL UNIFORM W -.3 LA 32.4 LB 100

STIFFNESS ANALYSIS

TIME FOR CONSISTENCY CHECKS FOR 1 MEMBERS 0.16 SECONDS

TIME FOR BANDWIDTH REDUCTION 0.00 SECONDS

TIME TO GENERATE 1 ELEMENT STIF. MATRICES 0.05 SECONDS

TIME TO PROCESS 2 MEMBER LOADS 0.09 SECONDS

TIME TO ASSEMBLE THE STIFFNESS MATRIX 0.05 SECONDS

TIME TO PROCESS 2 JOINTS 0.01 SECONDS

TIME TO SOLVE WITH 1 PARTITIONS 0.02 SECONDS

TIME TO PROCESS 2 JOINT DISPLACEMENTS 0.00 SECONDS

TIME TO PROCESS 1 ELEMENT DISTORTIONS 0.01 SECONDS

TIME FOR STATICS CHECK 0.01 SECONDS

OUTPUT BY MEMBER

LIST SECTION STRESSES POSITION ALL MEMBER 1 SECTION NS 3 0 32.4 100

RESULTS OF LATEST ANALYSES

PROBLEM - W6X67 TITLE - FIXED-FREE

ACTIVE UNITS INCH KIP RAD DECF SEC

INTERNAL MEMBER RESULTS

MEMBER SECTION STRESS

DISTANCE FROM START POSITION / AXIAL Y SHEAR Z SHEAR STRESS Y BENDING Z BENDING COMBINED NORMAL /

MEMBER 1

LOADING 1

Table with columns: DISTANCE FROM START, POSITION, AXIAL, Y SHEAR, Z SHEAR, STRESS, Y BENDING, Z BENDING, COMBINED NORMAL. Data rows for positions 1-7 and 1-6.

108.000

1	0.0000000E+00	0.0000000E+00	0.0000000E+00	0.0000000E+00	0.0000000E+00	0.0000000E+00	0.0000000E+00
2	0.0000000E+00	0.0000000E+00	0.0000000E+00	0.0000000E+00	0.0000000E+00	0.0000000E+00	0.0000000E+00
3	0.0000000E+00	0.0000000E+00	0.0000000E+00	0.0000000E+00	0.0000000E+00	0.0000000E+00	0.0000000E+00
4	0.0000000E+00	0.0000000E+00	0.0000000E+00	0.0000000E+00	0.0000000E+00	0.0000000E+00	0.0000000E+00
5	0.0000000E+00	0.0000000E+00	0.0000000E+00	0.0000000E+00	0.0000000E+00	0.0000000E+00	0.0000000E+00
6	0.0000000E+00	0.0000000E+00	0.0000000E+00	0.0000000E+00	0.0000000E+00	0.0000000E+00	0.0000000E+00
7	0.0000000E+00	0.0000000E+00	0.0000000E+00	0.0000000E+00	0.0000000E+00	0.0000000E+00	0.0000000E+00

FINISH

"GTSTRUOL" INPUT/OUTPUT FILE PRINTOUT

Problem: 9
Beam Selected: C10x20
End Conditions: Fixed-Free

Analyses taken at 3 Locations:

Location 1: 0 inches
Location 2: 18 inches
Location 3: 60 inches

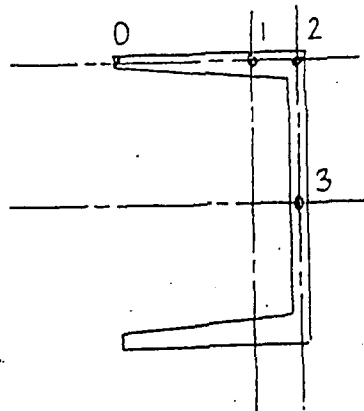
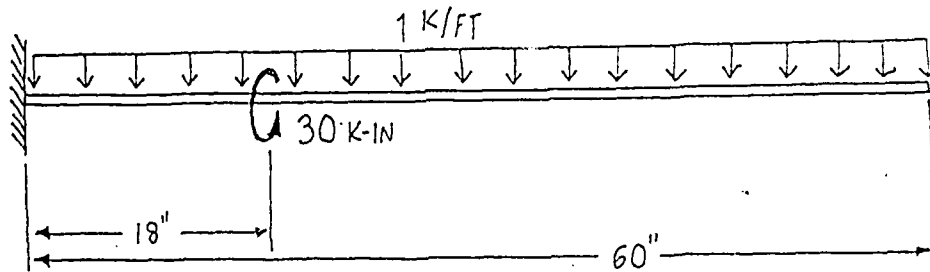

Pt. 0: Flange Tip
Pt. 1: Flange (at Neutral Axis)
Pt. 2: Flange/Web Connection
Pt. 3: Web (at Shear Center)

RESTRICTED RIGHTS LEGEND

Use, duplication, or disclosure by the US Government is subject to restrictions as set forth in subparagraph (C) (1) (ii) of the Rights in Technical Data and Computer Software clause at DFARS 252.227-7013.

THIS COMPUTER SOFTWARE IS AN UNPUBLISHED WORK CONTAINING VALUABLE TRADE SECRETS OWNED BY THE GEORGIA TECH RESEARCH CORPORATION (GTRC). NO ACCESS, USE, TRANSFER, DUPLICATION OR DISCLOSURE THEREOF MAY BE MADE EXCEPT UNDER A LICENSE AGREEMENT EXECUTED BY GTRC OR ITS AUTHORIZED REPRESENTATIVE AND NO RIGHT, TITLE OR INTEREST THEREIN IS CONVEYED OR GRANTED HEREIN NOTWITHSTANDING RECEIPT OR POSSESSION HEREOF. DECOMPILATION OF THE OBJECT CODE IS STRICTLY PROHIBITED.

Georgia Tech Research Corporation
Georgia Institute of Technology
Atlanta, Georgia 30332 U.S.A.

Copyright (c) GTRC
ALL RIGHTS RESERVED.

/SYS_SAVE(CT)_STRU1:CTIST9101.CDB/IF_1:USER0A1.DS/IF_2:CT)_STRU1:CTIST9101.DS/HODUMP/IF_3:DYTEMP.TMP/TEMPORARY/IF_4:CT)_STRU1:HEL
T.DS/POOL_INCR:IG384/IF_7:PLOTFIL.DS/WRITE/HOLE_0:-4
STRU1:CTOX20/FIXED-FREE

*** G T S T R U D L ***

Table with columns: RELEASE DATE, VERSION, MOD LEVEL, COMPLETION NO. Row: DECEMBER 1991, STOIYAX, 1, 2531

Table with columns: ACTIVE UNITS, LENGTH, WEIGHT, ANGLE, TEMPERATURE, TIME. Row: ASSUMED TO BE, INCH, POUND, RADIAN, FAHRENHEIT, SECOND

UNITS KIPS INCHES
JOINT COORDINATES
'A' 0 0 0 SUPPORT

'B' 80 0 0 FREE
TYPE SPACE FRAME
MEMBER INCIDENCES
1 'A' 'B'

CONSTANTS
E 29000
G 11200

MEMBER PROPERTIES TABLE 'STEEL78'

TABLE 'STEEL78' 'CTOX20'

LOADING 1

MEMBER LOAD

1 MOMENT X GLOBAL CONC JO L 18

MEMBER LOAD

1 FORCE Y GLOBAL UNIFORM W -.08333 LA 0 LB 60

STIFFNESS ANALYSIS

TIME FOR CONSISTENCY CHECKS FOR 1 MEMBERS 0.14 SECONDS

TIME FOR BANDWIDTH REDUCTION 0.00 SECONDS

TIME TO GENERATE 1 ELEMENT STIF. MATRICES 0.05 SECONDS

TIME TO PROCESS 2 MEMBER LOADS 0.20 SECONDS

TIME TO ASSEMBLE THE STIFFNESS MATRIX 0.03 SECONDS

TIME TO ACCESS 2 JOINTS 0.01 SECONDS

TIME TO SOLVE WITH 1 PARTITIONS 0.01 SECONDS

TIME TO PROCESS 2 JOINT DISPLACEMENTS 0.00 SECONDS

TIME TO PROCESS 1 ELEMENT DISTORTIONS 0.01 SECONDS

TIME FOR STATICS CHECK 0.00 SECONDS

OUTPUT BY MEMBER

LIST SECTION STRESSES POSITION ALL MEMBER 1 SECTION NS 3 0 18 60

RESULTS OF LATEST ANALYSES

PROBLEM - C10X20 TITLE - FIXED-FREE

ACTIVE UNITS INCH KIP RAD DECF SEC

INTERNAL MEMBER RESULTS

MEMBER SECTION STRESS

Table header: DISTANCE FROM START, POSITION, AXIAL, Y SHEAR, Z SHEAR, STRESS (Y BENDING, Z BENDING, COMBINED NORMAL)

MEMBER 1

LOADING 1

Main data table showing stress results for member 1 under loading 1. Columns include distance from start, position, axial, y shear, z shear, and various stress components.

80.000	1	0.0000000E+00	0.0000000E+00	0.0000000E+00	0.0000000E+00	-0.9078015E-06	-0.9078015E-06
	2	0.0000000E+00	0.0000000E+00	0.1972670E-07	0.0000000E+00	-0.9078015E-06	-0.9078015E-06
	3	0.0000000E+00	-0.2712408E-07	0.2357804E-07	0.0000000E+00	-0.9078015E-06	-0.9078015E-06
	4	0.0000000E+00	-0.4923629E-07	0.0000000E+00	0.0000000E+00	0.0000000E+00	0.0000000E+00
	5	0.0000000E+00	-0.2712408E-07	-0.2357804E-07	0.0000000E+00	0.9078015E-06	0.9078015E-06
	6	0.0000000E+00	0.0000000E+00	-0.1972670E-07	0.0000000E+00	0.9078015E-06	0.9078015E-06
	7	0.0000000E+00	0.0000000E+00	0.0000000E+00	0.0000000E+00	0.9078015E-06	0.9078015E-06

FINISH

"GTSTRUDL" INPUT/OUTPUT FILE PRINTOUT

Problem: 10
Beam Selected: C12x30
End Conditions: Fixed-Free

Analyses taken at 3 Locations:

Location 1: 0 inches
Location 2: 32.4 inches
Location 3: 108 inches

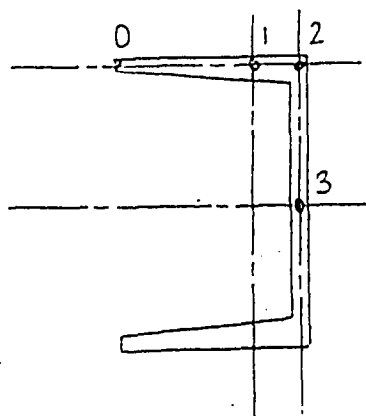
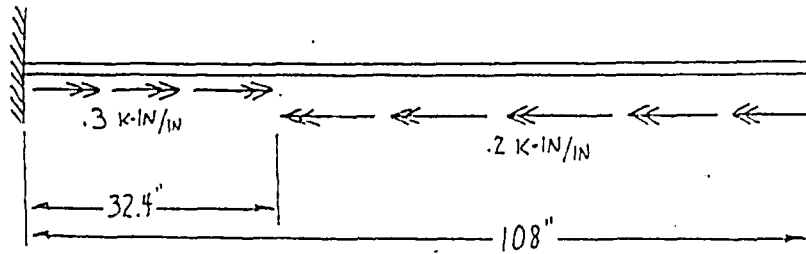

Pt. 0: Flange Tip
Pt. 1: Flange (at Neutral Axis)
Pt. 2: Flange/Web Connection
Pt. 3: Web (at Shear Center)

RESTRICTED RIGHTS LEGEND

Use, duplication, or disclosure by the US Government is subject to restrictions as set forth in subparagraph (C) (1) (ii) of the Rights in Technical Data and Computer Software clause at DFARS 252.227-7013.

THIS computer software is an UNPUBLISHED work containing valuable trade secrets owned by the Georgia Tech Research Corporation (GTRC). No access, use, transfer, duplication or disclosure thereof may be made except under a license agreement executed by GTRC or its authorized representatives and no right, title or interest thereto is conveyed or granted herein notwithstanding receipt or possession hereof. Decompilation of the object code is strictly prohibited.

Georgia Tech Research Corporation
Georgia Institute of Technology
Atlanta, Georgia 30332 U.S.A.

Copyright (c) GTRC
ALL RIGHTS RESERVED

/SYS_SAVE:CT1_STRUCL:CT1ST9101.CDB/IF_1:USERDAT.OS/IF_2:CT1_STRUCL:CT1ST9101.DS/NO DUMP/IF_3:DYTEMP.TMP/TEMPORARY/IF_4:CT1_STAUOL.HEL
T.OS/POOL INCR:16384/IF_7:PLOTFIL.OS/WRITE/HOLE 0:-4
STRUOL:CT1X30:FIXED-FREE

*** G T S T R U D L ***
RELEASE DATE VERSION MOD LEVEL COMPLETION NO.
DECEMBER 1991 9101VAX 1 2831

**** ACTIVE UNITS - LENGTH WEIGHT ANGLE TEMPERATURE TIME
**** ASSUMED TO BE INCH POUND RADIAN FAHRENHEIT SECOND

UNITS KIPS INCHES
JOINT COORDINATES
'A' 0 0 0 SUPPORT
'B' 108 0 0 FREE
TYPE SPACE FRAME
MEMBER INCIDENCES
1 'A' 0

CROSS SECTIONS
E 28000
G 11200

MEMBER PROPERTIES TABLE 'CHANNELS'

1 TABLE 'CHANNELS' 'CT1X30'

LOADING 1

MEMBER LOAD

1 MOMENT X GLOBAL UNIFORM W .3 LA 0 LB 32.4

MEMBER LOAD

1 MOMENT X GLOBAL UNIFORM W -.2 LA 32.4 LB 108

STIFFNESS ANALYSIS

TIME FOR CONSISTENCY CHECKS FOR 1 MEMBERS 0.16 SECONDS

TIME FOR BANDWIDTH REDUCTION 0.00 SECONDS

TIME TO GENERATE 1 ELEMENT STIF. MATRICES 0.10 SECONDS

TIME TO PROCESS 2 MEMBER LOADS 0.16 SECONDS

TIME TO ASSEMBLE THE STIFFNESS MATRIX 0.03 SECONDS

TIME TO PROCESS 2 JOINTS 0.00 SECONDS

TIME TO SOLVE WITH 1 PARTITIONS 0.03 SECONDS

TIME TO PROCESS 2 JOINT DISPLACEMENTS 0.01 SECONDS

TIME TO PROCESS 1 ELEMENT DISTORTIONS 0.01 SECONDS

TIME FOR STATICS CHECK 0.01 SECONDS

OUTPUT BY MEMBER

LIST SECTION STRESSES POSITION ALL MEMBER 1 SECTION NS 3 0 32.4 108

RESULTS OF LATEST ANALYSES

PROBLEM - C12X30 TITLE - FIXED-FREE

ACTIVE UNITS INCH KIP RAD DEG SEC

MEMBER RESULTS

MEMBER SECTION STRESS

DISTANCE FROM START POSITION / AXIAL Y SHEAR Z SHEAR STRESS Y BENDING Z BENDING COMBINED NORMAL /

MEMBER 1								
LOADING 1								
0.000	1	0.0000000E+00	0.0000000E+00	0.0000000E+00	0.0000000E+00	0.3422450E-15	0.3422450E-15	
	2	0.0000000E+00	0.0000000E+00	0.7698914E-17	0.0000000E+00	0.3422450E-15	0.3422450E-15	
	3	0.0000000E+00	-0.8832650E-17	0.8991320E-17	0.0000000E+00	0.3422450E-15	0.3422450E-15	
	4	0.0000000E+00	-0.1789982E-16	0.0000000E+00	0.0000000E+00	0.0000000E+00	0.0000000E+00	
	5	0.0000000E+00	-0.8832650E-17	-0.8991320E-17	0.0000000E+00	0.3422450E-15	0.3422450E-15	
	6	0.0000000E+00	0.0000000E+00	0.7698914E-17	0.0000000E+00	0.3422450E-15	0.3422450E-15	
	7	0.0000000E+00	0.0000000E+00	0.0000000E+00	0.0000000E+00	0.3422450E-15	0.3422450E-15	
32.400	1	0.0000000E+00	0.0000000E+00	0.0000000E+00	0.0000000E+00	0.2379529E-15	0.2379529E-15	
	2	0.0000000E+00	0.0000000E+00	0.7698914E-17	0.0000000E+00	0.2379529E-15	0.2379529E-15	
	3	0.0000000E+00	-0.8832650E-17	0.8991320E-17	0.0000000E+00	0.2379529E-15	0.2379529E-15	
	4	0.0000000E+00	-0.1789982E-16	0.0000000E+00	0.0000000E+00	0.0000000E+00	0.0000000E+00	
	5	0.0000000E+00	-0.8832650E-17	-0.8991320E-17	0.0000000E+00	0.2379529E-15	0.2379529E-15	
	6	0.0000000E+00	0.0000000E+00	0.7698914E-17	0.0000000E+00	0.2379529E-15	0.2379529E-15	
	7	0.0000000E+00	0.0000000E+00	0.0000000E+00	0.0000000E+00	0.2379529E-15	0.2379529E-15	

103.000

1	0.0000000E+00	0.0000000E+00	0.0000000E+00	0.0000000E+00	-0.5395073E-17	-0.5395073E-17
2	0.0000000E+00	0.0000000E+00	0.7698914E-17	0.0000000E+00	-0.5395073E-17	-0.5395073E-17
3	0.0000000E+00	-0.8832650E-17	0.8991320E-17	0.0000000E+00	-0.5395073E-17	-0.5395073E-17
4	0.0000000E+00	-0.1769982E-16	0.0000000E+00	0.0000000E+00	0.0000000E+00	0.0000000E+00
5	0.0000000E+00	-0.8832650E-17	-0.8991320E-17	0.0000000E+00	0.5395073E-17	0.5395073E-17
6	0.0000000E+00	0.0000000E+00	-0.7698914E-17	0.0000000E+00	0.5395073E-17	0.5395073E-17
7	0.0000000E+00	0.0000000E+00	0.0000000E+00	0.0000000E+00	0.5395073E-17	0.5395073E-17

FINISH

"GTSTRUDL" INPUT/OUTPUT FILE PRINTOUT

Problem: 11
Beam Selected: C5x9
End Conditions: Fixed-Free

Analyses taken at 3 Locations:

Location 1: 0 inches
Location 2: 12.6 inches
Location 3: 42 inches

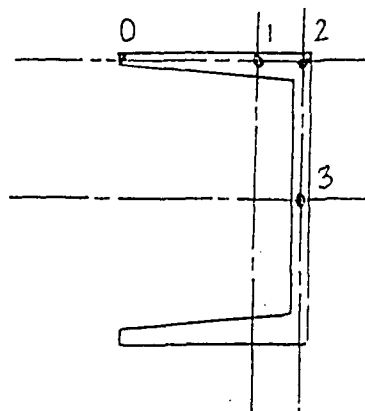
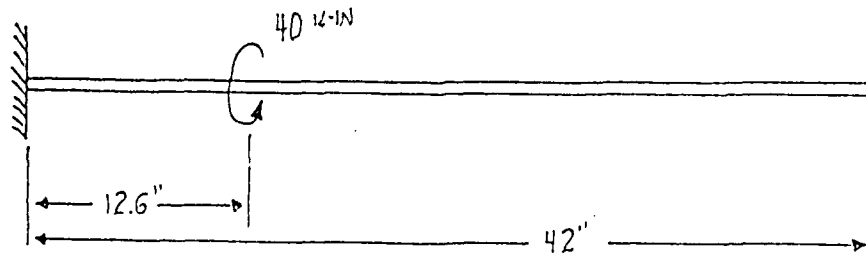

Pt. 0: Flange Tip
Pt. 1: Flange (at Neutral Axis)
Pt. 2: Flange/Web Connection
Pt. 3: Web (at Shear Center)

RESTRICTED RIGHTS LEGEND

Use, duplication, or disclosure by the US Government is subject to restrictions as set forth in subparagraph (C) (1) (ii) of the Rights in Technical Data and Computer Software clause at DFARS 252.227-7013.

This computer software is an unpublished work containing valuable trade secrets owned by the Georgia Tech Research Corporation (GTRC). No access, use, transfer, duplication or disclosure thereof may be made except under a license agreement executed by GTRC or its authorized representatives and no right, title or interest thereto is conveyed or granted herein notwithstanding receipt or possession hereof. Decompilation of the object code is strictly prohibited.

Georgia Tech Research Corporation
Georgia Institute of Technology
Atlanta, Georgia 30332 U.S.A.

Copyright (c) GTRC
ALL RIGHTS RESERVED.

/SYS_SAVE=GT1_STRUCL:CT1ST9101.COB/IF_1:USERDAT.DS/IF_2:GT1_STRUCL:GT1ST9101.DS/NO DUMP/IF_3:OYTEMP.TMP/TEMPORARY/IF_4:CT1_STRUCL:HEL
T.DS/POOL INCR=16384/IF_7:PLOTFIL.DS/WRITE/HOLE 0=4
STRUCL:CSX9 *FREE

*** C T S T R U D L ***
RELEASE DATE VERSION MOD LEVEL COMPLETION NO.
DECEMBER 1991 9101VAX 1 2831

**** ACTIVE UNITS LENGTH WEIGHT ANGLE TEMPERATURE TIME
**** ASSUMED TO BE INCH POUND RADIAN FAHRENHEIT SECOND

UNITS KIPS INCHES
JOINT COORDINATES
A 0 0 0 SUPPORT
B 0 0 0 FREE
TYPE SPACE FRAME
MEMBER INCIDENCES
1 2A 1B

CONSTRNYS
E 28000
C 11200

MEMBER PROPERTIES TABLE 'STEEL78'

TABLE 'STEEL78' 'CSX9'

LOADING 1

MEMBER LOAD

1 MOMENT X GLOBAL CONC 40 L 12.6

STIFFNESS ANALYSIS

TIME FOR CONSISTENCY CHECKS FOR 1 MEMBERS 0.15 SECONDS
TIME FOR BANDWIDTH REDUCTION 0.00 SECONDS
TIME TO GENERATE 1 ELEMENT STIF. MATRICES 0.09 SECONDS
TIME TO PROCESS 1 MEMBER LOADS 0.11 SECONDS
TIME TO ASSEMBLE THE STIFFNESS MATRIX 0.04 SECONDS
TIME TO PROCESS 2 JOINTS 0.00 SECONDS
TIME TO SOLVE WITH 1 PARTITIONS 0.05 SECONDS
TIME TO PROCESS 2 JOINT DISPLACEMENTS 0.01 SECONDS
TIME TO PROCESS 1 ELEMENT DISTORTIONS 0.01 SECONDS
TIME FOR STATICS CHECK 0.00 SECONDS

OUTPUT BY MEMBER

LIST SECTION STRESSES POSITION ALL MEMBER 1 SECTION NO 3 0 12.6 42

RESULTS OF LATEST ANALYSES

PROBLEM - CSX9 TITLE - FIXED-FREE

ACTIVE UNITS INCH KIP RAD DEGR SEC

INTERVAL MEMBER RESULTS

MEMBER SECTION STRESS

DISTANCE /-----/ STRESS /-----/
FROM START POSITION AXIAL V SHEAR T SHEAR Y BENDING Z BENDING COMBINED NORMAL

MEMBER 1

LOADING 1

		AXIAL	V SHEAR	T SHEAR	Y BENDING	Z BENDING	COMBINED NORMAL
0.000	1	0.000000E+00	0.000000E+00	0.000000E+00	0.000000E+00	-0.6386902E-15	-0.6386902E-15
	2	0.000000E+00	0.000000E+00	-0.8411243E-16	0.000000E+00	-0.6386902E-15	-0.6386902E-15
	3	0.1013893E-15	0.1029735E-15	0.000000E+00	0.000000E+00	-0.6386902E-15	-0.6386902E-15
	4	0.000000E+00	0.1713235E-15	0.000000E+00	0.000000E+00	0.000000E+00	0.000000E+00
	5	0.000000E+00	0.1013893E-15	0.1029735E-15	0.000000E+00	-0.6386902E-15	-0.6386902E-15
	6	0.000000E+00	0.000000E+00	-0.8411243E-16	0.000000E+00	-0.6386902E-15	-0.6386902E-15
	7	0.000000E+00	0.000000E+00	0.000000E+00	0.000000E+00	-0.6386902E-15	-0.6386902E-15
12.600	1	0.000000E+00	0.000000E+00	0.000000E+00	0.000000E+00	0.1660595E-15	0.1660595E-15
	2	0.000000E+00	0.000000E+00	-0.8411243E-16	0.000000E+00	0.1660595E-15	0.1660595E-15
	3	0.1013893E-15	0.1029735E-15	0.000000E+00	0.000000E+00	0.1660595E-15	0.1660595E-15
	4	0.000000E+00	0.1713235E-15	0.000000E+00	0.000000E+00	0.000000E+00	0.000000E+00
	5	0.000000E+00	0.1013893E-15	0.1029735E-15	0.000000E+00	0.1660595E-15	0.1660595E-15
	6	0.000000E+00	0.000000E+00	-0.8411243E-16	0.000000E+00	0.1660595E-15	0.1660595E-15
	7	0.000000E+00	0.000000E+00	0.000000E+00	0.000000E+00	0.1660595E-15	0.1660595E-15

3	0.000000E+00	0.1012233E-15	-0.1029723E-15	0.000000E+00	0.2042302E-14	0.2042302E-14
4	0.000000E+00	0.1712233E-15	0.000000E+00	0.000000E+00	0.000000E+00	0.000000E+00
5	0.000000E+00	0.1012233E-15	0.1029723E-15	0.000000E+00	-0.2042302E-14	-0.2042302E-14
6	0.000000E+00	0.000000E+00	0.8411223E-15	0.000000E+00	-0.2042302E-14	-0.2042302E-14
7	0.000000E+00	0.000000E+00	0.000000E+00	0.000000E+00	-0.2042302E-14	-0.2042302E-14

FINISH

"GTSTRUDL" INPUT/OUTPUT FILE PRINTOUT

Problem: 12
Beam Selected: MC18x42
End Conditions: Fixed-Free

Analyses taken at 3 Locations:

Location 1: 0 inches
Location 2: 96 inches
Location 3: 192 inches

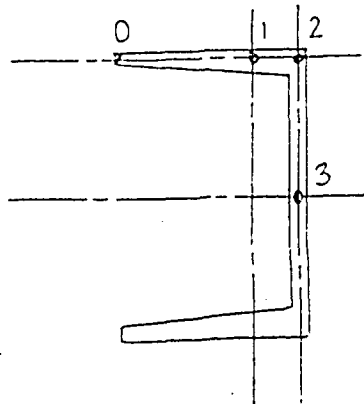
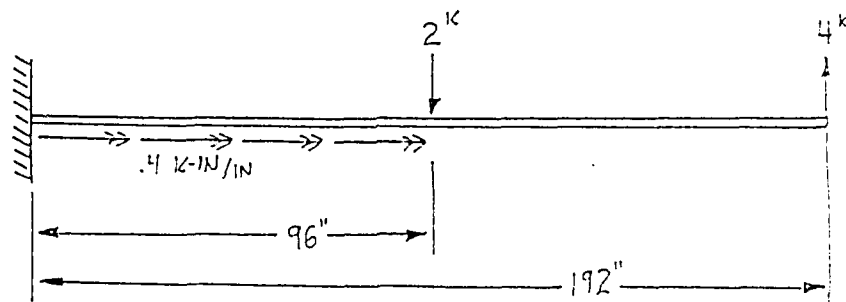

Pt. 0: Flange Tip
Pt. 1: Flange (at Neutral Axis)
Pt. 2: Flange/Web Connection
Pt. 3: Web (at Shear Center)

RESTRICTED RIGHTS LEGEND

Use, duplication, or disclosure by the US Government is subject to restrictions as set forth in subparagraph (C) (1) (ii) of the Rights in Technical Data and Computer Software clause at DFARS 252.227-7012.

This computer software is an unpublished work containing valuable trade secrets owned by the Georgia Tech Research Corporation (GTRC). No access, use, transfer, duplication or disclosure thereof may be made except under a license agreement executed by GTRC or its authorized representatives and no right, title or interest hereeto is conveyed or granted herein notwithstanding receipt or possession hereof. Decompilation of the object code is strictly prohibited.

Georgia Tech Research Corporation
Georgia Institute of Technology
Atlanta, Georgia 30332 U.S.A.

Copyright (c) GTRC
ALL RIGHTS RESERVED.

/SYS_SAVE:GTI_STRUDL:GTIST9101.CDB/IF_1:USERDAT.DS/IF_2:GTI_STRUDL:GTIST9101.DS/HODUMP/IF_3:DYTEMP.TMP/TEMPORARY/IF_4:GTI_STRUDL:HEL
T.DS/POOL INC=18384/IF_7:PLOTFIL.DS/WHITE/HOLE 0:4
STAUDI MC18X42 FIXED-FREE

*** G T I S T R U D L ***

RELEASE DATE	VERSION	MOD LEVEL	COMPLETION NO.
DECEMBER 1991	9101VAX	1	2831

ACTIVE UNITS	LENGTH	WEIGHT	ANGLE	TEMPERATURE	TIME
ASSUMED TO BE	INCH	POUND	RADIAN	FAHRENHEIT	SECOND

UNITS KIPS INCHES
JOINT COORDINATES
'A' 0 0 0 SUPPORT
'B' 192 0 0 FREE

TYPE SPACE FRAME
MEMBER INCIDENCES
1 'A' 'B'

COWSYANYS

E 28000

G 11200

MEMBER PROPERTIES TABLE 'CHANNELS'

1 TABLE 'CHANNELS' 'MC18X42'

LOADING 1

MEMBER LOAD

1 FORCE Y GLOBAL CONC P -2 L 96

MEMBER LOAD

1 FORCE Y GLOBAL CONC P 4 L 192

MEMBER LOAD

1 MOMENT X GLOBAL UNIFORM W .4 LA 0 LR 96

STIFFNESS ANALYSIS

TIME FOR CONSISTENCY CHECKS FOR 1 MEMBERS 0.17 SECONDS

TIME FOR BANDWIDTH REDUCTION 0.00 SECONDS

TIME TO GENERATE 1 ELEMENT STIF MATRICES 0.08 SECONDS

TIME TO PROCESS 3 MEMBER LOADS 0.17 SECONDS

TIME TO ASSEMBLE THE STIFFNESS MATRIX 0.02 SECONDS

TIME TO PROCESS 2 JOINTS 0.01 SECONDS

TIME TO SOLVE WITH 1 PARTITIONS 0.01 SECONDS

TIME TO PROCESS 2 JOINT DISPLACEMENTS 0.01 SECONDS

TIME TO PROCESS 1 ELEMENT DISTORTIONS 0.01 SECONDS

TIME FOR STATICS CHECK 0.02 SECONDS

OUTPUT BY MEMBER

LIST SECTION STRESSES POSITION ALL MEMBER 1 SECTION NS 3 0 96 192

RESULTS OF LATEST ANALYSIS

PROBLEM - MC18X42 TITLE - FIXED-FREE

ACTIVE UNITS INCH KIP RAD DEGF SEC

INTERNAL MEMBER RESULTS

MEMBER SECTION STRESS

DISTANCE FROM START	POSITION	AXIAL	Y SHEAR	X SHEAR	Y BENDING	X BENDING	COMBINED NORMAL
---------------------	----------	-------	---------	---------	-----------	-----------	-----------------

MEMBER 1

LOADING 1

0.000	1	0.0000000E+00	0.0000000E+00	0.0000000E+00	0.0000000E+00	-9.350650	-9.350650
	2	0.0000000E+00	0.0000000E+00	-0.9837794E-01	0.0000000E+00	-9.350650	-9.350650
	3	0.0000000E+00	0.1622590	-0.1168265	0.0000000E+00	-9.350650	-9.350650
	4	0.0000000E+00	0.2984913	0.0000000E+00	0.0000000E+00	0.0000000E+00	0.0000000E+00
	5	0.0000000E+00	0.1622590	0.1168265	0.0000000E+00	9.350650	9.350650
	6	0.0000000E+00	0.0000000E+00	0.9837794E-01	0.0000000E+00	9.350650	9.350650
	7	0.0000000E+00	0.0000000E+00	0.0000000E+00	0.0000000E+00	9.350650	9.350650
96.000	1	0.0000000E+00	0.0000000E+00	0.0000000E+00	0.0000000E+00	-6.233767	-6.233767
	2	0.0000000E+00	0.0000000E+00	-0.9837794E-01	0.0000000E+00	-6.233767	-6.233767
	3	0.0000000E+00	0.1622590	-0.1168265	0.0000000E+00	-6.233767	-6.233767
	4	0.0000000E+00	0.2984913	0.0000000E+00	0.0000000E+00	0.0000000E+00	0.0000000E+00

