

OBSERVING:
Revisit Your First Loves

PAGE 22

TIMING IS EVERYTHING:
See the Great Red Spot

PAGE 52

ASTROTOURISM:
Skywatching Down Under

PAGE 60

SKY & TELESCOPE

THE ESSENTIAL GUIDE TO ASTRONOMY

Dig Deep
into NASA's
Planetary Data

PAGE 28

**ASTRONOMER'S
WORKBENCH:**

Build a Zoom
Finderscope

PAGE 68

TEST REPORT:

Meade's New
4½-inch Premium
Refractor

PAGE 36

DARK ENERGY

The Enigma That Has Stumped
Astronomers for 20 Years

PAGE 14

MAY 2018

SKY
& TELESCOPE

skyandtelescope.com

Make Some History with a Tele Vue Telescope of Your Own!



Image courtesy of Don Bruns

Illustration of the Tele Vue-NP101i image identifying qualifying stars used to measure positional deviation due to the Sun's gravity.

It took Dr. Don Bruns two-and-a-half minutes to create history with a Tele

Vue-NP101i. During totality of the 2017 total solar eclipse, he imaged the star field around the Sun in an attempt to make the most accurate optical measurement to date of Einstein's prediction of starlight deflection. His goal was to use off-the-shelf equipment available to any amateur astronomer. Hear Don present his history-making results, and why he chose a Tele Vue telescope, at NEAF 2018; then stop by the Tele Vue booth to see the scope, speak with Don, and choose a Tele Vue telescope of your own! Whether you make family or scientific history with it, Tele Vue's line of APO refractors are heirloom-quality instruments, built in New York, to stand the test of time and challenges of space! Follow our blog at Televue.com for Don's and other Tele Vue owners' stories.

Some Tele Vue Telescopes have only a day to make history, others have a lifetime!



32 Elkay Dr., Chester, New York 10918 (845) 469-4551. televue.com

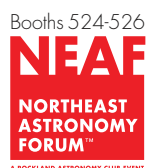



Eta Carina. ProLine PL16803 & CFW-5-7. Telescope Design: Philipp Keller. Image: Chart32 Team. Image Processing: Wolfgang Promper.

Astro's Next Generation: Kepler Cameras

Introducing the Kepler line of high-speed, low-noise cooled cameras from FLI!

The 2k x 2k Kepler KL400 cooled scientific CMOS camera offers a rare combination of high QE (95%), low-noise ($1.5e^-$), and fast frame rates (48 fps), making it one of the most sensitive cameras available for astronomy. Watch for new Kepler models including the KL4040 (52mm diagonal, 4k x 4k, 9 micron pixels) and KL6060 (87mm diagonal, 6k x 6k, 10 micron pixels).



Designed, manufactured and supported in the USA
www.flicamera.com
585-624-3760



© 2018 Finger Lakes Instrumentation, Inc. All rights reserved.

CONTENTS

SKY & TELESCOPE

THE ESSENTIAL GUIDE TO ASTRONOMY

FEATURES

Cover Story:

- 14** **The Dark Energy Enigma**
Twenty years after they discovered cosmic expansion is accelerating, astronomers are still working hard to understand why it's happening.
By Marcus Woo

- 22** **Big, Bold, Bright, and Beautiful**
Play celestial tourist and pick some low-hanging fruit tonight.
By Jerry Oltion

- 28** **Dig into NASA's Planetary Data System**
A vast treasure trove of unseen planetary images awaits intrepid amateurs. *By Emily Lakdawalla*

- 60** **A Journey to the Dark Site of the Earth**
A trip Down Under offered these observers their best views of some dramatic, deep-sky sights.
By Jurij Stare & Zbigniew Zembaty

S&T TEST REPORT

- 36** **Meade's 115mm ED Triplet**
By Rod Mollise

May 2018 VOL. 135, NO. 5

48

OBSERVING

- 41** **May's Sky at a Glance**
- 42** **Lunar Almanac & Sky Chart**
- 43** **Binocular Highlight**
By Mathew Wedel
- 44** **Planetary Almanac**
- 45** **Under the Stars**
By Fred Schaaf
- 46** **Sun, Moon & Planets**
By Fred Schaaf
- 48** **Celestial Calendar**
By S. N. Johnson-Roehr
- 52** **Exploring the Solar System**
By J. Kelly Beatty
- 54** **Deep-Sky Wonders**
By Sue French
- 57** **Going Deep**
By Ted Forte

COLUMNS / DEPARTMENTS

- 4** **Spectrum**
By Peter Tyson
- 6** **From Our Readers**
- 7** **75, 50 & 25 Years Ago**
By Roger W. Sinnott
- 8** **News Notes**
- 12** **Cosmic Relief**
By David Grinspoon
- 68** **Astronomer's Workbench**
By Jerry Oltion
- 70** **New Product Showcase**
- 74** **Gallery**
- 83** **Event Calendar**
- 84** **Focal Point**
By Mike Brake

Find us on Facebook & Twitter

ON THE COVER

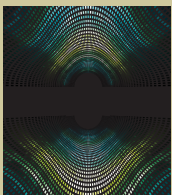

Dark energy makes space's "grid" size grow faster with time (evoked, not shown).

HAKKIARSLAN / GETTY IMAGES

ONLINE

TIPS FOR BEGINNERS

New to astronomy? From learning the night sky to tips on buying your first telescope, here's everything you need to jump into the fun.

skyandtelescope.com/letsgo

ASTRONOMY Q&A

From dark matter and black holes to comet observing and how to clean eyepieces, get your astronomy 101 questions answered.

skyandtelescope.com/faq

ASTRONOMY EVENTS

Check out our events calendar for upcoming star parties and other events — or add your own.

skyandtelescope.com/astronomy-events

SKY & TELESCOPE (ISSN 0037-6604) is published monthly by Sky & Telescope, a division of F+W Media, Inc., 90 Sherman St., Cambridge, MA 02140-3264, USA. Phone: 800-253-0245 (customer service/subscriptions), 888-253-0230 (product orders), 617-864-7360 (all other calls). Fax: 617-864-6117. Website: skyandtelescope.com. ©2018 F+W Media, Inc. All rights reserved. Periodicals postage paid at Boston, Massachusetts, and at additional mailing offices. Canada Post Publications Mail sales agreement #40029823. Canadian return address: 2744 Edna St., Windsor, ON, Canada N8Y 1V2. Canadian GST Reg. #R128921855. POSTMASTER: Send address changes to Sky & Telescope, PO Box 420235, Palm Coast, FL 32142-0235. Printed in the USA.

SEE THE UNIVERSE LIVE AND IN COLOUR WITH

MALLINCAM SKYRAIDER

DS2.3PLUS—2.3 Megapixel

The SkyRaider DS2.3PLUS video/imager/autoguider is the newest in the SkyRaider family of astronomical video/imaging cameras. It includes the very latest Sony EXmor CMOS sensor to deliver the increased sensitivity needed for astronomical observation and imaging. The new SkyRaider DS2.3PLUS is ready for the most demanding applications in video/imaging astronomy, excelling at live observing of both deep-sky and solar system objects. The MallinCam SkyRaider DS2.3PLUS is the most versatile video/imaging camera ever created for computer use. Astronomical objects can be observed live while images are captured or video is being recorded.

Features:

- Star registration system for live stacking on the fly
- Ideal for all motorized alt-az mounted telescopes
- Support includes full trigger mode
- Built-in memory
- Global shutter
- CDS (correlated double sampling)
- 2.35-megapixel CMOS ceramic colour sensor

- 13.4mm diagonal (WUXGA mode)
- Number of effective pixels: 1936 (H) x 1216 (V) WUXGA mode
- Transfer method: all-pixel scan
- Full HD
- Hand-selected scientific grade class 0 sensor
- Sealed multicoated optical window
- FPS/resolution: up to 30 @1936 x 1216 (computer performance dependent)
- Progressive scan, global shutter
- Pixel (μm): 5.86 square
- Connectivity USB 3.0
- Sensor gain: variable to 50x
- Sensor G sensitivity: 1000mv @1/30s with IR filter
- Sensor G sensitivity without IR: 2000mv
- Binning: 1 x 1
- Sensor: 2.35M/IMX302 colour sensor 1936 x 1216
- Size (mm) 1/1.2" (7.20 x 4.5) WUXGA mode
- Guiding: ST4 standard protocol

- All-aluminum construction, precision CNC machining
- Handcrafted electronics assembly
- One USB 3 cable operation
- 1.25" adapter
- 5-metre-long (16 feet) USB 3 high-grade cable

The most versatile video/imaging camera ever created

\$899.99

DS16C— 16 Megapixel

The MallinCam SkyRaider DS16C utilizes a 16.3 effective megapixel ceramic CMOS grade 1 sensor. The new sensor measures 22mm diagonally. The camera delivers high-resolution images using all telescope types for those spectacular large astronomical objects. This sensor has significantly improved sensitivity in the near-infrared light region, and it utilizes square 3.80 μm pixels with high signal-to-noise ratio.

Features:

- Global shutter
- 12 bits
- Star registration system for live stacking on the fly
- Ideal for motorized alt-az mounted telescopes
- Support includes full trigger mode
- Built-in memory
- CDS (correlated double sampling)
- 16.3-megapixel CMOS ceramic colour sensor
- 22mm diagonal
- Number of effective pixels: 4656 x 3518 (16,379,808)

- Transfer method: all-pixel scan
- Progressive scan
- Full HD support
- Hand-selected scientific grade class 1 sensor
- Sealed multicoated no IR optical window
- 3.80-micron-square pixels
- Connectivity USB 3.0 (USB 2 compatible)
- Sensor gain: variable to 20x
- Sensor G sensitivity: 2413mv @1/30s
- Binning resolution: 4640 x 3506, 2304 x 1750, 1536 x 1168
- Sensor: Panasonic v Maicovicon series super high performance
- Size (mm) 4/3" (17.6472 x 13.3228)
- 4K2K support
- Full scan, any size cropping
- Aspect ratio: 4:3
- Guiding: ST4 standard protocol
- All-aluminum construction, precision CNC machining
- Handcrafted electronics assembly
- Single USB 3 cable operation
- 5-metre-long (16 feet) premium USB 3 cable

\$1,399.99



MALLINCAM

Prices are in U.S. Dollars

MallinCam.com

SEE THE UNIVERSE LIVE AND IN COLOUR
56-5450 Canotek Rd.
Ottawa, Ontario, Canada K1J 9G4
613-749-7592

Available in the U.S.: **Jack's Astro Accessories, Louisiana.** <http://mallincamUSA.com>

In Canada: **Khan Scope Centre, 3243 Dufferin St., Toronto, Ontario.** www.khanscope.com

Focus Scientific, 911 Carling Ave., Ottawa, Ontario. www.focusscientific.com

A Whale of a Mystery



LAST MONTH I WROTE about how amazing it is that the universe is so transparent that we can perceive galaxies and other objects billions of light-years away. We can see everything!

Except we can't. In fact, we can't see most of what's out there. If we could plop the universe on a scale, all we can observe with our eyes and instruments would "weigh" just 5% or so of the total. The rest is stuff invisible to us — dark matter and dark energy, comprising about 26% and 69%, respectively. It's like we're peering into a large aquarium and marveling at a clownfish while somehow missing the giant squid and blue whale *right behind it*.

We learned the blue whale existed in 1998, when two independent teams stumbled upon it. They shared the 2011 Nobel Prize in Physics for realizing, while studying distant supernovae, that the universe's expansion is speeding up. *Something* is causing that acceleration, and countering the lassoing effects of matter, dark and otherwise.

Twenty years after its discovery, we still have few clues as to what dark energy is. Is it some property intrinsic to space itself that grows as space does? Might it be a new "fifth force," after gravity, electromagnetism, and the strong and weak nuclear forces? Does it call for an entirely new understanding of gravity?

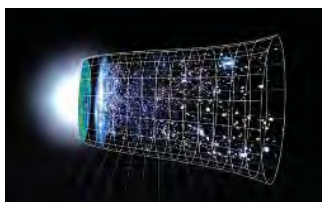

From the Big Bang to now: the universe's expansion in a nutshell

Desperate for an answer, researchers have invoked everything at their disposal to attempt to pin it down, including such mind-bending notions as string theory and the multiverse. They're trying their utmost to wrap the tightest constraints they can manage around what this strange "antigravity" might be, but those bounds remain loose enough that the whale keeps slipping free, eluding their grasp.

This makes me smile. If there were a Grand Creator (don't worry, I'm not going there), I can almost imagine it looking on and winking: "You Earthlings pride yourselves on how much you've figured out about the cosmos. Congratulations. Now, try your hand at *this*." That dark energy has stumped our top theorists, at least so far, is a healthy reminder that, clever as we are, we don't know everything. Do some puzzles actually exceed our ability to solve them?

We could use another Einstein, a galloping genius of an entirely different stripe. In the meantime, as Marcus Woo explains in our cover story on page 14, we're doing everything we can to get to the bottom of dark energy. It's rather consequential: As Woo notes, nothing short of "the characteristics of spacetime, the fate of the universe, even the nature of reality itself" depend on it.

Editor in Chief

SKY & TELESCOPE

The Essential Guide to Astronomy

Founded in 1941 by Charles A. Federer, Jr. and Helen Spence Federer

EDITORIAL

Editor in Chief Peter Tyson
Senior Editors J. Kelly Beatty, Alan M. MacRobert
Equipment Editor Sean Walker
Science Editor Camille M. Carlisle
News Editor Monica Young
Associate Editor S. N. Johnson-Roehr
Observing Editor Diana Hannikainen
Project Coordinator Bud Sadler
Digital Content Strategist Janine Myszk

Senior Contributing Editors

Robert Naeye, Roger W. Sinnott

Contributing Editors

Howard Banich, Jim Bell, Trudy Bell, John E. Bortle, Greg Bryant, Thomas A. Dobbins, Alan Dyer, Tom Field, Tony Flanders, Ted Forte, Sue French, Steve Gottlieb, David Grinspoon, Ken Hewitt-White, Johnny Horne, Bob King, Emily Lakdawalla, Jerry Lodriguss, Rod Mollise, James Mullaney, Donald W. Olson, Jerry Olton, Joe Rao, Dean Regas, Fred Schaaf, Govert Schilling, William Sheehan, Mike Simmons, Mathew Wedel, Alan Whitman, Charles A. Wood, Robert Zimmerman

Contributing Photographers

P. K. Chen, Akira Fujii, Robert Gendler, Babak Tafreshi

ART & DESIGN

Art Director Terri Dubé
Illustration Director Gregg Dinderman
Illustrator Leah Tiscione

ADVERTISING

VP, Advertising Sales Kevin D. Smith
Advertising Sales Director Tim Allen
Advertising Coordinator Connie Kostrzewa

F+W MEDIA

Chief Executive Officer Greg Osberg
Chief Financial Officer Jennifer Graham
SVP / GM — F+W Outdoors & Small Business Groups Ray Chelstowski
Managing Director — F+W International James Woollam
VP, General Counsel Robert Sporn
VP, Human Resources Gigi Healy
VP, Manufacturing & Logistics Phil Graham
Newsstand Sales Scott T. Hill, Scott.hill@procirc.com

NASA'S GODDARD SPACE FLIGHT CENTER

Editorial Correspondence (including permissions, partnerships, and content licensing): Sky & Telescope, 90 Sherman St., Cambridge, MA 02140-3264, USA. Phone: 617-864-7360. E-mail: editors@skyandtelescope.com. Website: skyandtelescope.com. Unsolicited proposals, manuscripts, photographs, and electronic images are welcome, but a stamped, self-addressed envelope must be provided to guarantee their return; see our guidelines for contributors at skyandtelescope.com.

Advertising Information: Tim Allen
 773-551-0397, Fax: 617-864-6117.
 E-mail: tallen@skyandtelescope.com
 Web: skyandtelescope.com/advertising

Customer Service: Magazine customer service and change-of-address notices: skyandtelescope@emailcustomerservice.com
 Phone toll-free U.S. and Canada: 800-253-0245.
 Outside the U.S. and Canada: 386-597-4387.

Visit shopatsky.com
 Your source for the best astronomy resources
 Shop at Sky customer service:
 skyprodservice@skyandtelescope.com
 888-253-0230.

Subscription Rates: U.S. and possessions: \$42.95 per year (12 issues); Canada: \$49.95 (including GST); all other countries: \$61.95, by expedited delivery. All prices are in U.S. dollars.

Newsstand and Retail Distribution: Curtis Circulation Co., 201-634-7400.

The following are registered trademarks of F+W Media, Inc.: *Sky & Telescope* and logo, *Sky and Telescope*, The Essential Guide to Astronomy, Skyline, Sky Publications, skyandtelescope.com, skypub.com, *SkyWatch*, Scanning the Skies, *Night Sky*, *SkyWeek*, and ESSCO.

GET READY FOR MAKSIMUM SAVINGS!

Save up to \$150 on Sky-Watcher Maksutov's and Quattro imaging Newtonians during April!

Regardless of whether you prefer visual astronomy or astrophotography, Sky-Watcher USA has something for everybody – including some spectacular savings. For the month of April our entire Maksutov and Quattro lines are on sale. From the ultra-portable 90mm Mak-Cassegrain, all the way up to our impressive 12" Quattro imaging Newtonian, you can get crisp views and flat fields for less.

From **April 1, 2018 through April 30, 2018**, all of our Maksutovs and Quattro imaging Newtonians will be on sale. Don't miss out on some of the best savings of the year!





	Regular price	Sale price	You save
90mm Mak-Cassegrain	\$220	\$190	\$30
102mm Mak-Cassegrain.....	\$265	\$230	\$35
127mm Mak-Cassegrain.....	\$435	\$400	\$35
150mm Mak-Cassegrain.....	\$750	\$680	\$70
180mm Mak-Cassegrain.....	\$1200	\$1075	\$125
190mm Mak-Newtonian	\$1550	\$1400	\$150
8" Quattro.....	\$640	\$600	\$40
10" Quattro.....	\$815	\$760	\$55
12" Quattro.....	\$1279	\$1189	\$90

©2018 Sky-Watcher USA. Specifications subject to change without notice. 2018004. If you're in New York on April 21-22, come visit us at the Northeast Astronomy Forum!

Sky-Watcher® USA
Be amazed.

For information on all of our products and services, or to find an authorized Sky-Watcher USA dealer near you, just visit www.skywatcherusa.com.

  Don't forget to follow us on Facebook and Twitter!



▲ It takes a sturdy mount to handle these beefy 20×100 binoculars. Ray Harris made this setup some 20 years ago.

Seeing Double

I enjoyed Matt Wedel’s Binocular Tour “Open Clusters Galore” (S&T: Jan. 2018, p. 60). We friends of binos always welcome interesting targets with added context. Please keep them coming.

Russ Boatright • Aledo, Texas

Having read Jerry Oltion’s take on binocular mounts (S&T: Feb. 2018, p. 72), I thought your readers might appreciate the one I assembled 20 years ago for my 20×100 binoculars. I built a custom cradle and mounted it in old Celestron C11 fork arms, which I attached to a Tuthill Isostatic Equatorial Mount. The result was a perfect instrument for tracking and observing the solar eclipse this past August from my observing site in Tennessee. I used the compass on my iPhone to get a rough polar alignment the morning of the eclipse, and the mount tracked the Sun flawlessly all day. I’ve been using this setup for 20 years for both night and day observing, but this was my first opportunity to use it to witness totality. I hope it’s not my last.

Ray Harris • Macungie, Pennsylvania

August’s “Cosmic Communion”

Highest compliments to David Grinspoon on his “Cosmic Communion” account of last summer’s solar eclipse (S&T: Jan. 2018, p. 14). It was the most lyrical, descriptively accurate record of the event I have read anywhere. Perhaps it helps that, in addition to his chops as an astrobiologist, he is an author, musician — and poet. I am referring many of my friends and acquaintances to his S&T article, because his words succeed where my words fall short in describing that exhilarating experience.

Jim Ribble
Gainesville, Georgia

Seeing in the Ultraviolet?

Could you publish an article about astronomers who can see ultraviolet light because they have had their natural lenses removed? They could show how much extra they see by flipping a UV-blocking filter in a filter slide and making sketches of familiar objects — the “with” and “without” versions would be fascinating. It would also be interesting to discuss which objects give off ultraviolet emission lines or more UV light in general, like maybe some supernova remnants.

Kathryn Hudson
Devon, United Kingdom

Dr. Mario Motta replies: *It’s well known that patients can see blue better after they have cataract surgery, but that’s because, being yellow in color, a cataract acts as a blue-blocking filter. Although our eyes have three color receptors, one of which is blue sensitive, we have no mechanism to see ultraviolet light because this blue-light receptor has only a very slight sensitivity to near-ultraviolet light. So maybe a few of these photons will register, but certainly not enough to be “seeing UV.”*

The Measure of Mount Wilson

In her interesting article on the changing Sun (S&T: Jan. 2018, p. 18), Monica Bobra comments, “The Mount Wilson Observatory sits atop a hill that overlooks the sprawling city of Los Angeles.” Let me point out that Mount Wilson, which is 1,740 meters (5,710 feet) tall, is a stellar part (pardon the pun) of the San Gabriel Mountains.

Dick Terrill
Torrance, California

More on Surface Brightness

In tackling the often-misunderstood nuances of an object’s surface brightness (S&T: Dec. 2017, p. 28), Jerry Oltion notes that looking through a 100-mm-aperture telescope at 10×

would deliver only 36 times as much light through a 6-mm eye pupil as a naked-eye view. It’s true that the 6-mm pupil has the effect of stopping the scope down to 60 mm, but that reduced aperture still would gather 100 times more light than an unaided eye with a 6-mm pupil.

Keith Brescia
Falls Church, Virginia

Oltion deals with lots of simple examples of retinal illumination, but he forgets to mention that a telescope’s concentration of the illumination level at the exit pupil can lead to “frying” problems at the eye’s cornea, not the retina. When used for viewing the Sun, a telescope serves as a solar concentrator. Eye safety standards exist for both corneal and retinal illumination levels, so both need to be considered with optical systems such as those discussed in the article.

If a solar filter transmits too much light, then the diameter ratio of the scope’s front filter and its exit pupil will dictate much higher corneal illumination, perhaps in the dangerous level category due to the ratios of the two areas. That is why small “solar filters” for use near the eyepiece are no longer sold, as the increased heat level on the filters was dangerous. The user’s eye

needs the same protection in certain circumstances.

David Stoltzmann
Prescott Valley, Arizona

“**Jerry Olton replies:** You’re correct that the corneal illumination can exceed retinal illumination under certain circumstances, but after doing some math and confirming it with another optical engineer I’ve concluded that the danger is minimal under any normal viewing scenario.

The intensity of light per unit area at the exit pupil is completely independent of aperture — it depends solely upon magnification. As aperture increases, the irradiated exit pupil grows in diameter, but the intensity of the light per unit of area doesn’t change; it changes only with magnification.

Solar filter material designed for telescopic use typically has an optical density of 5, which means it reduces the light throughput by 10^{-5} , or $1/100,000$. For a telescope to concentrate enough light to counter the attenuation of a solar filter, its magnification

must concentrate the light by a factor of 10^5 .

This 100,000-fold intensity increase is simply the magnification squared, which means a magnification of 316 \times . So it’s probably a good rule of thumb to not look at the Sun telescopically at greater than 300 \times .

Seeing Mercury in Daylight

In his article about observing the poles of Mercury (S&T: Jan. 2018, p. 52), William Sheehan states that Giovanni Schiaparelli observed Mercury “in broad daylight.” How was that done?

Dick Marti
Tifton, Georgia

“**William Sheehan replies:** Before Schiaparelli, observers were confined to viewing Mercury in twilight — through the thickest and most turbulent part of Earth’s atmosphere. Schiaparelli realized the seeing might be better when Mercury

was high in the daytime sky. Of course, it’s impossible to see the planet then with the naked eye. However, because his telescope had setting circles and a clock drive, Schiaparelli could point it to the right place in the sky and study Mercury for hours at a time.

FOR THE RECORD

- The events listed in the table for the total lunar eclipse (S&T: Jan. 2018, p. 49) are given in standard (not daylight) time.
- In the caption below the Periodic Table of Cosmic Origins (S&T: Feb. 2018, p. 37), promethium should be identified as Pm rather than Pc.
- The discussion of returning a 2006 balloon-borne experiment to Earth (S&T: Feb. 2018, p. 19) should note that engineers had to send a second radio signal to separate the parachute from the payload (not the balloon) once it had landed.

SUBMISSIONS: Write to *Sky & Telescope*, 90 Sherman St., Cambridge, MA 02140-3264, U.S.A. or email: letters@skyandtelescope.com. Please limit your comments to 250 words; letters may be edited for brevity and clarity.

75, 50 & 25 YEARS AGO by Roger W. Sinnott

1943



◀ May 1943

Oregon Meteorite “I was coming home,” said Mr. Hughes, “from where I had been cutting wood for the Willamette school. I noticed this big rock for the first time but didn’t think anything of it. . . . I sat down on the rock which was very flat and about 18 inches above ground. . . . Then I picked up a white stone and started to hammer on the rock. It rang like a bell. . . .”

“After months of urging by his wife, Mr. Hughes went to work on a crude truck with which to move the huge mass to a spot near his house three quarters of a mile away. He trusted no one to help him aside from his wife, his 15-year-old boy, and his horse. He made the truck of logs and mounted it on ungainly wheels sawed from a tree trunk.”

The 16-ton Willamette meteorite found in 1902 by Welsh woodsman Ellis Hughes attracted people from far and wide, each paying 25 cents for a look. J. Hugh Pruett goes on

to tell how Hodges lost a court case regarding ownership of the massive find — and how it ended up at the American Museum of Natural History in New York City.

◀ May 1968

Relativity Test “Irwin I. Shapiro and his colleagues at Massachusetts Institute of Technology’s Lincoln Laboratory [have] announced promising results from a novel radar astronomy test. . . . Einstein’s general relativity theory says that the speed of a light wave (or radio wave) depends on the strength of the gravitational field along its path. On this basis, when a radar pulse is sent past the sun to Mercury or Venus at superior conjunction, the round-trip delay should be increased by about 0.0002 second.

“[Shapiro reports that the] anticipated ‘excess delay’ was confirmed to within the limits of observational error, or about 20 percent. Further measurements . . . may reduce this uncertainty to five percent.”

◀ May 1993

Opposites Merge “Many amateur astronomers know the spiral galaxy M64 in Coma Berenices as the Black-eye galaxy because of a dark lane of dust . . . that arches over its bright nucleus. However, what has intrigued Robert Braun (Netherlands Foundation for Research in Astronomy) and his colleagues . . . is the surprising presence of two independent disks of gas rotating in opposite directions, the first such system to be discovered. . . .

“[Braun and his team suggest] that the unique configuration of M64 resulted from the merger of two counterrotating galaxies and that the odd behavior will end in about a billion years. By that time all the gas in both disks will have fallen toward the nucleus and fueled star formation, though the resulting stars may ‘remember’ the counterrotation of the two disks.”

Some other galaxies show counterrotating populations of stars, or of stars vs. gas. The causes are far from settled.

1968

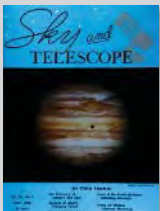

1993





SPACE

Successful Falcon Heavy Launch

AT 3:45 P.M. EST on February 6th, SpaceX successfully launched its Falcon Heavy from the Kennedy Space Center in Florida. Currently the world's most powerful rocket, it's capable of carrying 141,000 pounds to Earth orbit, more than twice the capacity of the next most powerful rocket, United Launch Alliance's Delta IV Heavy.

About eight minutes after liftoff, the rocket's side boosters landed in perfect synchrony on concrete pads not far from the launch complex. These boosters had seen space once before, but they won't be used again, as SpaceX plans to upgrade the rockets.

The center core, which was supposed to land on a drone ship in the Atlantic Ocean, ran out of ignition fluid and hit the water at 100 meters per second (300 mph) about 100 meters (300 feet) from the ship.

Despite this hitch, the mission was deemed a success. The payload that SpaceX CEO Elon Musk chose to send into space — Musk's own Tesla Roadster — reached an elliptical orbit

▲ The Falcon Heavy lifted off from Launch Complex 39-A at the Kennedy Space Center in Florida on February 6th.

around the Sun that extends slightly past the orbit of Mars to an aphelion of 1.67 astronomical units. (Typically, a demo flight would carry weighted ballast such as concrete, but Musk opted to send his car instead.)

SpaceX unveiled plans for a Falcon Heavy in 2011 with an initial flight set for 2014, but it experienced a series of delays. Now taking customers, SpaceX says a ride will start at an affordable \$90 million, a quarter of what it costs to launch a Delta IV Heavy. The Falcon Heavy opens a new class of payload, Musk said, capable of sending 37,000-pound payloads to Mars and 7,700-pound payloads to Pluto. SpaceX doesn't plan to have it carry humans, though. For now, the rocket's next tasks include launching satellites for a Saudi Arabian communications company and the U.S. Air Force.

■ PAULINE ACALIN

COSMOLOGY

Dark Energy Survey Releases Three-Year Data

SCIENTISTS PRESENTED the first data release of the Dark Energy Survey (DES) at January's American Astronomical Society meeting in Washington, D.C., which contains observations collected between mid-2013 and early 2016. Preliminary results include discoveries around the Milky Way to new constraints on cosmological parameters.

The Dark Energy Camera at the 4-meter Victor Blanco Telescope of the Cerro Tololo Inter-American Observatory in Chile sports 62 CCDs with a total of 570 million pixels. The survey's first three years cover about 5,000 square degrees — one-eighth of the sky — and catalog 310 million galaxies and 80 million stars.

Incredibly sensitive DES data led to the discovery of 11 new stellar streams, tidally stretched remains of dwarf galaxies around the Milky Way (*S&T*: April 2017, p. 22). The new streams are located between 40,000 and 165,000 light-years away.

Cosmologists are also using DES to map dark matter. The invisible stuff gravitationally lenses light, systematically distorting the shapes of distant galaxies. So far, scientists have analyzed the shapes of 26 million galaxies observed in DES's first year of operation.

Combining the DES weak-lensing results with other data yields an independently measured value for the current expansion rate of the universe, known as the *Hubble constant* (see page 20). The new value, which lies between 66.2 and 68.4 kilometers per second per megaparsec, is consistent with the value derived from the Planck mission's measurements of the cosmic background radiation, but it's still lower than that obtained from observations of Cepheid variable stars and Type Ia supernovae.

■ GOVERT SCHILLING

● For more details on the Dark Energy Survey and its results, visit <https://is.gd/darkenergysurveyDR1>.

STARS

Hefty Stars Prompt Birth Debate

A NEW STUDY FOUND more massive stars than expected in an intense region of star-formation, begging the question: Does the process of star formation always happen the same way?

As gas clouds collapse into stars, they fragment, producing many smaller stars and only a few bigger ones. Astronomers have long debated what factors might affect this process.

The Tarantula Nebula (30 Doradus) is the perfect testing ground. The windswept hub of giant stars-to-be is located more than 160,000 light-years away in the Large Magellanic Cloud, where conditions mimic those of the universe's early years.

Fabian Schneider (University of Oxford, UK) and colleagues used the FLAMES spectrograph on the Very Large Telescope in Chile to collect spectra for 800 of the nebula's stars. The team then calculated the region's *initial mass function* based on 247 single stars with at least 15 times the Sun's mass. The results appear in the January 5th *Science*.

To their surprise, Schneider and colleagues found more massive stars relative to low-mass stars than standard formulas predict. They also real-



▲ Schneider's team studied the bright, central regions of the Tarantula Nebula.

ized that the nebula had given birth to some behemoths: The birth weight of the largest star they observed was equivalent to 200 Suns, notably larger than previous observations, which had suggested that stars aren't born with more than 150 Suns' worth of mass.

It could be that the nebula's conditions allow relatively more massive stars to form. However, to prove that star formation really isn't universal, the team will have to replicate these same methods in other regions, cautions Nathan Bastian (Liverpool John Moores University, UK).

■ MONICA YOUNG

EXOPLANETS

Some Planets Are Bigger Than They Appear

NEARBY STARS CAN MAKE some exoplanet candidates look smaller than they really are, Carl Ziegler (University of North Carolina, Chapel Hill) reported at the American Astronomical Society meeting in Washington, D.C. The results come from the Robo-AO system, which is following up on some 4,000 candidate exoplanets from NASA's Kepler mission. The automated laser-guided adaptive optics system took rapid-fire images of each target star, looking for stellar companions that might muck up the data.

Of 3,857 stars observed with Robo-AO, almost 600 had stellar companions. The extra stars' light contaminated exoplanet transits, making their dips appear smaller and thus giving the impression that the planets themselves are smaller. Generally, having another star in the system makes planets twice as wide as they first appear. Because of this contamination, 8 of the 26 potentially rocky, habitable-zone worlds studied might actually be gaseous. Among them are the confirmed planets Kepler-438b and Kepler-437b, which could be 2 to 3 times larger than estimated if they orbit their system's secondary star.

■ CAMILLE M. CARLISLE

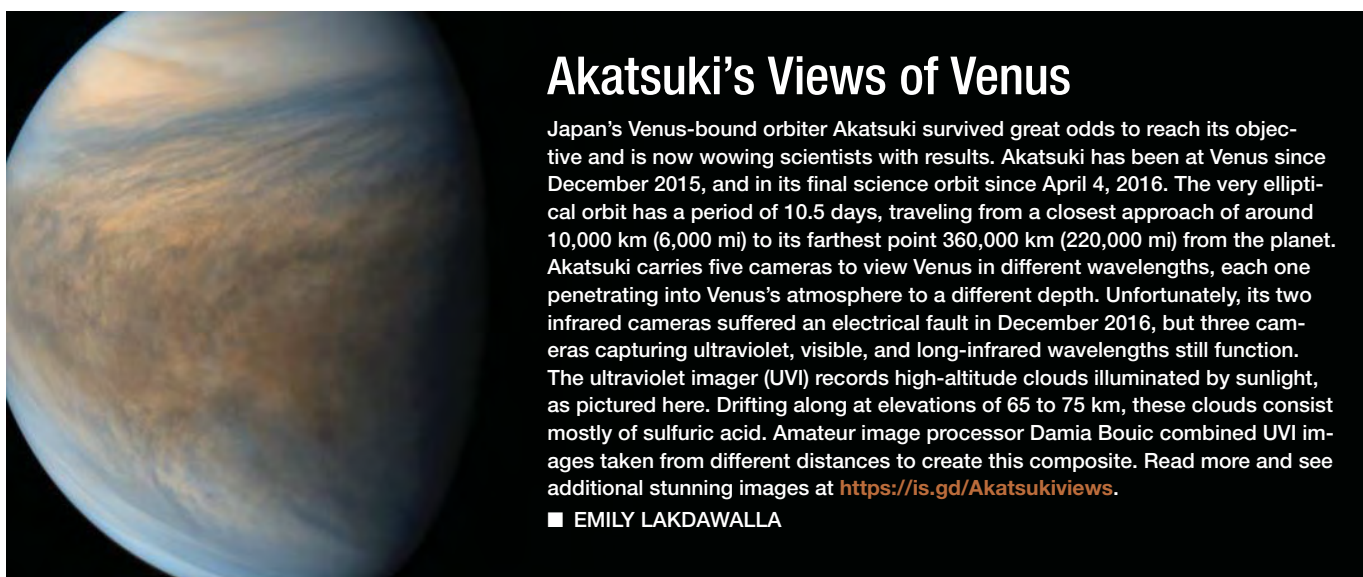

Akatsuki's Views of Venus

Japan's Venus-bound orbiter Akatsuki survived great odds to reach its objective and is now wowing scientists with results. Akatsuki has been at Venus since December 2015, and in its final science orbit since April 4, 2016. The very elliptical orbit has a period of 10.5 days, traveling from a closest approach of around 10,000 km (6,000 mi) to its farthest point 360,000 km (220,000 mi) from the planet. Akatsuki carries five cameras to view Venus in different wavelengths, each one penetrating into Venus's atmosphere to a different depth. Unfortunately, its two infrared cameras suffered an electrical fault in December 2016, but three cameras capturing ultraviolet, visible, and long-infrared wavelengths still function. The ultraviolet imager (UVI) records high-altitude clouds illuminated by sunlight, as pictured here. Drifting along at elevations of 65 to 75 km, these clouds consist mostly of sulfuric acid. Amateur image processor Damia Bouic combined UVI images taken from different distances to create this composite. Read more and see additional stunning images at <https://is.gd/Akatsukiviews>.

■ EMILY LAKDAWALLA

IN BRIEF

Eclipse Created Atmospheric Bow Waves

Although the “Great American Eclipse” is now many months behind us, we’re still learning about the effect of the Moon’s shadow on the *ionosphere*, electrified layers of the atmosphere 80 to 1,000 km (50 to 600 miles) above the ground. Ultraviolet sunlight breaks apart molecules to create these layers, so when the Sun disappears (such as at nighttime), the layers decrease or disappear altogether. Last summer’s eclipse provided the first opportunity to track the effects of the Moon’s shadow as it raced across the continental U.S., as reported in the January 19th *Geophysical Research Letters*. Shunrong Zhang (MIT Haystack Observatory) and colleagues observed the ionosphere using 2,000 GPS receivers across the nation. The receivers communicated with satellites to provide high-resolution data on the total electron content of the ionosphere. Because the Moon’s shadow moved supersonically across Earth’s surface, the disturbances in electron content that it created generated ionospheric bow waves, which were observed most clearly over the central and eastern U.S. Watch the bow waves at <https://is.gd/eclipsebow>.

■ JOE RAO

New Power Source for NASA

NASA has announced the development of a new nuclear generator, one that may become a permanent fixture on lunar outposts or deep-space missions in the coming decades. The Kilopower fission reactor will generate 10 kilowatts of electricity for a minimum of 10 years — more than enough to run several average American households. The new technology offers a more efficient, portable power source that opens new areas for space exploration, such as high latitudes on Mars. Launching nuclear generators into space isn’t without its issues, of course, but tests show that if a Kilopower reactor were lost and the core breached during a launch, the peak dose from exposure to unfissioned uranium for people on the ground would be less than a millirem, and would more likely be in the microrem range, according to Pat McClure (Los Alamos National Laboratory). The average American receives about 620 millirems per year from background radiation. Read more at <https://is.gd/kilopower>.

■ DAVID DICKINSON

MARS

Water Ice Exposed in Martian Cliffs

THICK SHEETS OF water ice, some barely buried beneath the surface and more than 100 meters thick, have been spotted on several Martian cliff faces.

The widely scattered outcrops — seven in the southern hemisphere and one in the north — lie far from the planet’s icy polar caps.

Colin Dundas (U.S. Geological Survey, Flagstaff) led the team that made the discovery using two instruments aboard NASA’s Mars Reconnaissance Orbiter. First, detailed enhanced-color images from the spacecraft’s HIRISE camera revealed bluish layers in the scarps’ steep faces. Then near-infrared maps from the CRISM spectrometer confirmed that the layers are enriched with water ice. The layers appear to persist year-round.

Planetary scientists have realized for more than a decade that vast deposits of water ice must lie just below the planet’s

▼ A thick sheet of underground water ice (blue in this enhanced-color image) lies exposed along a steep slope at latitude 57°S. The ground at the top of the image is about 130 meters higher than the ground at the bottom.

dusty surface. Radar scans from orbit have revealed huge glaciers of ice within 20 meters of the surface over roughly a third of the Martian surface. But these newfound outcrops, reported in the January 12th *Science*, open an unprecedented window into Martian climatic and geologic history.

The team surmises that the icy layers started out as dusty snow or frost laid down over time. The deposits eventually compacted and recrystallized. As exposed ice gradually sublimates, the rocky cliff face crumbles and erodes, revealing fresh exposures of previously buried ice.

The water ice begins within a few meters of the surface and can extend down to more than 100 m (300 ft). Given the planet’s thin atmosphere and temperature swings, geophysicists calculate that water ice on Mars at the scarps’ locations should be stable at depths of as little as 10 cm (4 inches). Being able to access water so easily would be a huge boon to future human exploration of the planet.

■ J. KELLY BEATTY

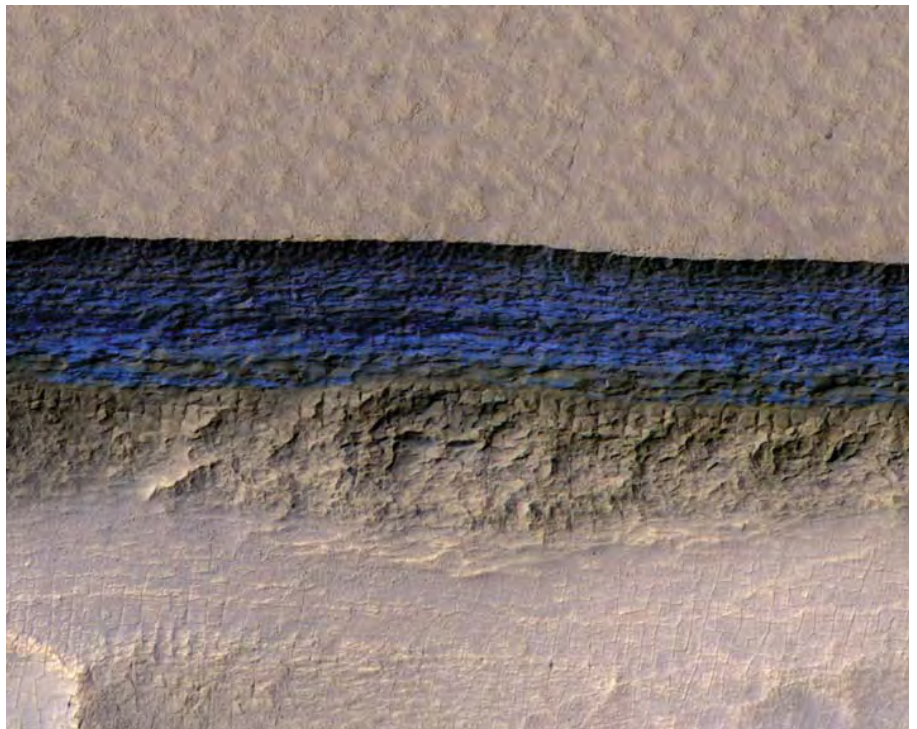

MARS

Gardening on the Red Planet

STUDENTS TAKING PART in the Red Thumbs Mars Garden Project found that, under certain conditions, Martian soil would grow nutritious plants reasonably well, Edward Guinan (Villanova University) announced at the American Astronomical Society meeting in Washington, D.C.

Future Mars colonists will have to grow their own food in order to survive. But the Red Planet's surface receives less than half the sunlight that Earth does, as well as more ultraviolet radiation, and its dirt is more iron-rich, particularly in iron oxides. (It's also rich in poisonous perchlorates, which would

have to be removed before gardening.)

The students planted vegetable and herb seedlings, such as lettuce, kale, garlic, potatoes, and hops, in a simulant that's 90% like Martian soil. Then they monitored the plants' growth in a campus greenhouse, testing various soil additives such as fertilizer.

Mixed greens such as lettuce and kale did well, but potatoes did not. The clay-like Martian simulant was so thick that it crushed the growing taters. Most plants fared better when the students added filler such as coffee grounds to the Martian simulant, which fluffed the dirt up and allowed water to percolate through to the roots.

■ CAMILLE M. CARLISLE

● To read the full story, visit <https://is.gd/marsgardening>.



▲ Villanova students grew garlic, kale, sweet potatoes, hops, lettuce, and other plants in simulated Martian soil.

COSMOLOGY

Orderly Dwarf Galaxies Challenge Cosmological Wisdom

IN THE FEBRUARY 2ND

Science, Oliver Müller (University of Basel, Switzerland) and colleagues report that satellite galaxies are moving around the huge elliptical Centaurus A (NGC 5128) in an orderly fashion. The finding may challenge our understanding of galaxy evolution.



▲ Centaurus A

Current cosmological theory predicts that large galaxies should surround themselves with a chaotic swarm of dwarfs. Instead, out of the 16 Centaurus A satellites with known radial velocities, 14 orbit in the same direction along a broad plane that crosses perpendicular to the galaxy's famous dust band. The result echoes similar findings for our own Milky Way Galaxy, as well as for the Andromeda Galaxy (M31).

Some theorists have proposed that such order might come from gravitational interactions within our Local Group of galaxies. But according to Müller and his coauthors, the likelihood of finding just one example of

coordinated motion among dwarf satellites is smaller than 0.5% in current cosmological simulations. "Finding three such systems in the nearby universe seems extremely unlikely," they write.

However, as Eline Tolstoy (University of Groningen, The Netherlands) points out, "It's still small number statistics." Müller's team could only measure the velocities of the brightest satellites, which could skew the results. Moreover, previous observations have shown that Centaurus A has experienced a major merger in its past, which might have organized its satellites' orbits.

More complete observations of galaxies and their satellite systems can help settle the issue, but the measurements are difficult to make. New data from the European Space Agency's Gaia mission, to be released in late April, should at least clarify the motions of dwarf galaxies around the Milky Way.

■ GOVERT SCHILLING

IN BRIEF

New Definition for Biggest Planets Proposed

Scientists have long set the dividing line between giant planets and brown dwarfs at 13 times Jupiter's mass, the minimum mass required to ignite deuterium fusion in an object's core. However, in the January 20th *Astrophysical Journal*, Kevin Schlaufman (Johns Hopkins University) set a different upper boundary: between 4 and 10 times Jupiter's mass. The new definition is based on how the objects form: Giant planets grow from the bottom up in a process called *core accretion*, so they should form more easily in protoplanetary disks enriched with heavy elements. Brown dwarfs grow from the top down, collapsing directly from a cloud of gas, which doesn't depend so much on heavy elements. Indeed, Schlaufman found that, in 146 carefully selected planetary systems, objects with masses less than 4 to 10 Jupiters tend to form around stars rich with heavy elements, while objects with more than 10 Jupiter masses form around all kinds of stars. These results won't reclassify any planets within our own solar system, but they do have implications for where we draw the line between giant exoplanets and brown dwarfs. Read more at <https://is.gd/planetdefinition>.

■ SHANNON HALL

Chipping Away at Exoplanets

Human ingenuity is helping us unlock the secrets of unimaginably distant worlds.

IT WASN'T LONG AGO that it was astonishing simply to know that planets beyond our own solar system really do exist. Now we know they're everywhere, orbiting nearly every star.

Yet, in a way, exoplanets seem like a cosmic tease. Given their enormous distance and dimness beside the blindingly radiant stars they hug so tightly, it will be hard to learn enough about them to satisfy the profound questions they raise. It's like coming upon a palace full of doorways we can't open, though we know behind them lie clues to the mystery of our existence.

One of the most extraordinary systems we've discovered so far is Trappist-1 (*S&T*: June 2017, p. 12). There, seven roughly Earth-size planets orbit close enough to a dim red star that several may be in the *habitable zone*, with liquid water stable on the surface. Or not. It's awfully hard to say, because what we know is so rudimentary.

We've had only a rough idea of the worlds' masses and diameters. This

It's like coming upon a palace full of doorways we can't open, though we know behind them lie clues to the mystery of our existence.

allowed us to estimate what mix of metal, rock, and ice they're made of. And we know their orbital periods and distances from the star, along with constraints on the ellipticities of their orbits. From this, simple calculations of surface temperature showed that three orbit within the habitable zone. Further

modeling hinted that two of these might have lost all water to a "runaway greenhouse," and the outermost may be frozen over.

Given the little data we have, can we ever determine conditions on these worlds? Recently, planetary geophysicist Amy Barr Mlinar (Planetary Science Institute) and colleagues published some clever modeling they did that factors in the effects of tidal heating. Tidal heating is insignificant among our solar system's inner planets. But it's potent among Jupiter's big moons, which repetitively pull on one another and yank their orbits into very slight ellipses. This non-circular motion leads to enough tidal forcing from Jupiter to melt their insides, creating volcanism on Io and a water ocean inside Europa.

In some ways the Trappist-1 system resembles more a system of Jovian moons than our solar system. These planets torque one another's orbits and tug at each other's insides, depositing heat. Barr Mlinar's results suggested that, because of this heating, two of these Trappist-1 worlds — including one of those previously ruled uninhabitable due to a runaway greenhouse — might indeed support surface liquid-water oceans. Who knows? Maybe something is swimming in those waters.

This study is far from the last word. Barr Mlinar *et al.* described how the great uncertainties in these planets' masses and densities made it hard to reach definitive conclusions.

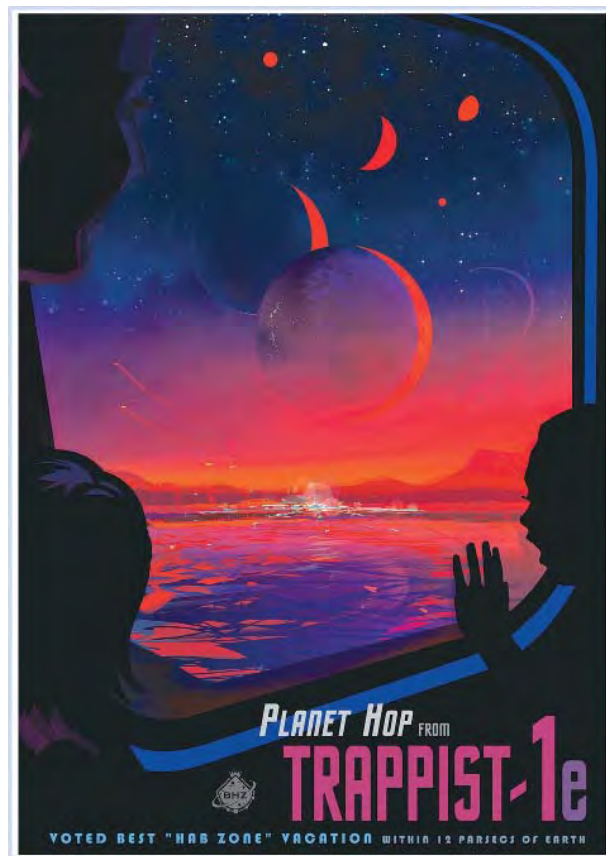

Yet, amazingly, just as this column was going to press, a group of astronomers led by Simon Grimm (University of Bern, Switzerland) reported much more precise masses for these planets, derived by analyzing tiny changes in the timing of transits induced as the planets tweak one another's orbits. Now, geophysicists can apply these improved constraints to their interior models, and we'll get closer to understanding what these planets are really like.

The high-tempo dance between observers and theorists gives me hope that in the coming decades, even without actually going there, we'll make huge strides toward finding out what lies behind all those enticing exoplanet doorways.

■ Astrobiologist **DAVID GRINSPOON** is coauthor with Alan Stern of *Chasing New Horizons*, to be published by Picador this month. Follow him on Twitter @DrFunkySpoon.



37th Annual SAS Conference

Promoting Amateur Science and Amateur-Professional Collaboration



Special Joint Conference with ALPO



June 14-16, 2018
Ontario Airport Hotel
Ontario, California



For further information, please visit our website

www.socastrosci.org

STELLARVUE'S SV152T APOCHROMATIC TRIPLET



HOT
PRODUCT
2018
SKY
& TELESCOPE

SHOWN ON OPTIONAL
PARAMOUNT MYT
&
STELLARVUE TSL10
PIER-TRIPOD

- ✓ AMERICAN CERTIFIED OPTICS
- ✓ HANDCRAFTED IN THE U.S.A.
- ✓ CNC MACHINED MECHANICS
- ✓ LEGENDARY CUSTOMER SERVICE
- ✓ 3.5" FEATHER TOUCH FOCUSER
- ✓ AMERICAN HEAVY DUTY CASE
- ✓ OUTSTANDING FOR VISUAL USE AND/OR PHOTOGRAPHIC IMAGING
- ✓ A PERFECT MATCH FOR OUR TOP-RATED STELLARVUE OPTIMUS 100 - 110 DEGREE EYEPIECES



STELLARVUE®
WWW.STELLARVUE.COM
11820 KEMPER RD.
AUBURN, CA 95603
530.823.7796



THE DARK ENIGMA

Twenty years after they discovered cosmic expansion is accelerating, **astronomers are still working hard to understand why it's happening.**

ENERGY

There's a pervasive force that comprises the bulk of existence, pushing the universe apart faster and faster. Astronomers call it dark energy — a foreboding moniker that itself implies scientists know more about it than they actually do. It's dark because it's mystifying. But no one is sure it's even a type of energy.

The term is simply shorthand for the perplexing, expansive behavior of the universe. Scientists have known the cosmos is expanding ever since Edwin Hubble measured the speed of receding galaxies in 1929 (although some suggest Georges Lemaître should share the credit; *S&T*: Feb. 2012, p. 16). But the rate of expansion, scientists thought, was slowing down, pulled back by the collective gravity of the universe's content.

So when two independent teams of astronomers discovered in 1998 that cosmic expansion was instead speeding up, scientists were shocked. Observers scrambled to collect more data. Theorists were baffled.

Now, 20 years later, what do scientists know about dark energy? Still not a lot. "Our ignorance on this subject is profound," says cosmologist Wendy Freedman (University of Chicago).

But it's not because cosmologists are lazy. Dedicated surveys of the sky have been accruing more data to get a handle on dark energy's properties. Over the next decade, powerful new telescopes promise to reveal clues that may answer some crucial questions. And theorists continue to try to piece it all together.

Ignorance instead persists because dark energy represents one of the deepest mysteries in science. The characteristics of spacetime, the fate of the universe, even the nature of reality itself — dark energy's ramifications reverberate throughout the foundations of physics.

COSMIC RECIPE

Based on the Planck satellite's data, here's how astronomers divvy up the universe among its primary ingredients, in order to produce the cosmos we see.

69%

Dark Energy

The most abundant form of mass-energy. Might be part of space itself. It's accelerating cosmic expansion.

26%

Dark Matter

Massive but invisible, its gravitational influence dictates the formation of cosmic structure.

5%

Baryonic

Stars, planets, astronauts, and everything else in your everyday experience and that you see in your eyepiece.



Einstein Revisited

If astronomers know anything about dark energy, it's that the acceleration it powers is happening. The original, Nobel-Prize-winning discovery relied on comparisons between how bright distant supernovae appear to be with how bright they actually are, based on theories for how such stars explode. These measurements enabled astronomers to determine cosmic distances with newfound precision.

The teams also determined how fast the supernovae's galaxies were receding from us by measuring how much cosmic expansion has stretched, and therefore reddened, the light from its initial wavelengths. When they combined the distance and redshift observations, the teams found that for a given redshift, a galaxy was farther away than they expected it to be — farther, even, than it would be if the universe were totally empty, with no matter to slow down its expansion. Since the universe isn't empty, the result suggested that expansion is actually faster now than in the past.

Other astronomers have since confirmed the observations, measuring more supernovae and other sources with increasing precision. Data from the cosmic microwave background, the afterglow of the Big Bang, also match cosmological models that include dark energy. So do initial results from the Dark Energy Survey, which probes how matter is distributed in the universe and thus how dark energy has wielded influence on cosmic structure over time. The cosmos seems to be ballooning at a greater and greater rate, and it's been doing so for the last several billion years.

Observations do show that the expansion actually did decelerate during the first half of cosmic history, when the universe was smaller and matter and its gravity dominated. But then dark energy took over and has ruled ever since. All the data suggest the acceleration it produces is constant, an intriguing property that traces back directly to Einstein. When applying his theory of general relativity to cosmology, Einstein realized his equations implied the cosmos doesn't stay still. Presumably, due to the attractive pull of matter's gravity, it was shrinking. He deemed that preposterous. So he introduced a term, later dubbed the *cosmological constant*, which represented an antigravity force that countered the

The Expansion Rate

As odd as it sounds, the cosmic expansion rate is not a speed. It's a time scale: the time it takes the universe to double in size. In an accelerating universe, this time shortens as cosmic history moves forward. For example, say a universe doubles its size in 10 billion years. Its next doubling might take only 8 billion years, and the one after that, 5 billion years. That's what we mean by cosmic acceleration.

$$H^2 = \frac{\overbrace{8\pi G}^{\text{Matter density}}}{3} \rho - \frac{\overbrace{kc^2}^{\text{Geometry}}}{a^2} + \frac{\overbrace{\Lambda}^{\text{Dark energy}}}{3}$$

H = Hubble parameter
 c = speed of light
 G = gravitational constant
 ρ = matter density of the universe
 k = curvature of the universe
 Λ = cosmological constant
 a = size of the universe

▲ **THE FRIEDMANN EQUATION** Depending on how you define your terms, there are several ways to write the equation that describes the evolution of the universe, called the Friedmann equation. This version explicitly relates the expansion rate H to the matter density, the universe's geometry (probably flat), and a cosmological constant.

contraction. But it had no real scientific rationale; it was a fudge factor, a mathematical cheat to force his equations to describe the steady, static universe he thought must exist. When Hubble discovered the universe was expanding, Einstein saw no need for the constant anymore.

But the discovery of dark energy revived it. "Until that time, the idea that there was a cosmological constant wasn't something that was particularly viewed with a lot of support in the community," Freedman says. If something were pushing the cosmos apart, then an antigravity force like the cosmological constant — with the opposite effect Einstein envisioned — might fit the bill.

The Energy of Nothing

If cosmic acceleration is constant, dark energy's origins may be spacetime itself. According to quantum mechanics, even a vacuum isn't empty. Virtual particles burst into and out of existence, together generating an ubiquitous *vacuum energy*. The existence of this energy has been confirmed in various experiments, such as in the Casimir effect, in which two uncharged plates in a vacuum still feel a force between them.

According to general relativity, any kind of stuff — matter or energy — bends spacetime. Most things you're used to, like people, planets, and stars, warp spacetime in a way that we experience as gravity. Vacuum energy obeys the same space-curving rule, but it has the opposite effect. This energy is an intrinsic property of space itself, so the expansion of space creates more of it. But you don't get it for free. Creating the energy takes work. The result, it turns out, is that the vacuum energy curves spacetime in a way that's opposite to what normal matter and energy do. That opposite effect manifests itself as antigravity.

As space expands and spawns yet more space, it comes with a proportionate amount of vacuum energy. "If space is empty and you expand it, it's not any more empty than it

used to be — it's still empty," says cosmologist Joshua Frieman (University of Chicago), who serves as director of the ongoing Dark Energy Survey. That means continual expansion does not dilute vacuum energy: It has a constant density. And constant density means a constant rate of cosmic acceleration.

To describe dark energy, cosmologists use a number called w , which is the ratio of its pressure to its energy density. For a cosmological constant, the energy density doesn't change as the universe expands, and so w is precisely -1 . Experiments like the Dark Energy Survey, using its dedicated camera on the Victor M. Blanco 4-meter telescope at the Cerro Tololo Inter-American Observatory in Chile, have indeed measured w to be about -1 .

In a way, the cosmological constant is straightforward. It's consistent with observations and seems simple enough, which may be why many cosmologists cite it as the most reasonable explanation for dark energy. But another appeal is that underneath the simplicity, the cosmological constant might hint at physics both profound and radical.

Deep Questions

For decades, physicists have grappled with why the cosmological constant has the value it does. By measuring cosmic expansion, researchers have found the constant to be quite small — around 10^{-10} erg/cm³ — but that doesn't jive with quantum physics. The current equations of quantum physics give a sense of how big the constant should be. Those calculations yield a constant that's 120 orders of magnitude larger than what's measured. Even tweaking the equations, physicists can't lower the discrepancy by more than about 60 orders of magnitude. The tiny value of the cosmological constant seems to be unmoored from any theoretical anchor.

One way around this difference, though, evokes the controversial concepts of the multiverse (*S&T*: Dec. 2012, p. 20). The idea, first proposed by Steven Weinberg in the 1980s, posits the existence of a vast number of possible universes, each with its own unique type of empty space and corresponding value of the cosmological constant. Our universe simply has the value that gives rise to galaxies, stars, planets, and astronomers who can measure it.

SPACETIME FABRIC On cosmic scales, all points in the universe (represented by the grid) are moving farther away from one another. This effect is due not to galaxies streaming through stationary space but to space itself expanding, which means the size of the grid squares themselves is growing. As a result, any two points fixed on the grid move away from each other with a relative speed that's proportional to the distance between them. (The illustration uses a central point for clarity of presentation, but there's no center to cosmic expansion.)



The multiverse also aligns with string theory — the best candidate yet for a quantum theory of gravity, a.k.a. a theory of everything — which suggests a multitude of separate, coexisting universes might exist, of which our universe is one.

Whether string theory and the multiverse are true or not, dark energy seems to be intimately intertwined with the fundamental nature of reality. “It’s hard to separate it from really exciting, deep questions,” says physicist Andreas Albrecht (University of California, Davis).

A Big Rip, New Fields, and a Can of Worms

Of course, dark energy might be something completely different. So far, none of the data is precise enough to rule out all alternatives. The Dark Energy Survey, for example, has measured w to be -1.00 , but with an uncertainty range of -1.05 to -0.96 , and statistically, there’s about a 30% chance that the real value could lie outside this range. Deviations from -1 would mean dark energy is not the cosmological constant, and the acceleration changes with time.

“If w is observed to be different from -1 , it’ll wreck some huge fraction of theories,” Albrecht says. A w more negative than -1 may send the universe on an ever-expanding, suicidal path called the big rip, eventually tearing apart even atomic nuclei. A larger w means the rate of acceleration slows down.

The Dark Energy Survey’s measurement of w also comes with a big caveat: The researchers had to assume that w stays the same value throughout cosmic past, present, and future.

If w varies over cosmic history, then the way the acceleration changes with time also changes with time. The acceleration might sometimes speed up and other times slow down.

If cosmic acceleration changes over time, then dark energy may be some new kind of dynamic force similar to the one hypothesized to have driven the brief period of inflation, when the universe experienced an exponential growth spurt soon after the Big Bang.

From a theorist’s perspective, such a force, sometimes called *quintessence*, would be less disruptive to physics than the cosmological constant would, Albrecht says. That’s because quintessence is what’s called a *scalar field*, a function that has a particular value at each point in space, as temperature does. Scalar fields are nothing new to physicists.

“More importantly,” Albrecht says, “adding another field does not seem to be a path to addressing deep questions.” Adding a cosmological constant, on the other hand, would require adding a new, fundamental aspect of physics.

There’s yet another possibility to explain dark energy. Maybe the acceleration isn’t due to any vacuum energy or force of any kind, but a result of an incorrect understanding of gravity. Maybe Einstein’s masterwork for describing gravity, the general theory of relativity, behaves differently at cosmic scales, producing what’s observed as cosmic acceleration.

“That’s a huge can of worms,” says cosmologist Mark Trodden (University of Pennsylvania). General relativity has proven to be tight and robust. “It’s very beautiful, and when you play

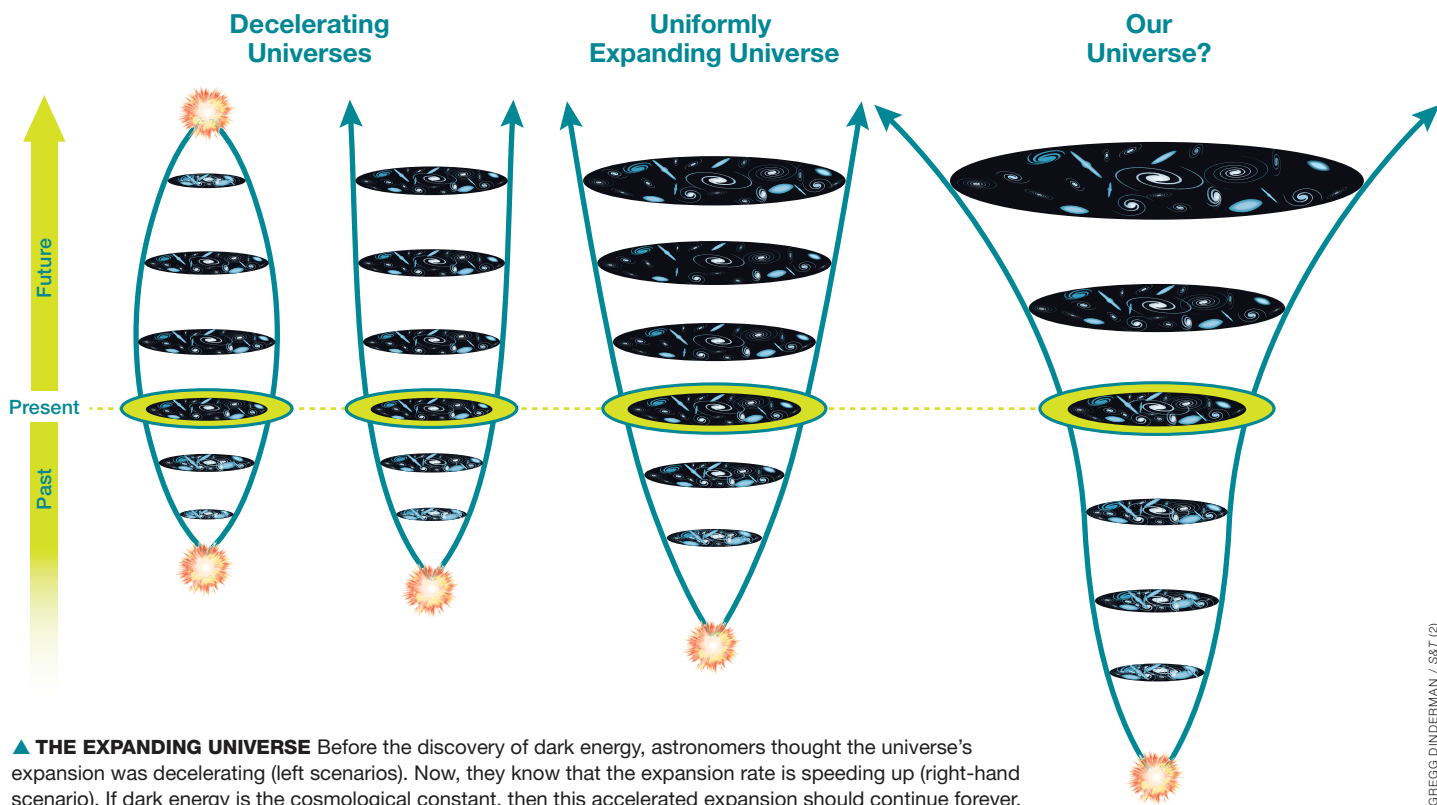

▲ **THE EXPANDING UNIVERSE** Before the discovery of dark energy, astronomers thought the universe’s expansion was decelerating (left scenarios). Now, they know that the expansion rate is speeding up (right-hand scenario). If dark energy is the cosmological constant, then this accelerated expansion should continue forever.

GREGG DINDERMAN / S&T (2)

with it in any number of ways, you ruin the theory,” he says. “It’s very hard to modify gravity and get a sensible theory.”

Exploring the Darkness

Final judgment on any of these ideas will depend on what current and future telescopes see. Cosmologists are after two main things. The first is a more accurate measurement of the current expansion rate, which is somewhat contested (see page 20). Astronomers can achieve that with better observations of things such as supernovae and neutron star collisions.

But they’re also measuring primordial sound waves called *baryon acoustic oscillations* (S&T: Apr. 2016, p. 22). These waves were born not long after the Big Bang, when the universe was a hot plasma soup. Fluctuations in the density of the plasma generated sound waves that rang throughout the young universe. But when the cosmos cooled and atoms formed, the sound waves were silenced, their periodic patterns frozen in the cosmic microwave background. As the universe continued to expand, those patterns grew, imprinting themselves in the distribution of galaxies.

Like supernovae, these wave patterns act as a cosmic yardstick. By comparing the apparent size of the patterns with how big theory predicts they should be, cosmologists can determine how far away they really are. Researchers can then use these distances to piece together the universe’s expansion history.

The second thing cosmologists want to know is how cosmic structure — the distribution of matter in the universe — evolved over time. “The pattern of large-scale structure tells us about this kind of cosmic tug-of-war

between gravity, which is trying to pull galaxies together, and dark energy, which has been pushing them apart,” Frieman says.

One way to study cosmic structure is to analyze how galaxy clusters are scattered across the sky. Another method involves the nearly imperceptible distortions of galactic images caused by dark matter, an effect called *weak gravitational lensing*. By measuring how dark matter’s gravity bends the light from galaxies, researchers can map the dark matter — the main component of cosmic structure — throughout cosmic history.

Having these two strategies of measuring cosmic expansion and structure growth is vital, as the dual approaches offer independent tests of modified gravity. “Gravity affects the expansion rate of the universe and the growth of cosmic structure differently,” says cosmologist Rachel Mandelbaum (Carnegie Mellon University). Comparing measurements of expansion and structure growth will reveal whether dark energy is real, or if general relativity needs to be changed.

A Wide Open Field

In 2005, a team of researchers formed the Dark Energy Task Force to outline how, as a field, researchers would tackle the

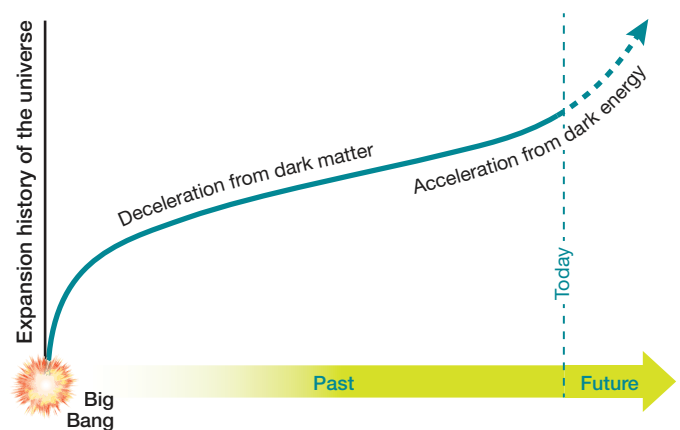

▲ **INCONSTANT UNIVERSE** As astronomers have pushed their distance ladder farther back in time, they’ve discovered that the expansion rate did slow — just not permanently. Matter’s gravity decelerated the expansion during the first half or so of cosmic history, then dark energy took over. This behavior would make sense if dark energy were the cosmological constant: Since expanding space produces more vacuum energy, the cosmic balance would ultimately hit a tipping point, after which the vacuum energy’s antigravity effect overpowers matter’s gravity.

herculean challenge of solving dark energy. They established that a combination of at least two of the four primary techniques — supernovae, baryon acoustic oscillations, galaxy clustering, and weak lensing — is necessary to tease out the properties of dark energy. They set goals of homing in on a

value for w . They laid out what types of telescopes and surveys would be needed. And they calculated a so-called figure of merit to quantify how much a progressive sequence of experiments would have to improve in precision. “We made these recommendations, and they’re pretty much all coming to pass,” says Albrecht, who was on the original team along with Freedman.

Numerous telescopes are now scanning the skies for clues about dark energy. The Dark Energy Survey, which began in 2013, is now in its last year, but it has collected so much data that last summer’s results only pulled from the first year of observations. Those initial results included lensing and clustering data. The first big data release, made in January 2018, included three years of observations of several hundred million galaxies spread over one-eighth of the sky. The collaboration is now analyzing those data to measure large-scale structure and lensing effects.

The task force’s final recommendations included additional large-scale surveys to probe dark energy with unprecedented precision. Those, too, may come to pass. In the early 2020s, the European Space Agency plans to launch the Euclid space telescope to analyze patterns in the distribution

“The pattern of large-scale structure tells us about this kind of cosmic tug-of-war between gravity, which is trying to pull galaxies together, and dark energy, which has been pushing them apart,” Frieman says.

How Fast Is the Universe Expanding?

There's some scientific ado of late over a conflict in measurements of the universe's expansion rate. The present rate is called the Hubble constant, or H_0 (pronounced "H-naught"), and it connects the redshift of an object's spectrum to its physical distance. It also encodes the universe's age and size.

Broadly speaking, astronomers calculate the expansion rate from two directions: starting now and looking back in time, or starting at the beginning of cosmic history and working forward. The first approach uses measurements of things such as supernovae and Cepheids to peg redshifts to distances and build a precise distance ladder farther and farther out. The second, predictive approach uses imprints of the primordial universe's properties in the cosmic microwave background (CMB) or the distribution of galaxy clusters and other matter and propagates them forward in time.

As these calculations become more precise, astronomers are noticing an odd trend: The first tack favors an expansion rate that is higher than that from the second one (see graph). If we take the numbers at face value, then today's universe appears to be expanding about 9% faster than we expect it to, dark energy codiscoverer Adam Riess

(Johns Hopkins University) said January 9th at the 2018 American Astronomical Society winter meeting in Washington, D.C.

The discrepancy has spurred speculation about whether we're on the verge of discovering something new about the physics of the universe. But a warning: This bifurcation might not pan out. There's still plenty of possibility that the range in values is a byproduct of how astronomers crunch the numbers. Scientists don't even agree on how likely it is, statistically speaking, that the spread in H_0 values is real. Despite the media attention, many astronomers don't think it'll prove legit.

The resolution to the controversy will come from pushing H_0 measurements to be as precise as possible. From the primordial end, the Planck team plans to release its final analysis soon, and the Dark Energy Survey group is working away on its own data. From the other end, astronomers are awaiting the Gaia mission's parallax measurements, which will stabilize the distance ladder.

To keep things interesting, News Editor Monica Young and I have placed a bet on whether the H_0 discrepancy is real. We plan to call the winner after Gaia's full data set comes out around 2022.

—Camille M. Carlisle

Hubble Constant Measurements

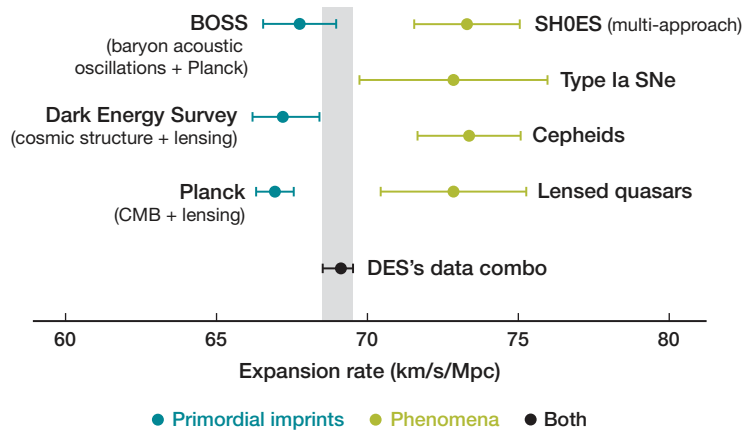

▲ **IS THERE A PROBLEM HERE?** Many astronomers working very carefully have calculated the universe's current expansion rate, but although the values are similar they don't quite agree (representative examples shown). Changes to our cosmological recipe could reconcile the split in values, or further work might obviate it.

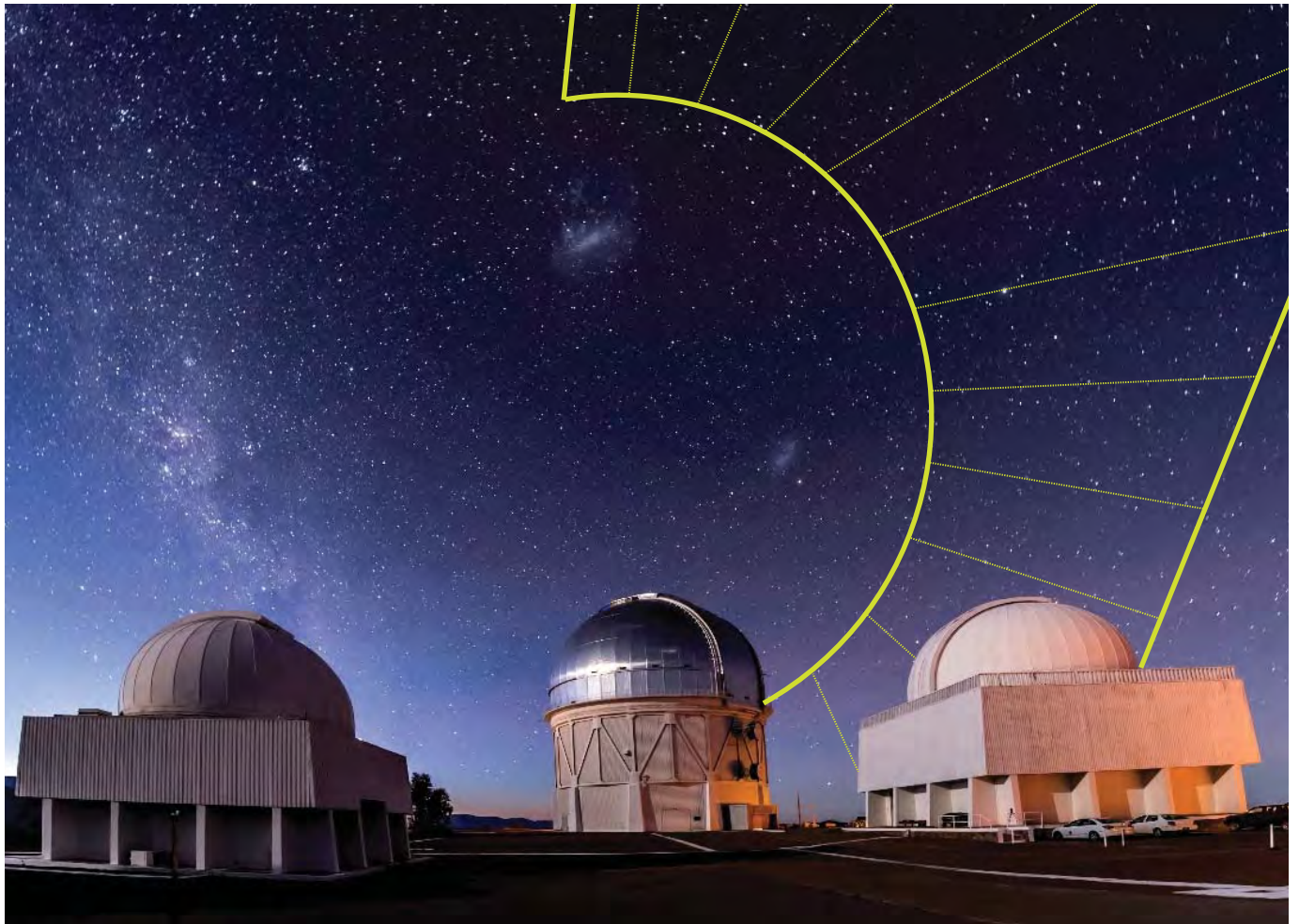

and distorted images of galaxies. NASA's Wide Field Infrared Survey Telescope (WFIRST) is slated to launch soon after to combine its own, similar observations with supernovae, but its funding is in jeopardy. The Large Synoptic Survey Telescope (LSST), anticipated to begin operating in 2023 from Chile, will study dark energy using all four techniques.

With the flood of new and improved data, cosmologists anticipate they will finally be able to answer some of the most basic questions about dark energy. Is it truly the cosmological constant with $w = -1$? Does w change over time?

But measuring w is just the beginning. A single number like w can't encapsulate the complexity of dark energy and these large-scale observations. Even with a precise value of w in hand, cosmologists won't have dark energy totally figured out. "What you really care about is the rich detail that comes out of these surveys," Trodden says. " w is a useful placeholder. It's a useful shorthand for talking about some features of dark energy, but depending on what dark energy is, there could be a lot more to it."

And there's the rub. At this point, despite a well-defined observational strategy, dark energy can be almost anything. While theorists trying to understand it have learned a lot about the subtleties of gravity and particle physics, they haven't come to a consensus, Trodden says. Whether it's the cosmological constant, quintessence, modified gravity, a combination of these, or anything in between, the field of theories remains wide open.

▲ **SURVEY ON THE SKY** Over five years the Dark Energy Survey, working at the Blanco telescope on Cerro Tololo in Chile, is mapping several hundred million galaxies, as well as other cosmic expansion signposts, to clarify the nature of dark energy. In yellow is roughly half of its 5,000-square-degree footprint on the Southern Hemisphere sky.

Although future observations will almost certainly make important discoveries that guide theorists, don't expect any conclusive answers right away. In fact, Albrecht says, regardless of what next-generation telescopes like LSST find, it's hard to imagine that current theories will adequately explain the data. "Our theoretical picture feels incomplete," he says.

Yet, being the scientists they are, cosmologists — and especially theorists like Albrecht and Trodden — embrace this ignorance. Dark energy is a hard problem, and taking the long view is required. "It's one of the deepest things about the universe we've ever learned, and we've only known it for 20 years," Trodden says.

The pursuit of dark energy demands an oxymoronic mixture of hubris and humility, a balance between deference to nature's mysteries and the confidence to conquer them. "I hope that I'm the one who figures out how to understand it," Albrecht says, before adding a second point: "I'm skeptical anyone will do that in my lifetime."

■ **MARCUS WOO** is a freelance science journalist based in the San Francisco Bay Area.

Big, Bold, Br *and Bea*

Pick some low-hanging fruit tonight.

The average amateur astronomer goes through several phases of development. There's the novice phase, when we're just learning our way around the sky (and our equipment). There's the intermediate phase, when we begin hunting for more and more difficult objects in order to stretch our abilities and test our limits. There's the photographic phase, wherein we drop down the rabbit hole of equipment, equipment, and more equipment in order to document every beautiful nook and cranny in the sky (and seldom look through an eyepiece anymore). There's the deep-sky-hunter phase, during which we don't just push our limits but shove them around and bully them into submission. And there's the tourist phase, when we once again spend time with the big, bold, bright, and beautiful objects that led us



KEN CRAWFORD



ight, *utiful*

SPRINGTIME TREATS Just because you've observed them before doesn't mean you should file them away: Spend some time this spring revisiting old friends. Or perhaps even making new acquaintances. Like NGC 4565 seen here.

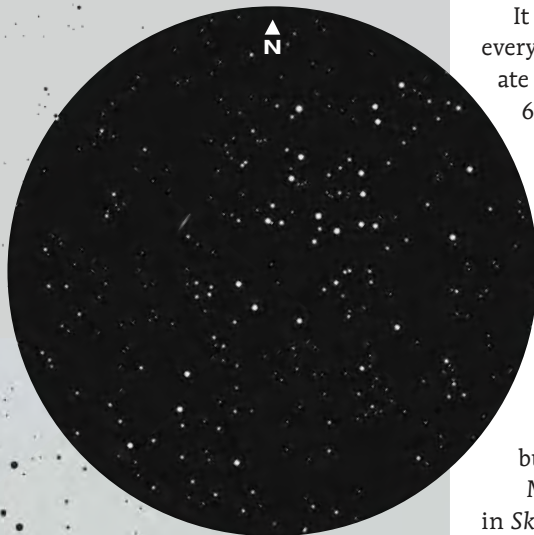

▲▲ **THE WHALE AND THE HOCKEY STICK** The Whale Galaxy is one of the best galaxies in Canes Venatici. The Hockey Stick is dimmer but nevertheless cool if you have some aperture and dark sky.

▲ **A TWINKLING OF STARS** Melotte 111 is often called Coma Berenices, even though the constellation is larger than just the cluster.

◀ **THE NEEDLE GALAXY NGC 4565** is an edge-on spiral, the appearance of which gives it its common name.

into the hobby in the first place. We call that the “eye candy,” the stuff we show off at star parties when we want to make people go “Oooohh!”

The phases aren’t necessarily a progression. You can run them in just about any sequence and even do them simultaneously. I’ve always been a tourist, visiting many showcase objects in an evening even when I’m actually on a mission to find a Hickson galaxy group. Lately, however, I’ve found myself reverting to tourist mode more and more, just kicking back and enjoying the view rather than pushing myself to examine yet another faint fuzzy for detail that’s visible only via “averted imagination.”

This article, and the occasional follow-up in future issues, is for the tourist. It’ll also be useful for beginners who haven’t yet learned the objects herein. I’m writing it for the person who either hasn’t seen everything that’s easily visible yet or has seen so many objects he or she can barely remember which ones are easy and which ones are hard. It’s a list of my favorites, written partially so I can remember them myself.

It should be a pretty good asset at a star party. Just about everything I feature should be visible through at least moderate light pollution, with modest-aperture telescopes (say 6-inch or greater), with many objects visible in smaller scopes or even binoculars. If you happen to have a 20-inch monster, though, most of these objects will be jaw-droppingly stunning. Seriously. You haven’t lived until you’ve turned a big scope on the Andromeda Galaxy or the Pleiades. But you don’t need a big scope to enjoy the objects I list here. They’re big, bold, bright, and beautiful on their own.

My criterion for inclusion is simply this: Will an object reward people who look for it with a “wow” moment? Not every object will have all four of the Bs, but they’ll probably have at least three of them.

Most, if not all, of the objects I write about will be listed in *Sky & Telescope’s Pocket Sky Atlas*. That has to be one of the most useful and ubiquitous atlases out there, and I don’t say that just because I write for the magazine. I had three

copies before S&T hired me to write *Astronomer’s Workbench* (one for the study, one for the field, and the jumbo version for my aging eyes).

I’ve illustrated several of the objects with sketches. Why sketches? Because photographs don’t show what you’re likely to see through an eyepiece. They can lead to unreal expectations and disappointment. My sketches are a bit optimistic, too, so they will reproduce well in the magazine, but they’re closer to reality than photographs. (Yes, it’s ironic, isn’t it?)

So without further ado, let's explore some of the Big, Bold, Bright, and Beautiful objects in the spring sky.

Let's start in the north. All the way north, in fact.

Polaris, Alpha (α) Ursae Majoris, is the North Star, around which all the other stars in the sky appear to revolve. That in itself would make it worth looking at, for the concept if nothing else, but Polaris is intrinsically interesting and would be worth a look no matter where in the sky it might be. Why? Because it's a double star. And it's not just any old double; it's a wildly unequal double, with a primary of magnitude 2.0 and a secondary of magnitude 9.0. Each magnitude of difference is about 2.5 times brighter than the next, so that means the primary is 2.5 to the 7th power (their difference in magnitude) or 610 times brighter than the secondary.

Brightness differences that extreme normally make the secondary star hard to see. (We talk about doubles being "hard to split" if their separate components are difficult to distinguish.) Fortunately Polaris's companion lies 19" away, which is far enough to let the secondary stand out beyond the primary's glare, yet close enough to make the pair interesting. You should be able to see it with a good 3-inch or larger telescope. If not, it might be masked by a diffraction spike. Try rotating the scope or waiting a few hours. Polaris will still be right where you left it.

The secondary is an actual companion, albeit a distant one. Its true separation has been estimated at 2,400 astronomical units from the primary and its period at 42,000 years. It will be a long time before you notice any movement.

Skipping over the various Messier objects in Ursa Major (although you would be foolish to do so on a tourist outing), I'll move on to the star Y Canum Venaticorum, known as **La Superba**. It's inside the curve of the Big Dipper's handle, right about where the point of your compass would go if you were to extend the handle around in a circle. La Superba is a carbon star, which means it's one of the deepest red stars in the sky. At an average magnitude of 5.3 you can see it directly under dark sky, but you probably won't notice its color until you look at it through binoculars or a telescope. When you collect enough light, you'll trigger your color vision and suddenly you're looking at a glowing barbecue coal.

Seriously, that's about what you're looking at. Carbon stars are so cool that carbon soot collects in their atmospheres and scatters most of the blue light, leaving only the red charcoal glow to escape the photosphere and travel to your eye.

Like many carbon stars, La Superba is variable, ranging from 4.8 to 6.4 with a period of about 157 days. The intensity of its color changes with its overall brightness, so check this one often and see if you can figure out when it's brightest, and when it's reddest.

Where to Find the Big, Bold, Bright, and Beautiful

Object	Designation	Type	Surface Brightness	Mag(v)	Size/Sep	RA	Dec.
Polaris	Alpha UMi	Double star	—	2.0, 9.0	—	02 ^h 31.8 ^m	89° 16'
La Superba	Y CVn	Carbon star	—	4.9	—	12 ^h 45.1 ^m	45° 26'
Whale Galaxy	NGC 4631	Galaxy	12.8	9.2	12.8' × 2.4'	12 ^h 42.1 ^m	32° 32'
Hockey Stick	NGC 4656	Galaxy	13.5	10.5	10.0' × 1.8'	12 ^h 43.9 ^m	32° 09'
	NGC 4657	Galaxy	10.5	10.9	1.3' × 0.6'	12 ^h 44.2 ^m	32° 12'
Melotte 111		Open cluster	—	1.8	300'	12 ^h 25.1 ^m	26° 07'
Needle Galaxy	NGC 4565	Galaxy	13.2	9.6	15.8' × 2.1'	12 ^h 36.4 ^m	25° 59'
Lalande 21185		Red dwarf star	—	7.5	—	11 ^h 03.3 ^m	35° 58'
Leo Triplet	M65	Galaxy	12.8	9.3	9.8' × 2.9'	11 ^h 18.9 ^m	13° 06'
	M66	Galaxy	12.7	8.9	9.1' × 4.2'	11 ^h 20.3 ^m	12° 59'
	NGC 3628	Galaxy	13.4	9.5	14.8' × 3.0'	11 ^h 20.3 ^m	13° 35'
M95		Galaxy	13.5	9.7	7.4' × 5.0'	10 ^h 44.0 ^m	11° 42'
M96		Galaxy	13.1	9.3	7.6' × 5.2'	10 ^h 46.8 ^m	11° 49'
M105		Galaxy	12.8	9.3	5.4' × 4.8'	10 ^h 47.8 ^m	12° 35'
NGC 3384		Galaxy	12.6	9.9	5.5' × 2.5'	10 ^h 48.3 ^m	12° 38'
NGC 3389		Galaxy	13.2	11.9	2.8' × 1.3'	10 ^h 48.5 ^m	12° 32'
Rinnan's Run		Asterism	—	6.1–13+	—	10 ^h 46.5 ^m	3° 20'

Angular sizes and separations are from recent catalogs. Visually, an object's size is often smaller than the cataloged value and varies according to the aperture and magnification of the viewing instrument. Right ascension and declination are for equinox 2000.0.

From La Superba, skipping over Cor Caroli (which you shouldn't, because it's another nice double star) takes you to the **Whale Galaxy**, NGC 4631. It's not marked as anything special in the *Pocket Sky Atlas*, but it's one of the more interesting galaxies in the area. One look will reveal why: It's relatively bright at 9th magnitude, and it's thicker on one end than the other. It does, in fact, look a lot like a whale swimming along through the ocean of night. It's fairly big, too, extending 15' (half a Moon diameter) from end to end. There's a smaller elliptical galaxy just to the north of it (NGC 4627), which some people call "The Calf," but to me it looks like a puff of steam from the whale's blow hole drifting back over its body as it swims along to the east. You'll need some aperture and dark sky to see the steam puff.

To the southeast of the Whale about ½° you might find the **Hockey Stick** if you have dark enough sky and a large enough scope. It's two galaxies (NGC 4656 and NGC 4657) that join together in what looks remarkably like a hockey stick. The main part of the stick is magnitude 10.5 and the blade is 12.4, so this isn't exactly B3 as far as Big, Bold, Bright, and Beautiful goes, but it's a frequent side-stop when visiting the Whale. At low power they'll both fit in the same field of view.

About 6° south of the Whale and Hockey Stick you'll see a large, naked-eye dusting of stars that's the most prominent feature in Coma Berenices. In fact, most people call the cluster Coma Berenices and forget there's more to the constellation. The cluster itself is cataloged as **Melotte 111**, and it's stunning in binoculars, with dozens of stars ranging from 4th to 10th magnitude in a field about 5° wide. The cluster looks lopsided to me, with most of its stars to the west of an obvious vertical dividing line. At 288 light-years, it's the third-closest star cluster to us, after the Ursa Major Moving Group and the Hyades.

It's unreal.
 How could such
 a thing form?
 Is it random chance?
 Leo sharpening his
 claws? I have no idea.

Melotte 111 is too big for a telescope, so let's have a look at a big, bold, bright, and beautiful telescopic object within it. The **Needle Galaxy**, NGC 4565, fits the bill perfectly. This is one of the finest galaxies of spring and summer. It's an edge-on spiral, and it's big (also half a Moon diameter) and bright enough that you can easily see the dark lane cutting across its core and disk. The galaxy is tilted just enough that the core peeks over the dust lane, so it looks like a bright star right there at the center. This is one of those objects that just gets better and better the more aperture you throw at it.

Off to the northwest a little more than 20° lies **Lalande 21185**, a red dwarf star that's remarkable for two reasons: It's the fourth-closest star to the Sun, after the Alpha Centauri system, Barnard's Star, and Wolf 359; and it's the brightest red dwarf in the northern hemisphere. At magnitude 7.5 it's easily visible in any scope or binoculars, and it's noticeably red (although not as red as a carbon star!).

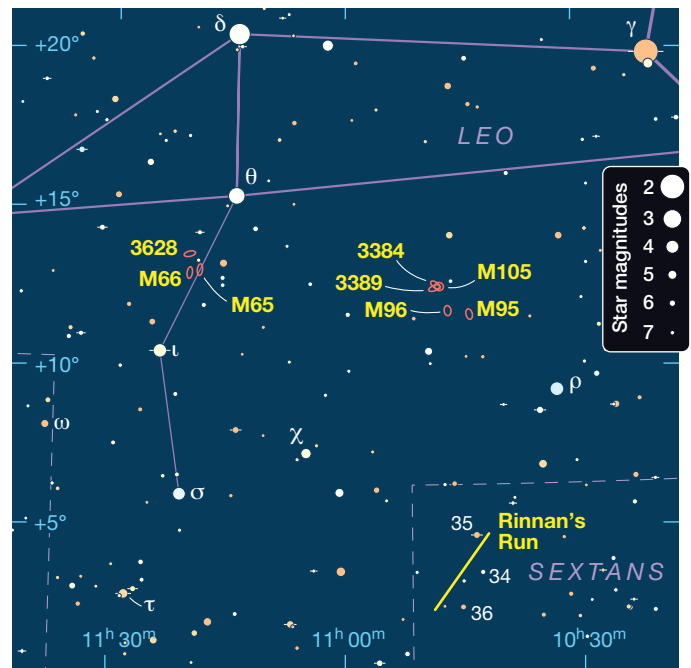
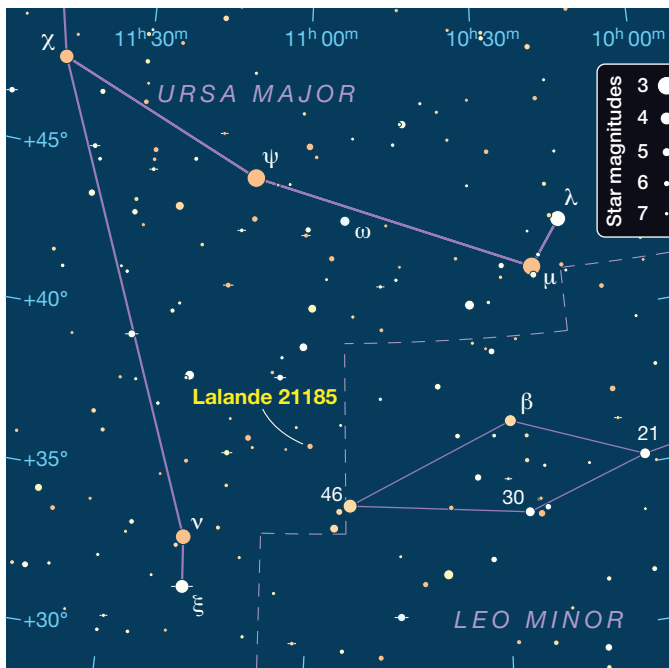

I'm running out of space already so let's jump to some serious eye candy for our grand finale. How about a triplet of galaxy triplets? No, you can't see them all in the same field, but two fields will do.

The first is the famous **Leo Triplet** under the hindquarters of Leo, the Lion. Comprised of M65, M66, and NGC 3628, it's one of the most spectacular galaxy groups in the sky. All three galaxies are near 9th magnitude, and they fit comfortably within the view of a 1° true-field-of-view (TFOV) eyepiece. They're all spirals seen at varying degrees of tilt, with NGC 3628 being nearly edge on to us, showing some interesting dust lanes. They're well worth studying each one at high power when you get tired of looking at them all in one field.

The next triplet is under Leo's belly, and it's all Messier objects: **M95**, **M96**, and **M105**. M95 and M96 are spirals, while M105 is a bright elliptical. They're spread out a little more than the previous triplet, so you'll need about a 1½° TFOV to see them all at once.

When you're ready to zoom in, though, zoom in on M105. To the northeast, only a couple of galaxy diameters away, you'll find **NGC 3384**, just half a magnitude fainter. Then look to the southeast about the same distance and use averted vision. With some aperture and dark sky, you'll see 12th-magnitude **NGC 3389**, making up a triplet within a triplet.

Okay, that last one wasn't exactly Big, Bold, nor Bright (although I do hope you'll find it Beautiful nonetheless). So here's a sight that's all four Bs. In fact, like Melotte 111, it's so big you'll need binoculars; a telescope won't do. Start at 35 Sextantis, down beneath the belly of Leo, and follow a long chain of stars south-south-east for a full 3°. The top end has two nice binocular doubles (one component of which, 35 Sextantis, is a nice telescopic double), and the bottom packs the stars in tighter and tighter. It's such an obvious line that it looks like a rip in the fabric of space. The closer you look, the more stars you see in the line. It's unreal. How could such a thing form? Is it random chance? Evidence of a cosmic string? Leo sharpening his claws? I have no idea. This cascade of stars is called **Rinnan's Run**, after Oregon amateur Dan Rinnan, who found it in his binoculars one night in 2010.

I hope you've enjoyed this taste of the low-hanging fruit of the night. We often overlook the obvious while going for something deeper in the tree. Next time you're out, remember the bright stuff!

■ **JERRY OLTION** loves playing tourist with just about any telescope. Contact Jerry at j.oltion@gmail.com.

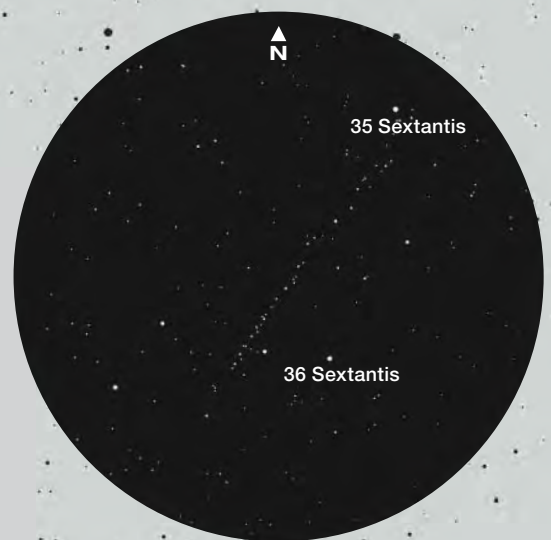
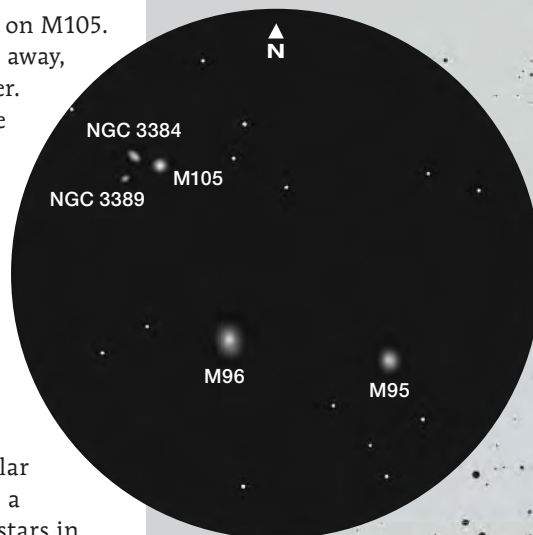
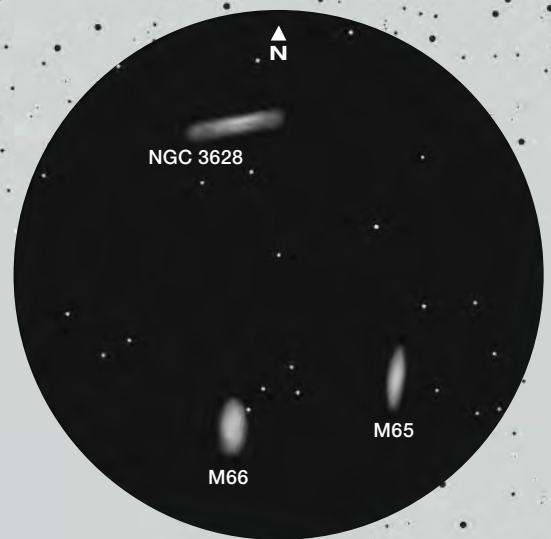

▲ **TRIPLETS IN THE LION** The more famous of the Leo trios lies under the hindquarters of the lion.

▲ **A TRIPLET WITHIN A TRIPLET** The galaxy triplet under Leo's belly contains a second triplet around M105.

▶ **A STREAM OF STARS** Rinnan's Run is a long chain of stars below the triplets in Leo discovered by Oregon amateur Dan Rinnan.

DIG

into NASA's Planetary Data System

A vast treasure trove of unseen planetary images awaits intrepid amateurs.



Deep in the cold, black void of space, a spaceship spied the unblinking light of its destination. The ship collected the light, split it into its component wavelengths, and measured its brightness. It sent those measurements back to Earth, to a team of scientists and engineers who delighted in the scientific bounty of the ship's data. The scientists and engineers had worked hard to gather that data, but their work had been made possible by the support of their countries' taxpaying public. So, after checking to make very sure that the data were of the highest possible quality, the scientists shared the vessel's hard-won data with the world.

Since 1989, NASA has provided open access to all its science missions' data through the Planetary Data System, or PDS. For many years, the PDS even served as the primary distributor for non-NASA planetary data. Initially designed for use by researchers, the PDS has historically been difficult to

approach by the broader public. Yet a few intrepid enthusiasts have climbed to the top of the learning curve to discover and share beautiful but rarely seen images from space.

In the 21st century, the PDS has begun to make itself more accessible to anyone who has internet access and curiosity about what lies within the archives. A rich treasury of beautiful images awaits anyone who cares to explore.

Nodes of the PDS

Before the PDS, NASA missions distributed data to investigators in (typically) hard-copy form, which limited its reach beyond the mission science teams. In the

◀ **PDS ENTRY** When first entering the PDS, you need to specify what type of user you are. Amateur data-miners (or "citizen scientists") should first select Data Consumer (top), then Students and Educators (including Citizen Scientists). Once completed, a helpful guide opens to quickly get you to several locations.

Welcome to the PDS Resource Catalog!
This tool will help guide you to the proper set of PDS resources.

First thing, what type of user are you?

Data Provider Data Consumer

DO NOT SHOW THIS AGAIN

Curiosity Home | Data Consumer

Thanks! Now what type of data consumer are you?

Students and Educators (including Citizen Scientists) Researchers

Related Items | Curiosity Home | Students and Educators

OK. Here are some commonly-used data consumer resources that may help you.

Introduction PDS Resources Near Curiosity Photo Gallery

Map of Planet Data Search Tools

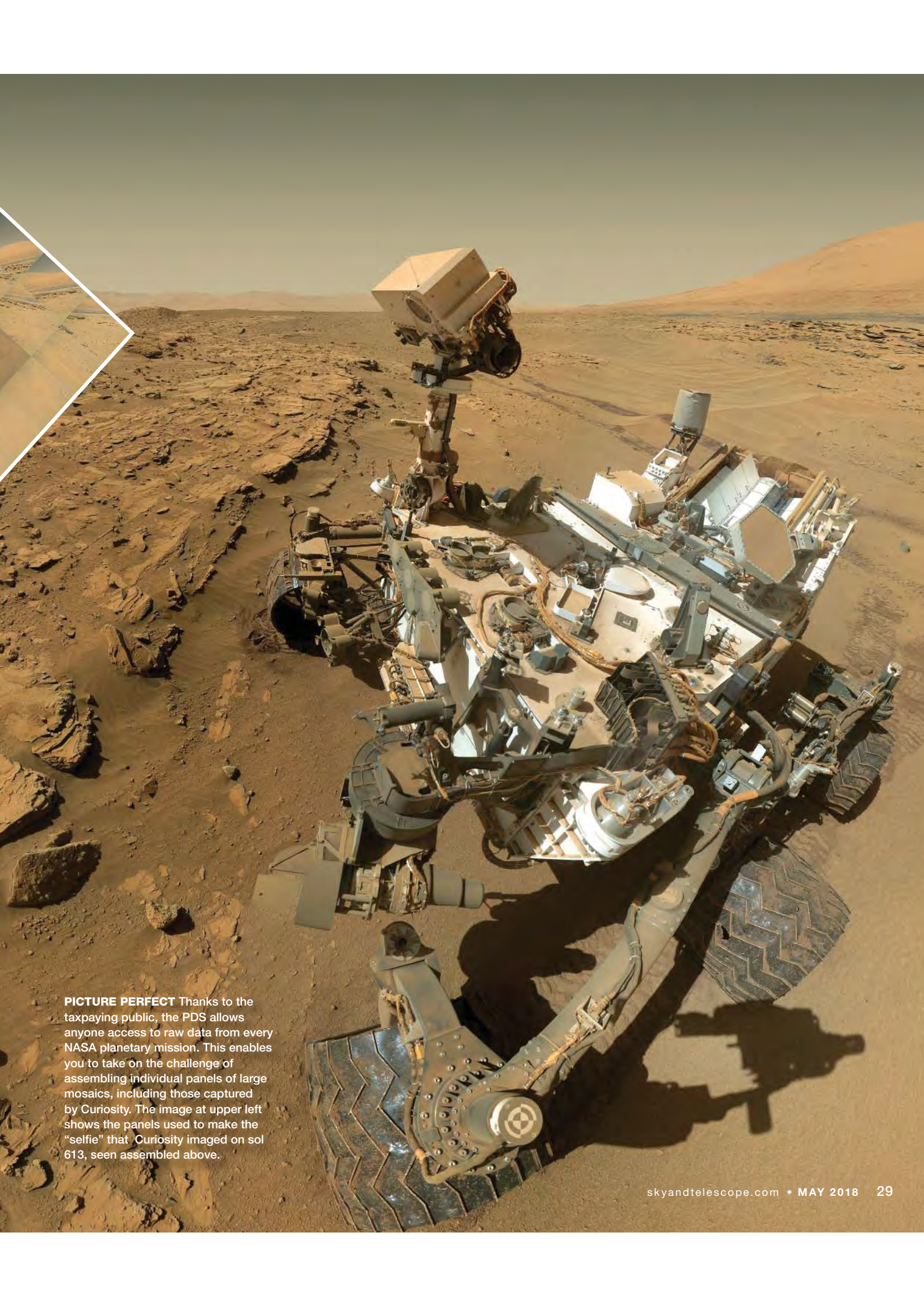

PICTURE PERFECT Thanks to the taxpaying public, the PDS allows anyone access to raw data from every NASA planetary mission. This enables you to take on the challenge of assembling individual panels of large mosaics, including those captured by Curiosity. The image at upper left shows the panels used to make the “selfie” that Curiosity imaged on sol 613, seen assembled above.

1980s, it became clear that the methods for storing and sharing the scientific wealth from NASA missions were insufficient to make sure that the precious data did not get lost over time.

NASA established the PDS to collect and preserve mission data and, crucially, to enable access to them by people beyond the mission team. In a sense, the PDS is a distributed, digital specimen collection. Like any valuable natural-history collection, PDS data sets are curated by skilled and knowledgeable people, themselves experts and often researchers in a relevant field.

Because space science covers so many disciplines, the PDS is subdivided into seven sections called *nodes*. Each of these is devoted to a distinct discipline and managed in a different location by a local team of experts. Researchers and enthusiasts interested in space images will most often encounter four of these nodes:

The Cartography and Imaging Sciences Node (formerly and sometimes still known as the Imaging Node) is housed at NASA's Jet Propulsion Laboratory and collects data from spacecraft cameras and provides form- and map-based tools to search and retrieve it.

The Geosciences Node, at Washington University in St. Louis, stores geology- and geophysics-related data from terrestrial worlds: Mercury, Venus, Mars, the Moon, and asteroid 433 Eros. It provides tools for exploring landed-mission data sets from both the Moon and Mars — not just images, but also spectrometer readings and even mission logs.

The Ring-Moon Systems Node (formerly known as the Rings Node) is based at the SETI Institute in Mountain View, California, and it collects data relevant to planetary ring systems, including images from all the outer-planet missions as well as Hubble photos. This node provides a versatile form-based browsing and data retrieval tool as well as an application programming interface (API) permitting outside developers to write their own software tools. (Full

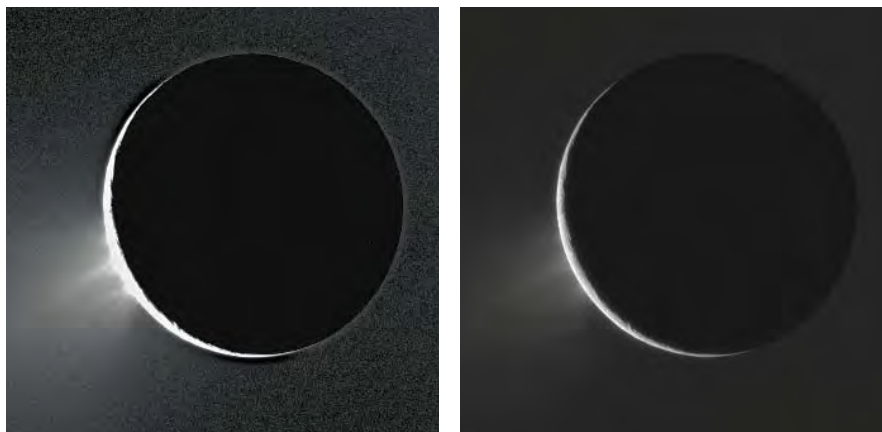

▲ **DIFFERENT PERSPECTIVES** Exploring the raw images often permits users to see different exposures of a particular view than the ones publicly released by NASA. The long exposure of Enceladus at left was used to establish conclusively the existence of its ice jets. Another photo in the same image series used a shorter exposure, producing a more natural appearance.

disclosure: I am on the Advisory Council of the Rings-Moon Systems Node.)

The Small Bodies Node, based at the University of Maryland, collects data on asteroids, comets, and trans-Neptunian objects (including the Pluto system). It also collects ground-based data gathered in support of small-bodies missions.

Where there's overlap between disciplines, more than one node might hold copies of mission data. A single mission's data could be spread across many nodes — camera data in one place, laser-altimeter measurements at another node, and plasma data in a third.

Data Diversity

Solar system missions are varied. They visit large and small targets, observe them close up and far away, under faint or bright conditions, through instruments with a wide variety of capabilities. As a result, the data sets from missions are diverse. Each camera's archive at the PDS is unique, the result of a lengthy negotiation between the mission and the PDS about how data will be supplied, how much and what kind of documentation will accompany it, and how quickly archiving happens after a data set is first acquired.

One goal of the PDS is to preserve the data as close as possible to their original form as received on Earth from the spacecraft. However, very few people know what to do with a raw telemetry stream as received at a radio dish. So the PDS preserves as Experiment Data Records (or EDRs) instrument data that has been converted to a more readable form, such as a plain-text table of data counts for a spectrometer, or a binary-format image file for a camera.

► REDUCED DATA

Unlike Experiment Data Records (EDRs), Reduced Data Records (RDRs) are calibrated and often corrected for geometric distortions. This image of Io was recorded by Voyager 1 through ultraviolet, blue, and orange filters that had been corrected for geometric distortions and removed *réseaux* marks.

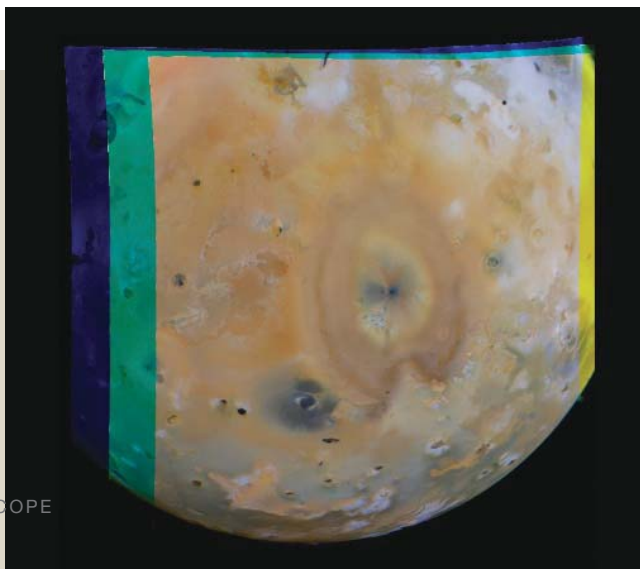

These data are still very raw. Camera EDRs have all kinds of artifacts, with which amateur astrophotographers are painfully familiar. These include detector noise, dark current, vignetting, varying light levels across an image, geometric distortion, and other issues that get in the way of a pretty picture and also in the way of science.

Spacecraft data can be calibrated or resampled to correct for some of these issues. For example, it's common for spacecraft image data to be divided by a model spectrum of incident sunlight to correct for there being different light levels at different times of day. It's also common to mathematically reproject images to correct for lens distortion or to turn photographs of round worlds into flat maps.

Resampled or calibrated data are called Reduced Data Records (RDRs) to distinguish them from EDRs. For any single EDR, there may be multiple RDRs that have had different types of processing applied to them — or there may be no RDRs, only EDRs. Each camera team develops a set of PDS deliverables that is unique to their instrument, which means that enthusiasts who want to play with image data should approach data sets one at a time.

Different Kinds of “Raw”

In 2004, Steve Squyres and Jim Bell of the Mars Exploration Rover (MER) mission initiated a revolution in public participation in image processing. Their idea: Share images from Spirit and Opportunity directly to the internet as soon as they were received on Earth, without waiting for any proprietary period to lapse.

Squyres and Bell thought that sharing the images would also share the excitement of participating in an active Mars mission, while believing the risk of the key results being “scooped” by outside researchers looking at the data was slight. They were right, and their openness with the rover data generated a booming online community of amateur image processors. Cassini, New Horizons, and Curiosity later chose to participate in the same tradition.

The MER, Cassini, and Curiosity raw-image websites use the term “raw” to mean something different from its use at the PDS. Raw-image websites share data that have not been calibrated but have been processed.

When spacecraft data arrive on Earth, they pass through an automated processing pipeline that branches out into two directions. One branch sends EDRs to science teams for inspection. The second produces images for the public that are processed from the EDRs.

The processing is intended to make the images more accessible to the public, but it also (usually) degrades their quality for scientific analysis. Image contrast is stretched to make the brightest pixels white and the dimmest black. They are also saved with lossy JPEG compression, dramatically reducing their file size for easy sharing but also introducing artifacts. (Whole subcultures on the internet have sprung up that seem determined to interpret every JPEG artifact as evidence for alien life.)

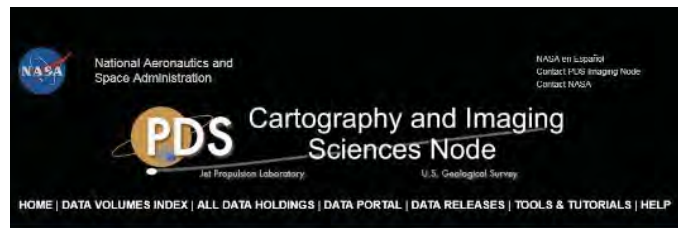

Mission Info	Instruments	Targets	Data Access Documentation, Tutorials	Status
Cassini-Huygens	ISS Radar VIMS	Moon Jupiter Saturn	Atlas Product Search Online Data Volumes Documentation	Latest release #52 includes ISS, RADAR, & VIMS data January 3, 2018
Chandrayaan-1	Moon Mineralogy Mapper (M3)	Moon	Atlas Product Search Online Data Volumes Documentation	Release #4 Volume CHM3_004 containing Chandrayaan-1 Lunar Orbiter (LO-1) Moon Mineralogy Mapper (M3) reduced image data, Optical Period 1 and 2, Level 2 NOTE: there was a minor update to CHM3_003, described in the ERRATA.TXT
Clementine	A-STAR, B-STAR HIRS, UVIS NIR, LAVIS	Moon Earth	Atlas Product Search Online Data Volumes Documentation	Mission Complete Last data received May 7, 1994
Galileo	SSI NIMS	Earth, Moon Venus, Ceres, Iris Jupiter Satellites	Atlas Product Search Online Data Volumes Documentation	Mission Complete Last data received September 21, 2003
Juno	JunoCam	Earth, Moon Jupiter Satellites	Online Data Volumes Documentation	Release #3 ORR11_05_05 December 14, 2017
KAGUYA (SELENE)	LALT LRSI SELENE	Moon	Kaguya Terrain Camera Tutorial JAXA SELENE Data Archive Documentation	Mission Complete
Lunar Reconnaissance Orbiter	LAMP LROC	Moon	Atlas Product Search Online Data Volumes Documentation	Release #32 December 15, 2017 LROC LAMP
Lunar Crater Observation and Sensing Satellite	LCROSS	Moon	Atlas Product Search Online Data Volumes	Release #1 June 9, 2010
Magellan	SAR	Venus	Atlas Product Search Online Data Volumes Documentation	Mission Complete Last data received October 12, 1994
Mariner 9 Mariner 10 Mariner 69	ISS	Mars, Dionys Phobos Mars Venus	Mariner 9 & 10 Online Data Volumes Mariner 69 Online Data Volumes Documentation	Mission Complete Last data received March 16, 1975
Mars Exploration Rover	APXS, DESCAM HAZCAM, MB MI, NAVCAM, PANCAM, RAT	Mars	Atlas Product Search Online Data Volumes Documentation	Latest release #54 December 21, 2017 Sols 4681-4770
ESA Mars Express	HRSC	Mars	Atlas Product Search Product Search via the European Space Agency (ESA) Online Data Volumes Documentation	Latest release March 4, 2015
Mars Global Surveyor	MOC MOLA	Mars Phobos	Atlas Product Search MOC Online Data Volumes Documentation	Mission Complete Last Contact November 2, 2006 Available MOLA data is presently undergoing verification

▲ **DIGGING IN** Each of the PDS's seven nodes is hosted in a different location and appears very different. Shown here is the Cartography and Imaging Sciences Node data portal, which hosts raw images from most spacecraft cameras, imaging spectrometers, and imaging radars.

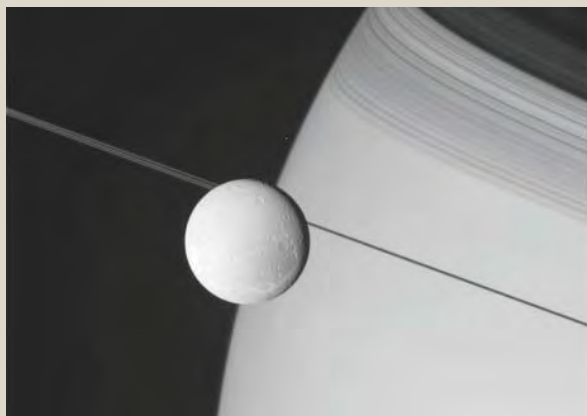

So-called “raw” JPEGs provide an easy entry point for users just beginning to explore spacecraft data, and they’re invaluable for browsing and for keeping track of active missions. But users who want to find art in mission data sets should take the trouble to dig into the PDS archives for science-quality data in all its subtle contrast and original detail.

Where to Begin?

So many data sets — where to start? At the beginning, with Mariners 6 and 7’s 1969 data at the Imaging Node? Or relive the discovery of the landscapes of the moons of Uranus and Neptune by Voyager 2 at the Rings-Moon Node? Or perhaps follow along with the active Opportunity mission at the Geosciences Node?

My advice is to begin with Cassini. Cassini’s cameras took crisply detailed photos that are nearly free of geometric distortion. Almost every target in the Saturn system is stunning. And the difference in quality between raw JPEGs and calibrated RDRs rewards the effort it takes to retrieve the data.

There are lots of ways to have fun with Cassini data: You can look at portraits of moons from different perspectives, mosaic multiple frames together for large panoramas, compile sequential images into flyby animations, and composite various filtered photos into natural or representative color results, among other possibilities.

Cassini data are hosted at both the Ring-Moon Systems Node and the Imaging Node. The first of these is an excellent place to begin, thanks to its Outer Planets Unified Search (OPUS) tool. Users can access OPUS through an online form or even develop their own search tools, because OPUS has an API that’s accessible to outside coders.

Approaching a New Data Set

Begin by browsing, to get a sense of what a data set contains and what possibilities there are for processing. OPUS currently indexes more than 1.4 million data products; if you “browse results” without checking any boxes in the form, you start at the beginning with Voyager 1’s images taken as it approached the Jupiter system in 1979.

Return to the “Search” page, and you can rapidly limit the search results to home in on items of interest. Using the “General Constraints” function allows you to limit the results by mission (choose Cassini) and/or instrument (choose Cassini ISS to remove results from more-difficult-to-handle spectrometer data). There are nearly 400,000 entries in the OPUS database — one for each EDR from the Cassini camera.

The OPUS browse page is populated with multicolored image thumbnails. The colors signify what filter an image

◀ **COLOR COMPOSITE** Assembling color images from Cassini is a popular pastime for citizen scientists. The author assembled this extended-color image of Dione, captured as it was passing in front of Saturn, using images captured through ultraviolet, green, and infrared filters, seen here in descending order. The color result seen at left required lots of work, due to both the spacecraft’s and the moon’s movements between frames.



was taken through. Cassini's cameras, like most sent to deep space, are monochrome detectors; they obtain color information by placing a filter in front of the camera. You can make color images by compositing three different-filtered images together in most photo-editing software.

The OPUS search results allow you to quickly scan for the red, green, and blue filter combination needed to make an approximately natural-color image, or ultraviolet-, green-, and infrared-filtered images that can make an extended-color composite. (OPUS represents ultraviolet-filter images in a purple color and infrared-filter ones in darker red.) Other choices include methane or continuum-band filters — both in infrared wavelengths — used to pick out subtle cloud structures deeper in Saturn's atmosphere than visible wavelengths permit, or to allow glimpses of Titan's surface.

I particularly like the "Surface Geometry" search option in the OPUS tool, which allows you to select a target (say, a moon like Enceladus) and then filter the results by the distance to the target, image resolution, or lighting geometry. That way, if I am interested only in full-globe photos, or if I'm only interested in crescent-phase views, they are easy to find.

As you see images you like, you can tick a checkbox on each one, and download them all as a ZIP compressed file

▲ **OLD IS NEW** The ability to process old mission data using modern image-processing software allows far better results, such as this series of images taken by one of the Viking Orbiters as it approached Mars in 1976.

from the "selections" tab. You will end up with image files with .IMG file extensions — these are raw-format images, which you can often open with Photoshop, GIMP, or other image-processing software after changing the file extension from .IMG to .RAW and manually entering the image dimensions. For instance, the imaging camera detectors aboard Cassini were 1,024 × 1,024 pixels. If that doesn't work, you can use the file conversion program *IMG2PNG* found at <https://is.gd/WQZ9yy>. You will also find a text file (with an .LBL extension) for each image, which contains metadata describing the particular observation: when it was taken, through what filter, how many lines and samples it has, where it was pointed, and much more.

Treasures from the Trunk

Not all of Cassini's 400,000 images are publication-worthy, but the number of them that were captioned and shared on the mission's website represents barely 1% of the total. Therefore, anybody who digs into the data stored in the PDS is

MOONS TO SCALE One informative exercise the author performed was to assemble this montage of Saturnian moons depicted accurately to scale. While it wasn't necessary to find images shot at the same scale, it was essential to find each moon shot at nearly the same lighting.

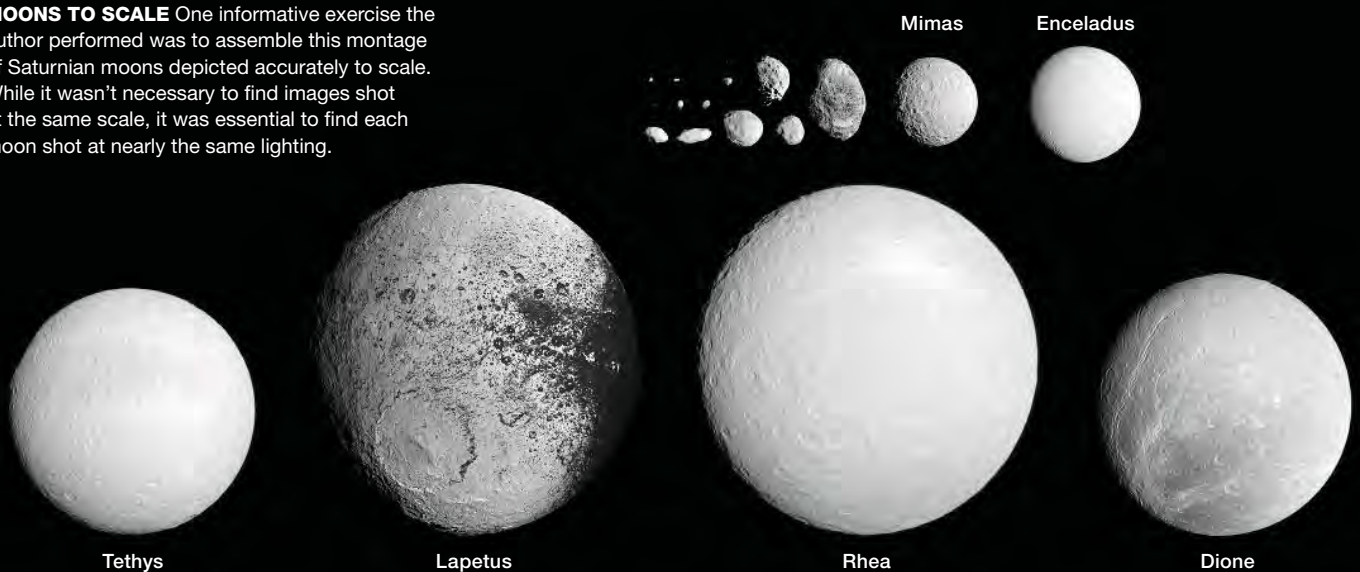

Where To Find Mission Data

Browse raw JPEG Curiosity images at either midnightplanets.com or curiosityrover.com. Midnightplanets also hosts Spirit and Opportunity raw JPEGs. Afterward, dive into the Analyst's Notebook at the Geosciences Node for all the archival rover and Phoenix science data here: an.rsl.wustl.edu.

Mars Pathfinder and Viking Lander data are found at the Imaging Node: pds-imaging.jpl.nasa.gov/portal.

The best place to browse high-resolution and wide-angle Mars Reconnaissance Orbiter images is the HiRISE website at hirise.lpl.arizona.edu. Raw JPEGs are available, but you can get archival PDS-quality data in JP2 format there as well.

To find images of specific locations on Mars, I like the ASU Mars Global Data website for not only HiRISE data but also Viking Orbiter, Mars Global Surveyor MOC, Odyssey THEMIS, Mars Reconnaissance Orbiter CTX, and Mars Express HRSC images: global-data.mars.asu.edu. There's both a map-based search tool and a form-based tool.

The Mariner 6, 7, 9, and 10 data sets were added to the Imaging Node of the PDS by copying old magnetic tapes. These data sets don't have as much metadata or documentation as modern ones do, making them especially difficult to approach, but they can also be especially rewarding. pds-imaging.jpl.nasa.gov/portal.

Magellan Venus radar images can be individually downloaded from the Imaging Node, but the data is better approached in its global mosaic form, which you currently can do at www.mapaplanet.org. The USGS is phasing out this older version of Map-A-Planet in favor of a newer version that is more powerful but less user-friendly for armchair explorers: astrogeology.usgs.gov/tools/map-a-planet-2.

Browse raw Cassini JPEG images at saturn.jpl.nasa.gov. Voyager 1 and 2, Galileo, Cassini, and New Horizons images are all available from both the Imaging Node and the Rings Node, but the

OPUS search tool at the Rings Node is incredibly user-friendly: tools.pds-rings.seti.org/opus.

Juno's JunoCam images are available at the Juno website as well as the Imaging Node located at both missionjuno.swri.edu/junocam/ and pds-imaging.jpl.nasa.gov/portal/juno_mission.html.

Both Messenger and Dawn have dedicated map-based tools to aid browsing for orbital data from their data sets: messenger.jhuapl.edu/Explore/Quick-Map-Orbital-Data.html and sbib.psi.edu/. For images of targets that are not Mercury, Ceres, or Vesta, it's best to go to the Imaging Node instead.

Asteroid and comet mission images including Dawn, Deep Impact and EPOXI, Deep Space 1, NEAR, New Horizons, and Stardust are hosted at the Small Bodies Node: pds-smallbodies.astro.umd.edu.

ARCHIVES FOR OTHER SPACE AGENCIES:

ESA's Planetary Science Archive: archives.esac.esa.int/psa/.

ESA Archive Image Browser (Rosetta only): imagearchives.esac.esa.int/.

ISRO's Mars Orbiter Mission mrbrowse.isdc.gov.in/MOMLTA/.

China's Lunar Exploration Project data: moon.bao.ac.cn/index_en.jsp.

JAXA data: darts.isas.jaxa.jp/planet/.

EXPANDING THE VIEW Stitching together wide panoramas, such as this recent view of Gale crater captured by Curiosity, is a popular pastime for citizen scientists scouring the mission's latest data release.

likely to find obscure images. Even images or observations that are familiar can often be processed differently, to emphasize features hidden in shadow or washed out by bright light. There are many ways to approach data.

Consider the Cassini image sequence that unequivocally proved the existence of south-polar plumes at Enceladus. The mission chose to release a long-exposure photo, in which the crescent of Enceladus is saturated and the individual jets make obvious pointed spikes. From the same sequence, I found a shorter-exposure image, in which surface detail in the sunlit crescent is visible, while the plumes appear as a subtle mist against the background sky (seen on page 30). Neither is better; they're different photos, each worth appreciating.

Once you've learned how to work with the relatively straightforward Cassini data, it's even more rewarding to turn your attention to earlier missions, particularly the ones from the 1970s. Those data sets are more difficult to work with: more distortion, more blur, less bit-depth, less documentation, and on and on. But there is a huge difference between what 1970s spacecraft engineers could achieve in image processing when those missions were active and what a self-educated 21st-century space fan with a garden-variety personal computer can achieve now.

Anybody who digs into the data stored in the PDS is likely to find obscure images. Even images or observations that are familiar can often be processed differently, to emphasize features hidden in shadow or washed out by bright light.

My favorite example of this contrast comes from Viking. A friend in the image-processing enthusiast community, Ted Stryk, shared a photo he had processed from data returned to Earth by the Soviet Union's ill-fated Mars 3 mission. It shows a crescent-phase Mars that looks almost like Titan because its surface is hidden from view behind a global dust storm. When I shared it on Twitter, I remarked that it was the first time I'd seen such a high-phase photo of Mars (except from the VMC camera on Mars Express).

Someone responded to correct me, mentioning a similar-phase image taken as one of the twin Viking orbiters approached the planet in 1976. I Googled for it and found an astonishingly ugly image on a NASA website. Sure that I could do a better job, I went digging into the Imaging Node in search of Viking's Mars approach images. I found not just one, but six breathtaking color crescent-phase photos of the planet, data that had been waiting all this time for me to brush off the dust, polish it, and put it on display for all to see. Many more such treasures await the brave explorers who search for them. I encourage all of you to try!

■ Contributing Editor EMILY LAKDAWALLA blogs for the Planetary Society at planetary.org/blogs and frequently hunts for overlooked gems in the PDS.



Meade's 115-Millimeter ED Triplet

This 4.5-inch apochromat packs a lot of bang for the buck.

115mm Series 6000 ED Triplet APO

U.S. Price: \$1,899
meade.com

What We Like

Sharp, well-corrected optics

Color-free views

Attractive finish

What We Don't Like

Visual back locking
system can be awkward

Focuser backlash

THIS IS A GREAT TIME to be in the market for a premium refracting telescope. The price for high-quality refractors has fallen dramatically in recent years, and you can now purchase a 4- to-5-inch extra-low dispersion (ED) apochromatic (APO) telescope that's almost entirely free of the false color that plagues achromats for a fraction of the cost commonly seen a decade ago.

I've had a ball with my own recently purchased apochromat after using almost nothing but Schmidt-Cassegrain telescopes for many years. However, I still consider myself a refractor nov-

ice and was eager to see how others performed. So when I was approached about evaluating Meade's 115mm Series 6000 ED Triplet APO, I was certainly up for the task.

First impressions are important, and when I unboxed the scope on the day it arrived, I lit up when I saw it. This is

▼ The Meade 115mm Series 6000 ED Triplet APO ready for a night's activity, shown with an optional 2-inch mirror diagonal. The scope also accepts finderscopes that attach using a standardized dovetail system commonly found on small refractors.



a pretty refractor. Although similar in appearance to many current APOs, it has the distinctive “Meade” blue lens cap and trim. The build quality is very good for the price; not quite the same as units costing twice as much or more, but solidly built. The multi-coated objective coatings were visibly effective; incident light falling on the lens seemed to practically disappear.

The scope includes a 3-inch Crayford-style focuser with a 10-to-1 fine-focus knob that incorporates a non-marring compression-style system to secure your star-diagonal, camera, or eyepiece. The focuser itself can be rotated independently of the tube, a big help for astrophotographers when composing shots. Up front is a sliding dew shield that can be retracted when installing solar filters, or to save space when storing or transporting the scope.

Accessories included with the 115 ED are few. A nice set of tube rings are bolted to a robust Vixen-style dovetail bracket. The rings are drilled on top to accommodate an optional bracket for a guide telescope or other accessories.

Finally, there’s an attractive lightweight carrying case for the telescope. While this aluminum-framed plastic case holds the scope snugly in place with die-cut foam and is sufficient for storing and transporting the scope, it’s not meant to take much abuse.



▲ The telescope’s 4½-inch triplet objective showed reflections only under bright sunlight.

Meade provided several optional accessories with the telescope, including a 2-inch mirror star diagonal, though no finderscope, which is an extra-cost option. Luckily, the scope is fitted with the industry-standard finder base, which permitted me to use the 50-mm finderscope from my own refractor.

The 115 ED is an f/7 triplet refractor with one ED element to improve color correction. This is a sizeable aperture telescope as APO refractors go, yet it weighs in at a mere 12.2 pounds.

I was curious to see how well this reasonably priced 115mm APO performed, and was expecting good things. How much detail can this modest aper-

ture produce on some of my favorite targets? As you’ll see, this refractor novice now concedes that some of the stories about the telescopes’ performance I used to dismiss as myths are true.

First Light

When you take the false color of simple achromatic objective lenses out of the refractor equation, you are left with an instrument featuring superior sharpness and contrast thanks to the lack of an obstructing secondary mirror, which reduces contrast in the views through reflectors and compound telescopes.

While the 115mm would not have stressed out my lightweight Go To German equatorial mount (GEM), I chose to place the Meade on my 50-pound-payload-capable GEM to give the scope its best chance to shine. The triplet is noticeably front-heavy, thanks to its 3-element objective lens. Fortunately, the tube rings provide plenty of room to find balance even with heavy eyepieces, binoviewers, or cameras attached.

First light in my backyard was spent soaking in views of bright stars and the first quarter Moon. Nothing tests the mettle of a refractor like our nearest celestial neighbor. But first I turned to brilliant Vega, riding high in the West. While it’s not uncommon for an ED refractor to display a little color fringing on a bright star that’s slightly out



▲ *Left:* The beefy 3-inch focuser included with the 115 ED includes a blue anodized 10-to-1 fine-focus knob. *Right:* The unit’s drawtube is marked in centimeters to help quickly repeat focus with your favorite eyepieces and other accessories. The 2½- to 2-inch visual back can be independently rotated by holding the large knurled ring and turning the “captain’s wheel” with aluminum pegs.

of focus, this wasn't the case with the Series 6000. Vega was an icy blue, both in perfect focus and just barely either side of focus.

And views of the Moon? If I tried, I could see an unobtrusive yellow-green rim on the lunar limb, but that was it. The terminator was awash with sharp craters, and the shadows within were inky black, without a hint of the purple tinge often seen in a lesser instrument. My main impression, however, was the sharpness of the lunar landscape.

One other thing I appreciated was the Meade's f/7 focal ratio. While f/6 APOs are popular, I found the scope's slightly longer-than-average focal length allowed me to use somewhat longer (and more comfortable) eyepieces to reach high powers. The telescope took all the magnification I could throw at it under good seeing.

Star tests on the 115 were as I had hoped. Diffraction ring patterns of a slightly out-of-focus star on both sides of focus looked nearly identical, a sign that its objective is well-corrected.

While I observed a few deep-sky objects from my backyard, I did most of my deep space cruising on a visit to the Deep South Star Gaze in the dark piny

▼ The Meade 115mm Series 6000 ED Triplet is shipped in a hard-sided plastic case with metal trim and form-fitting foam.



woods of Louisiana. It was amazing what this scope could do for globular star clusters.

Looking at M15 in Pegasus, I had to keep telling myself this was a "small" telescope. The relatively tight globular can be a test for instruments in this aperture range, but not for the 115. I was easily able to resolve its outer halo of stars, both because they were tiny in the telescope's sharp images and because its excellent optical quality allowed me to really push the magnification, making resolution easier.

Although the 115 did a nice job on medium-sized deep-sky targets, it was with the big objects that it really shone. With a 35-mm wide-field eyepiece in



the focuser, I had stunning views of the huge North America Nebula (NGC 7000) and both bright sections of the Veil Nebula. While the scope doesn't provide a lot of aperture horsepower, I was still amazed at what this modest refractor could reveal. Not only were the east and west loops of the Veil visible, but with the aid of a light-pollution reduction filter I was also able to detect Pickering's Triangle, the dim patch of nebulosity lying between the two halves of the Veil. Of the big galaxies, M31 was particularly marvelous, easily showing off one dust lane. Andromeda's normally subdued satellite galaxy, M110, was bright and obvious.

Imaging Performance

The Meade 115 ED functioned well visually, but that's only part of the power of these instruments. The critical question was whether this reasonably priced telescope would be up to the rigors of deep-sky astrophotography. In imaging, mechanical soundness is at least as important as optical quality. I'd been impressed with the focuser and other mechanical qualities of the

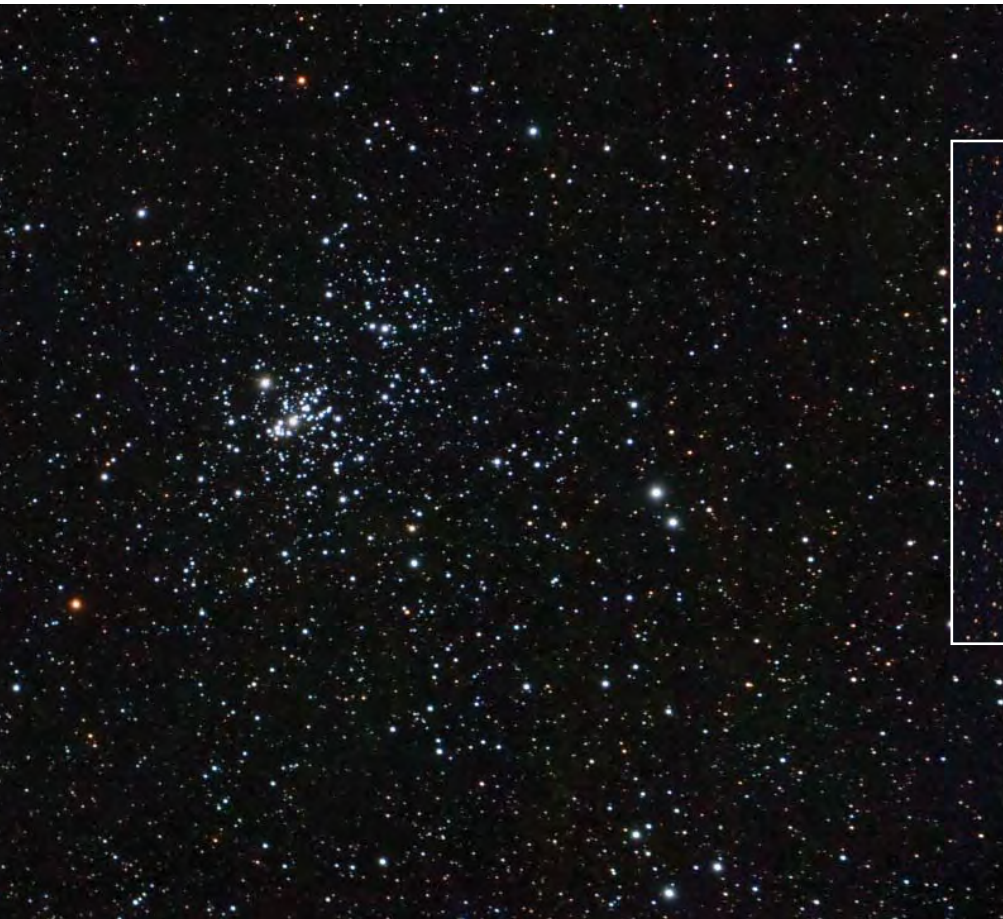

◀◀ Views of the Moon were color-free, with inky-black shadows within the craters along the limb at first quarter.

◀ The star field around NGC 869 and NGC 884, the Double Cluster, was tack-sharp when using field-flatteners. The author used an off-brand flattener for this photo that doesn't reduce the telescope's focal length, to take full advantage of the scope's resolving power.

▲ Although a relatively small target for a 4½-inch instrument, M27, the Dumbbell Nebula, displays a wealth of detail in this image captured with the 115 ED and a Canon 400D DSLR operating at f/7.

imaging as for visual observing. While it doesn't provide quite the wide field of faster focal ratios, the 115mm f/7 still delivers plenty to work with, particularly by offering a larger image scale. The reward for shooting at f/7 was that it allowed me to expose longer in my light-polluted yard before the sky background became overwhelmingly bright.

What's the best compliment I can give the Meade Series 6000 115mm ED Triplet APO refractor? I was sorry to see it go when the time came to return it. My biggest surprise was how much I enjoyed using this small scope visually. While there's no such thing as an all-purpose telescope, this excellent instrument was as close to that as any telescope I've used in a long time.

■ After decades of using SCT's, Contributing Editor **ROD MOLLISE** has recently embraced the joys of astronomy observing through refracting telescopes.

115mm during my visual run, but astrophotography will stress any telescope.

The typical weak link in refractors is the focuser. The Meade's 2½-inch Crayford-style focuser acquitted itself well in the most crucial test. I inserted my heaviest DSLR camera and field flattener into the focuser and pointed the telescope near the zenith. Would it slip without the focuser being locked down? Nope. Despite its easy focusing action, it never even threatened to slip. I can forgive many focuser faux pas if this requirement is met. The unit also had plenty of range; I had no problem bringing any camera or eyepiece combination into focus, though I secured the draw tube lock knob when imaging.

There were, however, a few minor deficiencies with the scope's focuser. While the 10-to-1 fine-focus knob is a boon for achieving sharp images, this particular telescope's fine focus action exhibited some backlash. I'd focus inward, let go of the knob, and it would spring back slightly. Although this never prevented me from achieving proper focus, it was nevertheless something I always needed to be aware of.

The other thing I had concerns with was the focuser's visual back. This is a ring with three "captain's wheel"-style pegs. In typical operation, you insert a star diagonal or camera and rotate the ring clockwise using the pegs for added grip on the collar to secure the chosen accessory. While my heavy DSLR was held securely, rotating the visual back counterclockwise to remove the diagonal or camera would sometimes loosen the whole visual back, which screws onto the scope's focuser. Not a fatal flaw, but annoying nevertheless.

As for the telescope's imaging performance on deep-sky objects, I gave that a high grade. Without a field flattener like Meade's optional Series 6000 model, stars near the field edge are radially elongated, as is typically seen in an uncorrected refractor. But inserting the flattener completely removed the distortion, producing sharp, round stars right to the edge of my camera's APS-C format detector. Stars looked remarkably clean and fringe-free across the entire field.

In my backyard, the f/7 focal ratio of the Meade proved as much of a plus for

NEW

Our Highest Payload **Capacity** Center Balance Equatorial Mounts and a Rugged Support Worthy of Bearing The Load.

CEM120

The naturally stable center balance equatorial mount is sure to satisfy even the most discriminating observer. With its 115-lb. maximum payload, smooth and quiet mechanical operation, built-in Wi-Fi, low +/- 3.5 arcsecond periodic error, and advanced cable management system, the CEM120 clearly meets the performance and functionality demands for observing and astrophotography.

CEM120EC

Offering all the capabilities of the CEM120, the CEM120EC adds a high-resolution encoder to the RA axis, enabling an incredibly low periodic error of <0.15 arcsecond RMS, accuracy capable of guider-free imaging.

CEM120EC2

With a second high-resolution encoder added to the declination axis, the CEM120EC2 delivers sub-arcsecond tracking along with advanced sky-modeling functionality. As always, the CEM120 series mounts firmware is upgradable by a simple firmware download.

Tri-Pier 360

Combining the strength and stability of a pier with the leveling flexibility of a tripod, the TriPier 360 supports up to 360 lbs. Its solid 1/4-inch thick walled aluminum alloy pier with CNC-machined legs and adjustable feet deliver the versatility needed for a portable support. (iOptron permanent piers also available)



MAP
CEM120 \$3,999.00
CEM120EC \$5,500.00
CEM120EC2 \$6,998.00

MAP
Tri-Pier 360 \$899.00



© 2018 iOptron® All rights reserved

TelescopeS.NET

by Woodland Hills Camera & Telescopes



NEW CGX
Premium EQ mount
55lb. capacity



MEADE
LX850
Built-in guiding
for imaging



EXPLORE
SCIENTIFIC

80mm f/6, perfect travel scope!



ZWO Camera
ASI1600 MMP
The new ZWO camera
with a big chip



SBIG
IMAGING SYSTEMS
SBIG Camera
The new Aluma
694 cameras
are here



The Eagle total control.
No twisted cables,
long lasting
battery!



888-427-8766 Intnl: 818-347-2270 • 5348 Topanga Canyon Boulevard, Woodland Hills, CA 91364

OBSERVING

May 2018

2 DUSK: Aldebaran and Venus, separated by a little more than 6° , set together in the west-northwest.

4 EARLY MORNING: The waning gibbous Moon, Saturn, and Lambda (λ) Sagittarii (the top star of the Teapot in Sagittarius) form a triangle; Mars trails them as they travel from east to west.

6 PREDAWN: The Eta Aquariid meteor shower, often the best meteor shower for the Southern Hemisphere, peaks in the early morning. Viewers in the southern United States should look toward the eastern horizon, although the waning gibbous Moon may interfere somewhat; see p. 51.

8 EVENING: Jupiter reaches opposition; see page 48.

17 DUSK: The thin waxing crescent Moon joins Venus as they set, some 6° separating them.

19 EVENING: The Moon, in Cancer, hangs 6° below the Beehive Cluster (M44).

20 DUSK: Venus hovers less than 1° right of the open star cluster M35 in Gemini.

21 EVENING: The first quarter Moon and Regulus form a tight pair — less than 1° separates the two.

25 ALL NIGHT: Watch as Spica and the waxing gibbous Moon cross the sky in tandem a little more than 6° apart.

26 ALL NIGHT: The Moon has moved closer to Jupiter; the pair forms a long triangle with Spica.

31 ALL NIGHT: The waning gibbous Moon and Saturn rise 2° apart; watch as the separation grows to 4° before sunrise.

M44 is an open cluster in Cancer.

PRESTON S. JUSTIS / S&T ARCHIVES

MAY 2018 OBSERVING

Lunar Almanac





Northern Hemisphere Sky Chart



Yellow dots indicate which part of the Moon's limb is tipped the most toward Earth by libration.
NASA / LRO

MOON PHASES

SUN	MON	TUE	WED	THU	FRI	SAT
		1	2	3	4	5
6	7	8	9	10	11	12
13	14	15	16	17	18	19
20	21	22	23	24	25	26
27	28	29	30	31		

 LAST QUARTER	 NEW MOON
May 8 02:09 UT	May 15 11:48 UT
 FIRST QUARTER	 FULL MOON
May 22 03:49 UT	May 29 14:19 UT

DISTANCES

Apogee	May 6, 01 ^h UT
404,457 km	Diameter 29' 32"
Perigee	May 17, 21 ^h UT
363,776 km	Diameter 32' 51"

FAVORABLE LIBRATIONS

• Lavoisier Crater	May 12
• Bragg Crater	May 13
• Abel Crater	May 23
• Mare Australe	May 26

-  Galaxy
-  Double star
-  Variable star
-  Open cluster
-  Diffuse nebula
-  Globular cluster
-  Planetary nebula

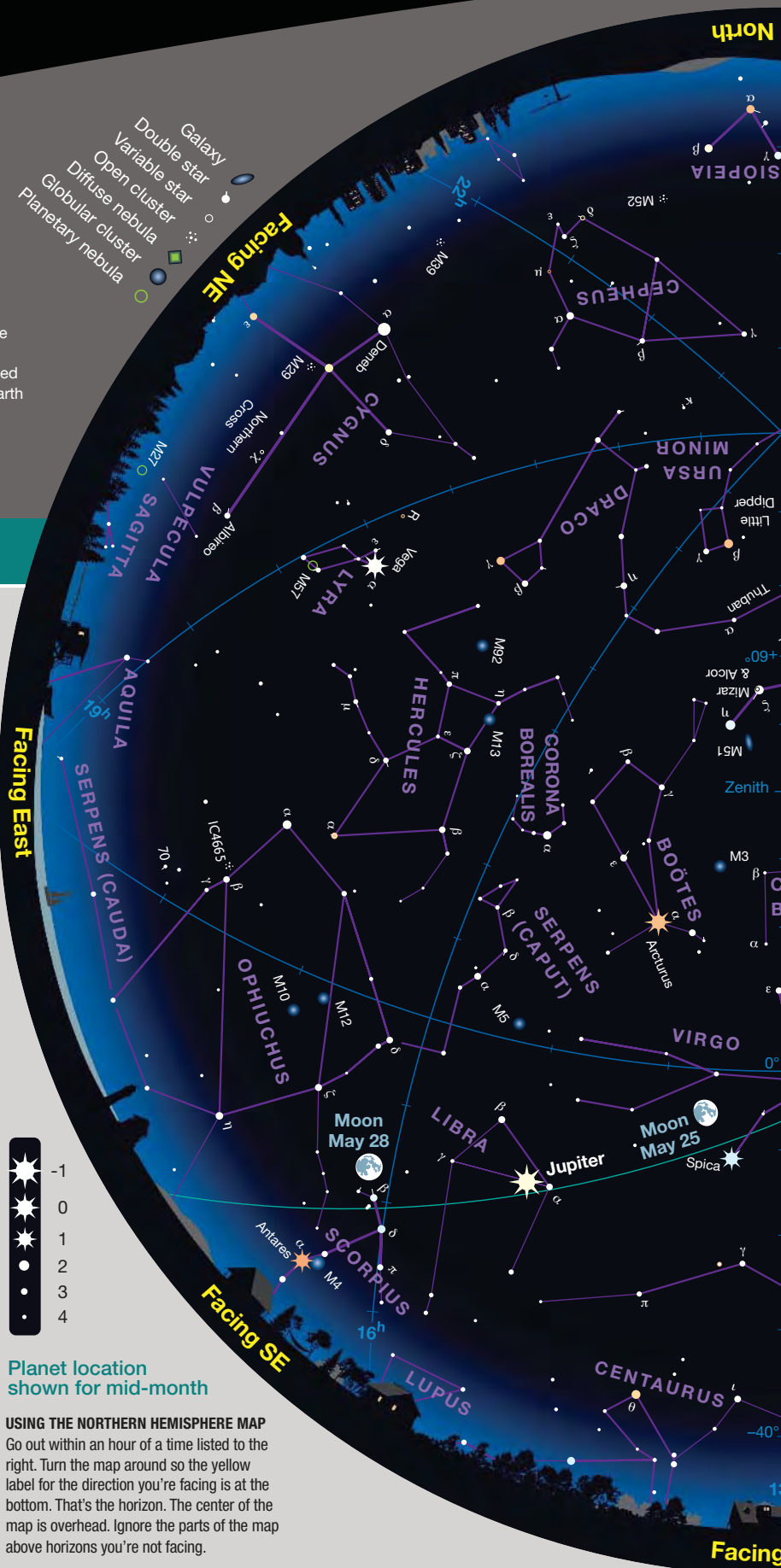

Planet location shown for mid-month

USING THE NORTHERN HEMISPHERE MAP
Go out within an hour of a time listed to the right. Turn the map around so the yellow label for the direction you're facing is at the bottom. That's the horizon. The center of the map is overhead. Ignore the parts of the map above horizons you're not facing.

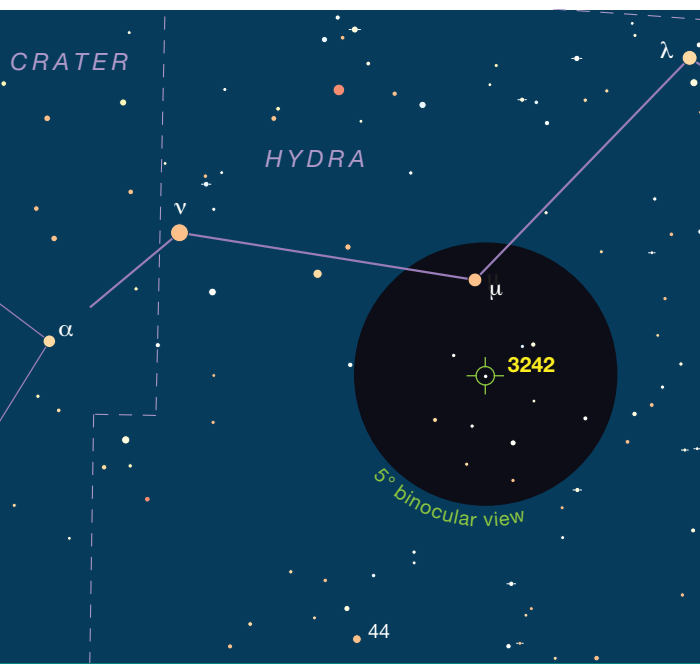

Binocular Highlight by Mathew Wedel

Small But Fierce

NGC 3242, the Ghost of Jupiter (Caldwell 59), is a planetary nebula — concentric shells of gas blown off by a dying star, which reminded early observers of planets in size, shape, and, in this case, even color. Planetary nebulae are mostly small and dim as seen from Earth, and few of them are within reach of binoculars.

NGC 3242 is small, about 0.7' across, or half the diameter of the Ring Nebula (Messier 57), but it's not dim. Most sources give a visual magnitude of 7.7 for it. In his book *The Caldwell Objects*, Stephen James O'Meara reported that at 23× in a 4-inch scope, NGC 3242 still looked basically stellar. However, specifically because its light is condensed into such a small area, O'Meara reckoned that it ought to be naked-eye visible under sufficiently dark skies. A handful of observers have since confirmed that possibility.

Here's your mission (should you choose to accept it). First, go have a look at NGC 3242. I mean, you will see it. And even if it just looks like a point of light, we shouldn't get too blasé about witnessing the death throes of a *star* across a gulf of thousands of light-years with handheld instruments. Second, see if you can detect the nebula with your naked eyes. Others have done it — can you? If not, what's the smallest instrument or least magnification you need to pick it up? Third, if you're rolling with big bins or a small telescope, determine the least magnification required to see the nebula as an extended, non-stellar object. Finally, assuming you're up late enough this month, swing east and have a look at M27, the Dumbbell Nebula, and M57, and see how they compare.

■ **MATT WEDEL** and NGC 3242 are, in the words of Leslie Peltier, making mutual estimates of each other's brightness.

WHEN TO USE THE MAP

Late March	2 a.m.*
Early April	1 a.m.*
Late April	Midnight*
Early May	11 p.m.*
Late May	Nightfall

*Daylight-saving time

MAY 2018 OBSERVING
Planetary Almanac

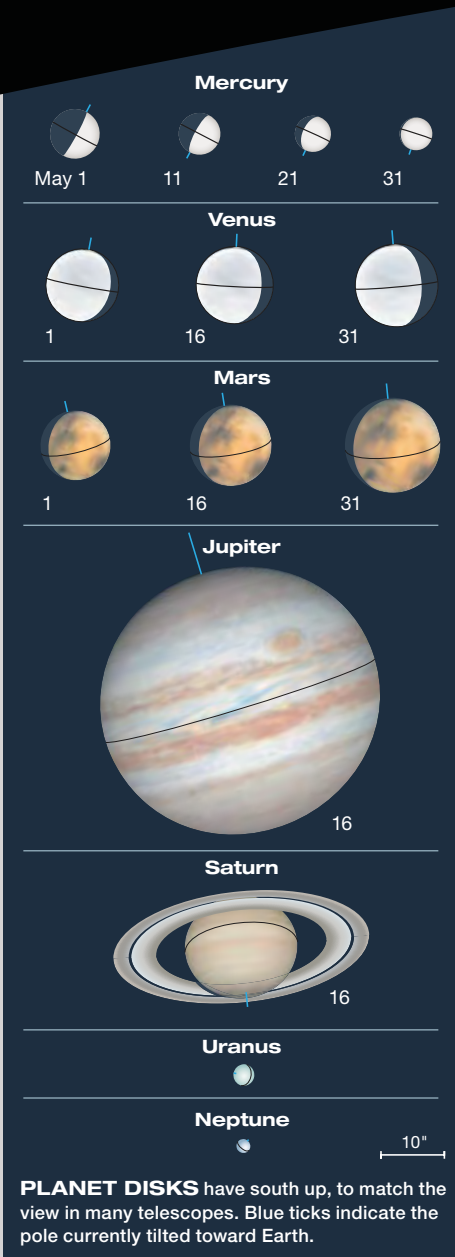

PLANET VISIBILITY: **Mercury:** hidden in the Sun's glow all month • **Venus:** visible at dusk • **Mars:** rises near midnight, highest near dawn • **Jupiter:** visible at dusk, highest near midnight • **Saturn:** rises late evening, visible until dawn

May Sun & Planets

	Date	Right Ascension	Declination	Elongation	Magnitude	Diameter	Illumination	Distance
Sun	1	2 ^h 31.7 ^m	+14° 55'	—	-26.8	31' 45"	—	1.007
	31	4 ^h 30.3 ^m	+21° 50'	—	-26.8	31' 33"	—	1.014
Mercury	1	0 ^h 54.1 ^m	+2° 41'	27° Mo	+0.3	7.8"	46%	0.859
	11	1 ^h 40.6 ^m	+7° 21'	24° Mo	-0.1	6.6"	61%	1.018
	21	2 ^h 41.5 ^m	+13° 39'	18° Mo	-0.6	5.7"	79%	1.177
	31	3 ^h 59.4 ^m	+20° 13'	7° Mo	-1.6	5.2"	96%	1.298
Venus	1	4 ^h 21.8 ^m	+22° 23'	27° Ev	-3.9	11.5"	88%	1.450
	11	5 ^h 13.8 ^m	+24° 17'	30° Ev	-3.9	11.9"	86%	1.397
	21	6 ^h 06.6 ^m	+25° 03'	32° Ev	-3.9	12.4"	83%	1.340
	31	6 ^h 59.0 ^m	+24° 38'	34° Ev	-3.9	13.1"	81%	1.278
Mars	1	19 ^h 41.0 ^m	-22° 44'	107° Mo	-0.4	11.1"	88%	0.845
	16	20 ^h 09.1 ^m	-22° 09'	115° Mo	-0.8	12.9"	89%	0.726
	31	20 ^h 31.6 ^m	-21° 47'	124° Mo	-1.2	15.1"	91%	0.619
Jupiter	1	15 ^h 08.1 ^m	-16° 16'	171° Mo	-2.5	44.7"	100%	4.413
	31	14 ^h 53.4 ^m	-15° 18'	156° Ev	-2.5	44.2"	100%	4.462
Saturn	1	18 ^h 37.9 ^m	-22° 16'	122° Mo	+0.4	17.5"	100%	9.502
	31	18 ^h 32.4 ^m	-22° 21'	152° Mo	+0.2	18.1"	100%	9.161
Uranus	16	1 ^h 51.5 ^m	+10° 54'	25° Mo	+5.9	3.4"	100%	20.799
Neptune	16	23 ^h 09.7 ^m	-6° 25'	69° Mo	+7.9	2.3"	100%	30.291

The table above gives each object's right ascension and declination (equinox 2000.0) at 0^h Universal Time on selected dates, and its elongation from the Sun in the morning (Mo) or evening (Ev) sky. Next are the visual magnitude and equatorial diameter. (Saturn's ring extent is 2.27 times its equatorial diameter.) Last are the percentage of a planet's disk illuminated by the Sun and the distance from Earth in astronomical units. (Based on the mean Earth-Sun distance, 1 a.u. is 149,597,871 kilometers, or 92,955,807 international miles.) For other dates, see skyandtelescope.com/almanac.

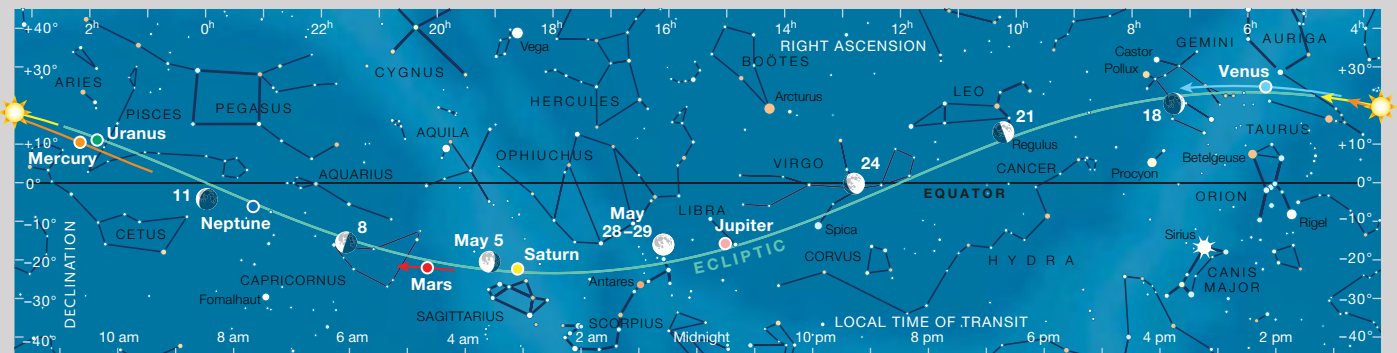

The Sun and planets are positioned for mid-May; the colored arrows show the motion of each during the month. The Moon is plotted for evening dates in the Americas when it's waxing (right side illuminated) or full, and for morning dates when it's waning (left side). "Local time of transit" tells when (in Local Mean Time) objects cross the meridian — that is, when they appear due south and at their highest — at mid-month. Transits occur an hour later on the 1st, and an hour earlier at month's end.

In the Path of the Closest Comet

From Draco to Cancer a comet hurtled.

"The closest — and I do mean closest — thing that anyone alive has ever seen to a comet's colliding with Earth I saw outstandingly well in 1983."

— Fred Schaaf, *Comet of the Century*

Thirty-five years ago this month I got some of the best weather in the world to help me experience a prodigious wonder most skygazers missed. It was the nearest pass to Earth of a comet in over 200 years. The marvel was Comet IRAS-Araki-Alcock (Comet I-A-A), discovered first by the Infrared Astronomical Satellite and then independently by amateur astronomers Genichi Araki in Japan and George Alcock (with binoculars out a window) in England.

I spent six nights following this intrinsically dim comet through ever brighter and bigger forms as it hurtled less than 3 million miles from Earth. Its path across the stars on those nights is one I'll never forget — and one which I'd like to explore in its own right here in this column. All of the following

quotes are from my book *Comet of the Century* (Copernicus Books, 1996).

First night: Naked eye past Draco's head. "My search with binocs immediately produced a prominent ball of fuzzy light in its still imperceptibly slow roll past the head of the celestial dragon." When I first spotted Comet I-A-A, it was a roughly magnitude-4.9 object detectable with the naked eye, with a 15' patch of coma visible in a 6-inch telescope.

The circumpolar head of Draco doesn't get highest in the north until the middle of a May night but is already prominent in the northeast in the evening. The Dragon's head points toward ascending Vega and the Keystone of Hercules. It consists of stars of 2nd, 3rd, 4th, and 5th magnitude: Gamma (γ) Draconis (Eltanin), Beta (β) Draconis (Rastaban), Xi (ξ) Draconis (Grumium), and Nu (ν) Draconis (Kuma). Eltanin, at 2nd magnitude, is the orange eye of Draco. And 5th-magnitude Kuma is formed by equally bright white components a generous 62" apart.

Third night: A Great Orion Nebula in the body of Draco.

"Last torn cloud curtain edge was withdrawn to reveal a sky clean and sheer to about mag. 7.0 at its summit . . . and a handful of strong phosphorescence hung in mid-flight on that sky's north shoulder." The comet was in the long, twisting body of Draco, which wraps around the North Ecliptic Pole, near which glows NGC 6543, the wonderful 9th-magnitude Cat's Eye Nebula. But that night Comet I-A-A appeared larger and much brighter than M8, the Lagoon Nebula, like a detached piece of Milky Way, ". . . or at least for me in that magic clear dark — like another Orion Nebula in size, brightness and even shape!"

Fourth night: Flung from the Little Dipper's bowl.

At nightfall the comet's coma was already surrounding Kochab, Beta (β) Ursae Majoris. "It was fascinating viewing the rather bright star cloaked in that slight veil, and the conjunction of the comet's center with the star was surprisingly close." The comet was going so fast it only took minutes for it to move off of this underappreciated orange "Guardian of the Pole" that's very nearly as bright as Polaris. It was seemingly being flung, in one day, from the Little Dipper's bowl to just past the Big Dipper's bowl. I judged the comet to be magnitude 2.8 or 2.9 and 1° to $1\frac{1}{4}^\circ$ wide to the naked eye that night.

Sixth night: A huge, near-1st-magnitude comet passes M44.

The head of the comet was very close to the smaller, much dimmer patch of M44 (the magnitude-3.1 and $1\frac{1}{2}^\circ$ -wide Beehive Cluster). Comet authority John Bortle rated the comet's head as magnitude 1.7 and at least 2° wide that evening. Walter Scott Houston estimated the comet's head as an astounding 6° across! And, in a sky so dark and clear I could trace the zodiacal light bridge across it, I saw the two edges of the previously tailless comet's tail extending up to 15° long.

■ FRED SCHAAF saw his first naked-eye comet, Tago-Sato-Kosaka, in 1970 — just before seeing Comet Bennett.

To find out what's visible in the sky from your location, go to skypub.com/almanac.

The Planets Run the Show

No matter what time of night you turn your gaze skyward, you should spot a planet . . . or three.

Jupiter is at opposition this month, Saturn is at opposition in June, Mars in July — and then Venus is at greatest elongation in August: four months in a row of bright planets at their best.

May offers us Jupiter marching across the heavens at its most splendid from dusk to dawn. Even more brilliant Venus dominates the western heavens for the first few hours of the night. Before evening is quite over, the ringed planet Saturn comes up in the southeast. It's followed in the hour after local midnight by the rising of the brighter, fire-colored Mars, which again more than doubles in brightness in a single month.

ALL NIGHT LONG

Jupiter reaches opposition on the North American evening of May 8th. All month long, the planet shines at magnitude -2.5 and appears more than $44''$ across at its equator. See page 48 for information on when the Great Red Spot passes Jupiter's central meridian, and what's in store for the Galilean satellites. The grand planet continues to slowly retrograde (move west against the starry background) throughout the month. It appears 4° north of the excellent wide double star Alpha (α) Librae (also known as Zubenelgenubi) at the start of the month, and less than 1° from the double star at the end of the month.

EVENING

Venus still shines at -3.9 this month and grows only a little in angular diameter — from about $11\frac{1}{2}''$ to $13''$, while shrinking only a little in phase — from 89% to 80% illuminated. More favorable, and improving, is Venus's height. The glowing planet's sunset altitude for observers around latitude 40° north increases from about 24° to 27° in May. Venus sets more than $2\frac{1}{2}$ hours after the Sun by the end of May.

Aldebaran, the orange giant star in Taurus, is almost 100 times dimmer than Venus and hangs a minimum of 6.4° below the blazing planet on May 2nd. Venus glides on into Gemini on May 19th, and on the evenings of May

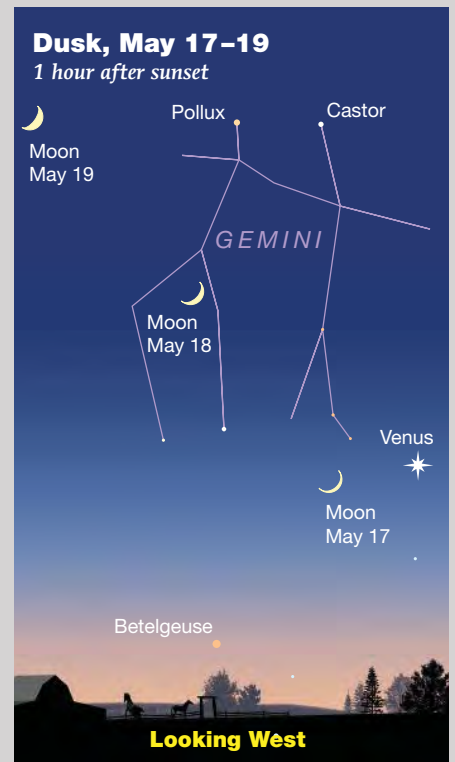
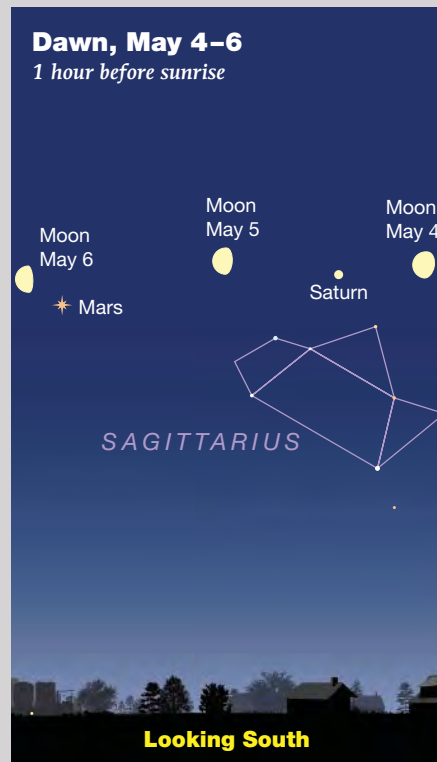

20th and 21st is only about 1° from the center of the big M35 star cluster.

LATE EVENING TO DAWN

Saturn comes up a little after midnight daylight-saving time on May 1st and about two hours earlier on May 31st. The ringed world floats less than 4° upper left of the top star of the Teapot of Sagittarius, Lambda (λ) Sagittarii. Saturn brightens from magnitude +0.3 to +0.2 in May, the month before its opposition. The apparent diameter of Saturn's globe grows slightly this month — up to over 18" wide by late May. Saturn is far south in the heavens this year, so we should seek the sharpest views of its globe and generously tilted rings when it's close to its highest for the night, which occurs around 5 a.m. in early May and a little before 3 a.m. at month's end.

MIDNIGHT TO DAWN

Mars continues its thrilling rapid increase in both brightness and size as Earth prepares to catch up to it at opposition in late July — the closest opposition of Mars in 15 years. On May 1st, the Red Planet bursts above

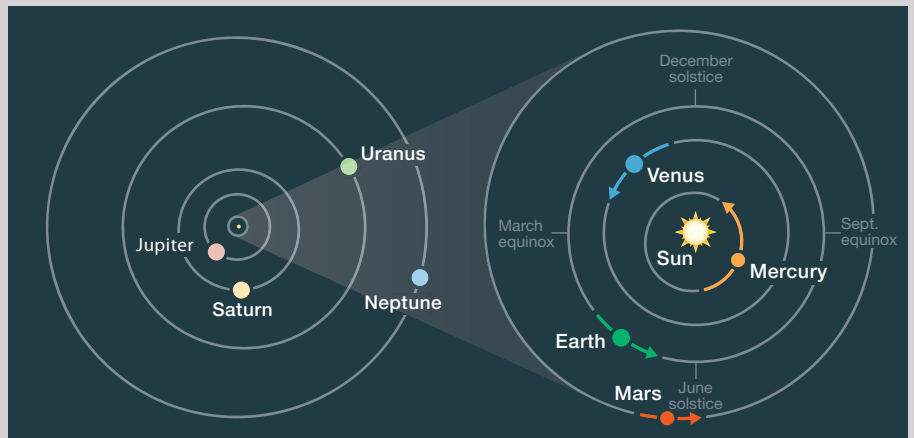

ORBITS OF THE PLANETS

The curved arrows show each planet's movement during May. The outer planets don't change position enough in a month to notice at this scale.

the east-southeast horizon for viewers at mid-northern latitudes a little before 1:30 a.m. local time — about the same time Jupiter is at its highest in the south. By May 31st, Mars rises a little after midnight. This most fascinating of Earth's fellow planets continues to move eastward with direct motion, passing from Sagittarius into Capricornus in mid-May.

How bright and big does Mars get this month? It flares from magnitude

-0.4 (slightly brighter than Arcturus) to a brilliant -1.2. Its apparent diameter swells from 11" to 15", opening up the season for seeing multiple Martian surface features on steady nights with telescopes as small as 6 inches. Spring begins on May 22nd for the southern hemisphere of Mars. The south polar ice cap, now shrinking, will be tilting into slightly better view in the months ahead.

DAWN

Mercury was at greatest elongation from the Sun on April 29th and remains out of view, too close to the Sun, during May. **Uranus** is 2.2° to the upper left of Mercury in the morning of May 13th, but too dim in the brightening dawn sky to observe. **Neptune** is already high enough by the start of morning twilight to be observed this month.

MOON PASSAGES

The waning gibbous **Moon** is slightly more than 5½° right or upper right of Saturn at dawn on May 4th and slightly more than 6½° to the left of Saturn (almost halfway between Saturn and Mars) at dawn on May 5th. The Moon forms an impressive sight with Mars just around 2° to its lower right in the hours leading up to dawn on May 6th. The waxing crescent Moon is some 6° to the left of Venus at nightfall on May 17th. The Moon is exactly at first quarter when it passes less than 1° above Regulus in Leo on the North American evening of May 21st. The almost-full Moon is just over 5° left of Jupiter on the evening of May 27th, and the waning gibbous Moon is a little more than 2° to the left of Saturn four days later.

■ Contributing Editor **FRED SCHAAF** has experienced a few of his clearest nights ever in early May.

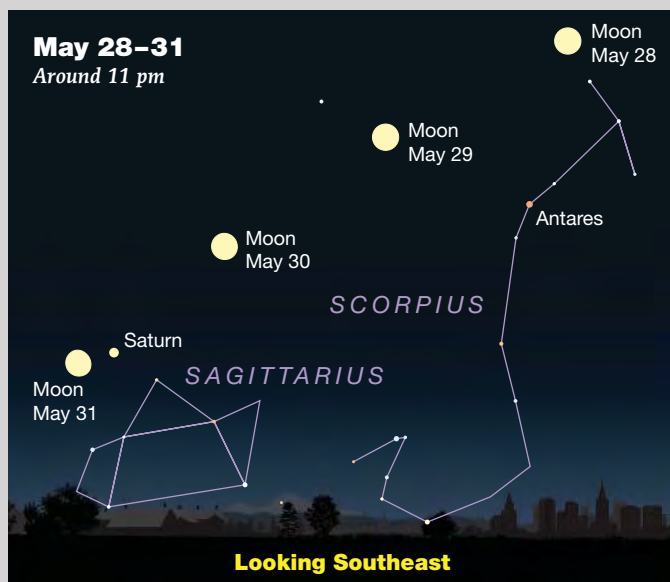

◀ These scenes are drawn for near the middle of North America (latitude 40° north, longitude 90° west); European observers should move each Moon symbol a quarter of the way toward the one for the previous date. In the Far East, move the Moon halfway. The blue 10° scale bar is about the width of your fist at arm's length. For clarity, the Moon is shown three times its actual apparent size.

Jupiter, By Jove!

The solar system's greatest gas giant puts in a bold appearance this month.

Jupiter spent spring creeping through the night. Just a few months ago, an audience with the monarch was an early morning pleasure, best taken care of before beginning the work day. Now, Jupiter appears with the dark, its rise coinciding with the setting of the Sun on May 8th, the date of opposition. Jupiter rises about two hours before sunset on the first evening of May and sets about an hour before the first sunrise of June, which means Jove is up the entire night this month, for all practical purposes. Even more important for visual observers: Jupiter is highest, and thus in the steadiest part of the sky, in the middle of the night. It transits about 1½ hours after midnight on May 1st and 45 minutes before midnight on the 31st. Altitude is essential for the best view of this gas giant; when Jupiter is up high, out of the haze above the horizon, you'll have the best shot at steady seeing (i.e., looking through less atmospheric turbulence).

Observing the Giant

Even in the steadiest part of the sky, good observations of planets happen a millisecond at a time. Improve your views by setting up your optics early in the evening to let them adjust to the ambient temperature. Then, when Jupiter rides high in the dark sky, focus in on the planet's edge and settle in for a good, long study session. The moments of absolute clarity are fleeting, and you'll find yourself instinctively testing your focus every now and again. It's good to check every once in a while, but patience is really your best tool here.

This color-enhanced image, taken as the spacecraft Juno flew by Jupiter on December 16, 2017, shows the intense storm patterns in the cloud bands of Jupiter's northern hemisphere.

Once you've found the planet and tested your focusing skills, increase the magnification. You'll find Jupiter goes a bit blurry pretty quickly. With my 5-inch, f/5 reflector, I stop trying for more by the time I hit 150×. The 10-inch f/4.5 reflector shows Jupiter at its best around 250× or so, though occasionally a bit more power is better. It's tricky to find the perfect balance of magnification and sharpness, but that's part of the observing fun.

If you're having difficulty distinguishing Jupiter's atmospheric features, add an appropriate filter to your setup. Over the years, I've found a #80A (blue) filter to be the most useful for "bumping" the contrast of the cloud bands, but #38A (dark blue) and #82A (light blue) may be better for you — try them all if you have them. Many observers find #8, #11, and #12 (yellow and yellow-green) filters help draw out details in the belts and polar regions. I sometimes screw on a #25 (red) filter for kicks and contrast, but usually return to a blue filter after a few minutes.

One of the neat things about Jupiter is that our view of it changes relatively quickly. A revolution takes just under 10 Earth hours, so if you observe early, then return to the planet later that night, you'll see a decidedly different picture. The diagram at the right shows Jupiter's main markings. Through a small scope, you should be able to see the two major cloud bands, the South and North Equatorial Belts. From there, it's a matter of spotting subtleties. Jupiter's *belts*, both equatorial and temperate, are slightly ruddy or beige in the eyepiece. They're separated by brighter, whiter bands called *zones*. Distinguishing white-ish zones from wheat-ish belts is a full night's work.

Within the zones and belts rage storms. Look for these *ovals*, tight gatherings of clouds that dot Jupiter's bands. White ovals, which often develop in the South Temperate Belt, can really "pop" in the eyepiece. Ovals can also be red, as in the Great Red Spot, or gray. *Barges* resemble compressed ovals; they're dark and red, but somewhat linear or blocky. Study the belts for variations in color caused by *rifts*, long, bright streaks that stretch along the darker bands. Readily apparent in images but more elusive to the eye are *festoons*, tendril-like blue-gray features that angle into zones from a belt.

The Great Red Spot

If you time your observing to coincide with the transit of the Great Red Spot (GRS), the changes on the planet's face become even more obvious. The GRS, which sits in a pocket between the South Equatorial Belt and the South Tropical Zone called "Red Spot Hollow," can be a challenge for observers with small scopes. Your best chance at seeing it is within an hour of the time it crosses the planet's central meridian. Here are those crossing times, in Universal Time, as predicted for April and May. The dates, also in UT, are in bold. (Eastern Daylight Time is UT minus 4 hours.) For more on the GRS, see page 52.

April 1, 0:11, 10:07, 20:02; **2**, 5:58, 15:54; **3**, 1:49, 11:45, 21:40; **4**, 7:36, 17:32; **5**, 3:27, 13:23, 23:18; **6**, 9:14, 19:10; **7**, 5:05, 15:01; **8**, 0:56, 10:52, 20:47; **9**, 6:43, 16:39; **10**, 2:34, 12:30, 22:25; **11**, 8:21, 18:17; **12**, 4:12, 14:08; **13**, 0:03, 9:59, 19:54; **14**, 5:50, 15:46; **15**, 1:41, 11:37, 21:32; **16**, 7:28, 17:24; **17**, 3:19, 13:15, 23:10; **18**, 9:06, 19:01; **19**, 4:57, 14:53; **20**, 0:48, 10:44, 20:39; **21**, 6:35, 16:31; **22**, 2:26, 12:22, 22:17; **23**, 8:13, 18:08; **24**, 4:04, 14:00, 23:55; **25**, 9:51, 19:46; **26**, 5:42, 15:37; **27**, 1:33, 11:29, 21:24; **28**, 7:20, 17:15; **29**, 3:11, 13:07, 23:02; **30**, 8:58, 18:53.

May 1, 4:49, 14:44; **2**, 0:40, 10:36, 20:31; **3**, 6:27, 16:22; **4**, 2:18, 12:14, 22:09; **5**, 8:05, 8:00; **6**, 3:56, 13:51, 23:47; **7**, 9:43, 19:38; **8**, 5:34, 15:29; **9**, 1:25, 11:21, 21:16; **10**, 7:12, 17:07; **11**, 3:03, 12:59, 22:54; **12**, 8:50, 18:45; **13**, 4:41, 14:37; **14**, 0:32, 10:28, 20:23; **15**, 6:19, 16:14; **16**, 2:10, 12:06, 22:01; **17**, 7:57, 17:52; **18**, 3:48, 13:44, 23:39; **19**, 9:35, 19:30; **20**, 5:26, 15:22; **21**, 1:17, 11:13, 21:08; **22**, 7:04, 17:00; **23**, 2:55, 12:51,

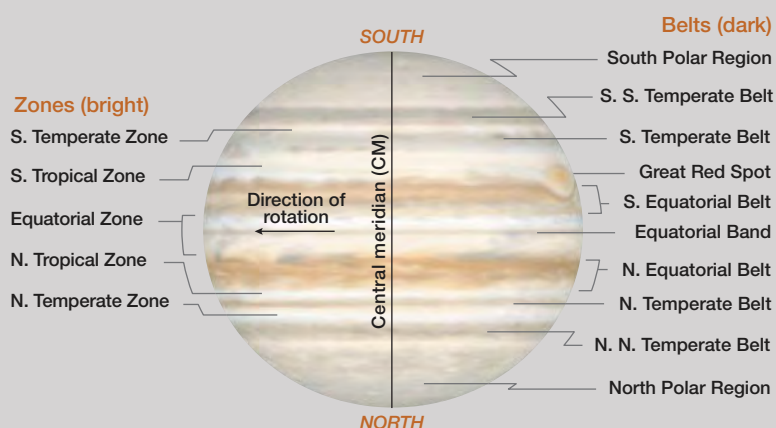

▲ The features of Jupiter change in intensity, size, and position over time; this basic schema should help you identify what you see in your eyepiece. South is up to match the view in many telescopes. Features rotate from celestial east to west.

22:47; **24**, 8:42, 18:38; **25**, 4:33, 14:29; **26**, 0:25, 10:20, 20:16; **27**, 6:11, 16:07; **28**, 2:03, 11:58, 21:54; **29**, 7:50, 17:45; **30**, 3:41, 13:36, 23:32; **31**, 9:28, 19:23.

These times assume that the spot will be centered at System II longitude 288°. If the Red Spot has moved elsewhere, it will transit 1½ minutes earlier for each degree less than 288° and 1½ minutes later for each degree more than 288°.

Jupiter's Moons

Jupiter at opposition means the planet is at its boldest and brightest for the year, but so too are its Galilean moons. With close observing and the right equipment, you can detect differences in their sizes and colors (Io gives itself away with its orange-yellow appearance, Ganymede is the largest of the four). At opposition, Europa will appear the smallest, with a diameter of 1.0". Io will show at 1.1", Callisto at 1.5", and Ganymede will boast a whopping 1.7" diameter. Yes, these are tiny differences, but after enough repeat visits to the quartet, you'll be able to distinguish them from one another with ease.

If you need help, use the diagram on page 50 to identify Jupiter's moons at any date and time. All of the May interactions between Jupiter and its satellites and their shadows are tabulated on page 50.

Take the time to make a sketch, keeping in mind that a polished drawing isn't necessarily the goal. Rather, it's the process of looking while you're



▲ Using a 1-meter Ritchey-Chrétien telescope, Damian Peach captured the shadow of Ganymede (top left) as it traveled across the face of Jupiter in March 2017. Golden Io gleams to the right of the planet.

Jupiter's Moons

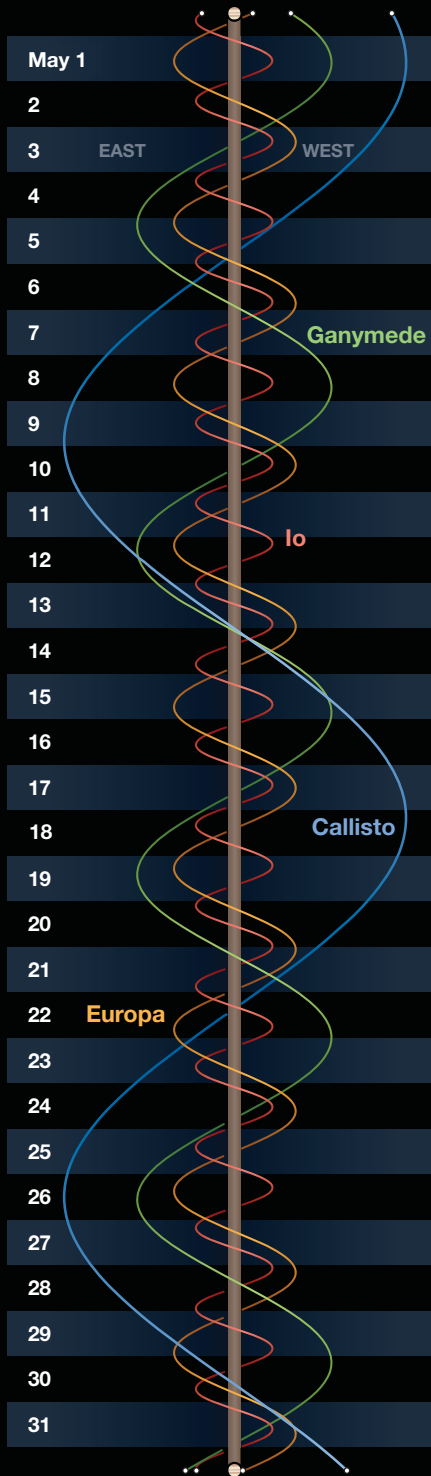

The wavy lines represent Jupiter's four big satellites. The central vertical band is Jupiter itself. Each gray or black horizontal band is one day, from 0^h (upper edge of band) to 24^h UT (GMT). UT dates are at left. Slide a paper's edge down to your date and time, and read across to see the satellites' positions east or west of Jupiter.

recording the view that will help you learn the planet. Don't worry about your cramped handwriting or inability to replicate the subtle bands of Jupiter's globe on the page. Even a "sketch in prose" can be useful: What color are the equatorial belts? Can you see any texture in them? Did you see the Great

Red Spot? How were the planet's satellites positioned? Anything that helps you remember those brilliant moments of perfect seeing is good enough to put on paper. My best advice: If you think it, write it down, because you're unlikely to remember that thought or impression after a short night's sleep.

Phenomena of Jupiter's Moons, May 2018

May 1	1:02 I.Sh.I	2:14 I.Ec.R	23:08 I.Tr.I	20:59 III.Ec.R
2	1:14 I.Tr.I	11:20 II.Sh.I	23:19 I.Sh.I	21:59 I.Oc.D
3	3:12 I.Sh.E	11:22 II.Tr.I	1:16 I.Tr.E	0:31 I.Ec.R
4	3:23 I.Tr.E	13:31 II.Tr.E	1:29 I.Sh.E	10:56 II.Oc.D
5	22:10 I.Ec.D	13:36 II.Sh.E	14:38 III.Oc.D	13:56 II.Ec.R
6		21:24 I.Tr.I	17:00 III.Ec.R	19:18 I.Tr.I
7	0:29 I.Oc.R	21:25 I.Sh.I	20:14 I.Oc.D	19:42 I.Sh.I
8	8:45 II.Sh.I	23:32 I.Tr.E	22:37 I.Ec.R	21:27 I.Tr.E
9	9:08 II.Tr.I	23:35 I.Sh.E		21:51 I.Sh.E
10	11:01 II.Sh.E		May 17	
11	11:16 II.Tr.E	May 10	8:41 II.Oc.D	May 25
12	19:31 I.Sh.I	11:15 III.Ec.D	11:21 II.Ec.R	16:25 I.Oc.D
13	19:40 I.Tr.I	13:01 III.Ec.R	17:34 I.Tr.I	19:00 I.Ec.R
14	21:41 I.Sh.E	18:30 I.Oc.D	17:47 I.Sh.I	May 26
15	21:49 I.Tr.E	20:42 I.Ec.R	19:42 I.Tr.E	May 27
16			19:57 I.Sh.E	5:00 II.Tr.I
17	7:17 III.Ec.D	May 11		5:50 II.Sh.I
18	9:18 III.Oc.R	6:26 II.Oc.D	May 18	7:11 II.Tr.E
19	16:38 I.Ec.D	8:46 II.Ec.R	8:41 II.Oc.D	8:06 II.Sh.E
20	18:55 I.Oc.R	15:50 I.Tr.I	14:40 I.Oc.D	13:44 I.Tr.I
21	3:55 II.Ec.D	15:53 I.Sh.I	17:05 I.Ec.R	14:10 I.Sh.I
22	6:22 II.Oc.R	17:58 I.Tr.E		15:53 I.Tr.E
23	13:59 I.Sh.I	18:03 I.Sh.E	May 19	16:20 I.Sh.E
24	14:06 I.Tr.I		2:44 II.Tr.I	May 28
25	16:09 I.Sh.E	May 12	3:14 II.Sh.I	7:23 III.Tr.I
26	16:15 I.Tr.E	12:56 I.Oc.D	4:55 II.Tr.E	8:47 III.Tr.E
27		15:11 I.Ec.R	5:30 II.Sh.E	9:04 III.Sh.I
28	11:07 I.Ec.D	May 13	12:00 I.Tr.I	10:48 III.Sh.E
29	13:21 I.Oc.R	0:29 II.Tr.I	12:16 I.Sh.I	10:51 I.Oc.D
30	22:03 II.Sh.I	0:38 II.Sh.I	14:08 I.Tr.E	13:28 I.Ec.R
31	22:15 II.Tr.I	2:39 II.Tr.E	14:26 I.Sh.E	
		2:54 II.Sh.E		May 29
		10:16 I.Tr.I	May 21	0:03 II.Oc.D
		10:22 I.Sh.I	4:07 III.Tr.I	3:13 II.Ec.R
		12:24 I.Tr.E	5:05 III.Sh.I	8:11 I.Tr.I
		12:32 I.Sh.E	5:26 III.Tr.E	8:39 I.Sh.I
May 6	0:19 II.Sh.E		6:50 III.Sh.E	10:19 I.Tr.E
	0:24 II.Tr.E	May 14	9:06 I.Oc.D	10:48 I.Sh.E
	8:28 I.Sh.I	0:53 III.Tr.I	11:34 I.Ec.R	
	8:32 I.Tr.I	1:07 III.Sh.I	21:48 II.Oc.D	May 30
	10:38 I.Sh.E	2:07 III.Tr.E		5:17 I.Oc.D
	10:41 I.Tr.E	2:52 III.Sh.E	May 22	7:57 I.Ec.R
	21:09 III.Sh.I	7:22 I.Oc.D	0:39 II.Ec.R	18:08 II.Tr.I
	21:39 III.Tr.I	9:39 I.Ec.R	6:26 I.Tr.I	19:08 II.Sh.I
	22:49 III.Tr.E	19:34 II.Oc.D	6:44 I.Sh.I	20:20 II.Tr.E
	22:53 III.Sh.E	22:04 II.Ec.R	8:35 I.Tr.E	21:24 II.Sh.E
			8:54 I.Sh.E	
May 7	5:35 I.Ec.D	May 15		May 31
	7:47 I.Oc.R	4:42 I.Tr.I	May 23	2:37 I.Tr.I
	17:13 II.Ec.D	4:50 I.Sh.I	3:32 I.Oc.D	3:07 I.Sh.I
	19:29 II.Oc.R	6:50 I.Tr.E	6:02 I.Ec.R	4:46 I.Tr.E
		7:00 I.Sh.E	15:52 II.Tr.I	5:17 I.Sh.E
May 8	2:56 I.Sh.I	May 16	16:32 II.Sh.I	21:11 III.Oc.D
	2:58 I.Tr.I	1:48 I.Oc.D	18:03 II.Tr.E	22:39 III.Oc.R
	5:06 I.Sh.E	4:08 I.Ec.R	18:47 II.Sh.E	23:12 III.Ec.D
	5:07 I.Tr.E	13:37 II.Tr.I		23:44 I.Oc.D
		13:56 II.Sh.I	May 24	
May 9	0:04 I.Ec.D	15:47 II.Tr.E	0:52 I.Tr.I	
		16:12 II.Sh.E	1:13 I.Sh.I	
			3:01 I.Tr.E	
			3:23 I.Sh.E	
			17:54 III.Oc.D	

Every day, interesting events happen between Jupiter's satellites and the planet's disk or shadow. The first columns give the date and mid-time of the event, in Universal Time (which is 4 hours ahead of Eastern Daylight Time). Next is the satellite involved: I for Io, II Europa, III Ganymede, or IV Callisto. Next is the type of event: **Oc** for an occultation of the satellite behind Jupiter's limb, **Ec** for an eclipse by Jupiter's shadow, **Tr** for a transit across the planet's face, or **Sh** for the satellite casting its own shadow onto Jupiter. An occultation or eclipse begins when the satellite disappears (**D**) and ends when it reappears (**R**). A transit or shadow passage begins at ingress (**I**) and ends at egress (**E**). Each event is gradual, taking up to several minutes. Predictions courtesy IMCCE / Paris Observatory.

Count the Eta Aquariids?

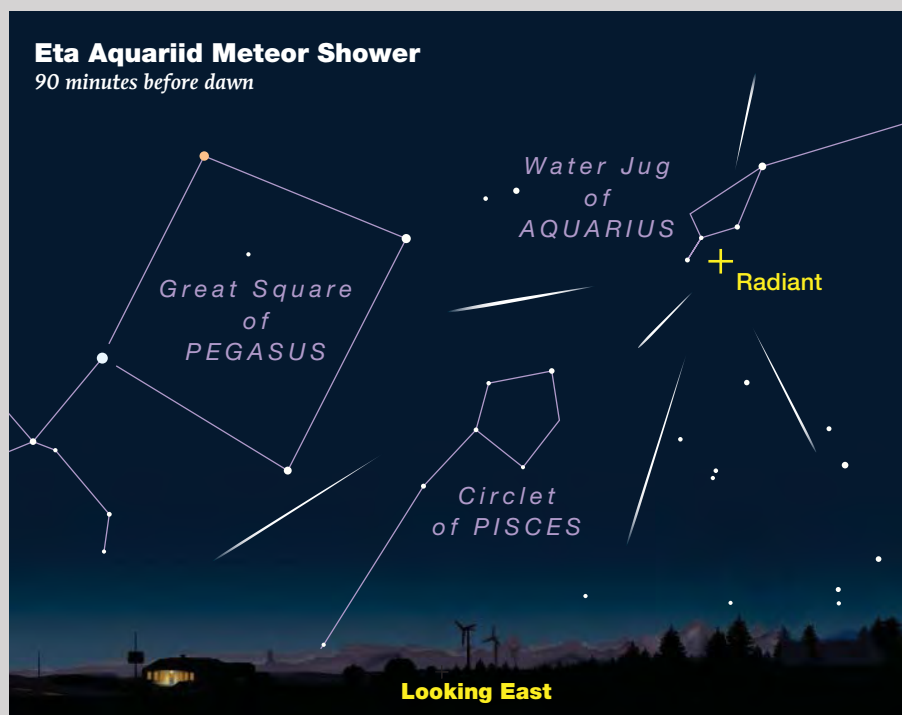

▲ From latitude 30° north about 90 minutes before sunset, the radiant for the Eta Aquariid meteor shower rides low in the sky. For observers farther north, the radiant rises later, so is even lower when the sky begins to lighten.

MOONLIGHT WILL AFFECT visual observations of this year's Eta Aquariid meteors. The shower is usually one of the best of the year for the Southern Hemisphere. For viewers at more northerly latitudes, the radiant is above the horizon for just a few hours before dawn. Subsequently, the shower often produces long, fast meteors along the eastern horizon as morning twilight begins — that is, when the Moon doesn't get in the way.

This year's peak is predicted to fall on May 6th, which means that it coincides with a waning gibbous Moon, not ideal lighting conditions. Even so, the International Meteor Organization (IMO) recommends that observers get out and record this year's shower activity. Research prompted by J. Hutch Kinsman's and David Asher's inquiry into meteor showers during the Maya Classic period (see *S&T*: April 2018, p. 36) indicates that there may be a slight enhancement of activity on May

3rd due the gravitational influence of Jupiter on the 164 BC trail of the parent object, Comet 1P/Halley. A similar bump may occur on May 5th, thanks to Jupiter's influence on Halley's AD 218 trail.

If you're interested in doing a scientific meteor count, you'll need to commit to at least one hour of observing and follow a standardized method. This involves determining the faintest stars you can see with your naked eye from your location, as well as recording your latitude and longitude. Note the time, and keep track of the times you looked away from the sky. Ideally, you should watch in a direction free of interference by trees and artificial lights, and in a direction away from the Moon.

Visit imo.net for more instructions on how to report your count.

● **FIND YOUR CLUB:**
skyandtelescope.com/astronomy-clubs-organizations.

Asteroid Occultations

IN THE EARLY MORNING hours of May 11th, the asteroid **472 Roma** will occult a 10.8-magnitude star in Serpens Caput. Observers along a path that stretches from the West Coast to the South Atlantic region will see the star's brightness drop 2.4 magnitudes for up to 4.2 seconds.

The International Occultation Timing Organization (IOTA) notes that Roma was well observed during an occultation on July 8, 2010, but because the star occulted had an angular size of about $\frac{1}{3}$ that of the asteroid, it was difficult to completely determine Roma's size and shape.

For observers in Redding, California, the event should begin within a minute or two of 8^h 14^m UT (1:14 a.m. PDT). Observers near Oklahoma City can expect it to begin near 8^h 10^m UT (3:10 a.m. CDT). And near Savannah, Georgia, look for the occultation to occur within a minute or so of 8^h 08^m UT (4:08 a.m. EDT).

On the night of May 21–22, the 88-km-wide main-belt asteroid **201 Penelope** will temporarily dim the light of a 9.9-magnitude star in Virgo. Observers along a path that crosses the western United States and Central America will see the star appear to drop to 13.7, the magnitude of Penelope. The event could last as long as 40 seconds. This long period of asteroid interference centers on 5^h 22^m UT.

Analyses of Penelope's spectra suggest that it's an M-type, or metallic, asteroid. Could its composition mean that it's the leftover core of a larger, now-destroyed asteroid? More observations will help pin down the details of Penelope's faceted form.

About a week before both events, more precise predictions and path maps will be available from Steve Preston's minor-planet occultation website (asteroidoccultation.com). For advice on timing occultations and reporting observations, see asteroidoccultation.com/observations.

Spotting Jupiter's Spot

Timing is everything when it comes to glimpsing the iconic Great Red Spot. Steady seeing helps too.



▲ The seeing was nearly perfect on May 19, 2017, when veteran planetary photographer Christopher Go captured the Great Red Spot marching across Jupiter's disk. The date was six weeks after the planet's opposition, and he recorded the images with a 14-inch telescope over a span of 52 minutes. South is up.

Ask your astronomically curious friends to name a famous feature on another planet, and the top choice will almost certainly be “Saturn's rings.” A strong runner-up will likely be Jupiter's Great Red Spot. Yet while most casual telescope users have gazed upon those glorious rings many times, far fewer have ever spied Jupiter's iconic GRS. So for those of you longing for your first glimpse of it — or just wanting another look — read on!

This year Jupiter comes to opposition on the night of May 8–9. That's when this giant planet will appear its biggest (45 arcseconds across) and brightest (magnitude -2.5), and it'll be nearly as big and bright for several weeks before or after this date.

Yet it's not an especially favorable opposition. For example, at the one in September 2010, Jupiter swelled to 50 arcseconds and magnitude -2.9 (nearly 50% brighter). Also, Jupiter's southern declination (-16°) this year means the planet never climbs very high in the sky for most northern observers.

The GRS itself — an enormous, high-pressure (anticyclonic) “storm” rotating every 6 days — has undergone a modest metamorphosis of late. If you haven't looked for the spot in the past decade, you'll be surprised by how much it's changed in the intervening years.

Shrinking and Shifting

In *S&T*'s March 2016 issue, atmospheric specialist Amy Simon (NASA Goddard Space Flight Center) describes how the GRS has gradually gotten smaller ever since telescopic observers made the first reliable measurements of its size in the

1880s. A century ago, for example, the Great Red Spot was $2\frac{1}{2}$ times longer than it is now.

However, as Simon and her colleagues detail in a forthcoming *Astronomical Journal* article, the rate of that shrinking accelerated by about 50% beginning about 1979, the year that Voyagers 1 and 2 made their historic flybys of Jupiter.

Today the GRS's longitudinal length is just 13.7° , or about 15,500 km (9,600 miles) across. The width has shrunk too, down to just under 10° in latitude (12,000 km). It's still bigger than Earth — but not by much.

Meanwhile, the spot doesn't stay put. It's sandwiched at latitude $22\frac{1}{2}^\circ$ south between a strong, westward-flowing jet stream to its north and an equally strong eastward jet to its south. The GRS spins counterclockwise like a giant ball bearing rolling between them, creating an oversize obstacle that deflects the jets as they flow past.

A little background: Jupiter rotates *differentially*. Its deep interior spins once every 9.925 hours ($9^h 55^m 30^s$), at what's called its System III rotation period. But the cloudtops within 10° of the equator zip around 5 minutes *faster* (System I) — while at the GRS's latitude, the mean rotation period (System II) is about 11 seconds *slower*.

Observers had long thought that the GRS spun around Jupiter at the System II rate, but it's actually lagging behind and gradually drifting westward with respect to all the cloud features around it. Simon and her team find that the GRS's westward drift has also accelerated in recent years, and they're strug-

gling to understand the steering forces that could be causing it to move faster.

“The biggest factor is the surrounding winds,” she explains, perhaps due to very slight changes in the latitudes of the adjacent zonal jets. But the effect is hard to measure since the GRS deflects those same winds. And the spot can be buffeted by disturbances that churn up the jets and other effects. “We have hints,” Simon says, “but nothing has been conclusive.”

The good news in all of this morphing is that the Red Spot has gotten redder and darker over the past decade. (Historically, the spot’s color seems to intensify when its westward drift accelerates.) The cause of the darkening isn’t clear, but Simon suspects it has to do with conservation of angular momentum. As the spot shrinks, its internal circulation should speed up — but it hasn’t. Instead, the swirling gas might be forced to go to higher altitudes (and there’s evidence this is occurring), where lower pressures and temperatures might be driving “colorful” chemical reactions.

The exact chemical compound responsible for the spot’s ruddy hue is still unknown. Some candidates, like red phosphorous derived from phosphine (PH_3), aren’t wholly consistent with the chemical makeup of the Jovian atmosphere. In 2016 Robert Carlson (Jet Propulsion Laboratory) and others suggested that the colorant results from the reaction of ammonia (NH_3) and acetylene (C_2H_2). Recently a team led by Lawrence Sromovsky (University of Wisconsin at Madison) argued that this same compound could explain the

hues of many other Jovian cloud features.

Timing Is Everything

Chemistry aside, the Red Spot’s now-deeper color makes this a great time to try to spot it. But don’t just dash outside with your scope — a little preparation is called for.

Most critically, you’ll need to know when the GRS is front and center on Jupiter’s rapidly spinning globe. Look at the table on page 49 that lists when the spot crosses the planet’s *central meridian* (the north-south line through its poles). Don’t forget to convert those values from Universal Time to your local time zone. Plan to look within an hour of a listed time — otherwise the spot will be close to the planet’s limb and difficult to identify.

Ideally, choose a meridian-crossing time that occurs when Jupiter is high in your sky. You’ll always see less detail when the planet is close to the horizon, both because of atmospheric turbulence along your line of sight and also due to the thick air’s prism-like dispersion of color in Jupiter’s disk.

Next, use the Red Spot’s color to your advantage. A blue or green filter will make it stand out more readily from the surrounding clouds.

Finally, make sure your telescope is big enough. *S&T*’s Sean Walker suggests that you’ll need at least 4 inches



July 1994



July 2017

◀ These violet-filtered Hubble images accentuate the dramatic change in the GRS’s size and interior structure over a 23-year period.

(100 mm) of aperture to spot the GRS reliably, at least when observing from mid-northern latitudes. David Arditto (British Astronomical Association) adds, “For more experienced observers I have little doubt that a 75-mm refractor would be enough, under typical conditions, with a magni-

fication of 80×.”

Former *S&T* editor Tony Flanders notes that the task will be much easier if the atmosphere is stable. “I find the variation in visibility from night to night due to seeing swamps the variations depending on the GRS’s appearance,” he cautions. “On a half-decent night, it should be prominent in a good 4-inch refractor or 6-inch reflector.”

In fact, if you have two scopes, try setting them up side by side at comparable magnifications to see which one most easily coaxes the GRS into view. And if the spot itself isn’t apparent, look for the “Red Spot Hollow,” a bright indentation that the spot makes in the broad, dark South Equatorial Belt to its immediate north.

■ **KELLY BEATTY** plans to be on the lookout for the Great Red Spot all summer long.



April 2014

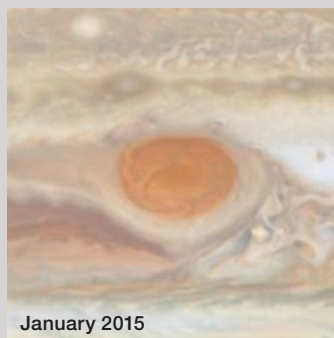

January 2015

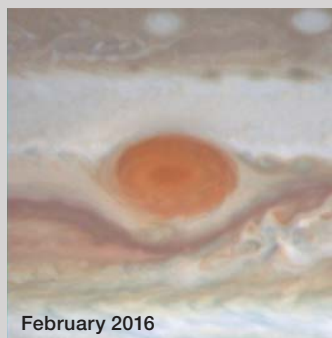

February 2016

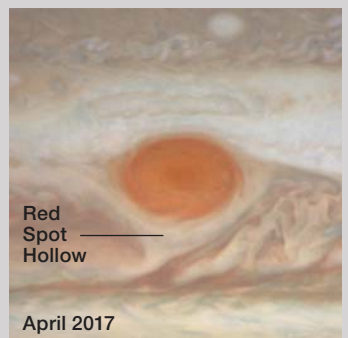

Red Spot Hollow

April 2017

▲ Natural-color Hubble Space Telescope images show how the Great Red Spot’s color has darkened and deepened since 2014. The spot creates pronounced turbulence in the westward flow of the South Equatorial Belt (lower right in each image).

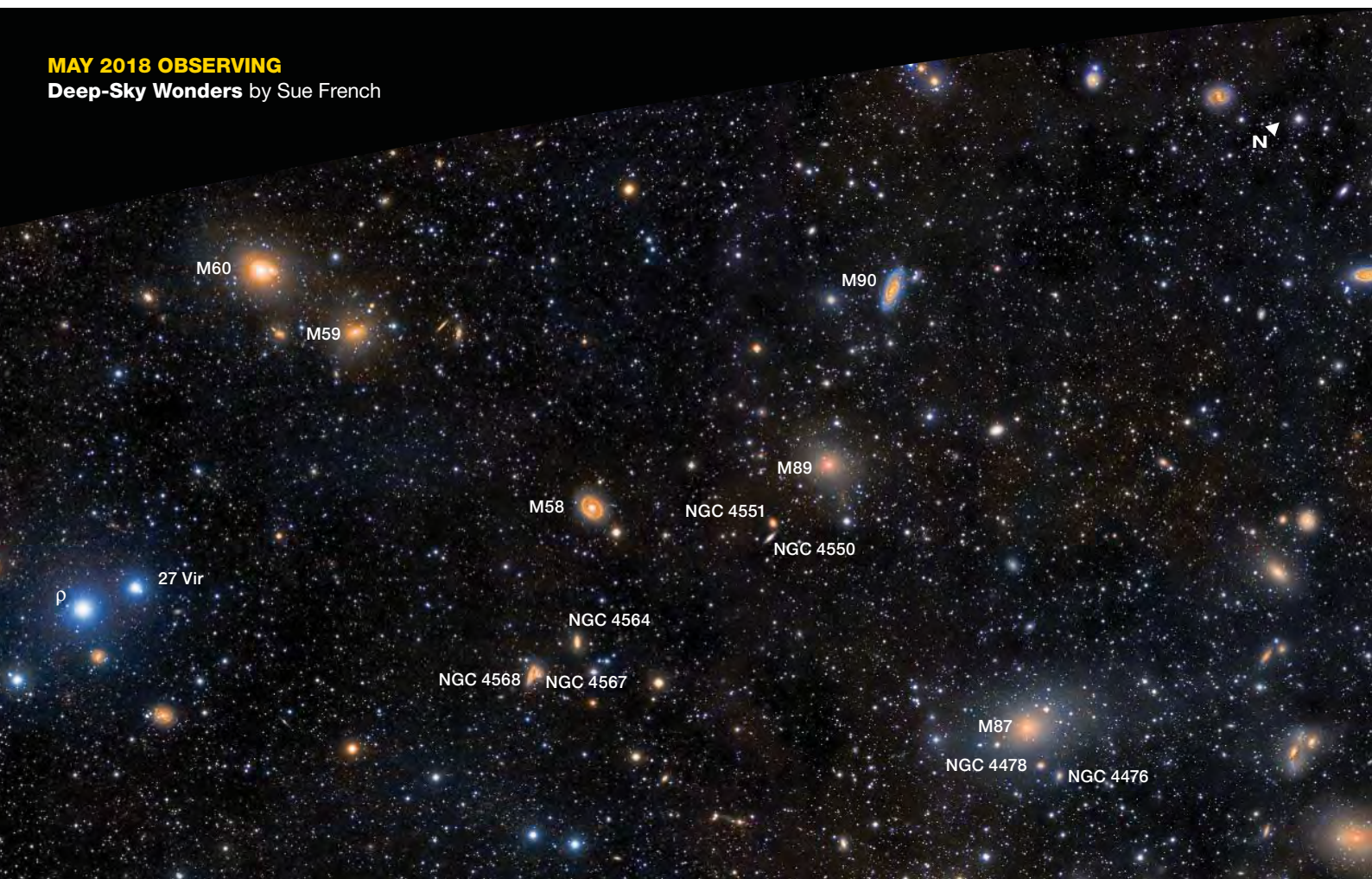

The Star-Clad Maiden

Visit Virgo to find these exemplary galaxies of spring.

*Would you the star of Bacchus find,
on noble Virgo's wing,
A lengthy ray from Hydra's heart
unto Arcturus bring;
Two-thirds along that fancied line,
direct th' inquiring eye,
And there the jewel will be seen,
south of Cor Caroli.*

— William Henry Smyth,
The Bedford Catalogue, 1844

This charming quatrain tells us how to find the star Vindemiatrix in Virgo using the Alpha stars of Hydra, Boötes, and Canes Venatici as guides. The tie between Virgo and the Roman god Bacchus (Greek Dionysus) has many versions, but a woeful tale is told by Julius D. W. Staal in his wonder-

ful book *The New Patterns in the Sky*. Bacchus taught Icarius, a mortal man, the art of winemaking. Icarius shared his newly created libation with friends and local shepherds, who mistook their intoxication for attempted poisoning and slew poor Icarius. His body, tossed aside in a ditch, was found by his faithful dogs and his daughter Erigone. In their grief, they followed him into death. Icarius was then placed in our sky as Boötes, his dogs as Canes Venatici, and Erigone as Virgo.

The area of the sky we'll be visiting lies west of Vindemiatrix and within the Virgo Cluster, which hosts about 1,500 galaxies. The cluster's main body is centered on the hefty galaxy **Messier 87**, sitting 54 million light-years away from

us. Including dark matter, M87 weighs in at roughly 10 trillion solar masses or around 10 Milky Way galaxies.

Through my 130-mm refractor at 23×, M87 is an obvious glow just south of a deep-yellow, 8.6-magnitude star. It appears slightly oval at 63× and brightens considerably toward the center. Examined at 117×, M87's brightness contours become rounder as you approach the center, and they enfold a small, brilliant core. The halo has indefinite boundaries, but I'd put the size at about 4½'. Nearby **NGC 4478** is also visible, looking fainter and more obviously oval than M87. Its plump profile tilts northwest and is roughly 1' long. While gazing at NGC 4478, I noticed **NGC**

▲ This deep image of the Virgo cluster represents more than 36 hours of exposure time. One easy route to the galaxy cluster hops from Epsilon (ε) Virginis (Vindemiatrix) to Rho and 27 Virginis. From those stars, it takes just a nudge to bring the galaxies into the field of view.

4476 with averted vision. It's a bit smaller but more elongated than NGC 4478, leaning north-northeast, and too faint to disclose any details. NGC 4478 and NGC 4476 delineate the top of an 8.2'-tall trapezoid that they form with two 11th-magnitude stars to their south-southwest.

My 10-inch reflector at 187× shows M87's 5'-long face cocked north-northwest. The interior is bright to a diameter of approximately 2½', and it grows much brighter toward the center. NGC 4478 is easy to spot, covering about 1¼'. Its fairly bright core intensifies inward to a tiny nucleus. NGC 4476 shows well now, brightening slightly toward an elusive nucleus.

M87 is famous for its narrow plasma jet, which is powered by the accretion disk around the galaxy's central, supermassive black hole. It's not surprising that amateur astronomers would love to see this beast, but it's quite astonishing that many have succeeded. This isn't an undertaking for the faint of heart. Those who have succeeded are accomplished observers working under excellent skies and using magnifications of about 400×. Most utilized 20-inch and larger telescopes, but some triumphed with scopes as small as 12½ inches in aperture. From the heart of the galaxy, the jet strikes out west-northwest for about 21", but the part that is most likely to be visible is the stretch from 12" to 18". If you decide to attempt this feat, be careful not to mistake the extremely faint galaxy pair (UGC 7652) 2' southwest of M87 for the jet.

Placing M87 in the western side of the 130-mm scope's 23× field of view brings **Messier 89** into view, looking smaller than M87 and round with a bright center. At 63× M89 displays a moderately faint halo, a brighter interior, and a small, intense core — all round. Boosting the magnification to 117×, the scope teases out a starlike

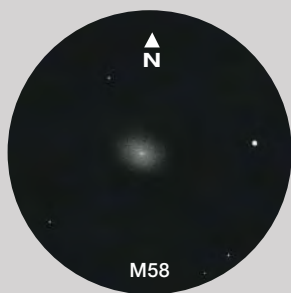

▲ Under very high power, the irregular structure of the barred spiral M58 may be revealed. The typical view through an 8-inch reflector is shown here. The galaxy is tipped slightly toward the east-northeast and appears brighter at its core.

nucleus. The galaxy's halo fades into the background sky at a diameter of about 2'. My 10-inch scope at 166× reveals a 13th-magnitude star watching over the halo's east-northeastern edge.

On deep images, M89 sports what appears to be a jet that extends a whopping 10' from the galaxy's center. However, this "jet" is composed of stars and may be the product of an encounter with a smaller galaxy.

Only 20' south of M89, we find the galaxy pair **NGC 4550** and **NGC 4551**. In a 1992 *Astrophysical Journal* paper, Vera Rubin and colleagues published an amazing find. Rubin later commented, "I discovered from observations of NGC 4550 that in the single disk of this galaxy, half the stars orbit clockwise, and half the stars orbit counterclockwise, both systems intermingled. This observation required that many astronomers modify the manner in which they measured velocities, for computer programs were not then equipped to handle such complexity. A nice discovery to make at age 63!" Few galaxies are known to

have such a large dichotomy, a feature that might be due to the merger of two galaxies with misaligned spins.

With a wide-angle eyepiece that gives 117× in the 130-mm scope, NGC 4550 and NGC 4551 share the field of view with M89. The very faint, 1½'-long, north-south spindle of NGC 4550 is enclosed in a trapezoidal box of four stars, magnitudes 12 and 13. The box is 5½' tall, with the galaxy just beneath (west of) its lid. Dimmer and vaguely

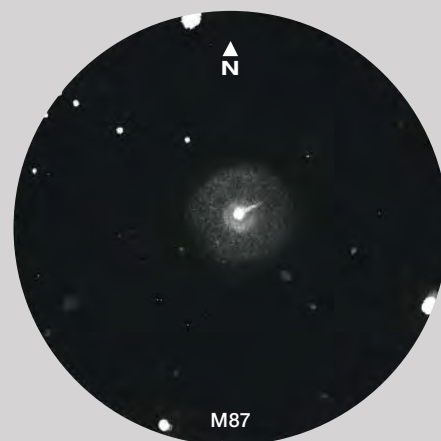

▲ With the right equipment, you may be able to detect the high-energy jet of particles emanating from M87's supermassive black hole. This sketch represents the plasma stream as viewed with a 20-inch Newtonian reflector and deep-sky video camera.

Galaxies in Virgo

Object	Type	Mag(v)	Surface Brightness	Size/Sep	RA	Dec.
M87	Giant elliptical	8.6	13.0	8.3' × 6.6'	12 ^h 30.8 ^m	+12° 23'
NGC 4478	Elliptical	11.5	12.6	1.9' × 1.6'	12 ^h 30.3 ^m	+12° 20'
NGC 4476	Lenticular	12.2	12.8	1.7' × 1.1'	12 ^h 30.0 ^m	+12° 21'
M89	Elliptical	9.8	12.5	5.1' × 4.7'	12 ^h 35.7 ^m	+12° 33'
NGC 4550	Barred lenticular	11.7	12.7	2.9' × 0.8'	12 ^h 35.5 ^m	+12° 13'
NGC 4551	Elliptical	12.0	13.0	1.8' × 1.4'	12 ^h 35.6 ^m	+12° 16'
M58	Barred spiral	9.7	13.1	5.9' × 4.7'	12 ^h 37.7 ^m	+11° 49'
NGC 4564	Elliptical	11.1	12.9	3.5' × 1.5'	12 ^h 36.5 ^m	+11° 26'
NGC 4567	Spiral	11.3	13.1	3.0' × 1.4'	12 ^h 36.5 ^m	+11° 15'
NGC 4568	Spiral	10.8	13.1	4.3' × 1.0'	12 ^h 36.6 ^m	+11° 14'

Angular sizes and separations are from recent catalogs. Visually, an object's size is often smaller than the cataloged value and varies according to the aperture and magnification of the viewing instrument. Right ascension and declination are for equinox 2000.0.

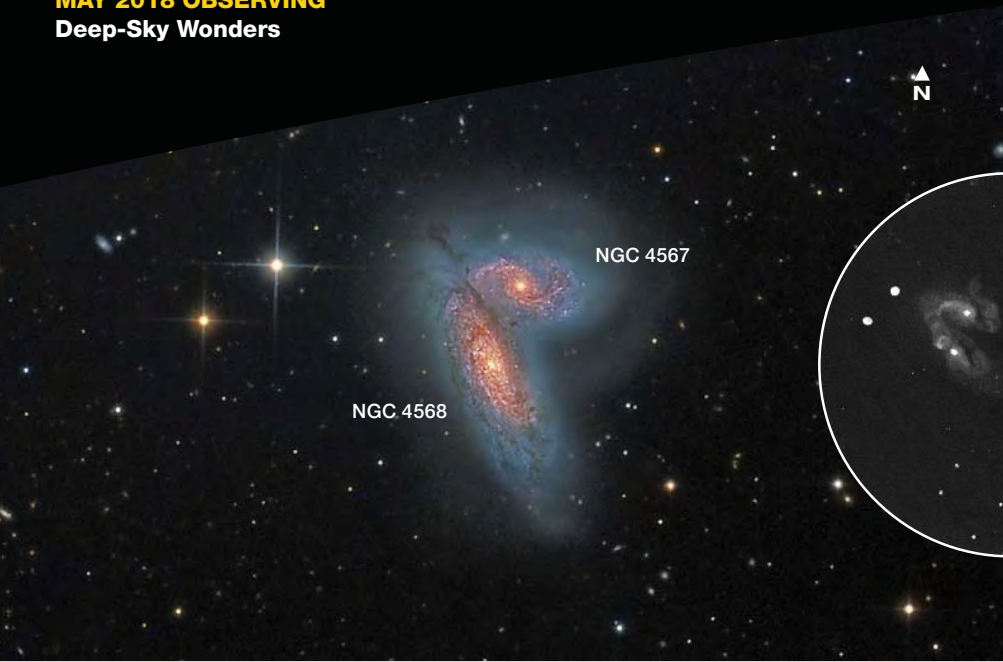

halo. My 10-inch reflector highlights a bar-like core. M58's blazing nucleus is powered by a supermassive black hole (weighing in at 50 to 70 million solar masses) fed by an accretion disk of infalling matter.

Three additional galaxies are visible in the refractor's low-power field. Although they are fairly faint, **NGC 4564**, **NGC 4567**, and **NGC 4568** were spotted without specifically looking for them. The last two blend together as one glow that's brighter and chubbier than NGC 4564. At 117× NGC 4564 displays a brighter, elongated interior and a small, radiant core. The faint halo is about 2' long and less than half as wide. Even at 164× the dual nature of NGC 4567/4568 isn't clear, but the combo's subtly wider north end and two fugitive, marginally brighter patches hint at the possibility.

The NGC 4567/4568 galaxies are well distinguished in the 10-inch scope at 115×, each galaxy holding a somewhat brighter, elongated interior. NGC 4568 is about 3' × 1', tipped north-northeast, and harbors a tiny nucleus. NGC 4567's oval spans 2¼', tilts a bit north of east, and embraces a small, brighter core. The halos of the galaxies merge at the eastern end of NGC 4567, which earns this pair its nickname, the Siamese Twins. The name was coined by Leland S. Copeland, the first Deep-Sky Wonders columnist, and introduced in the May 1946 issue of *Sky & Telescope*.

Because they look relatively undisturbed in the eyepiece and deep-sky images, the Siamese Twins were once thought to be a coincidental superposition of two unrelated galaxies. However, recent studies of their molecular gases have found telltale signs indicating the galaxies are in the early stages of gravitational and tidal interaction.

Contributing Editor **SUE FRENCH** welcomes your comments and observing stories. She can be reached at scfrench@nycap.rr.com.

▲ Above: Because NGC 4567 and NGC 4568 are in the early stages of their merger, the structure of their spirals is still obvious. This LRGB image shows what can be captured of the interaction with a 17-inch astrograph (total exposure time = 18 hours). Inset: Dale Holt's video setup also revealed the distended halos of interacting galaxies NGC 4567 and NGC 4568.

oval, NGC 4551 rests atop the lid and covers a petite ¾'. Both galaxies are easily seen in the 10-inch scope at 115×. NGC 4550 presents a large, brighter, elongated interior, while NGC 4551 bears a broadly but only slightly brighter interior. At 187× NGC 4550 stretches across 2'. NGC 4551 is a fat oval tipped east-northeast, bridging 1' and holding an elusive stellar nucleus.

Messier 58 shares the field of view with M89 through the 130-mm refractor at 23×. Compared to its field mate, M58 is larger with lower surface brightness, but it grows more luminous toward the center. An 8th-magnitude star sits 7.6' due west. At 63× its oval form tips east-northeast, and at 117× the oval enfolds a tiny, vivid nucleus and is swathed in a rounder, dim, 3½'

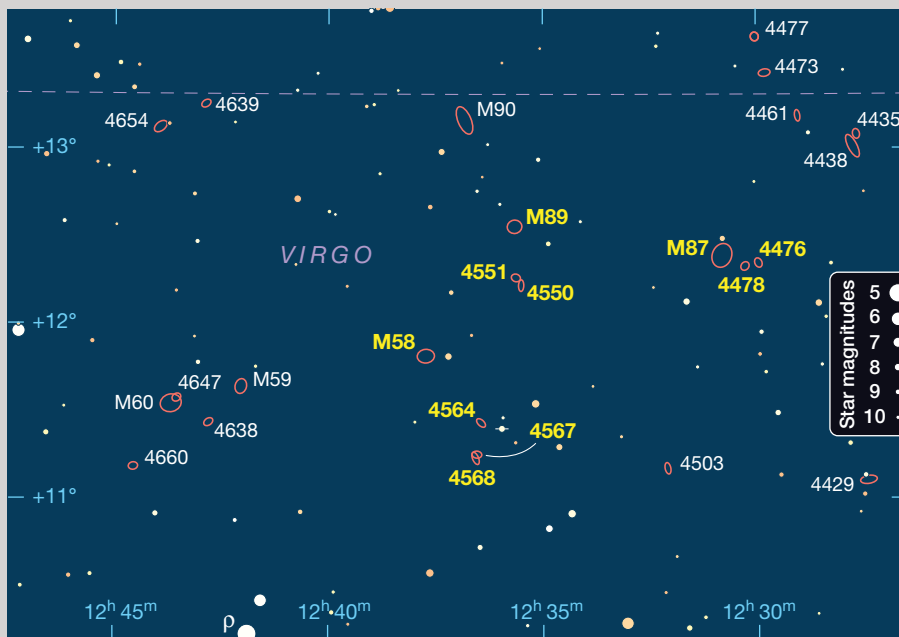

The Coma Cluster

Want to observe a galaxy or two?

Point your scope toward the rich cluster in Coma Berenices.

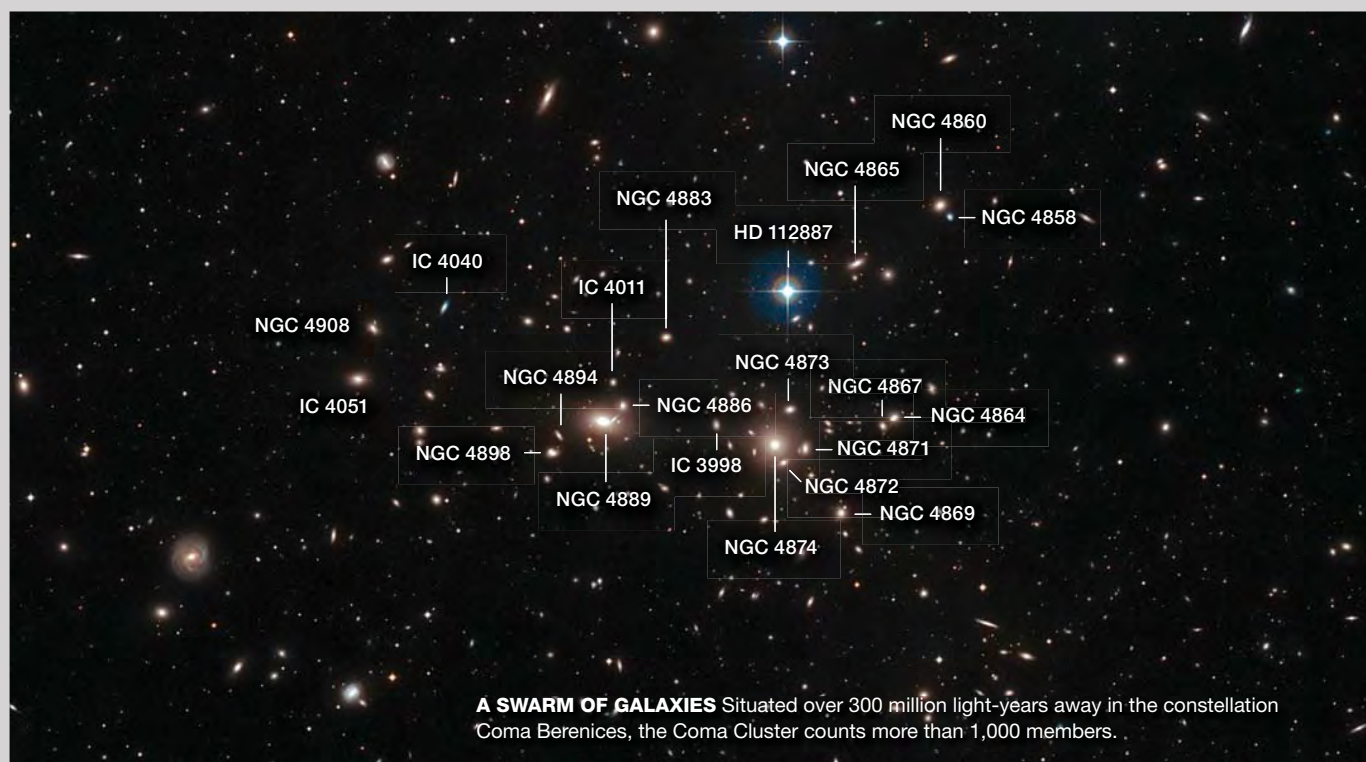

Richer and denser than the Virgo Cluster and containing thousands of galaxies, the **Coma Cluster** (Abell 1656) is a telescopic wonderland that takes its name from its parent constellation, Coma Berenices. More than a hundred visible galaxies are packed into an area only a little greater than 3° in size; as many as 50 are visible in a 16-inch telescope. Exploring beyond its two dominant members is a challenge, though. At almost six times farther than the Virgo Cluster, its members are three or four times fainter. You can enjoy the sample tour I describe here with hardly more than a nudge of your telescope: The objects are contained in a single field of view of less than 1° .

The Coma Cluster lies about 2.5° west of Beta (β) Comae Berenices along an imaginary line connecting Beta and

Gamma (γ) Comae Berenices. The center of the cluster is about $7'$ southeast of a magnitude-7.2 star (HD 112887). Dominating the middle of the cluster are two giant elliptical galaxies just $7'$ apart, both visible in an 8-inch scope. **NGC 4889** is officially the brightest galaxy in the cluster at magnitude 11.5, but neighboring **NGC 4874** has a slightly higher surface brightness and appears more brilliant to the eye. Both have significantly brighter cores surrounded by large, luminous halos, with NGC 4889 being noticeably more elongated. The two galaxies each anchor their own group of smaller, fainter companions and stand out strikingly among the many neighbors that cluster around them.

William Herschel discovered both of these galaxies in April 1785. Herschel

was the first to explore the cluster, but several other famous observers, including John Herschel, Heinrich d'Arrest, and Guillaume Bigourdan, are credited with discoveries here. And they are each responsible for various errors and ambiguities that John Dryer had to sort out when he compiled the *New General Catalogue*. Modern historians continue working to unravel some of the more puzzling discrepancies, so the pedigree of a few objects remains in contention. For instance, NGC 4889 is equivalent to NGC 4884; the dual designation is due to a second observation of the galaxy by d'Arrest that he mistakenly recorded as a new object.

NGC 4886, a smaller elliptical paired with NGC 4889, also has a dual designation (NGC 4882); d'Arrest observed the pair again on a differ-

ent night, and, not recognizing them, assigned them both new designations. NGC 4886 is round with a bright core and lies at approximately the same distance as its larger neighbor, around 300 million light-years.

Averted vision will reveal a pair of similar galaxies about 2' east-southeast of NGC 4889. **NGC 4898** is an elliptical galaxy that appears round, while **NGC 4894** is a lenticular galaxy, a class of galaxies that are intermediate between ellipticals and spirals. NGC 4894 lies about 100 million light-years closer to us than the core of the Coma Cluster. As with most giant galaxy clusters, the center of the Coma Cluster is populated with ellipticals. The spiral galaxies that are associated with the cluster are typically found in the outskirts, and the lenticular galaxies, such as NGC 4894, are generally intermediate both in morphology and distance from the cluster core. A little more than 1.5' to the north of NGC 4889 is tiny **IC 4011**, appearing as a small round spot of uniform brightness. An elliptical, it is at a distance that puts it near the center of the cluster.

Northwest of NGC 4889 at a separation of about 4.5' is **NGC 4883**, a small, round, barred lenticular galaxy that has a brighter core.

The western giant, NGC 4874, is surrounded by its own retinue of smaller galaxies that form an oval ring. Lying less than 1' to the southwest is **NGC 4872**, which has a somewhat muddled discovery history. It was most likely missed by William and Caroline Herschel and possibly first observed by d'Arrest. Errors in position and an ambiguous description by d'Arrest (his notes could apply to any of three close companions to NGC 4874) muddies the waters. Moving counterclockwise, we find **NGC 4871** a little more than 1' to the west of NGC 4874 and **NGC 4873** about 1.5' to the north. Both are similar lenticular galaxies with small bright cores. **IC 3998**, some 2.5' to the east-

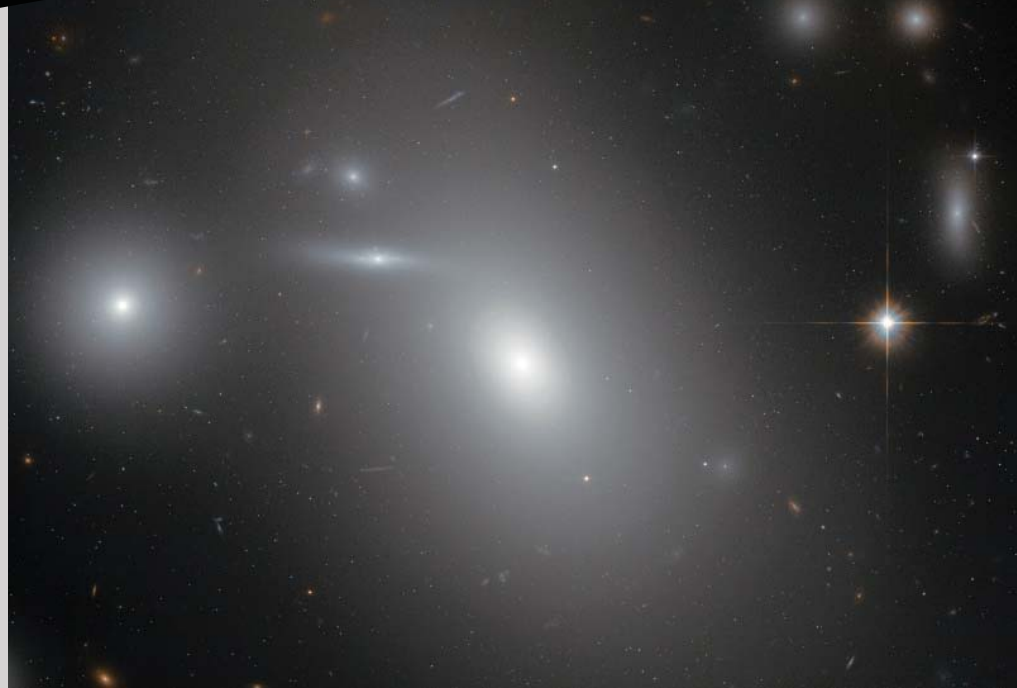

▲ **THE QUEEN IN THE CLUSTER** NGC 4889, an elliptical, is the largest of the galaxies in the Coma Cluster and harbors possibly one of the most massive black holes known to date, weighing in at some 21 billion solar masses.

northeast of NGC 4874, lies behind the core of the cluster at around 460 million light-years. It appears small, faint, and round. A number of small galaxies with PGC designations complete the oval ring of satellite companions, though they will require very large aperture to trace out.

Some 5' west of NGC 4874 lies the close pair comprised of **NGC 4864** and **NGC 4867**. On the night of April 11, 1785, William Herschel described

three nebulae in the core of the Coma Cluster. NGC 4889 and NGC 4874, the two brightest galaxies in the cluster, are certainly two of the three, but the third is somewhat in doubt. Harold G. Corwin speculates that the third nebula might have been the combined glow of NGC 4864 and NGC 4867 along with a superimposed star that lies just southeast of NGC 4864's core. These two galaxies are less than 1' apart.

Corwin notes that the other likely possibility for William Herschel's third nebula might be **NGC 4869**, which lies about 4' southwest of NGC 4874. It is one of the five brightest galaxies in the heart of the cluster and appears round with a bright core.

Some 8' east-northeast of NGC 4889 is one of several concentrations of faint but detectable galaxies that surround the core of the cluster. My 30-inch Dobsonian shows eight galaxies in this quadrant easily enough. The three brightest are **NGC 4908**, a 13.6-magnitude elliptical that has a brighter core, **IC 4051**, a more elongated 13.2-magnitude elliptical, and **IC 4040**, classified as a radio galaxy. Radio galaxies are a

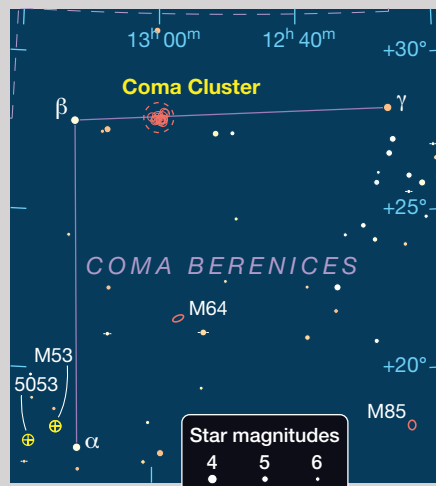

type of active galaxy that is very bright at radio wavelengths due to the interaction of powerful jets with the interstellar medium. We can only imagine the violence of the scene; the visual galaxy is very average-looking and reveals no hint of the activity occurring there.

About 3' to the northwest of the bright field star HD 112887 is **NGC 4865**, a foreground lenticular that has a bright core. Some 4' farther northwest is a close pair. The bright elliptical **NGC 4860** is just 38" from its fainter, smaller companion **NGC 4858**. The two are not proximate in space: NGC 4858 is a barred spiral that lies more than 60 million light-years behind its

larger neighbor. Both galaxies have bright cores.

Our tour but scratches the surface of this cluster. Several dozen more galaxies lie within this single field, and many more galaxies will come into view with a gentle nudge of the scope in nearly any direction.

A compellingly emotive aspect of visual observing is the sense of reliving the experiences of the famous observers of the past. Exploring a distant galaxy cluster by eye, you are, at that moment, the last in a line of observers stretching back centuries to the discoverer of the object. Observing the Coma Cluster, we can feel privileged to be sharing a

unique moment with William Herschel and Heinrich d'Arrest. No matter how many observers stand between them and you, the visceral impact is undiminished, the view unchanged. Contemplate that incredible fact when next you put eye to eyepiece, and it just might offer you a new perspective and add a touch of awe to your observing session.

■ Contributing Editor **TED FORTE** explores the deep sky from his home observatory outside Sierra Vista, Arizona. His regular Backyard Astronomer column runs monthly in the *Sierra Vista Herald/Review*.

Coma Cluster Components

Object	Type	Surface Brightness	Mag(v)	Size	RA	Dec.
NGC 4889	Elliptical	13.3	11.5	2.9' × 1.9'	13 ^h 00.1 ^m	27° 59'
NGC 4874	Elliptical	13.1	11.7	1.9' × 1.9'	12 ^h 59.6 ^m	27° 58'
NGC 4886	Elliptical	12.8	13.9	0.6' × 0.6'	13 ^h 00.1 ^m	27° 59'
NGC 4898	Elliptical	12.0	13.5	0.6' × 0.4'	13 ^h 00.3 ^m	27° 57'
NGC 4894	Lenticular	12.6	15.2	0.5' × 0.2'	13 ^h 00.3 ^m	27° 58'
IC 4011	Elliptical	—	15.0	0.4' × 0.3'	13 ^h 00.1 ^m	28° 00'
NGC 4883	Barred lenticular	12.9	14.4	0.6' × 0.5'	12 ^h 59.9 ^m	28° 02'
NGC 4872	Barred lenticular	12.8	14.4	0.6' × 0.4'	12 ^h 59.6 ^m	27° 57'
NGC 4871	Lenticular	12.6	14.1	0.7' × 0.4'	12 ^h 59.5 ^m	27° 57'
NGC 4873	Lenticular	12.9	14.1	0.7' × 0.5'	12 ^h 59.5 ^m	27° 59'
IC 3998	Barred lenticular	—	14.6	0.6' × 0.4'	12 ^h 59.8 ^m	27° 58'
NGC 4864	Elliptical	12.4	13.6	0.7' × 0.5'	12 ^h 59.2 ^m	27° 59'
NGC 4867	Elliptical	12.8	14.5	0.5' × 0.4'	12 ^h 59.3 ^m	27° 58'
NGC 4869	Elliptical	13.1	13.8	0.8' × 0.7'	12 ^h 59.4 ^m	27° 55'
NGC 4908	Elliptical	12.9	13.6	0.8' × 0.6'	13 ^h 00.9 ^m	28° 02'
IC 4051	Elliptical	13.3	13.2	1.2' × 0.9'	13 ^h 00.9 ^m	28° 00'
IC 4040	Spiral	13.4	14.8	1.0' × 0.3'	13 ^h 00.6 ^m	28° 03'
NGC 4865	Elliptical	12.8	13.7	0.9' × 0.5'	12 ^h 59.3 ^m	28° 05'
NGC 4860	Elliptical	13.3	13.5	1.0' × 0.8'	12 ^h 59.1 ^m	28° 07'
NGC 4858	Barred spiral	13.3	15.2	0.5' × 0.4'	12 ^h 59.0 ^m	28° 07'

Angular sizes and separations are from recent catalogs. Visually, an object's size is often smaller than the cataloged value and varies according to the aperture and magnification of the viewing instrument. Right ascension and declination are for equinox 2000.0.



SOUTHERN PEACE A thin crescent Moon pairs with a lustrous Venus in this 2.5-second exposure taken from Arkaroola Wilderness Sanctuary.

JURIJ STARE



A Journey to the **Dark Site** of the Earth

A summer trip **Down Under** offered these observers their best views of some dramatic, deep-sky sights.

Australia is one of the first places we think of when southern skies are mentioned. It's on a short list of countries that still have substantial areas where natural dark skies are preserved. In Europe and the United States, such dark locations can be almost impossible to find; for true darkness, there can't be any settlements or other sources of light pollution within a 300-km (190-mile) radius. There is, however, one more element that makes Australia a unique place for amateur astronomers. It's the presence of a huge, hot interior which, after 100–200 km of travel inland, leads us to places with very good weather statistics and laminar flow of air. Consequently, the traveler is located not only in a dark place surrounded by southern skies, but also the seeing is amazingly good.

Arkaroola Wilderness Sanctuary

During the (Northern Hemisphere's) spring of 2016, we decided to spend our next vacation "Down Under," in one of those amazing places in the Australian Outback. We chose the Arkaroola Wilderness Sanctuary, which has a small settlement that had enchanted the second author of this

article during a short visit back in 2011. Arkaroola Wilderness Sanctuary (arkaroola.com.au) lies in the northern part of Ikara-Flinders Ranges National Park, about 700 km north of Adelaide, the capital of South Australia. To get there, a four-wheel-drive vehicle is recommended, because the last 150 km of the 700-km road from Adelaide is unsealed (i.e., dirt). A nearby airfield makes it possible to get there by small aircraft as well. The sanctuary's remote location can cause problems not only with transportation, but also with regard to electricity, which is locally produced by a small generator. This relative scarcity, however, does have a good side effect: Limited access to power creates a truly dark observing site.

Arkaroola is a mecca for bushwalkers, four-wheel-drive enthusiasts, and nature and wildlife lovers. In fact, Arkaroola is a resort and a tourist shelter for active trans-Australian travelers who stay there for a few days before continuing their journeys across the continent. And, since the owner Doug Sprigg is an avid amateur astronomer, the sanctuary also sports three fully equipped observatories for visitors. Two dome observatories each house a motorized 14-inch Schmidt-Cassegrain telescope, and a roll-off-roof observatory boasts a 16-inch Go To Dobsonian, a 12-inch Dobsonian, a Meade ETX-125, and two motorized chairs equipped with 20×100 binoculars.

The first author of this article is foremost an astrophotographer, so he took along a lot of photographic equipment: an HEQ-5 mount, two DSLR cameras, a bunch of lenses, and an 80-mm apochromatic (APO) telescope. One can imagine that there wasn't much space left in the luggage for the usual things taken on a 3-week trip! Luckily, we didn't need to bring a counterweight on the plane as we were able to use one from the Arkaroola inventory. The second author brought quality 2-inch eyepieces: a 31-mm Nagler and a 17-mm Ethos to be used with the 16-inch Dobs of Arkaroola. He also packed two DSLR cameras for wide-field, tracked photographs and ultra-wide time lapses.

Since Australia is in the Southern Hemisphere, July is a winter month with very long nights. Astronomical night begins around 7 o'clock in the evening and ends around 6 o'clock in the morning. This timeframe coincides with good visibility of the Milky Way in both hemispheres. In South Australia, winter also means better temperatures. While we were there in July and August the temperature reached a comfortable 20°C (68°F) during the day, while at the end of the night only very rarely did it plummet down to a bit under 0°C (32°F). We spent a total of 17 days in Arkaroola, and out of those we managed to observe on 13 nights. It's true that it rained one night, but in the morning there was no evidence of any precipitation.

It's Really Dark Here

The view of the winter Milky Way from -30° latitude is truly impressive. The center of the galaxy lies right on the zenith. The stories that say the Milky Way can cast a shadow are not exaggerated — raising a hand above the ground easily proved

▼ **MAP** Hop in your all-terrain rig and hit the road for Arkaroola Wilderness Sanctuary. Head north from Adelaide until you run out of pavement, then enjoy two more hours of driving on "unsealed" roads.

▼▼ **DESERT VISTA** The Arkaroola Wilderness Sanctuary nestles in the hills of the Flinders Ranges about 700 km north of Adelaide.

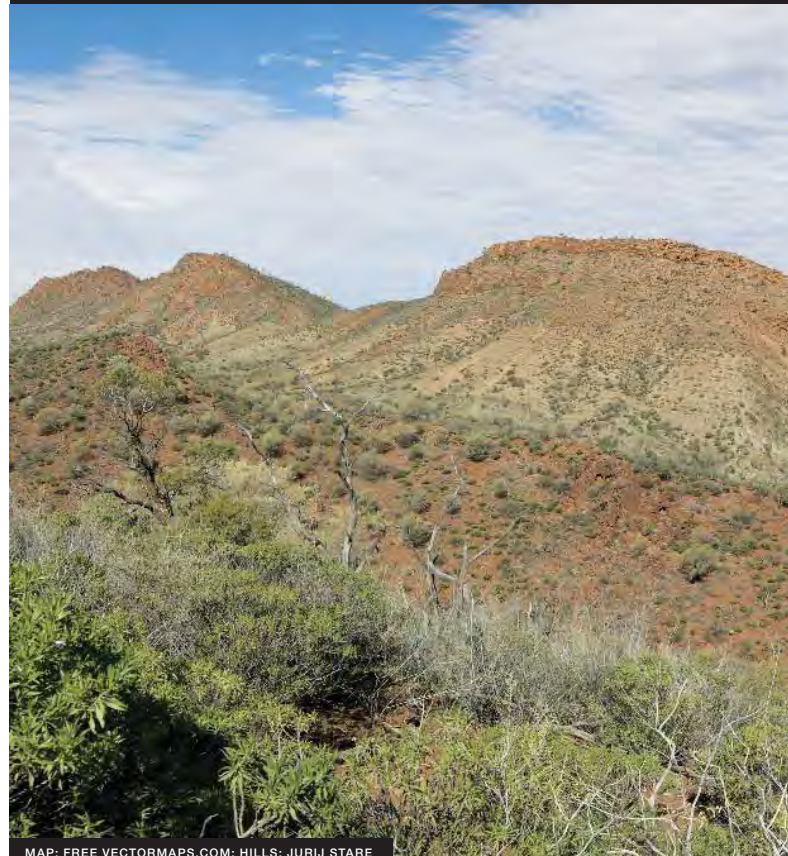

MAP: FREE VECTORMAPS.COM; HILLS: JURIJ STARE

Arkaroola is a mecca for bushwalkers, four-wheel drive enthusiasts, and nature and wildlife lovers.

this. In Arkaroola, there's absolutely no sign of any light pollution that would show on "all-sky" (180° fisheye-lens) images. The sky transparency was also excellent, with stars visible all the way to the horizon. A Sky Quality Meter (SQM) confirmed the extreme darkness of the night sky, showing a brightness of 21.92 magnitudes/square arcsecond when the Milky Way was setting. (For comparison, Howard Banich measured a SQM of 21.76 with the wide-angle meter at the 2017 Oregon Star Party.) When the Milky Way was at the zenith, we measured a SQM of 21.55, which appeared to be the natural difference caused by the brightness of our galaxy's center at the zenith.

Looking up with unaided eyes gave us a clear impression that we were observing a spiral galaxy "edge on," from the inside. At the beginning of the night, we were always greeted by strong zodiacal light in the west, which gradually faded as the night progressed before reappearing in the east as dawn approached. It was interesting to note that just a two-day journey by car could take us to the latitude of Melbourne, where auroras can sometimes be spotted.

Though Arkaroola is very arid, dew started to form on the optics by the end of the night. This could have been a troublesome factor, particularly for the long, wide-field time lapses we planned. Fortunately, we came prepared with dew heaters, which were turned on for longer photographic sessions. Apart from this, e.g., for visual observations or exposures of just a few minutes, dew wasn't a problem.



**Looking up
with unaided
eyes gave
us a clear
impression
that we were
observing a
spiral galaxy
“edge on.”**



▲ **ALL-SKY SPLENDOR** From a vantage point in the Southern Hemisphere, with no light pollution to interfere, the Milky Way comes into its own, as proven in this 180° view of the sky above Arkaroola captured through a fish-eye lens.

▼ **CLOUD CONGREGATION** The globular cluster NGC 6723 (upper right of center) lies some 30,000 light-years past the dramatic nebula complex of NGC 6726, NGC 6727, NGC 6729, and IC 4812 in Corona Australis.





STELLAR FLAMBOYANCE Although visible from northern climes, it takes a trip to the Southern Hemisphere to truly appreciate the resplendent Rho Ophiuchi cloud complex. The first author captured the colors of this star-forming region in twenty-four 2-minute exposures and twelve 5-minute exposures using a DSLR camera with a 200-mm lens at f/4.



The telescopic view of Omega Centauri, which is almost as big as the full Moon, overwhelmed us.

A Few North, A Few South

We carried out more serious astrophotography with the 80-mm APO, focusing on astronomical objects that are impossible, or very difficult, to photograph from northern latitudes. Prior to the trip, we compiled a “top 20” list of objects to image so we’d have a plan to follow. Even though Europe and the contiguous United States share large portions of the sky with the Southern Hemisphere, objects that are typically near zenith (when viewed from the south) are significantly easier to image than when they are just 10° or 20° above the horizon (when viewed from the north). That’s why we added quite a few targets that are also visible from northern latitudes to our “top 20” list.

One of those objects was the Rho Ophiuchi cloud complex, which can’t be successfully photographed from far northern latitudes. From Arkaroola, it was a piece of cake, requiring only two hours of exposure. The same was true with Omega Centauri, which we easily saw from the Canary Islands a few

years earlier. From Arkaroola, it was even higher and thus brighter. A very easy target!

We had a wonderful opportunity to compare two of the brightest globular clusters in the sky to M13 in Hercules, which, as seen from Europe, is considered “bright.” This was a no-contest comparison, to say the least. Even on paper Omega Centauri and 47 Tucanae are by far brighter and larger, but when you see the difference with your own eyes, it’s obvious they dwarf M13. In particular, the telescopic view of Omega Centauri, which is almost as big as the full Moon, overwhelmed us and left a long-lasting impression.

We spent time with a few other southern objects including Centaurus A (a galaxy known for its particular radio activity), the Jewel Box cluster (NGC 4755), and the Eta Carinae Nebula with its yellowish star within. An obvious southern target was the Large Magellanic Cloud. Its internal structure is so delicate and complicated that browsing it with the 16-inch and a wide-field eyepiece was a source of great pleasure.

In summary, our top three visual southern objects were Omega Centauri, Centaurus A, and 47 Tuc. It's no surprise that two of them are globular clusters. Indeed, these massive aggregates of stars, when viewed with large telescopes from a truly dark location, gained a lot and become more comparable to long-exposure photographs. Centaurus A, on the other hand, looked exactly like it does in popular photographs — a rare situation for galaxies viewed through the telescope.

In addition to the typical southern targets, we could see all the deep-sky objects of Sagittarius and Scorpius close to the zenith during July and August from Arkaroola. These usually require binoculars in Europe, but they suddenly became naked-eye targets! At the end of the night, our familiar winter constellation, Orion, and its bright M42 nebula could be seen at an altitude not possible from Europe or the continental United States. This, combined with the extremely good weather conditions in Arkaroola, made it possible for us to view the nebula directly in living color!

One night we tried for one of the difficult objects of the Northern Hemisphere, the famous Helix Nebula (NGC

7293). We located the object with the 16-inch and 31-mm eyepiece. We were, however, a bit confused, because at about 50× magnification and a very wide field of 1.6°, the object appeared too big for the planetary nebula, and the expected “donut” shape didn't seem to have a hollow. We exchanged the eyepiece for the Ethos 17-mm (88×), and we're happy to report that the Helix returned to its normal donut shape.

◀ **WORTH THE TRIP** The Eta Carinae Nebula tops the list of “most desired targets” for almost every amateur astronomer, but at a declination of -60° , it requires northern observers to hit the road to see it. This stunning view was captured with forty 5-minute exposures with a DSLR mounted on an 80-mm apochromatic refractor.

▶ **DOUBLE THE FUN** The Magellanic Clouds, Large and Small, are members of the Local Group and orbit our own Milky Way Galaxy. Separated by 21° on the sky, the duo is visible to the naked eye. A telescope reveals not just more of the galaxies' structure, but a wealth of deep-sky objects to explore as well.

Later the same night we tried for another stunning object hardly visible from latitude 50° north, where it lies about 7° degrees above the horizon. This was the famous Great Sculptor Galaxy (NGC 253), also known as Silver Coin Galaxy. From Arkaroola, it was almost at the zenith. What an amazing, detailed view we had using the 16-inch Dob with the 17-mm Ethos. The same could be said for our view of the nearby, smaller Milkweed Seed Galaxy (NGC 247).

We wondered: Which splendid northern deep-sky objects cannot be seen from here? It appears that only three such objects could be named without doubt: the two compan-

ion galaxies of the Big Bear, M81 and M82, and the Great Andromeda Galaxy (M31). The latter can be seen from Arkaroola, but it's very low on the horizon, while it's a magnificent binocular object when close to the zenith from northern latitudes (August–October). So, the southern skies seem to have more, and more interesting, objects to offer stargazers. The other clear advantage of the southern skies is that the entire shape of the Milky Way is better seen during the long nights of the Australian winter.

Of course, we didn't leave out Saturn, which was ruling the zenith with Scorpius in July–August 2016. Through the 16-inch Dob, the ringed planet was steadier and sharper than we had ever seen it before. The Cassini division was apparent all the way around, and one could clearly see seven bands on the planet's “surface” in color. A simple Dobsonian was enough — no need to use the expensive 15-cm APO.

After 17 days of pure astronomical pampering at Arkaroola, we returned to Adelaide, where boarded our plane to fly back to Europe via Doha. We were very pleased with our astro-vacations in the Southern Hemisphere and promised



ourselves we'd return one day to experience the Australian wilderness together with truly dark skies.

■ **JURIJ STARE** is an experienced astrophotographer who runs a software firm dealing with GIS in Slovenia. He's also an activist for the International Dark-Sky Association. **ZBIGNIEW ZEMBATY** is a professor at Opole University of Technology in Poland, where he conducts research in civil engineering and geophysics. A life-long amateur astronomer, he uses a 20-inch Dobsonian for visual observations. Whenever possible, he travels to stargaze from remote locations with truly dark skies.

FURTHER READING: For more astro images taken from Arkaroola by Jurij Stare, see <https://is.gd/AustraliaObserving>.

Hunter's Zoom Finder

This innovative design solves several problems at once.

HUNTER DAVIDSON LIVES NEAR a large city, which subjects him to heavy light pollution. He also enjoys manually aiming his telescope, a practice that offers limited success when the magnitude-4 sky reveals maybe a dozen stars. For the last several years he has experimented with different types of finders, but he found little that worked well for him.

He reports, "Telrads and other reflex finders provide wide fields of view, but in my poor skies it's often difficult to see enough stars, and looking through any glass further limits visibility. A split-pupil finder (*S&T*: June 2013, p. 66) eliminates the intrusion of any glass and is very wide angle, but my old bones don't like crouching to look straight through finders. Adding a large mirror to my split-pupil finder solved that problem, giving me a 50° field or more and, interestingly, the sense of slightly better star visibility, but even so I just couldn't see enough stars on many nights."

Hunter needed an optical finder that

▼ *Left:* The finder's zoom lever is easy to reach and operate in the dark. *Right:* Components of the zoom finder are relatively easy to assemble, and simple to use.

would offer some gain. The trouble is, that would lead to a narrower field of view, which would reduce the number of useful field stars and put him right back where he started. He began asking himself, "So what provides both wide-angle at about naked-eye field of view as well as some magnification when needed?" The answer: a zoom finder.

Hunter's other hobby is building stuff. With the words "zoom finder" rattling around in his head, he went into his shop and mated a Sony 20-80 mm f/2.5 TV zoom lens to an inexpensive Amici roof prism and the lenses from a 20-mm Plössl eyepiece. He couldn't use the entire eyepiece because the focal point of the zoom lens lies inside the prism, so he had to mount the eyepiece lenses so their focal point reached the same plane.

The result is a finder that zooms outward to give him a 50° field of view, which allows easy orientation even with only a few reference stars. Zooming to the narrowest field of view, 12.5°, adds about 3 magnitudes of gain, bringing out more stars as the field narrows. Designed for television cameras, the lens has a smooth-acting lever for zooming, so Hunter can shift back and

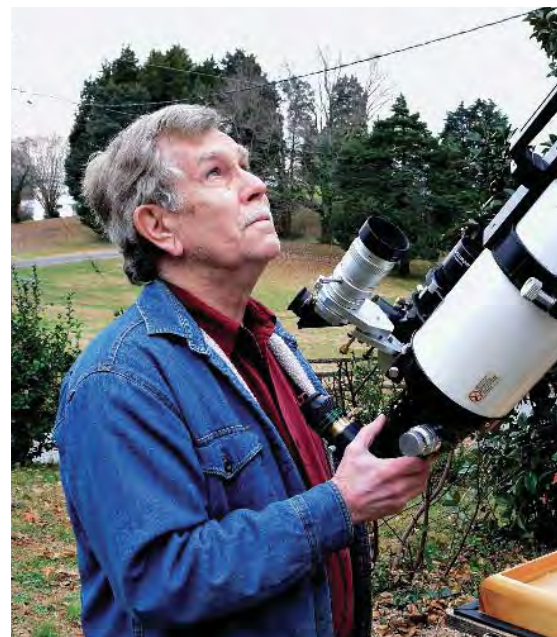

forth easily without jiggling the scope.

At its widest, the finder's field of view includes the front of the telescope, making it difficult to judge where the center is. Even at full zoom, its 12.5° field is still a lot wider than the 1° field of a typical low-power eyepiece, and Hunter soon realized the biggest hiccup in his design: With the focal plane inside the Amici prism, he couldn't add cross-hairs to indicate the center of his finder's field. So he augmented his zoom finder with a second, conventional 5° optical finder. Together the two finders let him zero in on just about any target visible in his sky.

Then one night while zooming in on a target, Hunter had an epiphany: The zoom could function like cross-hairs. An object that's not centered will drift

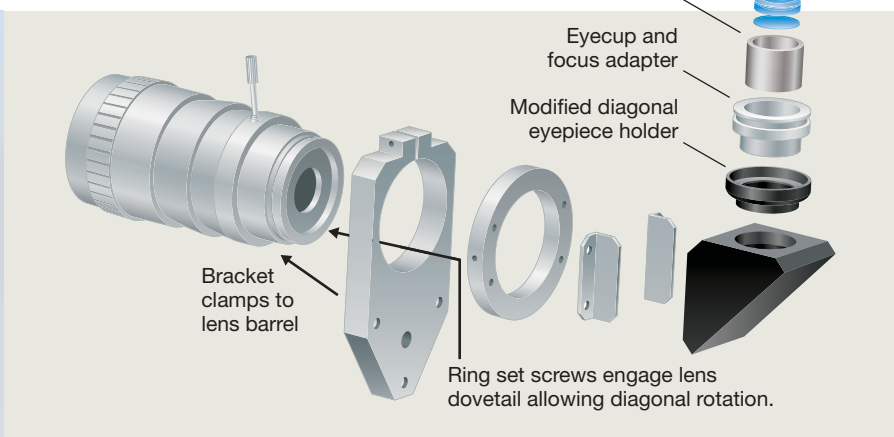

HUNTER DAVIDSON (2); EXPLODED DIAGRAM: GREGG DINDERMAN / S&T



▲ Hunter Davidson uses his zoom finder to locate guide stars in his light-polluted sky.

to the side when zoomed, but an object in the center of the field will stay put. Hunter reports, "The long hand lever of the lens makes adjustment very easy, so I just zoom in and out, tweaking the scope position until the target star doesn't move. This is quicker than one might imagine and became second nature."

Now he says the most serious downside is that "this optics combination provides, to be kind, not the sharpest star images. But I find the images good enough, and 'good enough' seems okay for this application."

These zoom lenses are available on eBay fairly frequently and can be found with a little patience. Other zoom lenses might work as well, but make sure they come to focus far enough away from the rear element to allow room for a prism and eyepiece.

The zoom finder nicely solves the problem of star-hopping in light-polluted skies, and it would probably be equally useful in dark sky as well. Hunter's final assessment is this: "Like my scopes, the finder I use most is the best one I have . . . and I use this one all the time."

For more information, contact Hunter at hunterdavidsonjr@gmail.com.

■ Contributing Editor JERRY OLTION festoons his telescopes with finders of all description. A zoom may soon join the others.

KITT PEAK NATIONAL OBSERVATORY

Tucson, Arizona

Year-Round Programs:

- Nightly Observing Program
- Dark Sky Discovery Program
- Daytime Guided Tours
- Public Programs for Amateur Astronomers
- Periodic Astrophotography Workshops
- Image Queue Data Gathering
- VIP Tours

START YOUR JOURNEY BY VISITING
www.nao.edu/kpvc
 Located on the Tohono O'odham Reservation

Mars Globes from Sky & Telescope

Mars Globe
 Created from more than 6,000 images taken by the Viking orbiters and produced in cooperation with NASA and the U.S. Geological Survey, this globe includes official names for 140 features and the landing sites for Spirit, Opportunity, Phoenix, and Curiosity.

Item #4676X \$99.95 plus shipping

Topographic Mars Globe
 Derived from millions of laser-altimeter measurements by NASA's Mars Global Surveyor orbiter, this data set has revolutionized our understanding of Martian geology.

Item #TPMARGL \$109.95 plus shipping

SHOP SKY 888-253-0230 shopatsky.com

How Do YOU Tak?

M31 & M32
 FSQ-85EDX W/FLT
 KEN SHINJUKU, JAPAN

MILKY WAY MOSAIC
 FSQ-106EDX4
 MATT DIETERICH, USA

Tag us on Instagram
 @takahashiamerica
 to be featured!

TAKAHASHI AMERICA

takahashiamerica.com

NEW PRODUCT SHOWCASE

CENTERBALANCE MOUNT ▶

iOptron now offers the CEM120 (\$3,999), a heavy-duty equatorial head that positions the weight of the scope over its true center of gravity compared to typical equatorial mounts. The CEM120 weighs 57 lb (26 kg) and boasts a 115-lb (52 kg) load capacity. Its 216-mm, 360-tooth gears on both axes provide a low periodic error of 3.5 arcseconds. Its spring-loaded saddle plate accepts Losmandy “D” style dovetail bars. The CEM120 can be operated at any latitude and comes with iOptron’s Go2Nova 8407 Go To controller. The mount’s built-in WiFi and LAN permits remote operation, and the unit incorporates several electrical pass-through ports, including both USB 2.0 and 3.0, to reduce cable snags. Two 22-lb (10 kg) counterweights are included with purchase. A version of the mount with high-resolution encoders is available for \$5,500.

iOptron

6F Gill St., Woburn, MA 01801
866-399-4587; ioptron.com

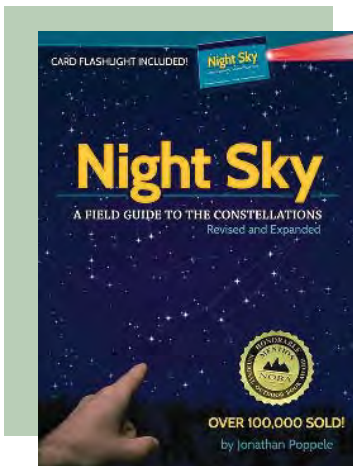

◀ CONSTELLATION BOOK

The award-winning book *Night Sky: A Field Guide to the Constellations* by naturalist Jonathan Poppele is now in its second edition. The book has been completely revamped and expanded, including a new introduction. Poppele describes the history and mythology of all 88 constellations and provides star charts depicting the asterisms of each. The book features updated location tables plotting the positions of the planets through 2030, as well as a map showing light-pollution levels across the country and a chart showing how each level of light pollution affects what you can see in the sky. Paperback, 320 pages, ISBN 978-1591932291.

AdventureKEEN

adventurewithkeen.com

COOLED CMOS ▶

QHCCD announces another addition to its COLDMOS camera series, the QHY367C (\$4,399), a 14-bit, full-frame CMOS camera for deep-sky astrophotography. The camera is designed around the Sony color CMOS IMX094 sensor with a 7,376×4,938-pixel array measuring 24×36 mm with 4.88-micron-square pixels. Its dual-stage thermoelectric cooling is capable of stable temperatures of 35° below ambient, producing low-noise images through its USB 3.0 interface with additional proprietary QHY amplifier glow suppression. The unit is capable of recording 3.2 full-resolution frames per second, and even faster rates when using on-chip region-of-interest. An internal 128-megabyte DDRII image buffer ensures no frames are dropped during downloads. Each camera comes with a 1-meter, 12V threaded power cord, a 1.5-m USB 3.0 cable, and a 2-inch nosepiece, plus a CD with camera drivers and control software. See the manufacturer’s website for additional details.

QHCCD

qhccd.com



New Product Showcase is a reader service featuring innovative equipment and software of interest to amateur astronomers. The descriptions are based largely on information supplied by the manufacturers or distributors. Sky & Telescope assumes no responsibility for the accuracy of vendors' statements. For further information contact the manufacturer or distributor. Announcements should be sent to nps@skyandtelescope.com. Not all announcements can be listed.



Jupiter image courtesy Christopher Go using a QHY5-III-290M camera

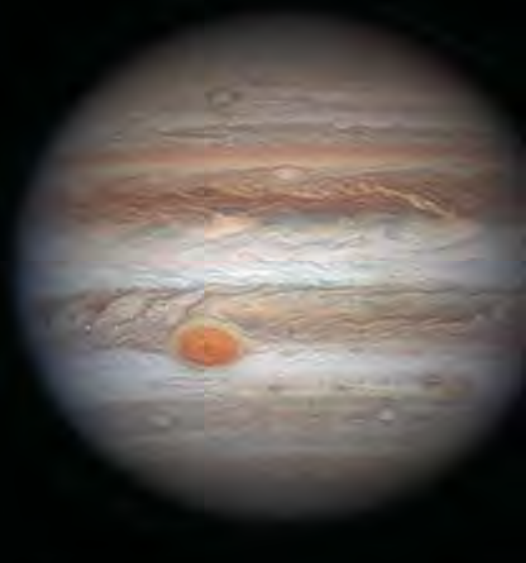

"The QHY5-III-290M camera is so low in noise and so much more sensitive that I could reduce my capture time. I can finish my session in 15 minutes with superior images vs 45 minutes before!" — Chris Go.

Powerful Reliable Affordable

QHYCCD makes over 50 models of CCD and CMOS cameras for amateurs and professionals starting at \$99. Find a Premier U.S. Dealer of QHY products at <http://www.qhyccd.com/USA>

NEAF
NORTHEAST
ASTRONOMY
FORUM™

27TH ANNUAL NORTHEAST ASTRONOMY FORUM & SPACE EXPO APRIL 21-22, 2018

**WORLD'S LARGEST ASTRONOMY, TELESCOPE & SPACE EXPO!
OVER 120 VENDORS, PRO/AM & ASTRONOMY WORKSHOPS,
SOLAR OBSERVING & WORLD-CLASS SPEAKERS FEATURING:**

- JOHN MATHER** NOBEL LAUREATE & PROJECT SCIENTIST FOR THE JAMES WEBB SPACE TELESCOPE
- MIKE LEINBACH** SPACE SHUTTLE LAUNCH DIRECTOR
- TOM MULDER** BOEING CST STARLINER, NAVIGATION, CONTROL, AND MISSION DESIGNER
- PLUS** MANY OTHERS!

SHOW HOURS: SAT 8:30-6 PM, SUN 10-5 PM
SUNY ROCKLAND COMMUNITY COLLEGE
SUFFERN, NY (ONLY 30 MINS FROM NEW YORK CITY)
BUY TICKETS, GET INFO, HOTEL ROOMS AT:
ROCKLANDASTRONOMY.COM/NEAF



NEAIC
NORTHEAST
ASTRO
IMAGING
CONFERENCE™

**DON'T MISS THE NORTHEAST
ASTRO IMAGING CONFERENCE**
APRIL 19-20, 2018 AT NEAF

**FEATURING IMAGING
WORKSHOPS, LECTURES
& VENDOR EXHIBITS**

Paddy Gilliland
David Lindemann
Bob Stephens

Rachel Freed
Warren Keller
Gary Walker

Dennis Conti
Richard Crisp
John O'Neal

Randy Shivak
Ron Brecher
and many more!

Take Your Pick of Exciting

African Stargazing Safari

August 6–12, 2018

*At press time,
only 4 spaces left!*

Join astronomer and former *S&T* editor Steve O'Meara for this combo safari/star-gazing tour in Botswana. Observe lions, elephants, and other wildlife by day – and the Magellanic Clouds, Eta Carinae Nebula, and more by night. Stay in luxurious field camps. Optional extension to Victoria Falls.



skyandtelescope.com/botswana2018

Join Finnish-American *S&T* editor Diana Hannikainen on this cushy tour from Helsinki to Lapland in search of the gorgeous aurora. Enjoy Finnish and Sami culture and cuisine, stargaze with a local astronomer, stay in glass igloos, take a reindeer safari and Finnish sauna, and more.

The Northern Lights of Finland

March 26–April 2, 2019



skyandtelescope.com/finland2019

New *Sky & Telescope* Tours!

American West Observatories

October 3–16, 2018



GRIFFITH OBSERVATORY, S.N. JOHNSON-ROEHR
METEOR CRATER, NASA EARTH OBSERVATORY

Tour top observatories – Lowell, Palomar, Griffith – and NASA’s JPL. Observe through Mt. Wilson’s magnificent 60-inch scope and the Great Refractor at Lick. Visit the Grand Canyon, Barringer Crater, Las Vegas, and San Francisco. Travel by comfy coach and stay at exclusive hotels.



skyandtelescope.com/observatories2018

Chile 2019 Total Solar Eclipse

June 29–July 5, 2019

Experience the next solar eclipse – July 2, 2019 – from the manicured grounds of the only 5-star facility in the path of totality. Superb viewing and weather prospects. Tour includes visits to two leading observatories and nighttime telescopic observing. Optional extension to Atacama Desert.



skyandtelescope.com/chile2019

2017 ECLIPSE: SEAN WALKER, S&T

Keep up with the latest S&T tour details—bookmark skyandtelescope.com/astronomy-travel

GALLERY

▽ MILKY WAY: SUMMER & WINTER

Tunç Tezel

A small, forest-rimmed reservoir near the village of Bozcaarmut in northwestern Turkey provides the foreground for twin views taken on the nights of August 12–13 (top panel) and November 19–20, 2015.

DETAILS: Modified Canon EOS 6D DSLR camera set to ISO 3200 with a 24-mm lens. Total exposures: 6 minutes and 10½ minutes, respectively.



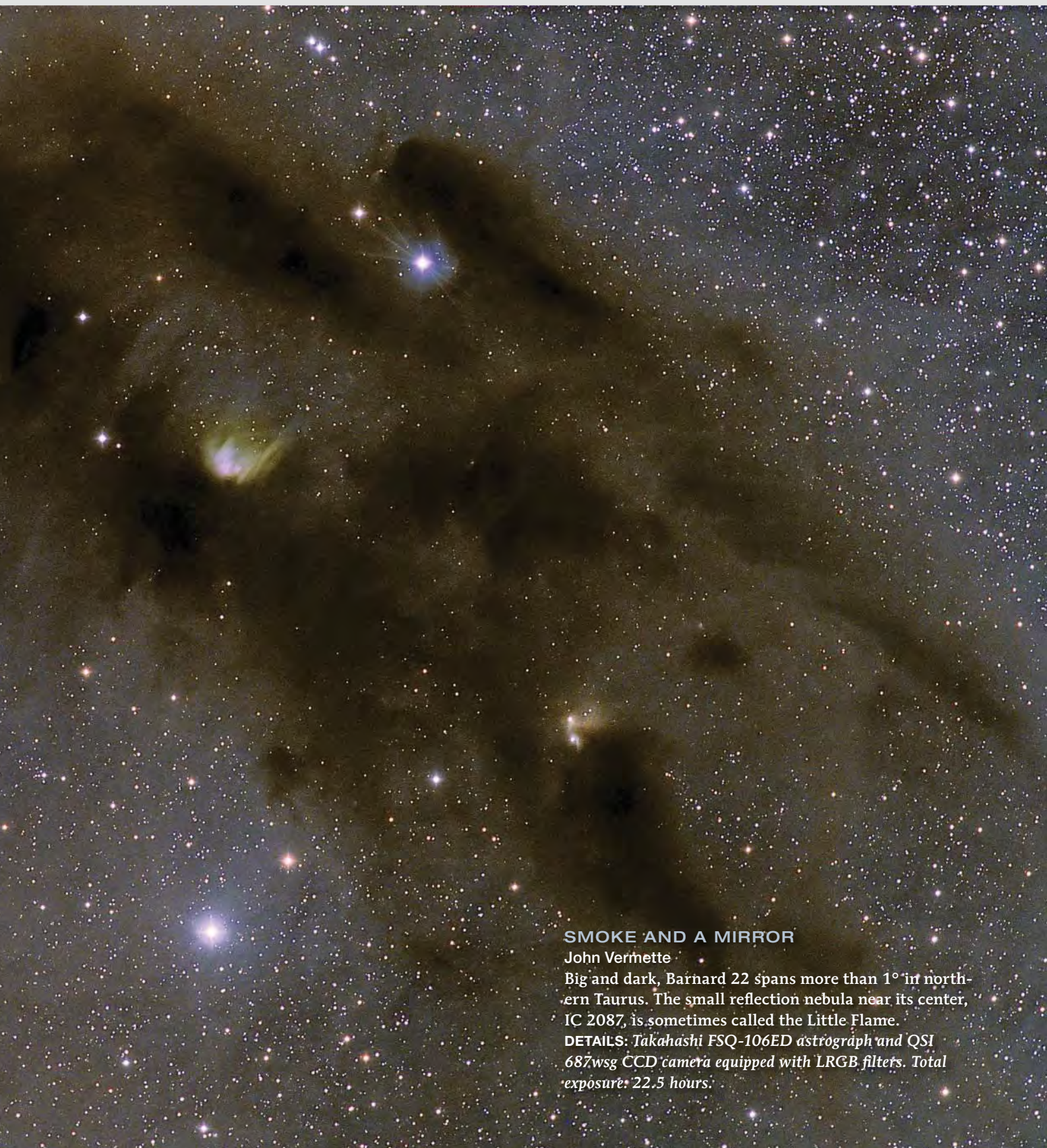

SMOKE AND A MIRROR

John Vermette

Big and dark, Barnard 22 spans more than 1° in northern Taurus. The small reflection nebula near its center, IC 2087, is sometimes called the Little Flame.

DETAILS: Takahashi FSQ-106ED astrograph and QSI 687wsg CCD camera equipped with LRGB filters. Total exposure: 22.5 hours.

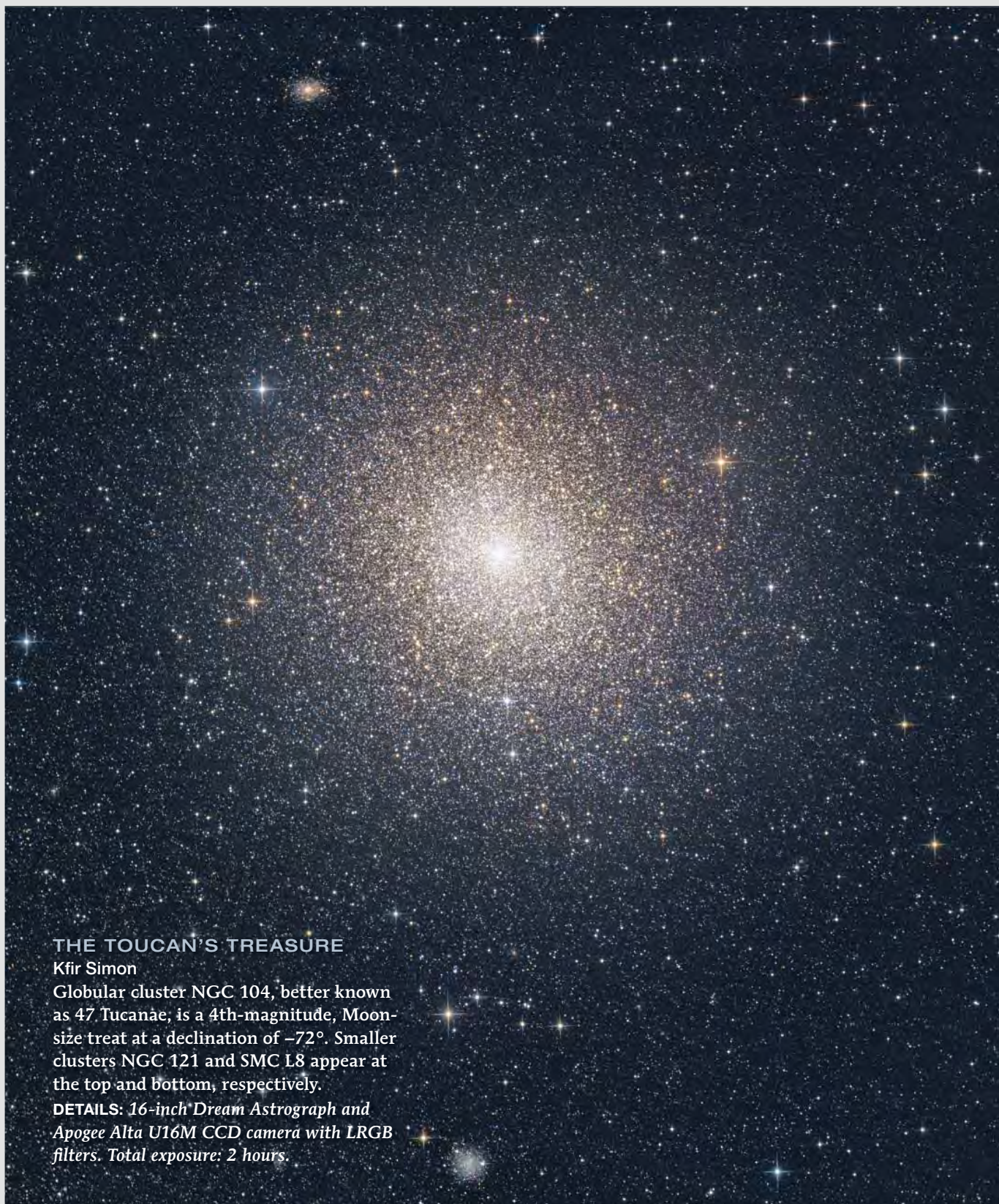

THE TOUCAN'S TREASURE

Kfir Simon

Globular cluster NGC 104, better known as 47 Tucanae, is a 4th-magnitude, Moon-size treat at a declination of -72° . Smaller clusters NGC 121 and SMC L8 appear at the top and bottom, respectively.

DETAILS: 16-inch Dream Astrograph and Apogee Alta U16M CCD camera with LRGB filters. Total exposure: 2 hours.

Gallery showcases the finest astronomical images submitted to us by our readers. Send your best shots to gallery@skyandtelescope.com. See skyandtelescope.com/aboutsky/guidelines.

Visit skyandtelescope.com/gallery for more of our readers' astrophotos.

Steel Yourself

At \$59, this blade of legendary Damascus steel is a real steal

Damascus steel is the stuff of legend. Using a technique first mastered in the ancient city, swords made from Damascus steel were known to slice gun barrels in half and separate single strands of hair in two, even if the hair simply floated down onto the blade.

Now, you can be a part of the legend. The 7 1/2" *August Knife* features a blade of modern Damascus steel, inspired by the production techniques and legends of history. Damascus steel blade knives can cost thousands. So, at \$59, the price itself is also legendary.

Once a lost art, we sought out a knifemaker who has resurrected the craftsmanship of Damascus steel to create the *August Knife*. The elusive, ancient production technique mixes different steel alloys to form a super steel—the outcome is a beautiful one-of-a-kind pattern of banding and mottling reminiscent of flowing water.



BONUS! Call today and you'll also receive this genuine leather sheath!

With the *August Knife* you're getting the best blade money can buy. What you won't get is the inflated price tag. We know a thing or two about the hunt—like how to seek out and capture an outstanding, collector's-quality knife that won't cut into your bank account.

Limited availability. Only a handful of artisans make these blades, with each handcrafted knife taking months to perfect. We currently can get less than 1500 this year, so we can't promise they'll stick around for long—especially at this price. Call today!

Your satisfaction is 100% guaranteed. If you don't feel like we cut you a fair deal, send it back within 30 days for a complete refund of the item price. But we believe once you wrap your fingers around the *August's* handle and experience the beauty of its Damascus steel blade, you'll be ready to carve out your own legend.

August Knife non offer code price \$149*

Offer Code Price Only \$59 + S&P Save \$90

1-800-333-2045

Your Insider Offer Code: AGK227-01

You must use the insider offer code to get our special price.

Stauer® 14101 Southcross Drive W., Dept. AGK227-01
Burnsville, Minnesota 55337 www.stauer.com

*Discount is only for customers who use the offer code versus the listed original Stauer.com price.



**Limited
Collector's
Edition**

**What customers are saying
about Stauer knives...**



*"Very hefty, well-built knife
and sheath. Extremely good-
looking and utilitarian."*

— R., Lacey, Washington



Not shown
actual size.



Rating of A+

- 7 1/2" overall length • Genuine Damascus steel blade • Stainless steel guard • Leather handle • Includes genuine leather sheath

Stauer...Afford the Extraordinary.™

Market Place

Your essential source for astronomical products

ACCESSORIES

Robo-Focus™ Digital Focusing

- * Precision focus control via PC
- * Autofocus capability
- * Full manual operation as needed
- * Temperature compensated
- * Automatic backlash correction
- * Remote power outlet box (option)
- * Fits most scopes & focusers

\$495

See www.homedome.com for details

TECHNICAL INNOVATIONS
407-601-1975 domepage@erols.com
"RoboFocus is a gem!"

Your phone beeps... the sky has cleared!

use it to remotely control your observatory!



HOT PRODUCT 2018 SKY

[AAG Cloudwatcher & Dragonfly](#) observatory automation.

More info: www.lunaticastro.com

BOOKS

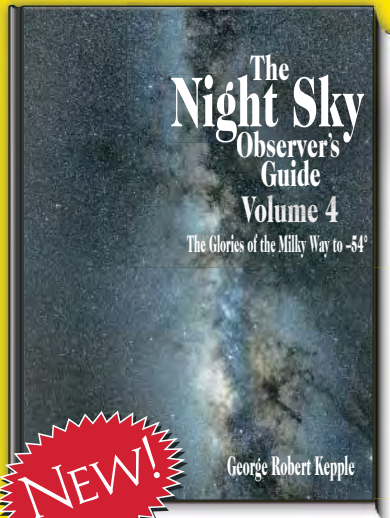

NEW!

Explore the Milky Way as never before!

- 1,809 Objects with descriptions
 - 638 Photographs
 - 268 Sketches
 - 30 Finder charts
 - 504 pages, hardbound
- \$34.95**

Willmann-Bell

Get full details at Willbell.com

MEADE SCT UPGRADES
Improve focus, clutch, drives, light thru-put, mounting, carrying & balancing.



EZ BINOC MOUNT KIT
Outdoor mount handles all size binoculars. View standing, sitting or reclining. \$124.95



PETERSON ENGINEERING
www.petersonengineering.com 401-245-4068

Bob's Knobs
COLLIMATION THUMBSCREWS

Meade • Celestron • Astro-Tech • Sky-Watcher and more!

www.bobsknobs.com

Your Custom Adapter is just a few clicks away

HOT PRODUCT 2011 SKY



www.preciseparts.com
305.253.5707
info@preciseparts.com

PRECISEPARTS
CUSTOM PARTS FOR ASTRONOMY

shopatsky.com

BINOCULARS

Improved! **WideBino28**

2.3x40mm
28-degree FOV

"Dope" your eyes!

*Dealer inquiries welcome

www.kasai-trading.jp/widebino28e.html (Worldwide)
<http://agenaastro.com> (USA & Canada)



Get a globe!

shopatsky.com



CAMERAS

The best \$299 eyepiece you'll ever buy.

Just insert this camera into where your eyepiece normally goes, and you'll soon be "seeing" objects that are impossible to see the same way in your eyepiece! **Works in cities too.**
No computer required. Battery-powered 7-inch color monitor included.

Visit our website to see lots of cool new accessories that let you do even more!



HOT PRODUCT 2017 SKY TELESCOPE

Agena AstroProducts
High Point Scientific
Oceanside Photo & Telescope
Skies Unlimited
Woodland Hills Telescopes

DEALERS

REVOLUTION IMAGER
RevolutionImager.com

MISCELLANEOUS

THE NINE PLANETS RING
HANDCRAFTED WITH AN ORBITING GIBEON METEORITE BAND IN 18K GOLD SET WITH 9 GEMSTONES



NINEPLANETSRING.COM
831.336.1020

MOUNTS



ALT-AZ MOUNTS AND TRIPODS
"THE FASTER & EASIER WAY OUTSIDE"

- Extremely Rigid
- Silky Smooth even at 300 power
- Change eyepieces without re-balancing
- Designed from the start to use DSCs (no external cables or encoders)
- No counterweights or locks



WWW.DISCMOUNTS.COM
TOM@DISCMOUNTS.COM
954-475-8574

OBSERVATORIES/DOMES (continued)



OBSERVATORY SOLUTIONS

Sales - Project Management - Design
Installation - Training

WWW.OBSERVATORYSOLUTIONS.COM



Alfa Planetarium
Monterrey, Mexico



www.observa-dome.com

371 Commerce Park Drive, Jackson, MS 39213
Phone (601) 982-3333 • (800) 647-5364 • Fax (601) 982-3335
Mail@observa-dome.com

EYEPIECES

Legendary Brandon Eyepieces

Brandon eyepieces offer exceptional contrast against an extremely dark background.

Two reasons why every Questar sold since 1971 has included Brandon eyepieces. All are parfocal and every one of them is tested before being shipped. You'll be very pleased with these fine instruments!



1.25" 16mm
\$235

Vernonscope.com | 919-810-7168

OBSERVATORIES/DOMES

ASH-DOME



Simplicity of structure & ease of operation

www.ashdome.com



HOME-DOME AND PRO-DOME OBSERVATORIES



PROFESSIONAL DESIGN — AMATEUR PRICE

- ★ 6', 10' and 15' Diameter
- ★ Stand-alone or On Building
- ★ All Fiberglass
- ★ Easy Assembly
- ★ Manual/Computer Automated
- ★ Full Height/Handicap Access
- ★ Priced from \$3,750

CloudWatcher
Low cost, accurate system to detect cloud cover, light levels and first traces of rain. With DDW interface.
www.cloudetection.com

Call or write for a FREE Brochure
TECHNICAL INNOVATIONS
Phone: (407) 601-1975 www.homedome.com

Pod Max



12.5' Dome

www.skyshepodmax.com

SKY & TELESCOPE

ADVERTISE IN SKY & TELESCOPE MAGAZINE

CALL 773-551-0397 OR ADS@SKYANDTELESCOPE.COM

ORGANIZATIONS

Space is a dynamic and ever-changing mix of objects.

Observe variable stars and other dynamic celestial objects, then send us your data. We'll process and add what you've seen to our international database — which the global community of professional astronomers uses to aid their research.

Visit our website and learn more about how you can contribute — we could really use your help!



only you
can save
the night

www.darksky.org

SOFTWARE

Deep-Sky Planner 7

For visual and imaging observers



Exceptional
Planning & Logging
Software for Windows

Download the trial edition at
knightware.biz

TELESCOPES

ASTRO PHYSICS

Dedicated to
Craftsmanship!

1100GTO Auto-Adjusting Motor/Gearboxes
Absolute Encoder Option
12V DC

HOT PRODUCT 2014 SKY TELESCOPE

HOT PRODUCT 2017 SKY TELESCOPE

GTOCP4

Connectivity:

www.astro-physics.com
Machesney Park, IL USA
Ph: 815-282-1513

shopatsky.com

Performance.

made in the USA established 2003

Engineered Lightweight Mirrors,
Athermal Carbon Fiber Mirror
Mounts & Full Telescopes

dreamscopes.com 610-360-7874

TELESCOPE (continued)

JMI is now owned by
FARPOINTASTRO.COM

But Jim Burr can't
give up the New Next
Generation 8" Binos
How could he after 4 years of redesign?

See them at NEAF

Unbelievable views, amazing
design inter-ocular spacing.

New faster focusing design,
folding tripod. **\$4,995**

These will be the only ones
that will be made in the future.

**Last Chance to get a
Giant 14.5" Bino!**

One only - refurbished 14.5" Bino

Free crating and shipping
to lower 48 - **\$9,995**



303-233-5353 • info@jimsmobile.com

TRAVEL

TRAVELQUEST
international

Share in
the Wonder
as we journey to total
eclipses, aurora borealis &
dark-sky stargazing

TravelQuestTours.com
1 800 830-1998

CLASSIFIEDS

FOR SALE: Astro-Physics 180 mm EDT f9 Starfire refractor with guide scopes, assorted eyepieces, solar and other filters, and miscellaneous accessories. Further information, wallerfj@entermail.net

SOUTHWEST NEW MEXICO: Casitas de Gila Guesthouses. Dark skies, great accommodations; power, wifi, and pads available. casitasdegila.com/astronomy.html. 575-535-4455.

DARK SKY LAND FOR SALE: Adjoins Arizona Sky Village in Portal, Arizona. 5 acres \$15,000; 8 acres \$8,000; soldiercreekranch1990@gmail.com 530-279-2757

Classified ads are for the sale and purchase of noncommercial merchandise, one-of-a-kind items, or for job offerings. The rate is \$1.75 per word; minimum charge of \$28.00; payment must accompany order. Closing date is 10th of third month before publication date. Send ads to: Ad Dept., Sky & Telescope, 90 Sherman Street, Cambridge, MA 02140.



Only \$29!

You would be hard pressed to find a timepiece of this outstanding quality and precision at this price.

CLIENTS LOVE THE STAUER WATCH...



"The quality of their watches is equal to many that can go for ten times the price or more."

— Jeff from McKinney, TX

IT'S ENOUGH TO MAKE YOU BLUE IN THE FACE

Time to take a stand against overpriced watches with the Stauer Urban Blue, **now only \$29.**

You need a new watch...the one you are wearing was made when Nixon was in office, but extravagantly-priced watches that add zeros just because of a high falootin' name are an insult to your logic. Why shell out big money so some foreign company can sponsor another yacht race? It's time to put an end to such madness. It's absolutely possible to have the highest quality, precision classic timepiece without the high and mighty price tag. Case in point: The Stauer *Urban Blue*.

Packed with high-end watch performance and style, minus the high-end price tag. It's everything a high-end watch should be: Sturdy stainless steel and genuine leather construction. Precision timing that's accurate to four seconds a day—that's more precise than a 27-jewel automatic watch priced at over \$6,000. And, good looking—with simple, clean lines and a striking metallic blue face.

"Blue watches are one of the growing style trends seen in the watch world in the past few years"—WATCHTIME®

Your great escape from the over-priced watch craze.

At Stauer, we go directly to the source (cutting out the middleman), and engineer our own watch designs. This means we can offer a top quality timepiece that happens to only cost the same as two well-made cocktails at your favorite bar. So, while we're busy revolutionizing the

watch industry to bring you more real value, you can take your own stand against overpriced watches with the *Urban Blue*.

Your satisfaction is 100% guaranteed. Wear the *Urban Blue* for 30 days. If you're not convinced that you achieved excellence for less, send it back for a refund of the item price. The *Urban Blue* is one of our fastest sellers. It takes six months to engineer this watch so don't wait. Take a stand against overpriced watches in impeccable style.

Limited to the first 1900 responders to this ad only. Don't miss out...call today!

Stauer Urban Blue Watch ~~-\$199†~~

Offer Code Price **\$29** + S&P **Save \$170**

1-800-333-2045

Your Insider Offer Code: UBW273-02

You must use this insider offer code to get our special price.

Stauer®

14101 Southcross Drive W.,
Dept. UBW273-02
Burnsville, Minnesota 55337
www.stauer.com



† Special price only for customers using the offer code versus the price on Stauer.com without your offer code.

Precision movement • Stainless steel caseback and crown • Cotswold™ mineral crystal • Date window
• Water resistant to 3 ATM • Genuine leather band fits wrists 6 3/4"–8 3/4"

Stauer...Afford the Extraordinary.™

INSIDE This Issue

Specialty astronomy equipment dealers and manufacturers are an important resource for amateur and professional astronomers alike — patronize our advertising dealers in this issue and enjoy all the benefits of their expertise.

Product Locator

BINOCULARS

Meade Instruments Corp. (Cover 4)
Meade.com
800-919-4047 | 949-451-1450

CAMERAS

Finger Lakes Instrumentation (Page 1)
FLlcamera.com
585-624-3760

Meade Instruments Corp. (Cover 4)
Meade.com
800-919-4047 | 949-451-1450

EYEPIECES

Meade Instruments Corp. (Cover 4)
Meade.com
800-919-4047 | 949-451-1450

Tele Vue Optics, Inc. (Cover 2)
TeleVue.com
845-469-4551

FILTERS

Astro-Physics (Page 80)
Astro-Physics.com
815-282-1513

Finger Lakes Instrumentation (Page 1)
FLlcamera.com
585-624-3760

FILTERS (continued)

Meade Instruments Corp. (Cover 4)
Meade.com
800-919-4047 | 949-451-1450

Tele Vue Optics, Inc. (Cover 2)
TeleVue.com
845-469-4551

FOCUSERS

Finger Lakes Instrumentation (Page 1)
FLlcamera.com
585-624-3760

MOUNTS

Astro-Physics (Page 80)
Astro-Physics.com
815-282-1513

Meade Instruments Corp. (Cover 4)
Meade.com
800-919-4047 | 949-451-1450

Paramount (Cover 3)
Bisque.com
303-278-4478

Sky-Watcher USA (Page 5)
SkyWatcherUSA.com
310-803-5953

Tele Vue Optics, Inc. (Cover 2)
TeleVue.com
845-469-4551

OBSERVATORIES

Ash Manufacturing Co. (Page 79)
ashdome.com
815-436-9403

Observe-Dome Laboratories (Page 79)
Observe-Dome.com
800-647-5364 | 601-982-3333

SOFTWARE

Software Bisque (Cover 3)
Bisque.com
303-278-4478

TELESCOPES

Meade Instruments Corp. (Cover 4)
Meade.com
800-919-4047 | 949-451-1450

Sky-Watcher USA (Page 5)
SkyWatcherUSA.com
310-803-5953

Stellarvue® (Page 5)
Stellarvue.com
530-823-7796

Tele Vue Optics, Inc. (Cover 2)
TeleVue.com
845-469-4551

Dealer Locator

CALIFORNIA

Woodland Hills Telescopes (Page 40)
Telescopes.net
888-427-8766 | 818-347-2270

To advertise on this page, please contact Tim Allen at 773-551-0397, or Ads@skyandtelescope.com

AD INDEX

AAVSO 80
 Ash Manufacturing Co., Inc. 79
 Astro-Physics, Inc. 80
 DiscMounts 79
 Dreamscopes.com 80
 Finger Lakes Instrumentation, LLC 1
 International Dark-Sky Association 80
 iOptron 40
 JMI Telescopes 80
 Kasai Trading Co., Ltd. 78
 Kitt Peak National Observatory 69
 Knightware 80
 Land, Sea & Sky 69
 Lunatico Astronomia 78
 MALLICAM 3
 Meade Instruments Corp. Cover 4
 Metamorphosis Jewelry Design 79
 NEAF 2018 71
 Observa-Dome 79
 Observatory Solutions 79
 Peterson Engineering Corp. 78
 Preciseparts 78
 QHYCCD/Light Speed Vision Co., Ltd. 71
 Revolution Imager 79
 SAS 13
 Sky & Telescope 13,72, 73
 Sky Shed 79
 Sky-Watcher USA 5
 Software Bisque Cover 3
 Stauer 77, 81
 Stellarvue 13
 Technical Innovations 78, 79
 Tele Vue Optics, Inc. Cover 2
 TravelQuest International 80
 Vernonscope, LLC 79
 Willmann-Bell, Inc. 78
 Woodland Hills Telescopes 40

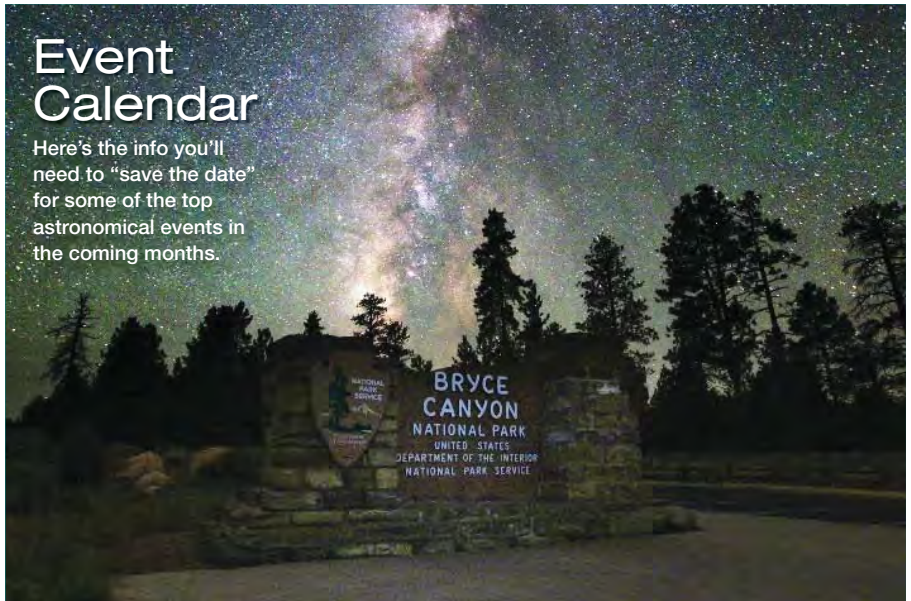

Event Calendar

Here's the info you'll need to "save the date" for some of the top astronomical events in the coming months.

April 15-21
INTERNATIONAL DARK SKY WEEK
 Everywhere!
darksky.org/dark-sky-week-2018

April 21-22
NORTHEAST ASTRONOMY FORUM
 Suffern, NY
rocklandastronomy.com/neaf.html

April 27-30
STARGAZE STAR PARTY
 Trap Pond State Park, DE
delmarvastargazers.org/star-party/star-gaze-xxv

April 21 (also October 13)
ASTRONOMY DAY
 Everywhere!
astroleague.org/astrologyday/facts

May 6-13
TEXAS STAR PARTY
 Fort Davis, TX
texasstarparty.org

May 18-20
MICHIANA STAR PARTY
 Vandalia, MI
michiana-astro.org/index.php/msp10

May 24-28
RTMC ASTRONOMY EXPO
 Big Bear City, CA
rtmcastronomyexpo.org

June 7-10
BOOTLEG SPRING STAR PARTY
 Harmon, IL
bootlegastronomy.com

June 14-17
CHERRY SPRINGS STAR PARTY
 Coudersport, PA
astrohbg.org/CSSP

June 9-16
GRAND CANYON STAR PARTY
 Grand Canyon, AZ
tucsonastronomy.org/upcoming-events/grand-canyon-star-party

June 13-16
BRYCE CANYON ASTRO FESTIVAL
 Bryce Canyon National Park, UT
is.gd/Bryce_Canyon_astrofest

June 13-17
ROCKY MOUNTAIN STAR STARE
 Gardner, CO
rmss.org

June 28 - July 3
RASC GENERAL ASSEMBLY
 Calgary, AB, Canada
rasc.ca/ga2018

July 11-14
ALCON 2018
 Minneapolis/St. Paul, MN
alcon2018.astroleague.org

• For a more complete listing, visit https://is.gd/star_parties.

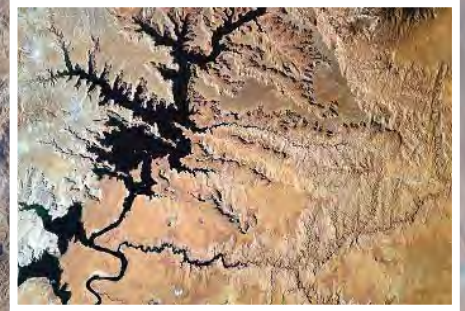

Armchair Astronaut

Always wanted to see Earth from space? Now you can, anytime, with a little help from NASA TV.

THE GREATEST SHOW on Earth is . . . the Earth.

It rolls by from about 400 km (250 miles) up, 24/7/365, thanks to four cameras NASA added to the International Space Station in 2014. Here is the vast Pacific Ocean, deep blue beneath scattered, puffy clouds. There are the Himalayas — which one is Everest? — and, 45 minutes later, the tangled coils of the Amazon.

You can soar over snow-white Canada in January, then return in June to see it brown and green with countless sparkling lakes. The continents and seas loom up at a steady pace as the ISS hurtles along at about 28,000 km/hour (17,000 mph). Every 90 minutes there's a sunset, with the horizon dimming and the clouds turning purple, then black. In another 45 there's a sunrise, the illuminated cloudtops gleaming impossibly bright.

Thanks to the ISS's orbit, the cameras eventually give us views of virtually every part of our planet between the poles. Log on and guess where you are: Is that the Indian Ocean down there?

Look, here comes China! There's desolation: Is it the Sahara — or perhaps the Australian Outback? Surely that broad river is the Mississippi!

NASA claims it mounted those cameras on the station's Columbus module to test how well they'd stand up to the harsh conditions of space. Maybe so, but the real grip of this free spectacle, accessible on computers and smartphones anywhere anytime, arises from the romance of spaceflight that has enthralled us for 57 years now, ever since those first puny rockets lifted men named Gagarin and Shepard toward the stars. For baby boomers in particular, the romance never quite died, even as we matured and began to see spaceflight as routine.

I could never have imagined as I sat in an eighth-grade classroom on May 5, 1961, for Alan Shepard's brief lob shot, that today approaching retirement I can effectively hop aboard the ISS and cruise around the globe, admiring it in living color. It was unimaginable even in the days of Mercury and Gemini and Apollo. The film from Ed White's Gem-

ini spacewalk gave us a glimpse, as did video from later Shuttle missions. But the really dramatic images came back to us from the Voyagers and Cassinis and Junos dispatched without humans to the outer planets, and from the rovers scurrying about on Mars.

As the show unreeles we can also silently remember those who died trying to further our exploration of space — the Apollo 1 and Soyuz 11 crews, and those who didn't make it up on *Challenger* or down on *Columbia*. Some of them had already seen that prospect from space, and they were willing to risk all to savor it again.

The ISS turns 20 this year. Some evenings as I read a book I log onto the live camera shot and glance up now and then to see where we are, and in those moments I am a passenger in spirit if not reality, sharing the latest step in our species' grandest adventure.

Check it out on NASA TV at <https://is.gd/ISSnasatv>. It truly is the greatest show on Earth.

■ **MIKE BRAKE**, a journalist, is also observing and outreach coordinator for the Oklahoma City Astronomy Club. He got his first telescope at age 10 in 1957.

Tame your imaging system.

Instant access to millions of celestial objects from standard and not-so-standard astronomical catalogs.

Hardware-accelerated graphics let you breeze through the night sky.

Extensive scripting and automation model can tailor functionality to achieve your research goals.

Web-updatable comets, asteroids, satellites, and field of view indicator databases.

Native telescope, camera, focuser, filter wheel and rotator control to simplify and optimize observatory device control.

Expandable feature set offers optional Dome, TPoint and Database Add Ons.



Customize the user interface to match your workflow.

All Sky Image Link offers lightning-fast plate solves with no internet access required.

Available for Mac or Windows operating systems (sold separately).



Master the universe with TheSky Professional Edition.

Choreographing your imaging system hardware to capture hours of digital exposures can be a daunting proposition. TheSky Professional seamlessly integrates astronomical device control in a single application to streamline workflow and optimize the productivity of your precious telescope time. Astrophotography is difficult enough. Let TheSky bridle your equipment to unleash your passion.

TheSky Professional Edition with the Camera Add On \$499

Optional Dome Add On \$249

Optional TPoint Add On \$249

Optional Database Add On \$219



THE SKY. THE LEADING ASTRONOMY SOFTWARE ON THIS PLANET OR ANY OTHER.

FIND YOUR SPACE

BISQUE.COM



© 2018 Software Bisque, Inc. 862 Brickyard Circle Golden, CO 80403 303.278.4478



MEADE® INSTRUMENTS

LX200 SERIES

Meade's LX200 is the most widely used advanced amateur telescope on Earth, it combines the most sophisticated optical system available with rock-solid mechanical and electronic elements to create the most versatile astronomical system around.

• PREMIUM OPTICS

All LX200 models come standard with Meade's Premium Advanced Coma-Free (ACF™) Optics paired with Ultra-High Transmission Coatings (UHTC™) which deliver razor sharp, high-contrast images that are perfect for viewing the night sky.

• SOLID FORK MOUNT

Solid and sturdy, the fork mount features fast slew speeds from 1 to 8 degrees per second, allowing you to observe more objects in a single night.

• AUTOSTAR® II

The LX200 includes the AutoStar® II handbox controller which puts over 140,000 objects at your fingertips and delivers the fastest Go-To performance available. This simple to use handbox provides complete control over every aspect of the telescope's operation.

THE MOST WIDELY USED, RESEARCH-GRADE, TELESCOPE SYSTEM

OPTIONAL WEDGES

The LX200 can be used as a high-performance instrument for both visual observing and astro-imaging. Meade offers optional wedges such as the 8" Equatorial Wedge and the X-Wedge which can convert the LX200 to an imaging platform capable of long-exposure photography of faint deep-sky objects.

LPI-G ADVANCED

Lunar, Planetary, Imager and Guider with USB 3.0. This new camera features a large image sensor along with a high pixel count that allows for increased resolution, making ideal for planets and solar imaging!

- COLOR AND MONOCHROME MODELS
- IMAGE SENSOR: CMOS -Sony IMX178
- PIXELS: 6.3 MP (3072 x 2048), 2.4µm square pixels
- FRAMES PER SECOND: 59 FPS @ full resolution using USB 3.0

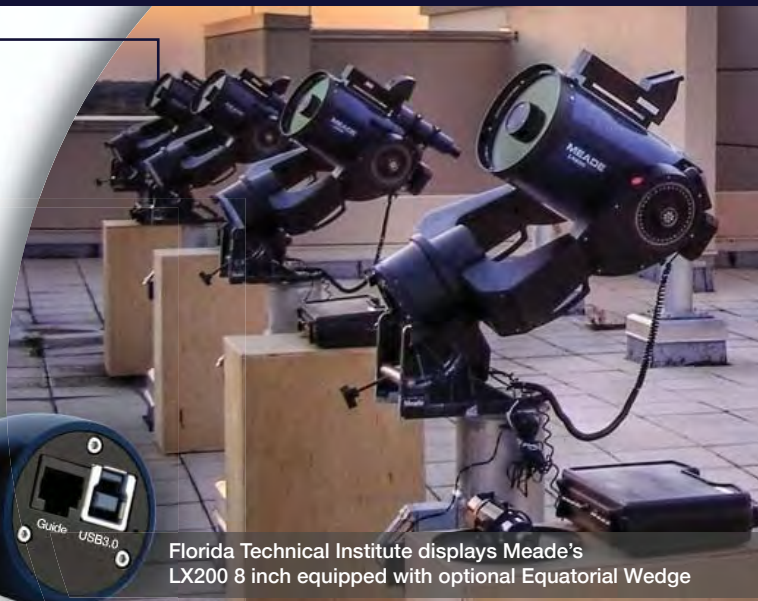

Florida Technical Institute displays Meade's LX200 8 inch equipped with optional Equatorial Wedge

Meade® US Blue Chip Dealers

Woodland Hills Camera | whcamera.com
Focus Camera | focuscamera.com
OPT Telescopes | optcorp.com
Optics Planet | opticsplanet.com

B&H Photo Video | bhphotovideo.com
Helix Camera & Video | helixcamera.com
High Point Scientific | highpointscientific.com
Astronomics | astronomics.com

meade.com

f MeadeInstruments
t MeadeInstruments
M MeadeInstruments