

(19)



(11)

EP 1 502 028 B1

(12)

EUROPEAN PATENT SPECIFICATION

(45) Date of publication and mention of the grant of the patent:
23.01.2008 Bulletin 2008/04

(51) Int Cl.:
F04C 19/00^(2006.01) F04C 27/00^(2006.01)

(21) Application number: **03756128.9**

(86) International application number:
PCT/NO2003/000128

(22) Date of filing: **16.04.2003**

(87) International publication number:
WO 2003/102423 (11.12.2003 Gazette 2003/50)

(54) **LIQUID RING COMPRESSOR**

FLÜSSIGKEITSRINGVERDICHTER

COMPRESSEUR A ANNEAU LIQUIDE

(84) Designated Contracting States:
AT BE BG CH CY CZ DE DK EE ES FI FR GB GR HU IE IT LI LU MC NL PT RO SE SI SK TR

(72) Inventor: **KAROLIUSSEN, Hilberg**
4950 Risor (NO)

(30) Priority: **19.04.2002 NO 20021844**

(74) Representative: **Axelsson, Nils Ake A.L. et al**
L.A. Groth & Co.KB,
Box 6107
102 32 Stockholm (SE)

(43) Date of publication of application:
02.02.2005 Bulletin 2005/05

(73) Proprietor: **Compressor Systems AS**
4876 Grimstad (NO)

(56) References cited:
WO-A1-95/17605 US-A- 4 747 752
US-A- 5 100 300 US-A- 5 251 593
US-A- 5 370 502 US-A- 5 395 215
US-A- 5 653 582

EP 1 502 028 B1

Note: Within nine months from the publication of the mention of the grant of the European patent, any person may give notice to the European Patent Office of opposition to the European patent granted. Notice of opposition shall be filed in a written reasoned statement. It shall not be deemed to have been filed until the opposition fee has been paid. (Art. 99(1) European Patent Convention).

Description

[0001] The present invention relates to a compressor, in particular a liquid ring compressor.

[0002] Most compressors work with approximate adiabatic process, i.e. without exchanging heat during the compression phase. In practice, e.g. a reciprocating compressor, emit quite a lot of heat, but it is only a small part of this heat which is emitted during compression, most of it is after, or in the end phase. A turbo compressor often has very close adiabatic process.

[0003] Some, a bit more special compressors can work very close to isothermal, i.e. the heat which is generated is continuously led away and the temperature is kept unchanged. Examples of these are water driven ejectors and liquid ring compressors, where both are frequently used with vacuum. A screw compressor with oil injection works polytropic, i.e. somewhere between adiabatic and isothermal.

[0004] The isothermal process requires less energy supplied than the adiabatic. The difference increase rapidly with increasing pressure difference, as shown in the diagram in figure 1. This shows theoretical values, calculated for air based upon formula for ideal gas. Air and gases which in a state which is not in the proximity of the critical point, behave very close to ideal.

[0005] For most objectives it is not desirable with hot gas after compression, and from this and the energy consumption, the isothermal process is preferred in theory.

[0006] When this, despite the above, is not employed today, the reason can be found in that existing isothermal or close isothermal compressors have too large hydraulic and dynamic losses. It is an exception for vacuum pumps which in reality is liquid compressors with high pressure difference, p_2/p_1 , but with little pressure height, p_2-p_1 . These can operate with low peripheral speeds on the liquid ring. Another problem is in the technical challenge to be able to remove heat continuously during compression.

[0007] Within vacuum both ejector and water ring compressors are frequently used. An ejector exploit the mass speed in a water jet in which the cross section expands and thereby can pull another medium with it. The ejector transform dynamic pressure to static pressure. However, an ejector system has relatively high losses in pump, in nozzle, by impact and friction. Ejectors are rarely used to anything else than the vacuum field. Within prior art the water ring compressor is closest to the compressor according to the present invention.

[0008] A liquid ring compressor consists mainly of an impeller which rotates eccentric in an outer enclosure together with a ring of water which the centrifugal force keeps in place against the periphery. The inlet is normally positioned as an opening in one or both of the end walls of the enclosure where the gas is drawn into the gaps of the impeller. Accordingly, it is arranged openings in the end walls on the pressure side, where the compressed gas is pushed out. All the types can have stationary com-

mutators arranged centrally within the rotor where inlet and discharge happens radially.

[0009] Liquid ring compressor does not transform the energy in the water in the same way as the ejector. The static pressure in the ring of water remains constant. The ring of water acts as a piston in every cell of the rotor. The principle for an ordinary liquid ring compressor is shown in figure 2, where a ring of liquid 23 rotates eccentric in a stationary enclosure 22, drive by a rotor 21 where the gap between the impeller will draw in gas on one side of a revolution and compress the gas on the other.

[0010] The static pressure in the ring of water has to be the same as the compression pressure, otherwise the water will be pressed out of the cell, i.e. the water ring will be deformed. Thereby it is given that a certain pressure height, p_2-p_1 , require a minimum centrifugal force. A liquid ring compressor usually has considerably higher pressure height and therefore requires higher speed of rotation than a vacuum pump.

[0011] The highest loss of friction in a conventional water ring compressor arise when the rotor is touching the wall of the enclosure. The clearing must here be very small, something which involves the water against the enclosure's periphery to have the same speed as the impeller tips of the rotor. Furthermore it must be very little clearance between the sides of the rotor and the enclosure. Also in these gaps there will be high frictions.

[0012] Generally the friction losses increase with a square of the speed increase, and in practice the water ring compressor loses level of energy in relation to energy in relation to an adiabatic compressor even at relatively low pressure ratios.

[0013] Without these friction losses, the liquid ring compressor has many advantages. It is very simple and can be one stage up to relatively high pressure ratios.

[0014] It is apparent that if that the enclosure around the ring of water rotated together with this, the hydraulic friction losses would be minimal. Thus, such a compressor would for normal pressure ratios could exploit the isothermal energy advantages almost in full.

[0015] An earlier suggestion disclosed with an outer, rotating cylinder tried to solve the problem of friction, without this leading to a feasible solution. US 5 100 300 and US 5 370 502 describes liquid ring compressor with a cylinder which floats on a film of liquid or gas between the cylinder and the outer stationary enclosure. By floating on a liquid film, it is doubtful whether it would be achieved any reduction in the friction, and with gas it would probably not be possible to achieve sufficient bearing capacity and stability, such that the cylinder do not touch the enclosure.

[0016] In a later patent, US 5 395 215, from the same firm, it is suggested a bearing of this cylinder in an outer enclosure, where a number of rollers are inserted in the wall of the enclosure where the cylinder is supported by the rollers. This do not seem realistic with the actual rotational speeds the rollers will achieve. A subsequent pat-

ent, US 5 653 582, returns back to fluids as the peripheral bearing for the rotating cylinder and suggestion to the basic solution.

[0017] US 5 251 593 discloses as the previous application that it is an intricate problem to get to, in relation to each other, eccentric bearings in combination with a stationary canals for the inlet and discharge of the gas. This publication indicates a bearing of the outer rotating cylinder on one side and the rotor on the opposite side, where a stationary plate close to the open end of the rotor has canals for inlet and discharge. It is mainly two decisive weaknesses with this design. The first is the one-sided bearing this solution gives, where the bearing load becomes uneven and too high. At the same time large axial thrust forces arise. The other weakness is the problems with achieving a reasonable gas tight sealing between the outer rotating cylinder, and the plate where the inlet and discharge canals are positioned in a circular plate, inlaid in the open end of the rotor. It would here be gas leaks backwards from cell and in addition out through the circular gap between the stationary plate and the rotor. The principle is unrealistic for practical purposes.

[0018] Despite many studies and suggestions over many years, it evidently has not been possible to reach a design which fulfil the requirements to function satisfactory. Thus at present there exists no liquid ring compressor with such co-rotating rotor. The above mentioned publications indicates that one has been tied up to the starting point for a rotor and communicator system like those in conventional vacuum pumps and compressors for relatively low pressure, with the above mentioned limitations in speed. This is reflected in relatively wide rotors with communicator on each side, which lead to long bearing distance and high bearing loads. In a compressor with liquid ring in the outer co-rotor, the geometry will be wrong, which will lead to bearing relationship which is unsuitable for existing bearing types. With communicator on each side it becomes four sections with gaps where there exists leakage from the zones on the pressure side.

[0019] The compressor according to the present invention has the objective to solve this problem which up to now has prevented a water ring compressor to exploit the above mentioned advantages with a co-rotor for the liquid ring. Another objective is to achieve almost isothermal compression with a new, very efficient direct injection of liquid into the gas during the whole compression stage.

[0020] Water as injection liquid has very good thermal properties, and is desirable to use with those gases which allow this. But, as for pumps and the like, the design for a liquid compressor with a co-rotor require a distinct division between water and the bearing of the co-rotor. From the development of screw compressors with water injection it is known and it has been problems with sealing on the pressure side of the screws. Firstly, water has small to little lubricating effect on the sealing which must have relatively high pressure towards the axle and therefore high wear. Furthermore, water penetrates easily

through even the finest gaps, and especially high pressure. Below it will be evident that the compressor according to the present invention solves the sealing problem by eliminating the reasons for them. The aforementioned objectives will be satisfied with the liquid ring compressor according to present invention as it is defined in the attached claims.

[0021] The invention will now be described, by way of example, with reference to the accompanying drawings, in which figure 1 shows a diagram with theoretical energy needs independence of pressure relation ship, figure 2 shows schematic the principle for a liquid ring compressor, figure 3 a liquid ring compressor according to the present invention in a divided longitudinal view, figure 4 is a cross section of figure 4, figure 5 shows the compressor as mounted, sectioned design, figure 6 shows details of the rotor, figures 7a and 7b shows details of the communicator, and figure 8 shows details of the bearing to the co-rotor, seals and the system for airing of the zones at the bearings.

[0022] The main parts in figure 3 consists of two enclosures 1 and 2, two co-rotors 3 and 4, a rotor 6 and a rotor axle 5, a communicator 7, two bearings 11 for co-rotors 3 and 4 and two bearings 12 for the rotor axle 5 as well as the axles 8 and 9 for the outer and inner bearings 12. On figure 4 a sector I-II with suction, a compression and injection sector II-III and a sector III-I for gas discharge in the clockwise direction. In the sector II-III liquid is injected from the communicator directly into the rotor cells and the compression and cooling of the gas in the cells.

[0023] With the largely reduced friction in the water ring due to the co-rotor, is it possible to make the rotor considerable narrower at the same time that the discharge volume is compensated with a considerable increase in speed. Thereby the inner pressure in the water ring is increased and the compressor can deliver with very high pressure.

[0024] A short rotor get little bending force from the gas pressure and is thereby allowed to be fixed to a flange on its axle only at one end wall and thereby being able to have a simple commutator in the entire width of the rotor. It is then only created two leakage gap between the commutator and the rotor. These gaps are the only place where leakage from the pressure side will find place. It can leak actually to both sides from the gap and along the periphery from the pressure discharge against the inlet, especially in the direction of rotation. Even in very small gaps, pure gas without liquid will with the present pressure be able to leak in considerable amounts, with smaller amounts deliver and lower efficiency as a result.

[0025] The surface of the rotor 6 on the inside towards the commutator is at its ends 63 smooth, with interweaving canal openings 62 to each individual cell. On figure 7a and 7b it is shown that the commutator has a row of grooves 71 in the opposite side sections. The grooves are under liquid pressure from the liquid canal 74 which

thereby is blocking for gas leakages in the actual direction.

[0026] The liquid ring compressor according to the present invention could be designed with hydro dynamic bearing for the co-rotor. These could then be lubricated and cooled with the same liquid which was used for injection. But with the starting point with necessary axle diameter and speed, research shows however that the friction losses in such bearings then will be very high and some of the advantages with a co-rotor are lost. With higher pressure the bearing size increases further and the losses in them become unacceptable.

[0027] On the other hand the same relationship seems to be acceptable for relatively large ball or roller bearings, but at the same time this leads to new problems around the bearing sealing. Bearings with integrated seals can not operate close to the necessary speeds and there do not exist any static seals which allows this, or that will achieve acceptable lifetime. Labyrinth seals however are touch-free and can operate with high speeds, but do not give any static sealing. These seals assume there are no differential pressures across the seal.

[0028] To prevent differential pressure across the bearing a co-rotor is aired to the compressor enclosure through the holes 81 as shown in figure 8. For air pressure compressors the enclosure is in turn aired to atmosphere or is by compression of other gases to prevent discharge, aired to the inlet, and thereby it will not be a differential pressure across the bearing of the co-rotor. Blocking liquid which leaks from the gap between the commutator and the rotor will during operation be projected out into the liquid ring and will not be able to reach the bearings for the co-rotor. Thus, the design only needs a static bearing seal during the stopping phase, where the danger for splashing water against the seals is apparent when the water ring collapses due to lack of centrifugal force. In conventional water ring compressors it is earlier known to be used lip seals as disclosed in US 4 747 752. In that case, however, it is dealt with a drive axle which has a relatively small diameter and low peripheral speed. As mentioned above the speed relationship for the co-rotor becomes critical with regards to wear.

[0029] This is led to the need for designing and completely new lip seal 82, shown in more detail in figure 8, which solves the problem in a relatively simple manner. The seal rotates together with the outer ring of the bearing 11. The lip 83 is relatively ductile and at standstill and under start and stop cycle it will rest against the axle and seal statically, but when the speed and centrifugal forces increases, it is projected outwards and get a clearance s_x so it does not touch the axle during operation. This is shown in the cross section A and B of figure 8.

[0030] It is evident that the lip during operation places itself against the edge of the openings in the co-rotor and walls so it is relatively small movements the lip bends from being in contact with the axle until it is not. This give little fatigue effect even with frequent start and stop.

[0031] The seal is in other words static at low speeds

and seems dynamic at higher speeds, where its purpose is only to prevent bearing grease to be projected out. Bearing of the co-rotor will with this system get about the same surrounding relationship and security as if they operated in air.

[0032] It is the diameter on the bearing of the rotor and the eccentricity between the rotors which decide the diameter on the bearing axles of the co-rotor because the bearing of the rotor as shown is inserted in these. The load on the bearing of the rotor becomes the same as for the co-rotor. To withstand this load, at the same time as giving smallest possible dimensions for the axle to the co-rotor, so-called needle bearings are used for the rotor. The purpose and the necessity by integrating the bearing of the rotor in the axle of the co-rotor, is to achieve short as possible bearing distance which give smallest axle diameter. For the bearing for this axle the peripheral speed allows ordinary static seals, and the bearing can be lubricated by oil.

[0033] To prevent the creating of trapped gas pockets in the cells of the rotor 61, are these as shown in figure 6, circular inwards towards the canal openings. Along the periphery of the commutator in the sector of this where the compression finds place, it is drilled a number of holes 75 which are in communication with the inner liquid canal 74 which has a pressure similar to the delivery pressure of the compressor. Through these holes liquid is injected directly into the cells of the rotor. These jets are hit of the rims of the inlet and discharge canals of the cells with high velocity and frequency, and the liquid pulverises so it is transformed into a liquid mist inside the cell. The mist is projected out towards the water ring, but is continuously renewed by new jets so there is a flow outwardly. The density of holes can increase towards the end of the compression sector to compensate for a falling differential pressure between the liquid and the gas.

[0034] The commutator is fixed to the one, stationary axle 8 for the co-rotor. The axle connects the canals of the commutator with the respective inlet and discharge for gas and injection liquid.

[0035] When the compressor according to the present invention is used for other gases than air, e.g. cooling system or in a petrochemical plant, it can be useful to use the actual gas in the liquid phase for injection and as liquid ring.

[0036] At an expected, reasonably lower energy need than for a turbo compressor the compressor will according to the present invention be very suitable as compressor in a gas turbine plant which operates with relatively high pressure relationship. The air from this will indeed in contrast to the turbo compressor, be cold, but it is necessary to note that the heat which the turbo compressor delivers is taken out of the axle of the turbine and reduces the output effect accordingly at the same time as the warm air to do not make it possible for heat recovery from the turbine exhaust. By use of the compressor according to the invention, the air from the compressor can be heat exchanged with the exhaust gas and almost reach the

same temperatures as after a turbine compressor.

Claims

1. Liquid ring compressor, **characterized by** an eccentric inner rotor (6) supported in axles (8, 9) to an outer co-rotor (3) for the liquid ring, the bearing of the co-rotors (11) being outside the same axles and is enclosed on each side in an enclosure where on each side of the bearing (11) a rotating lip seal (82) is arranged which the lip (83) of which lip seal (82) abuts the axles (8, 9) at low speed, and which lip (83) at high speed is projected out due to centrifugal forces and lifts itself from the axles, where through holes (81) through the co-rotor's sidewalls and bearing enclosure, being provided which volume within the liquid ring is aired to the surrounding enclosure (1), so that no differential pressure is created across the bearings and the seals of the bearings.
2. Compressor according to claim 1, **characterized by** that the rotor (6) in the periphery has a number of cells (61) with half cylindrical shape where the arc is turned towards the centre.
3. Compressor according to claim 1-2, **characterized by** the cells (61) of the rotor (6) has radial canal openings (62) on each side surrounded of a circular smooth section (63) for sealing against a stationary commutator (7) placed in the centre of the rotor.
4. Compressor according to claim 1-3, **characterized by** that it from hole (75) in the commutator (7) in the compression sector is injected liquid where liquid beams crush of the rims of the canal opening (62) to the cells (61) of the rotor.
5. Compressor according to claim 1-4, **characterized by** that the commutator (7) on each side has peripheral grooves (71), where injection liquid exist under pressure and inhibit gas leaks.
6. Compressor according to claim 1-5, **characterized by** that the periphery of the commutator (7) is outside the co-rotors bearing seals so that leaking water from the gap between the commutator and the rotor is projected out in the liquid ring without passing the bearing seals.
7. Compressor according to claim 1-6, **characterized by** that the bearings (11) for the co-rotor are of ball or roller bearings types.
8. Compressor according to claim 1-6, **characterized by** that bearings (11) are slide bearings, including hydrodynamic types.

9. Use of a compressor according to claim 1-8 as an air compressor and water compatible gasses where water is used as injection liquid.

- 5 10. Use of a compressor according to claim 1-9 as a compressor in a gas turbine plant.

Patentansprüche

- 10 1. Flüssigkeitsringkompressor, **gekennzeichnet durch** einen Exzenterinnenrotor (6), der auf Achsen (8, 9) eines Ko-Rotors (3) für den Flüssigkeitsring aufgenommen ist, wobei das Lager des Ko-Rotors (11) außerhalb derselben Achsen liegt und auf jeder Seite in einer Umhüllung eingeschlossen ist, wobei auf jeder Seite des Lagers (11) eine rotierende Dichtlippe (82) angeordnet ist, wobei die Lippe (83) von dieser Dichtlippe (82) bei niedriger Geschwindigkeit an den Achsen (8, 9) anliegt, und wobei die Lippe (83) bei hoher Geschwindigkeit nach außen hervorstehend wird und sich infolge von Zentrifugalkräften selbst von den Achsen abhebt, wobei Durchgangslöcher (81) **durch** die Seitenwände des Ko-Rotors angeordnet sind und Lager vorgesehen sind, deren Volumen innerhalb des Flüssigkeitsrings gegenüber der einschließenden Hülle (1) belüftet ist, so dass kein Differenzdruck zwischen den Lagern und den Dichtungen der Lager erzeugt wird.
- 15 2. Kompressor nach Anspruch 1, **dadurch gekennzeichnet, dass** der Rotor (6) an seiner Peripherie eine Anzahl von Zellen (61) mit halbzylindrischer Form aufweist, wobei der Bogen der Mitte zugewandt ist.
- 20 3. Kompressor nach Anspruch 1 bis 2, **dadurch gekennzeichnet, dass** die Zellen (61) des Rotors (6) radiale Kanalöffnungen (62) aufweisen, die auf jeder Seite von einem kreisförmigen, glatten Abschnitt (63) umgeben sind, zwecks Abdichtung gegenüber einem stationären Kommutator (7), der in der Mitte des Rotors platziert ist.
- 25 4. Kompressor nach Anspruch 1 bis 3, **dadurch gekennzeichnet, dass** von dem Loch (75) in dem Kommutator (7) in dem Kompressionssektor Flüssigkeit injiziert wird, wo die Flüssigkeitsstrahlen von den Rändern der Kanalöffnung (62) zu den Zellen (61) des Rotors ausquetschen.
- 30 5. Kompressor nach Anspruch 1 bis 4, **dadurch gekennzeichnet, dass** der Kommutator (7) auf jeder Seite Umfangsnuten (71) aufweist, wobei Injektionsflüssigkeit unter Druck existiert und Gasleckagen entgegengewirkt wird.
- 35 6. Kompressor nach Anspruch 1 bis 5, **dadurch ge-**
- 40
- 45
- 50
- 55

kennzeichnet, dass die Peripherie des Kommutators (7) außerhalb der Lagerdichtungen des Ko-Rotors sind, so dass eine Leckage von Wasser aus dem Spalt zwischen dem Kommutator und dem Rotor aus dem Flüssigkeitsring ausgeleitet wird, ohne die Lagerdichtungen zu passieren.

7. Kompressor nach Anspruch 1 bis 6, **dadurch gekennzeichnet, dass** Lager (11) für den Ko-Rotor von der Art von Kugellagern oder Rollenlagern sind.
8. Kompressor nach Anspruch 1 bis 6, **dadurch gekennzeichnet, dass** die Lager (11) Seitenlager sind, wozu hydrodynamische Arten gehören.
9. Verwendung eines Kompressors gemäß einem der Ansprüche 1 bis 8 als einen Kompressor für Luft und Gasen die mit Wasser kompatibel sind, bei denen Wasser als Injektionsflüssigkeit verwendet wird.
10. Verwendung eines Kompressors gemäß Anspruch 1 bis 9 als einen Kompressor in einer Gasturbinenanordnung.

Revendications

1. Compresseur à anneau liquide, **caractérisé par** un rotor intérieur excentrique (6) supporté au niveau des axes (8, 9) dans un co-rotor extérieur (3) pour l'anneau liquide, le palier des co-rotors (11) étant situé à l'extérieur des mêmes axes et enfermé de chaque côté dans une enceinte où un joint à lèvre rotatif (82) est disposé de part et d'autre du palier (11), ladite lèvre (83) dudit joint à lèvre (82) vient en contact avec les axes (8, 9) à faible vitesse et ladite lèvre (83) fait saillie à grande vitesse en raison de forces centrifuges et se soulève des axes, des trous traversants (81) étant prévus à travers les parois latérales du co-rotor et l'enceinte du palier, lequel volume à l'intérieur de l'anneau liquide est évacué vers l'enceinte (1) qui l'entoure de sorte à ne pas générer de pression différentielle à travers les paliers et les joints des paliers.
2. Compresseur selon la revendication 1, **caractérisé en ce que** le rotor (6) présente au niveau de la périphérie un certain nombre de cellules (61) de forme demi-cylindrique, l'arc étant tourné vers le centre.
3. Compresseur selon les revendications 1 à 2, **caractérisé en ce que** les cellules (61) du rotor (6) présentent des ouvertures de canal radiales (62) de chaque côté entourées par une section lisse circulaire (63) permettant d'assurer l'étanchéité avec un commutateur stationnaire (7) placé au centre du rotor.

4. Compresseur selon les revendications 1 à 3, **caractérisé en ce que** du liquide est injecté depuis le trou (75) dans le commutateur (7) dans la zone de compression, des jets de liquide sortant des rebords de l'ouverture de canal (62) vers les cellules (61) du rotor.
5. Compresseur selon les revendications 1 à 4, **caractérisé en ce que** le commutateur (7) présente de chaque côté des rainures périphériques (71), dans lesquelles du liquide d'injection est sous pression et empêche les fuites de gaz.
6. Compresseur selon les revendications 1 à 5, **caractérisé en ce que** la périphérie du commutateur (7) est à l'extérieur des joints de palier des co-rotors de sorte que l'eau s'échappant de l'espace entre le commutateur et le rotor est projetée dans l'anneau liquide sans passer par les joints de palier.
7. Compresseur selon les revendications 1 à 6, **caractérisé en ce que** les paliers (11) pour le co-rotor sont des paliers de type à bille ou à rouleau.
8. Compresseur selon les revendications 1 à 6, **caractérisé en ce que** des paliers (11) sont des paliers lisses, y compris de type hydrodynamique.
9. Utilisation d'un compresseur selon les revendications 1 à 8, comme compresseur d'air et de gaz compatibles avec l'eau, l'eau étant utilisée comme liquide d'injection.
10. Utilisation d'un compresseur selon les revendications 1 à 9, comme un compresseur dans une installation de turbine à gaz.

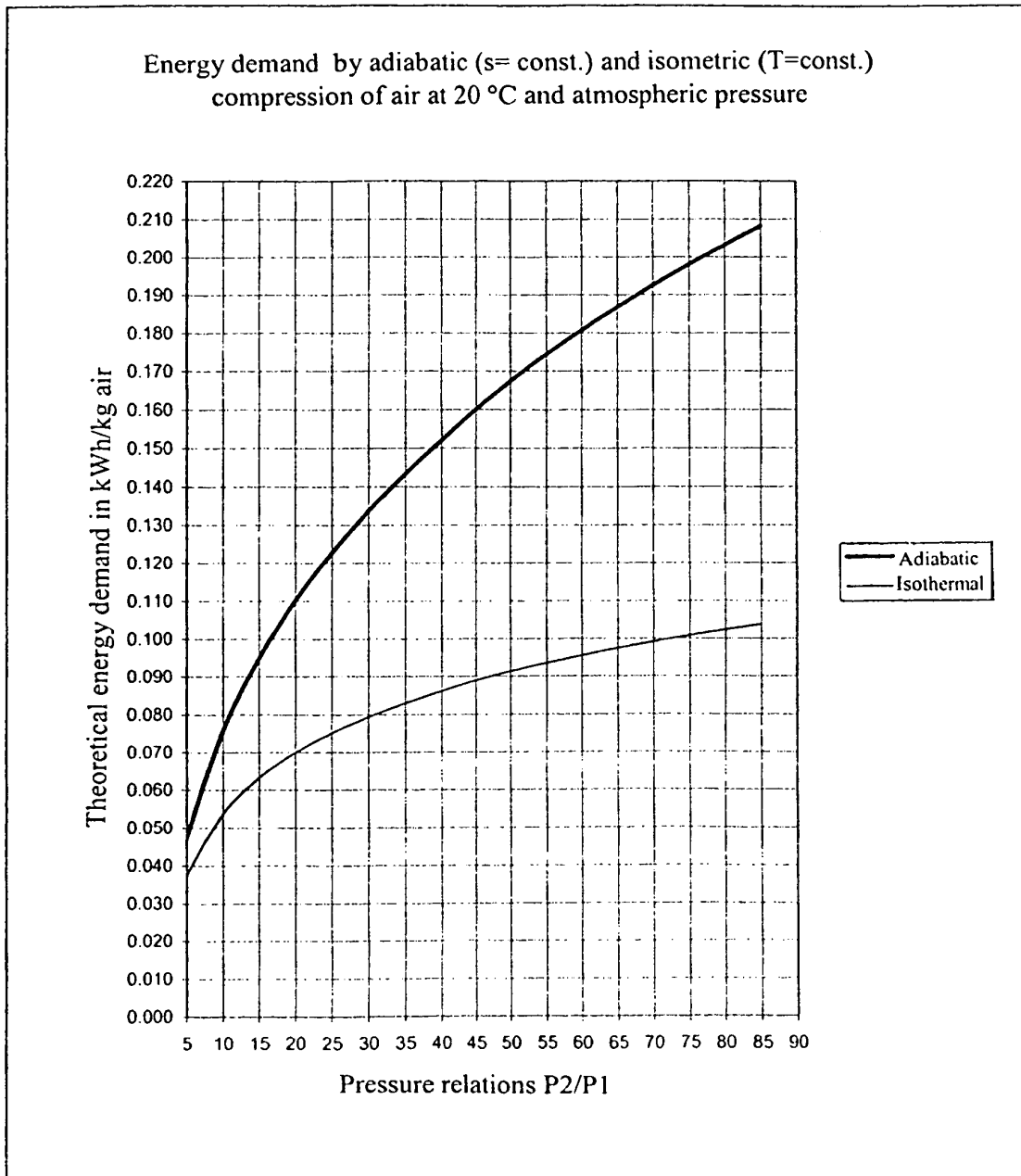

Fig. 1

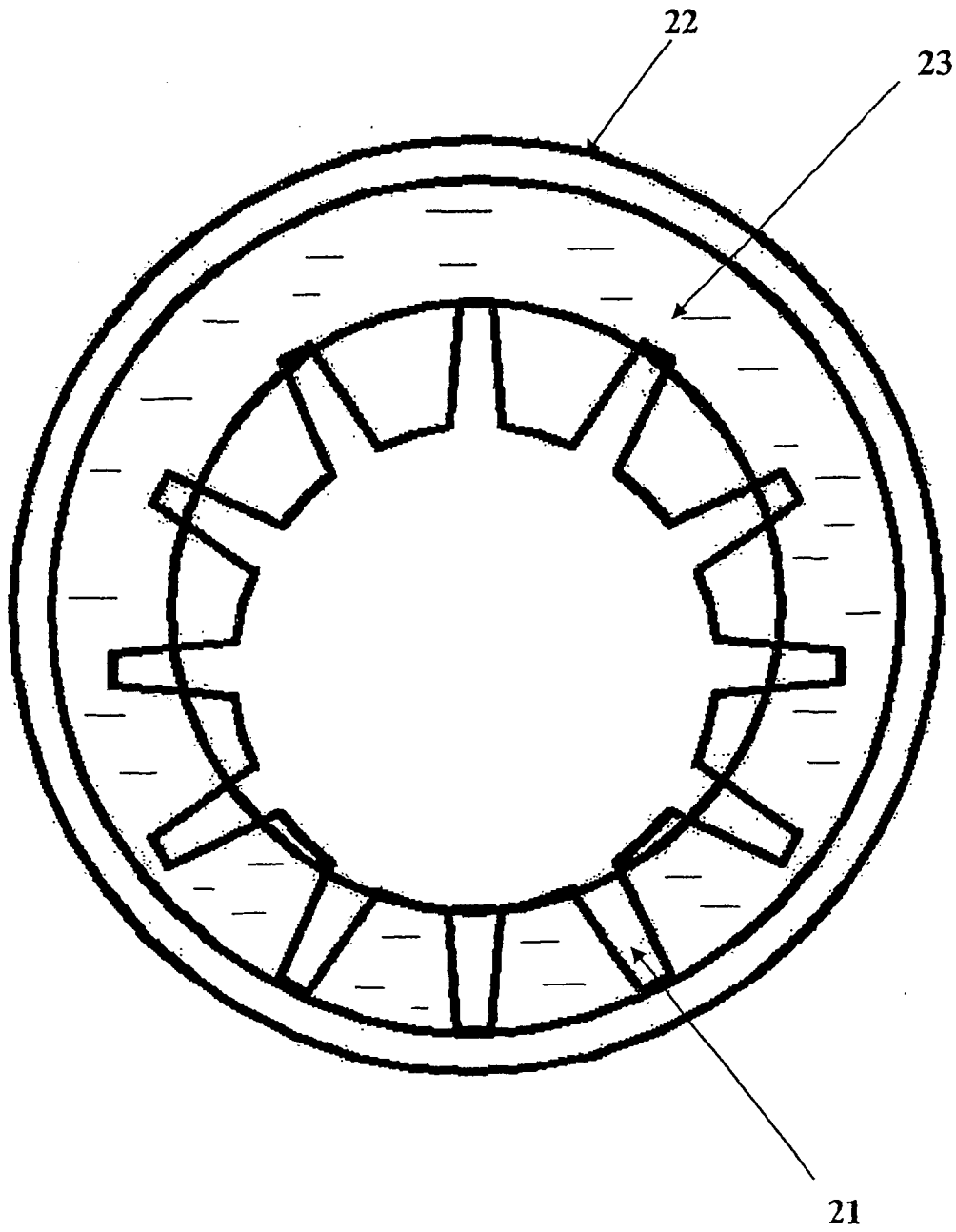

Fig. 2

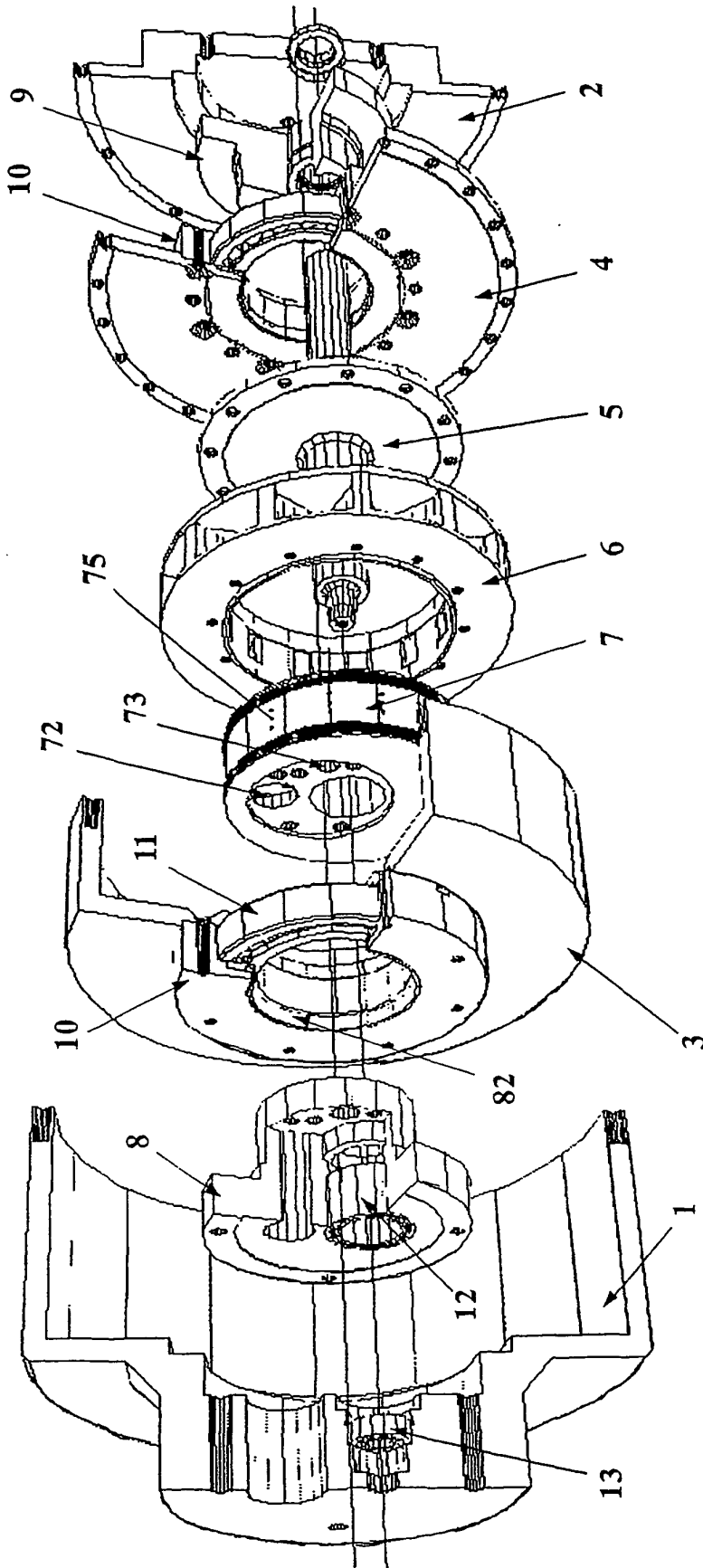

Fig. 3

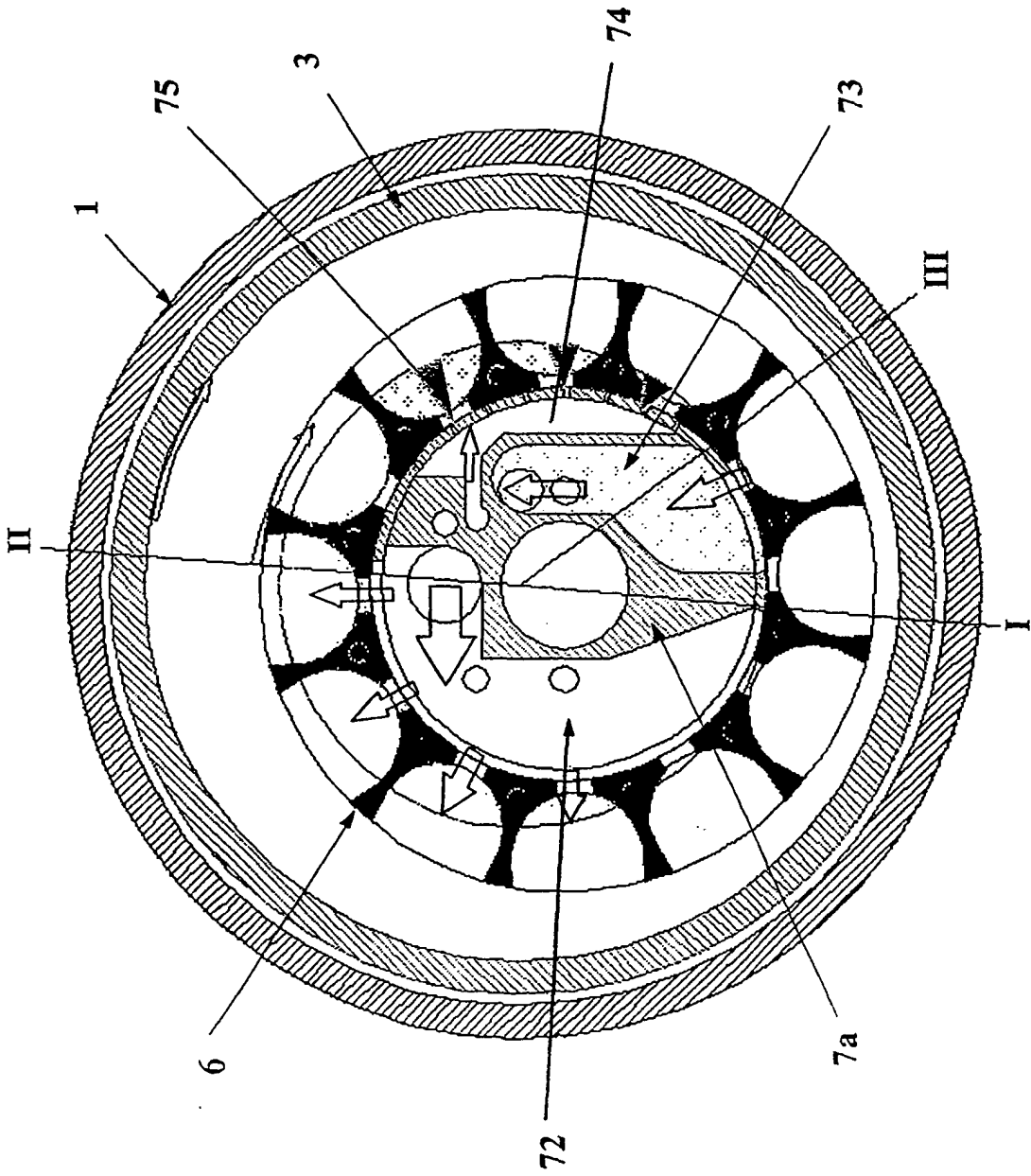

Fig. 4

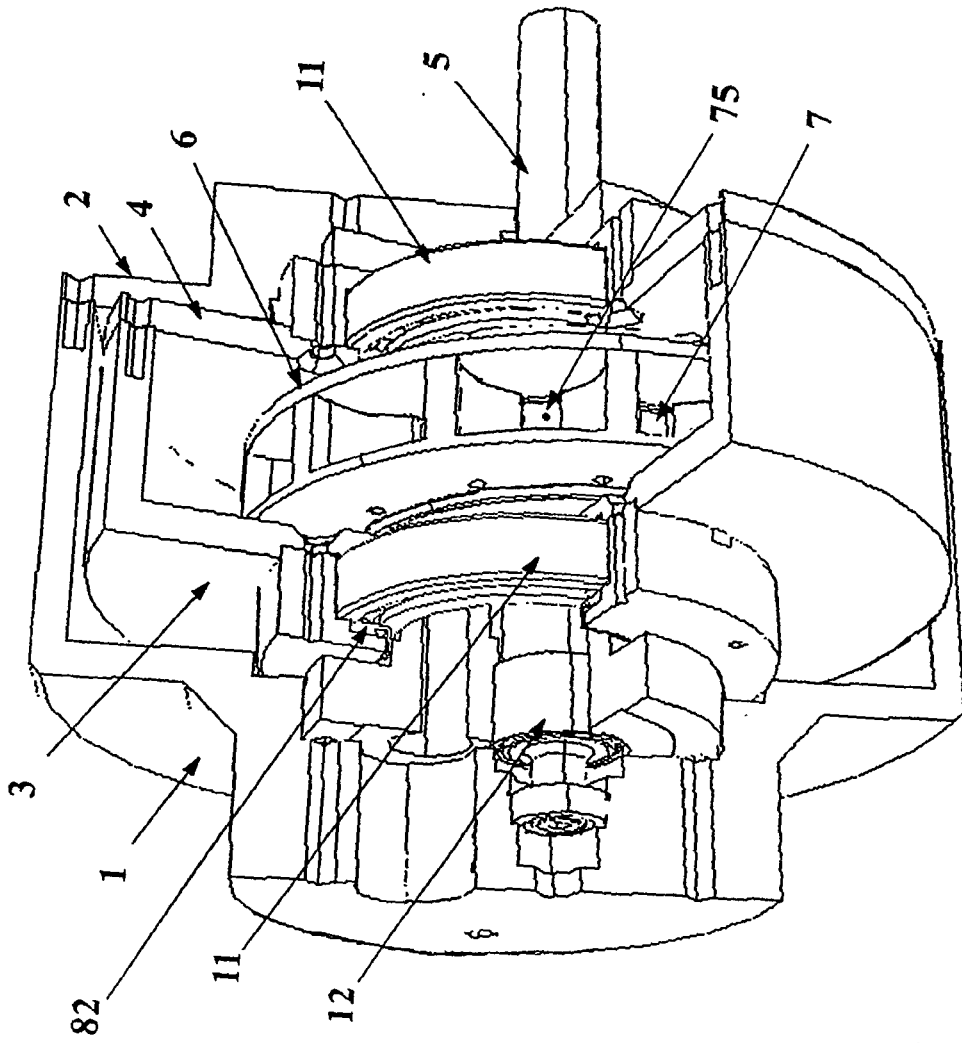

Fig. 5

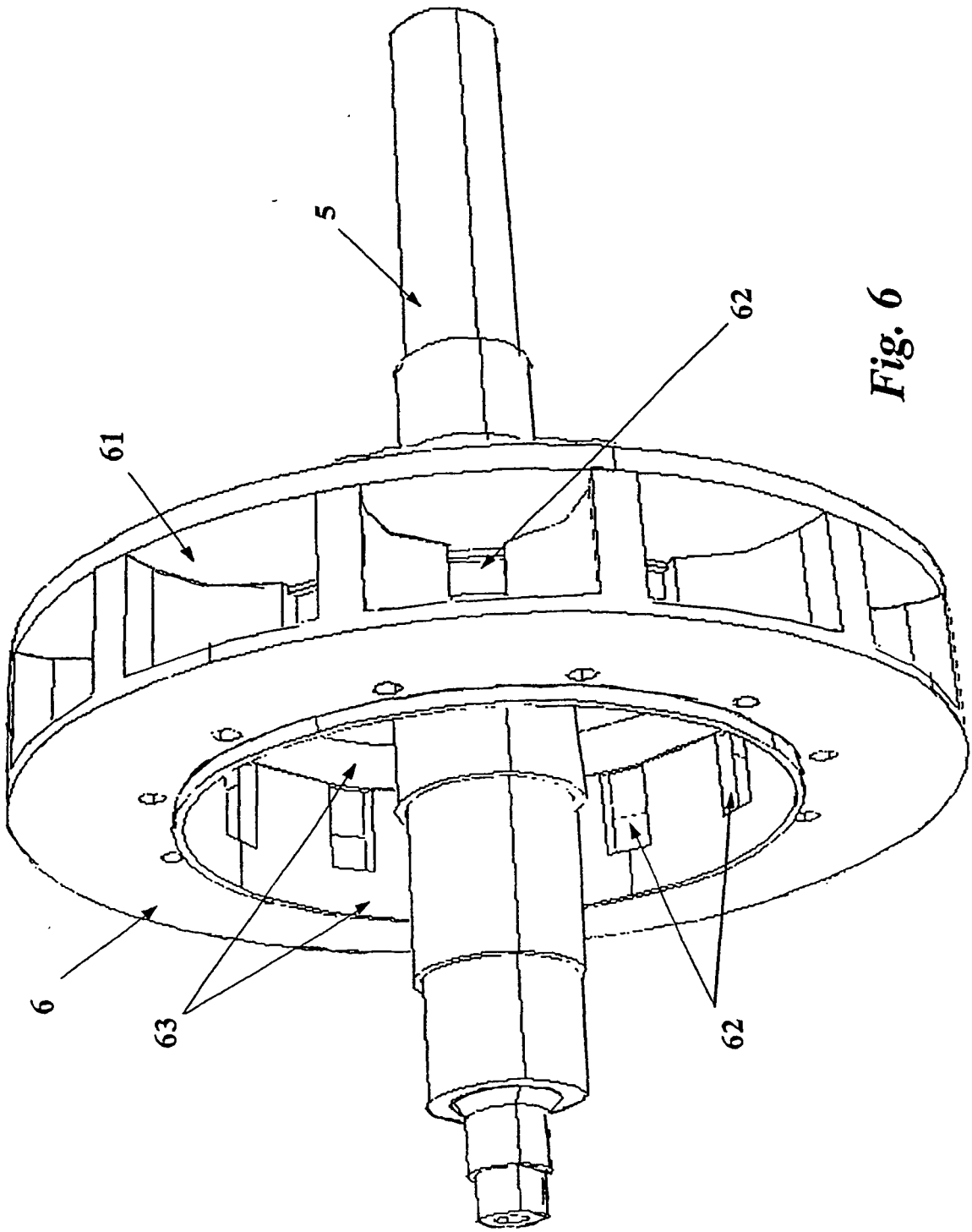

Fig. 6

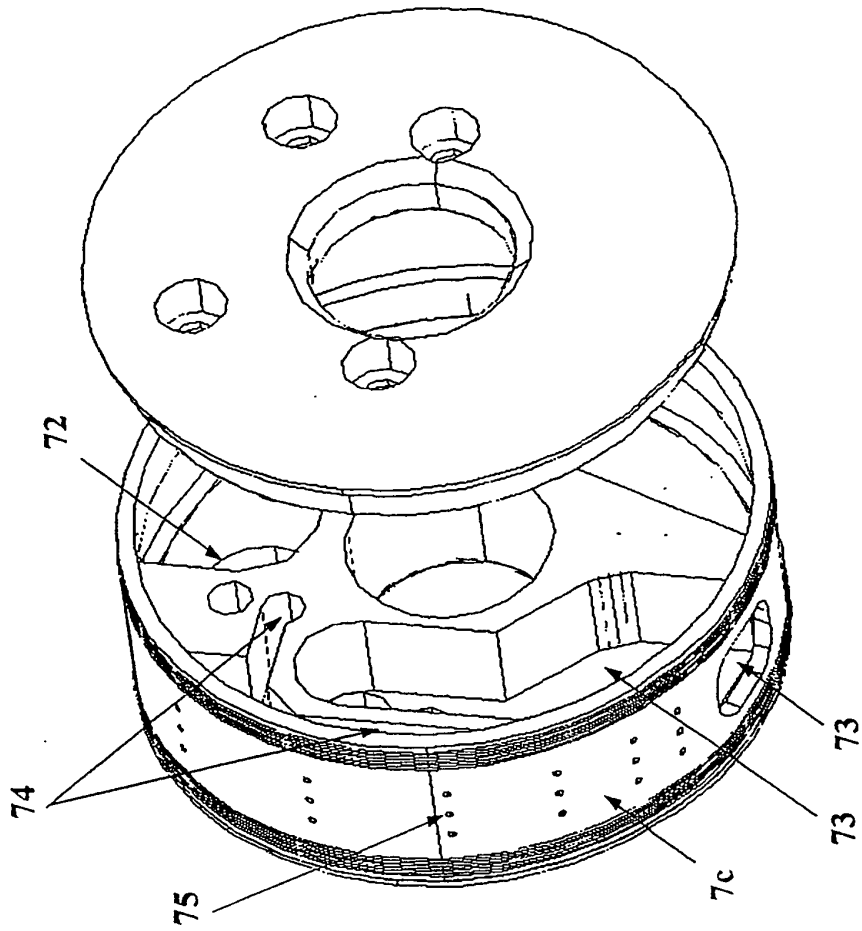

Fig. 7b

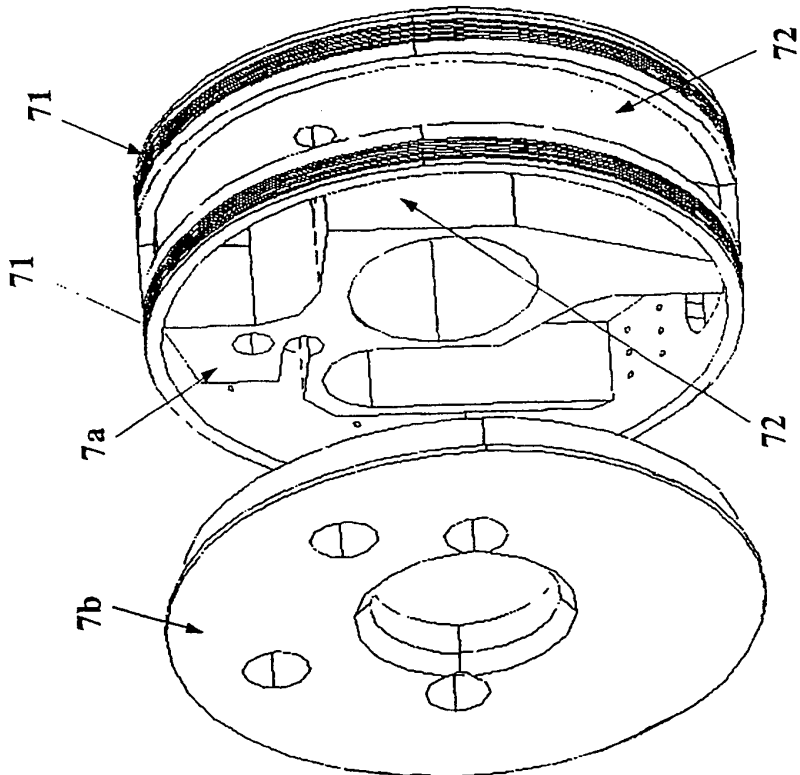

Fig. 7a

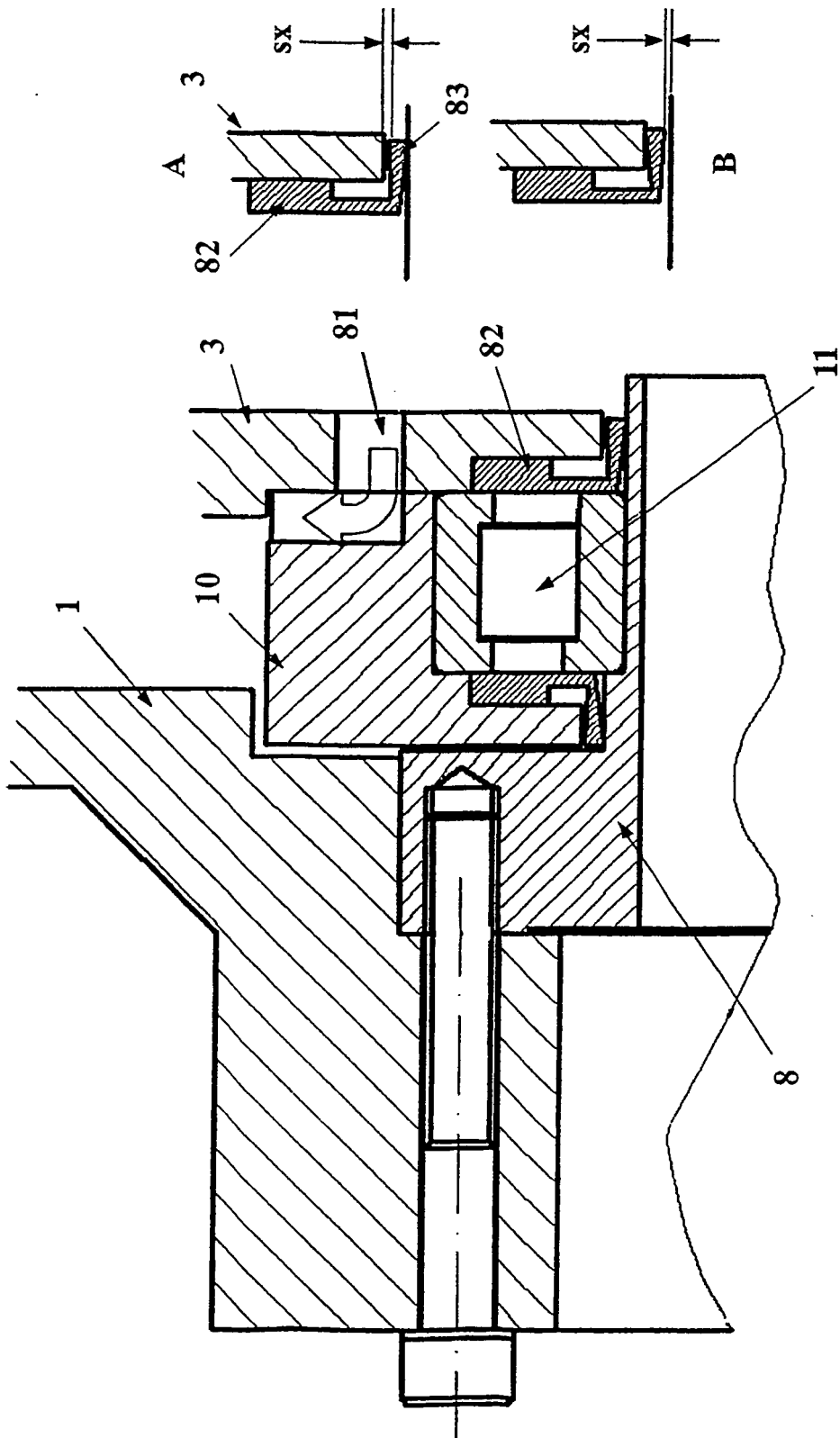

Fig. 8

REFERENCES CITED IN THE DESCRIPTION

This list of references cited by the applicant is for the reader's convenience only. It does not form part of the European patent document. Even though great care has been taken in compiling the references, errors or omissions cannot be excluded and the EPO disclaims all liability in this regard.

Patent documents cited in the description

- US 5100300 A [0015]
- US 5370502 A [0015]
- US 5395215 A [0016]
- US 5653582 A [0016]
- US 5251593 A [0017]
- US 4747752 A [0028]