

Hassco

Integral Contained Tanks

Double-Wall

1. Lockable Overfill Box c/w fill
2. 2" Threaded Fitting
3. Lift Lug
4. ULC Label
5. Emergency Vent
6. Legs
7. 1" Drain (NPT) Plugged
8. 2" Inspection Port

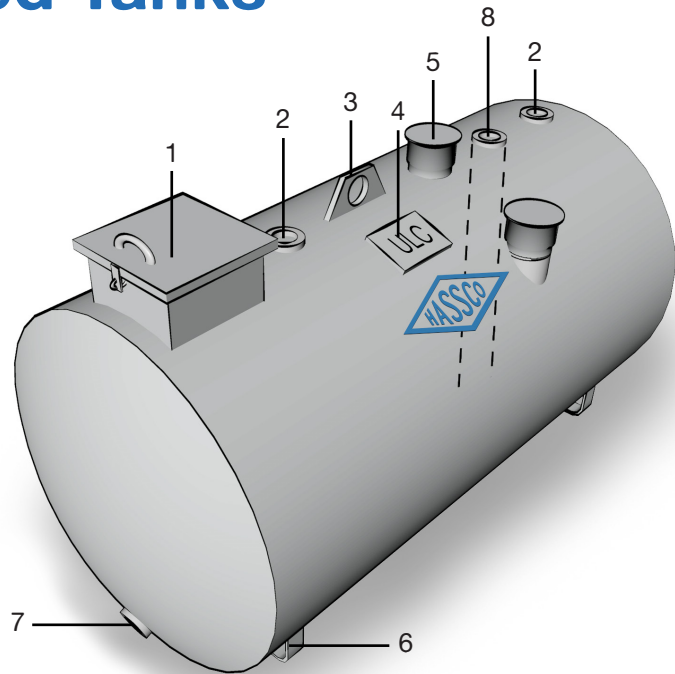

Material (gauge)	Capacity	Diameter	Length	Weight
12	450L/100G	30"	48"	450lbs.
12	1100L/250G	38"	60"	700lbs.
12	1360L/300G	38"	72"	750lbs.
12	2200L/500G	50"	72"	1070lbs.
12	4500L/1000G	50"	144"	1980lbs.

General Information

HASSCO's Contained Tank is a dual wall tank that meets all secondary containment requirements without vacuum monitoring. Best suited for applications where vacuum monitoring may not be ideal and applications where tanks might be moved from site to site. These tanks are industry proven, and are the latest, easiest way to store various fresh fuels. All HASSCO tanks are phosphate washed prior to applying a high build metal treatment and two top coats of enviro-smart water based paint. Other coating options such as epoxy and powder are available upon request.

Options

- Tank gauges, alarms, heaters and pumping systems
- Powder Coating
- Interior linings
- Contact HASSCO for options on tanks larger than 4500L
- Available in custom sizes and configurations

Sizing

- Up to 60 000L/13 000G

Conformity

- ULC S601

