

**ENVIRONMENTAL ASSESSMENT FOR THE
OPERATION AND LAUNCH OF THE FALCON 1 AND
FALCON 9 SPACE VEHICLES
AT
CAPE CANAVERAL AIR FORCE STATION
FLORIDA**

**PREPARED FOR
SPACE EXPLORATION TECHNOLOGIES CORPORATION
EI SEGUNDO, CALIFORNIA**

**AND
45 SPACE WING
PATRICK AIR FORCE BASE, FLORIDA**

**PREPARED BY
AEROSTAR ENVIRONMENTAL SERVICES, INC.
ORLANDO, FLORIDA**

November, 2007

TABLE OF CONTENTS

TABLE OF CONTENTS	i
LIST OF FIGURES	v
LIST OF TABLES	vi
LIST OF APPENDICIES	vii
ACRONYMS AND ABBREVIATIONS	viii
1.0 PURPOSE AND NEED FOR THE PROPOSED ACTION	1-1
1.1 Introduction	1-1
1.2 Location and Background	1-1
1.3 Purpose and Need for Action	1-2
1.4 Scope of the Environmental Assessment	1-3
1.4.1 Future Use of this Document	1-3
1.4.2 Structure of the EA	1-4
1.5 Regulatory Requirements and Coordination	1-4
2.0 DESCRIPTION OF THE PROPOSED ACTION AND ALTERNATIVES	2-1
2.1 Description of Proposed Action	2-1
2.1.1 Operation Phase	2-2
2.1.2 Refurbishment and Construction Phase	2-12
2.2 Description of Alternatives Considered	2-13
2.2.1 Alternative 1: Use of SLC 36	2-13
2.2.2 Alternative 2: Use of SLC 47	2-14
2.2.3 No Action Alternative	2-14
2.2.4 Alternatives Considered/Eliminated from Further Consideration	2-14
3.0 AFFECTED ENVIRONMENT	3-1
3.1 Land Use Zoning/Visual Resources	3-1
3.1.1 Regional Land Use and Zoning	3-1
3.1.2 CCAFS Land Use and Zoning	3-2
3.1.3 Coastal Zone Management	3-2
3.2 Noise	3-3
3.2.1 General Description	3-3
3.2.2 Ambient Noise Levels	3-5
3.2.3 Operations-Based Noise	3-5
3.2.4 Refurbishment and Construction-Related Noise	3-7
3.3 Biological Resources	3-8
3.3.1 Invasive Species	3-8
3.3.2 Native Vegetation Communities	3-8
3.3.3 Threatened and Endangered Species of Special Concern	3-9

TABLE OF CONTENTS – Cont.

3.3.4	Migratory Birds	3-14
3.3.5	Wetlands and Floodplains	3-15
3.3.6	Marine Wildlife and Essential Fish Habitat	3-16
3.4	Cultural Resources	3-17
3.4.1	Regulatory Framework	3-17
3.4.2	Prehistoric and Historic Archaeological Resources	3-17
3.4.3	Historic Buildings and Structures	3-18
3.4.4	Native Populations/Traditional Resources	3-18
3.4.5	Cultural Resources Associated with SLCs 40,36A and B, 47	3-18
3.5	Air Quality	3-19
3.5.1	Lower Atmosphere	3-19
3.5.2	Upper Atmosphere	3-24
3.6	Orbital Debris	3-24
3.6.1	Characteristics of Orbital Debris	3-25
3.6.2	Hazards to Space Operations from Debris	3-25
3.7	Hazardous Materials/Hazardous Waste	3-25
3.7.1	Hazardous Materials Management	3-25
3.7.2	Hazardous Waste Management	3-27
3.7.3	Installation Restoration Program	3-27
3.7.4	Pollution Prevention	3-30
3.8	Water Resources	3-30
3.8.1	Surface Water	3-31
3.8.2	Ground Water	3-31
3.9	Geology and Soils	3-32
3.9.1	Geology	3-32
3.9.2	Topography and Soils	3-32
3.10	Transportation	3-33
3.10.1	General Area Network Description	3-33
3.10.2	On-Site Transportation	3-36
3.11	Utilities	3-37
3.11.1	Water Supply	3-37
3.11.2	Solid Waste Management	3-37
3.11.3	Electrical Power	3-37
3.12	Health and Safety	3-38
3.12.1	Regional Safety	3-38
3.12.2	On-Station Safety	3-38
3.13	Socioeconomics	3-41
3.14	Environmental Justice	3-41
4.0	ENVIRONMENTAL CONSEQUENCES	4-1
4.1	Land Use Zoning/Visual Resources	4-2
4.1.1	Proposed action – SLC 40	4-2

TABLE OF CONTENTS – Cont.

4.1.2	Alternative 1 – SLCs 36 A and 36 B	4-2
4.1.3	Alternative 2 – SLC 47	4-3
4.1.4	No-Action Alternative	4-3
4.2	Noise	4-3
4.2.1	Proposed Action – SLC 40	4-4
4.2.2	Alternative 1 – SLCs 36 A and 36 B	4-8
4.2.3	Alternative 2 – SLC 47	4-8
4.2.4	No-Action Alternative	4-8
4.3	Biological Resources	4-8
4.3.1	Proposed Action – SLC 40	4-9
4.3.2	Alternative 1 – SLCs 36 A and 36 B	4-13
4.3.3	Alternative 2 – SLC 47	4-13
4.3.4	No-Action Alternative	4-14
4.3.5	Cumulative Impacts	4-15
4.4	Cultural Resources	4-15
4.4.1	Proposed Action – SLC 40	4-15
4.4.2	Alternative 1 – SLCs 36 A and 36B	4-15
4.4.3	Alternative 2 – SLC 47	4-15
4.4.4	No-Action Alternative	4-16
4.5	Air Quality	4-16
4.5.1	Proposed Action – SLC 40	4-16
4.5.2	Alternative 1 - SLCs 36 A and 36 B	4-24
4.5.3	Alternative 2 – SLC 47	4-25
4.5.4	No-Action Alternative	4-25
4.5.5	Cumulative Impact Reductions	4-25
4.6	Orbital Debris	4-26
4.6.1	Falcon Orbital and Reentry Debris	4-26
4.6.2	Falcon Launch Vehicle Impacts	4-27
4.7	Hazardous Materials/Hazardous Waste	4-27
4.7.1	Proposed Action – SLC 40	4-27
4.7.2	Alternative 1 – SLCs 36 A and 36 B	4-32
4.7.3	Alternative 2 – SLC 47	4-32
4.7.4	No-Action Alternative	4-32
4.8	Water Resources	4-32
4.8.1	Proposed Action – SLC 40	4-32
4.8.2	Alternative 1 – SLCs 36 A and 36 B	4-34
4.8.3	Alternative 2 – SLC 47	4-34
4.8.4	No-Action Alternative	4-34
4.8.5	Cumulative Impacts	4-35
4.9	Geology and Soils	4-35
4.9.1	Proposed Action	4-35
4.9.2	Alternative 1 – SLCs 36 A and 36 B	4-35
4.9.3	Alternative 2 – SLC 47	4-35

TABLE OF CONTENTS – Cont.

4.9.4	No-Action Alternative	4-36
4.10	Transportation	4-36
4.10.1	Proposed Action – SLC 40	4-36
4.10.2	Alternative 1 – SLCs 36 A and 36 B	4-37
4.10.3	Alternative 2 – SLC 47	4-37
4.10.4	No-Action Alternative	4-37
4.11	Utilities	4-37
4.11.1	Proposed Action – SLC 40	4-37
4.11.2	Alternative 1 – SLCs 36 A and 36 B	4-39
4.11.3	Alternative 2 – SLC 47	4-39
4.11.4	No-Action Alternative	4-39
4.12	Health and Safety	4-40
4.12.1	Proposed Action – SLC 40	4-40
4.12.2	Alternative 1 – SLCs 36 A and 36 B	4-42
4.12.3	Alternative 2 – SLC 47	4-42
4.12.4	No-Action Alternative	4-42
4.13	Socioeconomics	4-42
4.13.1	Proposed Action – SLC 40	4-42
4.13.2	Alternative 1 – SLCs 36 A and 36 B	4-43
4.13.3	Alternative 2 – SLC 47	4-43
4.13.4	No-Action Alternative	4-43
4.14	Environmental Justice	4-43
4.14.1	Proposed Action – SLC 40	4-43
4.14.2	Alternative 1 – SLCs 36 A and 36 B	4-44
4.14.3	Alternative 2 – SLC 47	4-44
4.14.4	No-Action Alternative	4-44
5.0	APPLICABLE ENVIRONMENTAL REQUIREMENTS	5-1
5.1	Federal Regulations	5-1
6.0	PERSONS AND AGENCIES CONTACTED	6-1
7.0	LIST OF PREPARERS	7-1
8.0	REFERENCES AND DOCUMENTS CITED	8-1

LIST OF FIGURES

Figure 1-1	Florida Site Location Map
Figure 1-2	CCAFS Site Location Map
Figure 1-3	SLC 40 and SMARF Location Map
Figure 2-1	SLC 40 Launch Pad Location
Figure 2-2	Falcon 1 Launch Vehicle
Figure 2-3	Falcon 9 Launch Vehicle
Figure 2-4	Launch Azimuths
Figure 2-5	Dragon Capsule (Cargo Version)
Figure 2-6	Falcon 9 Launch-erector
Figure 2-7	SLC 40 (Proposed) New Falcon Site Layout
Figure 2-8	SMARF Vehicle Assembly Building
Figure 2-9	Simulated Dragon Capsule Landing
Figure 2-10	Conceptual Drawing of Proposed SLC 40 Assembly Building
Figure 2-11	Proposed SLC 40 Assembly Building Layout
Figure 2-12	Alternative Site SLC 36A Site Map
Figure 2-13	Alternative Site SLC 36B Site Map
Figure 2-14	CCAFS Zoning Plan
Figure 2-15	SLC 47 Site Location Map
Figure 2-16	Alcantara Launch Facility Location
Figure 2-17	Guiana Space Center Location
Figure 3.3-1	Wetlands and Floodplain Map – SLC 40
Figure 3.3-2	Wetlands and Floodplain Map – SLC 36A
Figure 3.3-3	Wetlands and Floodplain Map – SLC 36B
Figure 3.3-4	Wetlands and Floodplain Map – SLC 47
Figure 3.3-5	Wetlands and Floodplain Map - SMARF

LIST OF TABLES

Table 2.1	Launch Vehicle Parameter Comparison
Table 2.2	Summary of ES Subsystems and Envelope Payload Characteristics (EPC)
Table 3.2-1	A-Weighted Sound Levels of Common Sounds
Table 3.2-2	Measured Delta II Sound Levels, July 1992
Table 3.2-3	Falcon 9 Modeled Noise
Table 3.3-1	Threatened & Endangered Species Found in the Vicinity of CCAFS
Table 3.3-1	Threatened and Endangered Species
Table 3.5-1	Florida and National Ambient Air Quality Standards
Table 3.5-2	Summary of CCAFS Criteria Pollutant & HAPS Emissions for 2004 and 2005
Table 3.5-3	Ambient Air Concentrations for Criteria Pollutants near CCAFS and KSC (USAF, 2000a)
Table 3.10-1	Road Transportation Levels of Service
Table 3.10-2	Peak-Hour Traffic Volumes and LOS on Key Roads Serving CCAFS
Table 4.2-1	Comparison of the Falcon Vehicle Specifications with the Atlas II AS Vehicle Specifications
Table 4.2-2	Comparison of the Engine Noise Levels from the Falcon Vehicle and the Atlas II AS Vehicle (dB)
Table 4.2-3	Modeled Engine Noise for the Falcon 9 Launch Vehicle
Table 4.2-4	Comparison of Maximum Sonic Boom Overpressure Levels from the Falcon Vehicle and the Atlas II AS Vehicle
Table 4.2-5	Slow Response Sound Levels
Table 4.3-1	Threatened and Endangered Species Matrix
Table 4.5-1	Merlin Engine Exhaust Species
Table 4.5-2	Air Emissions (tons) per Launch of Candidates Vehicles in Lowest 3000 feet of Atmosphere
Table 4.5-4	Emissions from Wet Tests and Vehicle Launches (tons per year)
Table 4.7-1	Payload Processing Materials of a Routine Payload Spacecraft
Table 4.7-2	Hazardous Materials used per Titan IV and Atlas V Launches
Table 4.11-1	Pump Station #7 Capacity

LIST OF APPENDICES

Appendix A	45 SW and FAA Letter (emails) of concurrence
Appendix B	AE Form 813
Appendix C	Falcon 9 Debris Analysis
Appendix D	Air Data
Appendix E	Asbestos and Lead Based Paint Data
Appendix F	Falcon Noise Modeling
Appendix G	Sonic Boom Modeling
Appendix H	Payload Fuel Loads
Appendix I	Toxic Chemical Dispersion Model (Hypergolics)

ACRONYMS AND ABBREVIATIONS

AADT	Average Annual Daily Traffic
ACHP	Advisory Council on Historic Preservation
ACM	Asbestos Containing Material
AE	Adverse Effect
AF	Air Force
AFB	Air Force Base
AFI	Air Force Instruction
AFSPC	Air Force Space Command
AFMAN	Air Force Manual
AFTOX	Air Force Toxic Chemical Dispersion Model
AIRFA	American Indian Religious Freedom Act
Al ₂ O ₃	Aluminum Oxide
ALTRV	Altitude Reservation
AMU	Applied Meteorology Unit
ANSI	American National Standards Institute
ARPA	Archaeological Resources Protection Act
ASME	American Society of Mechanical Engineers
AST	Aboveground Storage Tanks
ASTG	Aerospace Test Group
avg	Average
AWSPL	A-Weighted (dBA) Sound Pressure Levels
BEBR	Bureau of Economic and Business Research
bls	below land surface
BMP	Best Management Practices
BSI	Boeing Services International • >C degrees Celsius
CAA	Clean Air Act
CCAFB	Cape Canaveral Air Force Base
CCAFS	Cape Canaveral Air Force Station
CCAS	Cape Canaveral Air Station
CCEMP	Consolidated Comprehensive Emergency Management Plan
CDNL	C-Weighted Day-Night Average Sound Level
CE	Commercially Exploited
CEM	Cape Environmental Management, Inc.
CEQ	Council of Environmental Quality
CERCLA	Comprehension Environmental Response Compensation and Liability Act
CERL	Construction Engineering Research Laboratories
CFR	Code of Federal Regulations
ch.	Chapter
CMD	Corrective Measures Design
CMI	Corrective Measures Implementation
CMS	Corrective Measures Studies
CO	Carbon Monoxide
constr.	Construction
COPC	Contaminants of Potential Concern
CRM	Cultural Resources Manager

ACRONYMS AND ABBREVIATIONS – Cont.

CRMP	Cultural Resources Management Plan
CS	Confirmation Sampling
CSEL	C-Weighted Sound Exposure Level
CSLA	Commercial Space Launch Act
CUP	Consumptive Use Permit
CWA	Clean Water Act
CZMA	Coastal Zone Management Act
CZMP	Coastal Zone Management Program
dB	Decibel
dBA	A-Weighted Decibel
DCE	Dichloroethene
DCG	Disaster Control Group
DERP	Defense Environmental Restoration Program
DNL	Day-Night Average Sound Level
DoD	Department of Defense
DOT	Department of Transportation
DPF	Defense Processing Facility
DSCS	Defense Secure Communication Satellite
EA	Environmental Assessment
EDC	Economic Development Commission of Florida's Space Coast
EELV	Evolved Expendable Launch Vehicle
EEZ	Exclusive Economic Zone
EFH	Essential Fish Habitat
EIAP	Environmental Impact Analysis Process
EIS	Environmental Impact Statement
EO	Executive Order
EPCs	Envelope Payload Characteristics
EPCRA	Emergency Planning and Community Right-to-Know Act
ER	Eastern Range
ERA	Ecological Risk Assessment
ERAP	Environmental Risk Assessment Program
ERP	Environmental Resource Permits
<i>ES</i>	<i>Envelope Spacecraft</i>
<i>ES</i>	<i>Engineering-Science, Inc.</i>
ESA	Endangered Species Act
ESB	Engineering Support Building
ESC	Environmental Support Contractor
ET	Earth Tech
EWR	Eastern and Western Range Safety Policies and Processes
FAA	Federal Aviation Administration
FAAQs	Florida Ambient Air Quality Standards
FAC	Florida Administrative Code
FCMA	Florida Coastal Management Act
FCMP	Florida Coastal Management Program
FDCA	Florida Department of Community Affairs

ACRONYMS AND ABBREVIATIONS – Cont.

FDEP	Florida Department of Environmental Protection
FDOT	Florida Department of Transportation
FEIS	Final Environmental Impact Statement
FETSA	Florida Endangered and Threatened Species Act
FFWCC	Florida Fish and Wildlife Conservation Commission
FMOs	Fishery Management Officials
FNAI	Florida Natural Areas Inventory
FONSI	Finding of No Significant Impact
FOT	Follow-On Test
FSTR	Full Spectrum Threat Response
ft	feet
ft ²	square feet
FWCC	Fish and Wildlife Conservation Commission
GDSS	General Dynamics Space Systems
GPS	Global Positioning System
HABS	Historic American Building Survey
HAER	Historic American Engineering Record
HAP	Hazardous Air Pollutants
HAPCs	Habitat Areas of particular Concern
HAZMAT	Hazardous Material
HCl	Hydrogen Chloride
HHRA	Human Health Risk Assessment
HMTA	Hazardous Materials Transportation Act
HQ AFSPC/SG	Headquarters Air Force Space Command Surgeon's Office
HVAC	Heating Ventilation and Air-Conditioning
ICBM	Intercontinental Ballistic Missile
IIP	Instantaneous surface Impact Point
IM	Interim Measure
IMS	Incident Management System
INF	Intermediate Nuclear Forces
INRMP	Integrated Natural Resources Management Plan
IPA	Isopropyl Alcohol
IRP	Installation Restoration Program
ISS	International Space Station
ITE	Institute of Transportation Engineers
JPC	Joint Propellants Contractor
KSC	Kennedy Space Center
kVA	Kilo-Volt Amperes
LBP	lead-based paint
LDCG	Launch Disaster Control Group
LEO	Low-Earth Orbit
Leq	Long Term Equivalent A-Weighted Sound Level
LOS	level of service
LOX	Liquid Oxygen
LT	Long Term

ACRONYMS AND ABBREVIATIONS – Cont.

LTM	Long Term Monitoring
LUCIP	Land Use Control Implementation Plan
LVC	Launch Vehicle Contractors
MACT	Maximum Available Control Technology
max	Maximum
MBTA	Migratory Bird Treaty Act
MCL	Maximum Contaminant Level
MEK	Methyl Ethyl Ketone
MGD	Million Gallons per Day
µg/m ³	Micrograms per Cubic Meter
MHz	Mega-Hertz
mm	Millimeters
MMH	Monomethylhydrazine
MMPA	Marine Mammal Protection Act
MNA	Monitored Natural Attenuation
MOA	Memorandum of Agreement
MPO	Metropolitan Planning Organization
MPPF	Multi-Payload Processing Facility
MR	Mitigation Required
MSFCMA	Magnusson-Steven Fishery Conservation and Management Act
MSL	Mean Sea Level
MST	Mobile Service Tower
MW	Mega-watt
MWH	Mega-watt Hours
N/A	Not Applicable
NAAQS	National Ambient Air Quality Standards
NAGPRA	Native American Graves Protection and Repatriation Act
NASA	National Aeronautic and Space Administration
NATO	North Atlantic Treaty Organization
NDE	Non-Destructive Engine
NE	No Effect
NEPA	National Environmental Policy Act
NESHAP	National Emission Standards for Hazardous Air Pollutant
NFRAP	No-Further Remedial Action Planned
NHPA	National Historic Preservation Act
NMFS	National Marine Fisheries Service
NO ₂	Nitrogen Dioxide
NOAA	National Oceanic and Atmospheric Administration
NOI	Notice of Intent
NO _x	Nitrogen Oxides
NPDES	National Pollutant Discharge Elimination System
NPL	National Priorities List
NRHP	National Register of Historic Places
NSA	New South Associates
NTO	Nitrogen tetroxide

ACRONYMS AND ABBREVIATIONS – Cont.

NWS	National Weather Service
NWSO	National Weather Service Office
O ₃	Ozone
OBG	O'Brien & Gere
OCST	Office of Commercial Space Transportation
ODS	Ozone Depleting Substances
OFW	Outstanding Florida Water
OPLAN	Operations Plan
OSHA	Occupational Safety and Health Act
OASPL	Overall Sound Pressure Level
OWS	Oil-Water Separator
PAE	Potentially Adverse Effect
PAFB	Patrick Air Force Base
PAH	Poly-nuclear aromatic hydrocarbons
Pb	lead
PCB	Poly-chlorinated biphenyl
PE	Positive Effect
PES	Parsons Engineering Science
PFDP	Preliminary Flight Data Package
PHSF	Payload Hazardous Servicing Facility
PHV	Peak-hour volume
PM ₁₀	Particulate matter equal to or less than 10 microns in diameter
PM _{2.5}	Particulate matter equal to or less than 2.5 microns in diameter
POL	Petroleum Products, Oils, Lubricants
PPF	Payload Processing Facility
ppm	parts per million
PPMP	Pollution Prevention Management Action Plan
PPPG	Pollution Prevention Program Guide
PPWG	Pollution Prevention Working Group
PSD	Prevention of Significant Deterioration
PTE	Potential to Emit
R&D	Research and Development
RCRA	Resource Conservation Recovery Act
REEDM	Rocket Exhaust Effluent Dispersion Model
RFI	RCRA Facility Investigation
RHU	Radioisotope Heater Units
RMP	Risk Management Plan
ROI	Regions of Influence
RP-1	Rocket Propellant 1 (standard kerosene rocket fuel MIL-P-25576)
RPM	Remedial Project Manager
RTG	Radioisotope Thermoelectric Generator
S/A	Similar in Appearance
SAEF-2	Spacecraft Assembly and Encapsulation Facility Number 2
SAFMC	South Atlantic Fishery Management Council
SAO	Senior Acquisition Officer

ACRONYMS & ABBREVIATIONS – Cont.

SAP	Satellite Accumulation Points
SARA	Superfund Amendments and Reauthorization Act
SCTL	Soil Cleanup Target Level
Secs.	Sections
SEL	Sound Exposure Level
SHPO	State Historic Preservation Officer
SIP	State Implementation Plan
SJRWMD	St. Johns River Water Management District
SLC	Space Launch Complex
SMAB	Solid Motor Assembly Building
SMARF	Solid Motor Assembly and Readiness Facility
SMG	Spaceflight Meteorology Group
SO ₂	Sulfur Dioxide
SPEGL	Short-Term Emergency Guidance Levels
SPIF	Spacecraft Processing and Integration Facility
SPL	Sound Pressure Level
SR	State Route
SRM	Solid Rocket Motor
SSC	Species of Special Concern
ST	Short Term
SW	Space Wing
SWI	Space Wing Instruction
SWMU	Solid Waste Management Unit
SWPPP	Storm Water Pollution Prevention Plan
T&E	Threatened and Endangered
TCE	Trichloroethylene
THC	Toxic Hazard Corridor
TNT	Trinitrotoluene
TPH	Total Petroleum Hydrocarbons
TPY	Tons per Year
TSCA	Toxic Substance Control Act
TSD	Treatment, Storage, or Disposal
TSDF	Treatment, Storage, or Disposal Facility
TSP	Total Suspended Particulate
U	Unknown Effect
UDMH	Unsymmetrical Dimethyl Hydrazine
UFC	Unified Facilities Criteria
U.S.	United States
US	U.S. Highway
USACE	U.S. Army Corps of Engineers
USAF	United States Air Force
U.S.C.	United States Code
USEPA	U.S. Environmental Protection Agency
USFWS	U.S. Fish and Wildlife Service
UT	Umbilical Tower
UV	Ultraviolet

ACRONYMS AND ABBREVIATIONS – Cont.

VAFB	Vandenberg Air Force Base
V/C	Volume-to-Capacity
VC	Vinyl Chloride
VOC	Volatile Organic Compounds
VPF	Vertical Processing Facility
WWTP	Wastewater Treatment Plant

1.0 PURPOSE AND NEED FOR THE PROPOSED ACTION

1.1 INTRODUCTION

This Environmental Assessment (EA) evaluates the potential environmental impacts associated with implementing the proposed launch operations for the Falcon 1 and Falcon 9 Launch Vehicles at Cape Canaveral Air Force Station (CCAFS), Florida. The Falcon Launch Vehicles are part of a commercial venture by Space Exploration Technologies, Inc. (SpaceX). The Air Force intends to lease the required land and facilities to SpaceX. Because SpaceX would use existing launch facilities at CCAFS for the Falcon Launch Vehicle Program, the Air Force is the lead agency in supervising preparation of the EA. The Federal Aviation Administration (FAA) Office of Commercial Space Transportation and National Aeronautics and Space Administration (NASA) are cooperating agencies in reviewing the preparation of the EA. SpaceX intends to apply for a launch license from the FAA to conduct launches of the Falcon 1 and Falcon 9 launch vehicles with commercial payloads from CCAFS. SpaceX also intends to apply for a re-entry license from the FAA for the re-entry of a space capsule and payload. NASA would be a potential customer for SpaceX launch services.

The Commercial Space Launch Act of 1984 (Public Law 98-575), as codified at 49 United States Code (U.S.C.) Subtitle IX, Ch. 701, Commercial Space Launch Activities, 49 U.S.C. Secs.70101-70119 (1994) (the Act) declares that the development of commercial launch vehicles and associated services is in the national economic interest of the United States. To ensure that launch services provided by private enterprises are consistent with national security and foreign policy interest of the United States and do not jeopardize public safety and safety of property, the Act authorizes the Department of Transportation to license and regulate United States commercial launch activities. Within the Department, the Secretary of Transportation's authority under Commercial Space Launch Activities has been delegated to the FAA's Office of Commercial Space Transportation. Therefore, at this time the FAA is a cooperating agency in reviewing the preparation of the EA.

In addition to the EA and determination, applicants for a launch license must complete a policy review and approval, safety review and approval, payload review and determination, and a financial responsibility determination. All of these reviews, including the EA, must be completed prior to receiving a launch or reentry license. All FAA safety analyses would be conducted separately and would be included in the terms and conditions of the license.

This EA has been prepared in accordance with the requirements of the National Environmental Policy Act (NEPA) of 1969, 42 U.S.C. Sec 4321 et seq., the Council on Environmental Quality (CEQ) regulations, 40 C.F.R. Secs 1500-1508 Environmental Impact Analysis Process (EIAP), as promulgated in Title 32 of the Code of Federal Regulations (CFR) Part 989, and Department of Defense (DoD) Directive 6050. Both NEPA and CEQ regulations require lead agencies to prepare or supervise the preparation of an EA for federal actions that do not qualify for a categorical exclusion and that may not require an Environmental Impact Statement (EIS). If this EA determines that the environmental effects of the proposed action are not significant, a Finding of No Significant Impact (FONSI) will be issued. Otherwise a notice of intent to prepare an EIS will be published.

1.2 LOCATION AND BACKGROUND

CCAFS occupies approximately 15,800 acres, (25-square-miles) of land on Florida's Canaveral Peninsula (Figure 1-1). The Canaveral Peninsula is on the east coast of Brevard County Florida, approximately 155 miles south of Jacksonville, 210 miles north of Miami, and 60 miles east of Orlando. It is 4.5 miles wide at its widest point (Figure 1-2). CCAFS has 81 miles of paved roads connecting various launch support

facilities with the centralized Industrial Area. The northern boundary of CCAFS adjoins the Kennedy Space Center (KSC) boundary on the barrier island. The Banana River separates CCAFS from KSC to the west. The Port of Cape Canaveral adjoins CCAFS to the south. CCAFS's eastern boundary is the Atlantic Ocean. The base is accessible primarily from U.S. Highway 528 which is to the south and from KSC which is to the west and north. A total of 33 Space Launch Complexes (SLC) have been constructed at CCAFS.

Along with the various launch and support facilities, CCAFS maintains a centralized industrial complex to support the technical, mechanical, and administrative needs of each launch program. The industrial complex contains structures that support the SLCs and includes warehouse and hanger space used to store critical spare parts and package payloads and serves as a base of operations for Civil Engineering, Base Operations, and command personnel.

The Air Force provides support to the United States government and commercial entities for low-cost and reliable access to space. A tremendous amount of research is being focused on reducing today's high cost of space access while increasing its reliability and safety.

Historically, CCAFS has been selected as the location for construction of facilities to launch several types of intermediate and long-range ballistic vehicles (e.g. Atlas, Delta, and Titan). Since the mid-1950s CCAFS has been the launch-head for the Eastern Range and launches have largely been associated with the launch of Air Force, government and civilian payloads. The 45th Space Wing (45 SW) is currently the host wing, under Space Command and conducts east coast military, civilian, and commercial launch operations. Operation and launch of the Falcon 1 and 9 Launch Vehicles would occur at the CCAFS launch facility designated as Space Launch Complex SLC 40 (Figure 1-3) which is located at the northern end of CCAFS, approximately 3,000 ft west of the Atlantic Ocean and 0.75 miles east of the Banana River. The SLC 40 was constructed in 1964 for the USAF Titan IIIC Missile Program.

SpaceX is a privately held company that has developed the Falcon 1 as a two-stage light-launch vehicle to put small spacecrafts into orbit with high reliability and at a relatively low cost. The Falcon 9 is a medium to heavy-lift vehicle. Both the Falcon 1 and the Falcon 9 vehicles have two-stages; the first stage is intended to be recovered and reused. The second stage of the Falcon 9 is also intended to be recovered. Both vehicles use only liquid fuels (See Section 2.1 below). The Falcon Launch Vehicle Program is designed to require minimal time for vehicle assembly and payload processing on the launch pad. SpaceX also intends to build a combined vehicle assembly and payload processing facility within the existing SLC 40 previously disturbed area and also plans to use the existing Solid Motor Assembly and Readiness Facility (SMARF) which had been used for the Titan program. The goal of the Falcon launch program is to launch a vehicle within a few days to several weeks of payload arrival on the launch site therefore requiring minimal time for payload processing and minimizing use of the launch pad. (AEROSTAR 2006)

1.3 PURPOSE AND NEED FOR ACTION

This document addresses the potential for impacts to the environment from the proposed launch of the Falcon 1 and Falcon 9 vehicles as part of SpaceX's Falcon Launch Vehicle Program at CCAFS. The potential impacts associated with the use of the launch vehicle and the facilities, and the re-entry / recovery of the Dragon capsule are addressed in this EA and have been assessed using the most current information available. SpaceX plans to use SLC 40 as its launch site with the SMARF, associated roadways and support facilities and will complete all necessary construction, retrofitting and refurbishment to meet its own specifications, while complying with all range and base requirements. The goal is to launch up to six (6) Falcon 1 vehicles and up to six (6) Falcon 9 vehicles per year starting in

2008. The program is expected extend five years, after which time the Air Force may extend the real property lease for continued use by SpaceX.

The United States has recognized that space transportation costs must be significantly reduced in order to make continued exploration, development, and use of space more affordable. The Space Transportation section of the National Space Transportation Policy of 1994 addresses the commercial launch sector, stating that “assuring reliable and affordable access to space through U.S. space transportation capabilities is fundamental to achieving National Space Policy goals.” The National Space Policy provides these guidelines (in part):

- Balance efforts to modernize existing space transportation capabilities and invest in development of improved future capabilities.
- Maintain a strong transportation capability and technology base.
- Reduce the cost of current space transportation systems while improving reliability, operability, responsiveness, and safety.
- Encourage, to the fullest extent feasible, the cost-effective use of commercially provided United States products and services.

The Proposed Action and similar endeavors are needed to fulfill the goal of the National Space Transportation Policy to achieve affordable access to space. This goal may be met without compromising public safety, unduly interfering with commercial and private aircraft, or substantially adversely affecting the environment. SpaceX, solely using private funding, has built a launch vehicle, and cargo capsule intended to substantially reduce the cost of reliable U.S. enterprise access to space. The need for this action and corresponding goals have been established in part because SpaceX has been selected by NASA to demonstrate delivery and return of cargo to the International Space Station (ISS). The CCAFS location and SLC 40 in particular has been selected as the preferred alternative because it supports launches to inclinations supporting the ISS, and because of its current availability and history of substantial previous uses as a launch site and support facility. The Commercial Space Launch Act also allows government infrastructure and resources currently underutilized to be used as excess capacity to promote commercial investment and use of space.

1.4 SCOPE OF THE ENVIRONMENTAL ASSESSMENT

1.4.1 Future Use of This Document

Future projects planned by SpaceX associated with operations at CCAFS would be reviewed and evaluated to determine if they fall within the scope of this EA. New space vehicles or re-entry/recovery operations planned to be used by SpaceX at CCAFS would also require review of this EA and/or the generation of a new EA. In some cases, a supplement to this EA may be required. If a Supplemental EA is required, a new Finding of No Significant Impact (FONSI) or, conceivably, an EIS would be necessary prior to committing Federal resources. Future actions that are found to result in significant impact to the environment that could not be mitigated to a level of insignificance would need to be addressed in an Environmental Impact Statement.

The FAA will also rely on this analysis to support its environmental determination for a launch license for SpaceX for the Falcon 1 and Falcon 9 Launch Vehicle Program at CCAFS and re-entry / recovery license for the Dragon Capsule. At the conclusion of this environmental review process, the FAA will issue a separate environmental decision to support its licensing determinations. The FAA and NASA will individually draw their own conclusions from the analysis presented in this EA and assume responsibility for its environmental decision and any related mitigation measures. In order for the FAA to use this

analysis to support its determination, the EA must meet the requirements of FAA Order 1050.1 E, *Policies and Procedures for Considering Environmental Impacts Change 1* (March 2006), which describes the Agency's procedures for implementing NEPA.

1.4.2 Structure of This EA

This EA presents the analysis and description of potential environmental impacts that could result from the Proposed Action and Alternatives. As appropriate, the affected environment and environmental consequences of the Proposed Action and Alternatives are presented by site-specific descriptions.

Section 20 of this EA describes the Proposed Actions and location of those actions, two alternative locations considered, and the No Action Alternative. Three other alternatives are briefly discussed but eliminated from further consideration. Section 3.0 provides regional and site-specific information related to land use/visual resources, noise, biological resources, cultural resources, air quality, orbital debris, hazardous materials/hazardous waste, water resources, geology and soils, transportation, utilities, health and safety, socioeconomics, and environmental justice. The regional information included in this section provides the background for understanding the context of the site-specific information that could affect or be affected by the Proposed Action and Alternatives. Section 4.0 addresses the potential effects of the Proposed Action and Alternatives on the resource areas analyzed and addresses potential cumulative impacts. As appropriate, the effects are presented in terms of whether they are operation or construction related. Any required mitigation efforts are also discussed here. Section 5.0 presents a list of some but not all applicable environmental requirements relating to the Proposed Action or Alternatives.

A letter of cooperation between the FAA and the Air Force in the preparation of this EA is provided in Appendix A. The Air Force Form 813 is also included in Appendix B.

1.5 REGULATORY REQUIREMENTS AND COORDINATION

The Florida State Clearinghouse reviews EAs for projects planned at CCAFS pursuant to Gubernatorial Executive Order 95-359; the Coastal Zone Management Act; 16 U.S.C. SS 1451-1464 as amended; and the National Environment Policy Act, 42 U.S.C. SS 4321, 4331-4335, and 4341-4347. The State of Florida Clearinghouse sends copies of the draft EAs to applicable regulatory agencies for review and submits any comments so that they may be addressed in the final EA. Additionally, the following regulatory coordination, approval, and permits other than with the Air Force and FAA, would be required for the proposed project:

- Coordinate with the Florida Department of Community Affairs (FDCA) in accordance with the Coastal Zone Management Act (CZMA) to ensure coastal zone management program consistency.
- Coordinate with the U.S. Fish and Wildlife Service for consultation pursuant to the federal Endangered Species Act (ESA), and the Migratory Bird Treaty Act (MBTA).
- Submit a Notice of Intent (NOI) and prepare a Storm Water Pollution Prevention Plan (SWPPP) for a General National Pollutant Discharge Elimination System (NPDES) Permit for Storm Water Discharges Associated with Construction Activities from the St Johns River Water Management District if construction activity may involve the disturbance of more than one acre.
- Prepare a Spill Prevention, Control, and Countermeasures (SPCC) Plan pursuant to state and federal regulations for the aboveground storage tanks (ASTs) for LOX, RP-1, liquid nitrogen, and gaseous helium.
- Register the AST for RP-1 with the Florida Department of Environmental Protection (FDEP) in accordance with FAC 62-762.

- Obtain an Authority to Construct and Permit to Operate from the Brevard County Air Pollution Control District for all applicable stationary and portable source equipment, painting activities, and solvent wipe and flush operations.
- Obtain a unique U.S. Environmental Protection Agency (EPA) identification number for the generation of hazardous waste.
- Obtain permits from FDEP for Water Main extensions, Wastewater Collection/Transmission System and Industrial Wastewater for deluge water disposal activities. Also obtain NPDES Multi-sector General Permit.
- Obtain an Environmental Resource Permit (ERP) from the SJRWMD for stormwater management at SLC 40.

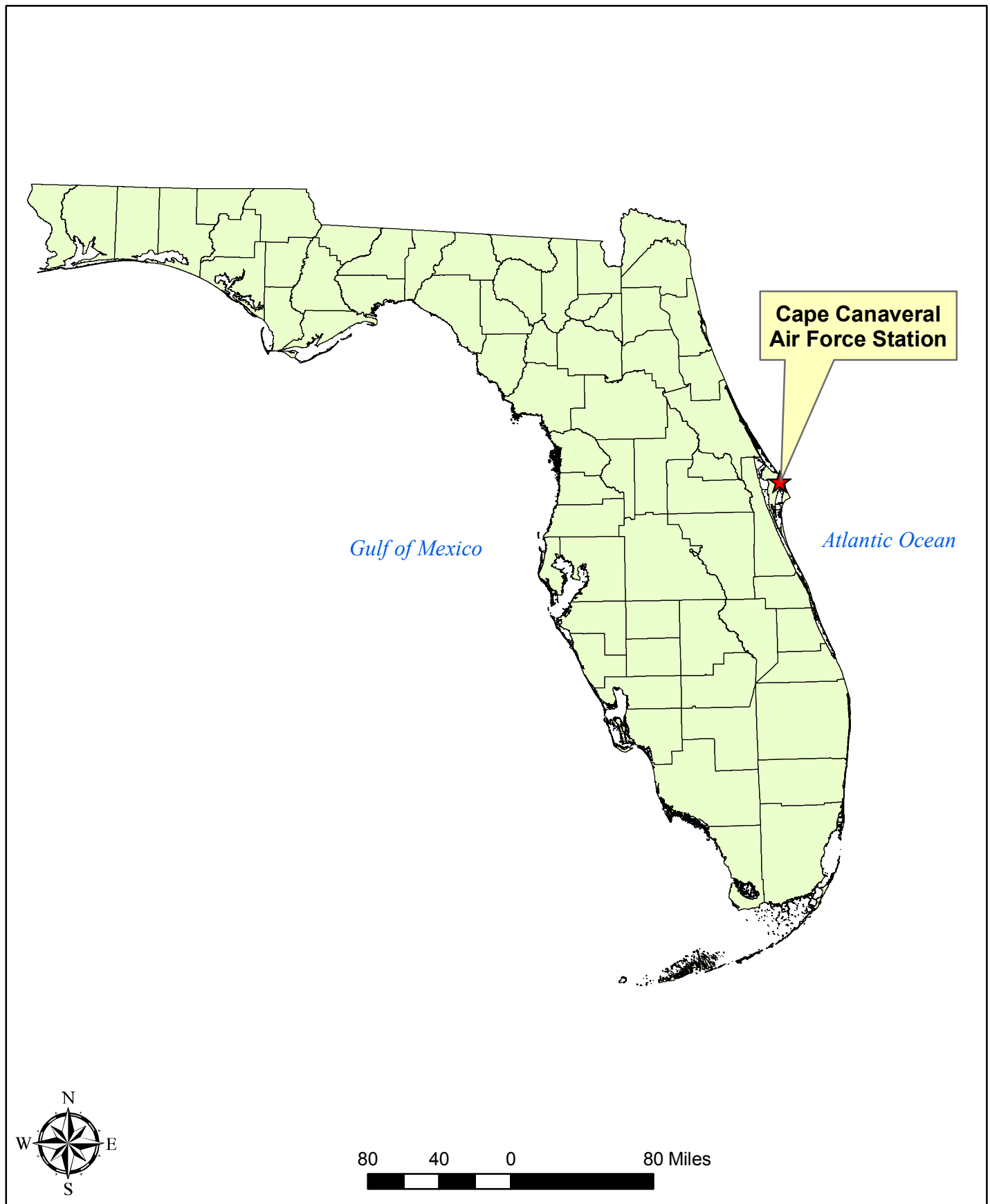

FIG 1-1 FLORIDA SITE LOCATION MAP



**Environmental Assessment
Space X Falcon 1 and Falcon 9
Launch Program
Cape Canaveral Air Force Station
Brevard County, Florida**

DRAWN BY: JPK

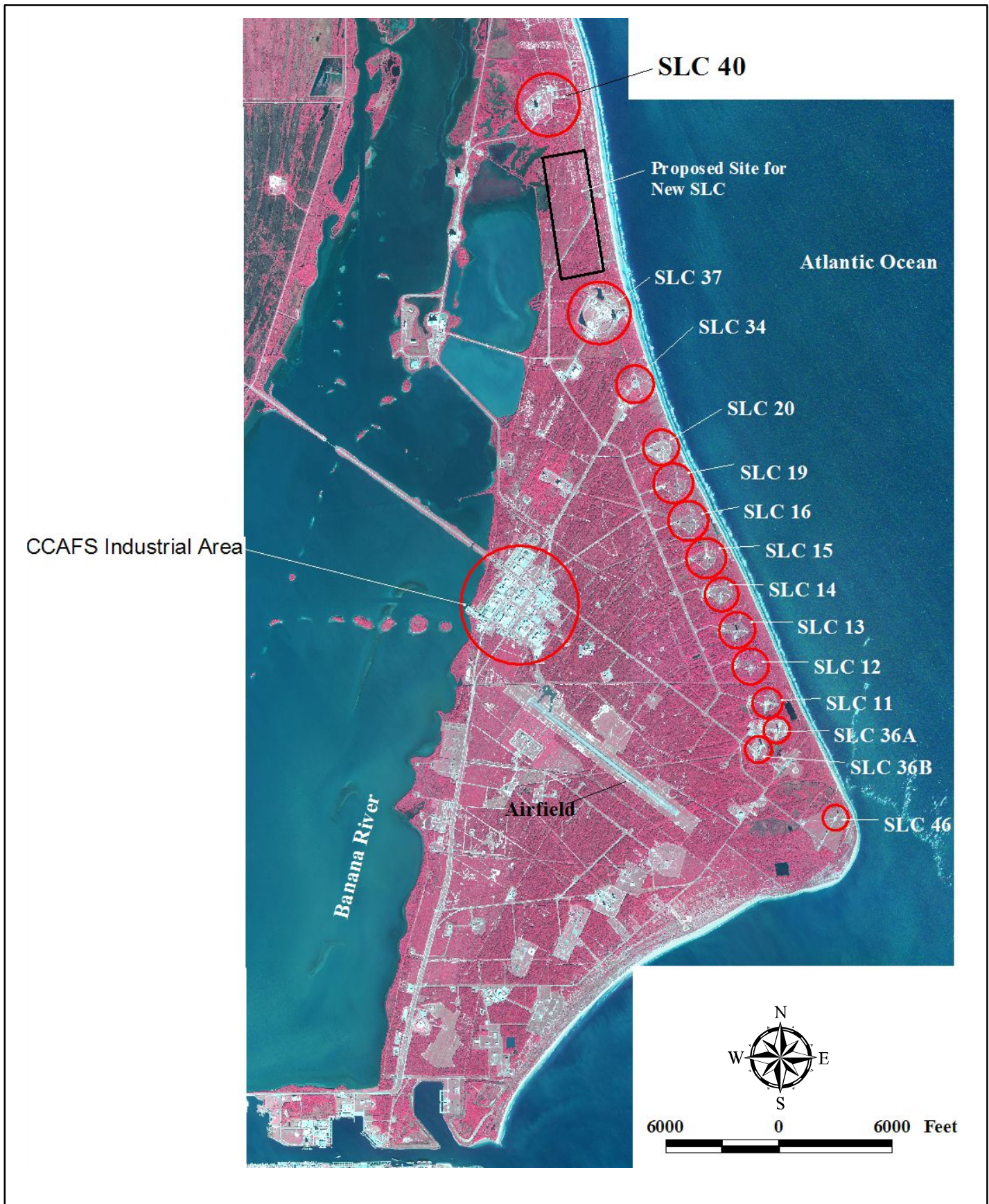

FIGURE 1-2 CCAFS SITE LOCATION MAP

	Environmental Assessment Space X Falcon 1 and Falcon 9 Launch Program Cape Canaveral Air Force Station Brevard County, Florida	DRAWN BY: JPK



FIGURE 1-3 SLC 40 and SMARTF LOCATION MAP



Environmental Assessment
Space X Falcon 1 and Falcon 9
Launch Program
Cape Canaveral Air Force Station
Brevard County, Florida

DRAWN BY: JPK

2.0 DESCRIPTION OF THE PROPOSED ACTION AND ALTERNATIVES

2.1 DESCRIPTION OF PROPOSED ACTION

SpaceX proposes to operate its Falcon 1 and Falcon 9 Launch Vehicles to provide commercial space operations from CCAFS SLC 40. The Proposed Action includes launching two new space launch vehicles, the Falcon 1 and the Falcon 9 while utilizing the SMARF building as a vehicle support facility and the re-entry and recovery of the Dragon Capsule. The goal is to conduct 8 to 12 launches per year for both the Falcon 1 and Falcon 9; beginning with up to six launches for each vehicle in 2008. All flights are expected to have payloads which would include satellites, ISS cargo, or experimental payloads. In addition to standard payloads, the Falcon 9 vehicle may also carry a capsule as a payload that is being developed to deliver cargo to the International Space Station under contract with NASA.

SLC 40 has been used since the early 1960s to operate the Titan missile program. SLC 40 was owned by the USAF and operated by a variety of government contractors including Boeing, Martin Marietta and Pan Am/Johnson Controls (USAF 2002e). SLC 40 is not considered a historic complex and there are no historic properties located in the immediate vicinity (45SW 1999). Refurbishment to upgrade SLC 40 from a Titan 34D configuration to a Titan IV configuration began in July of 1990 (ES 1992). The launch complex continued to actively support the Titan Program until the discontinuation of Titan launch operations in 2005 after the final Titan IV launch which took place on April 29, 2005. Various launch support buildings located at the site include a ready building, complex support building, protective clothing building, and refrigeration building (Figure 2-1). The complex also contains two security buildings, and is a restricted access area that is only accessible by authorized personnel (USAF 2002e). The complex is an Installation Restoration Program (IRP) site and has recently undergone clean-up activities for poly-chlorinated biphenyl (PCB) contaminated soil which ended in April 2007 (Corrective Measure Implementation Report April 2007).

The SMARF and associated warehouse (Facility 69800 and 69805 respectively) are located approximately a mile south-southwest of SLC 40 and is connected by road and railroad tracks. They were constructed in 1991 and 1997 respectively to support Titan III, 34D, and IV program launches. The SMARF is a large 58,793-ft² facility formerly used to assemble solid rocket motors to the core vehicle for the Titan IV program. The facility has a concrete foundation and floor with metal walls and roof. It is 250 ft high and contains a 500-ton and 220-ton overhead cranes, two stacking cells, two end cells, an ultrasonic inspection room, tool cribs and other associated rooms. The building is currently being kept in a minimum operations and maintenance condition. The warehouse is a 5,500-ft² building with a concrete floor, metal walls and roof. It was used to store support and handling equipment and limited flight ground support hardware associated with the Titan IV program. It is currently empty.

The Falcon 1 vehicle is a two-stage, light-lift launch vehicle designed to put small spacecraft into orbit with high reliability and low cost. The first stage, with a single Merlin rocket engine, will be recoverable and the second stage will not be recoverable. The Falcon vehicles use the liquid propellants liquid oxygen (LOX) and RP-1, a type of kerosene commonly used as a rocket propellant (may be cited as kerosene in this document). No solid fuels or propellants are used. Some payloads are expected to be loaded with small amounts of liquid or solid propellants for use in orbit after the launch flight (See Section 2.1.1.4 Payloads below). Payloads are not expected to have substantial amounts of radioactive materials on board. In most instances there will be no

such materials on board, with micro-curie amounts (e.g., instrument calibration sources and detectors) for the remainder.

The Falcon 9 is also a two stage, liquid launch vehicle in the medium-lift launch class that will also be used to place space systems and satellites into orbit. The basic design of the Falcon 1 and Falcon 9 rockets are the same. Heavier lift capability is achieved in the Falcon 9 by increasing the vehicle length and diameter and using 9 Merlin engines on the first stage, as opposed to a single Merlin engine for the Falcon 1. The second stage and payloads on the Falcon 9 may contain small quantities of LOX or kerosene or other propellants including Nitrogen tetroxide (NTO), Monomethylhydrazine (MMH), other hydrazine propellants, and solid propellants. The first and second stages of the Falcon 9 will be recovered and may be reused.

The Falcon Launch Vehicle Program is designed for minimal vehicle assembly or processing on the launch pad, with most of the vehicle checkout and preparation occurring at the existing SMARF building just south of SLC 40 or at a proposed new construction facility on SLC 40 grounds (cited as the Vehicle Checkout Hangar, or just the Hangar, in this EA). Payloads will be processed at either the SMARF, SLC-40 Hangar facility or an existing Payload Processing Facility. Both vehicles would be fueled on the pad on the day of the launch. The goal is to launch within a few days to several weeks of payload arrival at the launch site.

SLC-40 has been deactivated and placed in a “pre-demolition” state by the 45th Space Wing (45 SW) as a result of the decision to implement the Evolved Expendable Launch Vehicle Program at Vandenberg Air Force Base and at CCAFS (Environmental Assessment for the Deactivation and Turnover of Titan Space Launch Vehicle Capability September 2005). Therefore, SpaceX would need to conduct limited refurbishment of the existing support buildings to bring Launch Complex 40 back into operation as a launch facility for the Falcon Launch Vehicle Program. This EA assumes Falcon 1 and Falcon 9 launch operations can be executed without the demolition of facilities such as the Umbilical Tower (UT). However, since both rockets can be launched without use of those structures, demolition conducted under other 45 SW general plans is not precluded.

Refurbishment of SLC 40, the SMARF, and operation of the Falcon Launch Vehicle Program would comply with all FAA, and other federal, state, and local, regulations and requirements, and Air Force requirements contained in the AFSPC 91-710, Range Safety Requirements, Chapter 5, Facilities and Structures Documentation, Design, Construction, Test and Inspection Requirements, as tailored for the Falcon program, and any 45 SW specific guidance documents.

Further details on the operation and construction phases of the proposed Falcon Launch Vehicle Program are provided in Sections 2.1.1 and 2.1.2, respectively.

2.1.1 Operation Phase

2.1.1.1 Launch Vehicles

Falcon 1 Launch Vehicle

The Falcon 1 (Figure 2-2) is a small, unmanned, light-lift, two-stage, liquid fueled vehicle with a gross lift-off weight of approximately 27,273 kg (60,000 pounds) that can carry payloads between 275 and 1000 pounds depending on the orbit. At 70 feet in length with a diameter of 66 inches, tapering to 60 inches on the second stage, the Falcon 1 is much smaller than many other space

launch vehicles launched from CCAFS, such as the Titan IV which launched from SLC- 40. See Table 2.1-1 for comparison.

Both the first and second stages use only liquid propellants (LOX and RP-1). The first stage uses a turbo pump to feed the propellant, while the second stage is pressure-fed using gaseous helium stored in high pressure, composite over wrapped cylinders to pressurize the propellant tanks. Quantities of helium required for Falcon 1 processing are 16.5 kilograms (36.9 pounds) for first stage pressurization, engine spin start, and purging and 9.8 kilograms (21.7 pounds) for second stage pressurization. The helium flow is controlled through solenoid valves. Propellant use (in gallons) and specifications for each stage are as follows.

First and Second Stages

The first stage consists of aluminum LOX and RP-1 tanks with a common bulkhead powered by a 90,000 pound thrust Merlin LOX/RP-1 engine with Pintle Injector, a pump-fed gas generator cycle, turbine exhaust roll control, and hydraulic thrust vector control. The propellant tanks hold 3,357 gallons (34,362 pounds) of LOX and 2,178 gallons (15,782 pounds) of RP-1. The second stage consists of aluminum-lithium LOX and RP-1 tanks with a common bulkhead, and uses helium as a pressurant. The engine is a 7,500-pound thrust Kestrel engine with Pintle injector, hot helium attitude control, and an electromagnetic actuator for thrust vector control. The propellant tanks hold 582 gallons (5,941 pounds) of LOX and 350 gallons (2,517 pounds) of RP-1.

Flight Thrust Termination System

In the event the Falcon 1 launch vehicle varies from its planned trajectory, the launch vehicle will be equipped with a destructive flight termination system. The thrust termination system is activated by a command from the Range Safety Officer and disables power to the vehicle engines. Once power is removed, there are up to six different valves that close and immediately shut off the first stage engine. Four valves close on the second stage, again shutting down the stage's engine. Thus, upon activation of the thrust termination system the Falcon 1 launch vehicle would fall to the ocean intact and may explode upon impact, depending on the circumstances and time in the flight of the termination. The destructive termination system includes two linear shaped charges that are intended to rupture the vehicle tanks when commanded to destruct, thus dispersing propellants and breaking up the vehicle to minimize the impact to ground assets.

Falcon 9 Launch Vehicle

The Falcon 9 (Figure 2-3) is a medium class launch vehicle with a gross lift-off weight of approximately 315,000 kilograms (693,000 pounds) and an overall length of 178 feet. The Falcon 9 uses LOX and RP-1 to carry payloads into orbit and is basically a scaled up version of the Falcon 1 vehicle.

First and Second Stages

The first stage of the Falcon 9 is approximately 12 ft by 100 ft, and includes 9 Merlin engines, the same engine used on the first stage of the Falcon 1. The second stage is approximately 12 ft by 41 ft, not including the fairing and payload, and uses 1 or 2 Merlin engines. The fairing will be 17 ft by 50 ft, and there may also be a smaller version used. The first stage consists of LOX and kerosene tanks that hold 146,000 liters (38,672 gallons) of LOX and 94,000 liters (24,840 gallons) of kerosene. The second stage consists of 27,600 liters (7300 gallons) of LOX and 17,400 liters (4600 gallons) of kerosene in tanks with a common bulkhead. Like the Falcon 1, the

Falcon 9 launch vehicle uses helium gas stored in high pressure, composite over wrapped cylinders to pressurize the propellant tanks. Quantities of helium required for Falcon 9 processing are 59 kilograms (130 pounds) for first stage pressurization, engine spin start, and purging and 24.6 kilograms (54 pounds) for second stage pressurization. The helium flow is controlled through solenoid valves.

Flight Termination System

The Falcon 9 launch vehicle will be equipped with a destructive termination system similar to that of the Falcon 1 vehicle. This system will terminate the flight by opening the vehicle tanks to disperse propellants. In this event, the debris will impact in a wider area but in smaller pieces. A purely thrust termination capability is also present. The termination method selected by Range Safety will be based on the required trajectory and the payload.

**Table 2.1-1
Launch Vehicle Parameter Comparison**

Launch Vehicle	Falcon 1	Falcon 9	AtlasIIAS	Delta IV	Titan IV
Length	68ft (20.7m)	178ft 54.3m)	156ft(47.54m)	230ft(70m)	183ft(55.8m)
Width	5.5ft (1.7m)	12ft (3.6m)	10ft(3.04m)	16.4(5m)	14ft (4.3m)
Stages	2	2	2	2	2 + 2SRM*
First Stage Propellant	LOX /RP-1	LOX / RP-1	LOX / RP-1	LOX /LH2	Liquid and solid*
Weight	60,000Lbs 27,273 kg	693,000Lbs 315,000 kg	413,500Lbs 187,954Kg	1.63MLbs 737,994Kg	2.07MLbs 940,909Kg
Thrust at Lift-off	454KN 102 KLbf	4,4000KN 1.01MLbf	3546KN 797 KLbf	650 KLbf	>2.5MLbs

*Note: Titan IV first stage contains a core rocket engine using Hypergolic propellants and two SRMs using 88% Hydroxyl Terminated Polybutadiene fuels

2.1.1.2 Launch Trajectory

Falcon launch vehicle trajectories would be specific to each particular mission. Example trajectories from this site would be primarily 90 degrees for geo-transfer orbits and 42.25 degrees for support of the ISS. See Figure 2-4 for an available launch azimuths (trajectory) window which may be used.

2.1.1.3 Frequency of Launches

Up to six (6) launches of the Falcon 1 would be conducted per year beginning in 2008, and up to six (6) launches also for Falcon 9 per year beginning in 2008. The expected duration of the program is 5 years, with possible extensions after program evaluation by the Air Force. As the program matures, there could be a potential of launching eight (8) to twelve (12) per year. No test flights are currently planned and all flights are expected to have payloads. According to FAA forecasts, world wide average annual commercial space launches are expected to exceed 23.6

between now and 2010 with an expected demand of 34 in 2007. For comparison, the Titan program (Titan III through Titan IV vehicles) successfully executed 55 launches from SLC 40 and 27 launches from SLC 41 between 1965 and 2005.

2.1.1.4 Payloads

The Falcon 1 may carry small payloads, up to approximately 1000 lbs, consisting mostly of non-hazardous materials. Some payloads may use small amounts of propellants for on-orbit maneuvering.

Falcon 9 payloads including the Dragon capsule, weighing up to 12,000 lbs, (5,443 kg) will almost always include some additional propellants on board, either for orbit maintenance or orbital insertion burns. These propellants, for payloads of both vehicles, may include hypergolic fuels such as Unsymmetrical Dimethyl Hydrazine (UDMH), MMH and NTO, and pressurized gasses including helium and nitrogen, and some solid propellants. Quantities will vary but could be up to a total of 4885 lbs (1,225 kg) for combined weight of the two components. In addition, a small amount of ordnance, such as small explosive bolts and on-board batteries are typical. Propellants will be stored prior to use in a certified facility near the facility where the loading will occur. Residual propellants will be returned to the storage facilities. All hazardous materials will be handled in accordance with Federal and 45SW guidance. Payload plans are not expected to include substantial amounts of radioactive materials. In most instances there will be no such materials on board, with micro-curie amounts (e.g., instrument calibration sources and detectors) for the remainder. Parameters for “spacecraft” containing payloads, including the Dragon capsule, (Figure 2-5) fit within the parameters previously analyzed in the NASA Routine Payload Final Environmental Assessment published in June of 2002 and briefly discussed below.

The Routine Payload EA discusses the concept of an Envelope Spacecraft (ES) which came from the need to provide a benchmark describing a bounding case for quantities and types of materials, emissions, and instrumentation. In addition, insofar as the pre-launch activities that are required to prepare routine payload spacecraft for launch are routine and not unusual, those activities were implicitly bounded by that ES as well. Within this context, the ES should be considered a hypothetical spacecraft whose components, materials and associated quantities, and flight systems represented a comprehensive bounding reference design for routine payload spacecraft. Any proposed spacecraft that presented lesser or equal values of environmentally hazardous materials or sources in comparison to the ES may be considered a NASA routine payload spacecraft within the purview of that Environmental Assessment. (NASA 2002)

The quantitative levels noted for the ES Envelope Payload Characteristics (EPCs) were derived from a review of over 20 proposed NASA and USAF payloads tentatively scheduled for launch during the 2002-2012 period using expendable launch vehicles. Of the proposed payloads, those incorporating characteristics with unusual or high potential for substantial environmental impact were excluded and include the use of radioisotope thermoelectric generators (RTGs) and radioisotope heater units (RHUs) as well as the equipment and operations associated with extraterrestrial sample return. Of the remaining proposed payloads, spacecraft systems with minor potential for environmental impact were identified and evaluated for:

- Solid, liquid, and electric (ion) propellant types and quantities
- Laser power levels and operating characteristics
- Explosive hazard potentials

- Battery electrolyte types and quantities
- Hazardous structural materials quantities
- Radio frequency transmitter power
- Radioisotope instrument components (e.g. calibration sources)

A theoretical “envelope” payload was defined by the magnitudes of all of these characteristics equal to the maximum found in all the reviewed payloads, increased by 25% to reasonably allow for future growth potential. The ES spacecraft (in this case the Dragon Capsule) would be launched into Earth’s orbit or toward another body in the Solar System (in this case the ISS). Table 21-2 presents the maximum quantities of materials that would be carried by the ES spacecraft. Minor materials that are not listed may be included on the ES spacecraft as long as they pose no substantial hazard (NASA Routine Payload EA June 2002). The Dragon’s planned payload fits within these parameters. The Dragon capsule, is 12 to 17 feet tall and similar in design to the Apollo command capsule. Prior to launch, the Dragon will be processed similarly to any other payload.

**Table 2.1-2
Summary of ES Subsystems and Envelope Payload Characteristics (EPC)**

Structure	Unlimited: aluminum, magnesium, carbon resin composites, and titanium Limited: beryllium [50 kg (110 lb)]
Propulsion	Mono- and bipropellant fuel; 1000 kg (2200 lb) (hydrazine); 1000 kg (2200 lb) (monomethylhydrazine) Bipropellant oxidizer; 1200 kg (2640 lb) (nitrogen tetroxide) Ion-electric fuel; 500 kg (1100 lb) (Xenon) SRM; 600 kg (1320 lb) (AP)-based solid propellant
Communications	Various 10-100 W (radio frequency) transmitters
Power	Solar cells; 150 A-Hr (Ni-H2) battery; 300 A-Hr (LiSOC) battery; 150 A-Hr (NiCd) battery
Science instruments	10 kW radar ANSI safe lasers (NASA Routine Payload EA June 2002)
Other	Class C EEDs for mechanical systems deployment Radioisotopes limited to quantities that are approved for launch by NASA Nuclear Flight Safety Assurance Manager Propulsion system exhaust and inert gas venting

2.1.1.5 Launch Site Operations

Payload preparation activities would be conducted in parallel with most launch vehicle preparation activities. Payload activities include payload checkout, spacecraft propellant loading, and payload encapsulation in the fairing. These actions are expected to occur at the SMARF and associated warehouse or the SLC-40 Hangar facilities. Hazardous materials used with payloads will be handled per CCAFS environmental standards and safety standards. An emergency response team will be established and spills will be contained and cleaned up per the procedures

identified in the CCAFS Environmental Emergency Plan. Spills of hazardous materials are covered under the 45 SW Full Spectrum Threat Response (FSTR) Plan 10-2, Volume II, Hazardous Material (HAZMAT) Emergency Planning and Response, applicable to CCAFS.

Falcon 9 pre-launch activities are very similar to those of Falcon 1. The Falcon 1 or 9 stages would arrive separately, from El Segundo, CA, via aircraft at the Skid Strip, truck, or rail and will be placed in the Falcon 9 processing hangar (the SMARF or on-site SLC 40 hangar facility). There, the stages will be checked and prepared for mating. When ready, the payload will be encapsulated in a horizontal orientation, and then mated to the launch vehicle. Figure 2-6 shows the Falcon 9 vehicle and the launcher-erector. Approximately 6 days prior to launch, the Falcon 1 or 9 will be moved to SLC-40 and connected to the stand. If origination is from the SMARF, the existing rail road tracks may be used; the vehicle pulling the launch vehicle and stand would be a wheeled vehicle, not a train locomotive. The vehicle will then undergo an additional series of tests while horizontal or vertical at the pad. Both vehicles may be erected and de-erected several times prior to launch – the transporter/erector is designed to make this operation quick and simple. The day of launch, the vehicle will be erected and final checks completed. Approximately 25 people would be involved in both Falcon 9 and Falcon 1 launch preparation activities.

For the near term, LOX for both vehicles will most likely be trucked in and stored on CCAFS. Helium will be used by the Falcon 1 and Falcon 9 vehicle systems as a pressurant for the main tanks during flight. Helium will also be used as a purge during fueling operations and at engine start. The helium will be stored in standard, ASME certified storage tanks. RP-1 for both vehicles will be stored in containers located in containment systems at SLC 40 near facilities which formerly were for hydrogen storage. All tanks and containment systems will be cleaned, tested and recertified before use; RP-1 tanks will be tested to ASME Section VIII Pressure Vessel Code requirements or API storage tank requirements as applicable. Permanent over-ground lines will be installed to connect both the LOX area and the RP-1 storage area to the launch pad. These piping systems will be designed, installed and tested in accordance with ASME B31.3 Piping Code requirements.

After final systems checkout, there will typically be a mission rehearsal without propellants on board (dry) plus a mission rehearsal with propellants located on the vehicle (wet) to verify full launch readiness. Two dress rehearsals are typical in the launch preparation schedule to allow for team training and coordination of activities between the SpaceX crew and CCAFS. As required, wet dress rehearsals, which include fully fueling the launch vehicle, may be conducted. Under some circumstances, static fire tests of both vehicles may be conducted at the launch site, where the vehicle is fully fueled and the engine ignited and run for up to 5 seconds as a thorough test of all systems.

First and second stage fueling of RP1 and LOX would be done with standard zero-leak quick disconnect fittings typically used in the aircraft industry. Gaseous nitrogen would be used on the system for cleanliness purges and liquid nitrogen would be used for cooling purges on an as-needed basis. Gaseous nitrogen would be drawn from the CCAFS range supply system or generated directly from liquid nitrogen. In addition, 25 gallons of isopropyl alcohol would be on-site per launch for additional cleaning operations; though only 5 gallons are estimated to be required for various cleaning operations during the launch preparation. No solvent flushes would be performed during operation of the Falcon Launch Vehicle Program.

On a per-mission basis, launch campaigns (preparation for and launch) are expected to last from two to eight weeks. During a launch campaign, an average of 10 to 12 SpaceX employees – with a peak of 25 personnel for about one week – would be present at SLC-40, not including payload support personnel. Ground transportation support during a launch campaign would be minimal, consisting of a truck to deliver the crane and three delivery trucks for the first stage, second stage and payload. Between launch campaigns, 3-10 employees would be present at the site. Personal vehicles would be used to commute on- and off-site.

2.1.1.6 Primary Support for Launch Vehicles and Payloads

SpaceX has plans for four separate options or actions to support launch vehicle assembly and payload preparation for its Falcon 1 and Falcon 9 launch program. The first option proposes to lease facilities from a commercial company (Astrotech) in the Titusville area which would serve as the initial primary payload assembly facility for the Falcon launch program. Payloads would then be trucked to SLC 40 prior to launch. All DOT requirements for transport would be adhered to.

The second support option would be constructing a new vehicle assembly facility and payload processing facility, (the Hangar), either in the northeast quadrant of, and within the existing security perimeter area at SLC 40 or in the south end of the existing SLC 40 perimeter (Figure 2-7) (See Section 2.1.2 below). The security fencing may be modified slightly to enclose the building. This area would be used for all unloading, storage, and any final payload processing that would take place at this facility. The site plan would be reviewed by the 45SW Range Safety office to ensure proper placement of storage and processing areas. Approved safety procedures for hazardous payloads will be in place at Launch Complex 40 (see Safety Systems). Existing payload processing facilities at CCAFS area include the following, and all instructions which guide operations at these facilities would be implemented at the new SpaceX facility (AEROSTAR 2006).

The third option for payload support may include the temporary use of a number of available government facilities suitable for payload operations. All operations within these facilities would be consistent with the original design and intended use of the facilities. These include the following.

Vertical Processing Facility (VPF) – The VPF is used to integrate vertically processed payloads. It is located in the Hypergol/Payload Test Area in the KSC Industrial Area. The high bay contains two payload workstands. The VPF is capable of conducting hazardous processing using monopropellants.

Multi-Payload Processing Facility (MPPF) – The MPPF is located in the KSC Industrial area. It is designed for non-hazardous processing activities. The MPPF consists of an airlock and processing highbay and lowbay.

Payload Hazardous Servicing Facility (PHSF) – The PHSF is a NASA facility located southeast of the KSC Industrial Area near the SAEF-2 facility. It is designed to accommodate both hazardous and non-hazardous payload processing. Hazardous operations include ordnance installation, loading of liquid propellants, hazardous systems tests, mating of a payload to a solid propellant upper-stage motor, and propellant leak tests.

Defense Secure Communication Satellite (DSCS) Processing Facility (DPF) – The DPF is an USAF facility that accommodates both hazardous and nonhazardous payload processing and encapsulation activities. It is located near the skid strip on CCAFS. It was designed to service a DSCS III class payload consisting of the payload and integrated apogee boost subsystem. The facility can accommodate propellant loads of 9,000 kg (19,800 lb) of liquid bipropellant and/or 9,000 kg (19,800 lb) of solid-propellant motors.

Spacecraft Processing and Integration Facility (SPIF) - The SPIF is an USAF facility designed for hazardous and non-hazardous payload processing and encapsulation. It is located in the Solid Motor Assembly Building (SMAB) on CCAFS near LC-40 and LC-41. It can support loading of liquid fuels and oxidizers, as well as integration of payloads with solid-propellant motors. (NASA 2002)

The fourth support action proposed is to use the SMARF (Figure 2-8). Utilizing this facility as a processing facility for the Falcon 1 and Falcon 9, as well as its payloads would support the horizontal integration of the vehicle stack as planned. It is essential for the vehicle processing facility to be located as close to the Launch Pad as possible to avoid the risks associated with moving the vehicle following check-out to the launch pad at SLC 40. The SMARF provides the only suitable location that is already in existence in the near proximity of the pad. The SMARF would require some refurbishment and specific design alterations to accommodate both hazardous and non-hazardous payload processing. Hazardous operations include ordnance installation and loading of liquid propellants, (AEROSTAR 2007). Prior to using the SMARF for loading fuel, the building will be modified and certified to meet National Fire Protection Association (NFPA) fire protection requirements for electrical systems and equipment including existing crane consoles.

Launch Pad

The launch platform will be the concrete pad over the flame bucket that currently exists at SLC-40 with a launch mount and surround upper deck. The vehicle system transporter/erector serves as a service tower for vehicle umbilical support while vertical. Just before launch, the transporter/erector strongback would be retracted at least 15 degrees from the vehicle. The transporter/erector would be painted initially and again between launches with a non-toxic paint to prevent corrosion of the structure. Mechanical means will be used to remove old paint from the transporter/erector. All paint chips and dust would be collected in a vacuum system for testing and disposal. The transporter/erector would be moved into the preparation facility between launches.

Launch Control Support

Small volumes (less than 300 gallons) of heavy gear oil, hydraulic oil, kerosene and cutting oil (less than one gallon), and a limited supply of various solvents and adhesives would be stored in the shop area in Building 47109, the planned vehicle assembly building or the SMARF for general use in the maintenance of ground equipment. An oxygen/acetylene torch with its associated gases (carbon dioxide and argon gases) may also be used in those buildings on a limited basis. Welding equipment will also be maintained on site for occasional use.

Tentative plans include storing LOX in two 22,000 gallon aboveground storage tanks (AST) on a concrete pad on or near building 47114. Liquid nitrogen may be stored in a 6,000-gallon AST adjacent to the LOX tank or at building 47119. RP-1 would be stored in two 28,000 gallon ASTs located on a concrete pad located at existing building 47103. Gaseous helium would be available

from a high pressure helium gas line which runs parallel to Phillips Parkway. As part of SLC 40 refurbishment, a new helium gas tie-in line would be used to route required helium to SLC 40 for storage in ASME certified storage vessels located in the gas storage area. The storage locations for all Falcon Launch Vehicle Program liquid propellants would afford the same level of separation and protection; with LOX stored near the previous NTO area and RP-1 near the previous hydrogen area.

Safety Systems

A specific safety plan would be developed for the Falcon 1 and Falcon 9 Launch Vehicle Programs to ensure that launch operations are in compliance with applicable regulations, as specified in numerous compliance documents, and by various organizations, including:

- AFSPC 91-710, Range Safety Requirements, as tailored for the Falcon program
- DoD Standards 6055.9, Ammunition and Explosives Safety Standards per AFSPCMAN 91-710;
- Space Wing Instruction (SWI) 32-102, Fire Prevention;
- Air Force Instruction (AFI) 91-110, Nuclear Safety Review and Launch Approval for Space or Missile Use of Radioactive Material and Nuclear Systems; Supplement 1 to AFI 91-110, AFI 40-201, Managing Radioactive Material in the U.S. Air Force; and SWI 40-101, Managing Radioactive Material on Patrick AFB (for minute amounts of radioactive materials typical of scientific equipment potentially present in payloads);
- SWI 31-101, Installation Security Instruction; AFI 31-101, Air Force Installation Security Program; and DoD 5220.22-M, National Industrial Security Program Operating Manual (for DoD missions only);
- AFI 32-1023, Design and Construction Standards and Execution of Facility Construction Projects;
- Air Force Occupational Safety and Health Standards (for DoD missions only);
- National Fire Protection Association, National Fire Codes;
- American National Standards Institute; and
- Occupational Safety and Health Administration (OSHA).

AFSPC 91-710 defines overall safety regulations for CCAFS. This document is tailored for each launch program. All tailoring is performed with the range safety organizations and is approved by the safety organizations. The objective of the range safety program is to ensure that the general public, land masses, and launch area resources are afforded an acceptable level of safety, and that all aspects of pre-launch and launch operations adhere to public law. AFSPC 91-710 (May 2004) provides a framework for review and approval of all hazards associated with construction, pre-launch and launch operations, and incorporates all Air Force DoD, and other applicable health and safety standards.

Range Safety and base Civil Engineering at CCAFS will review and approve the design and construction for refurbishment of the SLC-40 facility according to AFSPCMAN 91-710 and AFMAN 91-201 as tailored to applicable evaluate evacuation plans, AST locations, drain systems, the placement of storage and processing areas, and planned ground operations establish safety clearance zones and safe operations at the launch pad.

SpaceX intends to refurbish the existing, deluge water system at SLC-40 primarily for noise and vibration suppression. Since the thrust energies of the Falcon 1 and Falcon 9 first stage engines are less than those used on the Titan IV launch vehicle which was launched at SLC 40, the

current deluge system size will not be increased. Deluge water systems are used widely throughout CCAFS at other launch complexes for this purpose; those systems normally discharge approximately 100,000 to 300,000 gallons per test/launch activity. For the Falcon 1 a pre-launch test of the deluge system would discharge approximately 4,000 gallons (two minutes at 2,000 gallons per minute) and the launch suppression operation would discharge approximately 6,000 gallons (three minutes at 2,000 gallons per minute) per launch for a total of about 10,000 gallons per launch activity. During a Falcon 9 launch activity the deluge system would discharge approximately nine times the volume of water or about 90,000 gallons. During launch, all water not vaporized and expelled would be contained in the retention basin, analyzed, pumped out, and disposed of off-base at an approved industrial wastewater facility (see Section 3.8, Water Resources). The ground cloud formed by the steam would not contain any hazardous materials.

Finally, the security system at Launch Complex 40 would be maintained and / or refurbished according to Air Force requirements specified in the CSOSA (U.S. Air Force 2002a) and contained in SWI 31-101, AFI 31-101, and DoD 5220.22-M (see Section 2.1.2.1).

2.1.1.7 Recovery Efforts

First Stage

For both the Falcon 1 and Falcon 9 the first stage would drop by parachute approximately 490 nautical miles downrange into the Atlantic Ocean, east of and well beyond the east coast of Florida, and would be recovered by a salvage ship that, during a launch, would be stationed in a Range Safety-designated safety zone near the anticipated area of impact. The salvage ship would be able to locate the first stage by homing in on a transmitter that signals the GPS location, and by strobe light. Recovery operations would consist of using divers to inspect the vehicle, installing safing pins if required, and connecting a cable so that the expended first stage could either be hoisted onto the salvage ship for transport to Port Canaveral or towed into port and once there lifted onto the dock area. If the expended first stage could not be located it would likely be because it had been damaged. It would subsequently sink and therefore, it would not be recovered.

Although the propellants would be burned to depletion during flight, there is a potential for approximately eight gallons of LOX and five gallons of RP-1 to remain in the expended Falcon 1 first stage. These chemicals would not be released into the ocean on impact. The LOX residue would dissipate as gaseous oxygen while the RP-1 residue would likely be trapped within the fuel tank. If RP-1 did escape, the residue would float on the surface of the ocean and dissipate within hours.

The recovered first stage would be returned to the SpaceX facilities at CCAFS via truck or rail from the port. Reuse is a possible option after first stage recovery for both Falcon 1 and Falcon 9. The recovered first stage would also be used as a source of information for continuous program improvement.

Second Stage

The second stage for both vehicles will go into orbit with the payload. For Falcon 1, the second stage will eventually reenter the atmosphere, but will burn up upon reentry. The payload fairing would drop approximately 550 nautical miles downrange into the Atlantic Ocean off the coast of Florida. It would not be recovered as it is expected to be severely damaged on impact and sink. The Falcon 9 second stage is designed to be recoverable. In this event, the stage will re-enter the

atmosphere upon a pre-programmed trajectory to impact in a predetermined position in either the Atlantic Ocean, currently planned off the east coast of Florida, the Pacific Ocean off the coast of California, or the Pacific Ocean near the Marshall Islands.

Dragon Capsule Re-entry and Recovery

The Dragon Capsule has been designed to carry cargo to and from the ISS. As will be discussed in Section 3.0, the Capsule design parameters fit within the “generic” Space Craft analyzed in NASA’s Routine Payload Final EA (2002). After completion of its mission to deliver cargo to the ISS, the Dragon will re-enter the atmosphere on a pre-planned trajectory and will be tracked to a soft-landing in the ocean, and be recovered by a salvage vessel. The capsule may contain down-cargo from ISS for return to Earth, and may also carry trash for disposal. All materials brought down from the station will be delivered to NASA unless directed otherwise. The capsule may or may not be refurbished and re-used. Three recovery zones are being considered and studied. One location is in the Atlantic Ocean off the east coast of Florida, a second location is in the Pacific Ocean off the coast of California and a third location is in the equatorial Pacific near the Marshall Islands. The capsule would be directed along a pre-planned trajectory to bring it back to earth using water landing, (see Figure 2-9). The capsule has an electronic locator beacon and will be located and recovered by a pre-positioned salvage vessel contracted by SpaceX similar to the recovery of the Falcon 9 first and second stages. The capsule will be taken to El Segundo on the west coast, or Cape Canaveral on the east coast for refurbishment.

Debris Analysis

As part of the safety review process, a Falcon 1 debris model had been generated, and a Falcon 9 debris model has also been completed and is included as Appendix C. The debris analysis was developed to be compliant with AFSPCMAN 91-710 and presents estimated debris lists for Flight Termination System activation, explosions, and aerodynamic breakup modes. Additionally, well in advance of any planned mission (launch), SpaceX would also develop a Preliminary Flight Data Package (PFDP) which takes into consideration a trajectory which avoids over-flights of known structures such as oil rigs, and establishes a potential debris corridors for the vehicle (see Section 3.12, Health and Safety). The reliability of the Falcon vehicles is expected to be above 95 percent (less than five percent chance of breakup). The Falcon vehicles are designed to be highly reliable because they minimize staging events and with the Falcon 9 have an “engine out” capability, allowing the vehicle to continue with one failed engine in flight.

2.1.1.8 Wildlife Monitoring and Impact Avoidance

Monitoring of noise level and wildlife responses to launches, would be conducted for the Falcon Launch Vehicle Program to ensure that the program would not adversely affect sensitive species. The monitoring program would be conducted by SpaceX personnel or their representatives. To protect sea turtles from being disorientated, a light management plan will be developed and will comply with the existing 45 SW exterior lighting management instruction.

2.1.2 Refurbishment and Construction Phase

2.1.2.1 Modification of Existing Facilities

SpaceX proposes to make modifications to the existing site (SLC-40), such as building improvements, propellant tank installation, re-installation (or reinitiation) of utilities and resurfacing of the launch water deluge drainage and retention basin, and resurfacing of the

entrance road. Modifications will also include an extension or tie-in to an existing high pressure helium gas pipeline running parallel to Phillips Parkway to the high pressure gas storage area at the SLC 40 site. The extent of modifications required will be determined following a detailed site inspection, compared to specific needs. All work would be restricted to areas inside or near previously disturbed areas of SLC 40 and the entrance road. The SMARF and other supporting facilities in particular would require some retrofitting and refurbishment. Existing systems have been maintained in working order. Design and build actions would be necessary to convert the SMARF into a facility which would be able to accommodate payload processing activities including use of hypergolic fuels.

2.1.2.2 New Facilities

At this time SpaceX plans are to utilize existing facilities, structures, and utility connections currently located at SLC 40. However, a vehicle and payload processing Facility is planned to be built at SLC 40 within the current perimeter of the complex. This facility would require approximately 90,000 sq ft of space (300 ft x 300 ft) plus up to approximately 50 ft x 150 ft of paved area for vehicle maneuvering. This new facility is tentatively planned to be built either in the northeast quadrant of the existing complex, or in the southern half of the complex, both areas that have already been disturbed. A conceptual layout of the facility is shown in Figures 2-10 and 2-11 below. In addition to normal processing activities, fueling of payloads would also occur in this facility, requiring hazardous materials (hypergolic fuels) to be present for short periods of time up to 2 weeks. These materials will be stored in an approved facility when not in use. The facility will be of pre-fabricated steel framework with steel or aluminum sheet walls. The facility will be air conditioned, and the clean-room facility will have an HVAC system with a scrubber system to minimize emissions to the environment in the event of a payload fuel spill inside the facility. A number of other safety systems will support the hazardous fuels and operations to be conducted in this facility. FDEP permitting requirements for the construction and operation of the HVAC system will be adhered to. The construction of this facility would be in accordance with all applicable AF and OSHA regulations.

2.2 DESCRIPTION OF ALTERNATIVES CONSIDERED

2.2.1 Alternative 1: Use of SLC 36

SLC 36 is located east of ICBM road and south of SLC 11. The facility consists of two launch pads (36A and 36B), a deluge basin, support structures, and storage areas (Figures 2-12 and 2-13). The launch pads are approximately 0.25 miles west of the Atlantic Ocean on CCAFS (USAF 2002a). Launch Pad 36A was constructed in 1961, followed by the construction of launch pad 36B in 1964. Both pads were constructed for the Atlas Centaur Missile Program. The first launch took place at 36A on 8 May 1962. The 45 SW owned the property containing SLC 36 from 1959 until 1961 when it was transferred to NASA. However, on 22 January 1990, the 45 SW reacquired SLC 36 in a real property transfer. Pad 36A was used by the USAF, and Pad 36B was used by Lockheed Martin in cooperation with the USAF to launch commercial payloads (HSW 2000). The last Lockheed Martin Atlas rocket was successfully launched from Pad 36B in February 2005. The demolition design for SLC 36A and B was completed in early 2007 and actual facility demolition, including the service towers began in June 2007. SLC 36 is located in ZONE 3 of the CCAFS Zoning plan (Fig 2-14). That zone is currently planned for small and selective medium lift launch missions.

2.2.2 Alternative 2: Use of SLC 47

SLC 47 is located immediately east of Phillips Parkway road and approximately equal distance between SLC 40 to the north and SLC 37 to the south. The facility consists of a small concrete pad and is also located approximately 500 feet west of the Atlantic Ocean beach (Figure 2-15).

While SLC 47 is located in ZONE 1, its current design and purpose is to support small weather related and high altitude sounding rockets. In order to support the Falcon 1 and the Falcon 9 launch vehicles, significant demolition and construction would have to occur. Between 10 and 40 acres of land would be disturbed by this construction activity.

2.2.3 No-Action Alternative

Under the No-Action Alternative, SLC 40 would remain developed, and proceed towards planned demolition. Launch Complex 40 would not be used by the Falcon launch program to meet the National Space Transportation Policy's goal of providing low-cost and reliable access to space. The Commercial Space Launch Act's goal to encourage the use of underutilized government infrastructure and resources to promote commercial investment and use of space would also not be realized at SLC 40. Finally under the No-Action Alternative, SpaceX would not be able to proceed efficiently under the existing announcement to be capable of supporting NASA's continued operation of the ISS once the shuttle program has been phased out.

2.2.4 Alternatives Considered and Eliminated from Further Action in this EA

2.2.4.1 Use of Other Geographical Launch Sites

Kwajalein Atoll

SpaceX currently holds a commercial launch license for the Falcon launch vehicle at USAKA (Kwajalein Atoll). However the use of Kwajalein Atoll presents significant logistical and operational problems. Rocket stage vehicles and payloads must endure a long over-seas journey and once at the Atoll all systems and parts are subjected to a harsh, corrosive atmosphere which leads to potential rise in system failures. While Kwajalein is intended to remain as an alternative launch site, it is not suitable for a primary launch site for the rate of launches anticipated. The use of CCAFS is important since it eliminates those logistic and operational problems, provides facilities to support the desired launch rate, and allows for better mission reliability to the ISS. It is also logistically better suited to support all future ISS related launch activities contracted by NASA. Therefore this location was dismissed from further consideration as an alternative primary launch location.

Alcantara Launch Facility, Brazil

The Alcantara Launch Center is on the Atlantic coast outside of Sao Luis, Brazil (Figure 2-16). The launch pads are used to launch the Satellite Launch Vehicle or Veiculo Lancador de Satellites space boosters, Sonda sounding rockets, meteorological rockets and other science boosters. Brazilian scientists have launched hundreds of sounding rockets since the mid-1960s. Alcantara, also known as CLA, has a launch control center and blockhouse. Its position nearer the equator is said to offer a launch advantage over Cape Canaveral. However, an accident in August 2003 destroyed some of the launch facilities (Space Today Online, 2003). In addition, significant obstacles exist from the US State Department in transporting and operating US made

launch vehicle equipment in foreign countries. Therefore, the Alcantara Launch Facility was dismissed from further consideration as an alternative launch location to CCAFS.

Guiana Space Center, Kouru, French Guiana

The Guiana Space Center is the launch site for the European Ariane vehicles (Figure 2-17). The Guiana Space Center, also known as the Spaceport, is a strategically located facility that provides the optimum operating conditions for Arianespace's commercial launches. Situated close to the equator at 5.3 degrees North latitude, the Spaceport is ideally situated for missions into geostationary orbit. Launching near the equator reduces the energy required for orbit plane change maneuvers. This saves fuel, enabling an increased operational lifetime for Ariane satellite payloads—and, in turn, an improved return on investment for the spacecraft operators. The French Guiana coastline's shape allows for launches into all useful orbits from northward launches to -10.5 degrees, through eastward missions to +93.5 degrees (Arianespace, 2004). As with Brazil, however, operations would be prohibitively expensive due to State Department International Traffic in Arms Regulations. Therefore, the Guiana Space Center was dismissed from further consideration as an alternative launch location to CCAFS.

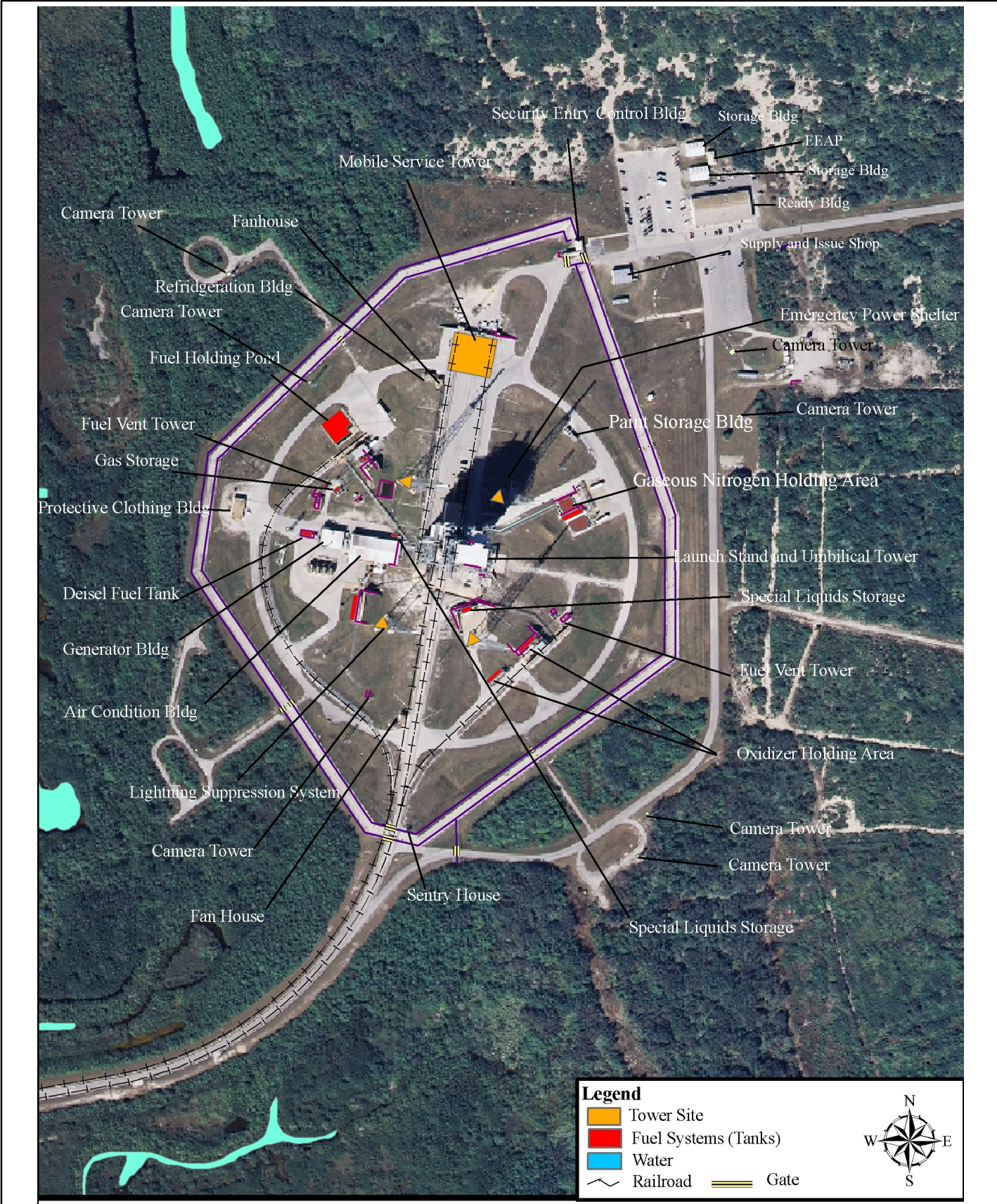

FIGURE 2-1 SLC 40 LAUNCH PAD LOCATION



**Environmental Assessment
Space X Falcon 1 and Falcon 9
Launch Program
Cape Canaveral Air Force Station
Brevard County, Florida**

DRAWN BY: JPK

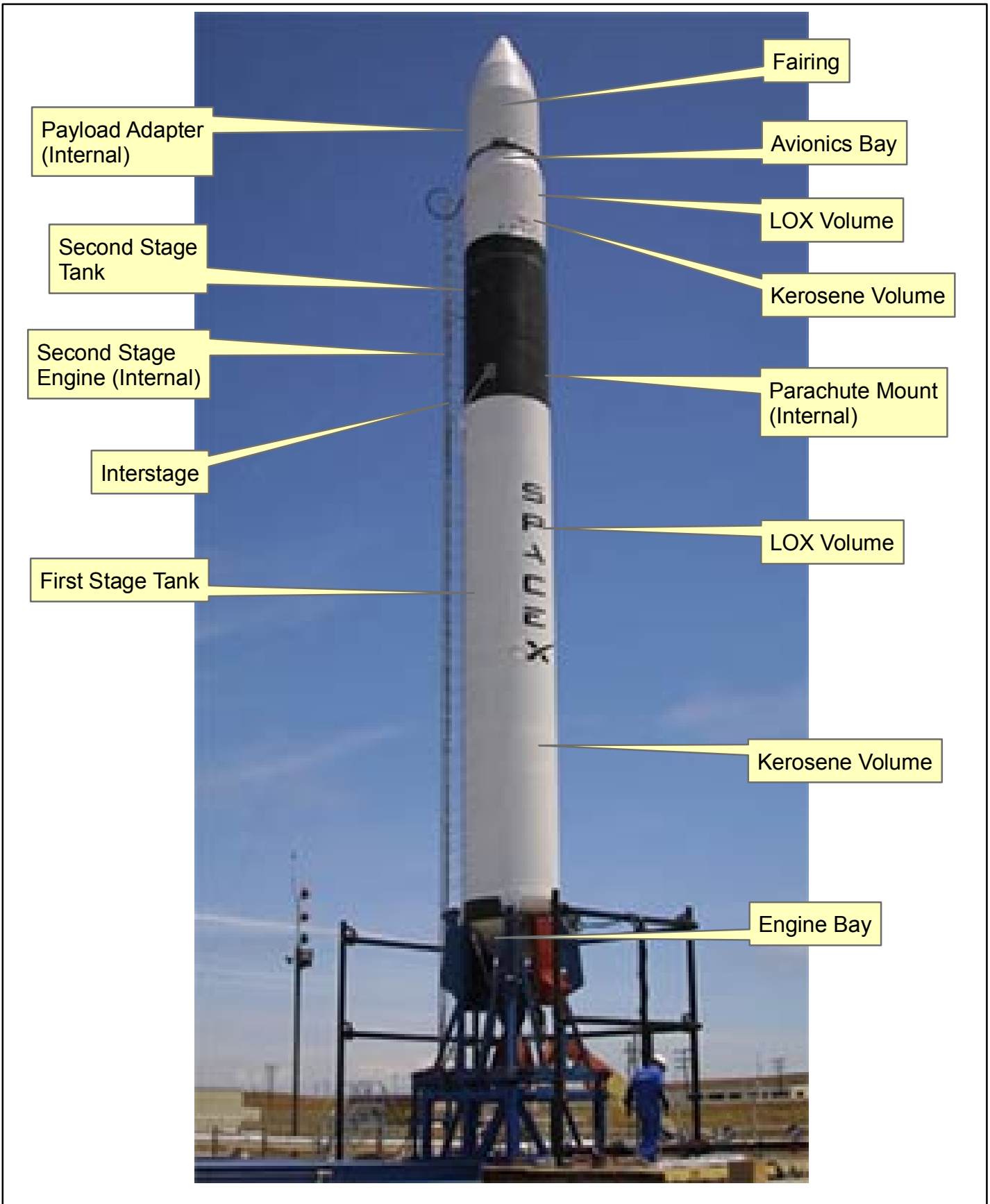



FIGURE 2-2 FALCON 1 LAUNCH VEHICLE

	<p align="center"> Environmental Assessment Space X Falcon 1 and Falcon 9 Launch Program Cape Canaveral Air Force Station Brevard County, Florida </p>	<p align="right">DRAWN BY: JPK</p>
		<p align="right">REFERENCE: PROVIDED BY SPACE X</p>

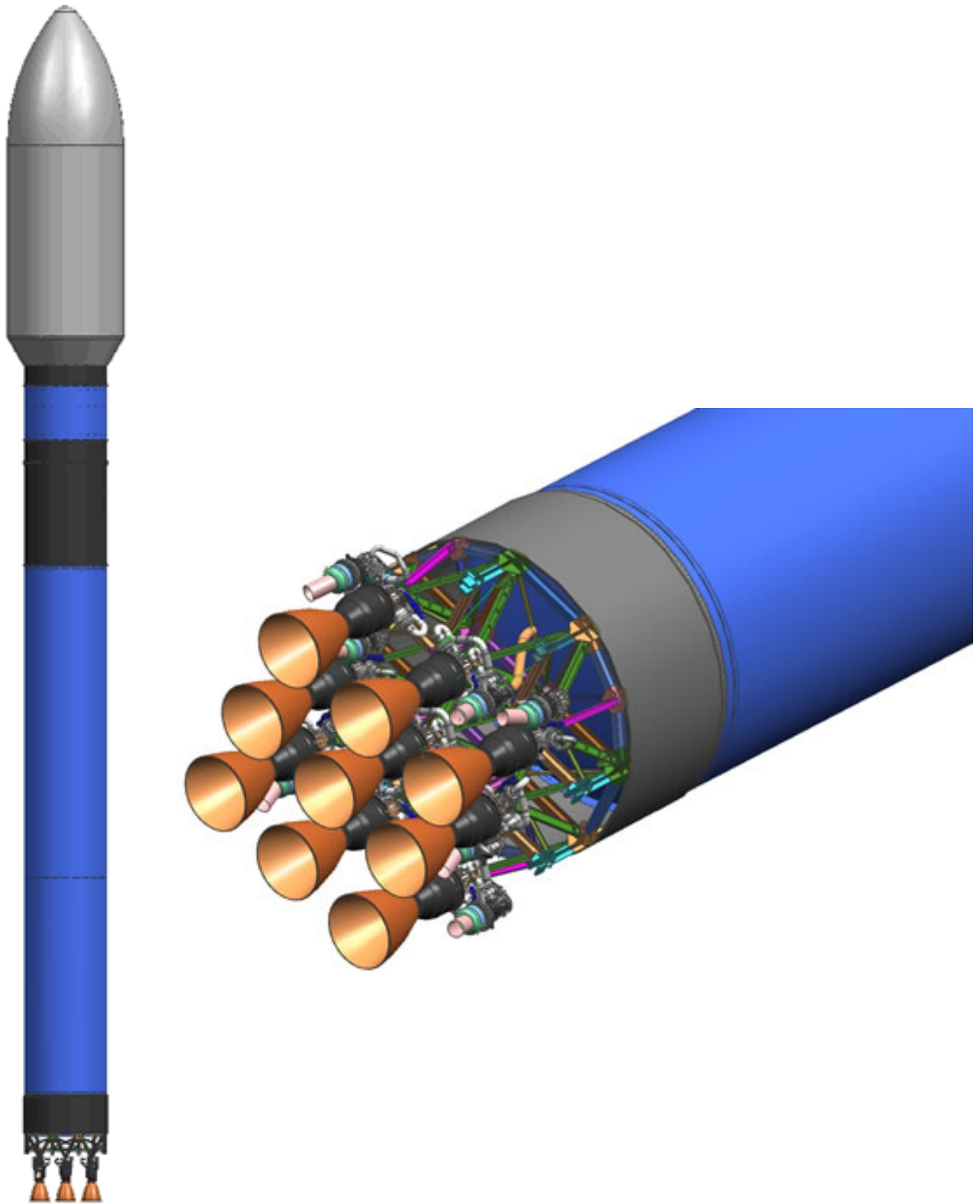

FIGURE 2-3 FALCON 9 LAUNCH VEHICLE



**Environmental Assessment
Space X Falcon 1 and Falcon 9
Launch Program
Cape Canaveral Air Force Station
Brevard County, Florida**

DRAWN BY: JPK

REFERENCE: PROVIDED BY
SPACE X

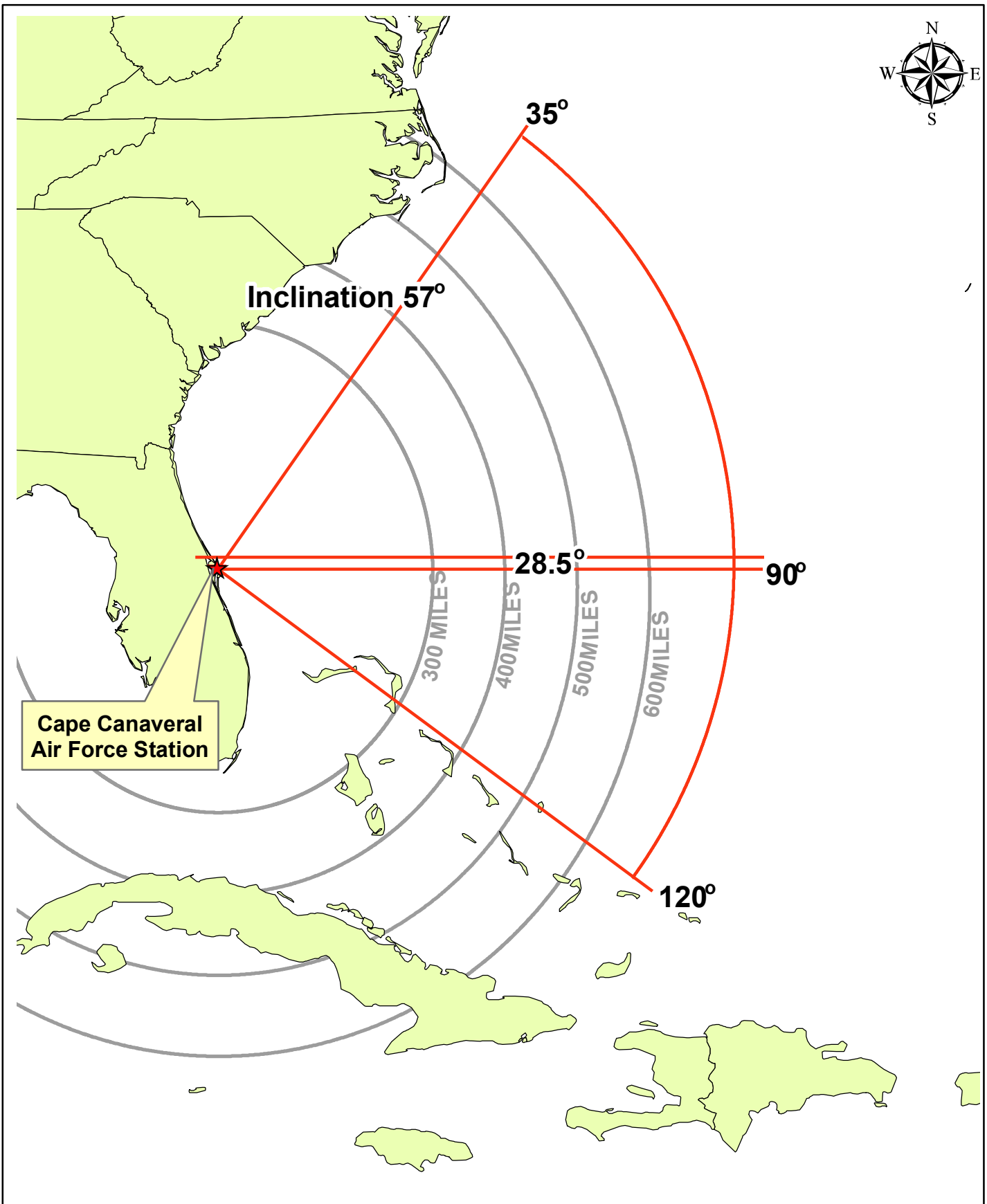

FIGURE 2-4 LAUNCH AZIMUTHS



Environmental Assessment
Space X Falcon 1 and Falcon 9
Launch Program
Cape Canaveral Air Force Station
Brevard County, Florida

DRAWN BY: JPK

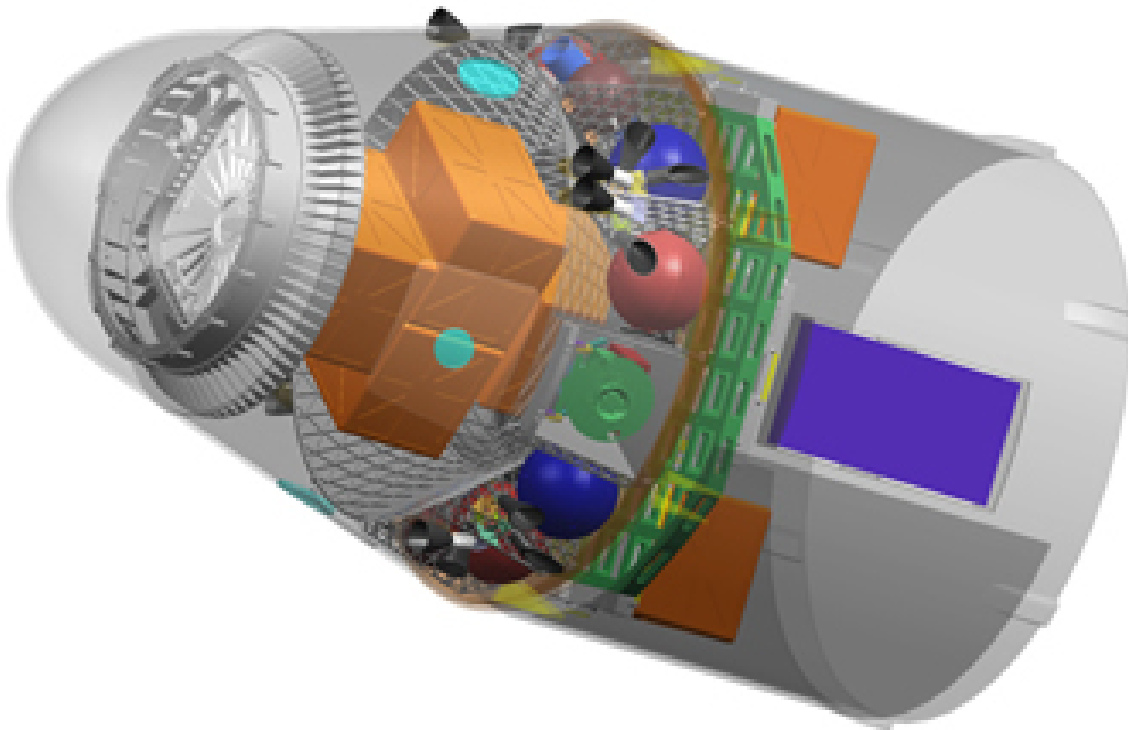
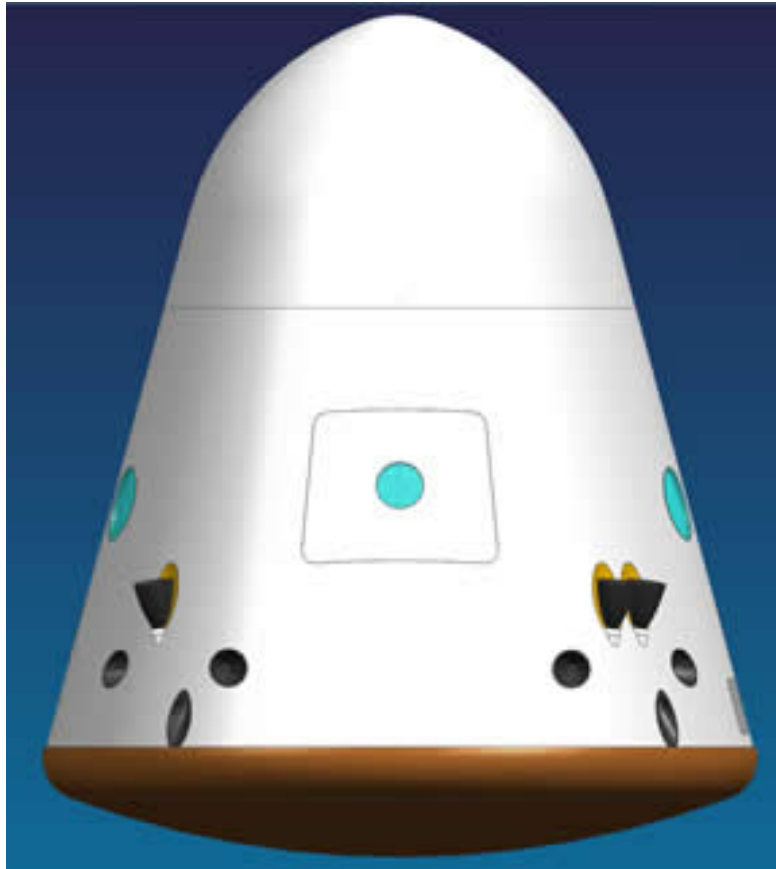

FIG 2-5 DRAGON CAPSULE (CARGO VERSION)



Environmental Assessment
Space X Falcon 1 and Falcon 9
Launch Program
Cape Canaveral Air Force Station
Brevard County, Florida

DRAWN BY: JPK

REFERENCE: PROVIDED BY
SPACE X

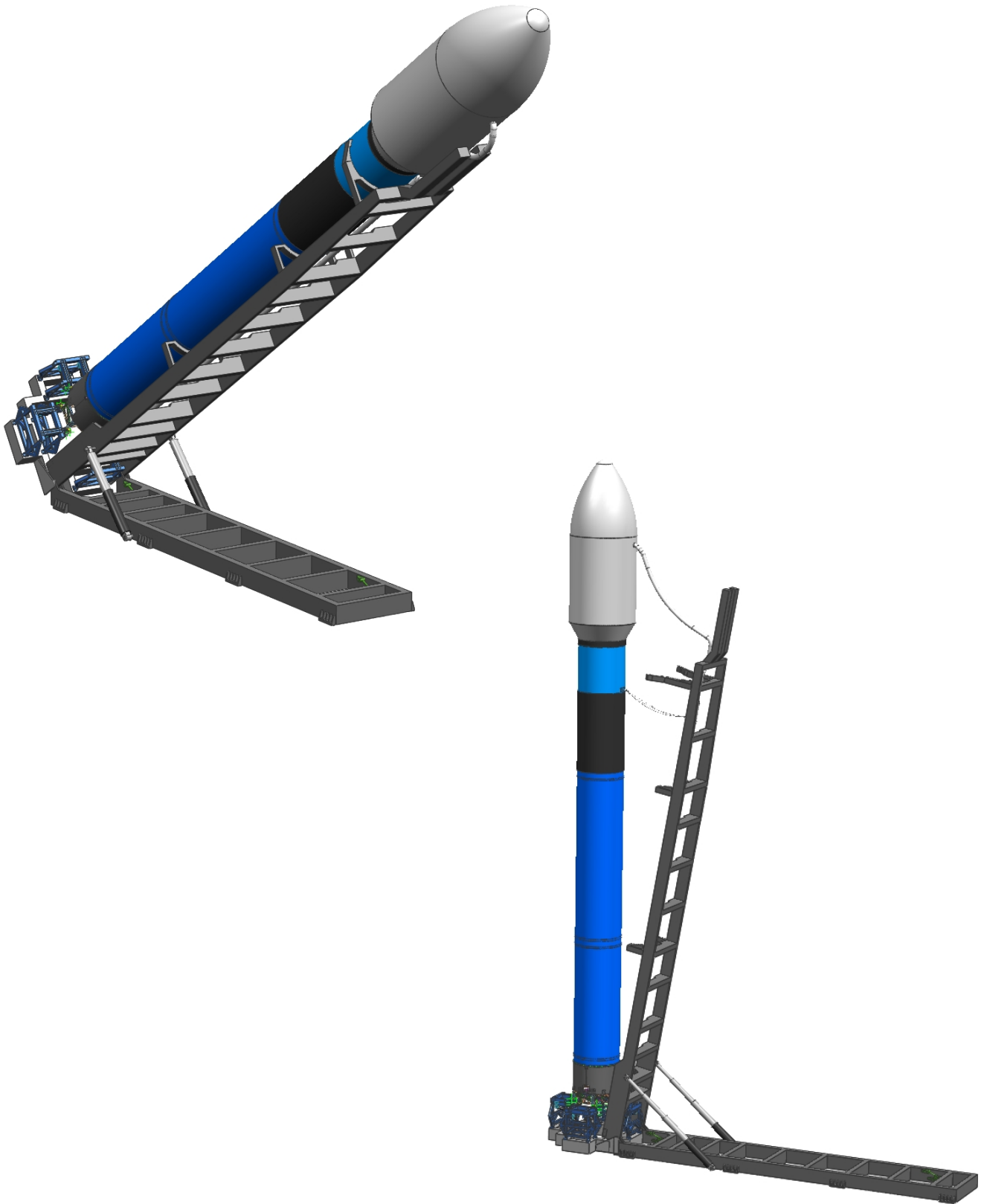

FIG 2-6 FALCON 9 LAUNCH ERECTOR



Environmental Assessment
Space X Falcon 1 and Falcon 9
Launch Program
Cape Canaveral Air Force Station
Brevard County, Florida

DRAWN BY: JPK

REFERENCE: PROVIDED BY
SPACE X

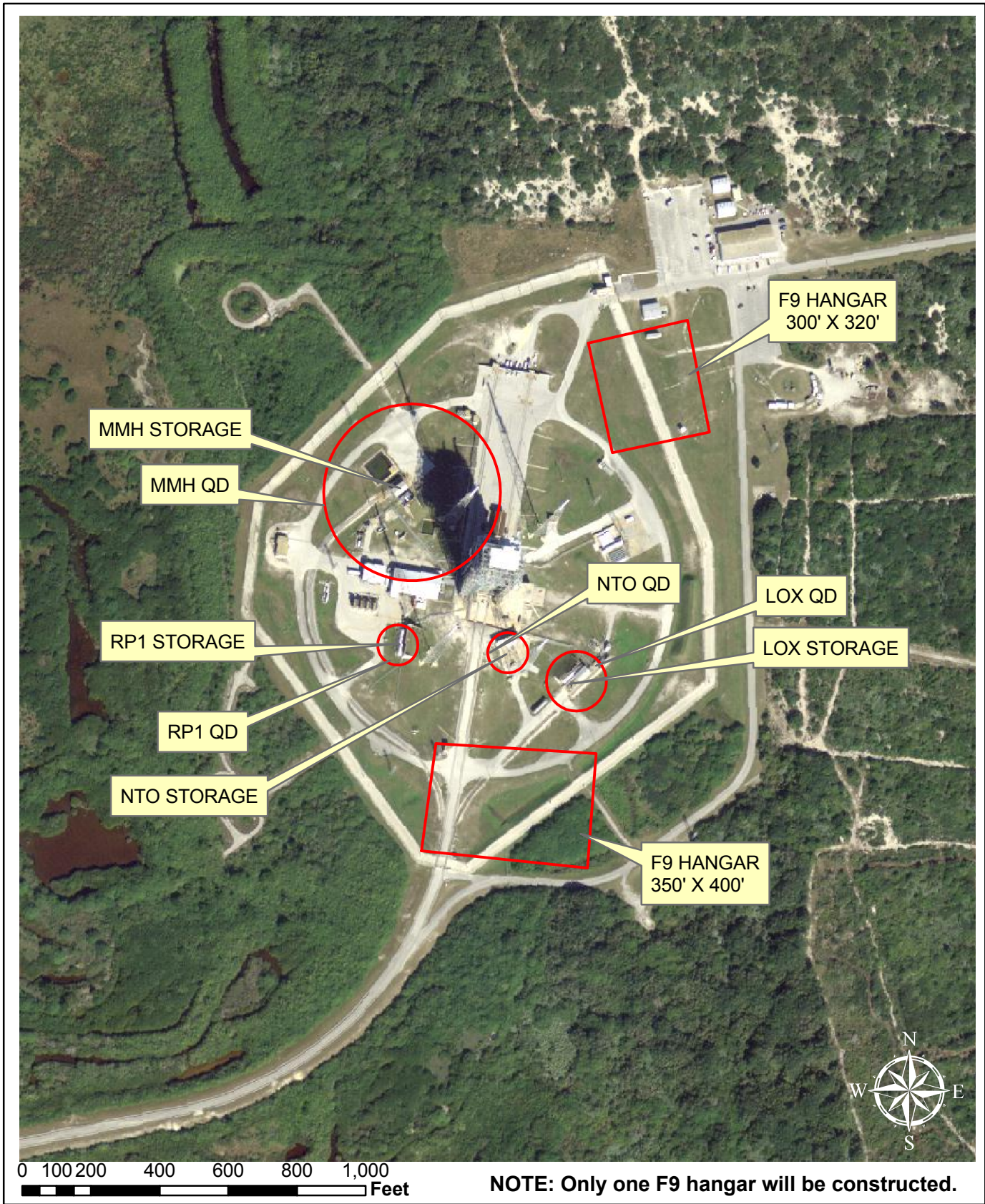

FIG 2-7 SLC 40 (PROPOSED) NEW FALCON SITE LAYOUT



Environmental Assessment
Space X Falcon 1 and Falcon 9
Launch Program
Cape Canaveral Air Force Station
Brevard County, Florida

DRAWN BY: JPK

REFERENCE: PROVIDED BY
SPACE X

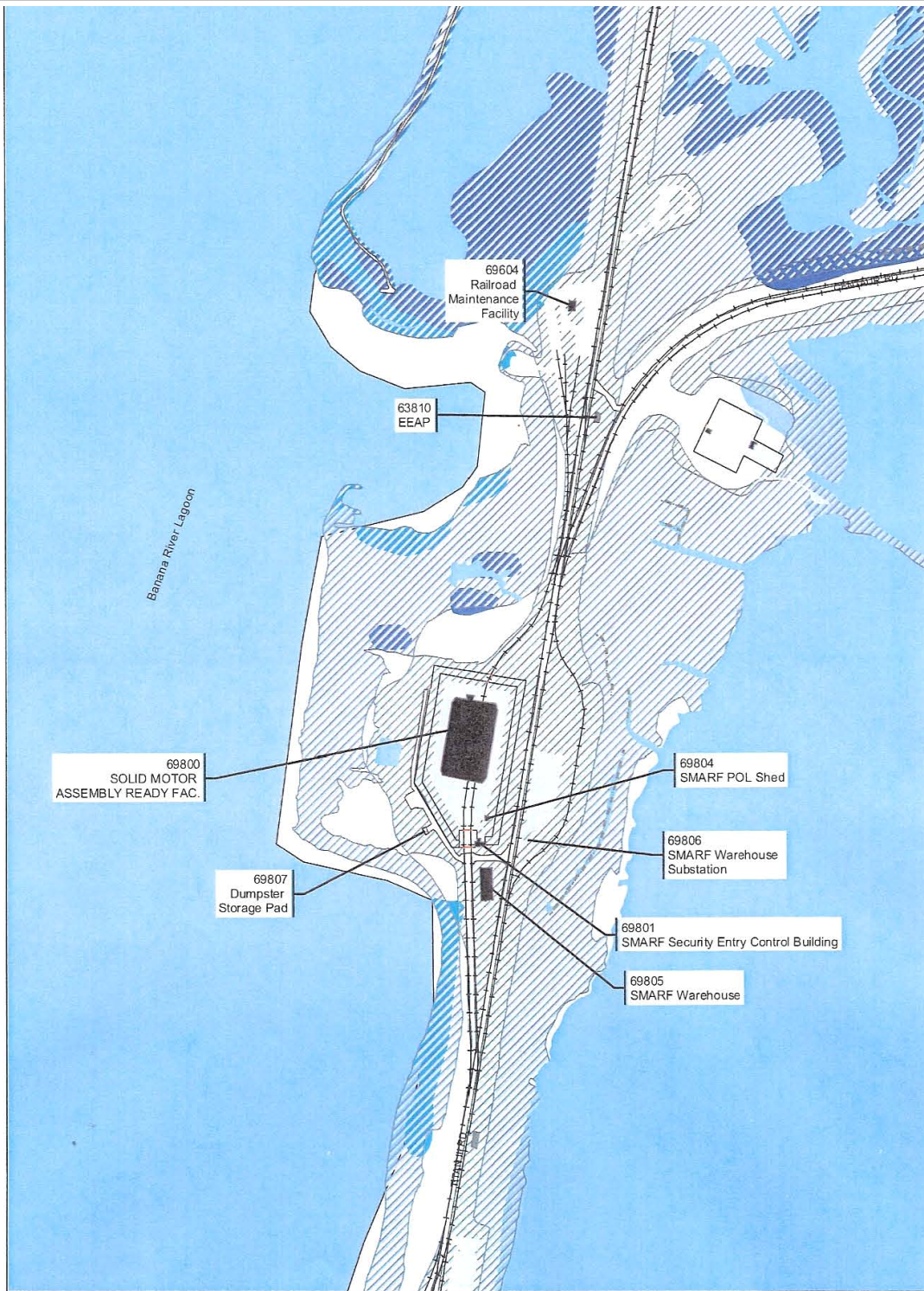

SMARF NWI wetlands and Flood Plains

0 230 460 920 1,380 1,840 Feet

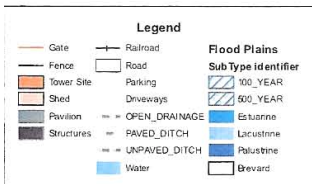

Figure 3-6: SMARF Area NWI Wetlands and Flood Plains



FIG 2-8 SMARF VEHICLE ASSEMBLY BUILDING



Environmental Assessment
 Space X Falcon 1 and Falcon 9
 Launch Program
 Cape Canaveral Air Force Station
 Brevard County, Florida

DRAWN BY: JPK

PREPARED BY:
 SPACE X



FIG 2-9 SIMULATED DRAGON CAPSULE LANDING



**Environmental Assessment
Space X Falcon 1 and Falcon 9
Launch Program
Cape Canaveral Air Force Station
Brevard County, Florida**

DRAWN BY: JPK

REFERENCE: PROVIDED BY
SPACE X

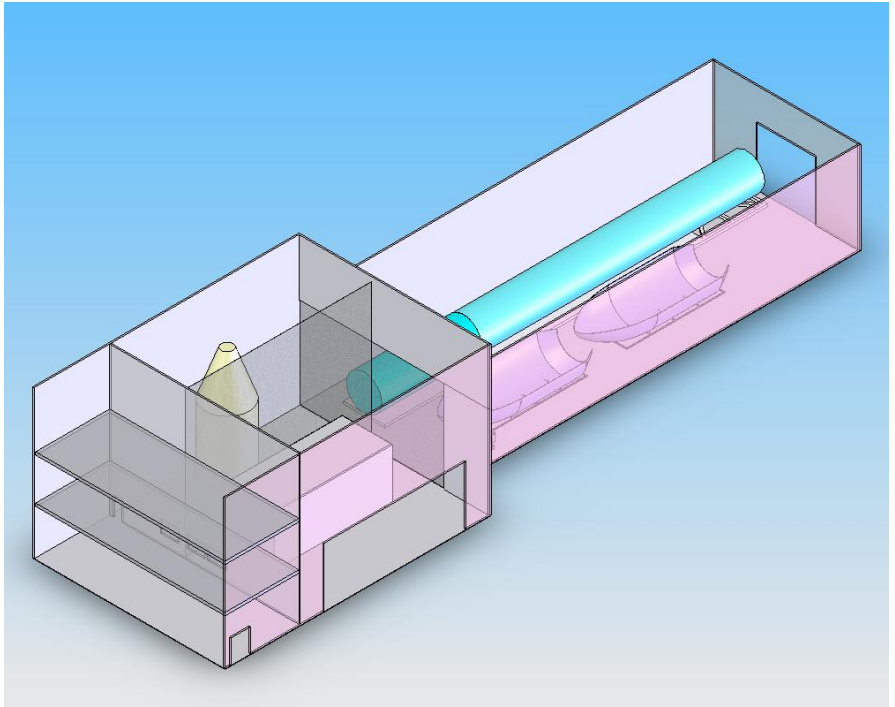
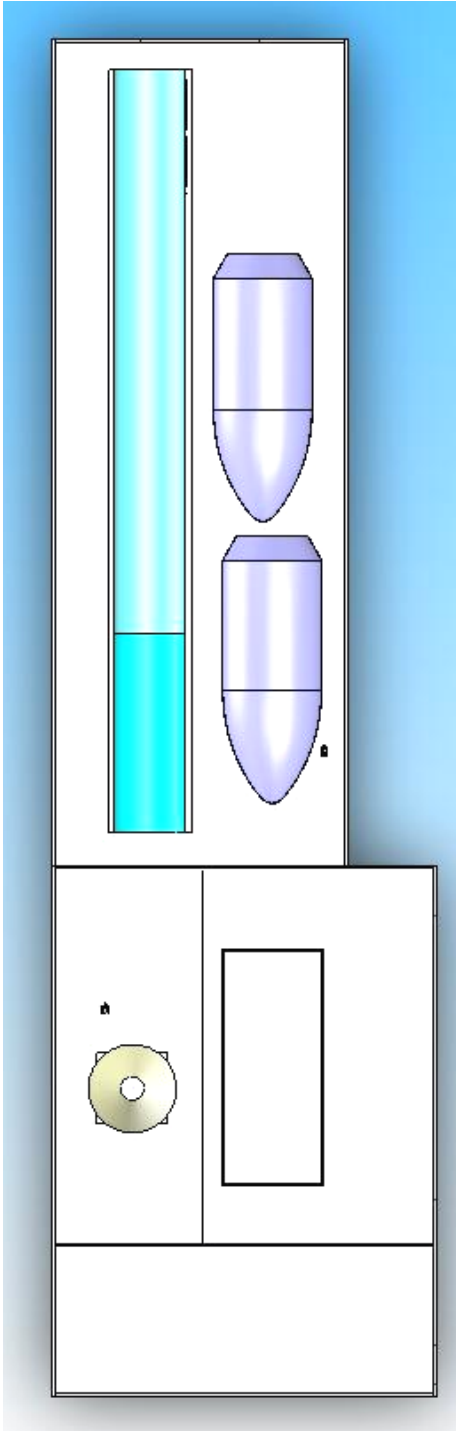

FIGURE 2-10 CONCEPTUAL DRAWING OF PROPOSED SLC 40 ASSEMBLY BUILDING



**Environmental Assessment
Space X Falcon 1 and Falcon 9
Launch Program
Cape Canaveral Air Force Station
Brevard County, Florida**

DRAWN BY: JPK

REFERENCE: PROVIDED BY
SPACE X

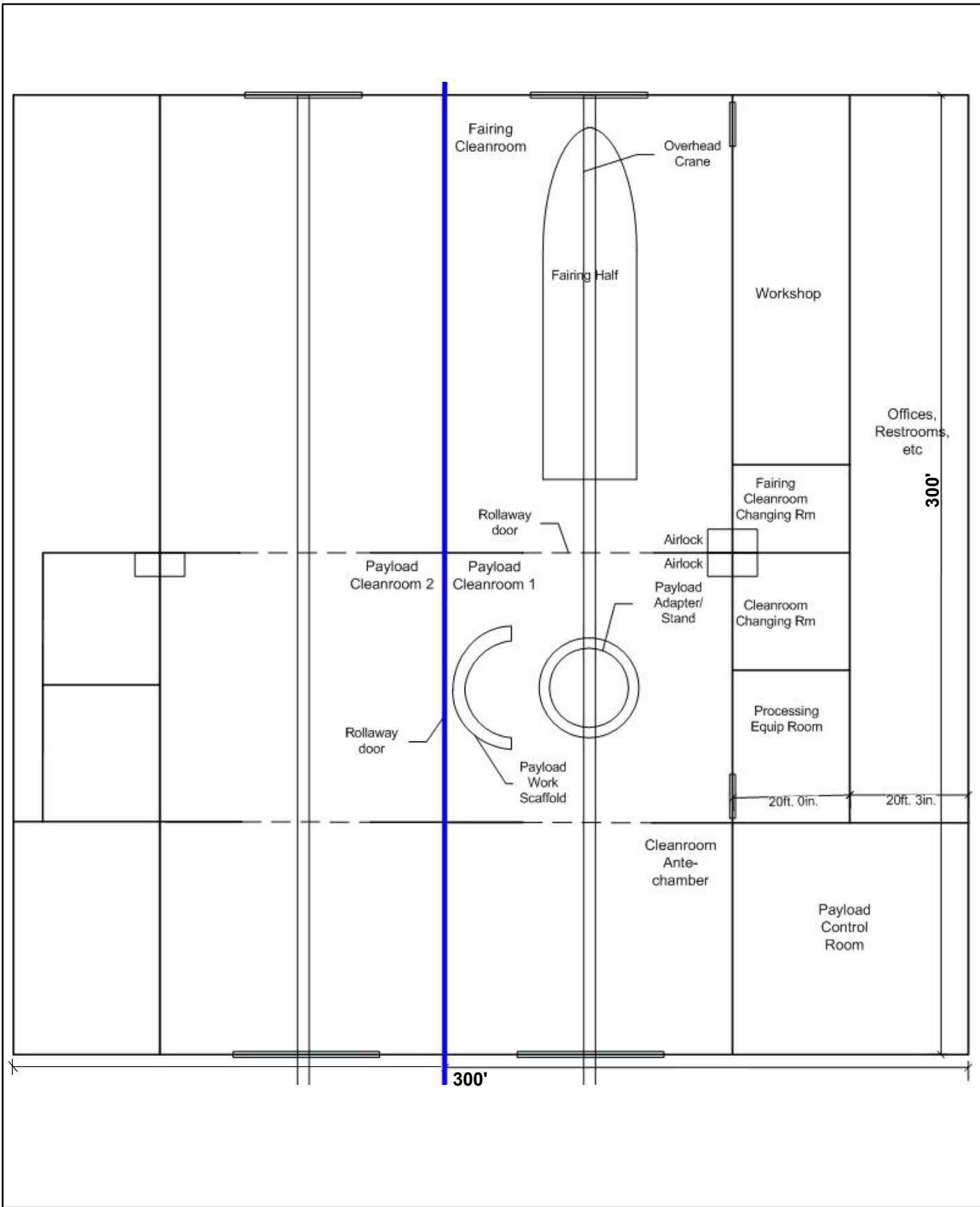

FIG 2-11 PROPOSED SLC 40 ASSEMBLY BUILDING LAYOUT



**Environmental Assessment
Space X Falcon 1 and Falcon 9
Launch Program
Cape Canaveral Air Force Station
Brevard County, Florida**

DRAWN BY: JPK

REFERENCE: PROVIDED BY
SPACE X



FIG 2-12 ALTERNATIVE SITE SLC 36A SITE MAP



Environmental Assessment
 Space X Falcon 1 and Falcon 9
 Launch Program
 Cape Canaveral Air Force Station
 Brevard County, Florida

DRAWN BY: JPK

REFERENCE: PROVIDED BY
 CCAFS



FIG 2-13 ALTERNATIVE SITE SLC 36B SITE MAP



Environmental Assessment
 Space X Falcon 1 and Falcon 9
 Launch Program
 Cape Canaveral Air Force Station
 Brevard County, Florida

DRAWN BY: JPK

REFERENCE: PROVIDED BY
 CCAFS

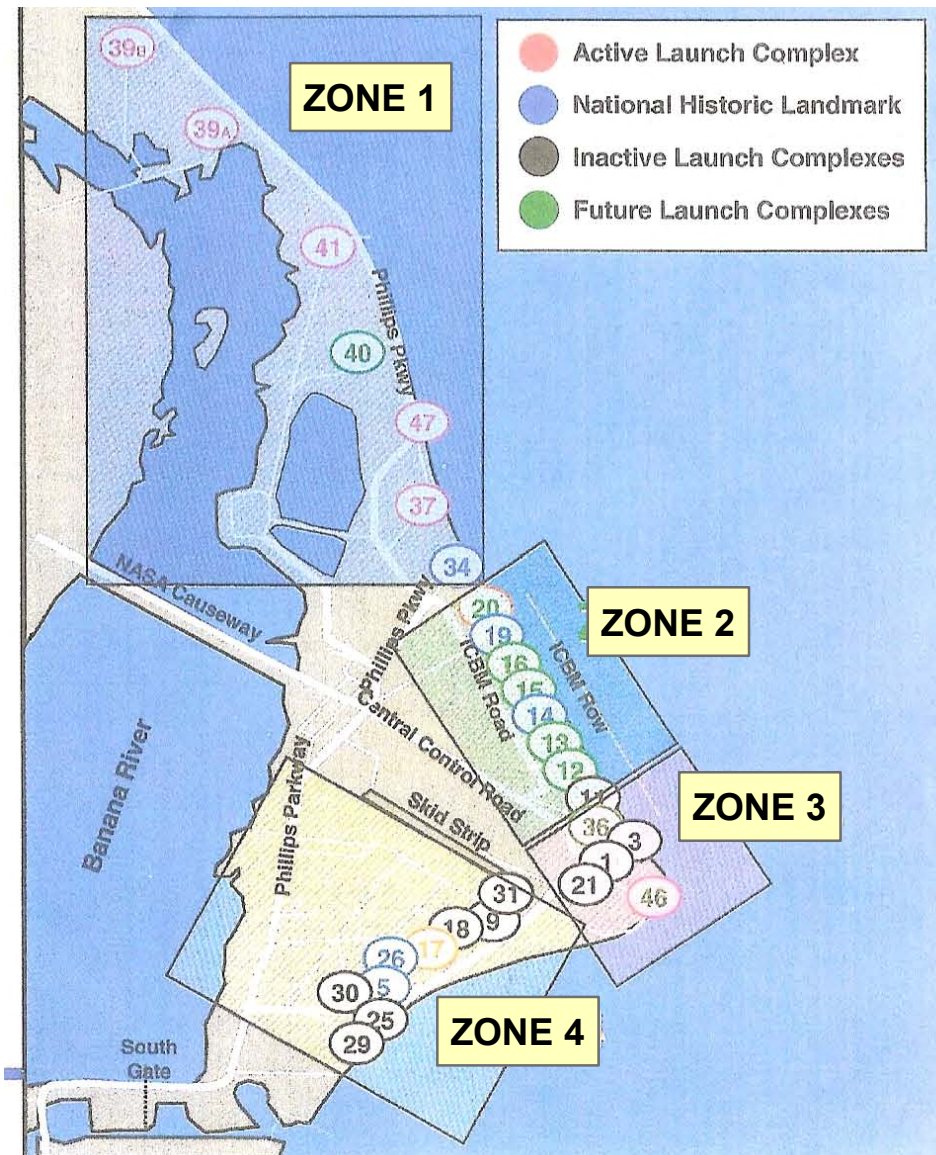

- ZONE 1 : MEDIUM / HEAVY LIFT
- ZONE 2 : FUTURE DOD OPERATIONALLY RESPONSIVE MISSIONS
- ZONE 3 : MULTIPURPOSE; SMALL AND SELECTIVE MEDIUM LIFT
- ZONE 4 : CONSTRAINED OPERATIONS AREA



FIG 2-14 CCAFS ZONING PLAN



Environmental Assessment
 Space X Falcon 1 and Falcon 9
 Launch Program
 Cape Canaveral Air Force Station
 Brevard County, Florida

DRAWN BY: JPK
 REFERENCE: PROVIDED BY
 CCAFS



FIG 2-15 SLC 47 SITE LOCATION MAP



**Environmental Assessment
Space X Falcon 1 and Falcon 9
Launch Program
Cape Canaveral Air Force Station
Brevard County, Florida**

DRAWN BY: JPK

REFERENCE: PROVIDED BY
CCAFS



FIG 2-16 ALCANTARA LAUNCH FACILITY LOCATION



Environmental Assessment
 Space X Falcon 1 and Falcon 9
 Launch Program
 Cape Canaveral Air Force Station
 Brevard County, Florida

DRAWN BY: JPK

REFERENCE: PROVIDED BY
 GOOGLE



FIG 2-17 GUIANA SPACE CENTER LOCATION



Environmental Assessment
 Space X Falcon 1 and Falcon 9
 Launch Program
 Cape Canaveral Air Force Station
 Brevard County, Florida

DRAWN BY: JPK

REFERENCE: PROVIDED BY
 GOOGLE



3.0 AFFECTED ENVIRONMENT

In compliance with NEPA and CEQ regulations, this Section describes the existing environment at CCAFS and the Proposed Action and Alternative locations. For each resource area, a region of influence (ROI) was established. The ROI is an area within which a federal action, program or activity may cause an impact. Generally the ROI will be CCAFS and the specific SLC being discussed. This information serves as a baseline from which to identify and evaluate environmental changes resulting from activities associated with the proposed launching of space vehicles and the Dragon Capsule at CCAFS. These vehicles and payloads are comparatively smaller in size and energies than vehicles such as the Titan III and IV. The greater part of the information contained in this Section is extracted from three existing documents: a) the Evolved Expendable Launch Vehicle (EELV) Environmental Impact Statement, b) The NASA Routine Payload Final Environmental Assessment June 2002 and c) the CCAFS Integrated Natural Resources Management Plan. The reader is referred to these documents for additional information regarding the existing environmental settings at CCAFS.

3.1 LAND USE ZONING / VISUAL RESOURCES

This section contains information which describes the existing environment in terms of land use and zoning for the areas on and surrounding CCAFS. Topics addressed are regional land use and zoning, on-station/base land use and zoning and coastal zone management.

Land use can be defined as the human utilization of land resources for various purposes including economic production, natural resources protection or institutional tasks. Land uses are frequently regulated by management plans, policies, ordinances and regulations that determine the types of actions that are allowable and protect specially designated or environmentally sensitive areas.

Potential issues typically stem from encroachment of one land use or activity on another or an incompatibility between adjacent land uses that leads to encroachment. Compatibility between on-station land uses is addressed by the CCAFS General Plan (45 SW 1995), which contains existing land use maps, future land use maps, and siting standards to guide development. CCAFS coordinates with surrounding local and state jurisdictions to ensure that off-station/base development does not encroach on installation activities, and that installation activities do not encroach on, or create land use and zoning incompatibilities with, off-station/base uses.

The ROI for land use at CCAFS encompasses the station boundaries and potentially affected adjacent lands, including off-station lands within launch safety clear zones or land uses that may be affected by activities on the station.

3.1.1 Regional Land Use and Zoning

Brevard County and the City of Cape Canaveral are the local planning authorities for incorporated and unincorporated areas near CCAFS. Land uses designated by Brevard County for Merritt Island (a barrier island located between the Indian River and the Atlantic Ocean) include residential, commercial, industrial, public facilities, agricultural, recreation and conservation. The City of Cape Canaveral Comprehensive Plan (Ivey, Harris, and Walls, Inc. 1999) designates residential, commercial, industrial, public facilities and recreation and open space land use areas, with continued commercial and industrial uses planned for Port Canaveral. Port Canaveral is also used by NASA, the U.S. Navy, the U.S. Air Force, and the U.S. Coast Guard to support launch and shipping activities. Neither Brevard County nor the City of Cape Canaveral has land use or zoning authority over CCAFS land because it is Federally owned. CCAFS designates its own land use and zoning regulations. The general plans of Brevard County and City of Cape Canaveral designate compatible land uses and zoning around CCAFS.

Kennedy Space Center (KSC), which is north and west of CCAFS, includes predominantly industrial uses associated with NASA launch programs and open space associated with the Merritt Island National Wildlife Refuge. Uses of the river and ocean water areas surrounding CCAFS include commercial fishing, marine recreation and marine transportation. The Cape Canaveral National Seashore is located directly north of CCAFS and is operated by the National Park Service.

3.1.2 CCAFS Land Use and Zoning

CCAFS encompasses an area of 15,800 acres, representing approximately 2 percent of the total land area of Brevard County. Figure 1-2 is a view of CCAFS. Land uses at CCAFS include launch operations, launch and range support, airfield, port operations, station support area and open space. The launch operations land use category is present along the Atlantic Ocean shoreline and includes both inactive and active launch sites and support facilities. The launch and range support area lies west of the launch operations land use area and is divided into two sections by the Skid Strip (airfield). The port operations area is in the southern part of CCAFS and includes facilities for commercial and industrial activities. The major industrial area is located in the center of the western portion of CCAFS, near the Banana River, and is identified as a CCAFS support area category. Although many of the activities on CCAFS are industrial in nature, this land use area also includes administrative, recreational and range support functions. Open space is dispersed throughout the station. There are no public beaches located on CCAFS.

SLC 40 is a designated Solid Waste Management Unit (SWMU). Land Use Controls were implemented as a result of a RFI conducted at SLC 40. The property is prohibited from residential or other non-industrial development without prior written notification to FDEP and USEPA concerning potential land use changes. This Land Use Control Implementation Plan (LUCIP) will remain in effect until changes to applicable Federal and State risk-based clean-up standards occur. (USAF 2005a) In the event of property realignment, transfer, or re-use for non-industrial or non-commercial purposes, assessment and remediation may be necessary to ensure that impacts to the ecological receptors are not increased or to mitigate potential ecological impacts where residual contamination exists.

3.1.3 Coastal Zone Management

Federal activity in, or affecting, a coastal zone requires preparation of a Coastal Zone Consistency Determination, in accordance with the federal Coastal Zone Management Act (CZMA) of 1972, as amended (P.L. 92-583), and implemented by the National Oceanic and Atmospheric Administration (NOAA). This act was passed to preserve, protect, develop and, where possible, restore or enhance the nation's natural coastal zone resources, which include wetlands, floodplains, estuaries, beaches, dunes, barrier islands, coral reefs and fish and wildlife and their habitat. The act also requires the management of coastal development to minimize the loss of life and property caused by improper development in a coastal zone. Responsibility for administering the Coastal Zone Management Program (CZMP) has been delegated to states that have developed state-specific guidelines and requirements. A federal agency must ensure that proposed activities within the coastal zone are consistent with that state's coastal zone management program.

In Brevard County, the Florida Coastal Management Program (FCMP), formed by the Florida Coastal Management Act (FCMA), applies to activities occurring in or affecting the coastal zone. The entire state of Florida is defined as being within the coastal zone. For planning purposes, a "no development" zone has been established in Brevard County and extends from the mean high water level inland 75 feet.

CCAFS has additional siting and facility design standards for construction that require new facilities to be set back at least 150 feet from the coast (ET 1998). The FDEP is the state's lead coastal management agency. The FDEP along with FCMP member agencies will review the coastal zone consistency determination to ensure the proposed action is consistent with the Florida CZMA plan .

3.2 NOISE

3.2.1 General Description

Noise is usually defined as unwanted sound. High-amplitude noise can be unwanted because of potential structural damage. The ROI for this resource includes the area around SLC 40 and the CCAFS land area. It also extends to the closest populated areas which is Cape Canaveral and Cocoa Beach to the south and Merritt Island to the east southeast. The decibel (dB) is the accepted standard unit for the measurement of sound. It is a logarithmic unit that accounts for the large variations in amplitude. Sound levels that have been adjusted to correspond to the frequency sensitivity of the human ear are referred to as A-weighted (dBA) sound pressure levels (AWSPL). If structural damage is a concern, then the overall sound pressure level (OSPL) is used. This quantity has no frequency weighting and therefore includes low frequencies that are not audible but can affect structures from vibration-related impacts.

A number of descriptors have been developed that account for changes in noise with time and provide a cumulative measure of noise exposure. The most widely used cumulative measure is the day-night average sound level (DNL). This is a daylong average of the AWSPL, with a 10-dB penalty applied at night.

A quantity falling between single-event measures like AWSPL and cumulative measures like DNL is the sound exposure level (SEL), a measure of the total sound from a single event combining the level of the sound with its duration. For a sound with an effective duration of one second, SEL is equal to AWSPL. For sounds with longer effective duration, SEL is larger than AWSPL and thus reflects the greater intrusion of the longer sound.

According to U.S. Occupation Safety and Health Administration (OSHA) noise standards, no worker shall be exposed to noise levels higher than 115 dBA. The exposure level of 115 dBA is limited to 15 minutes or less during an 8-hour work shift. The OSHA standards are the maximum allowable noise levels for the personnel in the vicinity of the launch pad.

The largest portion of the total acoustic energy produced by a launch vehicle is usually contained in the low-frequency end of the spectrum (1 to 100 Hz). Launch vehicles also generate sonic booms. A sonic boom, the shock wave resulting from the displacement of air in supersonic flight, differs from other sounds in that it is impulsive and very brief (up to several seconds for launch vehicles). Because a sonic boom is not generated until the vehicle reaches supersonic speeds, the launch site itself does not experience a sonic boom. The entire boom footprint is some distance downrange of the launch site (USAF, 1998).

Descriptors are used to assess and correlate the various effects of noise on humans, including land use compatibility, sleep and speech interference, annoyance, hearing loss, and startle effects. Although derived for humans, these descriptors can also be used to qualitatively assess the effects of noise on wildlife. These descriptors are:

- A-weighted sound level. An A-weighted sound level is the momentary magnitude of sound weighted to approximate the human ear's frequency sensitivity. A-weighted sound levels are typically measured between 20 hertz and 20 kilohertz.
- The long-term equivalent A-weighted sound level (Leq). The Leq is an A-weighted sound level that is "equivalent" to an actual time-varying sound level.
- Day-night average noise level (DNL). The DNL has been adopted by federal agencies as the standard for measuring noise. The DNL is an A-weighted equivalent sound level averaged over a 24-hour period with a 10-decibel (dB) "penalty" added to nighttime sounds (10:00 p.m. to 7:00 a.m.).
- C-weighted sound level. C-weighting measures sound levels in dB, with no adjustment to the noise level over most of the audible frequency range except for a slight de-emphasis of the signal below 100 hertz and above 3,000 hertz. C-weighting is used as a descriptor of low-frequency noise sources, such as blast noise and sonic booms.
- C-weighted day-night level (CDNL). The CDNL is the C-weighted sound level averaged over a 24-hour period, with a 10-dB penalty added for noise occurring between 10:00 p.m. and 7:00 a.m. CDNL is similar to DNL, except that C-weighting is used rather than A-weighting.
- Sound exposure level (SEL). The SEL is the total sound energy in a sound event if that event could be compressed into one second. SEL converts the total sound energy in a given noise event with a given duration into a 1-second equivalent, and, therefore, allows direct comparison between sounds with varying intensities and durations.
- C-weighted sound exposure level (CSEL). The CSEL is a C-weighted SEL.
- Sound pressure level (SPL). The SPL is measured in decibels and corresponds approximately to the minimum audible sound pressure.
- Peak overpressure. Peak overpressure is a measure of changes in air pressure and is measured in units of pounds per square foot. Peak overpressure is often used to measure the magnitude and intensity of sonic booms, particularly with respect to evaluating the potential for structural damage.

Table 3.2-1 shows the A-weighted sounds levels of commonly encountered sounds.

**Table 3.2-1
A-Weighted Sound Levels of Common Sounds**

Common Sounds	Sound Level Range (dB)	Region of Comfort
Threshold of Hearing	0-10	JUST AUDIBLE
Recording Studio	10-20	
Bedroom at Night	20-30	
Quiet Urban Nighttime	30-40	QUIET
Quiet Urban Daytime	40-50	
Air Conditioner at 100 Feet	50-60	
Automobile at 100 Feet Vacuum Cleaner at 10 Feet	60-70	MODERATE
Heavy Truck at 50 Feet	70-80	
Garbage Disposal	80-90	
	90-100	VERY LOUD
Textile Mill Discotheque	100-110	
Oxygen Torch	110-120	
	120-130	UNCOMFORTABLE

* Source: EELV FEIS April, 1998

3.2.2 Ambient Noise Levels

Noise levels around facilities at CCAFS and KSC approximate those of any urban industrial area, reaching levels of 60 to 80 dBA. Additional on-site sources of noise are the aircraft landing facilities at the CCAFS Skid Strip and the KSC Shuttle Landing Facility. Other less frequent but more intense sources of noise in the region are launches from CCAFS and KSC. The relative isolation of the CCAFS and KSC facilities reduces the potential for noise to affect adjacent communities. The closest residential areas to CCAFS are to the east southeast and to the south in the cities of Merritt Island and Cape Canaveral respectively. Each are approximately 7 miles from the SLC 40 launch pad. Expected sound levels in these areas are normally low, with higher levels occurring in industrial areas (Port Canaveral) and along transportation corridors. Residential areas and resorts along the beach would be expected to have low overall noise levels, normally about 45 to 55 dBA. Infrequent aircraft fly-overs and rocket launches from CCAFS and KSC would be expected to increase noise levels for short periods of time.

3.2.3 Operations -Related Noise

Operation-related noise refers to noise generated from activities such as actual launches and also temporary noise during construction or refurbishment activities, and ongoing noise generated from worker traffic to and from the selected site. The highest recorded levels are those produced by launches of the Space Shuttle, which in the launch vicinity can exceed 160 dBA. Space Shuttle launch noise at Port Canaveral would be expected to be typical of those at an industrial facility, reaching levels of 60 to 80 dBA (USAF, 1998). Sonic booms produced during vehicle ascent occur over the Atlantic Ocean and are directed in front of the vehicle and do not impact land areas. Peak overpressures exist from large vehicles such as the Titan IVB approach 49 kg /m² (10 lb/ft²) in focal zones (USAF, 1998). However,

regarding current and past launch programs on CCAFS, neither Atlas, Titan nor Delta launches have been documented to cause any animal mortality or significant impact to wildlife habitat on CCAFS. Operations related noise from the actual launches can be summarized as discussed below.

Three distinct noise events are associated with launch and ascent of a launch vehicle: on-pad engine noise, in-flight engine noise, and sonic booms.

3.2.3.1 Engine Noise

The launch is the major source of operational noise; all other noise sources in the launch area are considered minor compared to launch noise. The operation of launch vehicle engines produces significant sound levels. Generally, four types of noise occur during a launch: (1) combustion noise from the launch vehicle chambers, (2) jet noise generated by the interaction of the exhaust jet and the atmosphere, (3) combustion noise from post-burning of combustion products, and (4) sonic booms. The initial loud, low frequency noise heard in the immediate vicinity of the launch pad is a result of the first three types of noise combined. Sonic boom patterns are oriented according to the launch azimuth and occur a considerable distance away from the launch pad. In 1992 the sound levels for the Delta II were measured at CCAFS (see Table 3.2-2).

**Table 3.2-2
Measured Delta II Sound Levels, July 1992**

Distance from Pad (feet)	Predicted Maximum OSPL	Noise Levels (dB) Measured Maximum OSPL	Measured Maximum AWSPL	Measured A-weighted SEL
1,500	135.4	130.6	120.2	127.5
2,000	132.9	130.4	117.7	125.5
3,000	129.4	125.8	115.1	123.0

*Source: EELV FEIS April, 1998

On-Pad Noise

On-pad engine noise occurs when engines are firing but the vehicle is still on the pad. The engine exhaust is usually turned horizontally by deflectors or an exhaust tunnel. Noise is highly directional, with maximum levels in lobes that are about 45 degrees from the main direction of the deflected exhaust. Noise levels at the vehicle and within the launch complex are high. Because the sound source is at or near ground level, propagation from the launch vehicle to off-site locations is along the ground, with significant attenuation over distance. On-pad noise levels are typically much lower than in-flight noise levels because sound propagates in close proximity to the ground and undergoes significant attenuation when the vehicle is on or near the pad. Model simulated noise levels produced by the Falcon 9 launch vehicle of overall sound pressure levels (OASPLs) is shown in Table 3.2-3. Typically A-weighted OASPLs values are 6-14 dB lower than unweighted OASPLs (SpaceX 2007a).

**Table 3.2-3
Falcon 9 Modeled Noise**

Distance from Pad	Unweighted OASPL
1,000 ft	141 dB
2,500 ft	133 dB
5,000 ft	127 dB
10,000 ft	121 dB
36,960 ft (7 miles)	109 dB

In-Flight Noise

In-flight noise occurs when the vehicle is in the air, clear of the launch pad, and the engine exhaust plume is in line with the vehicle. In the early part of the flight, when the vehicle's motion is primarily vertical, noise contours are circular, particularly for the higher levels near the center. The outer contours tend to be somewhat distorted. They can be stretched out in the launch direction or broadened across the launch direction, depending on specific details of the launch. Because the contours are approximately circular, it is often adequate to summarize noise by giving the sound levels at a few distances from the launch site. On-pad noise contours are much smaller than in-flight contours. The in-flight sound source is also well above the ground and therefore there is less attenuation of the sound as it propagates to large distances.

The major source of in-flight noise is from mixing of the exhaust flow with the atmosphere, combustion noise in the combustion chamber, shock waves and turbulence in the exhaust flow, and occasional combustion noise from the post-burning of fuel-rich combustion products in the atmosphere. The emitted acoustic power from a rocket engine and the frequency spectrum of the noise can be calculated from the number of engines, their size and thrust, and their flow characteristics. Normally, the largest portion of the total acoustic energy is contained in the low-frequency end of the spectrum (1 to 100 hertz).

3.2.3.2 Sonic Booms

Another characteristic of typical launch vehicles is that they reach supersonic (faster than the speed of sound) speeds and will generate sonic booms. A sonic boom, the shock wave resulting from the displacement of air in supersonic flight, differs from other sounds in that it is impulsive and very brief (less than 1 second for aircraft; up to several seconds for launch vehicles). Sonic booms may affect local communities and are generally described by their peak overpressure in pounds per square foot (psf.) and displayed as contours on maps. The contour values represent psf, the unit used for sonic boom overpressures. The contours denote the peak pressure that occurs at each point over the course of the launch and do not represent noise at any one time.

Because a sonic boom is not generated until the vehicle reaches supersonic speeds some time after launch, the launch site itself does not experience a sonic boom. The crescent shape of the typical contours from launch vehicles reflects this "after launch" nature of sonic boom. The entire boom footprint is down track, and the portions of the footprint to the side of the trajectory represent the overpressures caused as the shock wave expands radially from the line of travel of the launch vehicle. The focal zone "super boom" region is very narrow (typically < 100 yards wide and is down track, not on the launch site).

3.2.4 Refurbishment and Construction Related Noise

Noise related to construction, general refurbishment preparing SLC and support buildings for operation,

and launch stand refurbishment activities such as sandblasting would be conducted as normal for procedures on CCAFS currently. A temporary increase in ambient noise levels typically occurs at and near a refurbishment construction sites due to the operation of most construction equipment (e.g., earth moving machinery, cranes, dump trucks, concrete saws). Noise abatement curtains may be used if prolonged noise impacts are expected for any of the proposed work. Typical construction equipment is muffled to not exceed the 85-dBA noise threshold limit value recommended for construction workers in an 8hour day (American Conference of Governmental Industrial Hygienists 1992-1993). In addition, noise diminishes at a rate about 6 dBA for each doubling of distance from the source.

3.3 BIOLOGICAL RESOURCES

This section describes the existing vegetation, both native and naturalized and special status animal species in the ROI which is considered to be the area immediately surrounding the subject SLCs, and within the CCAFS perimeter. Vegetation communities include both upland and wetland habitats. Special status species include threatened and endangered (T&E) species, and species of special concern (SSC) that occur or could potentially occur at CCAFS, and could be affected by construction activities and the effects of launch operations. Sensitive and protected biological resources include plant and animal species listed as threatened or endangered by the USFWS and the FWCC.

3.3.1 Invasive Species

Most of the areas on CCAFS that are disturbed, including roads, utility corridors, and launch complexes, have a healthy invasive species component. Brazilian pepper (*Schinus terebinthifolius*) predominates the invasive flora at CCAFS with six other invasive weeds present in lower densities; the most wide spread of these is Australian pine (*Casuarina equisetifolia*). Australian pine trees grow singly or as small, dense groves scattered across the base. In addition, cogon grass (*Imperata cylindrical*), melaleuca (*Melaleuca quinquenervia*), mistletoe (*Phoradendron serotinum*), and small populations of thistles (*Cirsium* spp.) and nettles (*Urtica* spp.) are present (Invasive Plant Species Control Plan for CCAFS, 2004).

Woody exotics are present outside the fenced area of SLC 40. Brazilian pepper predominate the invasive flora around SLC 40 and the associated former Titan facilities. Within the fence line the vegetation is characterized as mowed and maintained. These exotics are also present around SLC 36 and SLC 47.

3.3.2 Native Vegetation Communities

At least 10 high-quality natural communities of vegetation exist on CCAFS, despite the communities being fragmented by mission-related construction and clearing activities. Parallel to the coastline, CCAFS has a series of ridges and swales that support these communities. These communities include the oak scrub, rosemary scrub, maritime hammock, coastal strand, coastal dunes, grasslands, seagrasses, and three wetland communities (hydric hammock, interdunal swales, and estuarine tidal swamps and marshes). Vegetation on CCAFS, including SLC 40 consists mainly of the indigenous Florida coastal scrub (including oak and rosemary scrub) and xeric and maritime hammocks. These scrub habitats also contain the Brazilian pepper, a non-native aggressive plant, which invades these communities along disturbed areas, and then becomes established as it out competes native species. There are no federally listed plants at CCAFS. Eight species of state listed plants have been documented to be present on CCAFS and are described in the following paragraphs. However, during a biological survey conducted on August 3, 2007, none of those eight species were found within the boundaries of SLCs 40, SMARF, 36A, 36B or the proposed new SLC 47.

Beach-star plant is a small perennial plant with stems arising at intervals. Its numerous leaves, overlapping at the base with recurved leaf blades, give this plant a star-like appearance.

Curtis' Milkweed is found in dry hammocks, scrub, and flatwoods environments. It flowers between April-July following fires and the flowers are greenish white.

Coastal vervain is an endangered perennial with rose-purple flowers, nearly hairless creeping stems and deeply incised or toothed leaves

The **Giant leather fern** has fronds to over 12 ft long. It lives in the swamps, either fresh or brackish, likes some sunshine and is quite sensitive to cold. The large, once pinnate fronds form a solid thicket.

The golden polypody has thin leathery fronds with a bluish color and creeping rhizomes covered with rusty colored scales, which look like hair.

The **Nodding pinweed** is an evergreen, unarmed tree with compact spread. It flowers in yellow-orange spikes. The fruit is an oblong pod, which reveals flat black seeds attached by orange, string like arils.

The **Hand fern** has fronds that are in the shape of a hand, a palm and several fingers.

The **Satin-leaf** is an evergreen shrub or small tree with leaves that are shiny and dark-green. The flowers are bell-shaped and the fleshy fruits are dark-purple, blue or black.

3.3.3 Threatened and Endangered and Species of Special Concern

CCAFS contains habitat utilized by a large number of federal and state- listed species. Listed species that are known to be near (within 100 feet of perimeter fence) SLCs 36A, 36B, 40, 47 and SMARF boundaries and are presented in Table 3.3-1. This section presents the federal and state regulatory requirements for vegetation and wildlife and identifies the federal and state-listed species that may be present on CCAFS.

T a b l e 3 . 3 - 1
Threatened & Endangered Species Flora/Fauna Found at CCAFS

Common Name	Scientific Name	Status	
		Federal	State
Plants			
Beach star	<i>Remirea maritime</i>		E
Coastal vervain	<i>Verbena maritime</i>		E
Curtiss' milkweed	<i>Asclepias curtissii</i>		E
Giant Leather Fern	<i>Acrostichum danaeifolium</i>		CE
Golden polypody	<i>Phlebodium aurea</i>		T
Hand fern	<i>Ophioglossum palmatum</i>		E
Nodding pinweed	<i>Lechea cernua</i>		T
Satin leaf	<i>Chrysophyllum olivaeforme</i>		E
Birds			
Arctic Peregrine Falcon	<i>Falco peregrinus tundrius</i>		E
Bald Eagle	<i>Haliaeetus leucocephalus</i>	T	T
Florida Scrub-Jay	<i>Aphelocoma coerulescens</i>	T	T
Least Tern	<i>Sterna antillarum</i>		T
Piping Plover	<i>Charadrius melodus</i>	T	T
Southeastern American Kestrel	<i>Falco sparverius paulus</i>		T

Common Name	Scientific Name	Status	
		Federal	State
Wood Stork	<i>Mycteria Americana</i>	E	E
Reptiles and Amphibians			
Atlantic Green Turtle	<i>Chelonia mydas</i>	E	E
Atlantic Hawksbill Sea Turtle	<i>Eretmochelys imbricata imbratica</i>	E	E
Atlantic Loggerhead Turtle	<i>Caretta caretta</i>	T	T
American Alligator	<i>Alligator mississippiensis</i>		SSC
Eastern Indigo Snake	<i>Drymarchon corais couperi</i>	T	T
Gopher Frog	<i>Rana capito</i>		SSC
Gopher Tortoise	<i>Gopherus polyphemus</i>		SSC
Kemp's Ridley Sea Turtle	<i>Lepidochelys kempii</i>	E	E
Leatherback Turtle	<i>Dermochelys coriacea</i>	E	E
Mammals			
North Atlantic Right Whale	<i>Eubalena glacialis</i>	E	
Humpback Whale	<i>Magaptera nivaeangliae</i>	E	
Florida Manatee	<i>Trichechus manatus</i>	E	E
Southeastern Beach Mouse	<i>Peromyscus polionotus niveiventris</i>	T	T

CE – Commercially Exploited
S/A – Similar in Appearance

E – Endangered
T – Threatened

SSC – Species of Special Concern

Federal Regulatory Requirements

Endangered Species Act (ESA). The ESA provides for the conservation of ecosystems upon which threatened and endangered species of fish, wildlife, and plants depend, both through Federal action and by encouraging the establishment of State programs. Section 7 of the ESA requires Federal agencies to insure that any action authorized, funded or carried out by them is not likely to jeopardize the continued existence of listed species or modify their critical habitat.

Migratory Bird Treaty Act (MBTA). Under this Act, taking, killing or possessing migratory birds is unlawful.

Bald and Golden Eagle Protection Act. This Act prohibits the taking or possession of, and commerce in, bald and golden eagles.

State Regulatory Requirements

Florida Endangered and Threatened Species Act (FETSA). This Act includes no specific prohibitions or penalties, but does establish the conservation and wise management of endangered and threatened species as State policy.

Endangered Species Protection Act. This Act prohibits the intentional wounding or killing of any fish or wildlife species designated by the Florida Fish and Wildlife Conservation Commission (FWCC) as "endangered", "threatened" or of "special concern". This prohibition also extends to the intentional destruction of the nests of any such species.

3.3.3.1 Rare Habitats Identified

The USAF is committed to the long-term management of all natural areas on the installation and is directed to do so under Air Force Instruction (AFI) 32-7064, Integrated Natural Resources Management. Long-term management objectives are identified in the 45th SW's Integrated Natural Resources Management Plan (INRMP), with specific land management objectives identified in the Scrub-Jay and Sea Turtle Management Plans located in the Appendices of the INRMP. The following paragraphs provide details of the threatened, endangered and special concern species at CCAFS that may be found near the SLCs under consideration.

Birds

The **Florida Scrub-jay** is a Federally protected species. Distribution of the Florida scrub-jay is restricted to scrub communities associated with relic dunal deposits on peninsular Florida. The scrub-jay shows an obligatory reliance on oak species, especially those growing in low dense thickets interspersed with open sandy areas.

The **Piping plover** has the potential to exist on Brevard beaches during the non-breeding season (July-March). The main threat to this species in Florida is disturbance by humans on their primary habitat, the open beaches.

Arctic peregrine falcons use CCAFS dune habitats annually from about September through May as an important wintering area. This crow-sized raptor feeds on other avian species. The large number of birds inhabiting or wintering on CCAFS is assumed to be the primary attraction of these falcons. In addition to an abundant and dependable supply of prey, the falcons also require the standing trunks of dead vegetation adjacent to feeding areas for roosting.

The **American kestrel** is a state-listed threatened species. It is difficult to differentiate this species from the more widespread Southeastern American Kestrel (*Falco sparverius paulus*), which winters in Florida. Observations have been made throughout CCAFS during the winter months only, suggesting that no Southeastern American kestrels occupy CCAFS during the summer months.

The **Bald Eagle** was down-listed to a Federally threatened species in 1998. They are regularly seen utilizing CCAFS as a foraging area. The nests are usually built in tall pine trees near lakes, marshes or coastlines. Bald eagles are regularly observed on CCAFS between September and April.

Wood storks are a Federally-listed endangered species. Wood storks have been observed feeding in the CCAFS drainage canal system. In addition, these birds rest along the canal banks and in adjacent fields.

Great horned owls have been documented to be present at SLC 40.

Least terns are a state-listed threatened species. Least terns nest along sandy or gravel beaches on the southern portion of CCAFS and on gravel rooftops in the industrial area of CCAFS. They are very sensitive to disturbance when nesting and can be very aggressive if their nest is approached. Least terns typically nest along the beach on CCAFS between April and August.

Reptiles and Amphibians

The **American alligator** is Federally-listed as threatened due to similarity of appearance to another endangered species, the American crocodile. Alligators inhabit and reproduce in all CCAFS waters.

Although the **Atlantic Hawksbill** and **Kemp's Ridley** sea turtles are not known to nest on CCAFS beaches, they have been known to occur in the waters off the Florida coast and near shore areas.

Atlantic loggerhead sea turtles are listed as a threatened species by the USFWS. Approximately 80 percent of loggerhead nesting in the southeastern U. S. occurs in Florida. Each year, between May and August, over 3,000 Atlantic loggerhead turtle nests are deposited on the CCAFS beach.

The **Eastern indigo snake** is Federally-listed as a threatened species and has been identified throughout CCAFS from road kills and field collections. The major threats to the indigo snake on CCAFS are habitat loss and vehicle traffic. This primarily diurnal snake is known to occur in most types of habitat and is often associated with inactive gopher tortoise burrows, which can be found on or near most SLCs.

The **Gopher frog** is a state-listed species of special concern in Florida and may reside within the gopher tortoise burrows in areas identified for potential construction.

The **Gopher tortoise** is a state listed species of special concern in the State of Florida, and is Federally-listed in several other regions of the U.S. Gopher tortoises inhabit upland habitats common in central Florida, including scrub, pine flatwoods, and the dune area along beaches. Their diet consists mainly of grasses, grass-like plants, and legumes. It is illegal to take, harm or harass this species. Likewise, the destruction of gopher tortoise burrows constitutes a "take" under this law except as authorized by specific permit. Although the gopher tortoise is not Federally protected in Florida, it is afforded protection by the USAF due to its state ranking and the commensurable use of its burrow by other Federally protected species.

The **Green sea turtle** was Federally-listed as a protected species in 1978. Green turtle breeding populations in Florida and along the Pacific Coast of Mexico are listed as Federally endangered; all others are listed as threatened. Each summer up to 100 green turtle nests are deposited on the CCAFS beach.

The USFWS listed the **Leatherback sea turtle** as an endangered species in 1970. Leatherback nests can be found along the shores of the Atlantic, Pacific, and Indian Oceans. Nesting on CCAFS was first documented in 1986 when a single leatherback nest was recorded by CCAFS biologists.

Fish

Sawfish species inhabit shallow coastal waters of tropical seas and estuaries. They are usually found in shallow waters very close to shore over muddy and sandy bottoms. **Smalltooth sawfish** have been reported in both the Pacific and Atlantic Oceans, but the U.S. population is found only in the Atlantic. The U.S. population is common along the east coast from Florida to Cape Hatteras. The current range of this species has contracted to peninsular Florida. The smalltooth sawfish is very rare in the area and is unlikely to occur at the project site (USAF, 2006a).

Mammals

The **North Atlantic Right Whale** is Federally-listed under the ESA throughout its range and is rarest of all large whale species and is among the rarest of all marine mammal species. They primarily occur in the northwest Atlantic and in coastal or shelf waters during the winter in both hemispheres. Calving takes place in the lower latitudes and coastal waters. Part of the “critical habitat” includes coastal Florida and Georgia, from Sebastian Inlet, Florida to the Altamaha River, Georgia.

The **Humpback Whale** is Federally-listed under the ESA throughout its range which includes the North Atlantic Ocean. They live at the surface of the ocean, specifically in shallow coastline waters. Their breeding grounds are in warm, tropical waters and occur mostly in the winter through early spring and they have been known to transit north and south in the Atlantic off the coast of Florida.

Manatees are one of the few marine mammals known to inhabit the local salt-water lagoon system. Sightings have shown consistent tendencies of the animals to transit along near-shore waters where submerged aquatic vegetation may grow or where channels provide immediate deep water or freshwater access. In June 2004, the FWCC approved new boat speed zones to protect manatees in Brevard County. They are Federally-listed as endangered due to the low population level (approximately 3200) within the continental U.S. The USFWS has designated the Indian and Banana Rivers as critical manatee habitat.

The **Southeastern beach mouse** was listed by the USFWS as a threatened species in 1989. The beach mouse is a sub-species of the numerous, widely distributed old field mouse. Beach mice populations are restricted to the coastal dune and coastal strand communities along Florida’s East Coast.

3.3.3.2 Preferred Alternative (Proposed Action) SLC-40 and the SMARF

Surveys for Threatened and Endangered species and species of special concern were conducted at CCAFS by CCAFS staff and FNAI from 1995 through 2000. Table 3.3-2 below generally identifies the observed habitats of the Florida scrub-jay, gopher tortoise, beach mice and indigos at SLC 40, the SMARF, and at the alternative sites. A biological survey conducted August 3, 2007 revealed that suitable gopher tortoise habitat exists within 100 feet of SLCs 40 and the SMARF. In addition, the biological survey also revealed that suitable habitat for the scrub jays exists within 100 feet of SLCs 40. During the survey, several active gopher tortoise burrows were identified within 100 feet of SLC 40 including one colony immediately north of the security fence with over 20 active burrows. None were found within the SMARF site. and proposed SLC 47 site.

Table 3.3-2 Threatened and Endangered Species

	Scrub-Jay	Gopher Tortoise	SE Beach Mouse	Sea Turtle	Eastern Indigo
SLC 36A	--	S V	V	V	V
SLC 36B	--	V	V	V	V
SLC 40	V	S*V*	V	V	V
SLC 47	V	V	V	V	V
SMARF	--	--	--	--	V

S – The species has been identified as being present on the SLC (within security fenceline)

V– The species has been identified as being present in the immediate vicinity (within 100 feet) of the SLC based on historical data. *denotes verification on August 3, 2007

-- The species is not known to be present based on current survey August 2007

3.3.3.3 Alternative 1- SLCs 36A and SLC 36B

Surveys for Threatened and Endangered species and species of special concern were conducted at CCAFS by CCAFS staff and FNAI from 1995 through 2000. Table 3.3-2 identifies the general observed habitats of the Florida scrub-jay, gopher tortoise, beach mice and indigos for the SLCs 36A and 36B sites. A biological survey conducted August 3, 2007 revealed that suitable gopher tortoise habitat exists within 100 feet of 36A and 36B. Access to SLCs 36A and 36B was limited due to demolition activities in the area. Potential Scrub Jay habitat may occur within 100 feet of SLCs 36A and 36B; however, this could not be confirmed due to limited access around those SLCs due to demolition activities.

3.3.3.4 Alternative 2 - SLC 47

Surveys for Threatened and Endangered species and species of special concern were conducted at CCAFS by CCAFS staff and FNAI from 1995 through 2000. Table 3.3-2 above identifies general observed habitats of the Florida scrub jay, gopher tortoise, beach mice and indigos at the SLC 47 site. A biological survey conducted August 3, 2007 revealed that suitable gopher tortoise habitat exists within 100 feet of SLCs 40; none were found at SLC 47. In addition, the biological survey also revealed that suitable habitat for the scrub jays exists within 100 feet of SLC 47.

3.3.4 Migratory Birds

Cape Canaveral is situated along a major flyway route for migratory birds and therefore home to numerous birds listed on the USFWS migratory bird list, all of which are protected at the Federal level by the Migratory Bird Treaty Act (MBTA). All but a few bird species (i.e. pigeons, European starlings, etc.) found on CCAFS are on this list. Mockingbirds, grackles and great horned owls have been observed nesting on the tower at SLC 40. Prior to any construction or launch activity, a Migratory Bird Nest Removal Permit would be required from FFWCC. This would require that the nest be empty of eggs or young prior to relocation or removal.

3.3.5 Wetlands and Floodplains

Wetlands are defined in AFI 32-7041, Water Quality Compliance (10 December 2003), as those areas that are inundated by surface or ground waters that support plants and animals that need saturated or seasonally saturated soil to grow and reproduce. Wetlands include swamps, marshes, bogs, sloughs, mud flats and natural ponds, and the ecosystems are considered to be some of the most biologically productive of all habitats. The following paragraphs provide compliance requirements for wetlands:

Clean Water Act, Section 404. The main premise of the §404 regulatory program is that no discharge of dredged or fill material can be permitted if a practicable alternative exists which is less damaging to the aquatic environment or if the nation's waters would be significantly degraded.

Executive Order (EO) 11990, *Protection of Wetlands*. The purpose of this EO is to avoid to the extent possible the long and short-term adverse impacts associated with the destruction or modification of wetlands and to avoid direct or indirect support of new construction in wetlands wherever there is a practicable alternative.

Executive Order (EO) 11988, *Floodplain Management*. The purpose of this EO is to consider alternatives to avoid adverse impacts associated with occupancy, modifications, and incompatible development in Floodplains whenever there is a practical alternative.

3.3.5.1 Preferred Alternative (Proposed Action)

Wetlands are present within 300 feet of SLC 40 (and the SMARF) as presented in Fig.3.3-1 and Fig. 3.3-5, respectively.

3.3.5.2 Alternative 1 – SLCs 36A and 36B

Wetlands are located within the boundaries of SLCs 36A and 36B as presented in Figs. 3.3-2 and 3.3-3, respectively.

3.3.5.3 Alternative 2 – SLC 47

Wetlands are located west of SLC 47 as presented in Fig. 3.3-4.

Floodplains

Floodplains are lowland and relatively flat areas adjoining inland and coastal waters that are subject to flooding. The 100-year floodplain is located within the boundary of the following SLCs: SLC 11, 12, 14, 36A, 36B, 46 and the SMARF. The 100-year floodplain is present within 250 feet of the perimeter of all other SLCs. The 500-year floodplain is located within 50 feet of the perimeter of SLC 40. Additionally, a proposed alternate location for the construction of a new SLC to support the Falcon program (SLC 47) would be directly adjacent to the 100-year floodplain.

3.3.5.4 Preferred Alternative (Proposed Action)

The 100-year floodplain is not present within the boundary of SLC 40. The 500 year floodplain skirts the

inner edge of the northwest boundary of the (SMARF). The floodplain boundary is presented in Fig. (Fig. 3.3-5)

3.3.5.5 Alternative 1 – SLCs 36A and 36B

The 100-year floodplain is present within SLCs 36A and 36B existing boundaries. The floodplain boundary is presented in Figures 3.3-2 and 3.3-3, respectively.

3.3.5.6 Alternative 2 – SLC 47

The 100-year floodplain is directly adjacent to a possible boundary of SLC 47. The floodplain boundary is presented in Fig. 3.3-4.

3.3.6 Marine Wildlife and Essential Fish Habitat (EFH)

Essential Fish Habitat (EFH) can generally be defined as the waters and substrates necessary to fish for all stages of their life cycle. As Discussed in the Threatened and Endangered Species section, the Manatee, Sea Turtle and Smalltooth sawfish are found in waters surrounding the CCAFS. These waters contain EFH for various species and projects occurring around or in the waters surrounding CCAFS must follow EFH regulations, as described below.

Federally funded projects or projects occurring on Federal property are required to address EFH requirements, as mandated by the 1996 amendments to the Magnuson-Steven Fishery Conservation and Management Act (MSFCMA). Regional Fishery Management Officials (FMOs) are responsible for designating EFH in their management plans for all managed species with the Exclusive Economic Zone (EEZ), which is a managed fisheries area that extends from the shoreline to 200 miles offshore along the coastline of U.S. waters. For the marine area surrounding CCAFS, the South Atlantic Fishery Management Council (SAFMC) is the managing body. The SAFMC currently manages for several types of organisms in the vicinity of Cape Canaveral: The South Atlantic Snapper-Grouper complex, South Atlantic shrimps, Coastal Migratory Pelagic species, Highly Migratory species, Red Drum, Spiny Lobster, Golden Crab, Calico Scallop and *Sargassum*.

In addition to EFH designations, Habitat Areas of Particular Concern (HAPCs) have been designated within areas of EFH. HAPCs are localized areas that are vulnerable to degradation or are especially important ecologically. They are identified by fishery management councils and conservation priorities are set for these areas because they play important roles in the life cycles of federally managed fish species. The SAFMC has designated areas within the vicinity of Cape Canaveral as EFH-HAPCs for the species within its jurisdiction: penaeid and rock shrimp, red drum, snapper-grouper species complex, coastal migratory pelagic species, *Sargassum*, and live/hard bottom habitat.

Essential fish habitat for the snapper-grouper species complex includes coral reefs, live/hard bottom habitats, submerged aquatic vegetation, artificial reefs, and medium to high profile outcroppings on and around the shelf break zone from shore to at least 600 feet (at least 2000 feet for wreckfish). Included as EFH is the spawning area above the adult habitat and the additional pelagic environment, including *Sargassum*.

Areas inshore of the 100-foot contour, estuarine emergent vegetated wetlands, tidal creeks, estuarine scrub/shrub, oyster reefs and shell banks, unconsolidated bottom (soft sediments), artificial reefs, coral reefs, and live/hard bottom habitats are also EFH for specific life stages of estuarine-dependant and nearshore snapper-grouper species. Essential fish habitat for penaeid shrimp includes inshore estuarine

nursery areas (these are also designated as HAPCs), offshore marine habitats used for spawning and growth to maturity, and interconnecting water bodies. Essential fish habitat for rock shrimp consists of offshore terrigenous and biogenic sand bottom habitats found at depths of 58 to 582 feet. Essential fish habitat also includes the shelf current systems near Cape Canaveral, which provide major transport mechanisms affecting planktonic larval rock shrimp. The Oculina Bank HAPC may serve as nursery habitat and provide refuge for rock shrimp.

Essential fish habitat for coastal migratory pelagic species includes sandy shoals and offshore bars, all coastal inlets, designated nursery habitats, and high profile rocky bottom and barrier island ocean-side waters. This extends from the surf to the shelf break zone from the Gulf Stream shoreward, including *Sargassum*.

3.4 CULTURAL RESOURCES

Cultural resources include prehistoric and historic sites, structures, districts, artifacts or any other physical evidence of human activity considered important to a culture, subculture or community for scientific, traditional, religious or any other reasons. For ease of discussion, cultural resources have been divided into archaeological resources (prehistoric and historic), historic buildings and structures, and native populations/traditional resources (e.g., Native American sacred or ceremonial sites). There is no scientific or physical evidence for paleontological resources at CCAFS. The ROI for the cultural resource includes CCAFS land as well as SLC 40, 36 A/B, and SLC 47.

3.4.1 Regulatory Framework

Numerous laws and regulations require that possible effects to cultural resources be considered during the planning and execution of federal undertakings. These laws and regulations stipulate a process of compliance, define the responsibilities of the federal agency proposing the action and prescribe the relationship among other involved agencies (e.g., the State Historic Preservation Officer (SHPO) and the Advisory Council on Historic Preservation). In addition to the NEPA, the primary laws that pertain to the treatment of cultural resources during environmental analysis are the National Historic Preservation Act (NHPA) (1996) (especially Sections 106 and 110), the ARPA (1979), the American Indian Religious Freedom Act (AIRFA) (1978) and the Native American Graves Protection and Repatriation Act (NAGPRA) (1990).

Only those cultural resources determined to be potentially significant under the above-cited legislation are subject to protection from adverse impacts resulting from an undertaking. To be considered significant, a cultural resource must meet one or more of the criteria established by the National Park Service that would make that resource eligible for inclusion in the National Register of Historic Places (National Register). The term "eligible for inclusion in the National Register" includes all properties that meet the National Register listing criteria, which are specified in the Department of the Interior regulations Title 36 CFR 60.4 and National Register Bulletin 15. Therefore, sites not yet evaluated, and at least 50 years old, may be considered potentially eligible for inclusion in the National Register and, as such, are afforded the same regulatory consideration as nominated properties. Whether prehistoric, historic, or traditional, significant cultural resources are referred to as "historic properties."

3.4.2 Prehistoric and Historic Archaeological Resources

Archaeological investigations at CCAFS indicate that human occupation of the area first occurred approximately 4,000 years ago. Early settlement was focused within the Banana River salt

marsh environment; however, over time, site distribution and size fluctuated, and there is archaeological evidence that the entire peninsula was exploited for a wide variety of marine, estuarine and terrestrial resources. Occupation of the area is divided into seven cultural periods: the Archaic Period, the Orange Period, the Transitional Period, the Malabar I, IIA, and IIB Periods and the Protohistoric (550 - 350 years ago (A.D. 1450-1650) or Seminole Period.

3.4.3 Historic Buildings and Structures

In 1949, the Cape Canaveral Long-Range Proving Ground was formally established under the direction of the Air Force. Construction of the first missile launch pads, support facilities, and down-range tracking stations began in 1950, and throughout that decade military facilities and activities developed at a rapid pace. Various cruise-type missiles were tested during these years and the installation began to support the Intermediate Range and ICBM programs. Activity at the installation peaked in 1966 with more than 30 operational launch complexes.

Historic building and structure surveys at CCAFS include those conducted by the National Park Service (1980); Resource Analysts, Inc. of Bloomington, Indiana (Barton et al. 1983); and the USACE Construction Engineering Research Laboratories (CERL) (McCarthy et al. 1994; Turner et al. 1994).

3.4.4 Native Populations/Traditional Resources

At the time of European contact, the Cape Canaveral and Banana River areas were populated by tribal groups of the Ais Indian tribe. Settlements were described by early explorers as sparse and isolated, and historical accounts indicate that they remained so well into the eighteenth century (New South Associates 1993). The Ais settlements closest to CCAFS were the Ulumay villages along the Banana River. The settlements were numerous, changed with the seasons, and reflected a fishing and gathering subsistence; agriculture was not practiced. Dwellings were temporary, and tools and utensils were typically fashioned of conch shell or gourds.

Significant traditional sites are subject to the same regulations and are afforded the same protection as other types of historic properties. Traditional resources associated with the Ais could include archaeological sites, burial sites, mounds, ceremonial areas, caves, hillocks, water sources, plant habitat or gathering areas or any other natural area important to this culture for religious or heritage reasons. By their nature, traditional resources sites often overlap with (or are components of) archaeological sites. As such, the National Register-listed or -eligible sites (as well as any archaeologically sensitive areas) could also be considered traditional sites or could contain traditional resources elements.

3.4.5 Cultural Resources Associated with SLCs 40, 36A and B, 47

3.4.5.1 Preferred Alternative (Proposed Action)

SLC 40 was designed to support Titan IIIC space missions, which began with the first successful launch on 18 June 1965. In the 1970s, Titan IIICs launched from SLC 40 placed mostly military satellites into very high, geosynchronous equatorial orbits. The last Titan IIIC lifted off SLC 40 in March 1982, followed by the first Titan 34D on 30 October 1982. Refurbishment to upgrade SLC 40 from a Titan 34D configuration to a Titan IV configuration began in July of 1990 (ES 1992). The SMARF was

constructed in 1991. On 15 October 1997, a Titan IVB/Centaur launched from SLC 40 lofted the Cassini orbiter and its attached Huygens probe into space for their journey to Saturn. Nonetheless, SLC 40 and the SMARF are not considered a historic complex and there are no historic properties located in the immediate vicinity. Additionally, there are no known archaeological sites located either within the complex boundary or near SLC 40 (45SW 1999).

3.4.5.2 Alternative 1 - SLCs 36A and 36B

SLC 36 consists of two launch pads (36A and 36B), a deluge basin, support structures and storage areas that were built for the Atlas unmanned launch vehicle program in 1961. Over 100 Atlas/Centaur vehicles were launched from SLC 36. NASA operated SLC 36 through 1990, at which time it was transferred to the USAF to launch the Atlas II and Atlas III series of launch vehicles. Due to its historical importance in the early development of the Atlas and Atlas/Centaur programs, SLC 36 had been determined to be eligible for listing on the National Register of Historic Places. However ultimately it was not listed as a historical place, and following the completion of a Section 106 consultation, demolition of all structures and facilities began in June of 2007. According to the 45th SW Cultural Resources Management Plan (CRMP) prepared by New South Associates (1996), a prehistoric Malabar I site (Florida Master Site File location 8Br1642) was identified just west of the eastern perimeter road around the launch complex. Additionally, a second Malabar Period site or extension of 8 BR 1641 was identified in 2006

3.4.5.3 Alternative 2 - SLC-47

This site is small and consists of a ready building, two concrete pads and a small sounding rocket launcher about 5 feet tall. There are two known archeological sites within one half mile of this proposed site.

3.5 AIR QUALITY

This section describes air quality resources at CCAFS for the atmosphere at altitudes below 914 m (3000 ft), which contains the atmospheric boundary layer for CCAFS. The lower atmosphere, also known as the troposphere, is composed of two layers: 1) the atmospheric boundary layer ranging from 0 to 2,000 m (0 to 6,600 ft) in altitude and 2) the free troposphere ranging from 2,000 to 10,000 m (6,600 to 32,800 ft) in altitude. Rapid mixing within the atmospheric boundary layer insures that chemicals released within the atmospheric boundary layer quickly mix throughout the atmospheric boundary layer. Atmospheric monitoring for chemicals at CCAFS is within the atmospheric boundary layer where people live and work. Therefore the ROI discussed in this Section addresses air quality vertically and horizontally as that air space at CCAFS and the launch sites in relation to and above Brevard County.

3.5.1 Lower Atmosphere

This section addresses air quality resources for the atmospheres at altitudes below 3,000 feet. It describes the federal and state regulatory framework for air and CCAFS's current status with respect to these regulations affecting the lower atmosphere. The lower troposphere experiences removal of rocket emissions during rainfall events and by vertical air movement that draws the emissions to the ground.

3.5.1.1 Regional Climate and Meteorology

Brevard County has one of the most diverse ecosystems in North America due to the rare combination of climates. Brevard County is exposed to a temperate climate to the north and a warm subtropical climate to the south, combining the habitat and environmental needs for a wide variety of animal life (Brevard County Website, November 2006).

Summers are hot & humid with temperatures in the mid-to-upper 90's. Winters are mild with day-time temperatures in the 60-70 degree range. Short periods of cold weather dipping down to the freezing mark can be expected in January & February. Hurricane Season runs from June thru November, and is normally most active between August & October. Central Florida is a transition zone between a tropical climate to the south and a humid subtropical climate to the north. The Florida Peninsula is surrounded by oceanic currents of the Gulf Stream that modify the state's weather, which is punctuated by thunderstorms, lightning and hurricanes (Cape Canaveral Seashore Website, November, 2006). A variety of weather forecasts can be found on the National Weather Service Office (NWSO) website for specific nearby weather monitoring stations in the CCAFS neighboring areas such as with the Melbourne, FL NWS office.

The Melbourne NWSO is a collaborating partner in NASA's Applied Meteorology Unit (AMU). The AMU was created in 1991 as an interagency effort among NASA, the USAF at Patrick AFB and Kennedy Space Center, the National Weather Service Office at Melbourne, and the NWS Spaceflight Meteorology Group (SMG) at NASA's Johnson Space Center in Houston. The function of the AMU is to improve weather support for the space program and to enhance public weather forecasting and warning programs by means of technology transfer from this support to spaceflight operations. An AMU staff of meteorologists and other specialists is collocated with Air Force forecasters at Cape Canaveral Air Station (CCAS).

The principal meteorological conditions that control dispersion are winds and turbulence (or mixing ability) of the atmosphere. The wind direction determines which locations would be affected by a given source. The wind speed, along with the degree of turbulence, controls the volume of air available for pollutant dilution. Atmospheric stability is a measure of the mixing ability of the atmosphere and, therefore, its ability to disperse pollutants. Greater turbulence and mixing are possible as the atmosphere becomes less stable, and thus pollutant dispersion increases. In general, stable conditions occur most frequently during the nighttime and early morning hours.

Localized meteorological effects are measured on a meso-scale basis pre-launch and post launch to document weather conditions both at lower atmosphere and upper atmosphere currently. Various computer models are utilized by the USAF 45th Weather Squadron (45 WS) located at Patrick AFB, FL. The 45 WS provides weather support to America's space program at Patrick AFB, Cape Canaveral Air Station, and NASA Kennedy Space Center on the Atlantic coast of Central Florida. Some of their duties include pursuing forecast improvements and liaison with outside technical agencies such as universities, national laboratories, and contractors. They also provide technical and climatological consultations to 45 WS customers. Range safety requirements are followed prior to and post launch with regard to determining and measuring required meteorological conditions such as temperature, barometric pressure, and wind speeds, and various computer modeling is conducted to predict conditions in the event of a launch failure or accident on surrounding populations. NOAA in cooperation with several related Federal Agencies has developed and is developing and improving stratospheric-tropospheric wind profiler models that help to access upper-air short-period wind changes to continually improve pre-launch risk assessments. The Titan IV Launch Vehicle Program at CCAFS utilized the KSC-50 MHz wind profiler for pre-launch wind evaluation, but also used individual launched weather balloons to assure predicting near real time localized wind speed and

temperature data prior to each scheduled launch. NOAA Environmental Technology Laboratory developed wind profilers such as the KSC-50 MHz and the 915 MHz profiler for characterization of wind and temperature fields for toxic hazard assessment supports risk assessment forecasts for low-level winds on all East Test Range, CCAFS launch vehicles. Extensive forecasting is conducted to minimize possible negative short term effects in air quality in the event of a launch failure or accident.

3.5.1.2 Air Quality and Regulations

CCAFS is located in Brevard County and is classified as attainment with NAAQS and FAAQS. These regulations are contained in CFR Part 51 and F.A.C. 51 and F.A.C. 62 (see Table 3.5-1 below). The CCAFS is considered a major source of air pollution for regulated criteria pollutants, and is now classified as a minor source of regulated HAPs under the current Title V Operating Permit. No conformity determination will be required as the facility is located within NAAQS attainment area for all regulated criteria pollutants. To meet requirements of Section 112(r) of the CAA and 40 CFR Part 68, CCAFS prepared a Risk Management Plan (RMP). This plan is required because CCAFS stores reportable quantities of regulated and extremely hazardous chemicals. The chemical holdings for which RMPs have been prepared are for hydrogen at SLCs 17, 36, and 40, and hydrazine and Aerozine-50 at SLC-40. Hydrogen was removed from the RMP during the most recent revision due to the fuel exemption provision of the RMP regulations (40 CFR Part 68); therefore hydrazine and Aerozine-50 at SLC 40 are the only chemicals addressed in the current RMP.

Air quality at CCAFS, KSC, and VAFB is regulated Federally under Title 40 CFR 50 (National Ambient Air Quality Standards [NAAQS]), Title 40 CFR 51 (Implementation Plans), Title 40 CFR 61 and 63 (National Emission Standards for Hazardous Air Pollutants [NESHAPs]), and Title 40 CFR 70 (Operating Permits).

Air quality for the CCAFS area is also regulated under Rule 62-200 et seq., Florida Administrative Code (F.A.C.). As shown in Table 3.5-1, the Florida Ambient Air Quality Standards (FAAQS) are not significantly different from the NAAQS. Specific regulations that may be applicable to launch complex activation activities include Rule 62-204.240, F.A.C. (Florida Ambient Air Quality Standards [FAAQS]), Rule 62-210, F.A.C. (Stationary Source General Requirements) establishes general requirements for stationary sources of air pollutant emissions and provides criteria for determining the need to obtain an air construction or air operation permit., Rule 62-212, F.A.C. (Stationary Source Preconstruction Permitting), Rule 62-213, F.A.C. (Operating Permits), and Rule 62-242, F.A.C. (Mobile Sources). CCAFS and KSC are classified as major sources because emissions are above major source thresholds. KSC and CCAFS have Title V permits. A summary of both Federal and State of Florida regulatory framework and other air related information is available in Appendix D.

**Table 3.5-1
Florida and National Ambient Air Quality Standards**

Regulated Pollutant	Averaging Time	Florida Standards (a,b) ($\mu\text{g}/\text{m}^3$)	National Primary Standards (c,d) ($\mu\text{g}/\text{m}^3$)	National Secondary Standards (c,e) ($\mu\text{g}/\text{m}^3$)
O ³	1 Hour	235	235	235
CO	8 Hours	10,000	10,000	---
	1 Hour	40,000	40,000	---
NO ₂	Annual	100	100 ^(d)	100 ^(d)
SO ₂	Annual	60	80	---
	24 Hours	260	365	---
	3 Hours	1,300	---	1300
PM ₁₀	Annual	50 ^{(f)(g)}	50 ^{(f)(g)}	50 ^{(f)(g)}
	24 Hours	150	150	150
PM _{2.5}	Annual	15 ^(f)	15 ^(f)	15 ^(f)
	24 Hours	35	35	35
Lead (Pb)	Quarterly	1.5	1.5	1.5

Notes:

(a) Florida standards for ozone, carbon monoxide, sulfur dioxide, nitrogen dioxide and PM10 are values that are not to be exceeded. The lead value is not to be equaled or exceeded.

(b) Values for standards are based on a reference temperature of 25 degrees Celsius ($^{\circ}\text{C}$) and a reference pressure of 760 millimeters (mm) of mercury. All measurements of air quality are to be corrected to a reference temperature of 25 $^{\circ}\text{C}$ and a reference pressure of 760 mm of mercury (1,013.2 millibars).

(c) National standards other than ozone and those based on annual averages or annual arithmetic means are not to be exceeded more than once a year. The ozone standard is attained when the expected number of days per calendar year, with maximum hourly average concentrations above the standards, is equal to or less than one. The lead and annual sulfur dioxide standards are not to be exceeded in a calendar year.

(d) National Primary Standards: The levels of air quality necessary to provide an adequate margin of safety to ensure protection of the public health.

(e) National Secondary Standards: The levels of air quality necessary to provide that the public welfare is safe from any known or anticipated adverse effects of pollutant.

(f) Calculated as arithmetic mean.

(g) The annual ambient concentration average for PM10 was repealed effective 18 December 2006 by the USEPA
 $\mu\text{g}/\text{m}^3$ = micrograms per cubic meter

PM₁₀ = particulate matter equal to or less than 10 microns in diameter

PM_{2.5} = particulate matter equal to or less than 2.5 microns in diameter

Source: 40 CFR 50 and Rule 62-204.240, F.A.C.

Presented below in Table 3.5-2 is a summary of both the 2004 and 2005 CCAFS Air Emissions Inventory Report (most recent) actual and potential annual emissions estimates for all NAAQS and FAAQS regulated criteria pollutants and total HAPs (included in the current Title V Air Operating Permit). Additional HAPs limitations making CCAFS a “synthetic minor” source for HAPs were later added in a permit modification, 25 November 2005. CCAFS remains a Title V “major” source of criteria pollutants.

Table 3.5-2
Summary of CCAFS Criteria Pollutant & HAPs Emissions (Tons per Year-TPY) for 2004 and 2005

Pollutant	2004 Actual (TPY)	2004 Potential (TPY)	2005 Actual (TPY)	2005 Potential (TPY)
PM	170.5	232.82	206.96	270.62
PM10	83.30	99.39	99.00	114.76
NO _x	129.90	141.56	110.53	121.60
SO ₂	8.25	14.29	6.85	6.90
CO	29.96	31.09	25.39	31.80
VOC	17.54	75.11	14.12	72.53
HAPs	7.70	8.11	7.65	18.35

3.5.1.3 Regional Air Quality

CCAFS is located in Brevard County, Florida, and is classified as attainment for all regulated criteria pollutants, for NAAQS and FAAQS standards. Table 3.5-3 below presents recent available Regional total annual emissions data.

Table 3.5-3
Ambient Air Concentrations for Criteria Pollutants near CCAFS and KSC (USAF, 2000a)

Pollutant	Period	Station	1996 (ug/m³)	1997 (ug/m³)	1998 (ug/m³)
Ozone	(1-hr Highest)	Cocoa Beach	180	190	294
	(1-hr Highest)	Palm Bay	180	180	220
CO	(1-hr Highest)	Winter Park	4,600	4,600	4,500
	(8-hr Highest)	Winter Park	2,300	3,400	2,900
NO _x	(Annual)	Winter Park	24	24	21
SO _x	(3-hr Highest)	Winter Park	126	75	76
	(24-hr Highest)	Winter Park	31	18	21
	(Annual)	Winter Park	4	4	5
PM ₁₀	(24-hr Highest)	Merritt Island	74	33	NA
	(24-hr Highest)	Titusville	72	32	157
	(Annual)	Merritt Island	18	18	NA
	(Annual)	Titusville	16	17	21

NA = Not Available
 ug/m³ = micrograms per cubic meter

In 2005, CCAS prepared and submitted an application package to FDEP for modification of the Title V Air Operating Permit (No. 0090005-007-AV) to place limitations on HAPs potential to emit (PTE) for the facility-wide emission sources. Effective 29 November 2005, HAPs maximum facility-wide combined HAPs emissions were limited to less than 24.5 tons per year (TPY) and any facility-wide single regulated HAP to less than 9.5 TPY (Potential to Emit) pursuant to FAC Rule 62-210.200. This modification is construction permit number 0090005-008-AC. Also, CCAFS follows and complies with Air Force Instructions such as (AFI) 32-7040 for tracking and estimating air emissions estimates from point, area, and mobile sources for inclusion in the Title V Air Emissions Inventory.

3.5.2 Upper Atmosphere

The atmosphere above 914 m (3000 ft) includes the free troposphere ranging from 2,000 to 10,000 m (6,600 to 32,800 ft) in altitude, the stratosphere extending from 10,000 m (32,800 ft) to 50,000 m (164,000 ft). These boundaries should be taken as approximate annual mean values as the actual level of the boundary between the troposphere and stratosphere (tropopause) is variable on a seasonal and day-to-day basis. The top of the atmospheric boundary layer and, hence, the bottom of the free troposphere is at 914 m (3000 ft) for CCAFS and KSC (NASA 2002).

3.5.2.1 Troposphere

The upper troposphere ranges from 2,000 m (6,600 ft) to 10,000 m (32,800 ft) and is generally referred to as the free troposphere. This layer is characterized by vigorous mixing driven by convective upwelling, horizontal and vertical wind shears, and mesoscale (tens to hundreds of kilometers or miles) transport and washout of gases that have been introduced into this region by industrial sources. This layer does not contain any uniquely important atmospheric constituents and it does not generally influence air quality in the lower troposphere (i.e., atmospheric boundary layer). The concentrations of gases and particles emitted into the free troposphere by transient sources such as launch vehicles are quickly diluted to very low levels before they can be deposited onto or transported near the ground by precipitation or strong down-welling events (NASA 2002).

3.5.2.2 Stratosphere

The stratosphere extends from 10,000 m (32,800 ft) to 50,000 m (164,000 ft) and is important because of ozone formed within the stratosphere. The stratospheric ozone layer is usually taken to lie between about 16,000 m (52,100 ft) and 26,000 m (84,700 ft) altitude. The stratospheric ozone absorbs most of the most harmful ultraviolet (UV) radiation from the sun. Depletion of ozone following the introduction of man-made materials can result in an increase in solar UV on the ground and so pose a serious ecological and health hazard. The importance and global nature of the ozone layer requires a careful consideration of all sources of perturbations (NASA 2002).

3.6 ORBITAL DEBRIS

This section addresses the potential hazards and environmental impacts associated with man-made orbital debris. The ROI, in this case, is the Falcon space craft's potential orbital tracks around the Earth. Since both the proposed action location (SLC 40) and the two alternative locations (SLC 36 A/B, and SLC47) are ground based, they are not addressed in this section. Orbital debris is a concern as a potential collision hazard to spacecraft including the Dragon Capsule. Large pieces of debris are of concern with respect to re-entry and eventual Earth impact. Space debris can be classified as either natural or man-made objects. The measured amount of man-made debris equals or exceeds that of natural meteoroids at most low-Earth orbit (LEO) altitudes [i.e., below 2,000 km (1,243 mi)]. Man-made debris consists of material left in Earth orbit from the launch, deployment, and deactivation of spacecraft. It exists at all inclinations and primarily at LEO altitudes of approximately 800 to 1000 km (500 to 625 mi) (UN, 1999). Orbital debris moves in many different orbits and directions, at velocities ranging from 3 to over 75 km/s (1.9 to over 47 mi/s) relative to Earth (USAF, 2001). Although space debris is not explicitly mentioned in any U.S. legislation, an Executive Branch policy directive, National Space Policy (September 19, 1996), identifies the following guidance to support major U.S. space policy objectives:

The United States will seek to minimize the creation of space debris. NASA, the Intelligence Community, and the DoD, in cooperation with the private sector, will develop design guidelines for future government procurements of spacecraft, launch vehicles, and services. The design and operation of space tests, experiments and systems, will minimize or reduce accumulation of space debris consistent with mission requirements and cost effectiveness.

3.6.1 Characteristics of Orbital Debris

It is estimated that there are more than 10,000 objects greater than 10 cm (4 inches) in size in orbit, tens of millions between 0.1 and 10 cm (0.039 and 4 inches) in size in orbit, and trillions less than 0.1 cm (0.039 inch) in size in orbit (OSTP, 1995). Most cataloged orbital debris occurs in LEO because most space activity has occurred at those altitudes. LEO occurs at altitudes less than 2,000 km (1,243 mi). The quantity of orbital debris has been growing at a roughly linear rate, and growth is projected to continue into the future (USAF, 1998).

Orbiting objects lose energy through friction with the upper reaches of the atmosphere and various other orbit-perturbing forces. Over time, the object falls into progressively lower orbits and eventually falls to Earth. Once the object enters the measurable atmosphere, atmospheric drag would slow it down rapidly and cause it either to burn up or de-orbit and fall to Earth. Satellites with circular orbital altitudes of less than 400 kilometers (248 miles) may re-enter the atmosphere within a few months, whereas satellites with orbital altitudes greater than 900 kilometers (559 miles) may have lifetimes of 500 years or more (OSTP, 1995).

3.6.2 Hazards to Space Operations from Debris

The effects of launch-vehicle-generated orbital debris impacts on other spacecraft including the Dragon Capsule depend on the altitude, orbit, velocity, angle of impact, and mass of the debris. Debris less than about 0.01 cm (0.004 inch) in diameter can cause surface pitting and erosion. Long-term exposure of payloads to such particles is likely to cause erosion of exterior surfaces and chemical contamination, and may degrade operations of vulnerable components. Debris between 0.01 and 1.0 cm (0.004 and 0.4 inch) in diameter would produce impact damage that can be serious. Objects larger than 1.0 cm (0.4 inch) in diameter can produce catastrophic damage (OSTP, 1995).

3.7 HAZARDOUS MATERIALS/HAZARDOUS WASTE

This Section addresses the existence or use of hazardous materials or the existence or production of hazardous waste at the Proposed Action location (SLC 40), the SMARF, or at either one of the alternative locations (SLC 36 A/B or SLC 47), all of which define the ROI. The section also includes use of, and the proper, or improper disposal methods of those materials.

3.7.1 Hazardous Materials Management

A hazardous material is defined in the Hazardous Materials Transportation Act (HMTA) as a substance or material in a quantity and form which may pose an unreasonable risk to health and safety or property when transported in commerce. Hazardous materials are identified and regulated under the Comprehensive Environmental Response, Compensation, and Liability Act (CERCLA), the Occupational Safety and Health Act (OSHA), the Toxic Substance Control Act (TSCA), the HMTA and the Emergency Planning and Community Right-to-Know Act (EPCRA). Hazardous materials have

been defined in AFI 32-7086, Hazardous Materials Management, to include all items (including medical supply items, but excluding drugs in their finished form and pharmaceuticals in individually-issued items) covered under EPCRA (or other host nation, federal, state or local) tracking requirement, the OSHA HAZCOM Standard, and all Class I and Class II ODS. It does not include munitions or HW.

Numerous types of hazardous materials are used to support the missions and general maintenance operations at CCAFS. Management of hazardous materials, excluding hazardous fuels, is the responsibility of each individual or organization. Each organization has a supply organization and uses a “pharmacy” control approach to track hazardous materials and to minimize hazardous waste generation by minimizing the use of hazardous materials. The Patrick Air Force Base (PAFB) supply system is the primary method of purchasing or obtaining hazardous materials. The Joint Propellants Contractor (JPC) controls the purchase, transport, and temporary storage of hazardous propellants. (USAF, 1996a) Response to spills of hazardous materials is covered under JHB-2000 revision A (March 2002), the Consolidated Comprehensive Emergency Management Plan (hereafter referred to as CCEMP). CCEMP establishes uniform policy guidelines for the effective mitigation of, preparation for, response to, and recovery from a variety of emergency situations. The CCEMP is applicable to all NASA, Air Force, and NASA/Air Force Contractor organizations and to all other Government agencies located at KSC, CCAFS, and Florida Annexes. To ensure continuity of operations, the application of the provisions of the CCEMP will be executed by responding organizations through the Incident Management System (IMS). Resource Conservation and Recovery Act (RCRA) requirements will be accomplished by the directives listed in the respective permits issued to KSC/CCAFS (OPLAN 10-2 Vol II, OPLAN 19-14 and KHB 8800.6).

In the event of a spill of hazardous materials, the Air Force would provide initial emergency spill response; however, the remainder of emergency/corrective actions would be the responsibility of SpaceX. SpaceX is responsible for preparing its own Emergency Response Plan for the Falcon Launch Vehicle Program in accordance with the CCAFS Hazardous Materials Emergency Response Plan. The CCAFS Hazardous Materials Emergency Response Plan ensures that adequate and appropriate guidance, policies, and protocols regarding hazardous material incidents and associated emergency response are available to and followed by all installation personnel and commercial entities. In the event of a spill, SpaceX is responsible for completing all “Emergency Planning and Community Right-to-Know Act” (EPCRA) annual reporting requirements to the State and EPA as defined under SARA Title III. In the event of a spill, SpaceX would also be responsible for completing all State and EPA notifications if the spill/release exceeds reporting thresholds.

The SLC 40 facility has some asbestos containing material (ACM) and lead-based paint (LBP) in various forms. Appendix E contains asbestos and lead-based paint information obtained from cross-referencing the data in an asbestos survey conducted across CCAFS with the facility numbers associated with each SLC under consideration. The LBP information obtained from a LBP survey in the 1995 LBP Management Plan conducted for CCAFS and PAFB. The LBP survey was not all-inclusive and intended to provide guidance on the years and types of buildings in which LBP could potentially be present.

Solid and liquid fuels were used in the Titan rockets at SLC 40. The solid fuels were an epoxy mixture containing aluminum and perchlorates and were formerly stored and assembled at the SMARF. The liquid fuel was an oxidizer/fuel mixture consisting of Aerozine-50 and nitrogen tetroxide, which were stored on site. Both fuels were delivered to the site by rail and tanker truck. Small amounts of hydraulic oils were also historically discharged at SLC 40 and the SMARF.

3.7.2 Hazardous Waste Management

Hazardous waste is defined in RCRA as any solid, liquid, contained gaseous or semi-solid waste, or any combination of wastes that could or do pose a substantial hazard to human health or the environment. Waste may be classified as hazardous because of its toxicity, reactivity, ignitability or corrosivity. In addition, certain types of waste are “listed” or identified as hazardous in 40 CFR 263. In regulatory terms, a RCRA hazardous waste is a waste that appears on one of the four hazardous waste lists (F-list, K-list, P-list, or U-list), or exhibits at least one of four characteristics: ignitability, corrosivity, reactivity, or toxicity.

Hazardous waste management, at CCAFS is regulated under RCRA (40 CFR 260-280) and Rule 62-730, F.A.C. The USAF’s instructions for obtaining and maintaining compliance with hazardous waste regulations has been defined in AFI 32-7042, Solid and Hazardous Waste Compliance. The 45 SW OPLAN 19-14, Petroleum Products and Hazardous Waste Management Plan, outlines specific measures for proper collection, management and disposal of petroleum products/waste and hazardous/non-hazardous wastes. As a commercial entity, SpaceX is responsible for requesting/obtaining its own USEPA hazardous waste generator ID# from the EPA. Where SLCs have been leased from CCAFS by a contractor, the contractor, in this case SpaceX, is responsible for the management and disposal of hazardous wastes. It is the responsibility of each contractor to manage and dispose of all hazardous waste generated. SpaceX would manage all hazardous waste generated from its operations in accordance with all local, state, and federal regulations. All hazardous waste is labeled with the USEPA identification number for each contractor, under which it is transported, treated, and disposed of. All individuals or organizations generating hazardous waste at CCAFS are responsible for administering all applicable regulations and plans regarding hazardous waste.

Individual contractors and organizations maintain their own hazardous waste satellite accumulation points (SAP) and 90-day hazardous waste accumulation areas, in accordance with applicable RCRA regulations. There is no limit to the volume of hazardous waste that can be stored at a 90-day hazardous waste accumulation area, but wastes must be disposed of offsite within 90 days. SpaceX would be responsible for developing its own Hazardous Waste Management Plan for the Falcon Launch Vehicle Program in accordance with the 45th Space Wing Hazardous Waste Management Plan, to document how SpaceX would control hazardous wastes for the program. In addition, all hazardous waste must be handled and disposed per the requirements established by the Federal regulations and the FDEP.

The contractor is responsible for the collection and transport of hazardous wastes (including propellant waste) from the SAPs to a 90-day hazardous accumulation area, then to an offsite permitted treatment, storage, and disposal facility (TSDF). There should not be propellant waste unless there would be a spill, leak, during RP-1 loading for each Falcon Launch vehicle.

The contractor is responsible for ensuring that the management and disposal of all hazardous wastes shall be conducted in accordance with all applicable federal, state, and local regulations. The CCAFS TSDF is not available for storage of any contractor-generated program wastes. The contractor is responsible for the coordination of all environmental emergency response actions at the leased premises.

3.7.3 Installation Restoration Program.

The Installation Restoration Program (IRP) is an Air Force program that identifies, characterizes, and remediates past environmental contamination on Air Force installations. The program has established a process to evaluate past disposal sites, control the migration of contaminants, and control potential hazards to human health and the environment. In response to the Comprehensive Environmental

Response, Compensation and Liability Act (CERCLA) and requirements of Section 211 of the Superfund Amendments and Reauthorization Act (SARA), DoD established the Defense Environmental Restoration Program (DERP) to facilitate clean up of past hazardous waste disposal and spill sites nationwide. Section 105 of SARA mandates that response actions follow the National Oil and Hazardous Substances Pollution Contingency Plan, as promulgated by the U.S. EPA. AFI 32-7020, Environmental Restoration Program, implements the DERP as outlined in DoD Manual 500.52-M, Environmental Restoration Program Manual.

The DoD established the IRP to identify, characterize, and evaluate past disposal sites and remediate associated contamination as needed to protect human health and the environment. The IRP was initiated at CCAFS in 1984 (PES 1995b). The IRP efforts at CCAFS have been conducted in close coordination with the USEPA, the FDEP and NASA. CCAFS is not a National Priorities List (NPL) site, and the IRP sites are being evaluated and remediated under RCRA authority while meeting CERCLA regulations.

The environmental status of each launch complex is constantly changing as remedial activities and associated projects occur. The launch complexes go through a series of processes ranging from solid waste management unit (SWMU) identification through No Further Action.

A SWMU can be defined as any discernible unit where solid wastes have been placed at any time. A RCRA Facility Assessment identifies releases or migration of contaminants from a SWMU. Confirmation Sampling (CS) can then be performed to gather sufficient data to confirm the presence or absence of contamination from the SWMU. A RCRA Facility Investigation (RFI) involves evaluating the nature and extent of the releases of hazardous wastes and hazardous constituents. During an RFI, it may be determined that a Corrective Measures Study (CMS) is necessary to evaluate remedial alternatives and provide recommendations for the SWMU. Based on the results of the CMS, Corrective Measures Implementation (CMI) is initiated to perform the appropriate remedial design. Long Term Monitoring (LTM) is conducted at SWMUs when remediation is not immediately required, as well as after remediation has been implemented, to monitor the contaminant levels and any evidence of natural attenuation. A No Further Action decision can be obtained at any time during the process if it has been determined that no release has occurred or that the release does not pose an unacceptable risk to human health or the environment. If a no further action decision is made based on the industrial setting of the SWMU, a Land Use Control Implementation Plan (LUCIP) may be prepared outlining the processes in place to protect human health and the environment while the land use remains industrial (URS 2002). Listed in the paragraphs below is a brief history of the remedial activities at each proposed SLC (current as of March 2005).

3.7.3.1 Preferred Alternative (Proposed Action)

SLC 40 (SWMU C046) The prior Titan Launch Vehicles utilized at this launch complex were liquid propellant fuels and oxidizers, including hydrazine, nitrogen tetroxide, RP-1 and LOX. Solvents were also used to flush rocket engine components. These and other hazardous materials were stored and used at various locations around SLC 40. During launch operations, thousands of gallons of water were used to suppress vibrations and for cooling purposes. These “deluge” waters were collected in a concrete basin below the launch pad before being released to the environment (CEM 2001).

Known site contaminants above residential criteria at SLC 40 are PCBs, chromium and lead in the soil. There are no known contaminants in the groundwater.

Investigation of potential contamination impacts from past activities on CCAFS began with a Cape-wide screening program conducted by the Air Force in 1993. Potential effects were identified for the SLC 40 sandblast area. A RFI was performed at the facility in 1998 through 1999. A risk assessment was

conducted to human and ecological receptors (USAF 2005).

Outside the perimeter fence around the SLC 40 launch pad, but still within the complex grounds, is a corrosion control area used for sandblasting and painting equipment and structural components, both historically and currently. PCBs were present in the soils there, as were certain heavy metals including chromium and lead. The apparent source of PCBs and metals is paint used in past operations, which has been transported to the soils by sandblasting, weathering and wear. Personnel no longer utilize such paints at the facility.

The SMARF was constructed in 1991. Prior to that there was a pond which had been designed as an emergency release retention pond for a propellant tank car storage area. Since it may have contained hazardous waste or petroleum products it was designated as SWMU 098. The pond was removed in 1991 and soil and groundwater samples determined that while some metals, polychlorinated biphenyls (PCBs) were detected, they were not considered contaminants of potential concern. (USAF 45th SW, 2005)

The SLC 40 sandblast area PCB removal action was performed in July and August 2000 to industrial levels outside the fence. (CEM 2001). Soil remediation activities inside the fence have occurred and were completed under the Legacy Resource Management Program as part of the deactivation of the launch complex. That sand blast area is currently listed as inactive.

The current recommendation is to initiate a Long Term Monitoring (LTM) plan for groundwater, plan a soil removal, initiate land use controls and develop a LUCIP (USAF 2005). No contaminants have been detected in groundwater at concentrations at SLC 40 that pose a risk to human health or the environment (USAF 2005). The PCB impacted soils were removed in the spring of 2007 (USAF 2007).

3.7.3.2 Alternative 1 – SLCs 36A and 36B

SLC 36 (SWMU C050) As an active launch complex for the Atlas Centaur Missile Program, work activities for launches and the support of launches typically include the handling and use of hazardous materials and the production of waste. The production of waste includes the former practice of flushing the rocket engine with TCE and the eventual release of the wash fluids into drainage swales and adjacent wetlands. Significant VOC concentrations of TCE breakdown products (dichloroethene [DCE] and vinyl chloride) were found in the groundwater during historical sampling. Historical soil investigations at SLC 36 showed that PCBs are the only significant chemicals of concern in the surface soils above residential criteria. The Groundwater contains VOCs, cis-and trans-1,2-dichloroethene above residential criteria (USAF 2005).

An RFI was conducted at SLC 36 from 1996 through 1998 to characterize the nature and extent of contamination and was approved in May 1999. Environmental media that were sampled and analyzed during the RFI included a HHRA and an ERA. No unacceptable risks to ecological receptors were identified (USAF 2005).

PCB contamination was identified during the soil investigation in numerous locations across both launch pads and appears to be attributable to the past use of paints and coating materials containing PCBs in their matrix. In addition, hydraulic fluids associated with launch equipment may have contained PCBs and may have been released during launch activities.

A CMS was completed in March 2000 and approved by the USEPA in April 2000. The CMS recommendations included groundwater LTM for VOCs, specifically the degradation products of TCE, cis- and trans-1,2-dichloroethene, and vinyl chloride (USAF 2002). Natural attenuation is not occurring at a fast enough rate, therefore, the Air Force is looking into other methods to speed up the groundwater cleanup.

3.7.3.3 Alternative 2 - SLC 47

There are no remedial investigations currently occurring in the proposed location for the preferred alternative 2 new SLC. SLC 37 (SWMU C056), which lies south of the proposed SLC location, is entering into the CMD phase.

3.7.4 Pollution Prevention

The Pollution Prevention Management Action Plan (P2 MAP) satisfies requirements of the Pollution Prevention Act of 1990. The PPPG also complies with requirements in DoD Directive 4210.15, AFI 32-7080, and the U. S. Air Force Installation PPPG. The PPPG establishes the overall strategy, delineates responsibilities, and specifies objectives for reducing pollution of the ground, air, surface water, and groundwater (USAF, 1998). The 45 SW Environmental Compliance Office has established P2 and Green Procurement Program (GPP) Working Groups to review all aspects of the Air Force Pollution Prevention Program and to identify areas for additional pollution prevention activities.

KSC has established a Pollution Prevention Working Group (PPWG) to review all aspects of the KSC Pollution Prevention Program and to identify areas for additional pollution prevention activities. The team consists of KSC and contractor personnel. The NASA Acquisition Pollution Prevention Office assists KSC and other NASA centers in identifying, validating, and implementing less hazardous materials and processes.

Pollution prevention activities would be conducted in accordance with the established base-wide Pollution Prevention Plan for CCAFS. Any fuel spills or leaks would be corrected utilizing established procedures within the Emergency Response and Spill Prevention Plan for CCAFS

3.8 WATER RESOURCES

Water resources include groundwater and surface water, and their physical, chemical, and biological characteristics. This section addresses the physical and chemical factors that influence water quality and surface runoff. The Region of Influence (ROI) for groundwater includes the local aquifers that are directly or indirectly used by CCAFS. The ROI for surface water is the drainage system/watershed in which the station is located. Groundwater contamination is discussed in Section 3.7.3.

The federal Clean Water Act (CWA) established the basic structure for regulating discharges of pollutants into the waters of the U.S. and is the primary law regulating water pollution. It gave USEPA the authority to implement pollution control programs such as setting wastewater standards for industry. The CWA also continued to set requirements for water quality standards for all contaminants in surface waters and made it unlawful for any person to discharge any pollutant from a point source into navigable waters, unless a permit was obtained under its provisions. The Florida Department of Environmental Protection (FDEP) issues NPDES industrial storm water permits, storm water construction permits, and wastewater construction permits. The St. Johns River Water Management District (SJRWMD) issues the applicable Environmental Resource Permits (ERP).

Treated water discharged to surface water or to the ocean is subject to the requirements of the NPDES permit, which ensures that the water discharged meets water quality standards at the point of discharge. In addition, projects disturbing one acre or more are subject to NPDES permit requirements for storm water discharges during construction. This permit requires the preparation of a Storm Water Pollution Prevention Plan. Section 319 of the CWA requires states to assess nonpoint

water pollution problems and to develop nonpoint source pollution management programs with control to improve water quality. Section 404 of the CWA requires a permit from the USACE in order to locate a structure, excavate, or discharge dredged or fill material into Waters of the United States.

3.8.1 Surface Water

CCAFS is within the Florida Middle East Coast Basin and situated on a barrier island that separates the Banana River from the Atlantic Ocean. This basin contains three major bodies of water: the Banana River to the immediate west, Mosquito Lagoon to the north, and the Indian River to the west, separated from the Banana River by Merritt Island. All three water bodies are estuarine lagoons, with circulation provided mainly by wind-induced currents (ET 1998). The storm water management system at CCAFS is multibasinal. Because of the relatively flat topography, many man-made canals and ditches have been constructed to facilitate surface water drainage around developed areas (HSW 1999).

Several water bodies in the Middle East Coast Basin have been designated as Outstanding Florida Water (OFW) in FAC 62-3, including most of Mosquito Lagoon of the Banana River, Indian River Aquatic Preserve, Banana River State Aquatic Preserve, Pelican Island National Wildlife Refuge, and Canaveral National Seashore. These water bodies are afforded the highest level of protection, and any compromise of ambient water is prohibited.

The Indian River Lagoon System has also been designated an Estuary of National Significance by the USEPA. Estuaries of national significance are identified to balance conflicting uses of the nation's estuaries while restoring or maintaining their natural character. The Banana River has been designated a Class III surface water, as described by the CWA. Class III standards are intended to maintain a level of water quality suitable for recreation and the production of fish and wildlife communities. There are no wild and scenic rivers located on or near CCAFS.

SLC 40 and the SMARF area including the road-way between the two are completely surrounded by low-lying marshlands and sloughs. Wetlands that are associated with the Banana River are located within 1,000 ft to the west and the Atlantic Ocean is within 1,300 ft to the east. On site, surface water drains by overland flow to the four man-made low-lying percolation areas and drainage swales. The on-site swales consist primarily of mowed and maintained grass. Surface water recharges the groundwater system through infiltration when water collects in the low-lying areas of the site. There are no permanent surface water bodies within the fenced area of the site.

3.8.2 Ground Water

The SJRWMD issues the ERP, which includes storm water and wetlands management, in coordination with the FDEP and USACE. The USEPA is responsible for management of the NPDES permit process and wastewater discharges.

The surficial and the Floridan aquifer systems underlie CCAFS. The surficial aquifer system, which comprises generally sand and marl, is under unconfined conditions and is approximately 70 feet thick. The water table in the aquifer is generally a few feet below the ground surface (ET 1998). The surficial aquifer is recharged by infiltration of precipitation through the thin vadose zone. Assuming negligible runoff, the amount of recharge is approximately equal to the amount of precipitation minus the amount returned to the atmosphere through evaporation and transpiration (OBG 2001b). Groundwater in the surficial aquifer at CCAFS generally flows to the west, except along the extreme eastern coast of the peninsula.

A confining unit composed of clays, sands and limestone separates the surficial aquifer from the underlying Floridan aquifer. The confining unit is generally 18 to 120 feet thick. The relatively low hydraulic conductivity of the confining unit restricts the vertical exchange of water between the surficial aquifer and the confined Floridan aquifer. The Floridan aquifer is the primary source of potable water in Central Florida and is composed of several carbonate units with highly permeable zones. The top of the first carbonate unit occurs at a depth of approximately 180 feet below ground surface, and the carbonate units extend to a depth of several hundred feet. Groundwater in the Floridan aquifer at CCAFS is highly mineralized.

The surficial aquifer at SLC 40 consists of clastic sediments that contain groundwater primarily under unconfined conditions. Groundwater occurs at depths ranging from about 3.2 to 18.0 ft below land surface (bls). Shallow groundwater movement across the site is west and south under a hydraulic gradient that ranges from 0.001 to 0.003 ft/ft.

3.9 GEOLOGY AND SOILS

3.9.1 Geology

The geology underlying CCAFS can be generally defined by four stratigraphic units: the surficial sands, the Caloosahatchee Marl, the Hawthorn Formation, and the limestone formations of the Floridan aquifer. The surficial sands immediately underlying the surface are marine deposits that typically extend to depths of approximately 10 to 30 feet below the surface. The Caloosahatchee Marl underlies the surficial sands and consists of sandy shell marl that extends to a depth of 70 feet below the surface. The Hawthorn Formation, which consists of sandy limestone and clays, underlies the Caloosahatchee Marl and is the regional confining unit for the Floridan aquifer. This formation is generally 80 to 120 feet thick, typically extending to a depth of approximately 180 feet below the surface. Beneath the Hawthorn Formation lie the limestone formations of the Floridan aquifer, which extend several thousand feet below the surface at CCAFS (USAF 1991).

Bedrock at CCAFS ranges from a hard to dense limestone that is a principal part of one of the major Florida Artesian Aquifers, located 75 to 300 feet below the surface. It is overlain by sandy limestone, calcareous clay with fragments of shells, coquinoïd limestone and unconsolidated, well-graded quartz sand. The surface is a mixture of permeable sand and shell materials. There are no rock outcrops on the installation (ESC 2001).

SLC 40 and SMARF building geology consists of recent, unconsolidated deposits that became finer grained with increasing depth from the surface. The geology consists of fine to coarse sand with some shell fragments from 0-15 ft bls. Split-spoon samples indicate that sands generally show a decrease in grain size from the land surface. Silt and clay occur as distinct lenses within this interval and range from less than an inch in thickness to layers of six inches or greater. These lenses or layers occur sporadically within this interval and are difficult to correlate from one location to another.

SLC 47 is approximately 1.5 miles south of SLC 40, and SLC 36 is approximately 7 miles south of SLC 40. The geological subsurfaces for those complexes are very similar to that of SLC 40.

3.9.2 Topography and Soils

The CCAFS topography consists of a series of relic dune ridges formed by wind and wave action, indicating that gradual beach deposits occurred throughout time. The higher naturally occurring

elevations occur along the eastern portion of CCAFS, with a gentle slope to lower elevations toward the marshlands along the Banana River. Land surfaces are level to gently sloping along the SLCs with elevations that range from sea level to 15 feet above mean sea level (MSL) (ESC 2001).

The soil survey of Brevard County, Florida, 1974, identifies eleven different soil types within CCAFS, with the three most prominent soils comprising the Canaveral-Palm Beach-Welaka association. It is about 37 percent Canaveral soils, 17 percent Palm Beach soils, nine percent Welaka soils, and 37 percent soils of minor extent. This association is made up of nearly level and gently sloping ridges interspersed with narrow wet sloughs that generally parallel the ridges and extends the entire length of the county along the coast near the Atlantic Ocean. The most prevalent type of soil is Canaveral Peninsula.

Canaveral soils are on moderately low ridges and consist of a mixture of light-colored quartz sand grains and multicolored shell fragments. The major soils in this area are moderately well drained to excessively drained, and sandy throughout. The soils are exceptionally dry, even though the water table is often near the surface during rainy periods. The soils are not suited to cultivate crops or improved pasture and are poorly suited for citrus groves (ET 1998).

Soils at SLC 40 and the SMARF and SLC 36 and 47 are primarily of the Palm Beach and Canaveral soils, but are excessively drained. They occur on higher ridges, have a lower water table and are commonly in areas between Cape Canaveral and Melbourne Beach. Welaka soils are well-drained sandy soils and have a light-colored subsurface layer and yellowish subsoil. The subsoil extends to a depth of 40 to 60 inches. Below this is a mixture of quartz sand and shell fragments. Minor in this association are the Myakka, Pomello, and Parkwood soils, Coastal beaches and poorly drained soils in sloughs. The major soils in this association are droughty, even though in some areas the water table is near the surface during rainy periods (ESC 2001). Other soil classifications found at SLC 40 and the SMARF area are Urban Land and Coastal beaches. The majority of the complex is considered a developed area. A discussion of soils at SCL 40 which have been impacted with various contaminants from past activities can be found in Section 3.7.3 above.

3.10 TRANSPORTATION

3.10.1 General Area Network Description

This section addresses the transportation network that provides access to CCAFS and the Launch complexes. The ROI analysis focuses on the roadways and railroads on CCAFS reaching SCL 40, 36, and 47, and immediately surrounding the installation.

3.10.1.1 Roadways

The evaluation of the existing roadway conditions focuses on capacity, which reflects the ability of the network to serve the traffic demand and volume, usually expressed as the maximum service volume at a given level of service (LOS), or the amount of traffic the roadway will carry before the level of congestion becomes unacceptable. The capacity of a roadway depends on a number of physical characteristics, but is generally determined based on area type, roadway type and number of travel lanes. The performance of a roadway segment is generally expressed in terms of LOS. The LOS scale ranges from A to F, with each level being generally defined by a range of volume-to-capacity (V/C) ratios. LOS A, B, and C are considered good operating conditions under which minor to tolerable delays are experienced by motorists. LOS D represents a condition with some moderate to heavy level of congestion and delay. LOS E reflects a roadway at maximum capacity, with heavy

levels of congestion and delay, and LOS F represents failure of the roadway to handle the traffic volumes – with resultant major congestion, gridlock conditions and major delay. The Florida Department of Transportation (FDOT), using methodology based on the Highway Capacity Manual, has developed LOS tables for Florida roadways based on generalized conditions for the state of Florida. These LOS tables identify the maximum volumes associated with the various levels of service for various roadway types, differentiating by area type, roadway type, signal spacing and number of travel lanes. Table 3.10-1 presents the general descriptions of the different LOS designations.

**Table 3.10-1
Road Transportation Levels of Service**

LOS	Description
A	Free flow with users unaffected by presence of other roadway users
B	Stable flow, but presence of the users in traffic stream becomes noticeable
C	Stable flow, but operation of single users becomes affected by interactions with others in traffic stream
D	High density, but stable flow; speed and freedom of movement are severely restricted; poor level of comfort and convenience
E	Unstable flow; operating conditions at capacity with reduced speeds, maneuvering difficulty, and extremely poor levels of comfort and convenience
F	Forced breakdown flow with traffic demand exceeding capacity; unstable stop-and-go traffic

Source: Compiled from Transportation Research Board, 1994.

Existing and future traffic volumes are typically reported as the number of vehicular movements averaged over an annual daily period, Average Annual Daily Traffic (AADT). The Peak-Hour Volume (PHV) of traffic is defined as the highest volume of traffic occurring within a single hour of a 24-hour period. Peak hour volumes typically occur either between 7:00 am and 9:00 am and 4:00 pm and 6:00 pm. Accordingly, these are the typical periods of the day when congestion is expected to occur.

Traffic data and physical roadway characteristics were obtained from data provided by state and local highway departments. The capacity of each of the roadway segments studied was determined based upon the roadway classifications reported from the local and state governments and the Florida Department of Transportation Quality/Level of Service Manual (1998 and 2002).

Regional Access - The CCAFS area can be accessed from Daytona Beach and other locations via U.S. Highway (US) 1 or Interstate 95; Orlando lies approximately 50 miles to the west on State Route (SR) 528; and Miami is approximately 187 miles to the south on US 1 or Interstate 95.

Local Access - The majority of the employees and other related support services providers for CCAFS reside within the unincorporated areas of Brevard County and in the cities of Cape Canaveral, Cocoa, Cocoa Beach, and Rockledge, which are all within 14 miles of the station (ET 1998). The key roads providing access to CCAFS from the local communities include SR A1A, SR 520, SR 528, SR 401, SR 3, and SR 405. The NASA Causeway (SR 405), Beach Road, and SR 528 connect CCAFS with KSC, the inner barrier islands and the mainland.

Southern access into CCAFS occurs through Gate 1. Gate 1 is accessed by SR 401 via SR A1A, SR 520, and SR 528.

- SR 401 is a 5-lane road that narrows to a 4-lane divided road as it approaches Gate 1 where it becomes Samuel C. Phillips Parkway.
- SR A1A is a north-south, 4-lane divided highway to the south of CCAFS that connects SR 401 (and Gate 1) with the cities of Cape Canaveral and Cocoa Beach and PAFB.
- SR 520 is a 4-lane/6-lane, east-west urban roadway that crosses the Banana River and the Indian River Lagoon and connects the cities of Cocoa and Rockledge to Merritt Island, as well as connecting SR A1A and Interstate 95.
- SR 528 is a 4-lane, limited-access toll road that connects the Orlando urban area to the coast. It intersects the southern portion of CCAFS from the west, connecting the mainland to Merritt Island and the barrier islands. The road is used extensively by KSC personnel. SR 528 and SR A1A merge into SR 401 just south of CCAFS.

Western access onto CCAFS is provided by SR 3 and SR 405.

- SR 3 is a north-south highway that bisects KSC. It becomes Kennedy Parkway on KSC property and provides access to Gate 2, located on the south side of KSC.
- SR 405 is a 4-lane road providing access to CCAFS from the west. It turns into the NASA Causeway after entering KSC at Gate 3, just before crossing the Indian River Lagoon. After continuing through KSC, SR 405 crosses the Banana River, entering CCAFS and intersecting SR 401 (Samuel Phillips Parkway).

From the north, CCAFS can be accessed through Gate 4 and Gate 6 at KSC.

- SR 3 provides access to Gate 4 from the north.
- Beach Road provides access to Gate 4 and Gate 6 from the west. Beach Road becomes SR 401 as it approaches CCAFS and subsequently turns into Samuel C. Phillips Parkway.

Existing conditions for key roads on/near CCAFS are presented in Table 3.10-2 below.

Table 3.10 - 2
Peak-Hour Traffic Volumes and LOS on Key Roads Serving CCAFS

Roadway	Segment	No. of Lanes	Maximum Capacity	2002 PHV**	LOS
SR A1A	From SR 401 to North Atlantic	4	3,260	2,590	C
SR 528	From SR 3 to SR 401	4	6,900	3,500	C
NASA Causeway***	From US 1 to Samuel C. Phillips Parkway	4	3,390	2,450	B
Samuel C. Phillips Pkwy/Hangar Road***	Between Gate 1 and SR 401 (Gate 6)	4	3,260	1,140	B

* Taken from the FDOT Quality/LOS Handbook, based on characteristics provided by Brevard County and Titusville.

** Calculated from the Brevard County MPO Traffic Counts 2003/2003 converted by the K100 contained on the FDOT 2002 Traffic Count CD.

*** From the Florida Space Authority Master Transportation Plan, 2002.

3.10.2 On-Site Transportation

3.10.2.1 Roadways

The major on-site roadway on CCAFS is Samuel C. Phillips Parkway, a 4-lane divided highway that accommodates most of the north-south traffic. At its intersection with Skid Strip Road, Samuel C. Phillips Parkway becomes a one-way northbound arterial, with Hangar Road serving as the southbound arterial. East-west roadways, including Pier Road, Lighthouse road, Flight Control Road, and Central Control Road provide access from Samuel C. Phillips Parkway to the launch site locations. ICBM Road and Control Tower Road run adjacent to the launch complexes and provide additional internal roadway access. To the north and south of CCAFS, Samuel C. Phillips Parkway becomes SR 401.

SLC 40 is generally accessible via Samuel C Phillips Parkway; however it is also accessible via Titan Road from the south which also provides access to the SMARF. Roadway access also co-exists with rail access between SLC 40 and the SMARF.

SLC 36 (approximately 7 miles south of SLC 40) is accessible via Central Control Road, and SLC 47 (approximately 1.5 miles south of SLC 40) is also accessible via Samuel C Phillips Parkway.

3.10.2.1 Railways

The region of influence for railways includes the Florida East Coast Railway, which provides rail service to Brevard County through the cities of Titusville, Cocoa, and Melbourne. An additional railway in the integrate transfer launch area on CCAFS is accessible by the Florida East Coast Railway through KSC and Titusville. That rail line also connects to the SMARF and to SLC 40.

3.11 UTILITIES

This section addresses water supply and treatment, solid waste handling, and electrical power for CCAFS and SLC 40, SLC 36, and SLC 47 which is also the ROI.

3.11.1 Water Supply

Water for CCAFS is acquired from the City of Cocoa's municipal potable water distribution system under a long-term agreement which has a 37 million gallon per day (MGD) capacity. The City's contract is with the U.S. Government and includes KSC, CCAFS and Patrick Air Force Base (PAFB). A total of 6.5 million gallons per day (MGD) is allocated for all three facilities. Historically, total consumption of water from the city for all three facilities has averaged 3.7 MGD. CCAFS, in turn, recovers a portion of the cost of water under its contracts with commercial contractors operating on CCAFS.

Water is utilized at CCAFS for both potable and non-potable purposes. Non-potable use includes fire protection, limited irrigation and launch-related consumption. Launch pad use of non-potable water includes noise abatement, cooling and shock wave attenuation associated with the deluge system. CCAFS recently upgraded the distribution facilities to improve water quality in the potable distribution system. Pump house number 7 supplies non-potable deluge water to SLC 40 and SLC 41. The design capacity of supply water to SLC 40 is up to 800,000 gallons per launch for deluge purposes. The pump house is able to supply 40,000 gallons per minute.

Currently, the City of Cocoa utilizes groundwater from the Floridan aquifer at its wellfield in eastern Orange County. The City owns and operates a water treatment facility at the same location. For planning purposes, treatment plant capacity is considered to be either the plant's physical treatment capacity or its permitted withdrawal capacity, whichever is smaller. Generally, the treatment capacity exceeds the withdrawal capacity of a given facility. Treatment capacities are based upon mechanical equipment actually installed, which typically provides for redundant or back-up reliability.

Groundwater withdrawal amounts are limited by the City's Consumptive Use Permit (CUP), which is issued by the SJRWMD. The current capacities of Cocoa's system are:

- Treatment – 48.0 MGD (avg)
- Groundwater Withdrawal – 48.0 MGD (max)
- Surface Water Withdrawal – 19.0 MGD (max)

In 2002, the city's average daily potable water production was 27.13 million gallons (USAF 2005).

3.11.2 Solid Waste Management

General solid refuse at CCAFS is collected by a private contractor and disposed of off-site at the Brevard County Landfill, a Class I landfill located near the City of Cocoa. Class I and II landfills receive general, non-hazardous household, commercial, industrial, and agricultural wastes, subject to the restrictions of Rule 62-701.300 and 62-701.520, Florida Administrative Code (FAC). CCAFS also operates an on-site, Class III landfill that accepts construction and demolition debris and asbestos-containing material.

3.11.3 Electrical Power

Florida Power and Light provide power and lighting transmission systems for both Cape Canaveral AFS and KSC. Together, Cape Canaveral AFS and KSC have a total capacity of 216,000 kilovolt-

amperes (kVA). The Air Force owns the distribution system. Transmission lines enter the installation at three locations. The capacity of the three substations is 55 megawatts (MW), and they are capable of providing 1,320 MWH/day. There are also 170 substations on Cape Canaveral AFS that convert the voltage to user voltages.

3.12 HEALTH AND SAFETY

The areas in and around CCAFS that could be affected by payload processing, transport, and launch are the subject of health and safety concerns. Range safety organizations review, approves, monitors, and imposes safety holds, when necessary, on all pre-launch and launch operations in accordance with AFSPC 91-710. The objective of the range safety program is to ensure that the general public, launch area personnel, foreign land masses, and launch area resources are provided an acceptable level of safety, and that all aspects of prelaunch and launch operations adhere to public laws.

3.12.1 Regional Safety

CCAFS, KSC, the City of Cape Canaveral, and Brevard County have a mutual-aid agreement in the event of an on- or off-station emergency. During launch activities, CCAFS maintains communication with KSC, Brevard County Emergency Management, the Florida Marine Patrol, the U.S. Coast Guard, and the state warning point, Division of Emergency Management. Range Safety monitors launch surveillance areas to ensure that risk to people, aircraft, and surface vessels is within acceptable limits. Control areas and airspace are closed to the public as required (USAF, 1998).

3.12.2 On-Station Safety

Launches are not allowed to proceed if an undue hazard exists for persons and property due to potential dispersion of hazardous materials or propagation of blast overpressure. The 45 SW has prepared detailed procedures to be used to control toxic gas hazards. Atmospheric dispersion computer models are run to predict toxic hazard corridors (THCs) for both nominal and aborted launches, as well as spills or releases of toxic materials from storage tanks or that occur during loading or unloading of tanks. Range Safety uses the THCs to reduce the risk of exposure of CCAFS and KSC personnel and the general public to toxic materials, including toxic gases.

JHB-2000 revision A (March 2002) is the Consolidated Comprehensive Emergency Management Plan (CCEMP) as described in Section 3.7.1. The 45th SW OPLAN 32-3 addresses emergency response to hazardous material incidents. For a NASA launch, the Launch Disaster Control Group (LDCG) is a joint NASA/USAF emergency response team formed prior to each launch and situated at a fallback location. For a NASA launch, the Disaster Control Group (DCG) is a joint NASA/USAF emergency response team that is activated for nonlaunch-related disasters at CCAFS (USAF, 1998). Other applicable regulations and compliance documents are listed in Section 2.1.1.6 under Safety Systems.

In addition to the environmental review and determination, the project proponents for the Falcon Launch Vehicle Program must complete a safety review and approval. More discussion is provided below on the specific safety requirements for construction and operation of a space launch program at CCAFS.

3.12.2.1 Range Safety Procedures

Impact debris corridors are established for the Falcon 1 and Falcon 9 Launch Vehicle Program, on a mission (launch) basis as part of the program's safety review using the results of a debris analysis.

Impact debris corridors would be established off the Brevard County, Florida coast over the Atlantic ocean to meet security requirements and reduce the hazard to persons and property during a launch-related activity. Impact debris corridors are established through the designation of debris impact areas for each specific launch within the PFDP document.

The 45 SW Flight Analysis notifies the 1st Range Squadron of areas that are hazardous to aircraft (i.e., impact debris corridors) for all normally jettisoned and impacting stages by 30 working days prior to launch. The 1st Range Squadron notifies the FAA so that the appropriate Altitude Reservation (ALTRV) or Notice to Airmen can be disseminated. Restricted and Warning Areas would be active and controlled according to AFSPCMAN 91-710, Range Safety Requirements, Safety Operating Instructions, 45 SW regulations, and FAA directives and regulations. Control of air traffic in FAA-designated areas around the launch head would be maintained and coordinated between the Military Radar Unit and FAA to ensure that non-participating aircraft are not endangered by launches. The Military Radar Unit would restrict aircraft movement in Restricted Airspace and Warning Areas beginning 15 minutes prior to the scheduled launch time and until the launch is complete.

Zone closures are announced daily over various radio frequencies and posted in harbors along the coast. The 45 SW Flight Analysis notifies the 1st Range Squadron of areas that are hazardous to shipping for all normally jettisoned and impacting stages by 30 working days prior to launch. This information is published weekly in the U.S. Coast Guard Broadcast to Mariners. Broadcasts by U.S. Coast Guard Cape Canaveral provide the latest available hazard information to offshore surface vessels. CCAFS in conjunction with Patrick AFB would assume control and could set up a national defense area if protected material were involved in any launch vehicle accident. In the event of a launch vehicle impacting areas outside CCAFS, the On-Scene Disaster Control Group from CCAFS would respond to the accident upon request of the county. County agencies would be requested to help in the evacuation and possible fire control for such an incident. Military personnel would assume responsibility for disaster control in the immediate impact area.

3.12.2.2 Fire Protection System Requirements

Fire protection, alarm, and fire suppression systems must be provided for all fuel holding areas and support facilities. Flame detectors in the fuel holding areas would activate both the area deluge water system and alarms to the Air Force Fire Department.

3.12.2.3 Mission/Vehicle Reliability Requirements

Mission reliability is measured from launch commit and is defined as the probability of successfully placing the payload into its delivery orbit with the required accuracy, and then executing a collision avoidance maneuver. Specific standards for mission/vehicle reliability are contained in AFSPCMAN 91-710, Range Safety Requirements and must be adhered to.

3.12.2.4 Quantity Distance Criteria Requirements

Explosive safety quantity-distance criteria are used to establish safe distances from launch complexes and associated support facilities to non-related facilities and roadways. DoD and Air Force Explosive Safety Standards establish these regulations. The criteria utilize the trinitrotoluene, also called TNT, explosive equivalent of propellant, to determine safe distances from space launch operations or processing and holding areas. SLC-40 was originally sited to meet these criteria under the Titan IV program. Per AFSPCMAN 91-710, all facilities including launch complexes, used to store, handle, or process ordnance items or propellants shall be properly sited and approved in accordance with DoD quantity distance criteria and explosives safety standards as specified in DoD 6055.9-STD and implemented in AFMAN 91-201.

3.12.2.5 Hazardous Materials Transportation Safety Requirements

Hazardous materials such as propellant, ordnance, chemicals, and other payload components must be transported to CCAFS in accordance with Department of Transportation regulations for interstate shipment of hazardous substances (Title 49 CFR 100-199). Hazardous materials such as liquid rocket propellant must be transported in specially designed containers to reduce the potential of a mishap should an accident occur (USAF, 1998). For some hazardous materials, each state may have its own required transportation routes, time of shipments, and permits. To date, no major accidents involving the shipment of hazardous materials associated with launch vehicles at CCAFS have occurred.

3.12.2.6 Toxic Release Contingency Plan Requirements

A Toxic Hazard Assessment for the Falcon Launch Vehicle Program would be required to determine program-specific launch vehicle, payload, ground-support equipment, and facility toxic materials use; the existing Toxic Release Contingency Plan for CCAFS may also have to be updated according to the results of the assessment. Toxic Hazard Assessments are also conducted to develop and control Toxic Hazard Zones for each launch. Toxic Hazard Assessments provide the appropriate safety clear areas for the storage, handling, and transfer of propellants; they also provide for protection of workers and the general public during vehicle processing and launch operations. The Toxic Hazard Assessments must be completed and the Toxic Release Contingency Plan must be updated, if necessary, prior to loading or storing the program's toxic materials.

At SLC-40, an Air Force-developed suite of dispersion models ran by Eastern Range Safety Risk Analysis personnel would be used for both normal and aborted launch scenarios prior to launch. If the model predicted that populated areas lay within the toxic hazard corridor (THC), the launch would be delayed until more favorable meteorological conditions existed. De-tanking or other procedures to be followed in the event of a launch delay or cancellation would be established and would generally be in accordance with procedures used for current vehicle systems.

3.12.2.7 Exposure Criteria Requirements

The Headquarters Air Force Space Command Surgeon General's Office (HQ AFSPC/SG) has either endorsed or recommended exposure criteria for some of the current liquid rocket propellants and their combustion byproducts (including RP-1). Health hazards may be created from propellant spills or from the passage of launch plumes/launch abort clouds. The chemicals chosen for these criteria are those estimated to present the most significant health concerns to the public and launch facility workers. The recommended and endorsed exposure criteria are factored into the exposure prediction and risk management models and the launch commit decisions used by the Range Safety functions at CCAFS.

Currently there are no regulatory health exposure limits or public exposure criteria for vapors of hydrotreated kerosene. However, both the National Institute for Occupational Safety and Health and the National Academy of Sciences/National Research Council/Committee on Toxicology have recommended exposure limits for individuals occupationally exposed to vapors of similar substances.

3.12.2.8 Security Requirements

Security requirements for launch sites, an integral component of project safety, are contained in SWI 31-101, AFI 31-101, and DoD Manual 5220.22-M. Site security requirements would include security lighting and an intrusion detection system.

Additionally, Unified Facilities Criteria (UFC) 4-010-01 was issued on January 2007 under the authority

of DODI 2000.16, DOD Antiterrorism Standards. The guidance requires DOD components to adopt and adhere to common definitions, criteria, and minimum construction standards for buildings to mitigate vulnerabilities and terrorist threats. The 45 SW will review all constructions plans by SpaceX to ensure any new facilities at SLC 40 are designed with the UFC criteria.

Further Antiterrorism procedures will be established by SpaceX, in concert with AF guidance to also ensure any vehicle, payload, or other item entering on to CCAFS will follow existing procedures.

3.13 SOCIOECONOMICS

The influence of launch programs at CCAFS on population and employment varies widely within several counties. CCAFS generally influences eastern Brevard County, which includes several cities some of which are Melbourne, Cocoa Beach, Titusville, and Cocoa. CCAFS however also draws commuters from Orange County (Orlando) and Volusia County. Based upon the 2005 Census of Population and Housing, Brevard County had a population of 531,250 persons (U.S. Bureau of Census 2005).

The Spaceport (KSC and CCAFS) is Brevard County's major employer with a combined CCAFS/KSC work force of more than 27,000 employees (Military, civil service, other governmental, and contract employees) as of 2002. Statewide, the Space industry employs over 43,000 workers. The presence of these employers causes a chain of economic reactions throughout the local region and nearby counties. It is estimated that for each job in the space industry, another two are created within the region. This economic force generates well over \$4 billion in the Florida economy annually (Enterprise Florida).

Encouraging commercial space launch companies such as SpaceX to reuse excess launch platforms which otherwise may be demolished is a practice taking place to ensure there continues to be a positive impact on the economics of Brevard County.

3.14 ENVIRONMENTAL JUSTICE

Environmental justice is defined by the U.S. EPA as "The fair treatment and meaningful involvement of all people regardless of race, color, national origin, or income with respect to the development, implementation, and enforcement of environmental laws, regulations, and policies."

Executive Order 12898, "General Actions to Address Environmental Justice in Minority Populations and Low-Income Populations," requires all federal agencies to adopt strategies to address environmental justice concerns within the context of agency operations. Section 989.33 of AFI 32-7061, *Environmental Impact Analysis Process* requires that a project proponent comply with EO 12898 to ensure that these types of impacts are considered in EAs and other environmental documents.

The 2005 Census of Population and Housing reports numbers of minority residents are as follows: Minority populations included in the census are identified as Black or African American, American Indian and Alaskan Native, Asian, Native Hawaiian/Other Pacific Islander, Hispanic, or Other. Based upon the 2005 Census of Population and Housing, Brevard County had a population of 531,250 persons. Of this total, 94,031 persons, or 17.7 percent, were minority. Orange County had a population of 1,023,023 persons, of this total, 499,235 persons or 48.8 percent were minority. The largest segment of the minority population is Hispanic at 23.2 percent.

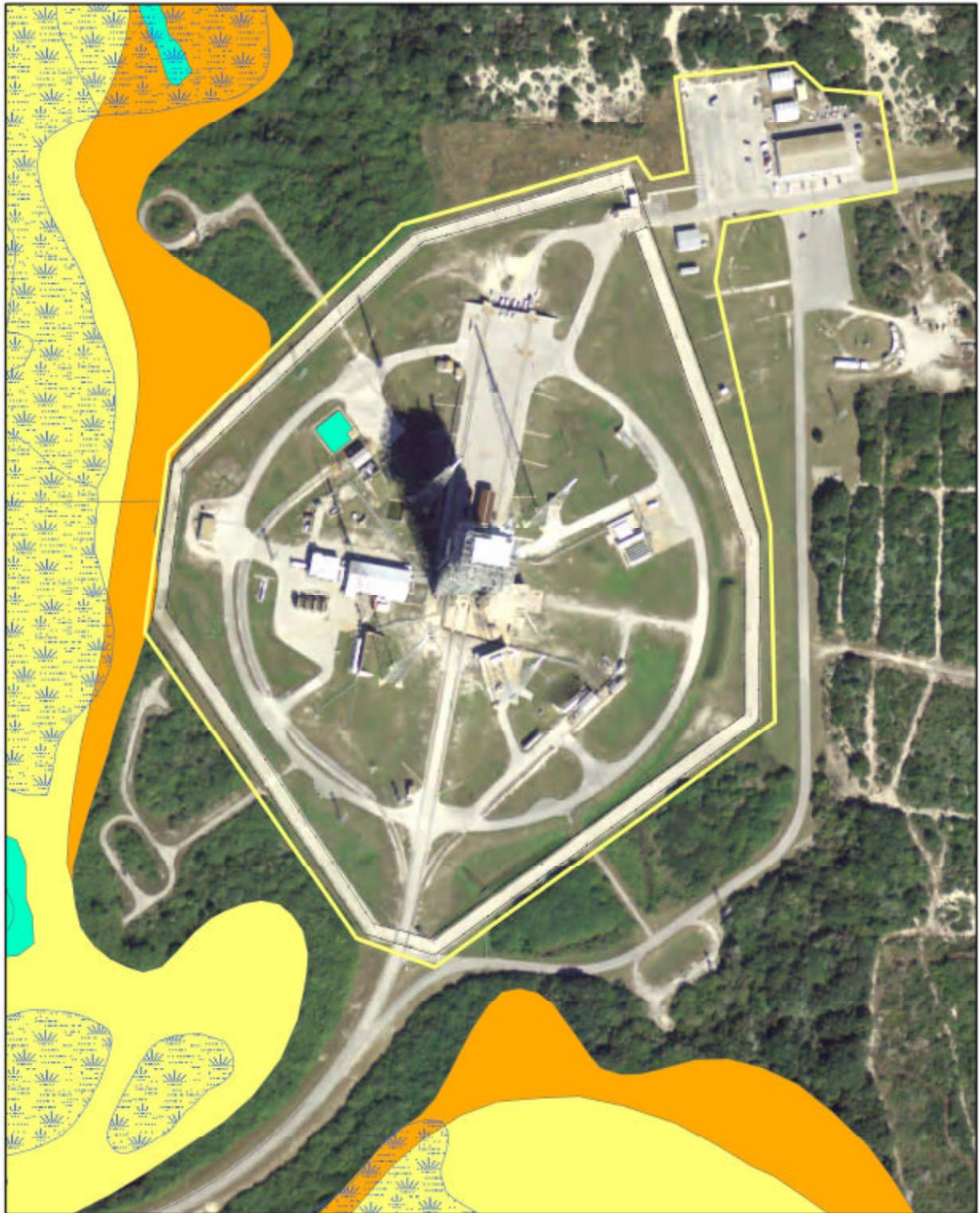

Figure 3.3-1 Wetlands and Floodplain Map - SLC 40 Site









<ul style="list-style-type: none">  Site Boundary  Fence  Surface Water 	<ul style="list-style-type: none">  Wetlands  100 Year Floodplain  500 Year Floodplain 		Cape Canaveral Air Force Station Cape Canaveral, Florida
<p>0 120 240 480 720 960</p>  Feet			



Figure 3.3-2 - Wetlands and Floodplain Map - SLC 36A Site



- Fence
- SLC Boundary

100 Year Floodplain

- Wetlands
- Surface Water

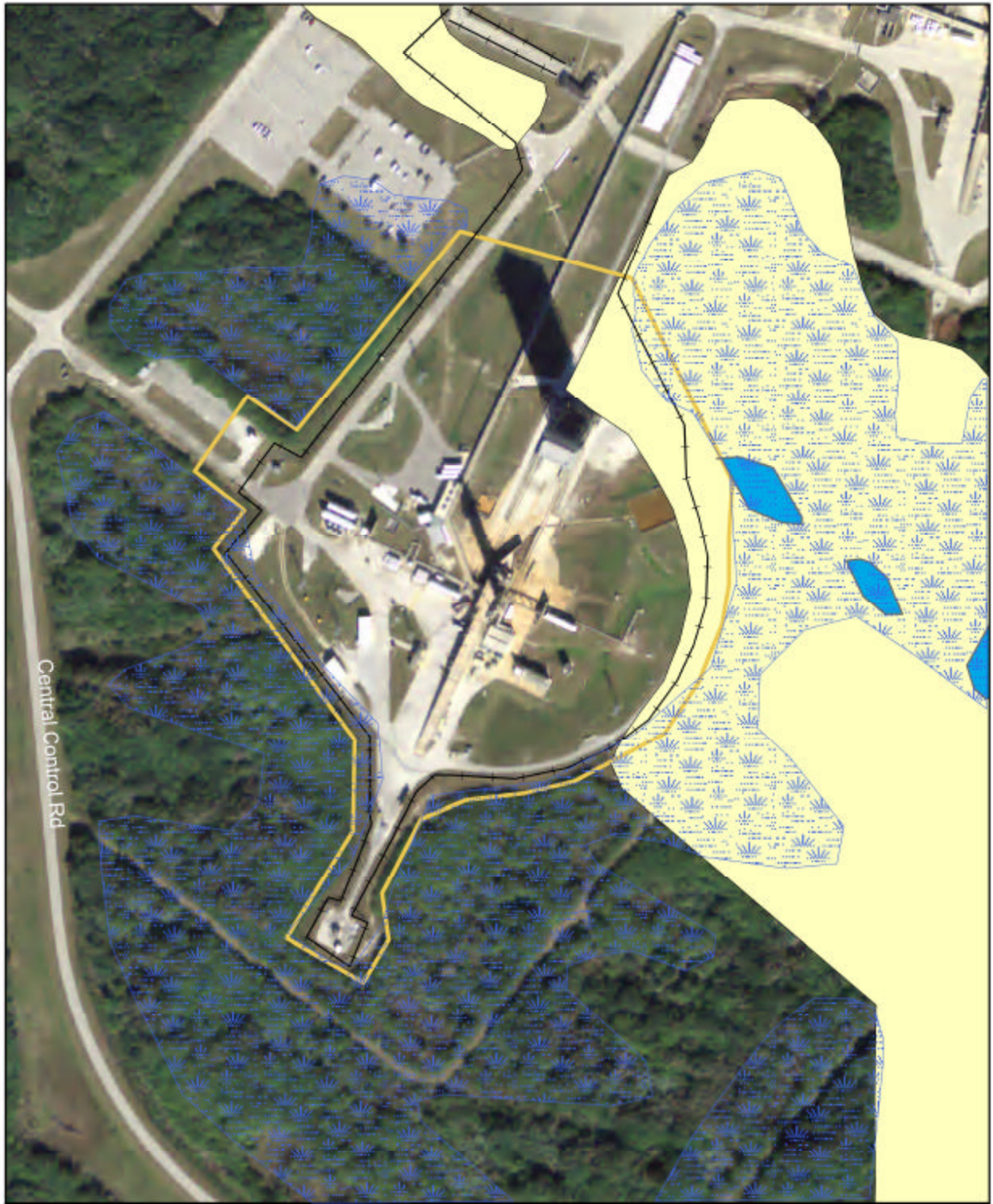
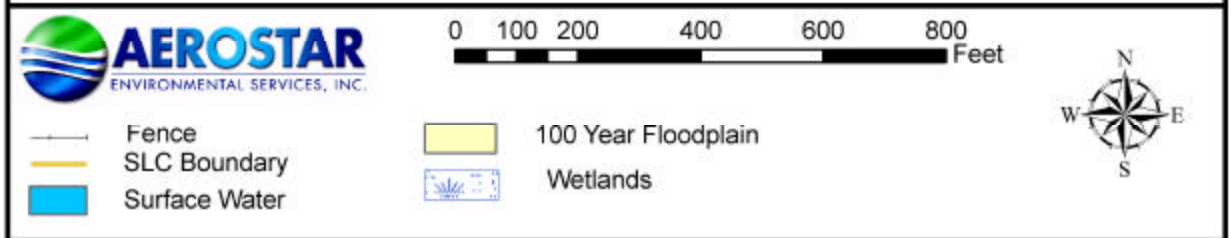

Figure 3.3-3 - Wetlands and Floodplain Map - SLC 36B Site



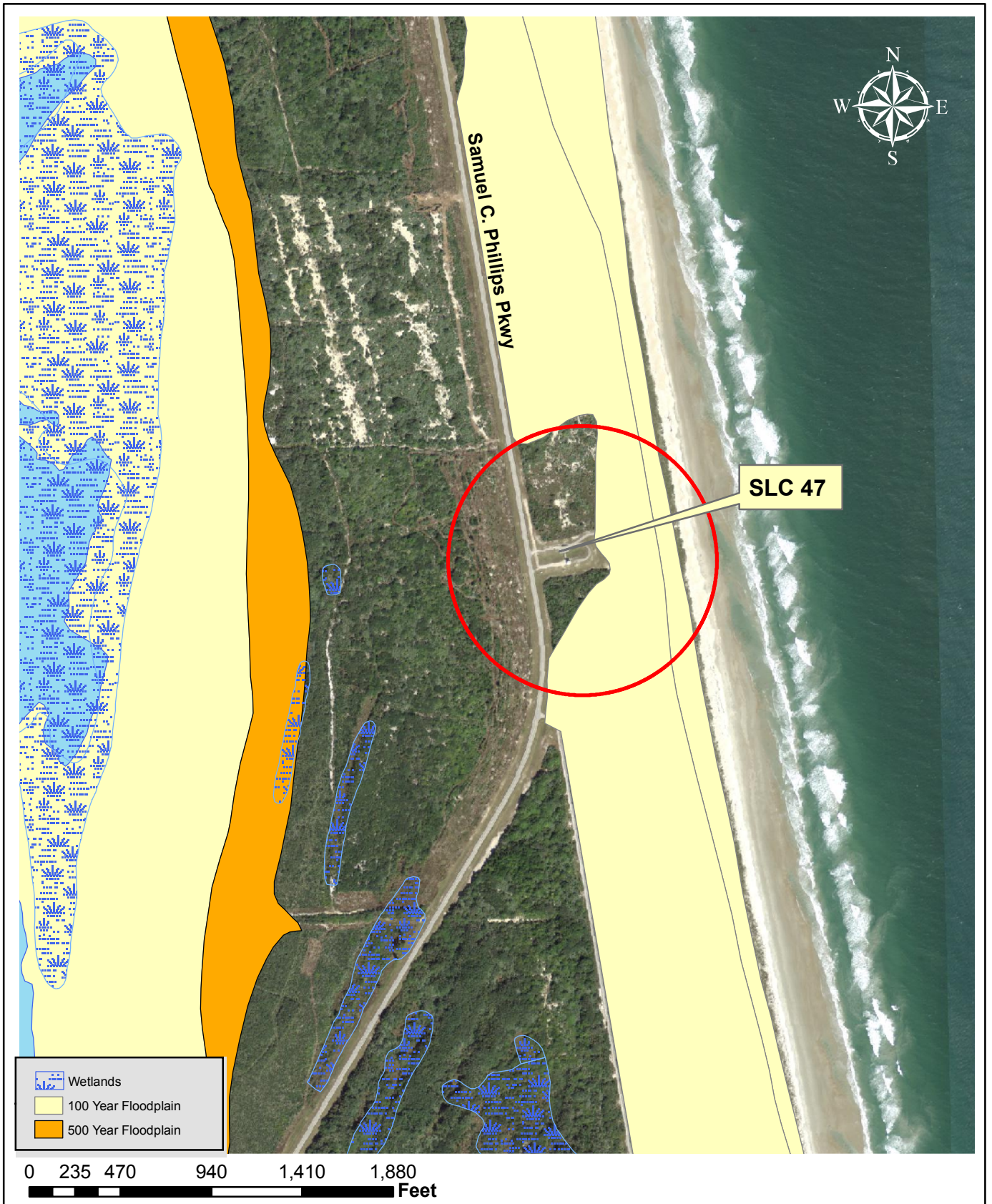

FIG 3.3-4 WETLANDS AND FLOODPLAIN SLC 47 SITE



Environmental Assessment
Space X Falcon 1 and Falcon 9
Launch Program
Cape Canaveral Air Force Station
Brevard County, Florida

DRAWN BY: JPK

REFERENCE: PROVIDED BY
CCAFS

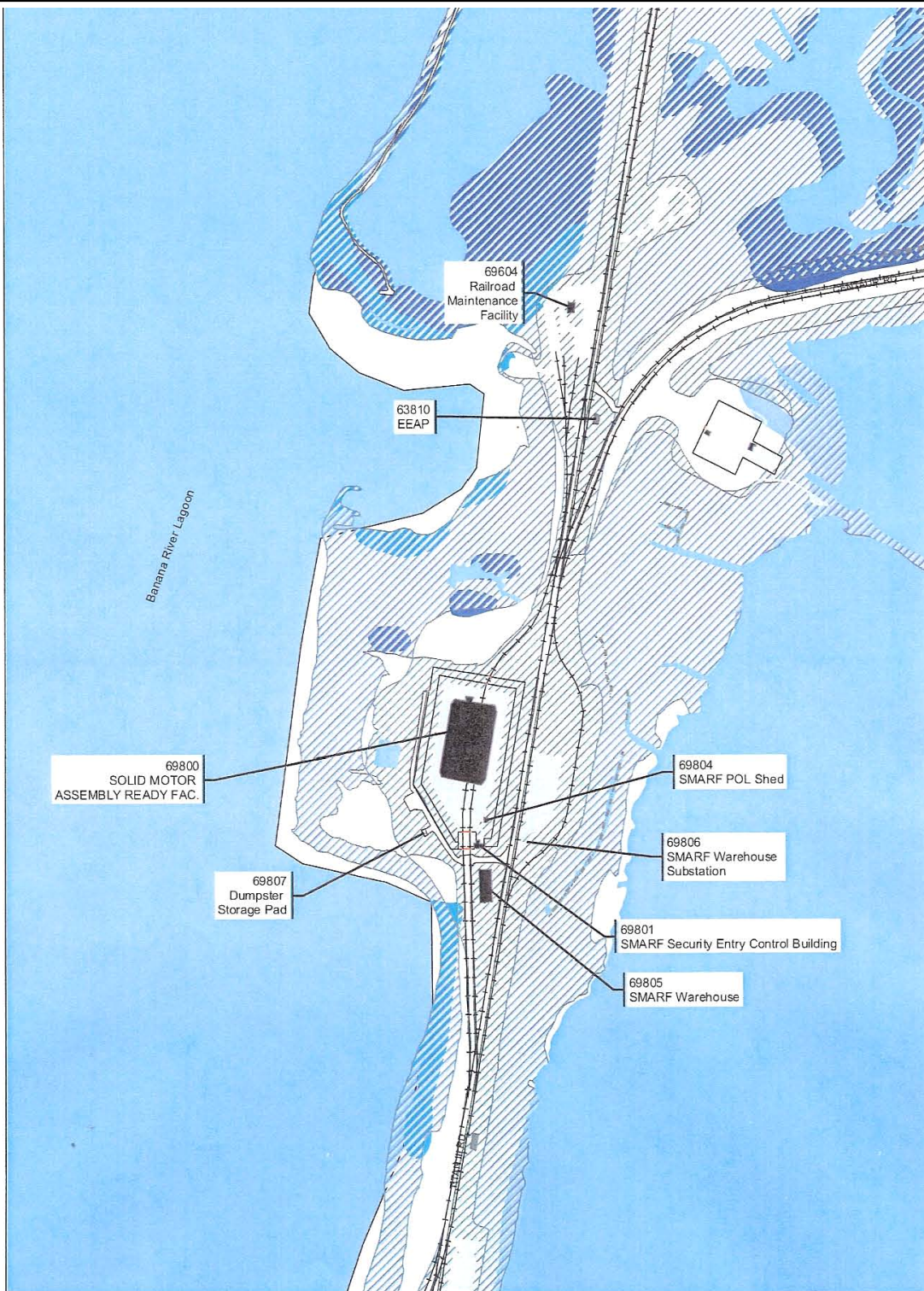

SMARF NWI wetlands and Flood Plains

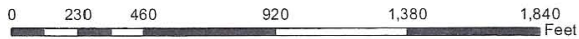

Legend		Flood Plains
Gate	Railroad	Sub Type Identifier
Fence	Road	100_YEAR
Tower Site	Parking	500_YEAR
Shed	Driveways	Estuarine
Pavilion	OPEN_DRAINAGE	Lacustrine
Structures	PAVED_DITCH	Palustrine
	UNPAVED_DITCH	Beverd
	Water	

Figure 3-6: SMARF Area NWI Wetlands and Flood Plains



FIG 3.3-5 WETLANDS AND FLOODPLAIN SMARF



Environmental Assessment
 Space X Falcon 1 and Falcon 9
 Launch Program
 Cape Canaveral Air Force Station
 Brevard County, Florida

DRAWN BY: JPK

REFERENCE: PROVIDED BY
 GOOGLE

4.0 ENVIRONMENTAL CONSEQUENCES

This section discusses the potential space environmental consequences or impacts associated with the Proposed Action, Alternative 1, Alternative 2, and the No-Action Alternative. Changes to the natural and human environment that could result from the project alternatives were evaluated relative to the existing environmental conditions described in Section 3.0. A major focus of Section 4.0 is to analyze the level of significance associated with project-related environmental impacts and to specifically determine if any of the impacts could be classified as significant. The assessment of potential impacts and the determination of their significance are based on the requirements in 40 CFR 1508.27. Three levels of impact can be identified:

- No Impact- No impact is predicted,
- No Significant Impact- An impact is predicted, but the impact does not meet the intensity/context significance criteria for the specified resource, and
- Significant Impact- An impact is predicted that meets the intensity/context significance criteria for the specified resource.

Under NEPA (42 U.S.C. 4321 *et seq.*), significant impacts are those that have potential to significantly affect the quality of the human environment. Human environment is a comprehensive phrase that includes the natural and physical environments and the relationship of people to those environments (40 CFR Section 1508.14). Whether an alternative significantly affects the quality of the human environment is determined by considering the context in which it would occur along with the intensity of the action (40 CFR Section 1508.27). The context of an action is determined by studying the potential region of influence (ROI), which for this project is the specific SLCs discussed (SLC40, 36A/B, 47), CCAFS and in some cases Brevard County, and affected interests within each. Significance varies depending on the physical setting of an alternative (40 CFR Section 1508.27). The intensity of an action refers to the severity of the impacts, both regionally and locally, and may be determined by:

- Overall beneficial project effect versus individual adverse effect(s);
- Public health and safety;
- Unique characteristics in the area (i.e., wetlands, parklands, ecologically critical areas, cultural resources, and other similar factors);
- Degree of controversy;
- Degree of unique or unknown risks;
- Precedent-setting effects for future actions;
- Cumulatively significant effects;
- Cultural or historic resources;
- Special-status species or habitats; and/or
- Compliance with federal, state, or local environmental laws.

The level at which an impact is considered significant varies for each environmental resource. Resource-specific definitions of what constitutes a significant impact also tend to be defined by case law at any particular time and is therefore somewhat relative to the time at which an impact may occur. The function of this section then is to analyze each of the 14 resource areas so that the EA reviewer can reasonably conclude if a specific program activity would result in no impact, no significant impact, or a significant impact to a specific resource area based on the above general categories. Additionally, Launch vehicle impacts from space craft launches at launch sites covered by this EA have been analyzed in previous NEPA documents such as the Evolved Expendable Launch Vehicle (EELV) Final EIS (ET 1998) and NASA Routine Payload Final Environmental Assessment (June 2002) and were used as the “generic standard” for launch vehicles and space crafts. Also, the Programmatic Assessment for Reactivation/Reuse of Launch Complexes on CCAFS (2005) document provided background information for environmental impacts associated with the reuse/reactivation of one or more SLCs and the construction of a possible new SLC based on currently known conditions. These documents were used to compare possible impacts of the Falcon launch program.

4.1 LAND USE ZONING / VISUAL RESOURCES

The Proposed Action would occur primarily at SLC 40 and at the SMARF, which is designated for space launch activities. Operations would be consistent with both the Base General Plan and the Air Force mission at CCAFS. The Proposed Action would not convert prime agricultural land to other uses; result in a decrease in the land's productivity; or conflict with existing uses or values of the project area or other base properties. Therefore, the Proposed Action would generate no significant impacts on on-base land use.

4.1.1 Proposed Action - SLC 40

Activities at SLC 40 and the SMARF would be in conformance with its designated use (for space launch activities), and the Falcon 9 launch erector and umbilical tower, at approximately 100 feet would be present only during a launch, and would have a smaller height and profile than the existing MST and UT at SLC 40. The SpaceX facilities would have less visual presence/impact than that of prior SLC-40 activities and would not be visible by the public except possibly from the ocean. Therefore, the Proposed Action would generate no significant impacts on visual resources within the flight range of the Falcon launch vehicles.

Issuance of a federal license or permit for an activity in or affecting a coastal zone must be consistent with the Coastal Zone Management Act, which is managed by the Florida Department of Community Affairs.

Potential noise impacts on humans in the coastal zone are discussed in Section 4.2, Noise, and potential noise impacts on wildlife in the coastal zone are discussed in Section 4.3, Biological Resources.

4.1.1.1 Construction and Refurbishment Impacts

As SLC-40 is designated for space launch activities, construction of the proposed 90,000 ft² vehicle assembly building and payload processing facility, plus associated vehicle movement aprons within the existing SLC 40 footprint and other refurbishment activities at SCL 40 or the SMARF would not generate negative land use or zoning impacts on the project area and surrounding areas.

4.1.2 Alternative 1 – SLCs 36 A and B

Implementation of the Proposed Action would be in conformance with its designated use (for space launch activities), and the Falcon 9 launch erector and umbilical tower, at approximately 100 feet would

be present only during a launch, and would have a smaller height and profile than the existing MST and UT at SLC 36A/B. However, SLC 36 is currently listed in CCAFS Zone 3 of the CCAFS General Plan which is planned to be reserved for small and medium lift launch vehicles. While the Falcon 1 is considered a light lift vehicle, the Falcon 9 launch vehicle is a “medium” lift platform which is addressed in this EA. A future Falcon 9 variation includes a “heavy lift” capability. Therefore there would be a conflict and potential impacts of deploying future heavy lift vehicles at SLC 36 A/B, although this would not be expected to be a significant impact.

4.1.3 Alternative 2 – SLC 47

SLC 47 is currently a small concrete pad used to launch relatively small weather related rockets, and it is located 500 ft from the Atlantic Ocean. Intense and disruptive construction activities required to implement the action would cause impact to the coastal zone. Implementation of Alternative 2, SLC 47, which is located immediately adjacent to the eastern coastline approximately 500 feet from the shoreline would present the largest impact to the Coast Zone since approximately 10-40 acres would be disturbed by required new construction thereby changing the visual aspect of the beach in that area. Resultant structures would be visible from the beach area.

4.1.4 No-Action Alternative

Under the No-Action Alternative, the Falcon Launch Vehicle Program would not be implemented; therefore, there would be no operation or refurbishment impacts on land use and no impact.

4.2 NOISE

Noise impact criteria are based on land use compatibility guidelines and on factors related to the duration and magnitude of noise level changes. Annoyance effects are the primary consideration for most noise impact assessments on humans. Noise impacts on wildlife are discussed in Section 4.3, Biological Resources.

Because the reaction to noise level changes involves both physiological and psychological factors, the magnitude of a noise level change can be as important as the resulting overall noise level. A readily noticeable increase in noise levels would often be considered a significant effect by the local residents, even if the overall noise level was still within land use compatibility guidelines. On the other hand, noise level increases that are unnoticed by most people are not considered a significant change, even if the overall noise level is somewhat above land use compatibility guidelines. Finally, certain noise levels (e.g., from sonic booms) have the potential to break glass or damage structures.

Some published thresholds for noise impacts on humans include the following:

- A DNL of 65 dBA, or a CDNL of 61 dBC for sonic booms or rocket noise, is the generally accepted limit for outdoor noise levels in residential areas (Departments of the Air Force, Army, and Navy 1978; Department of Housing and Urban Development 1978). Project related noise levels 5 dB or more above 65 dBA or above 61 dBC would be considered a significant impact.
- Project-related overpressures above 1 psf would have the potential to break glass or cause damage to structures, and therefore, would be considered a significant impact.

- Temporary noise sources such as refurbishment and demolition that are restricted to daytime hours would be considered significant if they resulted in noise levels 10 dB or more above the 85 dBA noise threshold limit value for construction workers in an 8-hour day.

4.2.1 Proposed Action – SLC 40

4.2.1.1 Operation Impacts

Noise generated during operation of the Proposed Action is discussed below in terms of engine noise and sonic boom noise. As the Falcon 9 has yet to be launched, actual noise levels that would be generated from the vehicle are unknown. However, engine noise from the Falcon vehicle was modeled from actual noise levels measured during engine tests on the Merlin Engine from the Falcon 1.

For the purposes of this EA, modeled noise levels for the Falcon 1 vehicle are compared with actual and modeled noise levels from launches of the Atlas IIAS launch vehicle at Vandenberg AFB to evaluate noise impacts. Table 42-1 presents a comparison of the specifications of the Falcon vehicle and the Atlas IIAS vehicle. In terms of size and configuration, the Falcon 1 vehicle is significantly smaller in comparison to the Atlas IIAS vehicle; Launches from SLC-3E Vandenberg AFB are currently approved for the Atlas IIAS.

T a b l e 4 . 2 - 1
Comparison of the Falcon Vehicle Specifications with the Atlas IIAS Vehicle Specifications

Launch Vehicle	Vehicle Weight (lbs)	Height (feet)	Fuel Types
Falcon 1	49,000	68	LOX RP-1
Atlas IIAS	413,500	156	LOX RP-1 Anhydrous hydrazine Liquid hydrogen Ammonium perchlorate

Notes:

Use of deluge water systems for noise suppression is assumed for each vehicle. Source: U.S. Air Force I998a.

Noise data on the Atlas IIAS was obtained from noise monitoring conducted on launches by SRS Technologies (SRS Technologies 2000, 2001). Data from the SRS Technologies reports include both measured engine noise levels and predicted sonic boom footprints for launches of the Atlas IIAS that occurred in December 1999 and September 2001(USAF 2003).

Engine Noise

Noise levels for the Falcon I vehicle were modeled using noise measurements taken on the Falcon vehicle engine in April 2003. Noise measurements were taken 200 feet from the engine, 60 degrees off the engine axis; a maximum unweighted noise level of 145 dB was measured at this location. From this data and an estimated atmospheric attenuation rate of 0.22 dB per 100 meters (SRS Technologies 2000, 2001), unweighted noise levels at 1, 3, 5, 7, and 9 miles from SLC-3 at Vandenberg

AFB were calculated for the Falcon vehicle (see Table 4.2-2). Appendix F shows the results of the engine noise level modeling for the Falcon 1 launch vehicle, containing one Merlin Engine in the first stage. The Falcon 9 launch vehicle contains nine identical Merlin Engines the first stage. SpaceX is currently conducting various sound testing for the Falcon 9 launch vehicle.

Maximum unweighted rocket noise levels from actual Atlas IIAS vehicle launches are shown in Table 4.2-2. These values are based upon measurements of SELs at 9.9 kilometers from SLC-3E (SRS Technologies 2000 and 2001). These values were subsequently extrapolated to produce noise contours at varying distances from the launch site for the purposes of this EA.

T a b l e 4 . 2 - 2
Comparison of Engine Noise Levels from the Falcon Vehicle and the Atlas IIAS Vehicle (dB)

Distance from Pad (miles)	Actual Noise Levels from the 19 December 1999 Atlas IIAS Launch	Actual Noise Levels from the 8 September 2001 Atlas IIAS Launch	Modeled Noise Levels for the Falcon 1 Vehicle
1	158.2	152.0	113.3
3	141.6	135.4	96.7
5	130.1	123.9	85.2
7	120.1	113.9	75.2
9	110.8	104.6	65.9

On average, modeled engine noise levels from the Falcon vehicle are approximately 39 to 45 dB lower than the Atlas IIAS noise levels. These noise levels are in dBs, where the full spectrum is considered rather than the partial spectrum used in the A-weighted measurement. When converted to an A-weighted scale (by subtracting 34.4 dB), modeled noise levels for the Falcon 1 vehicle is predicted to be approximately 41 dBA in the city of Cape Canaveral (at 7 miles from the launch pad) and 90 dBA at the launch site (approximately 2,000 feet from the launch pad). Noise at this level would effectively continue for approximately 20 seconds and then decrease significantly to levels below 85 dBA.

Based on modeled engine noise levels for the Falcon 1, it is anticipated that noise levels under the Proposed Action would not (1) exceed the DNL threshold of 65 dBA in nearby residential areas (Cape Canaveral) or (2) exceed the 85 dBA noise threshold limit value recommended for workers in an 8-hour day. In addition, engine noise levels would be considerably less than those generated by an Atlas IIAS size launch vehicle.

Based on the information above, Falcon 1, with one Merlin Engine is not expected to have a noise impact on local or surrounding areas. Table 4.2-3 below shows modeled Falcon 9 acoustic levels, Overall Sound Pressure Levels (OASPLs). These figures include an uncertainty factor of 3 dBA, and the affect of the water deluge system was not taken into account (SPACEX 2007a).

T a b l e 4 . 2 - 3
Modeled engine noise for the Falcon 9 Launch Vehicle

Distance (ft) From Pad	Unweighted (dB) OASPL
1,000	141
2,500	133
5,000	127
10,000	121
36,960 (7 miles)	109

Sonic Booms

Sonic boom modeling was performed for the Falcon 1 launch vehicle by The Aerospace Corporation (The Aerospace Corporation 2003) to determine overpressure levels and sound levels generated by the sonic boom from the Falcon vehicle based upon three different launch trajectories and under two different atmospheric conditions at Vandenberg AFB. The results of the sonic boom modeling are contained in Appendix G. Modeling was prepared using two atmospheric cases: (1) a December atmosphere with mean (nominal), high, and low December winds and (2) a 1971 standard atmosphere model with "no winds" for Vandenberg AFB. Results of the sonic boom modeling for the Falcon vehicle were also compared with results of sonic boom modeling from an actual launch of the Atlas IAS in September 2001; sonic boom overpressure levels for the Atlas IAS are shown in Appendix G. Table 42-4 summarizes maximum overpressure levels for both the Falcon vehicle and Atlas IAS vehicle (USAF 2003).

Maximum overpressure levels for sonic booms predicted for the Falcon were converted to A-weighted decibels in Appendix G. Maximum A-weighted sonic boom noise levels from the Falcon vehicle are as follows: 95.9 dBA for a 160-degree launch azimuth, 91.1 dBA for a 175-degree launch azimuth, and 99.5 dBA for a 190-degree launch azimuth under mean December wind conditions. Since sonic boom pressure waves and resultant impact noise levels occur down track and since all launch trajectories are over the ocean, sonic noise would occur away from the coastline.

Overpressures between 6 and 8 psf have a high potential to damage structures, including the potential to break glass and cause damage to plaster, walls, and roofs (see Section 3.2, Noise). Sonic boom analysis of the Falcon 1 launch vehicle illustrates that under any of the modeled launch trajectories, peak overpressure values over water east of the coast would remain under 2.3 psf. This level is under the level required to cause structural damage. Therefore, impacts on humans due to sonic boom noise would also be less than significant under the Proposed Action.

T a b l e 4 . 2 - 4
Comparison of Maximum Sonic Boom Overpressure Levels from the Falcon 1 Vehicle and the Atlas IIAS Vehicle

Launch Trajectory (degrees)	Actual September 8, 2001 Atlas IIAS Launch (psf)	Modeled Falcon Launch (December launch)* (psf)	Modeled Falcon Launch (No Winds)* (psf)
157	4.0	NA	NA
160	NA	2.65	2.5
175	NA	10.14	1.79
190	NA	7.05	2.66

*Source: USAF EA for the Falcon Launch Program Vandenberg AFB,2003.

4.2.1.2 Construction and Refurbishment Impacts

A temporary increase in ambient noise levels would occur at SLC-40 or the SMARF during any refurbishment or building due to the operation of any heavy equipment (e.g., earth moving machinery, dump trucks). No residential areas or other sensitive receptors occur at, or near, SLC-40; therefore, refurbishment noise would not impact sensitive receptors. The closest residence is approximately 7 miles away.

Noise impacts from the operation of construction equipment are usually limited to a distance of 1,000 feet or less. Typical heavy construction equipment is muffled to not exceed the 85 dBA noise threshold limit value recommended for construction workers in an 8-hour day (American Conference of Governmental Industrial Hygienists 1992-1993). Most noise from an assumed 85 dBA source would attenuate to less than 75 dBA in about 200 feet and to less than 65 dBA, which is the level generally considered a threshold criterion for significance, within 800 feet. It is not anticipated that refurbishment activities at SLC 40 or the SMARF, or construction of a new 90,000 ft² Vehicle Assembly Facility (hanger) would produce noise levels with adverse impacts on the potential endangered species located at the proposed action site (SLC 40) however the impact would not be considered significant.

In accordance with 29 CFR 1910, protection against the effects of noise exposure would be provided when the sound levels exceed those shown in table 4.2-5 when measured on the A scale of a standard sound level meter at slow response(USAF 2005b). When employees are subject to sound exceeding those listed, engineering or administrative controls would be utilized and / or personal protective equipment such as approved ear plugs would be provided. Therefore, noise impacts on construction workers would be less than significant under the Proposed Action. Noise level impact on workers would be regulated through Air force procedures and Federal rules through 45 SW Range Safety, USAF, Occupational Safety and Health procedures, AFI guidelines and for OSHA compliance for safety related to noise impacts on workers, and any CCAFS Pad Safety prescribed guidelines for individual launch complexes would be

followed to protect worker safety related to noise levels. Monitoring of worker exposure to noise would be conducted as described in the Safety Plan for CCAFS.

T a b l e 4 . 2 - 5
Slow Response Sound Levels

Duration Per Day (Hours)	Slow Response Sound Level (dBA)
8	90
6	92
4	95
3	97
2	100
1.5	102
1	105
0.5	110
0.25 or less	115

*Source: USAF Final EA for Deactivation and Turnover of Titan Space Launch Vehicle Capability at CCAFS, May, 2005.

4.2.2 Alternative 1 - SLC 36 A and 36 B

Similar impact would occur for both launch operation and refurbishment related noise as discussed for the Proposed Action.

4.2.3 Alternative 2 - SLC 47

Similar impact for launch operation produced noise. However noise associated with construction would extend over a much longer time frame since significantly more construction activity would be needed to do site development work and construct a suitable launch pad and support facilities for the Falcon 1 and Falcon 9 launch vehicles.

4.2.4 No-Action Alternative

Under the No-Action Alternative, the Falcon Launch Vehicle Program would not be implemented; therefore; no operational or refurbishment noise would be generated.

4.3 BIOLOGICAL RESOURCES

Any action that may affect Federally-listed species or their critical habitats requires

consultation with the U.S. Fish and Wildlife Service (USFWS) under Section 7 of the Endangered Species Act of 1973 (as amended). Also, the Marine Mammal Protection Act of 1972 prohibits the taking of marine mammals, including harassing them, and may require consultation with the National Marine Fisheries Service (NMFS). The NMFS is also responsible for evaluating potential impacts to Essential Fish Habitat (EFH) and enforcing the provisions of the 1996 amendments to the Magnuson-Stevens Fishery Conservation and Management Act (MSFCMA) (50 CFR 600.905 et seq.). Discussions with both the USFWS and the NMFS about the Proposed Action have been initiated by the 45TH SW environmental department. Based on those discussions about the draft EA descriptions formal Section 7 consultation will not be required.

4.3.1 Proposed Action – SLC 40

4.3.1.1 Falcon 1 and 9 Vehicle Launch Impacts on Vegetation and Wildlife

Launch activities could have some small impacts near the launch pad associated with fire and acidic deposition similar to previous actions at the pad. NASA has mapped the effects on local vegetation of 14 Delta, 20 Atlas, and 8 Titan launches from CCAFS (SCHMALZER, 1998). Vegetation scorching has been limited to small areas (less than a hectare (2.5 acres)) within 150 m (492 ft) of the launch pad for Atlas and Titan launches. Acid and particulate deposition for Delta launches has extended less than 1 km (0.6 mi) from the launch pad and affected relatively small areas (up to 46 hectares (114 acres)). Continuous acid deposition has not exceeded 1 km (0.6 mi) from the launch pad for Titan launches. However, isolated acid deposition has occurred up to 9.3 km (5.8 mi) from the launch pad under certain meteorological conditions. Particulate deposition from Titan launches has occurred over larger areas (2,366 hectares or 5847 acres) and up to 14.6 km (9.1 mi) from the launch pad. No discernable vegetation or other environmental damage appears to be caused by this particulate deposition (USAF 1998). The Falcon 1 and Falcon 9 program launch vehicles utilize liquid fuels (LOX and RPI) and there is comparatively less or very little expected acid or particulate deposition. Therefore, Falcon 1 and Falcon 9 would affect a much smaller area to a much lesser extent. Prior to refurbishment and construction of SLC 40, gopher tortoises that are within the impact zone (area where fuel and chemicals have a potential to reach during rocket launch) will be relocated in accordance with FFWCC permit requirements.

No animal mortality has been observed at CCAFS that could be attributed to Delta, Atlas, or Titan launches (SCHMALZER, 1998). Similar results would be expected for Falcon 1 and Falcon 9 vehicle launches. Minor brush fires are infrequent by-products of launches and are usually contained and limited to ruderal vegetation within the launch complexes. Past singeing has not permanently affected the vegetation near the pads.

An anomaly on the launch pad would also present potential impacts to biological resources due to the possibility of extreme heat and fire, from percussive effects of the explosion, and from solid propellant fragments that might impact in surface waters. The explosion could injure or kill wildlife found adjacent to the launch pad or within debris impact areas. Potential fires started from the anomaly could result in a temporary loss of habitat and mortality of less mobile species (USAF 1998).

During a nominal launch, the launch vehicle and spacecraft would be carried over the Cape Canaveral coastal waters and on into orbit without impacts of any kind on the marine life or habitat. Only in the event of an early launch abort or failure where the spacecraft and launch vehicle debris would fall into this area would there be a potential impact. Launch vehicle debris from a liquid propellant vehicle is considered a negligible hazard because virtually all hazardous materials are consumed in the destruct action or dispersed in the air, and only structural debris remains could strike

the water.

4.3.1.2 Falcon Space Craft Affect on Marine Life

Even in a destruct action, the Dragon spacecraft or launch vehicle may survive to impact the water essentially intact, presenting some potential for habitat impact. This potential arises from the fact that some Falcon Program spacecraft may carry hypergolic propellants, which are toxic to marine organisms. Specifically, the Dragon spacecraft may carry nominal values of monomethylhydrazine (MMH) fuel (up to 1000 pounds in the envelope case) and nitrogen tetroxide (NTO) oxidizer (up to 1800 pounds in the envelope case) at lift off which is less than that of other spacecraft analyzed which may carry either hydrazine (N₂H₄) or monomethylhydrazine (MMH) fuel (up to 1000 kg or 2200 pounds in the envelope case) and nitrogen tetroxide (NTO) oxidizer (up to 1200 kg or 2600 pounds in the envelope case). A lesser hazard may exist from small amounts of battery electrolyte also carried on all spacecraft vehicles, but the risk from electrolyte is far smaller due to lesser quantities, lower toxicity and more rugged containment. Hence analysis focuses on the hypergolic propellants.

Comparatively, the reliability of the Delta launch vehicle is estimated to be approximately 98 percent, the highest demonstrated reliability of any American expendable launch vehicle (USAF 1998). A reliability of 95% is typically used for EELV launch vehicles. While SpaceX is determining quantitative values, reliabilities of the Falcon 1 and 9 are also expected to be in the upper 90 percent range. Hence, it is unlikely that a spacecraft would impact in the ocean. Depending on the precise timing and failure mechanism, several scenarios are possible if such an event did occur:

1. The entire spacecraft, with onboard propellants, is consumed in a destruct action
2. The spacecraft is largely consumed in the destruct action, but residual propellant escapes and vaporizes into an airborne cloud
3. The spacecraft survives to strike the water essentially intact, whereupon the propellant tanks rupture, releasing liquid propellants into surface waters
4. The spacecraft survives water impact without tank rupture and sinks to the bottom, but leaks propellant into the water over time

The probability of any one of these scenarios is unknown, but only the last two would offer potential impact to marine life or habitat. No. 3 would release the entire propellant load into surface waters, producing the highest concentrations (assuming no combustion on contact of fuel with oxidizer) whereas No. 4 would release propellant under water and produce lower concentrations over time. Although No. 3 may expose a few surface individuals to acute concentrations, it is believed that No. 4 would expose a greater number of individuals to chronic concentrations as feeding populations investigate, swim or float by the sunken satellite debris(USAF 1998).

The toxicology of hydrazine, MMH and nitrogen tetroxide with marine life is not well known. Nitrogen tetroxide almost immediately forms nitric and nitrous acid on contact with water, and would be very quickly diluted and buffered by seawater; hence, it would offer negligible potential for harm to marine life. With regard to hydrazine fuels, these highly reactive species quickly oxidize forming amines and amino acids, which are beneficial nutrients to small marine organisms. Prior to oxidation, there is some potential for exposure of marine life to toxic levels, but

for a very limited area and time. A half-life of 14 days for hydrazine in water is suggested based on the unacclimated aqueous biodegradation half-life (Howard, 1991).

In short, an improbable mishap downrange would occur over the open ocean and would not likely jeopardize any wildlife, given the relatively low density of species within the surface waters of these open ocean areas (USAF, 1998). Debris from launch failures has a small potential to adversely affect managed fish species and their habitats in the vicinity of the project area. However, after consultation with the NMFS, the Air Force found "no greater than minimal adverse effects" to essential fish habitat under NMFS regulations (USAF, 2000b).

4.3.1.3 Falcon Launch Affect on Threatened and Endangered Species

SLC 40

As indicated in Table 4.3-1, Florida scrub jays, gopher tortoise, southeastern beach mice, indigo snakes and sea turtle nesting occur in the vicinity SLC 40. Post launch monitoring conducted on previous launches, and previous environmental analyses (USAF, 1995a) concluded that launch impacts to these species are minimal and are not an issue. The behavior of scrub jays observed after Delta, Atlas, and Titan launches has been normal, indicating no noise-related effects (SCHMALZER, 1998). Prior to refurbishment and construction of SLC 40, gopher tortoises that are within the impact zone area (where fuel and chemicals have a potential to reach during rocket launch) will be relocated in accordance with FFWCC permit requirements.

Sonic booms created by launches from CCAFS launch complexes occur over the open Atlantic Ocean. The effects of a sonic boom on whales or other open ocean species are not known. Because these sonic booms are infrequent, the marine species in the ocean's surface waters are present in low densities (although spring and fall migration would see periodic groups of migrating whales that follow the coastline), and the sonic boom footprint lies over 38 km (30 mi) from CCAFS, the sonic booms from launches are not expected to negatively affect the survival of any marine species (USAF, 1998). Additionally, implementation of the proposed action at SLC 40 would also have less impact on 45th SW's burning program since the launch vehicles are designed to have shorter "stay time" at the launch pad.

Facility Lighting

Night lighting at the launch pads has been a concern at CCAFS because of the potential for sea turtle hatchlings at the beach to be drawn toward the lights instead of toward the surf. Potential negative impacts by lighting is reduced and managed by a 45 SW Instruction which addresses exterior Lighting Management" which has been implemented by a series of management plans specific to all active launch complexes as well as the CCAFS Industrial Area. These plans require the use of low-pressure sodium light fixtures, shielding and special light management steps where lights are visible from the beach areas. All construction and operational activities must have a light management plan approved by the FWSS. Exterior lighting at all facilities used for spacecraft processing at CCAFS would comply with established lighting policy for minimizing disorienting effects on sea turtle hatchlings.

SMARF

As indicated in Table 4.3-1, the gopher tortoises, the scrub jays, the southeastern beach mouse

and sea turtle nesting are not on or within the vicinity of the SMARF, however lighting can impact nesting and hatching sea turtles. Therefore, launch operations are not expected to impact these species. The SMARF would be included in the LMP for the Falcon program.

4.3.1.4 Construction

At CCAFS, potential impacts to biological resources could occur from ground-disturbing construction activities at SLC 40 for the proposed Vehicle Assembly and Payload Processing Facility (hanger). Modifications would take place in an already developed area, and therefore would not entail new ground disturbance. The vegetation at most of the SLCs is a mixture of mowed grasses and forbs. Construction of the launch facilities would cause minimal impact to the native vegetation in the area because the area has been previously disturbed and little native vegetation remains. There would be no disturbance of wetlands as there are no wetlands within the boundary of SLC 40. Biological resource impacts would not be expected from use or construction of these facilities. Implementation of the proposed action at SLC 40 would also have less impact on 45TH SW's burning program since the launch vehicles are designed to have shorter "stay time" at the launch pad.

As indicated in Table 4.3-1, gopher tortoise, southeastern beach mice, scrub jay and sea turtles have historically been on or in the vicinity of SLC 40.

A survey for gopher tortoises and indigo snakes would be conducted prior to any construction activity at SLC 40. If gopher tortoises are within 25 feet of any construction, those tortoises would be relocated to another area that is sufficiently out of the impact zone in accordance with the Air Force Gopher Tortoise Relocation Permit. .

Temporary noises and ground vibrations would occur during construction and refurbishment of SLC 40 that could temporarily disturb wildlife in the immediate area. Wildlife should be monitored to determine if noise is a factor. If noise is determined to affect nearby wildlife, the activities at a specific SLC would need to be evaluated.

Marine life would not be affected by construction and refurbishment because this activity would occur on land within the boundary of SLC 40. In order to insure that the lighting of the facility does not impact sea turtles, a light management plan would be approved by USFWS and implemented prior to construction activities and activation of the launch facility. Lighting associated with construction and refurbishment would comply with established lighting policy for minimizing disorienting effects on sea turtle hatchlings.

Table 4.3-1 shows which T&E species are located near or around the SLCs discussed in this EA.

T a b l e 4 . 3 - 1
Threatened and Endangered Species Matrix

	Scrub-Jay	Gopher Tortoise	SE Beach Mouse	Sea Turtle	Indigo Snake
SLC 36A	V	S V	V	V	V
SLC 36B	V	V	V	V	V
SLC 40	V	S V	V	V	V
SLC 47	V	S V	V	V	V
SMARF	-	-	-	-	-

S – The species has been identified as being present on the SLC
V – The species has been identified as being present in the immediate vicinity of the SLC
-- The species is not known to be present

Shaded - Impact to T&E species expected from reuse/reactivation

4.3.2 Alternative 1 – SLCs 36 A and 36 B

This section discusses the effects to biological resources as a result of construction and launch activities associated with the reuse/reactivation of both SLCs. Falcon Space Craft effects on marine life are essentially the same as for SLC 40.

4.3.2.1 Falcon 1 and Falcon 9 Launches Effects on Species

As indicated in Table 4.3-1, gopher tortoise, southeastern beach mouse, sea turtle nesting and indigo snakes are known to occur on or within the vicinity of SLCs 36A and 36B. A survey for gopher tortoises would be conducted prior to any activities within SLCs 36A and 36B. If gopher tortoises are within 25 feet of any construction, those tortoises would be relocated to another unoccupied burrow or starter burrow that is sufficiently out of the impact zone (area where fuel and chemicals can not reach the burrow). A tortoise relocation permit would be sought through the FFWCC prior to initiation of construction and refurbishment at SLCs 36A and 36B.

A survey for beach mice and indigo snakes would be required prior to any activity at SLCs 36A and 36B. If beach mice and indigo snakes are located on or within the vicinity of SLCs 36A and 36B, a section 7 consultation with the USFWS would commence, so that beach mice could be trapped and relocated.

In order to insure that the lighting of the facility does not impact sea turtles, a light management plan would be approved by the USFWS and implemented prior to activation of the launch facility.

4.3.2.2 Construction or refurbishment at SLC 36

Impacts to vegetation would be minimal and essentially the same as for the Proposed Action. Wetlands occur on the edges of the SLCs 36A and 36B. Impacts could occur to the adjacent wetlands if plans included altering the perimeter of the SLC. Any planned alterations would include acquisition of appropriate Section 404 permits. Biological resource impacts would not be expected from use or construction of these facilities; construction of the approximate 300 ft x 300 foot vehicle assembly and Payload processing facility would be sited in a previously disturbed area.

SLC 36 is located in the vicinity of Gopher tortoises, the southeastern beach mouse and or sea turtles and could require relocation efforts and/or regulatory agency coordination prior to and during construction activities. Surveys for gopher tortoise and beach mice would be needed prior to any activity at SLC 36. If gopher tortoises are found to be present, a gopher tortoise relocation plan would be prepared and approved by FFWCC prior to construction. If beach mice were found, consultation under Section 7 would commence with the USFWS so that beach mice could be trapped and relocated. In order to insure that the lighting of the facility does not impact sea turtles, a light management plan would be approved by the USFWS and implemented prior to activation of the launch facility. The encroachment on their environment by reusing/reactivating both SLCs would require additional coordination and monitoring to ensure that the populations are not decreasing.

4.3.3 Alternative 2 – SLC 47

This section discusses the effects on biological resources as a result of construction and launch activities associated with the construction of a new SLC 47. The impacts to species of special concern and threatened and endangered species would be minimal if measures are implemented to monitor and reduce impacts. Falcon Space Craft effects on marine life would essentially be the same as for SLCs 40

and 36. The affects on biological resources for Falcon 1 and 9 launches would be similar to those explained above in Section 4.3.1.

Construction

Potential impacts to biological resources could occur from ground-disturbing construction activities at the new proposed SLC. Because new construction would have to occur in undeveloped land there would be greater relative impact here than at SLC 40 or SLC 36. Additionally, since the SLC perimeter is much closer to the beach there would also be greater potential adverse affects on turtles due to facility lighting from construction and from the resulting complex. Finally, Phillips Parkway immediately to the west would probably have to be re-routed further to the west, bringing it closer to adjacent wetlands. Biological resource impacts may be expected from use or construction of these facilities. This area is currently minimally disturbed and the impact to vegetation from most launch programs would be greatest for this alternative.

As shown in Table 4.3-1, gopher tortoises, the Florida scrub-jay and the southeastern beach mouse have been identified as being present on or in the vicinity of the proposed new SLC location. Prior to construction, a biological survey of this site would likely be required. If the survey identifies threatened and endangered species that would be affected by the construction of a new SLC, removal efforts and regulatory agency coordination would be required.

Mitigation measures would likely be required for the Florida scrub-jay and the gopher tortoise if a new SLC were constructed at SLC 47. According to the INRMP (2002), projects occurring on CCAFS that have the potential to adversely impact scrub jays are reviewed through the Section 7 Consultation process. Loss of scrub habitat would be compensated at a ratio of 4:1 (every acre lost would require compensation in the amount of four acres), in accordance with the CCAFS Scrub Compensation Plan. In addition, clearing activities associated with certain projects may be restricted to those months outside the scrub-jay nesting season (1 March – 30 June). In order to insure that the lighting of the facility does not impact sea turtles, a light management plan would be approved by the USFWS and implemented prior to construction activities and activation of the launch facility. Wildlife should be monitored to determine if noise is a factor. If noise is determined to affect nearby wildlife, the activities at a specific SLC would need to be evaluated.

Prior to any construction or excavation activities, a biological survey would need to be conducted to identify gopher tortoises present at the site. This survey would include a burrow count and habitat characterization and be conducted in accordance with FWCC guidelines. If gopher tortoises are found to be present, a gopher tortoise relocation plan would be prepared and approved by FWCC prior to construction.

A survey for beach mice would be required prior to any activity at SLC 47. If beach mice are located on or within the vicinity of the SLC, a Section 7 consultation with the USFWS would commence so that beach mice could be trapped and relocated.

4.3.4 No-Action Alternative

Under the No-Action Alternative, no changes to the vegetation or species of special concern, threatened and endangered species are proposed, and no construction or modification of facilities would occur; therefore, no impacts to vegetation or, species of special concern, threatened and endangered species are expected.

4.3.5 Cumulative Impacts

Some vegetative damage may occur from occasional brush fires and/or heat from the launch and wet deposition in the near-field areas. The loss of tree and shrub species and an increase of grass and sedge species may occur. Far-field vegetation should recover between launches since far-field deposition would not occur in the same area after each launch (NASA 1998).

Potential cumulative impacts to the scrub jays, gopher tortoises, and beach mice could result from habitat alteration or disturbance. There should be no significant impact on terrestrial wildlife from the exhaust cloud since it remains in any one area for a very short time (NASA 1998). The implementation of a light management plan to reduce beach lighting during the nesting season should reduce adverse impacts to sea turtles.

4.4 CULTURAL RESOURCES

The ROI for possible impacts on cultural resources has been determined to be the individual SLCs and the area immediately surrounding the particular SLC.

4.4.1 Proposed Action - SLC 40

Based on the SHPO letter (2001) indicating that SLC 41 was not NRHP eligible, the CRM concluded that since SLC 40 was used for the same purpose and had its MST and UT completely renovated in 1990-1993, it too did not qualify for NRHP. Therefore, SLC 40 is not considered a historic complex and there are no historic properties or known archeological sites located in the immediate vicinity. No significant impact to known historic or archeological resources would occur as a result of reactivation or reuse of these facilities.

4.4.2 Alternative 1 – SLCs 36 A and 36 B

While it's historical importance in the early development of the Atlas and Atlas/Centaur programs was noted, and potential SLC 36 eligibility for listing on the National Register of Historic Places, that action did not happen. Level II HABS/HAER documentation of the site was completed. The facility is currently undergoing demolition activities under another CCAFS Project; therefore the reuse of this facility for launch vehicles other than the Atlas would not result in any significant impact to cultural resources.

4.4.3 Alternative 2 – SLC 47

SLC 47 is not considered a historic complex and there are no known historic properties located in the immediate vicinity. This site would entail a new launch complex constructed east of Phillips Parkway between existing SLC 40 to the north and SLC 37 to the south. No significant impact to known historic or known archaeological resources would occur from development of a new SLC in this area. However, since areas close to the ocean which would need to be cleared should be considered to have an elevated potential for prehistoric archeological sites (a Moderate Area of Archaeological Potential) and because there are two known archeological sites within one half mile of the proposed site, the SLC and vicinity should be subject to a formal archaeological survey.

4.4.4 No-Action Alternative

The No-Action Alternative scenario assumed not adding the Falcon 1 and 9 Launch Program to CCAFS. With the No-Action Alternative, no additional or refurbished launch site and no change in launch rates or activity would occur. Under the No-Action Alternative, there are no cultural, archeological, or historical resources that would be affected. The facilities at SLC 36 and 40 would continue to be managed consistent with established protocols, therefore there is no significant impact anticipated for cultural resources for SLC 36 or 40.

4.5 AIR QUALITY

This section describes the potential effects to air quality resulting from either implementation of the Proposed Action, the Alternatives to the Proposed Action or the No-Action Alternative. The ROI for Air Quality includes all of CCAFS and Brevard County, and both lower and upper atmospheres. Consequently, while the organization of this section addresses the Proposed Action (at SLC 40) and Alternative Locations at SLC 36A and B, and SLC 47, the actual impact of the Falcon 1 and 9 launch program on air quality would be the same for all locations.

4.5.1 Proposed Action SLC 40

4.5.1.1 Falcon 1 and Falcon 9 Vehicle Launch

The following analysis compares the Falcon launch vehicles to previously analyzed vehicles and spacecraft as part of NASA's routine payload final Environmental Assessment (June 2002). In that document all candidate launch vehicles considered for launch of routine payload spacecraft at CCAFS were reviewed through the environmental impact analysis process and determined to have no substantial impact on ambient air quality. In addition, range safety regulations at CCAFS prohibit launches when air dispersion models predict a toxic hazard to the public. Consequently, the public in and around the launch sites is unlikely to be exposed to concentrations of any launch vehicle emissions that exceed the allowable public exposure limits adopted by the range safety organizations.

4.5.1.1.1 Air Quality Impacts from Launch Vehicles

Air dispersion models are used at CCAFS to predict toxic hazard corridors for nominal launches, catastrophic launch failures, and spills of liquid propellants. Among the models used are the Rocket Exhaust Effluent Dispersion Model (REEDM), the Launch Area Toxic Risk Assessment Model (LATRA), and the Ocean Breeze/Dry Gulch (OB/DG) model. As documented in previous EAs and EISs performed for the launch vehicles at CCAFS, these emissions would not substantially impact ambient air quality or endanger public health. The potential for an accidental release of liquid propellants would be minimized by adherence to applicable U. S. Air Force and NASA safety procedures. All spills would be managed in accordance with a spill response plan already in place at CCAFS.(EELV FEIS 1998)

4.5.1.1.2 Nominal Launches

Comparison launch vehicles for the Falcon 1 and Falcon 9 launch vehicles include the Athena, the Atlas family, the Delta family, Pegasus, Taurus, and Titan II. The liquid engines and solid

rocket motors (SRMs) on these vehicles produce air emissions during liftoff and flight. The primary emission products from the Falcon liquid engines which use RP-1 (kerosene) and liquid oxygen (LOX) are carbon dioxide, carbon monoxide, water vapor, oxides of nitrogen, and carbon particulates. Most carbon monoxide emitted by liquid engines is oxidized to carbon dioxide during afterburning in the exhaust plume. Table 4.5-1 shows actual emissions from the Falcon vehicles during a recent test conducted by SpaceX (SPACEX 2007b).

T a b l e 4 . 5 - 1
Merlin Engine Exhaust Species

MIC Mass Fractions			Exhaust Mass		Entrained Air Mass		Air/Exhaust Mixed Plume Emission		
	Chamber	Exit	Flow		Flow		Mass Flow (40 V/Vo)		Mass %
CO	44.55%	37.84%	1226.1	lbm/sec	0	lbm/sec	9.717	lbm/sec	0.0027%
CO2	24.05%	34.59%	1120.6	lbm/sec	0	lbm/sec	3032.1	lbm/sec	0.84%
H	0.14%	0.00%	0	lbm/sec	0	lbm/sec	0	lbm/sec	0.00%
HCO	0.00%	0.00%	0	lbm/sec	0	lbm/sec	0	lbm/sec	0.00%
HO2	0.01%	0.00%	0	lbm/sec	0	lbm/sec	0	lbm/sec	0.00%
H2	1.01%	1.24%	40	lbm/sec	0	lbm/sec	0	lbm/sec	0.00%
H2O	25.40%	26.33%	853	lbm/sec	0	lbm/sec	1213.4	lbm/sec	0.34%
H2O2	0.00%	0.00%	0	lbm/sec	0	lbm/sec	0	lbm/sec	0.00%
O	0.48%	0.00%	0	lbm/sec	0	lbm/sec	0	lbm/sec	0.00%
OH	3.29%	0.00%	0.2	lbm/sec	0	lbm/sec	0	lbm/sec	0.00%
O2	1.07%	0.00%	0	lbm/sec	74747.8	lbm/sec	73732.4	lbm/sec	20.49%
N2	0.00%	0.00%	0	lbm/sec	278582.8	lbm/sec	278582.8	lbm/sec	77.41%
Ar	0.00%	0.00%	0	lbm/sec	3318.2	lbm/sec	3318.2	lbm/sec	0.92%
Total	100.00%	100.00%	3240	Lbm/sec	356649	lbm/sec	359889	lbm/sec	100.00%
				Total air + exhaust:	359889	lbm/sec			

Notes: **F9 Flow Rate (9 x MIC) = 3240 lb/sec**
 Entrained Air (at 40 V/Vo) = 356792 lb/sec

Table 4.5-2 below lists the quantity of criteria pollutants and HCl that would be emitted into the lowest 915 m (3,000 ft) of atmosphere during each launch of the five comparison launch vehicles. The criteria pollutants include volatile organic compounds (VOC), nitrogen oxides (NOX), carbon monoxide (CO), sulfur dioxide (SO2), and particulate matter less than 10 microns in diameter (PM10).

Emission of aluminum oxide from the SRMs is included in the PM10 column. These five vehicles represent the largest emission sources from various combinations of liquid engines and SRMs on the comparison vehicles. Specifically, they represent: a) LH2/LOX engines (Delta IV-H), b) RP1/LOX engines (Atlas V Heavy), c) A-50/NTO engines (Titan II), d) LH2/LOX engines with SRMs (Delta IV M+ (5,4), and e) RP1/LOX engines with SRMs (Atlas V 551/552).

Table 4.5 - 2
Air Emissions (tons) Per Launch of Candidate Vehicles into Lowest 3,000 Feet of Atmosphere

Vehicle	VOC	Nox	CO	SO2	PM10	HCl
Delta IV Heavy	0	1.6	0	0	0	0
Atlas V Heavy	0	1.2	0	0	0	0
Titan II	0	0.04	0.06	0	0	0
Delta IV Medium+	0	0.71	0.0054	0	10	5.1
Atlas V 551/552	0	1.1	0.01	0	15	7.8

Sources: USAF, 2000a & USAF, 1987

4.5.1.1.3 Launch Vehicle Propellant Spills

The potential for an accidental release of liquid propellants would be minimized by adherence to applicable safety procedures as specified in AFSPC 91-710. All spills would be managed in accordance with SPCC plans. Liquid propellants, either RP-1 and liquid oxygen, would be stored in tanks near the launch pad within cement containment basins designed to retain 110 percent of the storage tank volumes. Propellant spills from the launch vehicle would be channeled into sealed concrete catchment basins and disposed of according to the appropriate Federal and State regulations. Propellant loading operations would be postponed if range safety models predicted that a potential propellant spill would result in a toxic hazard to the public or unprotected personnel.

4.5.1.1.4 Potential Launch Failures

In addition to scheduled launches, on rare occasions, a launch could fail. Such a failure would result in deflagration, in which the fuel from all stages is explosively burned. Deflagrations result in a very hot, extremely buoyant ground cloud that rises fast in particular atmospheric conditions that would occur during a planned launch at CCAFS, and that is typically dispersed over a wide area in the first 10,000 feet. (NASA Routine Payload Final EA 2002)

4.5.1.2 Impacts from Falcon Vehicle Payload Processing

4.5.1.2.1 Routine Payload Processing

The processing of routine payload spacecraft would consist of a number of steps to assemble, test, service, integrate, and launch the spacecraft. Some of these steps would be hazardous (such as propellant loading or ordnance installation). Specific activities identified as having potential environmental impact are described in this section. SpaceX plans to develop both the on-site SLC 40 combined vehicle assembly building (new construction) and the SMARF (refurbishment and modifications) into a payload processing facility (PPF). Cleaning of those facilities involves the use of solvents to remove organic contaminants. The standard solvent used is isopropyl alcohol (IPA), and approximately 208 liters (55 gallons) of IPA are used per mission (launch campaign). IPA is used because of its low toxicity and low flammability and it is not a listed/regulated HAPs pollutant. Ethyl alcohol may also be used for optical surfaces, but in very small quantities. It is non-toxic and somewhat flammable. Small amounts of other chemicals are often used incidentally in preparing spacecraft for assembly, test, loading, and launch. These are listed in section 4.1.1 and are used in such minor amounts and are of such low toxicity that they present no substantial potential for

adverse environmental impact.

Loading of hypergolic propellants would be performed either in the SMARF or the new proposed facility at SLC 40. The fuel may be MMH for bipropellant systems. The oxidizer used for bipropellant systems is NTO. Each loading operation would be independent, sequential and conducted using a closed loop system. During the operation, all propellant liquid and vapors would be contained. If small leaks occur during propellant loading, immediate steps would be taken to stop loading, correct the leakage, and clean up leaked propellant with approved methods before continuing. Personnel would wear protective clothing during hazardous propellant operations. Leakage would be absorbed in an inert absorbent material for later disposal as hazardous waste, or aspirated into a neutralizer solution. Propellant vapors left in the loading system would be routed to air emission scrubbers. Liquid propellant left in the loading system would be either drained back to supply tanks or into waste drums for disposal as hazardous waste.

Estimates of scrubber emission rates during typical payload vehicle fueling operations, based on the Titusville Astrotech PPF experience, are 0.045 kg/hr (0.099 lb/hr) for N_2H_4 , 0.13 kg/hr (0.28 lb/hr) for NTO and 0.064 kg/hr (0.14 lb/hr) for MMH. These rates are for typical periods of less than 30 minutes per spacecraft (ASTROTECH, 1993). Although both NTO and hydrazine are classified as hazardous air pollutants (HAPs), the NESHAP regulations under Title III of the CAA have not yet established control standards. The packed bed scrubber systems usually used are considered Best Available Control Technology (BACT) and should be considered acceptable when NESHAP regulations are promulgated.

The SMARF and SLC 40 Combined Vehicle processing facility would incorporate emergency power generators, either propane or diesel powered. Emissions from those generators may be regulated as stationary sources by the Florida Department of Environmental Protection (FDEP) for CCAFS and KSC, and would require permits from these agencies, depending upon design capacity, fuel, and expected operating hours per year.

4.5.1.2.2 Payload Propellant Spills

Inadvertent releases of toxic air contaminants are possible as a result of accidents during payload processing, transportation, and launch. The largest releases would result from the spillage of the entire quantity of liquid propellants. Lesser releases would result from fires or explosions that would consume significant fractions of the propellants. Safety procedures in place at CCAFS, which would be employed by SpaceX personnel, ensure that these events are unlikely to occur. In addition, spill response planning procedures are in place to minimize spill size and duration, as well as possible exposures to harmful air contaminants. The magnitude of air releases from payload accidents would be relatively small compared to possible releases from accidents involving launch vehicles. They would have no substantial impact on ambient air quality.

Appendix I documents the mean hazard distance predictions for release of the routine payload's maximum liquid propellant loads, which consist of 1000 kg (2200 lb) of hydrazine, 1000 kg (2200 lb) of MMH, and 1200 kg (2640 lb) of NTO. The U. S. Air Force Toxic Chemical Dispersion Model (AFTOX) Version 4.0 (Kunkel, 1991) was used to predict the mean hazard distances resulting from the spillage of each of the three liquid propellants. AFTOX is a simple Gaussian puff/plume dispersion model that assumes a uniform windfield. AFTOX was used to predict mean distances to selected downwind concentrations of each toxic vapor. The selected concentrations used for this analysis were the Short-Term Emergency Guidance Levels (SPEGLs) for hydrazine (0.12 ppm 1-hour average), MMH (0.26 ppm 1-hour average), and nitrogen dioxide (1.0 ppm 1-hour average). AFTOX runs were conducted for daytime and nighttime conditions

at two different wind speeds (2 and 10 m/s (7 and 32 feet per second)). These meteorological conditions were selected to illustrate possible hazard distances. Other meteorological conditions would produce different hazard distances but would not change the conclusion that the concentrations fall below hazardous levels within a relatively short distance of the release. Appendix I provides some AFTOX output relevant to this EA. Other acceptable modeling such as REEDM, LATRA, or OB/DG would be used by CCAFS with SpaceX input to verify parameters stated by AFTOX results.

Spillage of the entire payload propellant load, while unlikely, could occur during payload processing, payload transportation, payload mating to the launch vehicle, or during the actual launch operation. A launch accident could result in payload ground impact resulting in propellant tank rupture and spillage. The cases modeled by AFTOX are worst case since they assume that the spills are unconfined and evaporate to completion without dilution or other mitigating action. The following sections summarize the results presented in Appendix I and document the areas and distances that would temporarily have hazardous levels of the propellants in the event of a spill. These results indicate that the chemicals are diluted to non-hazardous levels in reasonably short distances.

The mean hazard distances predicted by AFTOX for the CCAFS and KSC area are discussed in Appendix I. In summary, all mean hazard distances for toxic air releases from payload accidents at CCAFS and KSC would be less than 5.7 km (3.4 mi) for the meteorological conditions considered. This would be the maximum distance downwind that would require evacuation and control by range safety authorities (NASA 2002).

4.5.1.3 Stratospheric Ozone Layer

4.5.1.3.1 Spacecraft and Launch Vehicle Processing

Ozone-depleting substances (ODSs), commonly used at CCAFS in cooling systems and fire-suppression systems, may only be used during pre-launch processing of routine payload efforts with Falcon spacecraft and launch vehicles when the required approvals have been obtained. Any ODS use would be accomplished in accordance with Federal, State, and local laws regulating ODS use, reuse, storage, and disposal. Release of materials other than propulsion system exhaust would be limited to inert gases. Since preparation of routine payload spacecraft would result in no release of ODSs into the atmosphere, there would be no impact on stratospheric ozone. All Class I ODS's are prohibited unless the contractor obtains Air Staff Senior Acquisition Officer (SAO) approval prior to a contract, lease or license being awarded and/or implemented.

4.5.1.3.2 Launch Vehicle Emissions

The Clean Air Act does not list rocket engine combustion emissions as ODSs, and therefore rocket engine combustion emissions are not subject to limitations on production or emissions restrictions for launches or engine testing. While not regulated, rocket engine combustion is known to produce gases and particles that reduce stratospheric ozone concentrations locally and globally (WMO, 1991).

The propulsion systems utilized by the Falcon 1 and 9 vehicles emit a variety of gases and particles directly into the stratosphere including H₂O, [NO_x, HO_x], and soot (carbon). A large fraction of these emissions are chemically inert and do not affect ozone levels directly. Other emissions, such as H₂O, are not highly reactive, but they do have an impact on ozone globally since they participate in chemical reactions that help determine the concentrations of ozone destroying

gases known as radicals. A small fraction of rocket engine emissions are the highly reactive radical compounds that attack and deplete ozone in the plume wake immediately following launch. Particulate emissions, such as carbon (soot), may also be reactive in the sense that the surfaces of individual particles enable important reactions that would not proceed otherwise.

The relative emission rate (mass of emitted compound per mass of propellant consumed) has not been accurately determined for all of the compounds. Rocket engine combustion computer models have been used to estimate the emission rates for some compounds (AEROSPACE, 1994). Direct measurements using high altitude aircraft have validated the model predictions in some cases (ROSS, 2000). The combustion models have not yet been used to estimate the rates for some important compounds, hydrogen oxides (HOx) for example, although theoretical considerations suggest they should be present in the exhaust in small quantities.

4.5.1.4 Launch Stand Refurbishment and Construction.

Refurbishment/Construction-related impacts could result from any construction equipment utilized (exhaust emissions) and activities associated with building the 300 x 400 ft Vehicle Assembly Building and Payload Processing facility at SLC 40. Activities included within construction activities estimates for CCAFS facility-wide include the renovation of existing structures and roads, the construction of new facilities and roads and the demolition of existing facilities. Analysis of construction emission sources includes estimating the amount of uncontrolled fugitive dust that would be emitted from disturbed surface areas and gaseous emissions from construction equipment and construction workers' vehicles.

Ongoing operational impacts could occur from: (1) mobile sources such as support vehicles, commercial transport vehicles, and personal vehicles; (2) point sources such as heating/power plants, generators, storage tanks, and flares (which there are none of this type point sources with this proposed action alternative at SLC-40); (3) processes such as limited solvent cleaning (for painting cleanup activities), coating, and any post-launch pad cleanup (expected to be insignificant for the proposed action for SLC-40 if selected); and (4) vehicle launch (as these are mobile source emissions the impact would be temporary to the lower atmosphere, and insignificant for the proposed action if SLC-40 is selected).

There are no cumulative or long-term negative air quality impacts associated with the proposed action. Emissions generated by launch stand refurbishment activities would be in the form of either gaseous or particulate pollutant emissions. Gaseous emissions would occur from heavy-duty construction equipment and vehicle travel to and from the site by construction workers. Emissions would consist primarily of combustion products from those vehicles and equipment, particulates and VOCs emitted from painting activities and minimal use of solvents. Particulates could be emitted from abrasive blast media usage to remove old paint. Particulate matter in the form of fugitive dust (PM_{2.5}, PM₁₀, and some lead) emissions could also be generated during the refurbishment phase if any site restoration or site prep activities occur. PM 2.5 and PM10 fugitive emissions can also occur with regular staff vehicle traffic on paved and unpaved surface areas.

Emissions resulting from launch refurbishment associated with the operation of the Proposed Action would include the following activities:

- Abrasive blasting;

- Coating and painting the launch structure after each launch; and
- Solvent-cleaning parts or painting equipment

Workers at the site would utilize their normal required dust protective wear when abrasive blasting where lead based paint is a possibility. A lead and PCB survey would be conducted prior to any refurbishment of the proposed action launch stand or buildings. All paint-stripping activities would be accomplished using containment equipment such as booths for small areas or tools with a vacuum system.

Based on previous SLC actions by Lockheed Martin and Boeing on CCAFS, the 45th SW required each contractor to perform their own air quality assessment and obtain the applicable air permits with FDEP. Depending on the construction activities, launch vehicle, numbers of launches and materials required to support these activities, the potential requirements include:

- Obtaining a Construction Permit
- Obtaining an Operating Permit (Title V or non-Title V)
- Developing a Risk Management Plan (depending on hazardous materials stored)
- Addressing Aerospace NESHAP (CCAFS not major for HAPs currently)
- Addressing Asbestos NESHAP (Asbestos is not planned to be removed from any facilities at the recommended alternative site, SLC 40 as part of this proposed action)

The Programmatic Assessment for Reactivation/Reuse of 12 Space Launch Complexes on CCAFS, Florida”, prepared in 2005 (DIG-03-03), states that “Utilization of a launch system similar to the EELV will not result in significant air quality impacts”. The Falcon 1 and 9 Launch vehicles are considered similar but smaller compared to the EELVs described in the Programmatic EA.

4.5.1.5 Wet Tests and Vehicle Launches

Each launch is considered to be a discrete event that generates short-term impacts on the local air quality. Long-term effects resulting from the launches would not be expected because the launches are infrequent and the resulting emissions are rapidly dispersed and diluted by winds in the troposphere. After final systems checkout before each launch, there would be a mission rehearsal without propellants on board (dry) plus a mission rehearsal with propellants loaded on the vehicle (wet) to verify full launch readiness. It was assumed, under the worst-case scenario, that one wet test would be performed per launch. Annual emissions for the wet test and the actual launch of the vehicle are calculated in Appendix C of the Final EA for the Proposed Falcon Launch Program for Vandenberg AFB (18 January 2003), using the results of actual measurement of emission factors from the Falcon engine. Table 4.5-4 below summarized the results of these emission calculations; assumptions were doubled those emissions, as the estimates in the Final EA for Vandenberg AFB were based on six launches per year and the proposed Falcon Launch Program for CCAFS has 12 proposed launches per year. Therefore, for CCAFS twelve launches proposed per year, we doubled the estimated emissions for each wet test and launch vehicle pollutant. These would be the same whether for the proposed action or for the proposed two alternative launch sites on CCAFS.

Table 4.5 - 4
Emissions from Wet Tests and Vehicle Launches (tons per year)

Activity	VOCs	Nitrogen Oxides	Carbon Monoxide	Sulfur Oxides	PA°
Wet test of 12 Falcon Vehicles for CCAFS *Estimate 6 vehicles	0.00	0.00	38.16	0.00	0.00
Launch of 12 Falcon Vehicles	0.00	0.00	1,142.64	0.00	0.00

*Estimates in this table were “doubled” here to consider CCAFS proposed 12 launches and 12 wet tests per year, instead of the 6 launches and 6 wet tests proposed in the recent Vandenberg Falcon Launch Program Final EA. Wet Tests occur on the launch stand one test assumed per launch. Estimates of CO and other pollutants associated with the actual launches are temporary in nature and rapidly the majority likely occur above the lower atmosphere and downrange of the launch stand and site. Once again, Launch emissions are considered mobile source emissions and are not required to obtain air permits.

4.5.1.6 Pollutant Emissions from the Proposed Program

In 2005 CCAS prepared and submitted an application package for submission to FDEP for modification of the Title V Air Operating Permit (No. 0090005-007-AV) to place limitations on HAPs potential to emit (PTE) for the facility-wide emission sources. Effective 29 November 2005, HAPs maximum facility-wide combined HAPs emissions were limited to less than 24.5 TPY and any facility-wide single regulated HAP to less than 9.5 TPY (Potential to Emit) pursuant to FAC Rule 62-210.200. This modification is construction permit number 0090005-008-AC. Also, CCAFS follows and complies with Air Force Instructions such as (AFI) 32-7040 for tracking and estimating air emissions estimates from point, area, and mobile sources for inclusion in the Title V Air Emissions Inventory.

The blast media usage is tracked, so it is assumed here that the data would be included in annual title V emission inventory updates each year as it has been in the past (Spectra, 2006).

Related to HAPs emissions, for a facility to be considered a major source of HAPs, it must have the potential to emit more than 25 TPY of a combination of the regulated 188 listed HAPs (CAAA of 1990), or have the potential to emit more than 10 TPY of any one regulated listed HAP. Table ES-01 of the CCAFS 2005 Air Emissions Inventory lists actual HAPs as 7.65 TPY and potential HAPs as 18.35 TPY. HAPs emissions from vehicle use during minimal construction and from routine traffic or equipment at the proposed action site, HAPs from fuel loading, and HAPs from launch mobile emissions would not increase the HAPs actual or potential annual emissions beyond the 25 TPY combined HAPs nor the 10TPY individual HAPs thresholds amounts to require a Title V permit modification to regulate CCAFS again as a “major” HAPs source under Title V.

For this program potential criteria air emissions such as VOCs and Particulates may result from various activities at the “Proposed Action” site or at Alternative 2, including launch stand refurbishment emissions, vehicle/equipment use mobile emissions and area emissions related to minimal construction, surface coating of launch stand, both initial and periodic maintenance, either abrasive blasting, hand sanding, or touch-up painting, resurfacing of site roads or parking areas, routine use vehicle traffic emissions during routine operations. Listed HAPs emissions would also be expected to occur from

vehicle gasoline fuel burning and particulates from diesel fuel burning and abrasive blasting. Numbers and duration of PM, VOCs, and HAPs type emissions are not expected to significantly increase the existing emissions estimates on CCAFS. Abrasive Blast Yard No. 3 if planned to be utilized may require a title V Air Permit modification as that yard is inactive, but is still listed on the current title V Air Operating permit.

Potential air emissions from the proposed launches would include activities related to liquid fuel loading (LOX and RP-1) and projected numbers of maximum launches. Air Permits are not required for emissions from the actual launches, as these are mobile sources and are temporary in nature, and therefore not considered to be “significant” or major emissions, neither for criteria nor HAPs pollutants. That storage tank capacity throughput rate for the AST that is designated for storage of RP-1 (and is presently located on SLC 36) is currently permitted for a maximum of 336,000 gallons of jet kerosene (RP-1) per consecutive 12 months. It is expected from the fuel estimates calculated that this proposed action would not result in an increase from the 2005 actual throughput rate which was 0 gallons for 2005 (SPECPRO, 2006). The tank, though “inactive” has been left on the current Title V Air Operating Permit and also the NSPS permit is still in place.

All of the types of emissions described for this proposed program are exempt from air permitting requirements at CCAFS pursuant to FAC Rule 62-210.300(3)(a), Categorical Exemptions, although these type emissions are required to be estimated and would be included in the next Title V Air Emissions Inventory Update for the CCAFS facility-wide emissions estimations. These types of categorically excluded emissions units or activities are considered to produce “insignificant” emissions pursuant to FAC Rule 62-213.430(6). The liquid fuel loading operations on CCAFS are included as categorically excluded from air permitting and are considered to be insignificant sources of air pollution by the FDEP.

4.5.1.7 PM 2.5 Ambient and Emissions Standards

On March 29, 2007, the EPA issued a rule defining requirements for state plans to clean air in areas with levels of fine particle pollution that do not meet national air quality standards. Earlier, in 1997 the EPA first established air quality standards for fine particles PM 2.5 (particles 2.5 micrometers in diameter and smaller) After enough monitoring data was collected by state, local and tribal governments, the EPA designated areas as “attainment or “nonattainment for PM2.5 standards, which became effective in April 2005. Those areas and or states which have been designated “nonattainment” are subject to significant additional air quality and particulate (PM2.5) standards and requirements. Florida and CCAFS have been designated as “attainment” areas. Current practices at CCAFS and by tenants such as SpaceX comply with existing fine particle (PM2.5) standards. The EPA is currently developing ambient standards for attainment areas; emission factor development and emissions estimates for PM2.5 is also underdevelopment. Latest EPA guidance and policy is to use PM10 emission factors as a “surrogate” for PM2.5 emissions estimates.

Consequently, the operation and launch of the Falcon 1 and 9 launch vehicle program will not have an appreciable affect on PM2.5 standards under the current “attainment” status of CCAFS.

4.5.2 Alternative 1 - SLCs 36 A and 36 B

Short term, on-going, and long term impacts to air quality are similar to those listed under the proposed action for SLC 40, although for both SLC 36 and for SLC 47 more facility upgrades and/or demolition may be required than for SLC 40. Emissions from loading and fueling would be no different than for any of the proposed action site or the other sites proposed as alternatives. Short term or long term cumulative

impacts to air quality would not be considered significant.

4.5.3 Alternative 2 - SLC 47.

Siting the Falcon 1 and 9 launch program at SLC 47 would require approximately 40 acres of undeveloped land to be disturbed and cleared. This would produce additional construction/land clearing fugitive dust, that would include PM and PM10, at a rate estimated at 1,700 pounds per acre or 17,000 pounds PM (8.5 tons PM). Of the particulates produced, PM10 would be estimated to be produced from that 10 acres land clearing, to be 7,650 pounds PM10 (3.83 Tons PM10). For other "Construction" related activities at CCAFS for calendar year 2005 it was estimated that a maximum of 55 acres would be disturbed each year to be included in the emissions inventory for the current Title V air permit. This estimate to the Title V emissions inventory included acreage demolished, site preparation, general construction, as well as projection of future potential "construction" projects. (Table 4.02-1, CCAFS 2004 Air Emissions Inventory). Emissions from these activities are primarily PM2.5 and PM10 and for these estimates in the inventory the actual emissions estimate and the potential emissions estimates are identical. PM2.5 emissions for the 2005 emissions inventory were 198 TPY and PM10 emissions were estimated to be 89.1 TPY.

4.5.4 No-Action Alternative

Under the No-Action Alternative, no changes to the air quality are proposed, and no refurbishment, construction, activity would occur; therefore, no impacts to air quality are expected, either short term, long term, on-going, or cumulative.

4.5.5 Cumulative Impact Reductions

4.5.5.1 Operations and Launch Activities

The Falcon Launch Vehicle Program is designed for minimal vehicle assembly or processing on the launch pad, with most of the vehicle assembly taking place at proposed SpaceX facilities at CCAFS. Because the atmospheric emissions associated with launch programs is expected to be brief and sporadic, the long-term cumulative air quality impacts in the lower atmosphere would not be expected to be significant. Short-term cumulative air quality impacts would not occur because launches for the various programs would not be conducted at the same time. The relatively small emissions associated with ground support operations would have little incremental and cumulative impact in an area that presently meets air quality standards.

4.5.5.2 Construction and Refurbishment Activities

Dust from refurbishment and limited site prep or restoration and construction activities should have minimal short term impact on local communities either on or off site, based on the assumption that the dust from refurbishment would be periodic and disperse relatively quickly. Exposure to nuisance dust above permissible exposure limits (established occupational health and safety standards) would be possible but unlikely (based on historical and expected construction activities). Mitigation of any dust could be accomplished through periodic site dewatering. No long term adverse air impacts are expected from refurbishment activities.

If exceedance of exposure limit is established for Alternative 2 (SLC 47) site due to short term

construction activities, health and safety procedures would need to be implemented by the contractor(s) to minimize emissions or exposure to dust (e.g., respirator protection, limit access to working zones) and to maintain compliance with OSHA requirements. Environmental regulations may require use of wetting agents applied to road surfaces to minimize PM_{2.5} and PM₁₀ fugitive dust emissions periodically. With this mitigation no adverse air quality impacts are to be expected.

4.6 ORBITAL DEBRIS

4.6.1 Falcon Orbital and Reentry Debris

This section describes the potential effects of orbital debris from either implementation of the Proposed Action, the Alternatives to the Proposed Action or the No-Action Alternative. However, since this section addresses post-launch aspects of the Falcon spacecraft program, this discussion applies equally to SLC 40, SCLs 36A and 36B and SLC 47. Orbital debris, as a result of U.S. and foreign space activities, may reenter the Earth's atmosphere. NASA's policy is to employ design and operations practices that limit the generation of orbital debris, consistent with mission requirements and cost-effectiveness. NASA Safety Standard (NSS) 1740.14 "Guidelines and Assessment Procedures for Limiting Orbital Debris" requires that each program or project conduct a formal assessment for the potential to generate orbital debris. General methods to accomplish this policy include:

- Depleting on-board energy sources after completion of mission,
- Limiting orbit lifetime after mission completion to 25 years or maneuvering to a disposal orbit,
- Limiting the generation of debris associated with normal space operations,
- Limiting the consequences of impact with existing orbital debris or meteoroids,
- Limiting the risk from space system components surviving reentry as a result of post-mission disposal, and
- Limiting the size of debris that survives reentry.

The routine payloads, including the Falcon spacecrafts and the Dragon would comply with all requirements of NPD 8710.3, "Policy for Limiting Orbital Debris Generation" and NSS 1740.14. A debris assessment would be prepared as required by this policy.

If a malfunction causes an unplanned reentry of the spacecraft during launch, pieces of the spacecraft could survive reentry and impact the ground. Impact of these pieces could produce injuries or fatalities. Over the period 1958 to 1991, NASA reported that 14,831 payloads and debris objects reentered the atmosphere (NASA 1991). There have been no reports of injuries or fatalities from reentering objects. The potential for collision between routine payload spacecraft and another spacecraft or orbital debris is also a concern. The chance of a collision between a typical spacecraft (10 m² or 108 ft² cross-sectional area) and a large debris object is estimated at 0.1 percent over its 10- year functional lifetime. This is greater than the risk of impacts with large-sized meteoroids (NRC, 1995).

Environmental and safety impacts resulting from the normal and errant burnout of launch vehicle stages would be controlled at CCAFS in accordance with AFSPC 91-710. That document requires that a trajectory analysis predict the instantaneous surface impact point (IIP) at any moment during launch for either normal flight or debris from a flight

terminated by range safety action. This IIP would be overlaid on range maps indicating populated or environmentally sensitive areas, and a launch corridor would be developed. This package of data, called the PFDP and discussed in Section 2, is developed for each mission (launch) well in advance of the launch activity. During the actual launch of the Falcon vehicles, tracking data and IIP plots would be monitored to assure the launch trajectory stays within the corridor. If a flight approaches corridor limits, it would be destroyed by Range Safety. This assures that spent stages or debris would only impact broad ocean areas cleared of shipping or air traffic. In rare cases, over-flight of land areas might be permitted if population density reduces the potential for human injury to less than 30×10^{-6} .

4.6.2 Falcon Launch Vehicle Impacts

Lower stages of the Falcon would burn out and impact in the open ocean. Upper stages that achieve Low Earth Orbit (LEO) would be programmed after spacecraft separation to burn residual propellants to depletion in a vector that would result in reentry in two to three months for a soft water landing as previously discussed. Upper stages going to higher orbits are not subject to controlled reentry and contribute to orbital debris. Their location would be tracked to permit avoidance with future launch trajectories. However, the accumulation of such debris is of international concern and is the subject of international study. Typical measures discussed to assist in reducing debris include designing vehicles that are "litter free" whereby appendages or attachments do not separate into additional pieces, and designing vehicles with material which is more resilient to breakup (USAF 1998)

Based on the preceding discussion, the launch of Falcon 1 and Falcon 9 vehicles and space craft, and their potential addition to, or affects from orbital debris is not expected to have a significant impact on the environment.

4.7 HAZARDOUS MATERIALS/HAZARDOUS WASTE

This section discusses hazardous materials/hazardous waste related to the implementation of either the Proposed Action or any of the alternatives and if it impacts the environment.

4.7.1 Proposed Action SLC 40

All hazardous materials would be handled and disposed of per the requirements established by OSHA (Hazardous Materials) and per the Hazardous Materials Contingency Plan developed for the Falcon Launch Vehicle Program. SpaceX is responsible for completing all Emergency Planning and Community Right-to-Know-Act (EPCRA) annual reporting requirements to the State and EPA as defined under SARA Title III. In the event of a spill, SpaceX would also be responsible for completing all State and EPA notifications if the spill/release exceeds reporting thresholds. In addition, a SPCC Plan would be prepared and kept onsite for the ASTs for RP-1, LOX, liquid nitrogen, and gaseous helium. Finally, any hypergolics associated with payloads (usually integral to a payload package) would be processed at an approved payload processing facility such as those operated by Astrotech or CCAFS, and once present at SLC-40; SpaceX would implement proper handling procedures for payloads containing hypergolics. Because all applicable federal, state, county, and Air Force rules and regulations would be followed for the proper storage, handling, and usage of hazardous materials under the Falcon Launch Vehicle Program, less than significant impacts on hazardous materials management should occur under the Proposed Action.

SpaceX would prepare an Emergency Response Plan for the Falcon Launch Vehicle Program in compliance with the CCAFS Hazardous Materials Emergency Response Plan to ensure that proper

response in the event of a spill of hazardous materials. In addition, in the event of a spill, SpaceX would also complete an EPCRA reporting form if amounts exceed the required reporting thresholds. Because all applicable federal, state, county, and Air Force rules and regulations would be followed for the proper response to an accidental spill of hazardous materials under the Falcon Launch Vehicle Program, less than significant impacts on hazardous materials emergency response would be generated under the Proposed Action.

4.7.1.1 Spacecraft (Dragon Capsule) Processing Use of Hazardous Materials

The approximate quantities of materials that would be used during processing of a routine payload spacecraft are listed in Table 4.7-1. Any materials remaining after completion of processing would be properly stored for future use or disposed of in accordance with all applicable regulations.

T a b l e 4 . 7 - 1
Payload Processing Materials of a Routine Payload Spacecraft

Material	Quantity	Purpose
Isopropyl Alcohol	22.7 liter (5 gal)	Wash
Denatured Alcohol	22.7 liter (5 gal)	Wash
Ink, White	0.5 liter (1 pt)	Marking
Ink, Black	0.5 liter (1 pt)	Marking
Epoxy adhesive	4.5 liter (1 gal)	Part bonding
Epoxy, Resin	4.5 liter (1 gal)	Repairs
Acetone	4.5 liter (1 gal)	Epoxy cleanup
Paint, Enamel	4.5 liter (1 gal)	Repair & marking
Paint, Lacquer	4.5 liter (1 gal)	Repair & marking
Mineral Spirits	4.5 liter (1 gal)	Enamel thinner
Lacquer Thinner	4.5 liter (1 gal)	Thinning lacquer
Lubricant, Synthetic	0.5 liter (1 pt)	Mechanism lube
Flux, Solder, MA	0.5 liter (1 pt)	Electronics
Flux, Solder, RA	0.5 liter (1 pt)	Electronics
Chromate conversion coating	0.5 liter (1 pt)	Metal Passivation

Source: NASA, 1998

Liquid hypergolic propellants make up the largest proportion of hazardous materials used in processing NASA routine payload spacecraft. A maximum of 1000 kg (2200 lb) of hydrazine (N₂H₄), 1000 kg (2200 lb) of monomethylhydrazine (MMH), and 1200 kg (2640 lb) of nitrogen tetroxide (NTO) could be loaded onto routine payload spacecraft (NASA 2002). The Falcon 9 orbital spacecraft Dragon would contain fewer quantities of these fuels. An additional quantity of each propellant could be present at the processing facility. As described in Sections 3.7, these propellants are extremely hazardous and toxic. They are transported and controlled by the base propellant contractor. They are not stored at the payload processing facilities. Facilities such as the SMARF and the proposed Combined Vehicle Assembly and Payload Processing Facility at

SLC 40 would need to be permitted to process hypergolic propellants and would be configured to manage hypergolic propellants and waste products.

4.7.1.2 Spacecraft (Dragon Capsule) Processing Hazardous Waste Production

The hazardous materials used to process routine payload spacecraft could potentially generate hazardous waste. SpaceX would be responsible for identifying, containing, labeling, and accumulating the hazardous wastes in accordance with all applicable Federal, State, and local regulations. These regulations are described in Section 3.7.

Liquid wastes would be generated almost exclusively from fuel and oxidizer transfer operations. Transfer equipment and lines would be flushed, first with potable water and then with an isopropyl alcohol (IPA) and demineralized water mixture. After MMH has been loaded, equipment and lines used to transfer MMH would also undergo potable water flushes followed by an isopropyl alcohol (IPA)/demineralized water flush. Similarly, potable water would be used to flush oxidizer transfer equipment and lines after NTO has been transferred to the satellite. The rinses resulting from the first three flushes of potable water for MMH and NTO lines and equipment are considered hazardous waste. Further flushes with IPA and demineralized water may or may not be hazardous waste depending on the waste characterization. Approximately 23 liters (5 gallons) of sodium hydroxide solution used for soaking small oxidizer transfer equipment parts (e.g., seals and fittings) would be added to the oxidizer rinse water. All five rinse-water waste streams would be collected in separate, Department of Transportation (DOT)-approved containers. The containers would be placed in the waste propellant area (satellite accumulation points) outside the facility until retrieved by the base contractor (NASA, 2002).

The fuel and oxidizer rinse-water wastes may or may not be hazardous depending on how the waste was generated and/or the characteristics of the wastes. Waste from each drum would be sampled and characterized based on laboratory analysis and the generation process. Based on the results of the waste characterization, drums would be labeled as hazardous or non-hazardous and disposed of according to applicable regulations (NASA, 2002).

The sodium hydroxide solution used in the oxidizer scrubber would be changed about once every five to ten years. The base contractor would pump the spent solution into approved containers, and then dispose of the waste according to its tested characteristics. The citric acid solution used in the fuel scrubber would be collected and disposed of by SpaceX or a contractor as non-hazardous waste.

During gaseous nitrogen purging of equipment and lines used to transfer anhydrous hydrazine and MMH to the satellite, a liquid separator would collect liquid droplets remaining in the equipment as the air streams pass through the hypergolic vent scrubber system. Prior to loading with NTO, approximately 23 liters (5 gallons) of a mixture of hydrazine and MMH would be transferred from the liquid separator to an approved container. The container would be placed in the waste propellant area outside the facility until retrieved by the base propellant contractor (NASA, 2002).

Solid hazardous wastes would also be generated almost exclusively from fuel and oxidizer transfer operations. Solids such as rags coming into contact with a fuel or oxidizer would be double-bagged and placed in a DOT-approved container. A separate container would be used for each fuel or oxidizer. Containers would be labeled as hazardous waste and accumulated in the waste fuel and oxidizer areas until collected by SpaceX personnel or the base contractor. Because solids contaminated with MMH and NTO are acutely toxic hazardous waste, these containers would be moved to a 90-day waste accumulation facility within 72 hours if amounts exceed 1.1 liter (1 quart). Processing of routine

payload spacecraft would increase hazardous waste production at the launch sites by very small percentages (NASA 2002).

4.7.1.3 Falcon 1 and 9 Launch Vehicle Impacts

The processing of launch vehicles at the launch site requires the use of hazardous materials. It also results in the production of hazardous waste. The Titan IV is used as an example of hazardous materials usage and hazardous waste generation by a launch vehicle system since it is a large vehicle with solid rocket motors (SRMs) launched from SLC 40 and is much larger than either the Falcon 1 or Falcon 9 Table 4.7-2 lists the estimated amounts of hazardous materials to be used per launch for the Titan series or Atlas vehicle with SRMs.

T a b l e 4 . 7 - 2
Hazardous Materials Used per Titan IV and Atlas V Launches

Material	Quantity	Purpose
Petroleum, oil, lubricants	2177 kg (4790 lb)	Booster Processing
VOC-based primers, topcoats, coatings	145 kg (320 lb)	External maintenance
Non-VOC based primers, topcoats, coatings	86 kg (190 lb)	External maintenance
VOC-based solvents, cleaners	627 kg (1380 lb)	Surface cleaning
Non VOC-based solvents, cleaners	432 kg (950 lb)	Surface cleaning
Corrosives	2500 kg (5500 lb)	Surface preparation
Adhesives, sealants	1036 kg (2280 lb)	Structural, electronic
Other	291 kg (640 lb)	Booster processing
Electron QED cleaner	5.7 liter (5 qt)	SRM cleaning
MIL-P-23377 primer	2.8 liter (5 pt)	SRM exterior
Silicone RTV-88	45 liter (10 gal)	SRM sealant
Electric insulating enamel	0.1 kg (5 oz)	SRM touchup
Acrylic primer	22 liter (5 gal)	SRM touchup
Conductive paint	45 liter (10 gal)	SRM antistatic coating
Chemical conversion coating	0.3 kg (10 oz)	SRM surface preparation
Cork-filled potting compound	5.7 liter (5 qt)	SRM thermal protection
Epoxy adhesive	5.7 liter (5 qt)	SRM modification

Derived from USAF, 2000a to illustrate quantities associated with Atlas V 500 and Titan IV SRMs.

Launch deluge wastewater generated by the Proposed Action would normally be categorized as industrial wastewater; however, this wastewater would be characterized to ensure that it would not be considered a hazardous waste. If so, it would be properly handled and disposed of, typically pumped into a wastewater removal truck from the deluge water holding area on-site and either transported to the WWTP on CCAFS or transported off base to the appropriate hazardous waste treatment disposal sites currently utilized in Florida by CCAFS.

Because all applicable rules and regulations regarding hazardous waste (RCRA and non-RCRA) storage, treatment, and disposal, and associated reporting requirements, would be adhered to under the Proposed Action, less than significant impacts on hazardous waste management would occur under operation of the Falcon Launch Vehicle Program. In addition, hazardous waste streams anticipated to be generated by the Falcon Launch Vehicle Program are typical of other hazardous waste streams in Florida. Therefore, the existing hazardous waste, landfills would have sufficient capacity to handle the small amounts of hazardous waste expected to be generated under the Proposed Action. SpaceX would prepare a SPCC Plan pursuant to state and federal regulations for the aboveground storage tanks (ASTs) for LOX, RP-1, liquid nitrogen, and gaseous helium. Finally, SpaceX would determine if the current NSPS and Title V operating permit for the permitted AST for RP-1 on CCAFS permit would require a modification due to the increase in RP-1 proposed (see section on air quality in chapter 3).

4.7.1.4 Pollution Prevention

No Class I ozone-depleting substances (ODSs) would be used in the payload processing facilities. Small quantities of materials that contain EPA-17 targeted industrial toxic materials may be used during spacecraft processing. These include coatings and thinners that typically contain toluene and xylene. Toluene and xylene are also listed chemicals under the Emergency Planning and Community Right-to-Know Act (EPCRA) Section 313. SpaceX payload processing personnel would track usage of all EPCRA-listed chemicals and report emissions to the responsible government organization at CCAFS.

All routine payload spacecraft processing activities would be in compliance with the CCAFS Pollution Prevention Management Plan (PPMP). This compliance would minimize pollution and meet the regulatory requirements relative to pollution prevention as described in Sec. 3.7. Processing of routine payload spacecraft would not substantially affect the ability of CCAFS, to achieve pollution prevention goals.

4.7.1.5 Installation Restoration Program

Normal operation would not generate impacts on the proposed action, SWMU C046 (SLC 40), the preferred alternative 1, SWMU C050 (SLC 36), or Preferred Alternative 2, SLC 47. In addition, operation would not impact ongoing investigations at either the proposed action site or at the preferred alternative sites. Normal operation would not negatively impact ongoing investigations at SLC 40 or SLC 36.

In the event of a launch mishap, IRP sites nearby within the vicinity of SLC 40, 36, or 47 could be affected by debris. However, it should be noted that the probability of a launch mishap occurring is extremely low, and if one occurred, the probability of debris landing at these sites or any one specific site is also low. Therefore, impacts on these or other nearby IRP sites in the event of a launch mishap would be less than significant.

4.7.1.6 Construction and Refurbishment Impacts Hazardous Materials

All hazardous materials used and waste generated during refurbishment activities associated with the Proposed Action would be handled, transported, treated, and disposed of in accordance with the Hazardous Materials Contingency Plan and Hazardous Waste Management Plan prepared by SpaceX for the Falcon Launch Vehicle Program. Hazardous materials used for refurbishment activities would include diesel fuel, oil, paint, solvents, and other materials typically used to run and maintain heavy equipment. If an inadvertent release of oil or hazardous materials occurs during refurbishment, the response would follow the Emergency Response Plan developed for the Falcon Launch Vehicle Program.

4.7.2 Alternative 1 – SLCs 36 A and 36 B

Operation Impacts

Under the Proposed Action and Alternative 1, launch deluge wastewater would also be generated. Therefore, impacts on hazardous materials and hazardous waste management generated by the operation of Preferred Alternative 1 would be the same as for those generated by the Proposed Action. If the deluge wastewater is characterized as hazardous after testing, it would also be disposed of in a way similar to that described in 4.7.1.3. All other impacts on hazardous materials and hazardous waste management would be identical or less than for the Proposed Action, though metals in the soils would not be a concern for Alternative 1 (SLC 36) or for Alternative 2 (SLC 47). Therefore, less than significant impacts on hazardous materials or hazardous waste management would occur under operation of Alternative 1 (SLC 36).

Refurbishment Impacts

Impacts on hazardous materials and hazardous waste management generated during the refurbishment activities of Alternative 1 would be identical to those of the Proposed Action and would, therefore, be less than significant.

4.7.3 Alternative 2 – SLC 47

There would not be refurbishment impacts, but rather construction associated hazardous waste impacts. However the construction activities would be temporary in nature and, therefore, not considered to produce significant impacts with regard to construction. Once all facilities were built, impacts on the environment would be similar to SLCs 36 A and 36 B and SLC 40.

4.7.4 No-Action Alternative

Under the No-Action Alternative, the Falcon Launch Vehicle Program would not be implemented; therefore, no impacts on hazardous materials or hazardous waste management would be generated.

4.8 WATER RESOURCES

This section describes the potential effects to surface water and groundwater, including hydrology, water quality, wetlands and floodplains, resulting from either implementation of the Proposed Action, the Alternative to the Proposed Action or the No-Action Alternative. There would be no long-term effects on water resources as a result of implementation of the Proposed Action or Alternative to the Proposed Action.

4.8.1 Proposed Action – SLC 40

This section describes the potential impacts to water resources through the reuse/reactivation of SLC 40 or the SMARF. The existing surface drainage patterns at SLC 40 would be altered if any excavation and/or grading and the creation of impervious surfaces occurred. The site has been previously disturbed, so natural drainage patterns no longer exist. The planned design and construction of the Vehicle assembly building and Payload Processing Facility (hanger) at SLC 40 would not substantially alter the existing drainage course, and adverse impacts to natural drainages are not anticipated, especially if located in the northeast quadrant of SLC 40. If the southern location is chosen for the large hanger, existing drainage

swales will have to be reviewed and redesigned . Impacts from erosion, and specific measures to control both wind and water erosion of soils during and after construction, would be taken care of by developing a Stormwater Erosion and Pollution Prevention Plan (SWPPP).

Because the disturbed area is greater than 1 acre, a NPDES Storm Water Construction Permit would be required by FDEP and a SWPPP would be implemented. An Environmental Resource Permit would also be required by SJRWMD for any activity that meets the requirements listed in Rule 40C, F.A.C. Additionally, 45 SW personnel would review the design drawings for all construction-related projects. This process ensures that the design is in compliance with current and applicable storm water and wastewater regulations.

It is not expected that reusing/reactivating SLC 40 and the SMARF for the Falcon launch program would disturb wetlands or affect any floodplains. Figures 3.3-1 and 3.3-5 identifies the location of wetlands and floodplains in and around SLC 40 and the SMARF respectively. No wetlands or floodplains occur within the boundary of SLC 40 or the SMARF, but do occur within 300 feet of the boundary.

Under the Proposed Action, launch deluge wastewater generated by both testing and launch operations would be contained in the deluge (impermeable concrete) basin and removed and hauled to an approved off-base disposal facility. Therefore, no impacts on surface water quality would occur from industrial wastewater from the deluge water system.

Operation of the Proposed Action has the potential to cause inadvertent discharge of industrial wastewater (deluge water) into jurisdictional waters of the United States in the event of an overflow of the deluge water system deluge basin, due to their proximity to the retention basin. However, with the deluge basin capacity of approximately 400,000 gallons, it is highly unlikely that the maximum 8,000-gallon discharge of deluge wastewater would be inadvertently discharged from the basin. Therefore, less than significant impacts on jurisdictional waters of the United States are expected under operation of the Proposed Action.

The intermittent drainage from SLC-40 could be affected by the exhaust cloud that would form near the launch pad at liftoff as a result of the exhaust plume and evaporation and subsequent condensation of deluge water. Because the Falcon launch vehicles use only LOX and RP-1 propellants, the exhaust cloud would consist of steam only and would not consist of any significant amounts of hazardous materials. As the volume of water condensing from the exhaust cloud is expected to be minimal and temporary, the exhaust cloud would generate less than significant impacts on surface water quality at SLC-40.

Upon impact with the ocean of the first stage, approximately 5 gallons of residual RP-1 would be expelled into the ocean and would dissipate within hours. Due to the small volume of this release into the open ocean, impacts on water quality in the ocean would be less than significant.

4.8.1.1 Spacecraft Processing Impacts

There would be no impacts to water resources from spacecraft processing and or payload preparations with the exception of those items discussed in section 4.5.1.2 above. Processing activities would take place within either newly constructed structures or in a refurbished SMARF and precautions would be taken to prevent and control spills of hazardous materials. Large spills of spacecraft liquid propellant would be controlled through catchment systems in the processing facilities. Use of all chemicals involved in processing would be managed to prevent contamination of surface waters and groundwater.

The typical operation of the facility proposed for use for routine payload processing would require an average of approximately 500 liters (110 gallons) per day of water for potable use and for payload processing activities (ASTROTECH, 1993). This water would be supplied by the existing water distribution systems at CCAFS and would have a negligible impact on system capacity or surface and groundwater resources. The total volume of wastewater generated by the facility has been estimated to average about 500 liters (110 gallons) per day (ASTROTECH, 1993). This wastewater would be processed through the existing wastewater handling and treatment systems at CCAFS, and would have a negligible impact on system capacity or surface and groundwater resources. The proposed action fits within the current scope of water discharge permit definitions. Local and regional water resources would not be affected since there would be no substantial increase in use of surface or groundwater supplies.

4.8.2 Alternative 1 – SLCs 36 A and 36 B

This section describes the potential impacts to water resources through the reuse/reactivation of SLCs 36A and 36B. The impacts would be the same as those described under Section 4.8.1 except that wetlands are located within both 36A and 36B SLC boundaries. Figures 3.3-2 and 3.3-3 depict the wetlands and floodplains in relation to the SLC boundaries. However SpaceX construction plans would include facility designs that would not affect the existing wetlands. The planned, large vehicle assembly facility (hanger) would be placed inside the boundary fence in previously disturbed areas. Therefore no adverse impacts to water resources are expected. Standard construction practices and adherence to permit requirements and applicable regulations would minimize impacts to water resources.

4.8.3 Alternative 2 – SLC 47

This section describes the potential impacts to water resources through the construction of a new SLC. The existing surface drainage patterns at the new proposed SLC location would be altered significantly through excavation, grading, and the creation of impervious surfaces. This site has been minimally disturbed previously, and adverse impacts to natural drainages are anticipated. Impacts from erosion, and specific measures to control both wind and water erosion of soils during and after construction, would need to be addressed within a developed SWPPP.

The disturbed area would be between 10 and 40 acres; therefore a NPDES Storm Water Construction Permit would be required by FDEP and a SWPPP would be implemented. An Environmental Resource Permit would also be required by SJRWMD for any activity that meets the requirements listed in Rule 40C, F.A.C. Additionally, 45th SW personnel would review the design drawings for all construction-related projects. This process ensures that the design is in compliance with current and applicable storm water and wastewater regulations.

Construction of a new SLC in the location identified on Figure 3.3-4 would most likely require roadway construction work to move Phillips Parkway further to the west. Relocating Phillips Parkway will place it directly adjacent to wetlands and floodplains. However at this time it does not appear that the wetlands would be impacted.

4.8.4 No-Action Alternative

Under the No-Action Alternative, no changes to the hydrology or water quality are proposed, and no construction or modification of facilities would occur; therefore, no impacts to hydrology or water quality are expected.

4.8.5 Cumulative Impacts

Since construction, refurbishment, or launch operations for the Falcon 1 and 9 launch vehicle programs would occur separately there are no cumulative impacts.

It is not expected that construction at SLC 40 would impact wetlands; therefore mitigation would not be required. Construction at SLCs 36A or 36B or SLC47 instead of SLC 40 would be planned to avoid any impact to adjacent wetlands.

4.9 GEOLOGY AND SOILS

This section addresses any potential geologic impact of the Proposed Action, and the two alternatives to, foundation instability, land subsidence, or other geologic aspects of the areas in and around existing SLC 40, 36A, 36B, or SLC 47.

4.9.1 Proposed Action - SLC 40

No unique geologic features of exceptional interest or mineral resources occur in the project area; therefore, no impacts would occur to these resources. Operation of the Proposed Action would not affect geology or soils at or near SLC 40. Refurbishment activities at SLC 40 or the SMARF would not affect geology or soils. Construction activities at SLC 40 to build the combined vehicle assembly and payload processing facility would disturb soils and increase the potential for wind and water erosion. However the development and implementation of a Storm Water Pollution Prevention Plan (SWPPP) in accordance with NPDES guidance would specify methods to control both types of erosion. Therefore, no significant impacts on these resources would occur under operation of the Proposed Action.

4.9.2 Alternative 1 - SLCs 36 A and 36 B

Impacts on geology and soils generated during the operation of Alternative 1 would be identical to those generated by operation of the Proposed Action; therefore, no impacts would occur. Impacts on geology and soils generated during the refurbishment or construction activities of Alternative 1 would be identical to those of the Proposed Action, and would therefore be less than significant.

4.9.3 Alternative 2 - SLC 47

Impacts on geology and soils generated during the operation of Alternative 2 would be identical to those generated by operation of the Proposed Action; therefore, no impacts would occur. Impacts on geology and soils generated during the construction activities required to establish this location as suitable launch facility for the Falcon 1 and Falcon 9 vehicles would be greater than either the Proposed Action or Alternative 1. Up to 40 acres of currently undisturbed land would require site work. Facility foundations and site leveling may affect the topography and therefore the storm water run-off patterns and increase the potential for wind and water erosion. However the development and implementation of a Storm Water Pollution Prevention Plan (SWPPP) in accordance with NPDES guidance would specify methods to reduce both types of erosion. Short-term adverse impact to soils would be likely, but standard construction practices and adherence to NPDES permit requirements would minimize any adverse impacts. Impacts however would be expected to be less than significant.

4.9.4 No-Action Alternative

Under the No-Action Alternative, the Falcon Launch Vehicle Program would not be implemented; therefore, no operational or refurbishment impacts on geology and soils would occur.

4.10 TRANSPORTATION

The following section discusses the projected traffic conditions along roadways affected during the refurbishment and operation of the Falcon Launch Vehicle Program. Operation and refurbishment impacts on transportation due to the commute of refurbishment workers and SpaceX personnel, shipment of Falcon components, delivery truck trips to and from SLC-40, and railroad traffic, are discussed below. A brief discussion of added traffic volume during scheduled launches is also included.

4.10.1 Proposed Action – SLC 40

4.10.1.1 Operation Impacts

Initial assembly of the first and second stages of the Falcon vehicles would occur at the SpaceX facility in El Segundo, California. Following assembly, the stages would be transported to CCAFS via the highway system. Payloads would be shipped via major arterials depending upon their origin. Shipment of these components to CCAFS would occur no more than 12 times a year; therefore, they would have a less than significant impact on traffic in the region. Hazardous materials and hazardous wastes transferred by the Falcon Launch Vehicle Program are in the same categories as those normally encountered in public transportation; their shipment over public highways and roads would be in compliance with Department of Transportation regulations.

During routine operations between launches, a maximum of ten SpaceX personnel would be stationed at CCAFS facilities or at SLC-40. During a launch campaign, between 12 and 15 people on average would be stationed at SLC-40 for a period of 4 to 8 weeks, with a maximum of 25 people for a 1-week period within this timeframe. In addition, up to eight trucks would visit SLC-40 approximately once a week, including a fuel truck, LOX truck, nitrogen truck, helium truck, a truck to deliver a crane, three delivery trucks, during a launch campaign (for a total of 64 vehicle trips per launch). Assuming the worst-case scenario, the addition of 25 personnel (or 25 daily vehicle trips) and eight delivery trucks (or two daily vehicle trips) traveling on key roadways within CCAFS areas would not constitute a significant increase in the traffic volumes on these roadways (a total addition of 105 daily vehicle trips during a launch). Vehicle trips per launch would be expected to be less than existed for a Titan IV launch. Therefore, operation of the Proposed Action would generate less than significant impacts on transportation.

4.10.1.2 Construction and Refurbishment Impacts

During the Proposed Action construction and refurbishment activities, 5 people, on average, would be at SLC-40 for a period of 3 to 5 months. A maximum of 15 people may be on-site at any one time during this timeframe. Assuming the worst-case scenario, an addition of 15 people (or 15 daily vehicle trips) traveling on key roadways within CCAFS would not constitute a significant increase in the traffic volumes on these roadways.

4.10.1.3 Launch Viewing related Traffic Impacts

A day preceding a scheduled launch day and the day of a launch CCAFS and surrounding areas tend to see an increase in traffic caused by the public's desire to observe a launch event. The amount of traffic volume increase is dependent upon a number of variables such as amount of prior publicity, importance, period of the week and even weather conditions and the chance for a delayed launch. The largest increase is typically experienced with a Shuttle launch near the weekend and with good weather. Much lower volume increases are experienced during minimally publicized events of non-Shuttle launches. In both cases area and base law enforcement is notified in advance of expected launches in anticipation of increased traffic flow. Traffic volume increases for a Falcon 1 or Falcon 9 launch is expected to be less than that of a Shuttle launch and closer to well publicized launches of recent Titan or Delta launches. Therefore impact from increase visitor or public observers will cause less than significant impact on CCAFS and local traffic patterns.

4.10.2 Alternative 1 - SLCs 36A and 36 B

Impacts on transportation generated during the operation of Alternative 1 would be identical to those of the Proposed Action, and would, therefore, be less than significant. Impacts on transportation generated during the refurbishment activities of Alternative 1 would be identical to those of the Proposed Action, and would, therefore, be less than significant.

4.10.3 Alternative 2 - SLC 47

Impacts on transportation generated during the operation of Alternative 2 would be identical to those of the Proposed Action, and would, therefore, be less than significant. Impacts on transportation generated during the refurbishment activities of Alternative 2 would be identical to those of the Proposed Action, and would, therefore, be less than significant.

4.10.4 No-Action Alternative

Under the No-Action Alternative, the Falcon Launch Vehicle Program would not be implemented; therefore, no operational or refurbishment impacts on transportation would occur.

4.11 UTILITIES

This section describes the potential effects to the water supply system, the solid waste management aspect, and the electrical supply system by implementing the proposed action, any alternatives, or No-Action Alternatives.

4.11.1 Proposed Action – SLC 40

Water Supply

Current potable and non-potable water supply to SLC 40 was designed to support a Titan IV launch vehicle program. Pump house number 7 (Facility #29150) supplies SLC 40 and SLC 41 with water for the deluge system. As such, the water supply to SLC 40 (Table 4.11-1 below) can easily handle either Falcon 1 or Falcon 9 launch requirements which do not exceed 100,000 gallons per launch. Since only one launch vehicle would be in a launch preparation of actual launch at any given point, Falcon program requirement on the water supply would be relatively small.

**Table 4.11-1
Pump Station #7 Capacity**

PARAMETER	CAPACITY / AMOUNT
Water Storage Tank	1,250,000 gallons
Diesel fuel tank for pumps	10,000 gallons
Deluge Pumps	6
Pump capacity	7500 Gallons per minute
Total pump capacity	45,000 Gallons per minute
LC40 Design Usage (Titan IV launch)	700K-800K per launch
Falcon required capacity	100K per launch
Water Line Pressure	210 psi

Operation of the Proposed Action is anticipated to generate minimal amounts of supply water requirements when compared to design availability and capacity. The Proposed Action, therefore, would generate less than significant impacts on water supply.

Solid Waste Management

Operation of the EELV Program was anticipated to generate approximately 0.3 ton of solid waste per day (U.S. Air Force 1998a). Operation of the Proposed Action is expected to generate less solid waste than the EELV Program. SpaceX would contract or perform in-house removal of solid waste to an off-base recycling or disposal facility. The amount of solid waste generated would be minimal, and largely consist of administrative and personal material such as paper, cans and bottles that would be recycled. Therefore, operation of the Proposed Action is anticipated to generate minimal amounts of solid waste compared with the capacity of the on-base or approved off-base landfills. The Proposed Action, therefore, would generate less than significant impacts on solid waste.

Construction and Refurbishment Impacts

Solid waste, including concrete and some scrap metal, would be generated during refurbishment. When feasible, solid waste would be recycled; if not recyclable, it would be disposed of at an existing off-base sanitary landfill permitted to accept the waste on at the landfill on CCAFS grounds. Construction and /or refurbishment actions are anticipated to generate minimal amounts of solid waste compared with the capacity of the Landfills. The Proposed Action would, therefore, generate less than significant impacts on solid waste.

Electrical Power

The electrical power capabilities for operation at SLC 40 and the SMARF were designed to support the Titan IV launch program. The Falcon 1 and Falcon 9 launch program electrical power needs are less than that of the Titan Program. Therefore there would not be a significant impact on available electrical power capabilities for the Proposed Action.

4.11.2 Alternative 1- SLCs 36A and 36B

Water Supply

Water supply impacts generated by the operation of Alternative 1 would be identical to those of the operation of the Proposed Action. While the available supply capacity of the deluge system is not as great, Falcon requirements would be less than significant.

Solid Waste Management

Solid waste impacts generated by the operation of Alternative 1 would be identical to those of the operation of the Proposed Action, and would, therefore, be less than significant. Solid waste impacts generated by refurbishment activities for Alternative 1 would be identical to those of the Proposed Action, and would, therefore, be less than significant.

Electrical Power

Electrical power impacts generated by the operation of Alternative 1 would be identical to those of the operation of the Proposed Action. Power demands at SLC 36A and B would not cause a significant impact on power availability.

4.11.3 Alternative 2 – SLC 47

Water Supply

Water supply impacts generated by the operation of Alternative 2 would be identical to those of the operation of the Proposed Action. However, at this time there is no such supply available to SLC 47 without constructing a new water supply facility. Therefore water supply impacts generated by activities for Alternative 2 would be significant.

Solid Waste Management

Solid waste impacts generated by the operation of Alternative 2 would be identical to those of the operation of the Proposed Action, and would, therefore, be less than significant. Solid waste impacts generated by refurbishment activities for Alternative 2 would be identical to those of the Proposed Action, and would, therefore, be less than significant.

Electrical Power

Electrical power impacts generated by the operation of Alternative 2 would be identical to those of the operation of the Proposed Action. However, construction of an electrical substation would be required to supply Power demands at SLC 47. Once constructed, there would not be a significant impact on power availability.

4.11.4 No-Action Alternative

Water Supply

Under the No-Action Alternative, the Falcon Vehicle Program would not be implemented; therefore, no operational or refurbishment impacts on water supply would occur.

Solid Waste Management

Under the No-Action Alternative, the Falcon Vehicle Program would not be implemented; therefore, no operational or refurbishment impacts on solid waste management would occur.

Electrical Power

Under the No-Action Alternative, the Falcon Vehicle Program would not be implemented; therefore, no operational or construction / refurbishment impacts would occur to the electrical power resource.

4.12 HEALTH AND SAFETY

This section addresses the health and safety of, and the involved the use, production, or disposal of materials that pose a hazard to people, animals, or plant populations in the affected area as a result of the proposed action or the two alternatives.

4.12.1 Proposed Action – SLC 40

As described in Section 3.12, CCAFS range safety regulations ensure that the general public, launch area personnel, and foreign land masses are provided an acceptable level of safety, and that all aspects of pre-launch and launch operations adhere to public laws. Range safety organizations review, approve, monitor, and impose safety holds, when necessary, on all pre-launch and launch operations.

All payload processing and launch facilities used to store, handle, or process ordnance items or propellants must have an Explosive Quantity-Distance Site Plan. All payload and launch programs that use toxic materials must have a Toxic Release Contingency Plan (TRCP) for facilities that use the materials. A Toxic Hazard Assessment (THA) must also be prepared for each facility that uses toxic propellants. The THA identifies the safety areas to be controlled during the storage, handling, and transfer of the toxic propellants.

Hazardous materials such as propellant, ordnance, chemicals, and booster/payload components are transported in accordance with DOT regulations for interstate shipment of hazardous substances (Title 49 CFR 100- 199). Hazardous materials such as liquid rocket propellant are transported in specially designed containers to reduce the potential of a mishap should an accident occur.

4.12.1.1 Spacecraft Processing Impacts

4.12.1.2 Hazardous and Toxic Propellants

Processing of routine payload spacecraft would involve the handling of toxic and hazardous propellants including hydrazine, MMH, and NTO. Hydrazine and MMH are strong irritants and may damage eyes and cause respiratory tract damage. Exposure to high vapor concentrations can cause convulsions and possibly death. Repeated exposures to lower concentrations may cause toxic damage to liver and kidneys as well as anemia. The U. S. Environmental Protection Agency (EPA) classifies hydrazine and MMH as probable human carcinogens. Both are flammable and could spontaneously ignite when exposed to an oxidizer. NTO is a corrosive oxidizing agent. Contact with the skin and eyes can result in severe burns. Inhalation of vapors can damage the respiratory system. NTO would ignite when combined with fuels and may promote ignition of other combustible materials. Fires involving NTO burn vigorously and produce toxic fumes.

Health and safety impacts to personnel involved in the propellant loading operations in the payload processing facilities would be minimized by adherence to U. S. Occupational Safety and Health Administration (OSHA) and U. S. Air Force Occupational Safety and Health (AFOSH) regulations. These regulations require use of appropriate protective clothing and breathing protection. Toxic vapor detectors are used in the facilities to monitor for leaks and unsafe atmospheres.

Spills, fires, and explosions would be possible outcomes from accidents during payload processing. A violent fire or an explosion could produce severe injuries or even death. A catastrophic accident of this type during payload processing would be extremely unlikely. Most propellant spills would be contained within the processing facility with no health impacts to personnel. The most likely consequences of a severe accident during processing would be some level of damage to the spacecraft and the immediate liquid propellant transfer area. Facility design would limit damage to the spacecraft and the transfer area.

Injuries would not be anticipated if facility personnel follow emergency procedures. If human error (e.g., not following procedures, not wearing protective clothing, or not donning breathing equipment) occurs at the time of the accident, exposure of personnel to toxic propellant vapors may result. This would give some level of short-term adverse health impact and an incremental increase in the chance of the exposed individual developing cancer.

Extremely small quantities of toxic propellant vapors would be emitted from payload processing facilities during propellant loading operations. These small emissions would not impact the health of the public or on-site personnel. The THA for the facility would provide additional protection by identifying the safety areas to be cleared of unprotected personnel during propellant operations.

4.12.1.3 Launch Vehicle Impacts

The Range Safety organizations at CCAFS use models to predict launch hazards to the public and on-site personnel prior to every launch. These models calculate the risk of injury resulting from toxic gases, debris, and blast overpressure both from both nominal launches and launch failures. Launches are postponed if predicted risk of injury exceeds acceptable limits. The allowable collective public risk limit in use at CCAFS is extremely low (30×10^{-6}).

Appendix C contains the Debris analysis for the Falcon 9 launch vehicle. The document determines the approximate number of possible fragments and their weight (or groups of similar fragments) that may result from launch vehicle destruction, under several modes, during the launch event. SpaceX would also develop a Preliminary Flight Data Package well in advance of each scheduled mission (launch) of the Falcon 1 or 9. The Data Package document, which has been developed for a planned initial launch, discussed launch trajectory and fall-out areas in depth. Current plans have trajectories that immediately head east over the Atlantic, and do not pass over land until it reaches Africa when it has just about completed its ascent. At that time it will be above sparsely populated areas for approximately 11 seconds. The first stage and fairing is expected to fall into the Atlantic several hundred miles east of the Florida coast.

The proposed action involves launch vehicles that have previously been approved for launch of spacecraft from CCAFS. This action would not increase launch rates nor utilize launch systems beyond the scope of approved programs at CCAFS.

4.12.1.4 Refurbishment Impacts

During refurbishment of the Proposed Alternative, SpaceX would comply with all federal OSHA regulations and all applicable Air Force Instructions and regulations on refurbishment safety, including AFT 32-1023, *Design and Refurbishment Standards and Execution of Facility Refurbishment Projects*, AFSPC 91-710 and Air Force Occupational Safety and Health Standards. Health and safety impacts generated during refurbishment would, therefore, be less than significant.

4.12.2 Alternative 1 - SLCs 36 A and 36 B

Health and safety impacts generated by refurbishment activities for Alternative 1 would be identical to those of the Proposed Action, and would therefore be less than significant.

4.12.3 Alternative 2 - SLC 47

Health and safety impacts generated by refurbishment activities for Alternative 2 would be identical to those of the Proposed Action, and would therefore be less than significant.

4.12.4 No-Action Alternative

Under the No-Action Alternative, the Falcon Launch Vehicle Program would not be implemented; therefore, no health and safety impacts would be generated.

4.13 SOCIOECONOMICS

This section discusses the socioeconomic impacts from implementation of either the proposed action or the two alternatives on the location and distribution of the local population, economic growth rates, the local housing market and the need for new social services and support facilities.

4.13.1 Proposed Action – SLC 40

During non-launch periods, operation of the Proposed Action would up to 10 workers at CCAFS offices or at SLC-40 facilities. During launch periods, operation of the Proposed Action would support an average of 12 to 15 people for 4 to 8 weeks, with a peak of 25 people occurring for a 1-week window during that timeframe. The addition of a maximum of 25 workers at CCAFS does not represent a significant increase in the population or growth rate of the region which is over 550,000 thousand people. The Proposed Action would not significantly affect the local housing market, and the addition of a maximum of 25 people would not result in the need for new social services or support facilities. Therefore, the Proposed Action would generate no negative socioeconomic impacts on the region.

4.13.1.2 Construction and Refurbishment Impacts

Construction and refurbishment activities for the Proposed Action would result in a temporary and minor increase in the number of on-base personnel. This increase would not represent a significant increase in the population or growth rate of the region, since most of the construction crew already live and work in the area. The local housing market would not be substantially affected, and no new social services or support facilities would be required. The Proposed Action may actually result in a minor increase

in the employment of the region, thus generating positive impacts. Therefore, construction and refurbishment activities of the Proposed Action would generate no negative socioeconomic impacts on the region.

4.13.2 Alternative 1 - SLCs 36 A and 36 B

Socioeconomic impacts generated by operation of Alternative 1 would be identical to those of the Proposed Action, and would therefore not be considered significant. Socioeconomic impacts generated by refurbishment activities for Alternative 1 would be identical to those of the Proposed Action. Therefore, Alternative 1 would not generate any significant adverse impacts on the socioeconomics of the region, and minor positive impacts may actually be generated.

4.13.3 Alternative 2 – SLC 47

Socioeconomic impacts generated by operation of Alternative 2 would be identical to those of the Proposed Action, and would therefore not be considered significant. Socioeconomic impacts generated by refurbishment activities for Alternative 2 would be identical to those of the Proposed Action. Therefore, Alternative 2 would not generate any significant adverse impacts on the socioeconomics of the region, and minor positive impacts may actually be generated.

4.13.4 No-Action Alternative

Under the No-Action Alternative, the Falcon Launch Vehicle Program would not be implemented; therefore, no operational or refurbishment impacts on socioeconomics would occur.

4.14 ENVIRONMENTAL JUSTICE

This section discusses the affect of implementation of either the proposed action, or the two alternatives on risk or rate of environmental hazard exposure by a minority or low-income population or affects on the health of a minority or low-income population affected by cumulative or multiple adverse exposures from environmental hazards.

4.14.1 Proposed Action – SLC 40

The Proposed Action would occur within the boundaries of CCAFS and over the Atlantic Ocean. Existing impoverished and minority populations are spread fairly evenly within Brevard County. The closest such group of people reside approximately 8 miles south of the planned launch sites in the City of Coaco Beach. Based on 2006 Bureau of Economic Analysis and the Census Bureau data, Brevard County's minority population (Black, Indian, Asian and Hispanic/Latino) is approximately 21.3% of the Counties 535,000 people. The percentage of minorities in neighboring Seminole County is 8 % higher; the percentage of minority in Orange County to the west is almost 30% higher and Florida's minority population is 16% higher than Brevard County. The conclusion is that CCAFS and the launch facilities are located in an area that supports Environmental Justice goals.

Launch anomalies which although at a very low probability may occur, would happen either seven miles away from the nearest residence, or out over the Atlantic. Therefore environmental impacts generated by operation, construction and refurbishment activities for the Proposed Action would be less than significant and would not affect minority or low-income populations or children listed in Section 3.14. Therefore, operation and refurbishment of the Proposed Action would not cause any environmental justice impacts.

The reuse and positioning of the SLC 40 site, or any of the other alternative options at CCAFS, would also not have a discernable impact on any Environmental Justice subject groups.

4.14.2 Alternative 1 - SLCs 36 A and 36 B

Environmental justice impacts generated by Alternative 1 would be identical to those generated by the Proposed Action. Therefore, no impacts would be generated.

4.14.3 Alternative 2 – SLC 47

Environmental justice impacts generated by Alternative 2 would be identical to those generated by the Proposed Action. Therefore, no impacts would be generated.

4.14.4 No-Action Alternative

Under the No-Action Alternative, the Falcon Launch Vehicle Program would not be implemented. Therefore, no environmental justice impacts would be generated.

5.0 APPLICABLE ENVIRONMENTAL REQUIREMENTS

This section provides a description of some, but not all federal, state, and Air Force regulations with which SpaceX must comply prior to and during construction and operation of the proposed project.

5.1 FEDERAL REGULATIONS

Federal Regulations Regarding Environmental Quality

The National Environmental Policy Act (42 U.S.C. 4321-4347 as amended) requires federal agencies to analyze the potential environmental impacts of major federal actions and alternatives and to use these analyses as a decision making tool on whether and how to proceed with the Proposed Action or Alternatives.

Federal Regulations Regarding Biological Resources

Public Law 93-205 requires military installations to protect and conserve federally listed, endangered, and threatened plants and wildlife.

The Endangered Species Act of 1973 declares the intention of the Congress to conserve threatened and endangered species and the ecosystems on which those species depend. The Act requires that federal agencies, in consultation with the U.S. Fish and Wildlife Service and NOAA Fisheries, use their authorities in furtherance of its purposes by carrying out programs for the conservation of endangered or threatened species.

Section 7 of the Endangered Species Act (16 U.S.C. 1536) contains provisions that require federal agencies to consult with the Secretary of Interior and to take necessary actions to ensure that actions authorized, funded, or carried out by them do not jeopardize the continued existence of endangered species and threatened species. Federal agencies must ensure that actions taken will not result in the destruction or modification of the habitat of endangered species.

Marine Mammal Protection Act (16 U.S.C. 1361 et seq.), Section 101(a)(5)(A) directs the Secretary of Commerce to allow, upon request, the incidental, but not intentional, taking of marine mammals by United States citizens who engage in a specified activity (other than commercial fishing) within a specified geographical region if certain findings are made and regulations are issued. Permission may be granted for periods of 5 years or less if the NMFS finds that the taking will have a negligible impact on the species or stock(s); will not have an unmitigatable adverse impact on the availability of the species or stock(s) for subsistence uses; and the permissible methods of taking and requirements pertaining to the monitoring and reporting of such taking are set forth.

The Florida Endangered and Threatened Species Act (FETSA) establishes the conservation and wise management of T&E species as State policy. Agencies are required to consider impacts to T&E species when planning and implementing projects, as mandated by the Florida Fish and Wildlife Conservation Commission (FFWCC).

The Magnuson-Stevens Fishery Conservation and Management Act (Sustainable Fisheries Act) identifies EFH and threats to EFH. This Act requires consultation with NMFS to ameliorate any threats to EFH from non-fishing activities.

The Marine Mammal Protection Act prohibits the harassing or killing of any marine mammal. Harassment is any act of pursuit, torment, or annoyance which has the potential to injure a marine mammal or marine mammal stock in the wild by causing disruption of behavioral patterns, including, but

not limited to, migration, breathing, nursing, breeding, feeding, or sheltering. The Act requires the observation of distance requirements from marine mammals as imposed by the NFMS.

Federal Regulations Regarding Cultural Resources

The National Historic Preservation Act of 1966 (Public Law 89-665), as amended; Executive Order 11593 of 1971 (36 CFR 154); the American Indian Religious Freedom Act of 1978 (Public Law 95-341); the Archaeological Resource Protection Act of 1979 (Public Law 96-95); the Native American Graves Protection and Repatriation Act of 1990 (Public Law 101-601); and the Air Force Instruction for cultural resource management of 1994 (AFI 32-7065).

On a day-to-day basis, cultural resource management CCAFS is guided primarily by the National Historic Preservation Act and its implementing regulations, 36 CFR 800. Briefly, Section 106 requires federal agencies to take into account the effect of any undertaking on any district, site, building, structure, or object that is on or eligible for the National Register. An undertaking is defined as "a project, activity, or program funded in whole or part under the direct or indirect jurisdiction of a Federal Agency, including those carried out by or on behalf of a Federal Agency; those carried out with Federal financial assistance; those requiring a Federal permit, license, or approval; and those subject to state or local regulation administered pursuant to a delegation or approval by a Federal agency" (36 CFR 800.16[y]). For any undertaking, the Section 106 process requires identification of historic properties (i.e., those on or eligible for the National Register), assessment of potential adverse project effects on any historic properties, and resolution of adverse effects in consultation with the State Historic Preservation Officer and/or, if necessary, the Advisory Council on Historic Preservation.

The Archaeological Resource Protection Act was passed in 1979 to protect archaeological resources and sites on public lands, and requires a permit for any excavation or removal of archaeological resources from public lands. The Native American Graves Protection and Repatriation Act and its implementing regulations, 43 CFR 10, provides ownership or control of Native American human remains and selected cultural items excavated or discovered on federal lands with designated Native American tribes, organizations, or groups. If human remains or selected cultural items are discovered on federal lands, the appropriate Native American group must be notified. AFI 32-7065 provides detailed guidance for compliance with relevant extant authorities.

Federal Regulations Regarding Air Quality

The proposed project is federally regulated by the following Titles (listed and discussed below):

Title 40 CFR 50: NAAQS;

Title 40 CFR 51: Requirements for Preparation, Adoption, and Submittal of Implementation Plans;

Title 40 CFR 61: NESHAP;

Title 50 CFR 63: NESHAP for Source Categories;

Title 40 CFR 70: State Operating Permit Program; and

Title 49 CFR Parts 100-199: Hazardous Materials Regulation.

Title 40 CFR 50 (NAAQS): The Clean Air Act required the U.S. EPA to establish ambient ceilings for certain criteria pollutants. Subsequently, the U.S. EPA promulgated regulations that set NAAQS. Two classes of standards were established: primary and secondary. Primary standards prescribe the maximum permissible concentration in the ambient air required to protect public health. Secondary standards specify levels of air quality required to protect public welfare, including materials, soils, vegetation, and wildlife, from any known or anticipated adverse effects. The criteria pollutants for which the NAAQS have been established include carbon monoxide, nitrogen dioxide, ozone, PM₁₀, PM_{2.5}, and sulfur dioxide.

The U.S. EPA classifies air quality within each Air Quality Control Region with regard to its attainment of federal primary and secondary NAAQS. According to U.S. EPA guidelines, an area with air quality better than the NAAQS for a specific pollutant is designated as in attainment for that pollutant. Any area not meeting ambient air quality standards is classified as nonattainment. When there is a lack of data for the U.S. EPA to define an area, the area is designated as unclassified and treated as an attainment area until proven otherwise.

Title 40 CFR 51 Subpart W (General Conformity): General conformity rule applies to federal actions that are not covered by transportation conformity rule, with several listed exceptions. Other than the listed exemptions and presumptions of conformity, general conformity applies to actions in which projected emissions exceed applicable conformity de minimis thresholds. However, if the emissions from a federal action do not equal or exceed de minimis thresholds but do represent 10 percent or more of a nonattainment or maintenance area's total emissions of any criteria pollutant, the action is considered "regionally significant" and the requirements of conformity determination apply.

Title 40 CFR 61(NESHAP): The NESHAP regulates stationary sources with a prescribed standard under Title 40 CFR 61. Such stationary sources may be required to obtain an operating permit issued by an authorized Air Pollution Control agency or by U.S. EPA in accordance with Title V of the Clean Air Act. The NESHAP identifies and list a variety of hazardous air pollutants that are regulated.

The only sections of NESHAP standards that may apply to the proposed project is Title 50 CFR 63 Subpart GG for manufacturers of commercial, civil, or military aerospace vehicles or components and that are major sources of hazardous air emissions. Such emissions would result from cleaning operations, surface coating with primers and topcoats, paint removal, and waste storage.

Hazardous wastes that are subject to RCRA requirements would be exempt from the subpart. Those wastes would include specialty coatings, adhesives, primers, and sealant materials at aerospace facilities. Other exemptions would include hazardous air pollutants or VOC contents less than 0.1 percent for carcinogens or 1.0 percent for non-carcinogens and low volume coatings.

Title 40 CFR 70 (State Operating Permit Programs): In accordance with Title V of the Clean Air Act large facilities that are capable of producing large amounts of air pollution are required to obtain an operating permit. Permits are issued by the District. Typical activities that require the Clean Air Act Title V permit include any major source (source that emits more than 100 tons per year of criteria pollutant in a nonattainment area for that pollutant or is otherwise defined in Title I as a major source); affected sources as defined in Title IV; sources subject to Section 111 regarding New Source Performance Standards; sources of air toxics regulated under Section 112 of the Clean Air Act; sources required to have new source or modification permits under Parts C or D of Title I of the Clean Air Act; and any other source such as Hazardous Waste pollutants designated by U.S. EPA regulations.

Part 70 Federal Operating Permits are issued to specific emission sources. Sources requiring permits are determined based on the source's potential to emit certain threshold levels of pollution given their equipment and processes.

Facilities requiring Part 70 Federal Operating Permits include sources with the potential to emit the following:

- Regulated air pollutant or HAP amounts equal to or greater than:
 - 100 tons/year of any regulated air pollutant;
 - 10 tons/year of any individual HAP or 25 tons/year of a combination of HAPs; or
 - Lesser quantity thresholds for any HAP established by the U.S. EPA rulemaking.
- Any stationary source defined by the U.S. EPA as major for the District under Title I, Part D (Plans for Nonattainment Areas) of the Clean Air Act and its implementing regulations including:
 - For ozone nonattainment areas, sources with the potential to emit 100 tons per year or more of volatile organic compounds or oxides of nitrogen in areas classified as "marginal" or "moderate," 50 tons per year or more in areas classified as "serious," 25 tons per year or more in areas classified as "severe," and 10 tons per year or more in areas classified as "extreme";
- Acid rain sources included under the provisions of Title IV of the Clean Air Act and its implementing regulations.
- Any source required to have a pre-construction review permit pursuant to the requirements of the New Source Review/Prevention of Significant Deterioration program under Title I, Parts C and D of the Clean Air Act and its implementing regulations;
- Any solid waste incineration unit required to obtain a Part 70 permit pursuant to Section 129(e) of the Clean Air Act and its implementing regulations; and
- Any stationary source in a source category required to obtain a Part 70 permit pursuant to regulations promulgated by the U.S. EPA Administrator.

Title 49 CFR Parts 100-199: Liquid propellant for the Falcon launch vehicle must be shipped and handled in accordance with Title 49 CFR Parts 100-199. The liquid propellants would be shipped directly from the manufacturing location to the launch site.

Federal Regulations Regarding Hazardous Waste/Hazardous Materials

The CERCLA of 1980 responds to the immediate cleanup of hazardous waste contamination from accidental spills or from waste disposal sites that may result in long-term environmental damage.

The RCRA of 1974 (42 U.S.C. 6901 et seq.) was designed to control the handling and disposal of hazardous substances by responsible parties. Hazardous waste, as defined by RCRA, is a "waste that may cause or significantly contribute to serious illness or death, or that poses a substantial threat to human health or the environment when improperly disposed." The treatment, storage, and disposal of solid waste (both hazardous and nonhazardous) is regulated under the Solid Waste Disposal Act as amended by RCRA and the Hazardous and Solid Waste Amendments of 1984.

The SARA of 1986, Title III: Emergency Planning and Community Right-to-Know Act establishes standards for community right-to-know programs, and requires the reporting of releases of certain toxic chemicals. Local planning committees, comprising government, news media, industry, environmental, organizations, and medical representatives, receive right-to-know information from facilities. Facilities with Standard Industrial Classification codes between 20 and 39 that manufacture, process, or otherwise use listed toxic chemicals, must report a release of these toxic chemicals to the environment, in greater than reportable quantities, on a Form R.

Under 49 CFR Section 170 are Department of Transportation requirements for the shipment of hazardous materials. This section specifies the proper container type, shipping name, and labeling requirements for the transportation of hazardous materials.

The Toxic Substances Control Act of 1976 regulates chemical substances and mixtures that present an unreasonable risk of injury to health, or the environment, and acts with respect to chemical substances and mixtures which are imminent hazards.

Federal Regulations Regarding Water Resources

The Clean Water Act (33 U.S.C. 1251 et seq.) prohibits the discharge of pollutants from a point source into navigable waters of the United States, except in compliance with a NPDES (40 CFR Part 122) permit. The navigable waters of the United States are considered to encompass any body of water whose use, degradation, or destruction will affect interstate or foreign commerce.

Section 402 of the Clean Water Act requires that the U.S. EPA establish regulations for issuing permits for storm water discharges associated with industrial activity. A NPDES permit is required if activities involve the disturbance of 1 to 5 acres of land. A Notice of Intent must be submitted to the SJRWMD by SpaceX and a storm water pollution prevention plan must be developed.

Section 404 establishes a program to regulate the discharge of dredged and fill materials into waters of the United States, including wetlands. Activities in waters of the United States that are regulated under this program include fills for development, water resource projects (such as dams and levees), infrastructure development (such as highways and airports), and conversion of wetlands to uplands for farming and forestry. U.S. EPA and the Corps of Engineers jointly administer the program. In addition, the U.S. Fish and Wildlife Service, NOAA Fisheries, and state resource agencies have important advisory roles.

Federal Regulations Regarding Environmental Justice

Executive Order 12898 (Federal Actions to Address Environmental Justice in Minority Populations and Low Income Populations) requires that all federal agencies develop environmental justice strategies and make environmental justice a part of their mission by identifying and addressing, as appropriate, any disproportionate and adverse human health or environmental effects of their activities on minority or low income populations.

State of Florida Regulations

The Coastal Zone Management Act (CZMA) of 1972 (16 USC 2452-24645) (Florida Department of Community Affairs (FDCA)) plays a significant role in water quality management. Under the CZMA, a Federal action that may affect the coastal zone must be carried out in a manner that is consistent with state coastal zone management programs.

6.0 PERSONS AND AGENCIES CONTACTED

Camardese, Michael B.
Cultural and Natural Resources Program Manager
45 CES/CEVR
185 West Skid Strip Road, MS #2006
Patrick AFB, FL 32925-2231

Chambers, Angy
45 CES/CEVR
185 West Skid Strip Road
Patrick AFB, FL 32925-2231

Hillyer, Rich
45th Space Wing
Program Requirements Office
16460 Hanger Road (CCAFS)
Patrick AFB, FL 32925

Hooper, Kevin
45 CES/CEVR
185 West Skid Strip Road, MS #2006
Patrick AFB, FL 32925-2231

Kershner, Mark A.
45 CES/CEVR
185 West Skid Strip Road, MS #2006
Patrick AFB, FL 32925-2231

Pastucha, Richard E.
St. Johns River Water Management District
19561-B SE Highway 42
Umatilla, FL 32784

Phillips, Daniel
Spec Pro
Mail Unit ESC
Patrick AFB, FL 32925

Sanibani, Pius
Spec Pro
Air Pollution Program Engineer
16460 Hanger Road (CCAFS)
CCAFS

Sutherland, Robin
45 CES/CEVR
185 West Skid Strip Road, MS #2006
Patrick AFB, FL 32925-2231

Thoben, Thomas, CHMM,REM
Hazardous Waste Program Manager
45th Space Wing 45CES/CEVC
1224 Jupiter Street
Patrick AFB, FL 32925

Zee, Stacy
Environmental Specialist
Commercial Space Transportation
Federal Aviation Authority
800 Independence Ave, SW, St 331
Washington DC 20591

Kumor, Kenneth
NEPA Coordinator and Cultural Resource
Compliance
NASA Headquarters I&A/Env. Mgmt
Div. Mail Suite 5B42
300 E Street, SW Washington, DC
20546

Sally B. Mann, Director
Lauren P. Milligan
Office of Intergovernmental Programs
Florida Dept. of Environmental Protection
3900 Commonwealth Boulevard
Tallahassee, Florida 32399-3000

Public Relations Office
45SW/PA
1201 Edward H. White II MS 7105
Patrick Air Force Base, Florida, 32925

7.0 LIST OF PREPARERS

Albright, Melissa
Project Geologist
B.S., Geology, University of Southwestern Louisiana, 1986

Cornaby, Barney Ph.D.
Technical Reviewer
Environmental Sciences, SAIC
Ph.D. Ecology, University of Georgia, 1973

Elson, Philip
Vice President/Program Manager
B.S., Biology, Illinois State University, 1982

Exner, Gary
Principal Consultant; Advantage Consulting, LLC
B.S. University of South Florida, 1973
M.A. University of Phoenix, 2000

Garza, Tracy
Staff Geologist
B.S., Geology, Florida State University, 1997

Kaiser, John
Program Manager
B.S., Physical Science/General Engineering, United States Naval Academy, 1979

Potter, Donna
Senior Scientist
B.A., Environmental Studies/ Social Sciences, University of North Carolina, 1976

Rangel, Angela
Biologist
B.S., Marine Biology, Texas A&M University, 1989
M.S., Biology, University of South Alabama, 2000

8.0 REFERENCES AND DOCUMENTS CITED

AEROSPACE, 1994. Zittel, P. F., *Computer Model Predictions of the Local Effects of Large Solid Fuel Rocket Motors on Stratospheric Ozone*, Technical Report TR-94(4231)-9, The Aerospace Corporation, El Segundo, CA, 1994.

AEROSTAR, 2006. Record of personal communication between John Kaiser and Philip Elson of Aerostar Environmental Services, Inc and Anne Chinnery of SpaceX, October 2006.

AEROSTAR, 2007. Record of personal communication between John Kaiser of Aerostar Environmental Services, Inc. and Norm Bobczynski of SpaceX, May 2007.

AEROSTAR, 2007. Record of personal communication between Anna Dziadon of Aerostar Environmental Services, Inc. and Thomas E. Penders, RPA of 45 SW, July 2007.

AFI 32-7042, 1994. U. S. Air Force, U. S. Air Force Instruction AFI 32-7042. Solid and Hazardous Waste Compliance, 12 May 1994.

AFI 32-7064, 1997. U. S. Air Force, U. S. Air Force Instruction AFI 32-7064. International Natural Resource Management, 01 August 1997.

AFI 32-7080, 1994. U. S. Air Force, U. S. Air Force Instruction AFI 32-7080. Pollution Prevention Program, 12 May 1994.

AFI 32-7086, 1997. U. S. Air Force, U. S. Air Force Instruction AFI 32-7086. HAZMAT Management, 01 August 1997.

AFPD 32-70, 1994. U. S. Air Force, U. S. Air Force Policy Directive 32-70, Environmental Quality, 20 July 1994.

ANSI Z136.1, 2000. American National Standard for Safe Use of Lasers ANSI Z136.1-2000 Revision of ANSI Z136.1-1993, Approved by American National Standards Institute, Inc. Published by Laser Institute of America, 28 June 2000.

ANSI Z136.6, 2000. American National Standard for Safe Use of Lasers Outdoors ANSI Z136.6-2000, Approved by American National Standards Institute, Inc. Published by Laser Institute of America, 9 August 2000.

DO, 1994. Do, T.T., *Titan IV Launch Sound Levels at 2,700, 6,680, 11,200, 16,800, 19,000, and 43,129 Feet From the Pad*, January 1994.

REFERENCES Cont.

- EWR 127-1, 1997. U. S. Air Force, Eastern and Western Range 127-1, 31 October 1997 (in revision 2001).
- ILS, 1999. International Launch Services, Atlas Launch System Mission Planner's Guide Atlas V Addendum (AVMPG), December 1999.
- JACKMAN, 1998. Jackman, C. H., et al., *A global modeling study of solid rocket aluminum oxide emission effects on stratospheric ozone*, Geophys. Res. Letts., 25, 907-910, 1998.
- KUNKEL, 1991. Kunkel, Bruce A., *AFTOX 4.0 - The Air Force Toxic Chemical Dispersion Model - A User's Guide*, 8 May 1991.
- MCINERNY, 1993. McInerny, S. A., *Delta Launch Sound Levels at 1500, 2000, 3000, and 4000 Feet From the Pad*, January 1993.
- NASA, 1995a. National Aeronautics and Space Administration, Final Environmental Impact Statement for the Cassini Mission, June 1995.
- NASA, 1995b. National Aeronautics and Space Administration, Mars Global Surveyor Mission Environmental Assessment, September 1995.
- NASA, 1997. National Aeronautics and Space Administration, Environmental Resources Document, John F. Kennedy Space Center, NASA, 1997.
- NASA, 1998. National Aeronautics and Space Administration, New Millennium Program Environmental Assessment, June 1998.
- NASA, 2001. National Aeronautics and Space Administration, Acquisition Pollution Prevention Program's Extracted Information from "KSC Hazardous Waste Report", John Fusco, 04 September 2001.
- NASA, 2002. National Aeronautics and Space Administration, NASA Routine Payload Final Environmental Assessment, June 2002.
- NPD 8610.7, 1999. National Aeronautics and Space Administration, NASA Policy Directive (NPD): 8610.7. Launch Services Risk Mitigation Policy for NASA-Owned or NASA-Sponsored Payloads, 04 February 1999.
- NPD 8710.1, 1997. National Aeronautics and Space Administration, NASA Policy Directive (NPD): 8710.1. Emergency Preparedness Program, 24 February 1997.

REFERENCES Cont.

NPD 8710.2B, 1997. National Aeronautics and Space Administration, NASA Policy Directive (NPD): 8710.1. NASA Safety and Health Program Policy, 10 June 1997.

NPG 8710.3, 1997. National Aeronautics and Space Administration, NASA Procedures and Guidelines (NPG): 8710.3. NASA Policy for Limiting Orbital Debris Generation, 29 May 1997.

NPG 8715.1, 1999. National Aeronautics and Space Administration, NASA Procedures and Guidelines (NPG): 8715.1. NASA Safety and Health Handbook Occupational Safety and Health Programs, 09 August 1999.

NPG 8715.3, 2000. National Aeronautics and Space Administration, NASA Procedures and Guidelines (NPG): 8715.3. NASA Safety Manual, 24 January 2000.

NPG 8820.3, 1999. National Aeronautics and Space Administration, NASA Procedures and Guidelines (NPG): 8820.3. Pollution Prevention, 1 March 1999.

NRC, 1995. National Research Council (U. S.) Committee on Space Debris. *Orbital Debris: A Technical Assessment*, National Academy Press, Library of Congress Catalog Number: 95-18686, ISBN 0-309-05125-8, 1995.

ORBITAL, 1992. Orbital Sciences Corporation, Commercial Taurus Launch System Payload User's Guide (TD-2493), August 1992.

ORBITAL, 2000. Orbital Sciences Corporation, Pegasus User's Guide, August 2000.
OSTP, 1995. Office of Science and Technology Policy Interagency Report on Orbital Debris, National Science and Technology Council, Library of Congress Catalog Card Number: 95-72164. November 1995.

ROSS, 2000. M. N. Ross et al., *Observation of Stratospheric Ozone Depletion Associated with Delta II Rocket Emission*, Geophys. Res. Letts., 27, 2209-2212, 2000.

SCHMALZER, 1998b. Schmalzer, Paul A., et al., *Monitoring Direct Effects of Delta, Atlas, and Titan Launches from Cape Canaveral Air Station*, NASA/TM 1998-207912, June 1998.

SPACE X, 2007a. Jessica Jensen of SpaceX Email June 1, 2007.

SPACE X, 2007b. Anne Chinnery of SpaceX Email June 8, 2007.

SPECPRO, 2006. Conference Call between Pius Sanibani, Air Pollution Program Engineer, CCAFS of SPECPRO and Donna Potter of AEROSTAR, 06 Dec. 2006.

REFERENCES Cont.

UN, 1999. United Nations, Technical Report on Space Debris. United Nations Publication Sales No.: E.99.I.17, ISBN 92-1-100813-1, 1999.

USAF, 1988. U. S. Air Force, Environmental Assessment (for the) U. S. Air Force, Space Division Medium Launch Vehicle Program Cape Canaveral Air Force Station Florida, May 1988.

USAF, 1995c. U. S. Air Force, Environmental Assessment for Defense Satellite Communications System III with Integrated Apogee Boost System, Cape Canaveral Air Station, Florida, July 1995.

USAF, 1996a. U. S. Air Force, 45th Space Wing OPlan 32-3, Volume I, Hazardous Materials (HAZMAT) Emergency Response And Training, March 1996 (revision in progress with planned release in spring 2002).

USAF, 1996b. U. S. Air Force, Final Environmental Assessment for the Delta III Launch Vehicle Program Cape Canaveral Air Station Florida, April 1996.

USAF, 1998. U. S. Air Force, Final Environmental Impact Statement Evolved Expendable Launch Vehicle, April 1998.

USAF, 2000a. U.S. Air Force, Final Supplemental Environmental Impact Statement Evolved Expendable Launch Vehicle, March 2000.

USAF, 2000b. U. S. Air Force, Record of Decision - Final Supplemental Environmental Impact Statement (FSEIS) for the Evolved Expendable Launch Vehicle (EELV), May 2000.

Environmental Impact Statement (FSEIS) for the Evolved Expendable Launch Vehicle (EELV), May 2000.

USAF, 2001. U. S. Air Force, SMC Orbital Hazards and Debris Mitigation User's Handbook, January 2001.

USAF, 2003. U. S. Air Force, Environmental Assessment (for the) Falcon Launch Program, Vandenberg Air Force Station, July 2003.

USAF, 2005a. U. S. Air Force, Programmatic Final Environmental Assessment for Reactivation/Reuse of 12 Space Launch Complexes, Cape Canaveral Air Force Station, March 2005.

USAF, 2005b. U. S. Air Force, Environmental Assessment for the Deactivation and Turnover of Titan Space Launch Vehicle Capability, May 2005.

REFERENCES Cont.

USAF, 2005c. U. S. Air Force, Environmental Assessment for the New NRO Eastern Processing Facility, Cape Canaveral Air Force Station, August 2005.

USAF, 2006. U. S. Air Force, Environmental Assessment (for the) Proposed Bulk Fuel Storage Facility, Cape Canaveral Air Force Station, June 2006.

USAF, 2006a. U.S. Air Force, Environmental Assessment for the Demolition, Construction, Operation, and Maintenance of new Boat Docks, Boat Ramp, and Support Facility at Cape Canaveral Air Force Station, FL, August 2006.

USAF, 2007. U.S. Air Force, Contaminated Soil Removal Action at SLC 40, April, 2007.

U.S. Bureau of the Census 2005 General Population Characteristics. U.S. Census Bureau Home Page. <http://www.census.gov>.

U.S. Department of Agriculture, 1972 Soil Survey, Soil Conservation Service Brevard County.

WMO, 1991. World Meteorological Organization, Global Ozone Research and Monitoring Project - Report No. 25: *Scientific Assessment of Ozone Depletion: 1991*, 1991.

WMO, 1999. World Meteorological Organization, Global Ozone Research and Monitoring Project - Report No. 44: *Scientific Assessment of Ozone Depletion: 1998*, February 1999.

ZOLENSKY, 1989. Zolensky et. al., *Tenfold Increase in the Number of Large Particles in the Stratosphere as Measured over the Period 1976-1984*, J. Geophys. Res., 94, 1047-1056, 1989.

45 SW, 1995. 45 Space Wing General Plan, Cape Canaveral Air Force Station, Florida, 1995.

45 SW, 2007. Thomas E. Penders, RPA of 45 CES/CEVP Email July 26, 2007.

APPENDIX A

John Kaiser

From: Stacey.Zee@faa.gov [Stacey.Zee@faa.gov]
To: John Kaiser
Cc:
Subject: Fw: Space X EA for launch of Falcon 1 and 9 at SLC 40
Attachments:

Sent: Fri 11/17/2006 1:00 PM

Stacey M. Zee
 Environmental Specialist
 Commercial Space Transportation
 Federal Aviation Administration
 800 Independence Ave SW, Suite 331
 Washington, DC 20591
 (202)267-9305 voice (202)267-5463 fax

----- Forwarded by Stacey Zee/AWA/FAA on 11/17/2006 01:00 PM -----

"Chambers, Angy L Civ 45 CES/CEVP"
 <Angy.Chambers@patrick.af.mil>

To Stacey Zee/AWA/FAA@FAA, "Sutherland, Robin L Civ 45 CES/CEVP"
 <Robin.Sutherland@patrick.af.mil>
 cc "Wassel, Alfred E Civ FAA/AST-20" <Alfred.Wassel@patrick.af.mil>,
 "Underwood, Pamela J Civ FAA/AST-20"
 <Pamela.Underwood@patrick.af.mil>, Ken Gidlow/AWA/FAA@FAA
 Subject RE: Space X EA for launch of Falcon 1 and 9 at SLC 40

11/01/2006 10:14 AM

Stacey - I'm fairly certain we don't need an official letter, but I'm checking with our MAJCOM to confirm that. I'll let you know what they say. I'm looking forward to working with you. Thanks.

From: Stacey.Zee@faa.gov [mailto:Stacey.Zee@faa.gov]
Sent: Wednesday, November 01, 2006 9:32 AM
To: Chambers, Angy L Civ 45 CES/CEVP; Sutherland, Robin L Civ 45 CES/CEVP
Cc: Wassel, Alfred E Civ FAA/AST-20; Underwood, Pamela J Civ FAA/AST-20; Ken.Gidlow@faa.gov
Subject: Re: Space X EA for launch of Falcon 1 and 9 at SLC 40

Angy -

John Kaiser contacted me last week about the EA that AeroStar is putting together for proposed SpaceX operations from SLC 40. Our understanding is that the Air Force is the lead agency on this EA.

If SpaceX pursues a commercial launch license for any of their operations from the Cape, the FAA would use the analysis in the EA to support the licensing decision. Therefore, it would be helpful for FAA to participate as a cooperating agency on the development of this EA.

Please consider this a request for the FAA to participate as a cooperating agency on the SpaceX EA. Please let me know if you need a formal letter from our office.

Regards,
 Stacey Zee

Stacey M. Zee
 Environmental Specialist
 Commercial Space Transportation
 Federal Aviation Administration
 800 Independence Ave SW, Suite 331
 Washington, DC 20591
 (202)267-9305 voice (202)267-5463 fax

APPENDIX B

REQUEST FOR ENVIRONMENTAL IMPACT ANALYSIS

Report Control Symbol
RCS: 0609-1

INSTRUCTIONS: Section I to be completed by Proponent; Sections II and III to be completed by Environmental Planning Function. Continue on separate sheets as necessary. Reference appropriate item number(s).

SECTION I - PROPONENT INFORMATION

1. TO (Environmental Planning Function)	2. FROM (Proponent organization and functional address symbol)	2a. TELEPHONE NO.
45 CES/CEV	Space Exploration Technologies	310-607-3257

3. TITLE OF PROPOSED ACTION
Falcon Program Launch Operations

4. PURPOSE AND NEED FOR ACTION (Identify decisions to be made and need date)
See page 2.

5. DESCRIPTION OF PROPOSED ACTION AND ALTERNATIVES (DOPAA) (Provide sufficient details for evaluation of the total action.)
See page 2.

6. PROPONENT APPROVAL (Name and Grade)	6a. SIGNATURE	6b. DATE
Timothy G. Buzza	//SIGNED//	25 Sep 06

SECTION II - PRELIMINARY ENVIRONMENTAL SURVEY. (Check appropriate box and describe potential environmental effects including cumulative effects.) (+ = positive effect; 0 = no effective; - = adverse effect; U = unknown effect)

	+	0	-	U
7. AIR INSTALLATION COMPATIBLE USE ZONE/LAND USE (Noise, accident potential, encroachment, etc.)	<input type="checkbox"/>	<input type="checkbox"/>	<input type="checkbox"/>	<input checked="" type="checkbox"/>
8. AIR QUALITY (Emissions, attainment status, state implementation plan, etc.)	<input type="checkbox"/>	<input type="checkbox"/>	<input type="checkbox"/>	<input checked="" type="checkbox"/>
9. WATER RESOURCES (Quality, quantity, source, etc.)	<input type="checkbox"/>	<input type="checkbox"/>	<input type="checkbox"/>	<input checked="" type="checkbox"/>
10. SAFETY AND OCCUPATIONAL HEALTH (Asbestos/radiation/chemical exposure, explosives safety quantity-distance, etc.)	<input type="checkbox"/>	<input type="checkbox"/>	<input type="checkbox"/>	<input checked="" type="checkbox"/>
11. HAZARDOUS MATERIALS/WASTE (Use/storage/generation, solid waste, etc.)	<input type="checkbox"/>	<input type="checkbox"/>	<input type="checkbox"/>	<input checked="" type="checkbox"/>
12. BIOLOGICAL RESOURCES (Wetlands/floodplains, flora, fauna, etc.)	<input type="checkbox"/>	<input type="checkbox"/>	<input type="checkbox"/>	<input checked="" type="checkbox"/>
13. CULTURAL RESOURCES (Native American burial sites, archaeological, historical, etc.)	<input type="checkbox"/>	<input checked="" type="checkbox"/>	<input type="checkbox"/>	<input type="checkbox"/>
14. GEOLOGY AND SOILS (Topography, minerals, geothermal, Installation Restoration Program, seismicity, etc.)	<input type="checkbox"/>	<input type="checkbox"/>	<input type="checkbox"/>	<input checked="" type="checkbox"/>
15. SOCIOECONOMIC (Employment/population projections, school and local fiscal impacts, etc.)	<input type="checkbox"/>	<input type="checkbox"/>	<input type="checkbox"/>	<input checked="" type="checkbox"/>
16. OTHER (Potential impacts not addressed above.)	<input type="checkbox"/>	<input checked="" type="checkbox"/>	<input type="checkbox"/>	<input type="checkbox"/>

SECTION III - ENVIRONMENTAL ANALYSIS DETERMINATION

17. PROPOSED ACTION QUALIFIES FOR CATAGORICAL EXCLUSION (CATEX) ; OR
 PROPOSED ACTION DOES NOT QUALIFY FOR A CATEX; FURTHER ENVIRONMENTAL ANAYLYSIS IS REQUIRED.

18. REMARKS
OK 12 Oct 06 AS 1300
 See page 3.

19. ENVIRONMENTAL PLANNING FUNCTION CERTIFICATION (Name and Grade)	19a. SIGNATURE	19b. DATE
E. ALEXANDER STOKES III, GS-14 Chief, Environmental Flight	<i>E. A. Stokes III</i>	13 Oct 2006

AF Form 813
Page 2
0609-1

4. Purpose and Need for Action

Space Exploration Technologies (SpaceX) requires a launch site at the Eastern Range for the Falcon 1 and 9 launch vehicle programs to support commercial, DoD, and NASA customers desiring launch to easterly and ISS inclinations. Based on initial conversations with the Eastern Range, SLC-40 has tentatively been selected, and environmental approval is needed for program operations and use of SLC-40.

5. Description of Proposed Action and Alternatives

The Proposed Action is to conduct regular launch operations placing small, medium, and heavy class payloads into orbit from (tentatively) SLC-40 at CCAS with the Falcon 1 and Falcon 9 launch vehicles. The Falcon 1 and 9 system launches will begin in 2008 after site preparation activities. An average of 6 Falcon 1 launches per year is predicted and up to 6 Falcon 9 launches per year starting after 2008. All flights are expected to have satellite payloads or other experimental payloads.

The Falcon 1 is a light-lift, two stage launch vehicle, designed to put small spacecraft into orbit with high reliability and low cost. The first stage is recoverable. The Falcon 1 uses the liquid propellants liquid oxygen (LOX) and RP-1, a type of kerosene commonly used as a rocket propellant. Some payloads are expected to be loaded with liquid or solid propellants for use in orbit after the flight. The Falcon 9 is a two stage, liquid launch vehicle in the medium to heavy launch class that will also be used to launch space systems and satellites into orbit. The propellants for the vehicle itself (both stages) are liquid oxygen (LOX) and RP-1 kerosene. The payloads may carry quantities of these or other propellants including NTO, MMH, other hydrazine propellants, and solid propellants. The first stage of the Falcon 9 will be recovered and is reusable, and the second stage will also be recovered and reused under some circumstances.

The Falcon 1 and 9 launch vehicles are designed for minimal vehicle assembly or processing at the launch site, with most of the vehicle assembly taking place at the SpaceX facilities in El Segundo, California. Both vehicles will arrive at CCAFS in two stages, each fully assembled. The stages will be checked out, assembled, and tested, and then moved to the launch pad. The Falcon 1 and Falcon 9 vehicles will both launch from the same pad at SLC-40. Both vehicles will be erected on the pad by hydraulic erector systems. Payloads will be processed in locally available commercial facilities. Both vehicles will be fueled on the pad and kerosene and LOX will be loaded the day of the launch. The goal is to launch within two weeks of vehicle arrival at the launch site.

To support the launch activities proposed, several improvements will be required at SLC-40, including some modifications to the launch stand itself, potential demolition of the SLC-40 pad tower, and the addition of a launch vehicle processing facility on the grounds of SLC-40. Also to be added are propellant storage tanks and plumbing associated with transfer of LOX, RP-1, and Helium to the launch vehicle. All site modifications will take place within the current fence line of SLC-40. Launch azimuths from this site will be primarily to 90 degrees for geo-transfer orbits and to 42.25 degrees for support of the International Space Station.

ALTERNATIVES

No Action – SpaceX would not meet its objective of providing low cost assured access to space in support of the national space policy; therefore, this alternative is not preferred.

Launch Vehicles at Alternate Location – Although the vehicles could be launched from other SLCs on CCAFS, other SLCs available have been inactive for several years and may require additional infrastructure and extended repairs, which could mean additional costs and impacts to the environment.

Construct New Complex – Development of a new complex would degrade the environment at undeveloped sites. SLC 40 has the infrastructure needed and was recently deactivated.

18. Remarks

Currently, proposed modifications to SLC 40 would include modifications to the launch stand itself, potential demolition of the SLC-40 pad tower, and the addition of a launch vehicle processing facility on the grounds of SLC-40. Also to be added are propellant storage tanks and plumbing associated with transfer of LOX, RP-1, and helium to the launch vehicle. All site modifications will take place within the current fence line of SLC-40. Vehicles were launched from the complex in the past, therefore impacts to the environment are not expected to be much different than what is presently occurring. The following remarks describe in general what resources could be impacted.

Projects creating 4,000 square feet or more of paved surface for vehicles will require an Environmental Resources Permit.

Projects creating 9,000 square feet or more of total impervious surface (the sum of building and parking area) will require an Environmental Resources Permit.

Coverage under an EPA Construction General Permit must be sought by the operator of a construction activity that:

- Will disturb one acre or greater, or
- Will disturb less than five acres but is part of a larger common plan of development or sale whose total land disturbing activities total five acres or greater (or is designated by the NPDES permitting authority);

AND

- Will discharge storm water runoff from the construction site into a municipal separate storm water sewer system (MS4) or waters of the United States.

If the above criteria apply, a Notice of Intent for Storm Water Discharges Associated with Construction Activity Under a NPDES General Permit must be submitted to EPA, through the 45 CES/CEV office. When all construction activities have been completed, a Notice of Termination must be submitted to EPA, through the CEV office. Contact the Environmental Support Contractor (ESC) at 853-6938 for information.

Provided that all modifications occur within the fence line, impacts to biological resources are expected to be negligible. Several years of post launch surveys conducted at several launch complexes on CCAFS has shown no adverse impacts to biological resources as the result of launches. Gopher tortoise burrows have been observed within the fence line of SLC 40. Any tortoises located in areas impacted by modifications to the facilities would require relocation.

To reduce adverse impacts to threatened and endangered sea turtles from artificial lighting operated on CCAFS, all exterior lighting proposed for this project must be designed and installed in accordance with the 45th Space Wing Instruction 32-7001, *Exterior Lighting Management*, dated 1 April 02. A Light Management Plan would be required for construction and operation of the facility. The Plan will require approval by the U. S. Fish and Wildlife Service.

Prior to 1983, PCBs were used in non-liquid applications such as caulk, sealants, paints, etc. If through documentation or prior knowledge, the planner has reason to believe that such materials are present, please contact the Environmental Support Contractor for sampling and disposal guidance. Liquid PCBs may be present in electrical equipment such as large high and low voltage switches, capacitors, hydraulic systems, or compressors. If equipment of this nature exists, it should be sampled for PCBs prior to disposal. Contact ESC for additional guidance.

Information on size and planned contents of aboveground and underground storage tanks must be submitted to the Environmental Support Contractor. Regulated fuel storage tanks must be constructed IAW FAC 62-761 and must be inspected and approved by FDEP before filling with fuel. Records on contents either loaded into each tank or dispensed from each tank must be kept by the Fuels Management and Bulk Storage Operations group in accordance with those specified in AFI 23-201 and AFI 23-110. This information is needed to calculate total air emissions from Air Force storage tanks and is called "through put" and "loading or unloading" emissions. This information is required for all tanks (including fuel tanks, chemical storage tanks, hazardous waste storage tanks, and pressurized tanks).

Secondary containment is required for fuel storage tanks and must be constructed IAW F.A.C. 62-761 and AFI 32-7044. Whenever possible, oil/water separators should be connected to sanitary sewer lines for discharge.

CCAFS is located in an area that is in attainment for all criteria air pollutants; therefore, a conformity determination is not required.

Projects involving installation of new air emission source (boilers, paint spray booths, etc.) must be coordinated through ESC for permit determination. FDEP requires air construction permit to be in place prior to initiation of construction of such projects.

Any asbestos abatement portion of this project and any other activities that may disturb ACM must be coordinated through the CCAFS ART and performed in-compliance with applicable State (FDEP) and Federal (EPA and OSHA) asbestos rules. The ART point of contact is Meredith Caukin at 867-3544.

- FDEP must be notified 10 days in advance of start of any project if the quantity of ACMs to be removed is determined to be equal to or greater than 160 sq. ft. or 260 linear ft.
- FDEP must also be notified 10 days in advance of the start of any project if it involves demolition (removal of load bearing member) regardless of whether facility contains ACM or not.
- Only those personnel trained and certified in handling ACMs can perform project work.
- Asbestos abatement requirements and procedures including but not limited to setting up containment, negative air, wet removal, air monitoring, etc. must be followed when necessary.
- Removed ACM must be properly disposed of at the CCAFS landfill (Asbestos Monofill). CCAFS landfill requires ACM to be double-bagged in 6-mil poly. You may contact CCAFS landfill at 853-4672 for specific requirements for ACM acceptance.

Any lead abatement and any other activities that may disturb lead-based paint must be performed in-compliance with applicable State (FDEP) and Federal (EPA and OSHA) lead-based paint and hazardous waste rules.

- Only those personnel trained in lead-based paint abatement (handling and disposal) must perform project.
- Project must be performed in manner that minimizes generation of airborne lead debris.
- Although water blasting of the paint is a wet method that minimizes generation of airborne lead paint debris, reasonable lead abatement requirements and procedures including but not limited to personal protection, cleaning any paint debris from the area at the end of each work-day, etc. must be followed. The water from the blasting operation and paint debris must be collected, tested, managed and disposed of in accordance with all Federal, State and Air Force rules and regulations.
- Contact the ESC at 476-2310 for additional information on the management of potential hazardous waste.

The proposed activities may require or generate small quantities of hazardous materials or wastes. All wastes generated by the contractor must be managed in accordance with all Federal, State, local and Installation regulations and directives. The contractor will be responsible for sampling all wastes to determine whether they are hazardous or non-hazardous. Results of laboratory analyses must be provided to the Contracting Officer. All containers utilized for the management of wastes must be new and meet the Department of Transportation's performance-oriented packaging requirements. All containers must be labeled to accurately reflect the contents. All other requirements identified in Appendix F of OPLAN 19-14 must be met. The contractor will assume all liabilities for improper waste disposal. The responsibility for off-site disposal of solid non-hazardous waste also lies with the contractor. Management of hazardous waste must be completed in accordance with 40 CFR 260-279. All Air Force hazardous waste is to remain on the Installation and will be shipped off-site by the Air Force under their EPA identification number.

CCAFS has areas of soil and groundwater contamination due to historical activities at various launch complexes. The Cape Installation Restoration Program (45 CES/CEVR) office must review any proposed work for guidance related to contaminated areas.

Prior to any digging, an Excavation Permit will be required. To obtain an excavation permit, contact SGS Mission Support, Excavation Administrator, at 861-3608.

Any proposed real property transaction will require the completion of an Environmental Baseline Survey (EBS).

The proposed project has the potential to adversely impact CCAFS environmental attributes and does not qualify for a Categorical Exclusion (CATEX), as defined in 32 CFR 989, Appendix B. Therefore, further environmental analysis is required (e.g., Environmental Assessment or Environmental Impact Statement).

APPENDIX C

ACTA Technical Report No. 07-630/1-01

SpaceX Falcon 9 Launch Vehicle Debris Characterization

Purchase Order No. 16992

Prepared by

Randolph L. Nyman

Robert Eleazer

ACTA, Inc.
2790 Skypark Drive Suite 310
Torrance, CA 90505

June 2007

This Page Intentionally Left Blank

TABLE OF CONTENTS

<u>Section</u>	<u>Page</u>
1 INTRODUCTION	11
1.1 Executive Summary	14
2 VEHICLE BREAKUP BY FTS DESTRUCT ACTION.....	15
2.1 Debris Assuming FTS Action Explodes Both Stage 1 and Stage 2 Tanks	16
2.1.1 FTS Action Debris Modeling Assumptions and Methodologies	16
2.1.2 FTS Action Debris List Summary	19
2.2 Debris Assuming Explosive Failure Near Stage-1 Separation Time.....	23
2.2.1 Stage Separation Time Modeling Assumptions and Methodologies	23
2.2.2 Stage Separation Time Debris List Summary	23
2.3 Debris Assuming FTS Action Explodes Stage 1 but Stage 2 Remains Intact.....	25
2.3.1 FTS Action with Intact Upper Stage Debris Modeling Assumptions and Methodologies	25
2.3.2 FTS Action with Intact Upper Stage Debris List Summary	28
2.4 Debris Assuming Aerodynamic Breakup of the Falcon 9 Vehicle.....	30
2.4.1 Aerodynamic Breakup Debris Modeling Assumptions and Methodologies ...	31
2.4.2 Aerodynamic Breakup Debris List Summary	34
3 REFERENCES	37

This Page Intentionally Left Blank

LIST OF FIGURES

<u>Figure</u>	<u>Page</u>
Figure 1-1. The Falcon 9 is a 2-Stage Liquid Propellant Launch Vehicle.	12
Figure 1-2. The Falcon 9 First Stage Thrust Section Uses Nine Merlin Liquid Propellant Engines	13
Figure 2-1. Proposed Falcon 9 Flight Termination System Design with Linear Shaped Charges Placed on the Stage 1 Propellant Tanks.....	15
Figure 2-2. Falcon 9 Estimated Basic Casualty Area Relative to Trends Observed in Other Expendable Vehicles With Estimates Produced by a Variety of Vendors.	21
Figure 2-3. Postulated Consequence of Aerodynamic Load Failure in the Falcon 9 Interstage Region Leading to Propellant Mixing and Explosion in the Interstage.....	30

This Page Intentionally Left Blank

LIST OF TABLES

<u>Table</u>	<u>Page</u>
Table 2-1. Summary of Falcon 9 Debris Characteristics Assuming FTS Action Results in Stage 1 and Stage 2 Explosions.	20
Table 2-2. Summary of Falcon 9 Debris Characteristics Assuming Reduced Explosive Energy in a Stage 1 Explosive Failure Just Prior to Stage Separation.	24
Table 2-3. Summary of Falcon 9 Debris Characteristics Assuming FTS Action Results in Stage 1 Explosion and Intact Stage 2 Propellant Tanks.	29
Table 2-4. Summary of Falcon 9 Debris Characteristics Assuming Aerodynamic Loads Buckle the Interstage Resulting in an Explosion in the Interstage Region.	34

This Page Intentionally Left Blank

ACKNOWLEDGEMENTS

The work reported in this document was performed under contract to SpaceX under Purchase Order 16992.

We thank the SpaceX Falcon 9 development team for the information gathered in response to numerous questions asked by ACTA in the course of reviewing and evaluating mass properties spreadsheets and design drawings. Mr. Eric Hultgren and Mr. Hans Koenigsmann of SpaceX were especially helpful in providing a working interface with ACTA and sharing their design expertise concerning locations of strong and weak structural points in the Falcon 9 design.

This Page Intentionally Left Blank
Equation Section (Next)

1 INTRODUCTION

SpaceX is developing the Falcon 9 heavy launch booster capable of placing a 21000-pound payload into low earth orbit. Cape Canaveral, Florida is being considered as a possible launch site for this vehicle. Air Force Space Command Manual 91710, Volume 2 [1], requires SpaceX to deliver the following data product to the 45th Space Wing range safety organization:

“Fragment listings and characteristics for all potential modes of vehicle breakup are required. At a minimum, the following modes of vehicle breakup shall be considered: (1) breakup due to FTS activation, (2) breakup due to an explosion, and (3) breakup due to aerodynamic loads, inertial loads, and atmospheric re-entry heating. Fragmentation data is required up to thrust termination of the last stage that carries a destruct system. All fragments shall be included; however, similar fragments can be accounted for in fragment groups.”

Debris data developed in compliance with AFSPCMAN 91-710 also satisfies FAA requirements.

This document presents estimated debris lists for the Falcon 9 launch vehicle for Flight Termination System (FTS) activation, explosion and aerodynamic breakup modes. Debris estimates were developed in cooperation with SpaceX using design drawings, spreadsheets and mass properties reports representing the vehicle design concept as defined in May 2007. Some features of the vehicle upper stage, avionics bay and re-entry heat shield systems were not yet fully designed as of this reporting period. For those systems this analysis used allocated weight budgets and preliminary design concepts where available. It is ACTA’s opinion that the Falcon 9 vehicle design data was sufficiently mature to provide a very reasonable preliminary debris list. It is anticipated that only minor changes will be required to adjust the debris lists to accommodate the final vehicle design and actual weights.

The Falcon 9 is a 178-foot tall, 12-foot diameter 2-stage launch vehicle that uses LOX and RP-1 propellants in both stages and is depicted in Figure 1-1. The Falcon 9 first stage is powered by 9 Merlin engines as illustrated in Figure 1-2.

The current design weight budget is summarized as follows:

- First Stage Inert Weight 28326 lb
- Second Stage Inert Weight 7091 lb
- Payload Fairing (45.5’ x 17’) Inert Weight 5182 lb
- First Stage LOX 367813 lb
- First Stage RP1 167188 lb
- Second Stage LOX 70099 lb
- Second Stage RP1 29829 lb

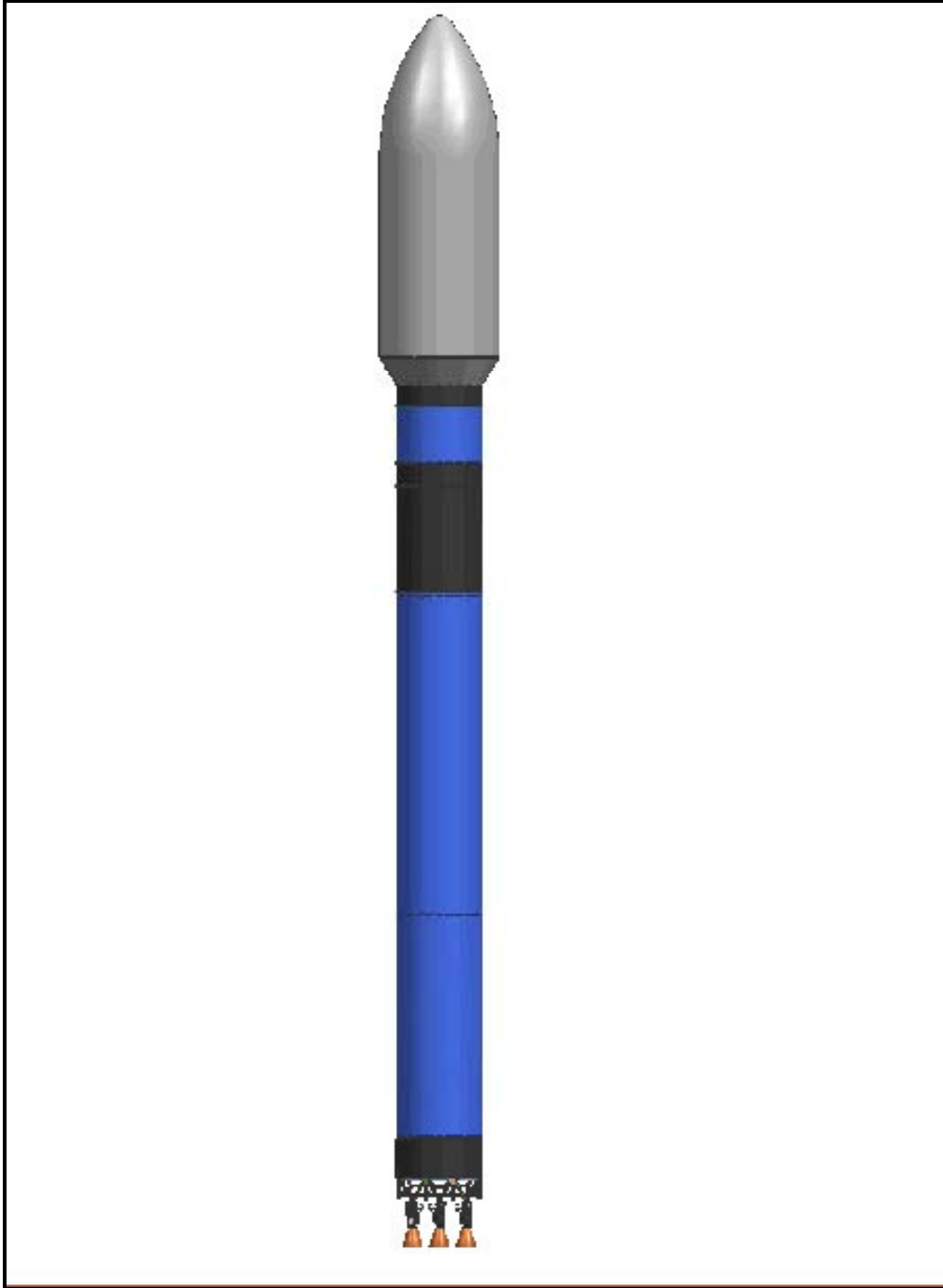

Figure 1-1. The Falcon 9 is a 2-Stage Liquid Propellant Launch Vehicle.

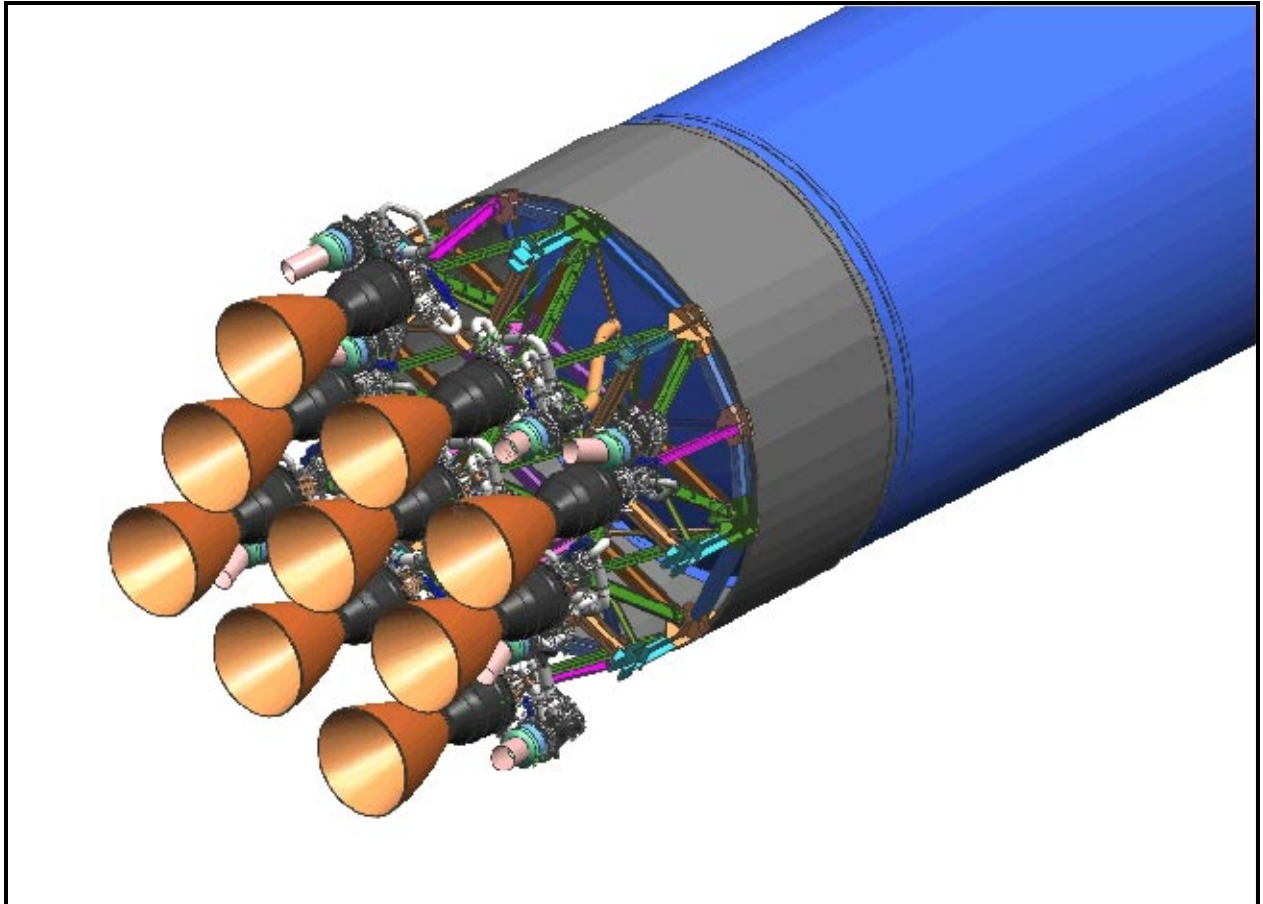

Figure 1-2. The Falcon 9 First Stage Thrust Section Uses Nine Merlin Liquid Propellant Engines

The first and second stage propellant tanks are fabricated from aluminum. The thrust section support frame is comprised of aluminum members. The payload fairing, interstage and thrust section skirt are fabricated from composite materials.

The following sections of this report present the assumptions and methodologies used to develop vehicle fragmentation debris lists for the various breakup modes that were evaluated.

1.1 Executive Summary

Falcon 9 design drawings, material lists and mass properties spreadsheets provided by SpaceX were review and evaluated to develop vehicle fragmentation debris lists for a range of possible vehicle failure modes and failure times. Characterization of fragment properties involved a combination of manual allocations and computer breakup simulations. In general the stage 1 and stage 2 tank breakups given an explosion in the tank due to activation of the flight termination system (FTS) linear shaped charges were estimated using ACTA's MSD (Fragment Mass Distribution) computer model. Other vehicle components in the thrust section, interstage, avionics bay, and payload fairing were broken up "manually" using engineering judgment applied to design drawings and based on discussions with SpaceX designers. The manually defined fragments were added to the MSD predicted tank fragments and the entire debris list was processed with ACTA's LFRAG computer model to predict explosion induced fragment velocity perturbations. This type of analysis was applied to two possible FTS failure modes where in one case both stage 1 and stage 2 tanks are assumed to explode in response to FTS activation and in the other case stage 2 was assumed to survive the FTS destruct action. A scenario involving vehicle explosion near stage 1 separation time was evaluated where the explosive energy in stage 1 was reduced relative to earlier flight times. An Aerodynamic breakup mode was also evaluated wherein it was assumed that the vehicle fails at the interstage creating an explosion in the interstage region involving the forward and aft portions of stage 1 and stage 2 respectively. Approximately 150 fragment groups and 2000 to 4000 fragments were defined in the analyses. Similar classes of fragments can be grouped from this more detailed data set. This report presents a summary of methodologies applied, assumptions made and results. Detailed Excel spreadsheets containing the full information for the debris lists will be provided in soft copy form to SpaceX as the numbers of columns and rows of data were too extensive to conveniently capture in hardcopy format in this report. The report does provide a reduced summary of each data set where debris characteristics are presented for major functional sections of the Falcon 9 vehicle.

2 VEHICLE BREAKUP BY FTS DESTRUCT ACTION

The purpose of a Flight Termination System is to provide a highly reliable means of terminating powered flight of an errant launch vehicle and to ensure breakup of the vehicle to disperse contained propellants that could otherwise result in large explosions if allowed to impact the ground intact. A typical FTS is comprised of both flight hardware elements (command receivers, safe and arm devices, shaped charges and associated wiring) and a ground component (command transmitters, tracking and Missile Flight Control Officer (MFCO)). There is an inherent time delay in FTS action due to MFCO display refresh rate, reaction time and signal transmission such that it is possible intact vehicle or stage impacts could occur in the first 5 seconds or so of powered flight. The Range generally evacuates an area around the launch site to minimize risk from such an event, but damage to neighboring assets could be also be a factor. The design of the Falcon 9 FTS has a significant effect on the debris list generation. As of this writing the proposed FTS design calls for two linear shaped charges to be placed on the stage 1 tanks, one near the common dome bulkhead between the fuel and oxidizer and other at the base of the fuel tank near the thrust section as shown in Figure 2-1. The proposed FTS does not include placing shaped charges on the stage 2 tanks, rather, the intended FTS action for stage 2 flight is to command engine shut down to terminate thrust. This design allows for the possibility that the stage 2 propellant tanks could survive a stage 1 destruct action early in flight and impact the ground in the launch area with all, or nearly all, of the propellant load still in the tanks resulting in an explosion. This study did not attempt to estimate the probability of such an event, however, a debris list considering a largely intact upper stage was developed to support risk analyses of such an event.

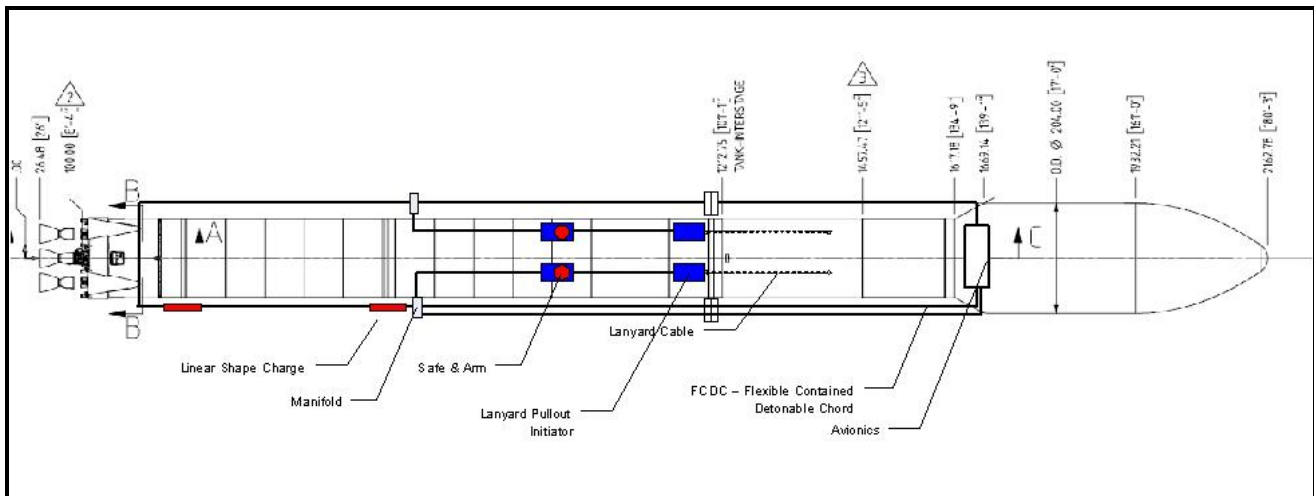

Figure 2-1. Proposed Falcon 9 Flight Termination System Design with Linear Shaped Charges Placed on the Stage 1 Propellant Tanks.

2.1 Debris Assuming FTS Action Explodes Both Stage 1 and Stage 2 Tanks

Although the current FTS design calls for positive destruct action only on stage 1, there is a possibility that SpaceX may consider a design option to place destruct charges on the second stage as well. There is also the possibility that fragments ejected from a stage 1 explosion initiated by destruct action could impact and rupture the second stage propellant tanks resulting in a sympathetic secondary explosion in the upper stage.

2.1.1 FTS Action Debris Modeling Assumptions and Methodologies

This section presents the assumptions and methodologies applied to estimate fragmentation characteristics given multiple explosion locations on the Falcon 9 vehicle. This scenario produces the highest degree of vehicle breakup. The following assumptions and methodologies were applied to this scenario:

1. Explosions occur where fuel and oxidizer can come in close contact and are at least partially confined
2. Explosion locations were assigned at the following station locations:
 - a. Station 273 – mid point of linear shaped charge on stage 1 fuel tank ruptures fuel tank wall and main LOX feed line allowing fuel and oxidizer to mix.
 - b. Station 620 – upper linear shaped charge on stage 1 tank ruptures the common dome bulkhead allowing fuel and oxidizer to mix.
 - c. Station 1503 – assumes shock and/or fragments from stage 1 explosion ruptures common bulkhead dome inside stage 2 allowing fuel and oxidizer to mix.
3. Fraction of LOX and RP1 mixed in the detonation reaction was assumed to be 0.01876 based on ACTA's calculation of the average explosive yield of 3.24% for a single large scale LO2/RP-1 Confined By Missile Project PYRO test involving 94000 pound of propellant [2].
4. Energy of detonation calculation for stage 1 (using PYRO inferred reaction fraction):
 - a. $E = (0.01876)(167188 \text{ lbm})(453.5924 \text{ g/lbm})(4.398 \text{ g/g})(7909.59 \text{ J/g}) = 4.95\text{E}10 \text{ J}$.
5. Adjusted energy of detonation down by a factor of 2 to account for tank length to diameter ratio. PYRO L/D \simeq 4, whereas Falcon 9 stage-1 tank L/D \simeq 8, thus adjusted energy of detonation used for stage 1 was:
 - a. $E = 0.5 * 4.95\text{E}10 \text{ J} = 2.47\text{E}10 \text{ J}$.

6. Energy of detonation calculation for stage 2 was (no adjustment for L/D needed or used):
 - a. $E = (0.01876)(29829 \text{ lbm})(453.5924 \text{ g/lbm})(4.398 \text{ g/g})(7909.59 \text{ J/g}) = 0.88\text{E}10 \text{ J}$.
 - b. The total effective mechanical energy of detonation and the post-shock particle velocity were computed using the chemical thermodynamic equilibrium code Cheetah [3].
7. Fragment mass distribution was computed for the stage 1 and stage 2 tanks assuming independent explosions. This was accomplished using the total energies estimated in items 5 and 6. The detonation energy values and tank material properties are input to the fragment predictive code MSD (MSD is based on a similar code IMPACT with its fragment mass distribution model modified as recommended in Section 5.2.1 of [4]).
8. The ACTA LFRAG model was used to predict explosion induced velocities imparted to the MSD predicted tank fragments.
 - a. MSD generated fragments are inherently defined as rectangular fragments. The average thickness of each fragment category was reduced while retaining the original number of fragments, length to width aspect ratio, fragment mass and fragment kinetic energy in order to increase the area of the fragments to sum to approximately that of the known tank surface area.
 - b. LFRAG and MSD were derived from The Aerospace Corporation IMPACT model, which has been used to model vehicle breakup for both hypervelocity intercepts and vehicle explosions.
 - c. Peak fragment velocities are determined using the conservation of energy relationship where chemical energy is converted to fragment kinetic energy:

$$\frac{M_i V_i^2}{2g_c} = E f \left\{ \frac{\frac{A_i}{d_i}}{\left[\left(\sum_{i=1}^n \frac{A_i}{d_i} \right) + \frac{A_{\text{tank}}}{d_{\text{prop}}} \right]} \right\}$$

Where: V_i = Explosion velocity imparted to i^{th} fragment [ft/sec]

M_i = Mass of i^{th} fragment [lbm]

g_c = English units conversion factor = 32.2 [ft lbf/lbf sec²]

E = Energy released in propellant initiating explosion [ft lbf]

f = Explosion efficiency factor for converting energy in expanding combustion gases to fragment acceleration (typically set at 1%)

A_i = Projected area of i^{th} fragment [ft²]

d_i = Distance from i^{th} fragment location to center of explosion [ft]

A_{tank} = Surface area of propellant tank [ft²]

d_{prop} = Distance from propellant location to center of explosion [ft] (set at $\frac{1}{2}$ the tank radius)

Note: The term in brackets on the right side of the equation allocates the proportion of total imparted kinetic energy to the individual fragments in proportion to the fragment area and inverse distance from the center of the explosion. Fragments with a larger surface area will receive a relatively higher fraction of kinetic energy and fragments farther removed from the center of explosion will receive a relatively lower fraction of kinetic energy. The tank terms account for energy absorbed in dispersing the remaining unreacted liquid propellants.

- d. Fragment mass is partitioned into bins and cumulative mass distribution coefficients for an exponential function are solved iteratively. The extent of breakup increases as the user provided detonation energy increases.
9. Other vehicle fragments (e.g. engine components, interstage walls, avionics bay, payload fairing etc.) were defined “manually” by inspection of design drawings, parts lists and discussions with SpaceX designers. Some general assumptions pertaining to these other parts were:
- a. Engine nozzles will break off.
 - b. Turbo pump and gas generator could come loose from engine.
 - c. Thrust structure is robust and will stay together.
 - d. Propellant feed lines will be broken up to some extent and ejected from the thrust structure.
 - e. Thrust chambers will likely remain attached to thrust structure.

- f. Aft skirt is heavy duty composite (20 layers) and will most likely separate from thrust structure as a relatively small number of larger pieces.
 - g. Reaction control and pressurization spheres will break loose from mounts and be ejected as intact spheres.
 - h. Interstage will likely breakup into many pieces.
 - i. Payload fairing will tend to separate at designed separation points but will likely break into many smaller pieces shortly thereafter.
 - j. Avionics boxes are likely to come loose and will probably tear up the relatively lightweight isogrid mounting plates to which they are attached.
 - k. Stage 2 Columbian nozzle is likely to break into many pieces (no pieces were found after Falcon 1 explosion at Kwajalein).
 - l. Payload likely to remain largely intact.
10. Explosion induced velocities for the manually developed list of “other” fragments were computed by adding the fragment list with mass and shape characteristics to the MSD generated tank debris.

2.1.2 FTS Action Debris List Summary

Detailed spreadsheets have been generated that characterize many of the parameters required for future debris impact and risk calculations, including:

- 1. Fragment description.
- 2. Number of fragments per group.
- 3. Fragment shape.
- 4. Fragment weight.
- 5. Fragment length, width, thickness or radius dimensions.
- 6. Fragment maximum projects area.
- 7. Fragment reference area for ballistic coefficient calculation (assumes fragments tumble during freefall).
- 8. Subsonic drag coefficient (for low Mach number fraction near terminal velocity).

9. Supersonic ballistic coefficient (average value but not necessarily representative of peak values seen near Mach 1 transition).
10. Incremental fragment velocity induced by breakup explosion.
11. Terminal fragment velocity based on air density near sea level.
12. Fragment vertical station number and radial distance from vehicle centerline axis.

Since the Falcon 9 is an all-liquid propellant vehicle there are no solid propellant fragments and no contained propellant fragments in this scenario where all propellant tanks are assumed to have ruptured. All fragments are inert debris and characteristic values are summarized in Table 2-1.

Table 2-1. Summary of Falcon 9 Debris Characteristics Assuming FTS Action Results in Stage 1 and Stage 2 Explosions.

Vehicle Section	Number of Fragments	Fragment Weight Range [lbm]	Fragment Ballistic Coefficient Range [psf]	Fragment Imparted Velocity Range [ft/sec]	Fragment Area Range [ft ²]
Thrust section	1	7047	406	107	134.1
Stage 1 nozzles	9	131.8	41.7	52	6.87
Engine and propellant line parts	91	1.2 – 213.6	6.7 – 89.7	48.4 - 300	0.4 – 5.0
Thrust skirt panels and doors	8	10 - 175	11.4 – 15.1	107 - 624	2.4 – 61.2
Thrust section heat shield	175	0.5 – 32.5	10.9 – 16.2	58.9 – 194.5	0.12 – 7.7
Nacelle covers	4	38.0	7.6	244.6	13.1
Stage 1 tank fragments	1406	0.02 – 110.2	7.1 – 14.3	1384 – 29.6	0.01 – 31.4
Stage 1 Helium bottles	8	70.3	52	15.3	3.1
Interstage composite fragments	977	0.3 - 40	5.1 – 7.4	116.9 – 770.5	0.16 – 21.1
Stage 1 parachute housing	1	840	75.9	20.5	9.0
Interstage batteries	2	30	74	18.0	0.48
Stage 2 engine assembly	1	653.7	181.6	61.2	8.0
Stage 2 nozzle pieces	126	0.5 – 50.0	7.1 – 7.4	145.2 – 365.4	0.28 – 27.6
Stage 2 engine parts and feed lines	13	16 – 417.1	30.2 – 89.7	14.3 – 318.6	0.5 – 4.3
Stage 2 fore and aft structural rings	12	12.0 – 17.2	13.0 – 13.2	347.8 – 723.2	3.7 – 5.2
Stage 2 tank fragments	526	0.02 – 110.2	6.9 – 14.2	176 - 868	0.01 – 31.6
Payload adaptor	1	1124.4	52.1	73.7	48.0
Reaction control tanks	2	22.5	15.1	106.1	3.46
Avionics pieces	16	9.3 – 36.3	32.2 – 89.4	54.3 – 72.6	0.18 – 0.48
Stage 2 Helium bottles	4	70.3	52	141.5	3.1
Stage 2 parachute housing	1	200	19.2	173.1	12.3
Payload fairing pieces	1081	0.4 – 94.1	6.4 – 56.7	13.2 – 330.8	0.19 – 52.0
Space Station MPLM Payload	1	17746	125.2	27.5	315.0

The debris list summarized in Table 2-1 represents the most complete breakup of the Falcon 9 vehicle during first stage flight. Figure 2-2 indicates that the total basic casualty area computed using the destruct breakup list is approximately consistent with the historical ELV trend line. The total number of hazardous fragments estimated for the Falcon 9 command destruct case is 4316, which is about a factor of two higher than the ELV trend. There are several groups of small tank skin fragments representing 150 pieces with a total mass of approximately 5 pounds that are deemed to be non-hazardous based on having a terminal velocity kinetic energy less than 11 foot-pounds. The average weight per fragment, excluding the postulated NASA Multi-Purpose Logistics Module (MPLM) payload, is 9.09 pounds. The average fragment weight including the payload is 13.06 pounds. The average casualty area per hazardous fragment is 8.91 square feet. The average casualty area per pound is calculated to be 0.66 square feet per pound.

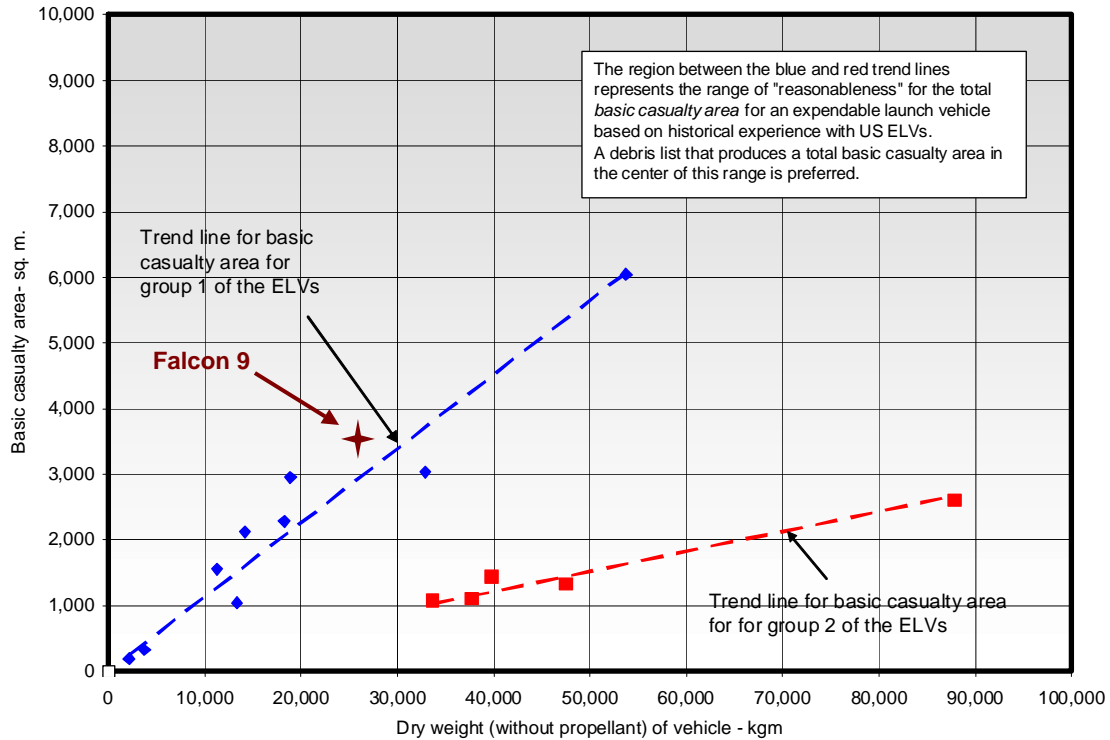

Figure 2-2. Falcon 9 Estimated Basic Casualty Area Relative to Trends Observed in Other Expendable Vehicles With Estimates Produced by a Variety of Vendors.

SpaceX simulated trajectory data for a 185 kilometer circular orbit launched from Kwajalein suggests first stage burn out at about 172 seconds with stage jettison at 174 seconds. ACTA believes that the FTS initiated debris list summarized in Table 2-1 and provided in greater detail in softcopy spreadsheet format, can be applied without modification at 10 second intervals from

t-0 to t+160 seconds. To address the effects of depletion of stage 1 propellant on vehicle breakup near stage 1 separation time, ACTA ran an additional set of analyses using a reduced explosive energy for the first stage. The presumption being that there would be less fuel and oxidizer mixing, particularly near the common bulkhead between the tanks as stage 1 neared burnout. The breakup debris list for a failure near or at stage separation is presented in the next section.

2.2 Debris Assuming Explosive Failure Near Stage-1 Separation Time

ACTA assumed that a less energetic explosion would characterize a stage 1 explosive failure after 160 seconds into flight. The first stage propellant quantity is reduced to less than 6% of the original load at 160 seconds. Explosive reactions are assumed to take place at locations where the fuel and oxidizer liquid phases come into close contact, such as at the common dome between the fuel and oxidizer tank and in the oxidizer feed line that passes through the fuel tank. As propellant is depleted there will be less potential for fuel and oxidizer mixing especially at the common dome, although the lower portion of the oxidizer feed line will likely remain in contact with some residual fuel right up to stage separation. ACTA made a somewhat arbitrary choice to reduce the explosive energy release of the first stage after 160 seconds to 20% of the value used to characterize early flight failures. Thus the assigned explosive energy was 0.494×10^{10} Joules instead of 2.47×10^{10} Joules.

2.2.1 Stage Separation Time Modeling Assumptions and Methodologies

This section presents the assumptions and methodologies applied to estimate fragmentation characteristics given multiple explosion locations on the Falcon 9 vehicle at a time just prior to and at stage 1 separation. Stage 2 was assumed to breakup. The assumptions and methodologies applied to this scenario were the same as those itemized in section 2.1.1 with the following exceptions:

1. The final stage 1 energy of detonation was set at 20% of the value assigned to “full” tanks:

$$E = 0.20 * 2.47E10 \text{ J} = 0.494E10\text{J}$$

2. The reduced energy of explosion was assumed to result in fewer and larger pieces of thrust skirt heat shielding.
3. The reduced energy of explosion was assumed to result in fewer and larger pieces of second stage nozzle and interstage wall breakup.
4. The reduced aerodynamic loads and to a lesser extent the reduced stage 1 explosive energy was assumed to result in fewer and larger pieces of the payload fairing.

2.2.2 Stage Separation Time Debris List Summary

Detailed spreadsheets have been generated for the pre-stage separation explosive scenario that characterizes many of the fragment parameters required for future debris impact and risk calculations and are provided in softcopy format. All fragments are inert debris and characteristic values are summarized in Table 2-2.

Table 2-2. Summary of Falcon 9 Debris Characteristics Assuming Reduced Explosive Energy in a Stage 1 Explosive Failure Just Prior to Stage Separation.

Vehicle Section	Number of Fragments	Fragment Weight Range [lbm]	Fragment Ballistic Coefficient Range [psf]	Fragment Impacted Velocity Range [ft/sec]	Fragment Area Range [ft ²]
Thrust section	1	7047	406	53.2	134.1
Stage 1 nozzles	9	131.8	41.7	26.1	6.87
Engine and propellant line parts	91	1.2 – 213.6	6.7 – 89.7	38.3 – 149.4	0.4 – 5.0
Thrust skirt panels and doors	8	10 - 175	11.4 – 15.1	216 - 311	2.4 – 61.2
Thrust section heat shield	104	0.5 – 32.5	10.9 – 16.2	141 – 178	0.12 – 7.7
Nacelle covers	4	38.0	7.6	294.2	13.1
Stage 1 tank fragments	312	0.02 – 440.9	7.5 – 14.3	12.7 – 689.6	0.01 – 125.8
Stage 1 Helium bottles	8	70.3	52	6.4	3.1
Interstage composite fragments	669	0.47 - 60	5.4 – 7.5	116.8 – 742.8	0.25 – 31.7
Stage 1 parachute housing	1	840	75.9	20.3	9.0
Interstage batteries	2	30	74	17.8	0.48
Stage 2 engine assembly	1	653.7	181.6	59.8	8.0
Stage 2 nozzle pieces	82	0.5 – 80.0	7.1 – 7.4	144.0 – 359.1	0.28 – 27.6
Stage 2 engine parts and feed lines	13	16 – 417.1	30.2 – 89.7	83.5 – 313.7	0.5 – 4.3
Stage 2 fore and aft structural rings	12	12.0 – 17.2	13.0 – 13.2	342.8 – 723.8	3.7 – 5.2
Stage 2 tank fragments	514	0.02 – 110.2	7.4 – 14.3	86.5 - 858	0.01 – 31.5
Payload adaptor	1	1124.4	52.1	73.0	48.0
Reaction control tanks	2	22.5	15.1	105.1	3.46
Avionics pieces	16	9.3 – 36.3	32.2 – 89.4	53.8 – 81.2	0.18 – 0.48
Stage 2 Helium bottles	4	70.3	52	140.5	3.1
Stage 2 parachute housing	1	200	19.2	171.2	12.3
Payload fairing pieces	112	1.7 – 470.8	6.7 – 56.7	13.0 – 325.1	0.78 – 272.2
Space Station MPLM Payload	1	17746	125.2	27.1	315.0

The total number of hazardous fragments estimated for the Falcon 9 explosion near stage separation case is 1916, which is approximately consistent with the ELV trend. There are several groups of small tank skin fragments representing 52 pieces with a total mass of approximately 2 pounds that are deemed to be non-hazardous based on having a terminal velocity kinetic energy less than 11 foot-pounds. The average weight per fragment, excluding the postulated NASA Multi-Purpose Logistics Module (MPLM) payload, is 20.64 pounds. The average fragment weight including the payload is 29.65 pounds. The average casualty area per hazardous fragment is 12.33 square feet. The average casualty area per pound is calculated to be 0.41 square feet per pound. ACTA recommends that the debris list represented in Table 2-2 be applied to failures from 160 seconds to stage 1 separation.

2.3 Debris Assuming FTS Action Explodes Stage 1 but Stage 2 Remains Intact

Since the current FTS design calls for positive destruct action only on stage 1, there is a possibility that the second stage could survive FTS action on the first stage. This type of scenario occurred during the Titan IV A20 mission where the Titan first stage was destroyed but the Centaur upper stage survived and impacted the ocean intact.

2.3.1 FTS Action with Intact Upper Stage Debris Modeling Assumptions and Methodologies

This section presents the assumptions and methodologies applied to estimate fragmentation characteristics given explosion locations on the Falcon 9 first stage only. This scenario is predicted to result in a lesser degree of vehicle breakup in the interstage, avionics bay and payload fairing. The following assumptions and methodologies were applied to this scenario:

1. Explosions occur where fuel and oxidizer can come in close contact and are at least partially confined
2. Explosion locations were assigned at the following station locations:
 - a. Station 273 – mid point of linear shaped charge on stage 1 fuel tank ruptures fuel tank wall and main LOX feed line allowing fuel and oxidizer to mix.
 - b. Station 620 – upper linear shaped charge on stage 1 tank ruptures the common dome bulkhead allowing fuel and oxidizer to mix.
3. Fraction of LOX and RP1 mixed in the detonation reaction was assumed to be 0.01876 based on ACTA's calculation of the average explosive yield of 3.24% for a single large scale LO2/RP-1 Confined By Missile Project PYRO test involving 94000 pound of propellant [2].
4. Energy of detonation calculation for stage 1 (using PYRO inferred reaction fraction):
 - a. $E = (0.01876)(167188 \text{ lbm})(453.5924 \text{ g/lbm})(4.398 \text{ g/g})(7909.59 \text{ J/g}) = 4.95\text{E}10 \text{ J}$.
5. Adjusted energy of detonation down by a factor of 2 to account for tank length to diameter ratio. PYRO $L/D \simeq 4$, whereas Falcon 9 stage-1 tank $L/D \simeq 8$, thus adjusted energy of detonation used for stage 1 was:
 - a. $E = 0.5 * 4.95\text{E}10 \text{ J} = 2.47\text{E}10 \text{ J}$.

6. Fragment mass distribution was computed for the stage 1 tank assuming independent explosions. This was accomplished using the total energy estimated in item 5. The detonation energy value and tank material properties are input to the fragment predictive code MSD (MSD is based on a similar code IMPACT with its fragment mass distribution model modified as recommended in Section 5.2.1 of [4]).
7. The ACTA LFRAG model was used to predict explosion induced velocities imparted to the MSD predicted tank fragments.
 - a. MSD generated fragments are inherently defined as rectangular fragments. The average thickness of each fragment category was reduced while retaining the original number of fragments, length to width aspect ratio, fragment mass and fragment kinetic energy in order to increase the area of the fragments to sum to approximately that of the known tank surface area.
 - b. LFRAG and MSD were derived from The Aerospace Corporation IMPACT model, which has been used to model vehicle breakup for both hypervelocity intercepts and vehicle explosions.
 - c. Peak fragment velocities are determined using the conservation of energy relationship where chemical energy is converted to fragment kinetic energy:

$$\frac{M_i V_i^2}{2g_c} = E f \left\{ \frac{\frac{A_i}{d_i}}{\left[\left(\sum_{i=1}^n \frac{A_i}{d_i} \right) + \frac{A_{\text{tank}}}{d_{\text{prop}}} \right]} \right\}$$

- d. Where:
 1. V_i = Explosion velocity imparted to i^{th} fragment [ft/sec]
 2. M_i = Mass of i^{th} fragment [lbm]
 3. g_c = English units conversion factor = 32.2 [ft lbm/lbf sec²]
 4. E = Energy released in propellant initiating explosion [ft lbf]
 5. f = Explosion efficiency factor for converting energy in expanding combustion gases to fragment acceleration (typically set at 1%)
 6. A_i = Projected area of i^{th} fragment [ft²]

6. d_i = Distance from i^{th} fragment location to center of explosion [ft]
 7. A_{tank} = Surface area of propellant tank [ft²]
 8. d_{prop} = Distance from propellant location to center of explosion [ft]
(set at $\frac{1}{2}$ the tank radius)
- e. *Note: The term in brackets on the right side of the equation allocates the proportion of total imparted kinetic energy to the individual fragments in proportion to the fragment area and inverse distance from the center of the explosion. Fragments with a larger surface area will receive a relatively higher fraction of kinetic energy and fragments farther removed from the center of explosion will receive a relatively lower fraction of kinetic energy. The tank terms account for energy absorbed in dispersing the remaining unreacted liquid propellants.*
- f. Fragment mass is partitioned into bins and cumulative mass distribution coefficients for an exponential function are solved iteratively. The extent of breakup increases as the user provided detonation energy increases.
8. Other vehicle fragments (e.g. engine components, interstage walls, avionics bay, payload fairing etc.) were defined “manually” by inspection of design drawings, parts lists and discussions with SpaceX designers. Some general assumptions pertaining to these other parts were:
- a. Engine nozzles will break off.
 - b. Turbo pump and gas generator could come loose from engine.
 - c. Thrust structure is robust and will stay together.
 - d. Propellant feed lines will be broken up to some extent and ejected from the thrust structure.
 - e. Thrust chambers will likely remain attached to thrust structure.
 - f. Aft skirt is heavy duty composite (20 layers) and will most likely separate from thrust structure as a relatively small number of larger pieces.
 - g. Reaction control and pressurization spheres will break loose from mounts and be ejected as intact spheres.

- h. Interstage will likely breakup into many pieces but with fewer and larger fragments than result if stage 2 also explodes.
 - i. Payload fairing will tend to separate at designed separation points but will likely break into many smaller pieces shortly thereafter with less breakup than for case with stage 2 explosion.
 - j. Avionics trays with attached avionics boxes are likely to come loose with largely intact isogrid mounting plates to which they are attached. Larger avionics boxes will come loose.
 - k. Stage 2 Columbiu nozzle is likely to break into many pieces (no pieces were found after Falcon 1 explosion at Kwajalein).
 - l. Payload likely to remain intact.
9. Explosion induced velocities for the manually developed list of “other” fragments were computed by adding the fragment list with mass and shape characteristics to the MSD generated tank debris.

2.3.2 FTS Action with Intact Upper Stage Debris List Summary

Detailed spreadsheets have been generated that characterize many of the fragment parameters required for future debris impact and risk calculations and are provided in softcopy format. There are no solid propellant fragments in this scenario, however, the stage 2 propellant tanks are assumed to remain intact and to contain the full propellant load at the time of FTS initiation. The second stage engine, nozzle and propellant feed lines are assumed to be broken off from the tank structure and it is possible, perhaps probable, that the stage 2 tank will be venting propellant during free fall. A conservative range safety assumption is to assume that the entire propellant load in stage 2 survives to ground impact resulting in a liquid propellant explosion with some fraction of equivalent TNT (a linear function of impact velocity in ACTA debris risk models). Fragment characteristic values for this scenario are summarized in Table 2-3.

Table 2-3. Summary of Falcon 9 Debris Characteristics Assuming FTS Action Results in Stage 1 Explosion and Intact Stage 2 Propellant Tanks.

Vehicle Section	Number of Fragments	Fragment Weight Range [lbm]	Fragment Ballistic Coefficient Range [psf]	Fragment Imparted Velocity Range [ft/sec]	Fragment Area Range [ft ²]
Thrust section	1	7047	406	119.4	134.1
Stage 1 nozzles	9	131.8	41.7	58.5	6.87
Engine and propellant line parts	91	1.2 – 213.6	6.7 – 89.7	54.1 – 335.4	0.4 – 5.0
Thrust skirt panels and doors	8	10 - 175	11.4 – 15.1	120 - 698	2.4 – 61.2
Thrust section heat shield	175	0.5 – 32.5	10.9 – 16.2	65.9 – 217.5	0.12 – 7.7
Nacelle covers	4	38.0	7.6	273.4	13.1
Stage 1 tank fragments	1406	0.02 – 110.2	7.1 – 14.3	28.5 – 1547.6	0.01 – 31.4
Stage 1 Helium bottles	8	70.3	52	14.4	3.1
Interstage composite fragments	799	0.3 - 40	5.1 – 7.4	44.2 – 76.9	0.16 – 21.1
Stage 1 parachute housing	1	840	75.9	10.1	9.0
Interstage batteries	2	30	74	10.3	0.48
Stage 2 engine assembly	1	653.7	181.6	5.4	8.0
Stage 2 nozzle pieces	52	0.5 – 50.0	7.1 – 7.4	54.7 – 74.0	0.28 – 27.6
Stage 2 engine parts and feed lines	7	16 – 417.1	30.2 – 89.7	5.9 – 21.6	0.68 – 4.3
Stage 2 tank (filled)	1	103503	1155	2.8	113.1
Payload adaptor	1	1124.4	52.1	6.9	48.0
Reaction control tanks (filled)	2	297.5	199.8	5.6	3.46
Avionics pieces	7	20.3 – 138.8	5.1 – 43.5	7.0 – 30.5	0.48 – 60
Stage 2 Helium bottles	4	70.3	52	6.7	3.1
Stage 2 parachute housing	1	200	19.2	11.9	12.3
Payload fairing pieces	162	0.4 – 94.1	6.4 – 56.7	6.5 – 35.8	0.25 – 52.0
Space Station MPLM Payload	1	17746	125.2	5.2	315.0

The debris list summarized in Table 2-3 represents an alternate possible breakup of the Falcon 9 vehicle during first stage flight that leaves the stage 2 tanks intact with fewer and larger debris pieces in the upper stage and payload fairing. ACTA believes that the debris list summarized in Table 2-3 can be applied without modification at 10 second intervals from t=0 to t+174 seconds. In reality there would likely be some effect of propellant depletion on the fraction of propellant involved in an initiating explosion but there are offsetting factors between less propellant mixing later in flight (implying reduced explosion energy and lower induced velocities) and less residual liquid propellant to absorb explosion energy (implying more energy imparted to structural elements and therefore higher induced velocities). The models and methodologies applied in this study are not sufficiently advanced to resolve these details. Such factors are perhaps best treated

as a source of inherent model uncertainty and considered statistically when performing probabilistic debris risk computations.

2.4 Debris Assuming Aerodynamic Breakup of the Falcon 9 Vehicle

Certain vehicle failure modes can cause the vehicle pitch or yaw out of the intended nominal flight trajectory increasing the angle of attack and overloading the structural capability of the vehicle. Typically the maximum load condition is defined in terms of “Q-alpha”, where Q is the dynamic pressure and alpha is the angle of attack. Based on discussions with SpaceX design engineers, it is expected that during first stage flight, exceedance of the Q-alpha limit will result in structural failure in the interstage region of the vehicle.

ACTA postulated an aerodynamic failure sequence as buckling in the interstage region followed by failures of the forward LOX dome of the first stage tank and aft fuel dome of the second stage as indicated in Figure 2-3. Structural failure of the interstage walls would remove the mechanism that transfers stage 1 thrust to the upper stage and the axial thrust forces would tend to drive the forward LOX dome into the stage 2 motor and aft fuel dome of the second stage. It was assumed that 10% of the stage 1 LOX and 5% of the stage two LOX were available to react with 100% of the stage 2 RP-1 leading to an initial explosion in the interstage region.

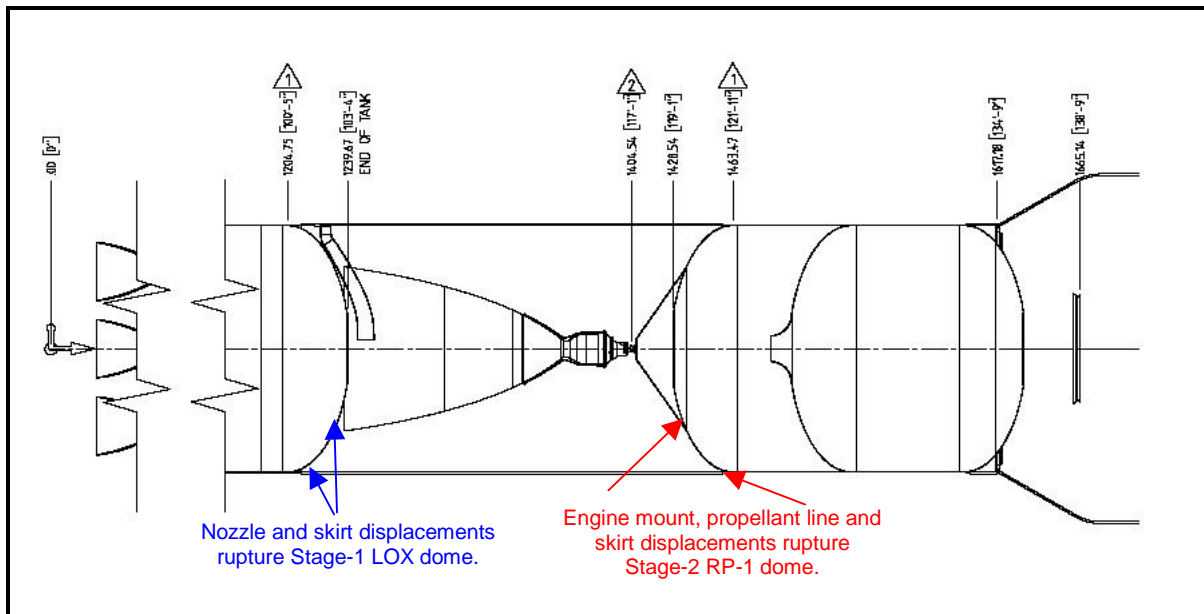

Figure 2-3. Postulated Consequence of Aerodynamic Load Failure in the Falcon 9 Interstage Region Leading to Propellant Mixing and Explosion in the Interstage.

A second possible initiating vehicle breakup sequence exists for an interstage aerodynamic breakup failure mode. The stage 1 FTS design has a lanyard pull FTS activation feature rigged in the interstage (see Figure 2-1) to protect against inadvertent stage separation. Bending in the interstage could pull one or more of the lanyards and activate the stage 1 FTS linear shaped charges. In this event, the debris list for complete vehicle breakup assuming FTS action destroys both stages should be used. The debris list development described in the following paragraphs assumes that an explosion in the interstage following structural failure of the interstage walls drives the aerodynamic failure mode vehicle breakup.

2.4.1 Aerodynamic Breakup Debris Modeling Assumptions and Methodologies

This section presents the assumptions and methodologies applied to estimate fragmentation characteristics given an explosion located in the Falcon 9 interstage region as the vehicle begins to buckle. The following assumptions and methodologies were applied to this scenario:

1. Explosions occur where fuel and oxidizer can come in close contact and are at least partially confined.
2. Explosion location was assigned at the following station location:
 - a. Station 1334 – mid point of interstage 1
 - b. Note: Shortening of the vehicle stack by collapse of the interstage was ignored for the purpose of calculating distances of fragments from the explosion center, which was based on intact vehicle station numbers.
3. Explosion induced fragment velocity perturbations were computed using empirical TNT coefficient methodology applied by The Aerospace Corporation in their development of the Falcon 1 debris list.
4. Energy of detonation calculation was based on the following assumptions:
 - a. Mass of propellant involved in the initiating explosion = 29829 lbm of stage 2 RP-1 + 3505 lbm of stage 2 LOX + 36816 lbm of stage 1 LOX = 70150 lbm total propellant
5. Explosion efficiency factor was set at 0.0003.

6. Breakup of the stage 1 and stage two tanks was estimated manually assuming greater breakup on the tank ends near the explosion with progressively fewer and larger fragments moving to the tank ends farthest from the explosion.
7. The empirical formula applied to estimate explosion induced fragment velocity is:

$$\Delta V_i = \left(f M_{prop} \right)^{1/3} \left\{ 10 \left[a_1 + a_2 X + a_3 X^2 + a_4 X^3 \right] \right\} \left(\frac{A_i g_c}{1000 M_i} \right)$$

Where: ΔV_i = Explosion velocity imparted to i^{th} fragment [ft/sec]

f = Explosion efficiency factor for converting energy in expanding combustion gases to fragment acceleration (typically set at 0.0003)

M_{prop} = Mass of propellant in the explosion [lbm]

a_1 = TNT coefficient = 1.75292

a_2 = TNT coefficient = -0.94952

a_3 = TNT coefficient = 0.112136

$$X = b_1 + b_2 \log_{10} \left(\frac{d_i}{\left(f M_{prop} \right)^{1/3}} \right)$$

a_4 = TNT coefficient = -0.02507

b_1 = empirical coefficient = -0.78195

b_2 = empirical coefficient = 1.3342

d_i = Distance from i^{th} fragment location to center of explosion [ft]

A_i = Projected area of i^{th} fragment [ft²]

M_i = Mass of i^{th} fragment [lbm]

g_c = English units conversion factor = 32.2 [ft lbm/lbf sec²]

1000 = units conversion factor

8. The maximum explosion induced fragment velocity calculated in item 7 is limited to 1500 ft/sec.:
9. All vehicle fragments were defined “manually” by inspection of design drawings, parts lists and discussions with SpaceX designers. Some general assumptions pertaining to these other parts were:
 - a. Engine nozzles will break off.
 - b. Turbo pump and gas generator could come loose from engine.
 - c. Thrust structure is robust and will stay together.
 - d. Propellant feed lines will be broken up to some extent and ejected from the thrust structure.
 - e. Thrust chambers will likely remain attached to thrust structure.
 - f. Aft skirt is heavy duty composite (20 layers) and will most likely separate from thrust structure as a relatively small number of larger pieces.
 - g. Reaction control and pressurization spheres will break loose from mounts and be ejected as intact spheres.
 - h. Interstage will likely breakup into many pieces.
 - i. Payload fairing will tend to separate at designed separation points but will likely break into many smaller pieces shortly thereafter.
 - j. Avionics trays with attached avionics boxes are likely to come loose with largely intact isogrid mounting plates to which they are attached. Larger avionics boxes will come loose.
 - k. Stage 2 Columbia nozzle will be shattered into many pieces as interstage collapses and explosion ensues.
 - l. Payload likely to remain intact.

2.4.2 Aerodynamic Breakup Debris List Summary

Detailed spreadsheets have been generated that characterize many of the fragment parameters required for future debris impact and risk calculations and are provided in softcopy format. There are no solid propellant fragments and no contained liquid propellant tank pieces in this scenario therefore all debris is inert. Fragment characteristic values for this scenario are summarized in Table 2-4.

Table 2-4. Summary of Falcon 9 Debris Characteristics Assuming Aerodynamic Loads Buckle the Interstage Resulting in an Explosion in the Interstage Region.

Vehicle Section	Number of Fragments	Fragment Weight Range [lbm]	Fragment Ballistic Coefficient Range [psf]	Fragment Imparted Velocity Range [ft/sec]	Fragment Area Range [ft ²]
Thrust section	1	7047	406	1.1	134.1
Stage 1 nozzles	9	131.8	41.7	2.8	6.87
Engine and propellant line parts	91	1.2 – 213.6	6.7 – 89.7	0.9 – 19.0	0.4 – 5.0
Thrust skirt panels and doors	8	10 - 175	11.4 – 15.1	14.2 – 21.2	2.4 – 61.2
Thrust section heat shield	175	0.5 – 32.5	10.9 – 16.2	13.3 – 13.6	0.12 – 7.7
Nacelle covers	4	38.0	7.6	19.9	13.1
Stage 1 tank fragments	405	4.5 – 967.4	2.3 – 76.5	1.9 – 225.1	0.01 – 31.4
Stage 1 Helium bottles	8	70.3	52	20.0	3.1
Interstage composite fragments	799	0.3 - 40	5.1 – 7.4	340.7 – 814.7	0.16 – 21.1
Stage 1 parachute housing	1	840	75.9	11.5	9.0
Interstage batteries	2	30	74	12.0	0.48
Stage 2 engine assembly	1	653.7	181.6	16.7	8.0
Stage 2 nozzle pieces	126	0.5 – 50.0	7.1 – 7.4	593 - 1500	0.28 – 27.6
Stage 2 engine parts and feed lines	13	16 – 417.1	30.2 – 89.7	21.5 – 62.3	0.68 – 4.3
Stage 2 fore and aft structural rings	12	12.0 – 17.2	13.0 – 13.2	84.7 – 196.3	3.7 – 5.2
Stage 2 tank fragments	177	7.2 - 200	3.6 – 117.6	13.9 – 320.4	3.8 – 31.3
Payload adaptor	1	1124.4	52.1	11.0	48.0
Reaction control tanks	2	22.5	15.1	38.4	3.46
Avionics pieces	16	9.3 – 36.3	22.8 – 63.3	3.3 – 7.5	0.18 – 0.48
Stage 2 Helium bottles	4	70.3	52	17.4	3.1
Stage 2 parachute housing	1	200	19.2	17.0	12.3
Payload fairing pieces	1081	0.4 – 94.1	6.4 – 56.7	5.7 – 148.1	0.25 – 52.0
Space Station MPLM Payload	1	17746	125.2	3.1	315.0

The debris list summarized in Table 2-4 represents a possible aerodynamic breakup failure mode of the Falcon 9 vehicle during first stage flight that does not activate the stage 1 FTS by the lanyard mechanisms located in the interstage area. ACTA believes that the debris list

summarized in Table 2-4 can be applied without modification at 10 second intervals from t-0 to t+174 seconds and is most applicable to malfunction turn failure modes that result in exceedance of Q-alpha load criteria. In reality there would likely be some effect of propellant depletion on the fraction of propellant involved in an initiating explosion. The models and methodologies applied in this study are not sufficiently advanced to resolve these details. Such factors are perhaps best treated as a source of inherent model uncertainty and considered statistically when performing probabilistic debris risk computations.

This Page Intentionally Left Blank

3 REFERENCES

- [1] Air Force Space Command Manual 91-710 (AFSPCMAN 91-710), Volume 2, "Range Safety User Requirements Manual Volume 2 – Flight Safety Requirements", July 1, 2004.
- [2] Willoughby, A. B., et al., "Liquid Propellant Explosive Hazards, URS 652-35, AFRPL-TR-68-92, URS Research Company, Dec 1968, Vol. 2, pg 1-53, Test No. 301.
- [3] *Fried, L.E., CHEETAH 2.0 User's Manual*, Lawrence Livermore National Laboratory Document No. UCRL-MA-117541 Rev. 5, University of California at Livermore, August 1998.
- [4] Lambert, R. R., et al., *Program IMPACT Debris Models for Explosions*, Report No. 01-464, ACTA, Inc., Torrance, CA, 30 July 2001.

APPENDIX D

Air Data



ANALYSIS REPORT		NUMBER: 2003-001
		DATE: 17 Februsry 2003
SUBJECT: Exhaust Plume Calculations for Space-X Falcon 60 Engine		PAGE 1 OF 3
PREPARED FOR: Thomas Mueller, Space X		NO. OF APPEN. 0
DISTRIBUTION:		(W.O. 6510B)

1.0 SUMMARY

Kinetic calculations were performed to estimate the exhaust constituents of the Space X Falcon 60 LOX-kerosene rocket engine. Although the exit-plane exhaust is fuel-rich and contains high concentrations of carbon monoxide (CO), subsequent entrainment of ambient air results in nearly complete conversion of the CO into carbon dioxide (CO₂). The CO emission for the Falcon 60 is conservatively predicted to be between 0.25 and 0.30 lb_m/s under full power operation. No significant nitrogen oxide (NO_x) production is predicted.

2.0 ANALYSIS APPROACH

The analysis of the Falcon 60 exhaust plume started using the one-dimensional equilibrium (ODE) solution for the Falcon engine. The ODE module of the JANNAF standard nozzle performance prediction code TDK was used to calculate the engine exit plane exhaust composition. The calculations were performed for liquid oxygen (LOX) and kerosene propellants at a combustion chamber pressure of 650 psia, an engine O/F mixture ratio (MR) of 2.25 and nozzle expansion ratio of 12:1. The predicted exhaust characteristics are as follows:

Equilibrium Exit Plane Predictions

Pexit (psia)	82
Texit (R)	3351
Species Mole Fractions	
CO	34%
CO ₂	17%
H ₂ O	33%
H ₂	16%

The subsequent analysis used the one-dimensional kinetics model of the TDK package to determine the after-burning characteristics of the exhaust plume as ambient air is entrained. The calculations were performed assuming constant pressure (50 psia) and entrainment of ambient temperature air. Detailed plume entrainment calculations were not available. The problem was bounded by examining the CO burn-out with the entrainment of 10 and 40 volumes of air, i.e. the air is mixed in until 10 or 40 times the initial volumetric flow rate of air is entrained into the exhaust plume (Figure 1). The following two tables summarize the calculation results.

10X Air Volumetric Flow Rate Entrained

Volumetric flow rate of air entrained (ft ³ /s)	89,290
Mass flow rate of air entrained (lb _m /s)	6608
Final CO concentration (ppm)	142
Final CO mass flow rate (lb _m /s)	0.336

40X Air Volumetric Flow Rate Entrained

Volumetric flow rate of air entrained (ft ³ /s)	357,140
Mass flow rate of air entrained (lb _m /s)	26,429
Final CO concentration (ppm)	27
Final CO mass flow rate (lb _m /s)	0.407

Comparisons of the entrained flows with plume flowfield predictions for a similar engine show that the entrained flows are conservative (below), with the 10X and 40X cases similar to the reference plume 100 and 300 ft downstream of the nozzle exit, respectively.

Entrainment Predictions for Similar Engine

Downstream Distance (ft)	Mass flow rate of air entrained (lb _m /s)
25 (10 exit diameters)	592
100 (40 exit diameters)	6,559
150 (60 exit diameters)	13,021
300 (120 exit diameters)	36,623

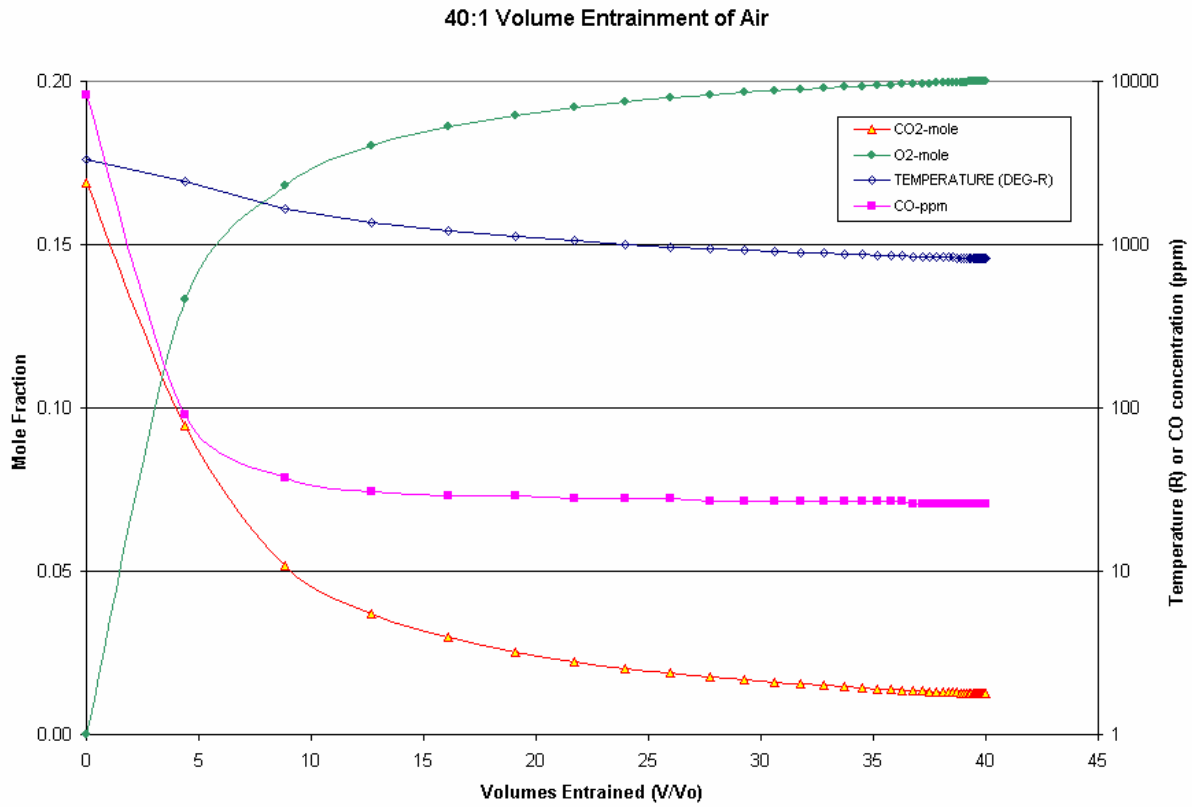

Figure 1: Predicted Bulk Plume Temperature and Species Concentration versus Air Entrainment

Federal Regulatory Framework

Air quality at CCAFS, KSC, and VAFB is regulated Federally under Title 40 CFR 50 (National Ambient Air Quality Standards [NAAQS]), Title 40 CFR 51 (Implementation Plans), Title 40 CFR 61 and 63 (National Emission Standards for Hazardous Air Pollutants [NESHAPs]), and Title 40 CFR 70 (Operating Permits).

The National Primary Ambient Air Quality Standards define the levels of air quality necessary to protect the public health with an adequate margin of safety. The National Secondary Ambient Air Quality Standards define levels of air quality necessary to protect the public welfare from adverse effects of a pollutant. There are standards for ozone, carbon monoxide (CO), oxides of nitrogen (NOX), sulfur dioxide (SO₂), particulate matter equal to or less than 10 microns in diameter (PM₁₀), and lead. An area with air quality better than the NAAQS is designated as being in attainment while areas with worse air quality are classified as non-attainment areas.

Federal actions are required to conform to any State Implementation Plan approved or promulgated under Section 110 of the Clean Air Act (CAA). A conformity determination is required for each pollutant resulting from a Federal action for which the total of direct and indirect emissions in a non-attainment or maintenance area would equal or exceed de minimis thresholds (listed in Title 40 CFR 51.853). De minimis is Latin for "of minimum importance" or "trifling." Essentially de minimis thresholds refer to values so small that the law will not consider them.

NESHAPs regulate hazardous air emissions from stationary sources. The U.S. EPA lists emission standards for specific types of stationary sources. These standards are referred to as Maximum Available Control Technology (MACT) standards. The only section of the NESHAPs regulations that applies to the proposed activity is Title 40 CFR 63 Subpart GG, which applies to facilities that manufacture or rework commercial, civil, or military aerospace vehicles or components and that are major sources of hazardous air pollutants (HAPs).

Title V of the Clean Air Act Amendments (CAAA) of 1990 requires all major sources to have an operating permit. This permit incorporates all applicable Federal requirements under the CAA. A major source is defined as one that can: (1) emit 90.7 metric tons (100 tons) per year of any regulated air pollutant within an area that is in attainment for that pollutant; (2) emit 9.1 metric tons (10 tons) per year of any one of the 189 HAPs; or (3) emit 22.7 metric tons (25 tons) per year of total HAPs. The major source thresholds can be lower if the source is in a non-attainment area for a pollutant.

Title 40 CFR 82 seeks to prevent damage to the ozone layer by Class I and Class II Ozone-Depleting Substances (ODSs). It contains subparts addressing production and consumption controls, servicing of motor vehicle air conditioners, bans on nonessential products, Federal procurement, recycling and emissions reduction, and alternative compounds.

State of Florida Regulatory Framework

Air quality for the CCAFS area is regulated under Rule 62-200 et seq., Florida Administrative Code (F.A.C.). As shown in Table 3.5-1, the Florida Ambient Air Quality Standards (FAAQS) are not significantly different from the NAAQS. Specific regulations that may be applicable to

launch complex activation activities include Rule 62-204.240, F.A.C. (Florida Ambient Air Quality Standards [FAAQS]), Rule 62-210, F.A.C. (Stationary Source General Requirements) establishes general requirements for stationary sources of air pollutant emissions and provides criteria for determining the need to obtain an air construction or air operation permit., Rule 62-212, F.A.C. (Stationary Source Preconstruction Permitting), Rule 62-213, F.A.C. (Operating Permits), and Rule 62-242, F.A.C. (Mobile Sources). CCAFS and KSC are classified as major sources because emissions are above major source thresholds. KSC and CCAFS have Title V permits.

The FDEP, Division of Air Resources Management, has primary jurisdiction over air quality and stationary source emissions at CCAFS. Stationary source emissions at CCAFS include abrasive blasting, external/internal combustion sources, degreasing operations, storage tanks, rocket fuel sources, landfill operation, vegetation burning, fuel dispensing, woodworking, welding operations, surface coating operations, water treatment plant operations, asphalt paving operation and miscellaneous general process operations.

Rule 62-204, F.A.C. (Air Pollution Control – General Provisions). This rule establishes the ambient air quality standards for Florida, the maximum allowable increases in ambient concentrations for subject pollutants to prevent significant deterioration of air quality, designates the areas of the state as attainment, non-attainment, or unclassifiable and classifies areas of the state as Class I, Class II or Class III for determining which prevention of significant deterioration increments apply.

Rule 62-210, F.A.C. (Stationary Source General Requirements). This rule establishes general requirements for stationary sources of air pollutant emissions and provides criteria for determining the need to obtain an air construction or air operation permit. It establishes public notice and reporting requirements and requirements relating to estimating emission rates and using air quality models. This chapter also sets forth special provisions related to compliance monitoring, stack heights, circumvention of pollution control equipment, and excess emissions reporting.

Rule 62-212, F.A.C. (Stationary Source Preconstruction Permitting). The preconstruction review requirements for proposed new emissions units or facilities and proposed modifications are established in this rule. The requirements of this chapter apply to those proposed activities for which an air construction permit is required. This chapter includes general pre-construction review requirements and specific requirements for emissions units subject to PSD and non-attainment area preconstruction review. It also includes preconstruction review requirements applicable to specific emissions unit types.

Rule 62-213, F.A.C. (Operating Permits). This rule implements Federal Regulation 40 CFR 70, which provides a comprehensive operation permit system for permitting “major” sources of air pollution (Title V sources). The amount and schedule of payment of the annual emissions fee are provided. For facilities operating under the terms of Title V air “general permits”, applicability, general procedures and conditions and local air program requirements are explained. Also provided are permit requirements for all Title V sources, changes or modifications allowed at a source without necessitating a permit revision, allowable trading of emissions within a source, permit application compliance, permit issuance, renewal and revision and permit review by the USEPA and any affected states.

CCAFS emissions (as shown in Table 3.5-2 below) from CCAFS are above the major stationary source threshold for several criteria pollutants. Therefore, CCAFS is currently classified as a major stationary source regulated under 40 CFR 70 and Rule 62-213, F.A.C. and operates under a Title V Operating permit issued by FDEP. CCAFS received their initial Title V permit in 1999 and renewed the permit in January 2002; and CCAFS modified their Title V Operating permit with FDEP to obtain a Synthetic Minor (Non-Title V) for HAPs while remaining a “major” facility for other regulated pollutants. CCAFS accepted certain physical and/or operational limitations on certain emissions units. This modification made CCAFS not subject to NESHAP 40 CFR Part 63, Subpart ZZZZ effective 29 November 2005. CCAFS must still document and maintain a log for at least 5 years after this effective date, which includes at least a monthly log, and a consecutive 12 month total of required data concerning VOCs usage and associated HAPs, VOC emissions rates, and single and combined totals for listed HAPs.

The proposed action alternative sites were not specifically addressed in the emissions limitations described in this 2005 HAPs synthetic minor permit modification request. Brevard County currently meets the FAAQS and NAAQS for ozone, SO₂, NO_x, CO, and PM₁₀ and the NAAQS for PM_{2.5}. Because the area is in attainment for these pollutants, the FDEP has not been required to establish specific emission reduction measures for CCAFS, although through Title V Operating Permit recordkeeping requirements, data will need to be estimated from CCAFS including the proposed action related data.

VOCs and HAPs data will need to be estimated, tabulated, and reported with regard to fuel loading, and/or paint and solvent usage, such as facility routine repainting or touchup painting (for paints and solvents that contain VOCs and/or HAPs), and for PM regarding usage of any sandblast media for launch stands refurbishment. This information will be incorporated into the CCAFS annual emissions inventory updates each year as usual.

Upper Atmospheric Area

The concentration (typically parts per million-ppm) and distribution of stratospheric ozone is controlled by various chemical reactions, the most important of which are the catalytic reactions involving nitrogen, chlorine, bromine, and hydrogen compounds known as radicals. The importance of these oxides lies in the fact that they destroy ozone molecules without being destroyed themselves. Small (< m) aerosol particles in the stratosphere (mainly sulfate) also play a role in stratospheric chemistry by providing a surface on which chemical reactions can proceed. Thus even though radicals and particles are present in the unperturbed stratosphere in only relatively small amounts (hundreds to thousands of times less than ozone), they exert a controlling influence on ozone concentrations. Ultimately, this means that relatively small amounts of radicals and particles can sufficiently perturb the stratosphere to cause ecologically substantial ozone loss.

At the present time the ozone layer is characterized by a substantial perturbation caused by the introduction of chlorine and bromine radicals from the photochemical breakdown of man-made halocarbons after they have mixed into the stratosphere. Global ozone loss from halocarbons is thought to be about 4% at the present time (WMO, 1999). Most halocarbon production and use have been banned by international agreement and so the expectation is that the ozone layer would return to normal by about 2050 as the previously released halocarbons are consumed by sunlight and natural processes slowly remove the liberated chlorine and bromine (WMO, 1999). Sufficiently intense

natural events can also cause substantial, though transient, ozone loss. Violent volcanic explosions can inject gases and particles into the stratosphere that reduce ozone.

Solid and liquid rocket propulsion systems emit a variety of gases and particles directly into the stratosphere (WMO, 1991). A large fraction of these emissions, CO₂ for example, are chemically inert and do not affect ozone levels directly. Other emissions such as HCl and H₂O are not highly reactive but they do have an impact on ozone since these gases participate in chemical reactions that help determine the concentrations of the ozone destroying radical gases. A small fraction of rocket engine (solid fuels) emissions are highly reactive radicals. Particulate emissions such as Al₂O₃ (alumina) and carbon (soot) may mimic or enhance the role of natural stratospheric particles by enabling or enhancing ozone-related chemical reactions.

In the environmental impact statement for the EELV Program (U.S. Air Force 1998a), it was determined that emissions from any ozone-depleting substances would not be produced in the stratosphere. Therefore, the emissions from the worst-case scenario would not have any significant impacts in the stratospheric ozone layer.

A process evaluation of the EELV Program and its comparison to the worst-case scenario is presented in Appendix C of "The Final EA for Falcon Launch Program, Vandenberg AFB, 18 July 2003". This analysis discussed how the impact on air quality in the upper atmosphere would likely be less than for the current EELV Program. This conclusion would also hold true for the Falcon Launch Program, for both the proposed site and for both proposed alternative sites for CCAFS.

Greenhouse effect gases such as CO₂ are not presently regulated by the Federal Government or the FDEP, in the lower atmosphere nor the upper atmosphere. CO and CO₂ is produced from all fossil fuel burning sources. Other certain ozone depleting substances not produced by the Falcon Launch Vehicles (such as CFCs) are discussed within Title VI of the CAAA of 1990, and 45th Space Wing, as well as the rest of the USAF, has a proactive Ozone Depleting Substance (ODS) tracking program presently, and complies with provisions within Title VI for lower atmosphere generated sources (such as refrigerants use for air conditioning and cooling units for facilities and for CCAFS motor pool vehicles on-site). Greenhouse gases are thought to potentially have a negative effect on the ozone protective layer of the atmosphere. Research on greenhouse gas production (and possible effects of certain related pollutants, such as contributing to global warming) is ongoing by the USEPA and some states.

APPENDIX E

ASBESTOS DATA

Due to the volume of the asbestos survey material related to SLC 40 facilities, the reader is directed to APPENDIX G of the following document:

Phase I Environmental Site Assessment for the Titan IV Launch Vehicle Program Cape Canaveral Air Force Station, Florida which was prepared for Lockheed Martin Space Systems Company dated July 25, 2005.

APPENDIX F

FALCON NOISE MODELING

⇒ Noise source: **ATLAS HAS MLV10-9/8/01 Launch**
 ⇒ Basic sound level drop-off rate: **6.00** dB/doubling
 ⇒ Atmospheric absorption coefficient: **0.22** dB/100 meters
 ⇒ Reference Level (SEL, Lmax, Leq, Ldn): **118.00** Peak dB
 ⇒ Distance for Reference Noise Level: **32,472.00** Feet
9,978.00 Meters

DISTANCE ATTENUATION:

Receptor Distance (feet)	Lpk Value (dB) at Receptor
100	189.8
200	183.7
300	180.1
400	177.6
500	175.6
600	173.9
700	172.5
800	171.3
900	170.2
1,000	169.2
1,500	165.4
2,000	162.6
3,000	158.4
4,000	155.2
5,000	152.6
5,280	152.0
7,500	147.4
7,920	146.7
9,000	144.8
10,000	143.3
10,560	142.4
13,200	138.7
15,840	135.4
18,480	132.3
21,120	129.3
23,760	126.5
26,400	123.9
29,040	121.3
31,680	118.7
34,320	116.3
36,960	113.9
39,600	111.5
42,240	109.2
44,880	106.9
47,520	104.6
52,800	100.2

DISTANCE TO dB CONTOURS:

Lpk Noise Contour Value (dB)	Contour Distance (feet)
190	97
185	172
180	304
175	534
170	922
165	1,568
160	2,488
155	4,102
150	6,620
145	8,842
140	11,379
135	16,525
130	19,560
125	25,152
120	11,259
115	35,087
110	41,976

Contour distance calculations are most accurate within the decibel range of the direct attenuation calculations.

Except for sounds with highly distinctive tonal characteristics, noise from a particular source will not be identifiable when its incremental noise level contribution is significantly less than background noise levels.

Notes: Drop-off calculations include atmospheric absorption at 0.22 dB/100 meters, centered at the reference distance.

Except for sounds with highly distinctive tonal characteristics, noise from a particular source will not be identifiable when its incremental noise level contribution is significantly less than background noise levels.

Contour distance calculations are most accurate within the decibel range of the direct attenuation calculations.

FALCON STAGE 1 ROCKET

- ⇒ Noise source: **FALCON STAGE 1 ROCKET**
- ⇒ Basic sound level drop-off rate: **6.00** dB/doubling
- ⇒ Atmospheric absorption coefficient: **0.22** dB/100 meters
- ⇒ Reference Level (SEL, Lmax, Leq, Ldn): **145.00** Peak dB
- ⇒ Distance for Reference Noise Level: **200.00** Feet
- ⇒ **60.96** Meters

DISTANCE ATTENUATION:

Receptor Distance (feet)	Lpk Value (dB) at Receptor.
100	151.1
200	145.0
300	141.4
400	138.9
500	136.9
600	135.2
700	133.8
800	132.6
900	131.5
1,000	130.5
1,500	126.7
2,000	123.9
3,000	119.7
4,000	116.5
5,000	113.9
5,280	113.3
7,500	108.7
7,920	108.0
9,000	106.1
10,000	104.6
10,560	103.7
13,200	100.0
15,840	96.7
18,480	93.6
21,120	90.6
23,760	87.8
26,400	85.2
29,040	82.6
31,680	80.0
34,320	77.6
36,960	75.2
39,600	72.8
42,240	70.5
44,880	68.2
47,520	65.9
52,800	61.5

DISTANCE TO dB CONTOURS:

Lpk Noise Contour Value (dB)	Contour Distance (feet)
150	113
145	200
140	354
135	614
130	1,050
125	1,843
120	2,944
115	4,767
110	7,189
105	9,884
100	13,205
95	18,056
90	21,314
85	26,451
80	31,695
75	37,015
70	42,393

Contour distance calculations are most accurate within the decibel range of the direct attenuation calculations.

Except for sounds with highly distinctive tonal characteristics, noise from a particular source will not be identifiable when its incremental noise level contribution is significantly less than background noise levels.

Notes: Drop-off calculations include atmospheric absorption at 0.22 dB/100 meters, centered at the reference distance.

Except for sounds with highly distinctive tonal characteristics, noise from a particular source will not be identifiable when its incremental noise level contribution is significantly less than background noise levels.

Contour distance calculations are most accurate within the decibel range of the direct attenuation calculations.

APPENDIX G

SONIC BOOM ANALYSIS FOR FALCON LAUNCH VEHICLE

Presented to
Space Exploration Technologies
May 2, 2003

Performing Organization:
Flight Mechanics Department
Vehicle Systems Division

Coordinating Organization:
Space Launch Projects
Space Launch Support Division

Outline

- Introduction
- Study Approach
 - use of PCBoom3
- Results
 - Isopemps
 - Peak overpressure contours
- Reference comparison against Atlas IIAS and Titan IVB

SpaceX Task 4

- Contract: 1473-16213, Task 4
- Subject: Sonic Boom Analysis of Falcon Launch Vehicle
- Purpose: To provide Space X with overpressure and isopemp contours of Falcon for launch out of Vandenberg Air Force Base.
- Duration: April 14, 2003 - April 30, 2003
- SpaceX COTR: Gwynne Gurevich
- Aerospace PM: Jared Martin
- Aerospace Technical Task Leader: Rolf Bohman, Jeff Tooley
- Aerospace Contracts: Jerome Johnson

Statement of Work

Objective:

To perform a sonic boom analysis of the Falcon launch vehicle for launch out of Vandenberg Air Force Base. This analysis has been requested by the Air Force to examine potential environmental impacts associated with the overpressures produced by the launch of the Falcon from VAFB.

Deliverable:

Overpressure and isopemp contours plotted on a geographical information system. A brief description of the methodology used for the creation of the contours along with a description of the results will also be included.

Study Approach

- PCBoom3* used for sonic boom calculations
 - In response to request from VAFB Range Safety
- PCBoom3 has been used by Aerospace for sonic boom assessment of Titan, Atlas, and Minuteman III launches
- Inputs included in Falcon sonic boom analysis:
 - Trajectory data and vehicle description
 - Atmospheric data
 - Two atmospheric cases are run
 - 1971 Vandenberg standard atmosphere model is used with no winds
 - December atmosphere with mean (nominal) December winds
 - » Reference: Meteorology Group Range Commanders Council Document 362-83, *Range Reference Atmosphere 0-70 km*, April 1983.
 - Launch vehicle near-field signature
 - PCBoom3 has canned near field signatures based on the vehicle length, weight, shape, and plume description (vehicle plume drag was estimated as 25% of thrust)
 - For this analysis these canned signatures are used

*PCBoom3 Sonic Boom Prediction Model – Version 1.0e, Wyle Laboratories,
Wyle Research Report: WR 95-22E, Plotkin, K.J.; October 1998.

Discussion of Isopemp Plot

- Isopemps are the intersection of the ray cone (a cone perpendicular to the wave cone) and the ground
- The time labels denote the launch time when the ray cone associated with each isopemp was generated by the launch vehicle
- Isopemps are shown from 110 seconds to 148 seconds and are plotted out every two seconds
- Before 110 seconds no isopemps impact the ground
- After 148 seconds the associated overpressures are low, so the isopemps are not shown
- The largest overpressures will result where the isopemps begin overlapping
 - This occurs at the most uprange isopemps
 - This overlapping of isopemps is called focusing
 - On the figure these are the isopemps generated by the launch vehicle between 118 and 132 seconds

Isopemp Plot with No Winds 190° Launch Azimuth

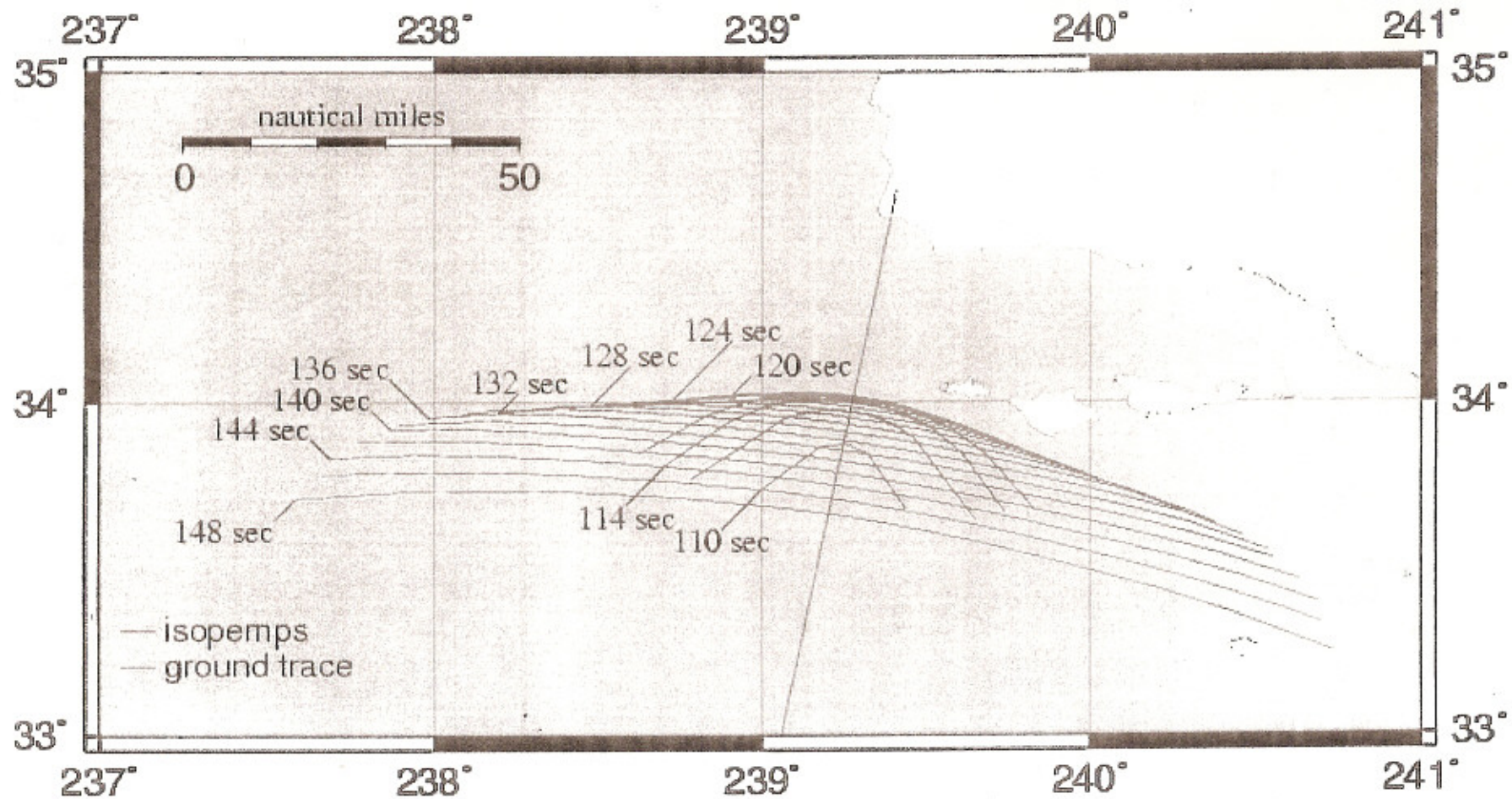

Peak Overpressure Contour Maps

- The following plots are based on a 1971 Vandenberg standard atmosphere model with no winds
- Atmospheric conditions are averaged across the year

Peak Overpressure Contours for Vandenberg Standard Atmosphere with No Winds - 190° Launch Azimuth

Largest peak overpressure of 2.66 psf

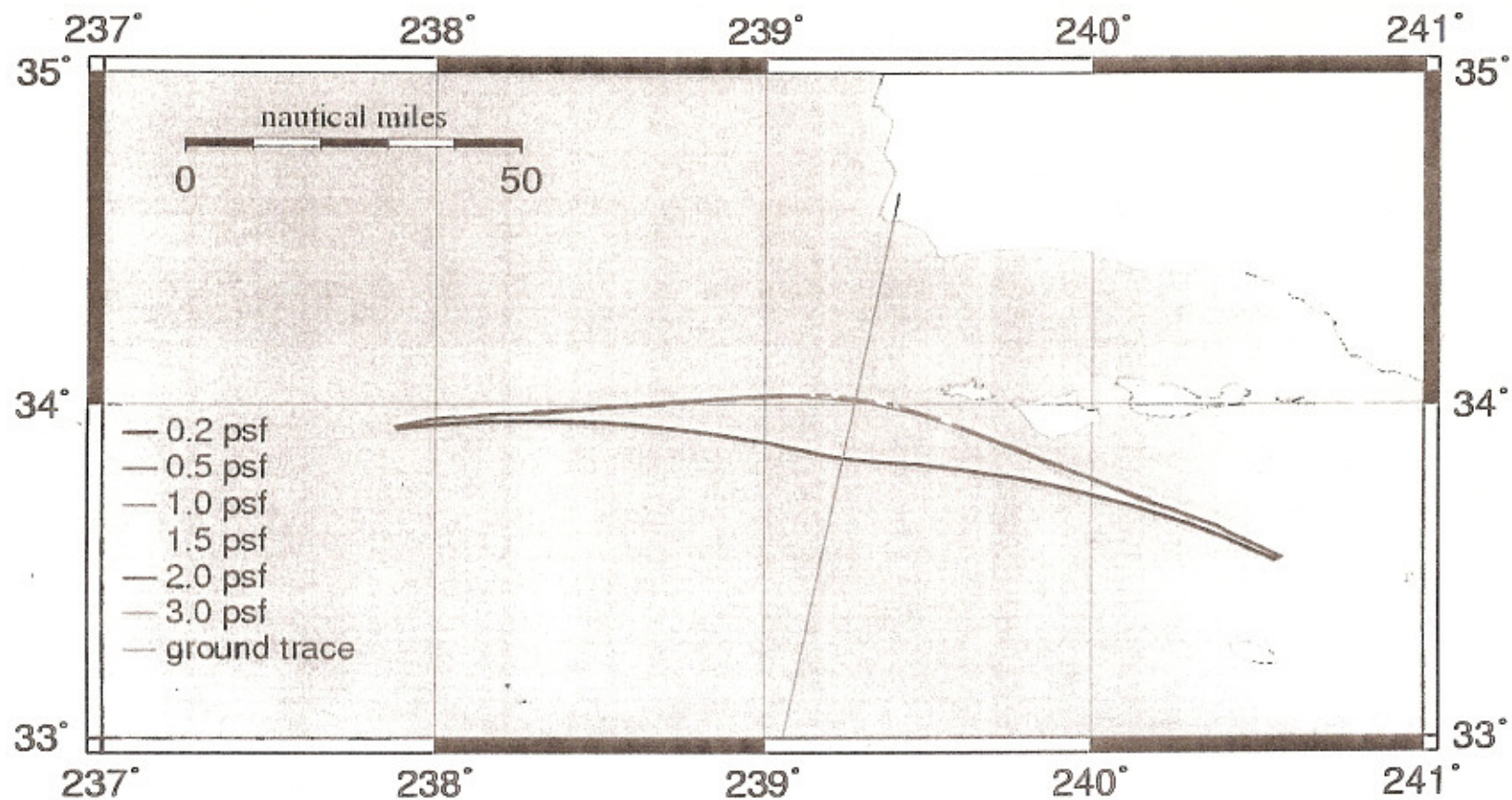

Peak Overpressure Contours for Vandenberg Standard Atmosphere with No Winds - 175° Launch Azimuth

Largest peak overpressure of 1.79 psf

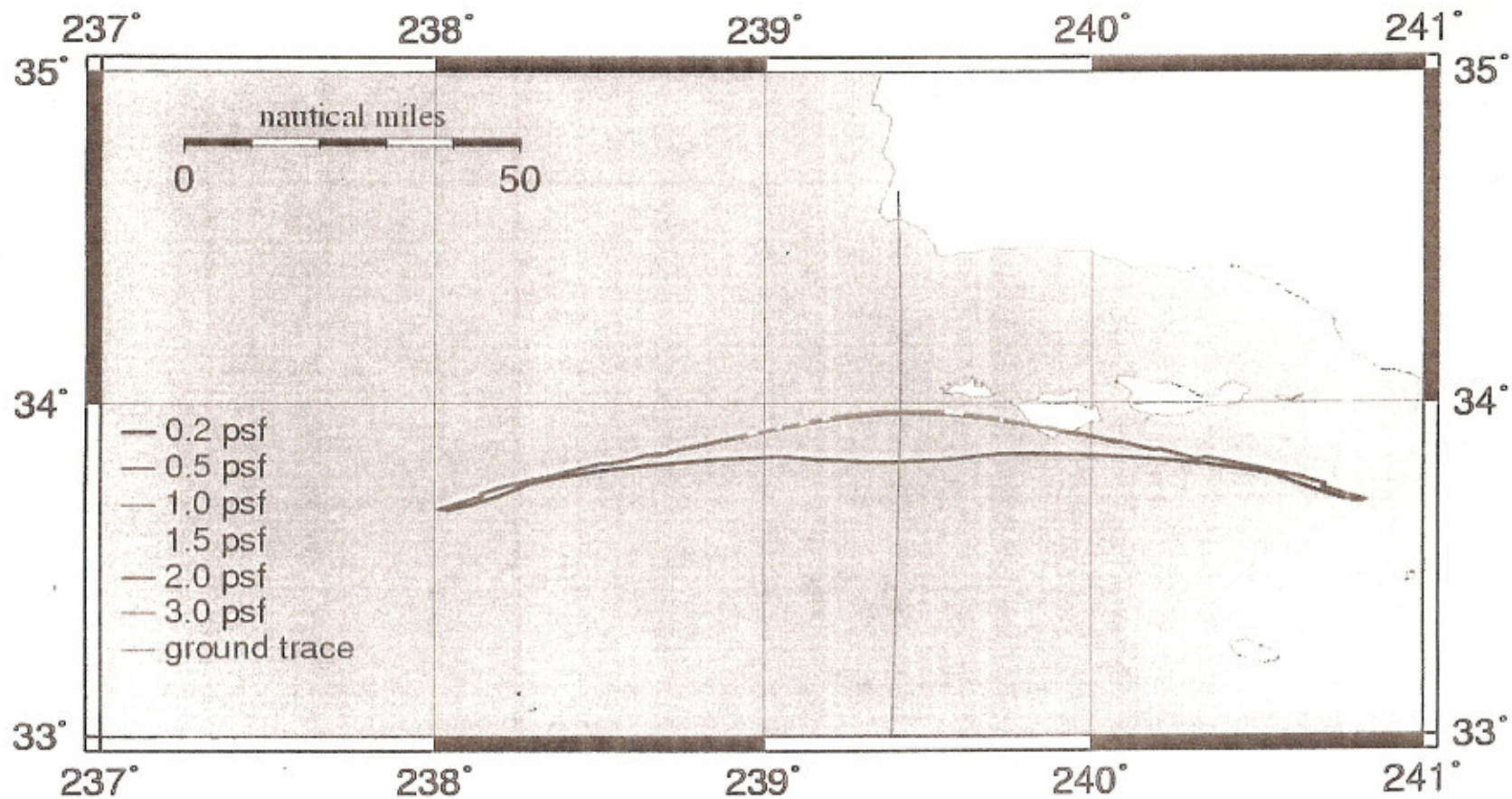

Peak Overpressure Contours for Vandenberg Standard Atmosphere with No Winds - 160° Launch Azimuth

Largest peak overpressure of 2.50 psf

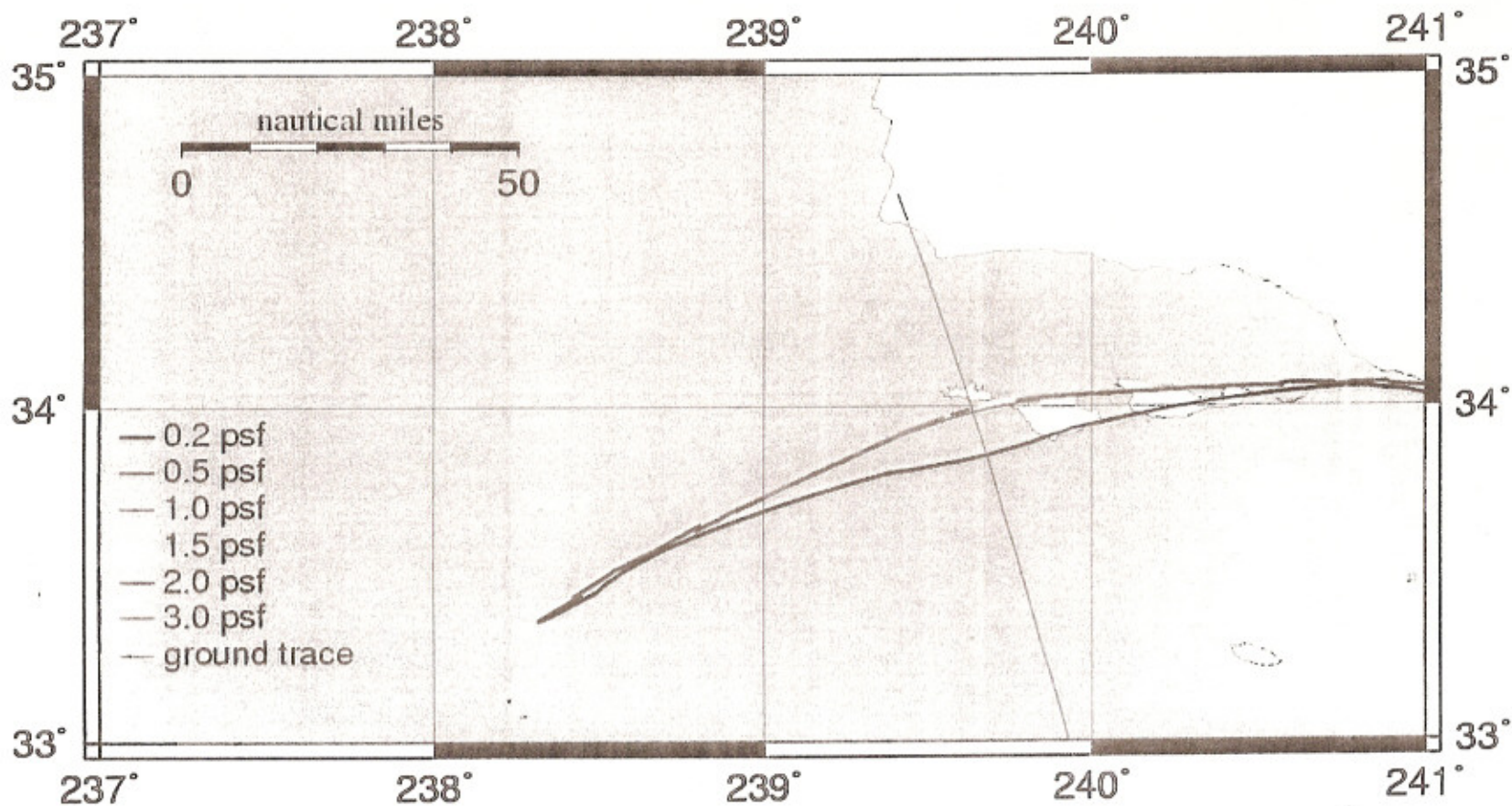

Discussion of Peak Overpressure Contours Year Average Atmospheric Conditions, No Winds

- Overpressure levels (on Islands) considered high for ≥ 2 psf
- Without winds, for 190° launch azimuth, Falcon overpressure does not impinge on Channel Islands
- Without winds, for 175° launch azimuth, there is an overpressure level of 1.0 psf on Santa Rosa
- Without winds, for 160° launch azimuth, the largest overpressure on the islands is 1.0-1.5 psf, on Santa Rosa

Peak Overpressure Contour Maps- December

- The following plots use the data for the average (mean) winds in December
 - Simulations accounting for the variability in the December wind conditions (± 3 sigma) have also been run

Peak Overpressure Contours for December Atmosphere and December Mean Winds - 190° Launch Azimuth

Largest peak overpressure of 7.05 psf

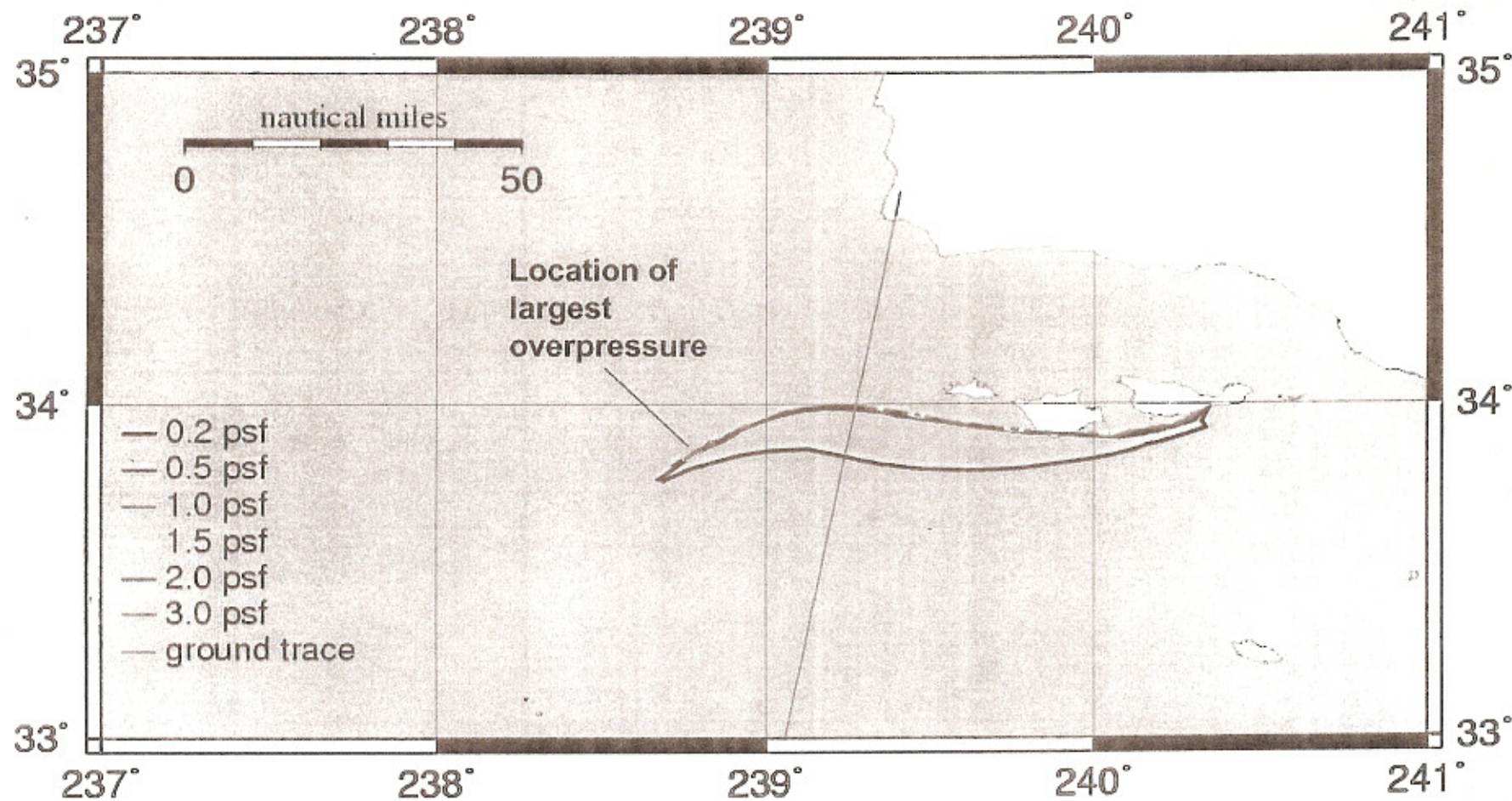

Peak Overpressure Contours for December Atmosphere and December +3 Sigma Winds - 190° Launch Azimuth

Largest peak overpressure of 3.95 psf

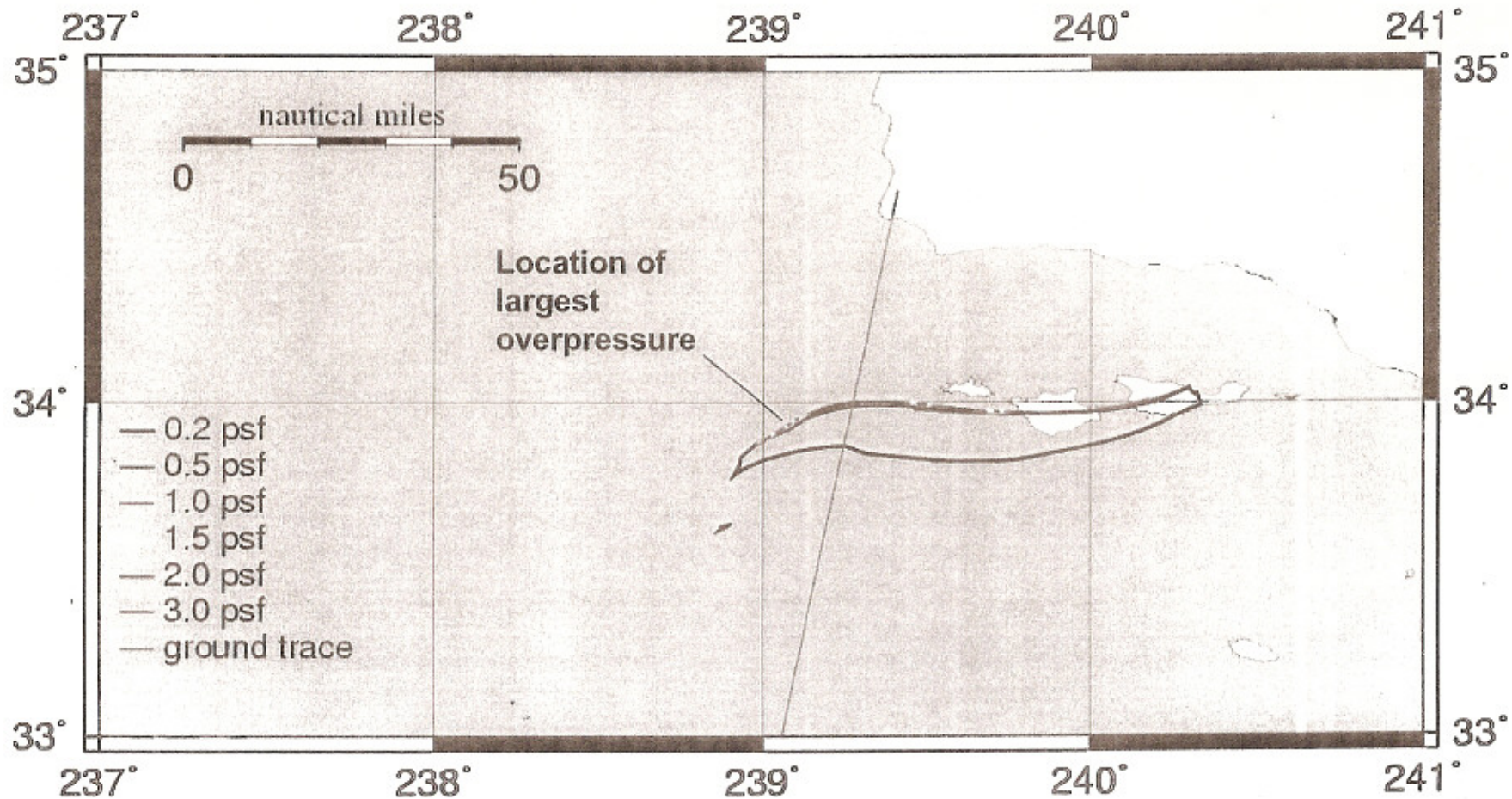

Peak Overpressure Contours for December Atmosphere and December -3 Sigma Winds - 190° Launch Azimuth

Largest peak overpressure of 1.87 psf

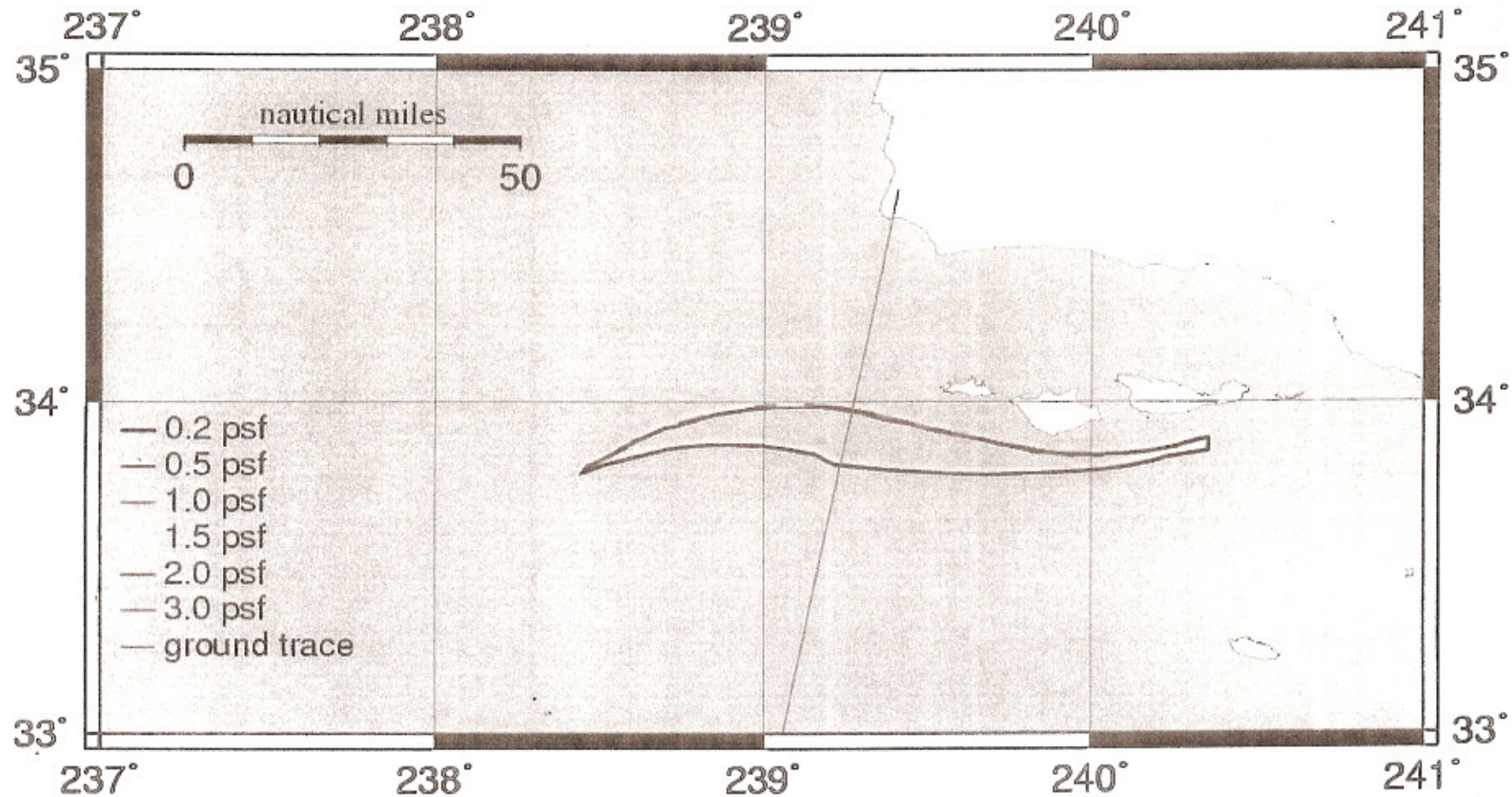

Peak Overpressure Contours for December Atmosphere and December Mean Winds - 175° Launch Azimuth

Largest peak overpressure of 2.02 psf

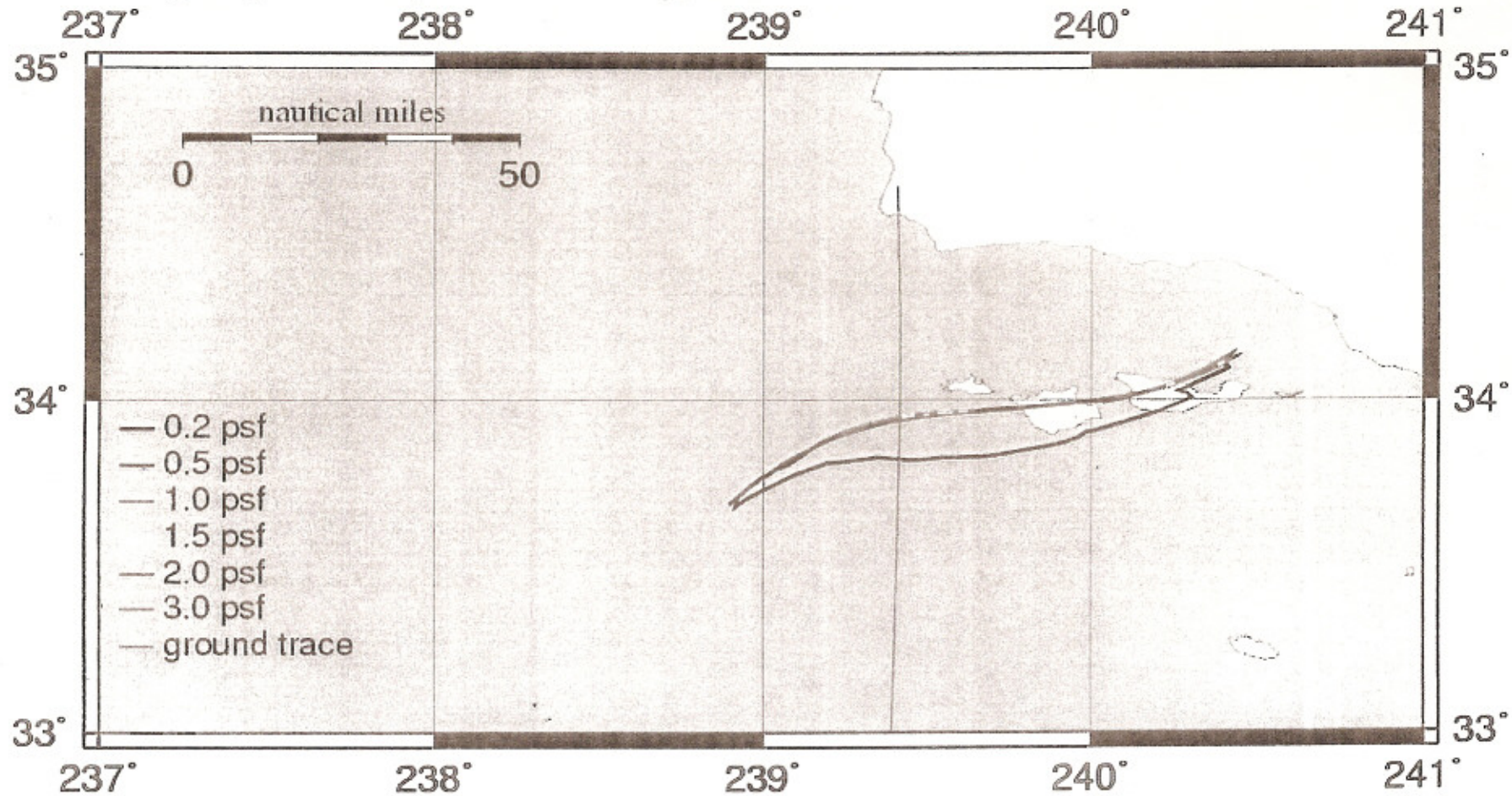

Peak Overpressure Contours for December Atmosphere and December +3 Sigma Winds - 175° Launch Azimuth

Largest peak overpressure of 10.14 psf

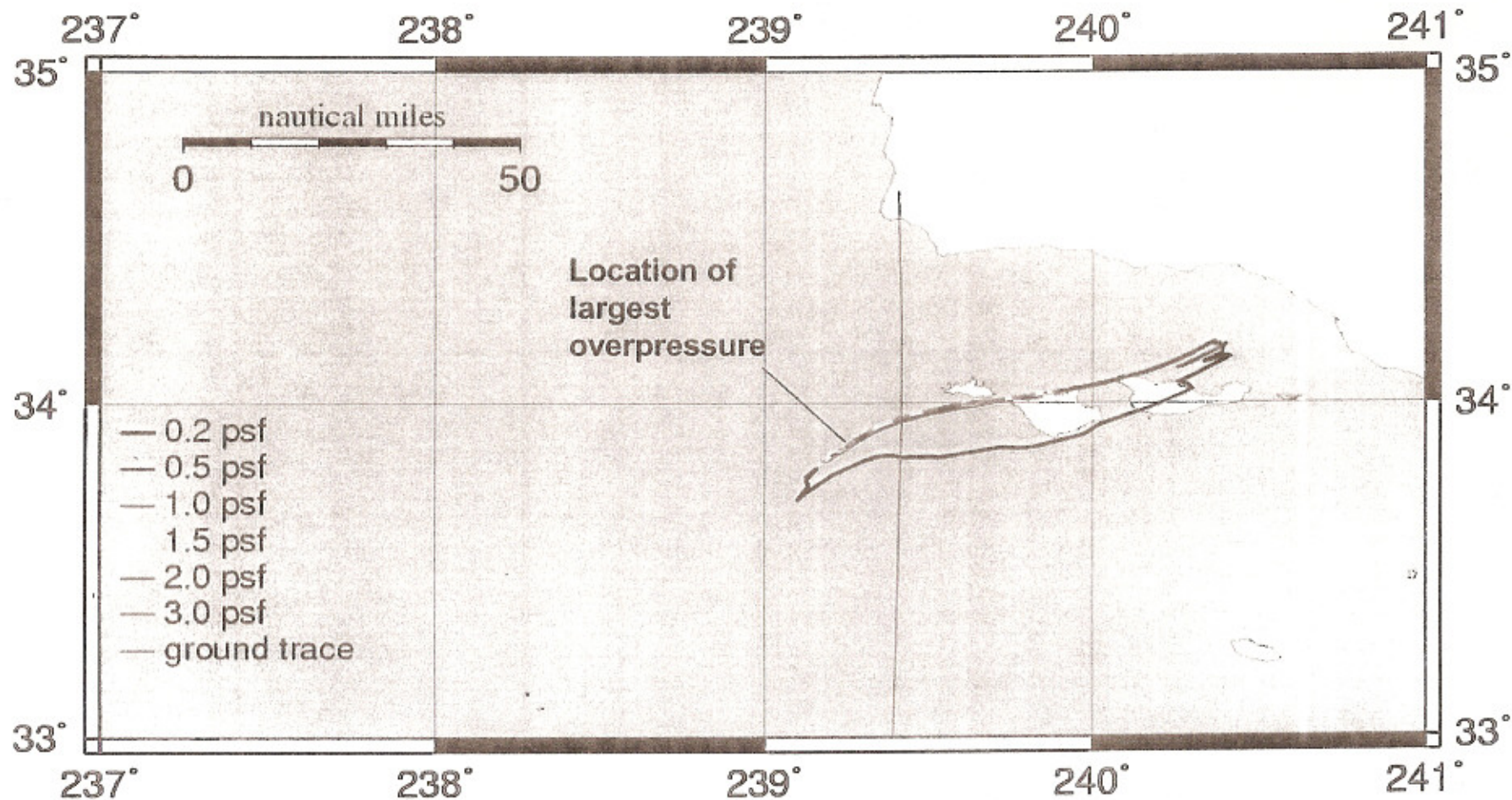

Peak Overpressure Contours for December Atmosphere and December -3 Sigma Winds - 175° Launch Azimuth

Largest peak overpressure of 8.92 psf

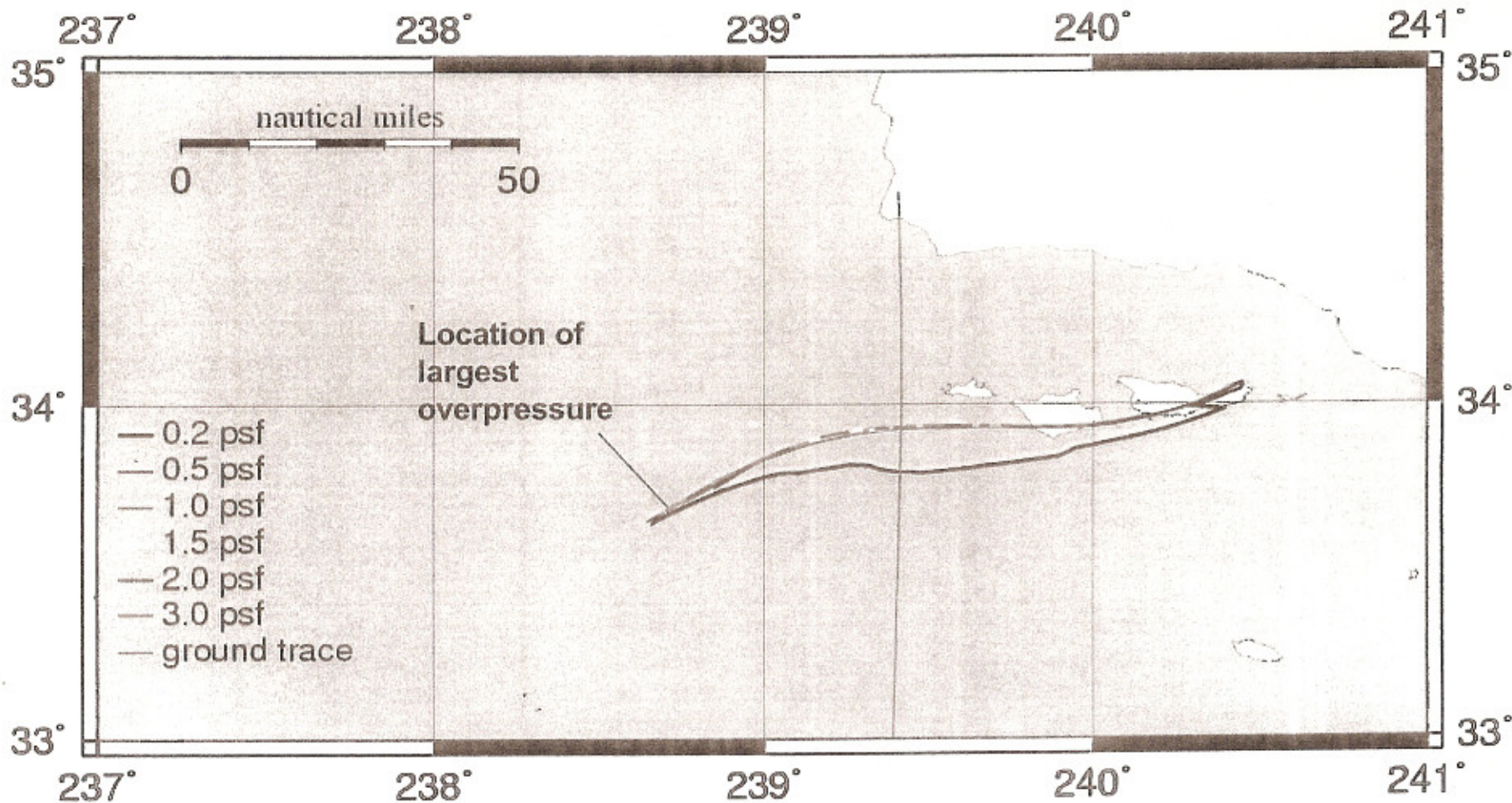

Peak Overpressure Contours for December Atmosphere and December Mean Winds - 160° Launch Azimuth

Largest peak overpressure of 2.65 psf

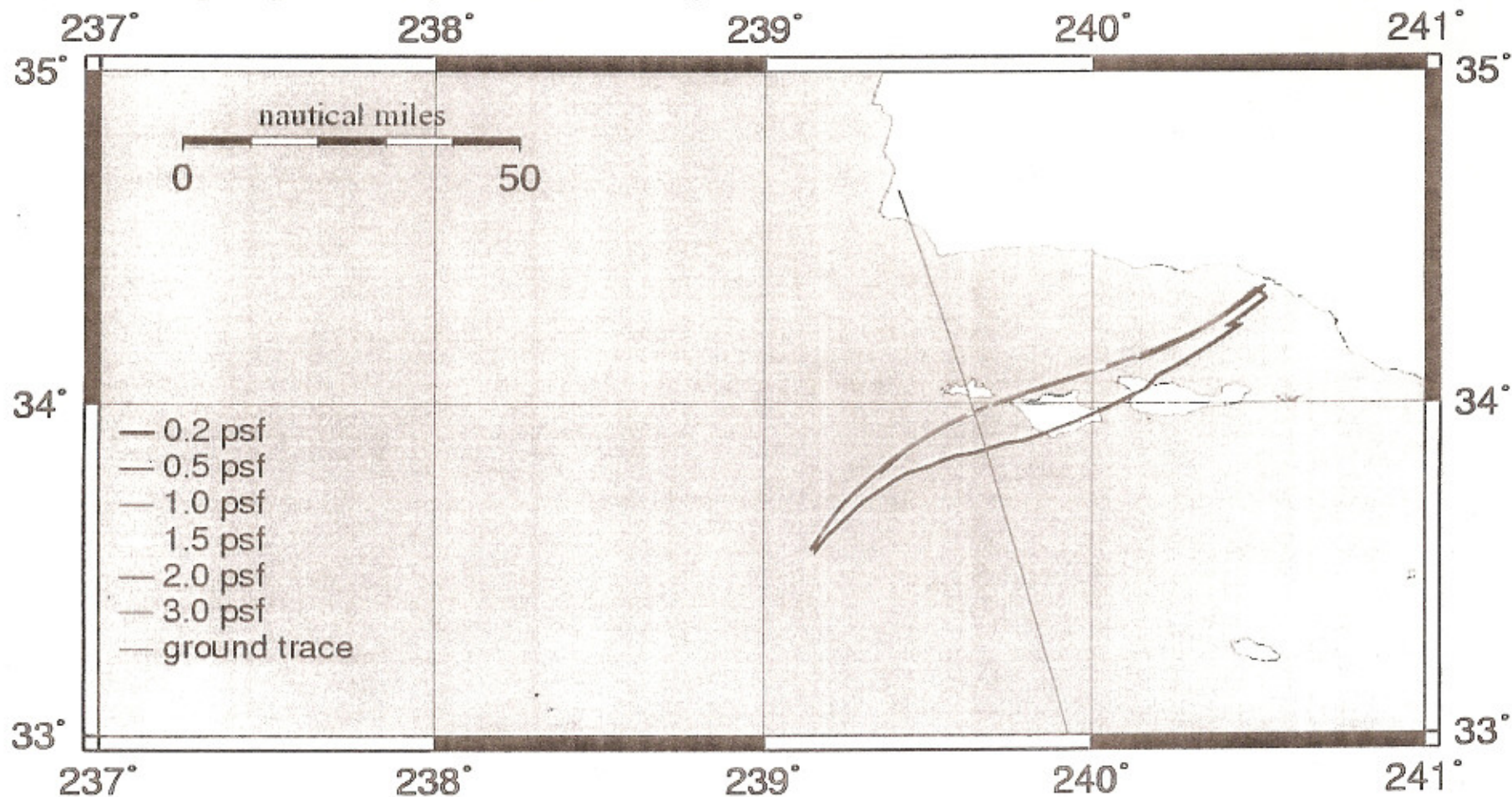

Peak Overpressure Contours for December Atmosphere and December +3 Sigma Winds - 160° Launch Azimuth

Largest peak overpressure of 2.48 psf

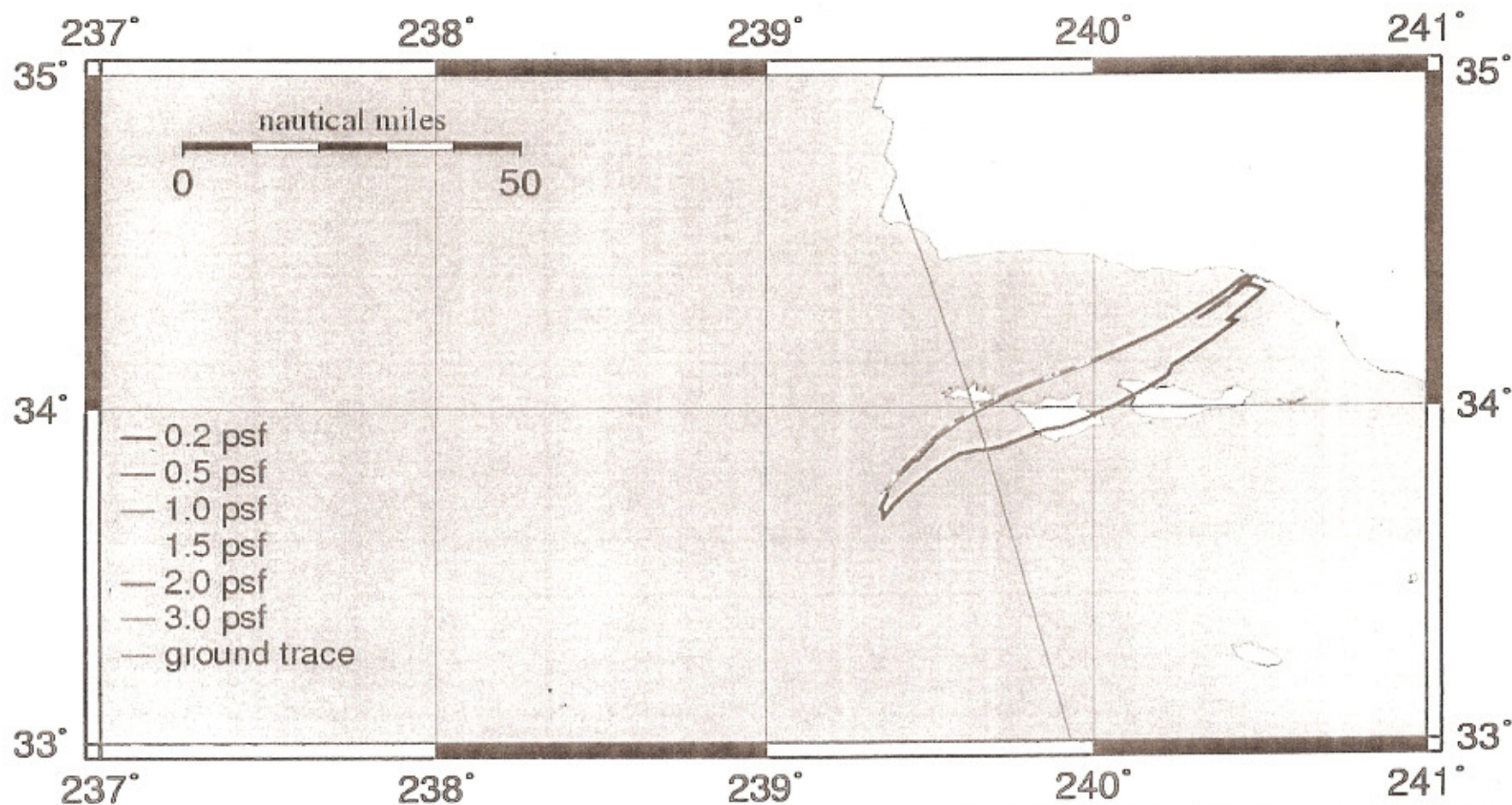

Peak Overpressure Contours for December Atmosphere and December -3 Sigma Winds - 160° Launch Azimuth

Largest peak overpressure of 1.67 psf

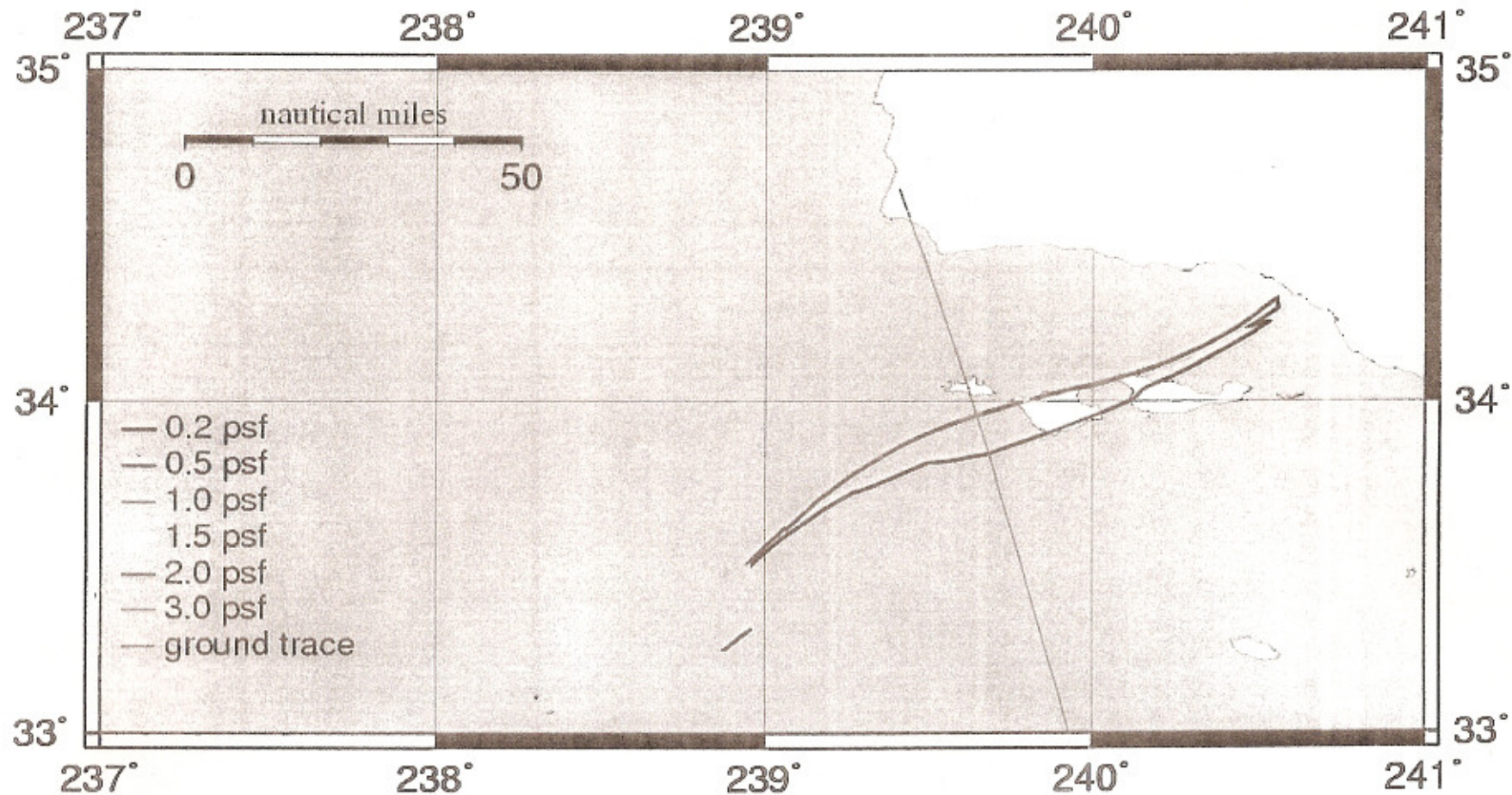



Discussion of Peak Overpressure Contours- December Winds

- Overpressure levels (on Islands) considered high for ≥ 2 psf
- For 190° launch azimuth, and +/- 3 sigma variability in December wind conditions
 - Largest overpressure on Islands is 1.0 psf on Santa Cruz and Santa Rosa
 - Largest peak overpressure is 7.05 psf, however this is for a very small area and occurs significantly far from Islands
- For 175° launch azimuth, and +/- 3 sigma variability in December wind conditions
 - Largest overpressure on Islands is 2.0 psf on Santa Rosa
 - Largest peak overpressure is 10.14 psf, however this is for a very small area and occurs significantly far from Islands
- For 160° launch azimuth, and +/- 3 sigma variability in December wind conditions
 - Largest overpressure on Islands is 2.3 psf on Santa Miguel
 - This is considered high overpressure level
 - Largest peak overpressure is 2.65 psf, however this is for a very small area and occurs away from Islands

Comparison Against Atlas IIAS and Titan IVB

Proprietary

			
Vehicle	Falcon	Atlas 2	Titan 4B
Company	SpaceX	Lockheed Martin	Lockheed Martin
GLOW	60,000 lbs	522,000 lbs	2,100,000 lbs
Length	70 ft.	155 ft.	204 ft.
Total 1 st Stage Engine Thrust	67,000 lbf	438,000 lbf	3,000,000 lbf

Proprietary

- Though Atlas IIAS and Titan IVB are an order of magnitude larger than Falcon, Aerospace has overpressure data for these for launches out of VAFB. They are therefore used for comparison.

Peak Overpressure Contours for Atlas IIAS

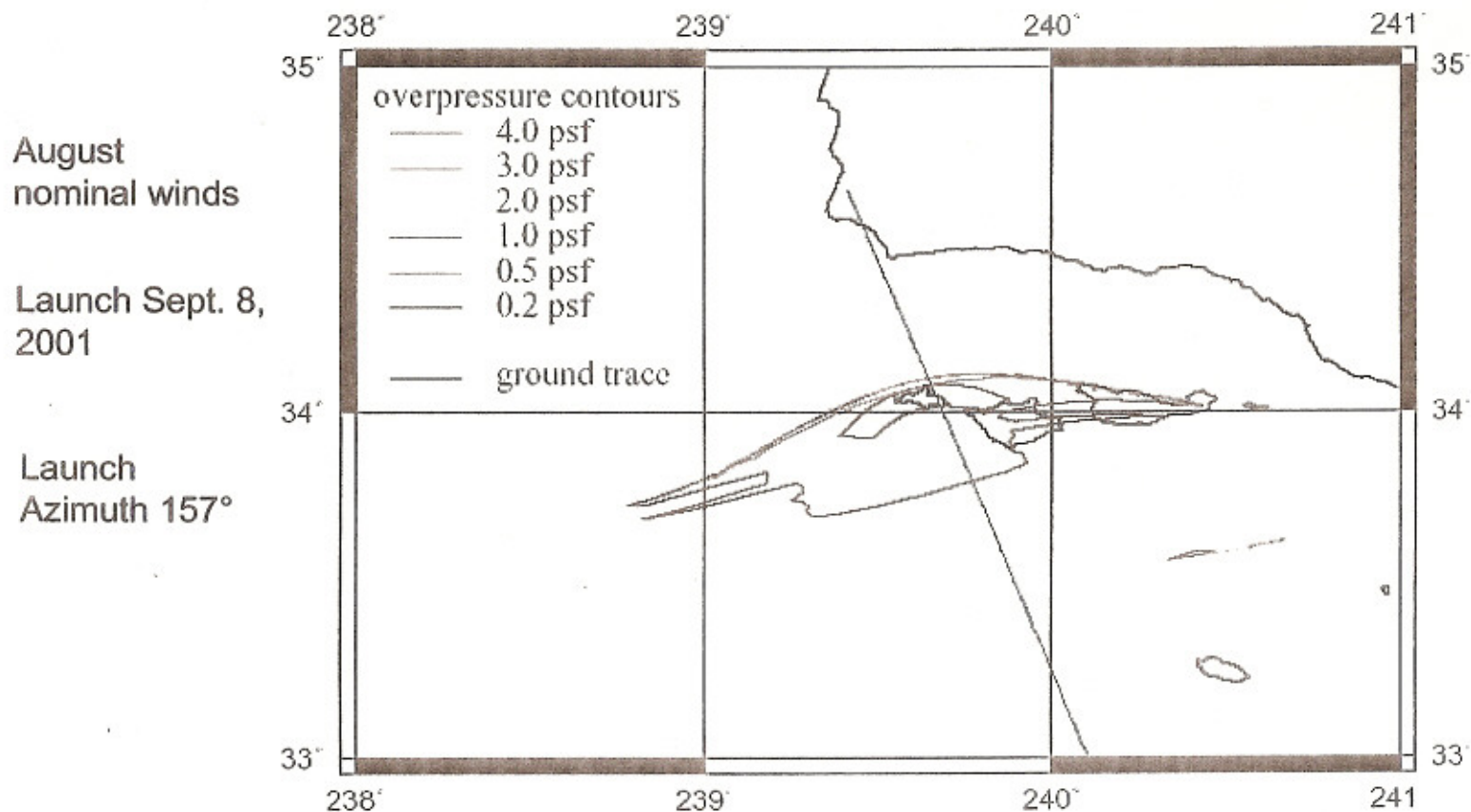

- Small region of 4.0 psf overpressure impacts northern tip of Santa Cruz Island

Peak Overpressure Contours for Titan IVB

May
-3 sigma
winds

Launch May
22, 1999

Launch
Azimuth 157°

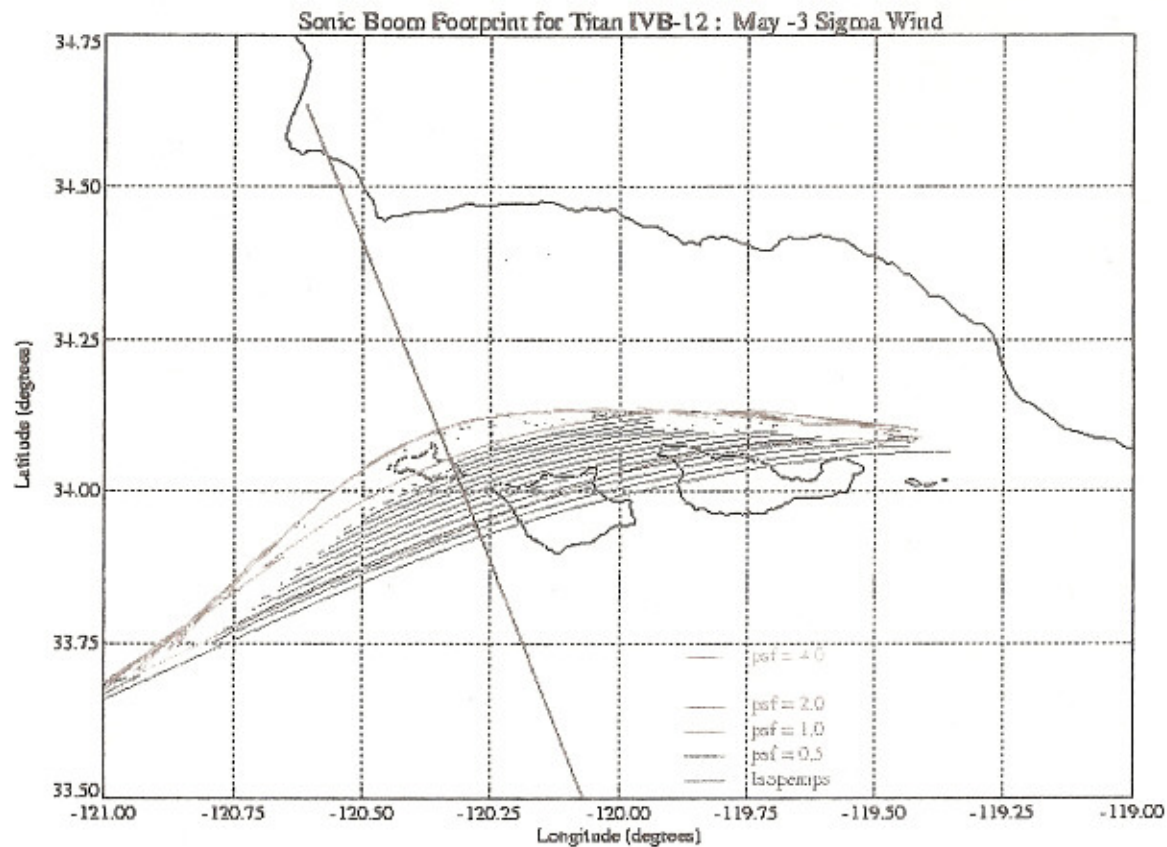

- Peak overpressure 4.0 psf
- 1.0 psf overpressure impacts San Miguel Island

A-Weighted Decibel Level Contour Maps- December

- The following plots use the data for the average (mean) winds in December
 - Simulations accounting for the variability in the December wind conditions (± 3 sigma) have not been run

A-Weighted Decibel Level Contours for December Atmosphere and December Mean Winds - 190° Launch Azimuth

Largest A-weighted decibel level of 99.5 dBA

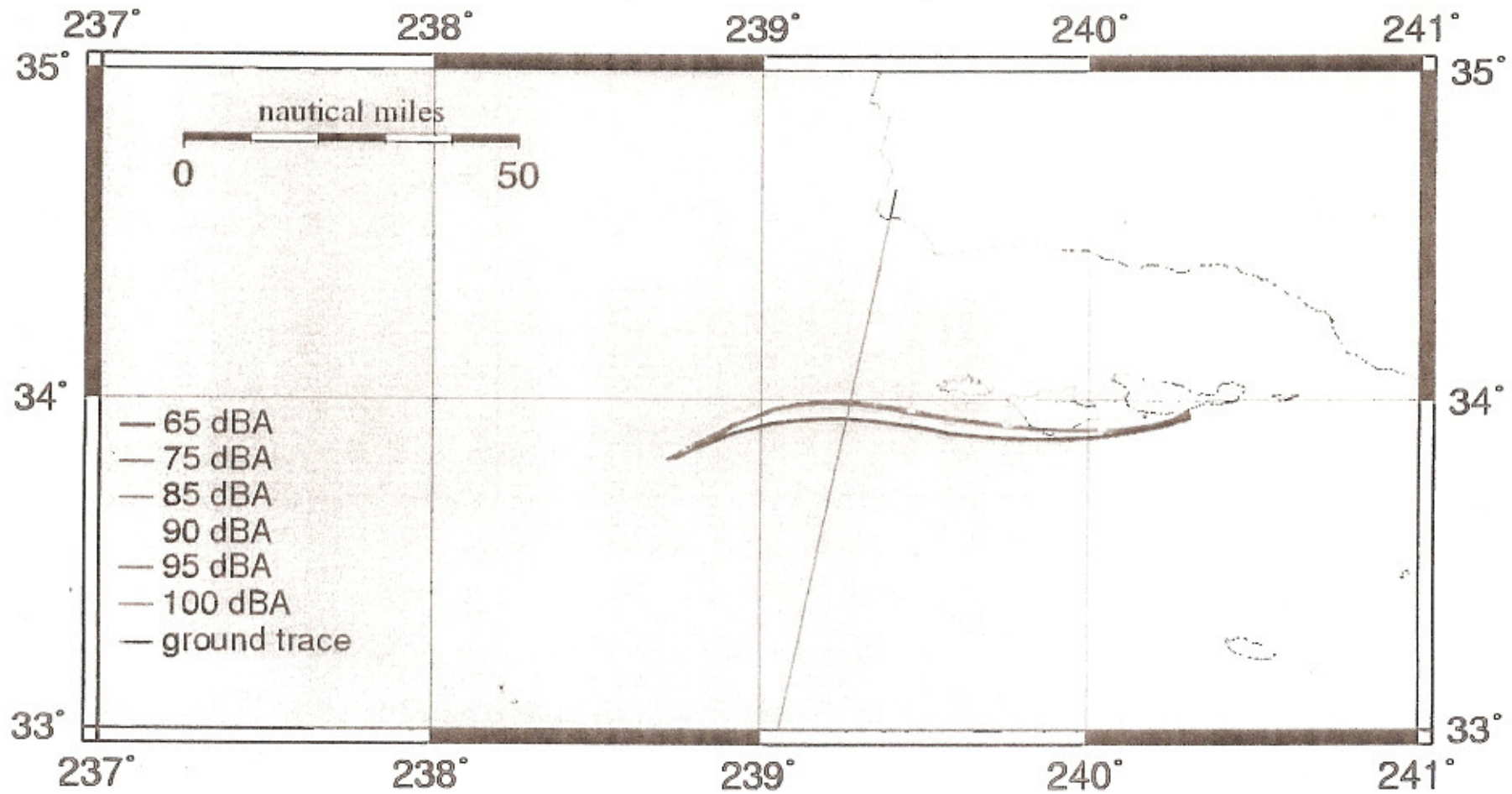

A-Weighted Decibel Level Contours for December Atmosphere and December +3 Sigma Winds - 190° Launch Azimuth

Largest A-weighted decibel level of 95.0 dBA

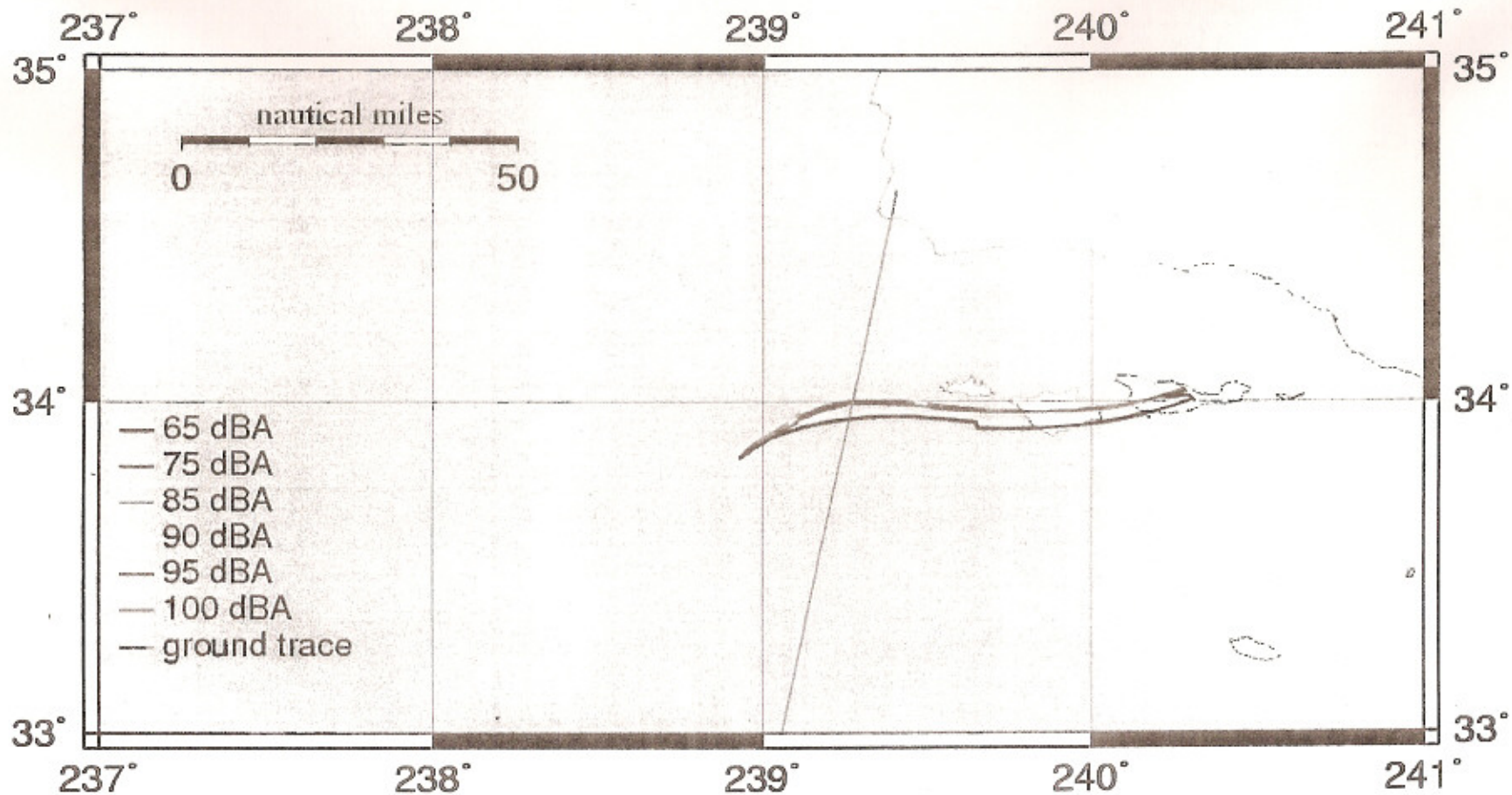

A-Weighted Decibel Level Contours for December Atmosphere and December -3 Sigma Winds - 190° Launch Azimuth

Largest A-weighted decibel level of 88.0 dBA

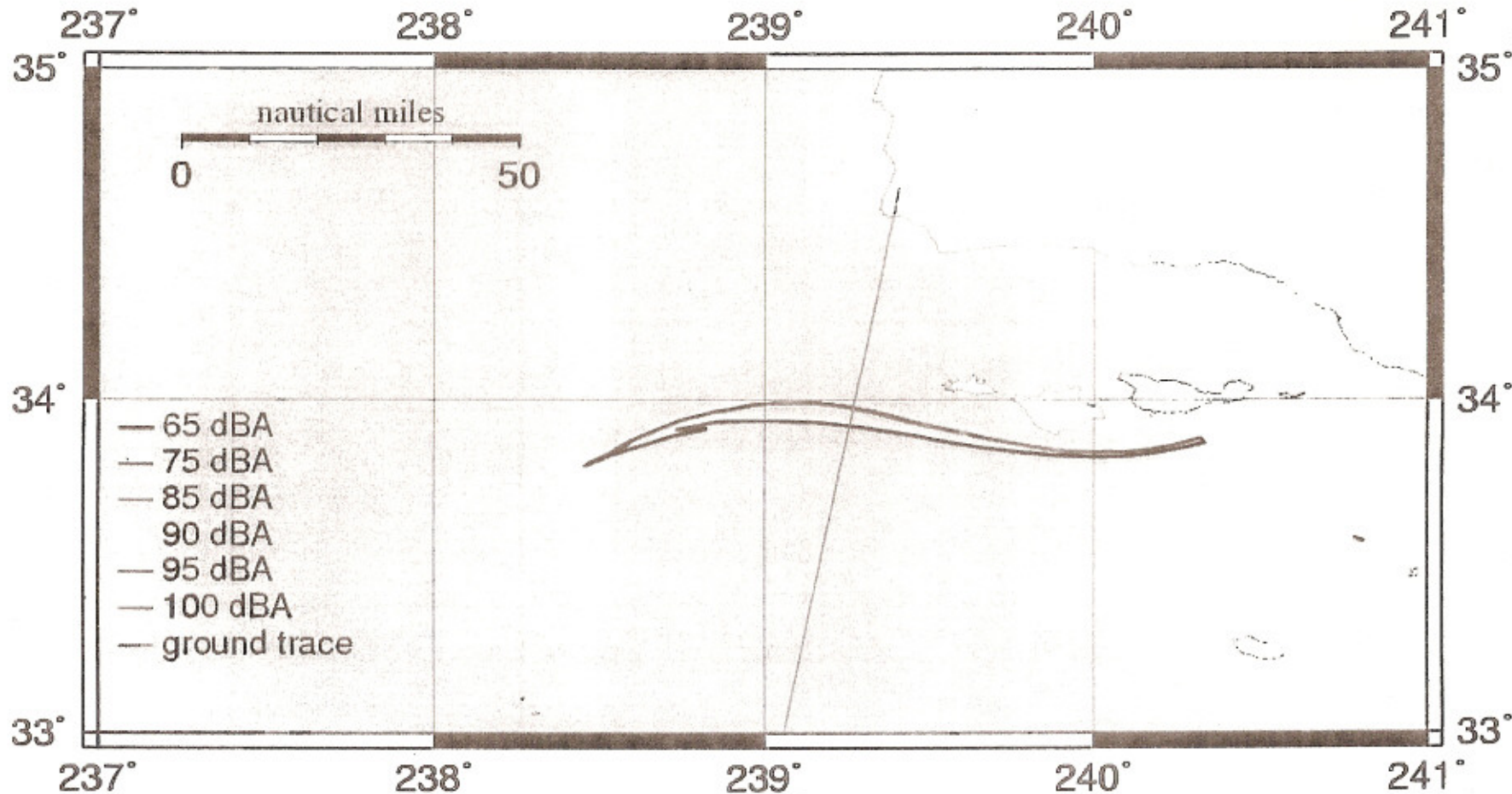

A-Weighted Decibel Level Contours for December Atmosphere and December Mean Winds - 175° Launch Azimuth

Largest A-weighted decibel level of 91.1 dBA

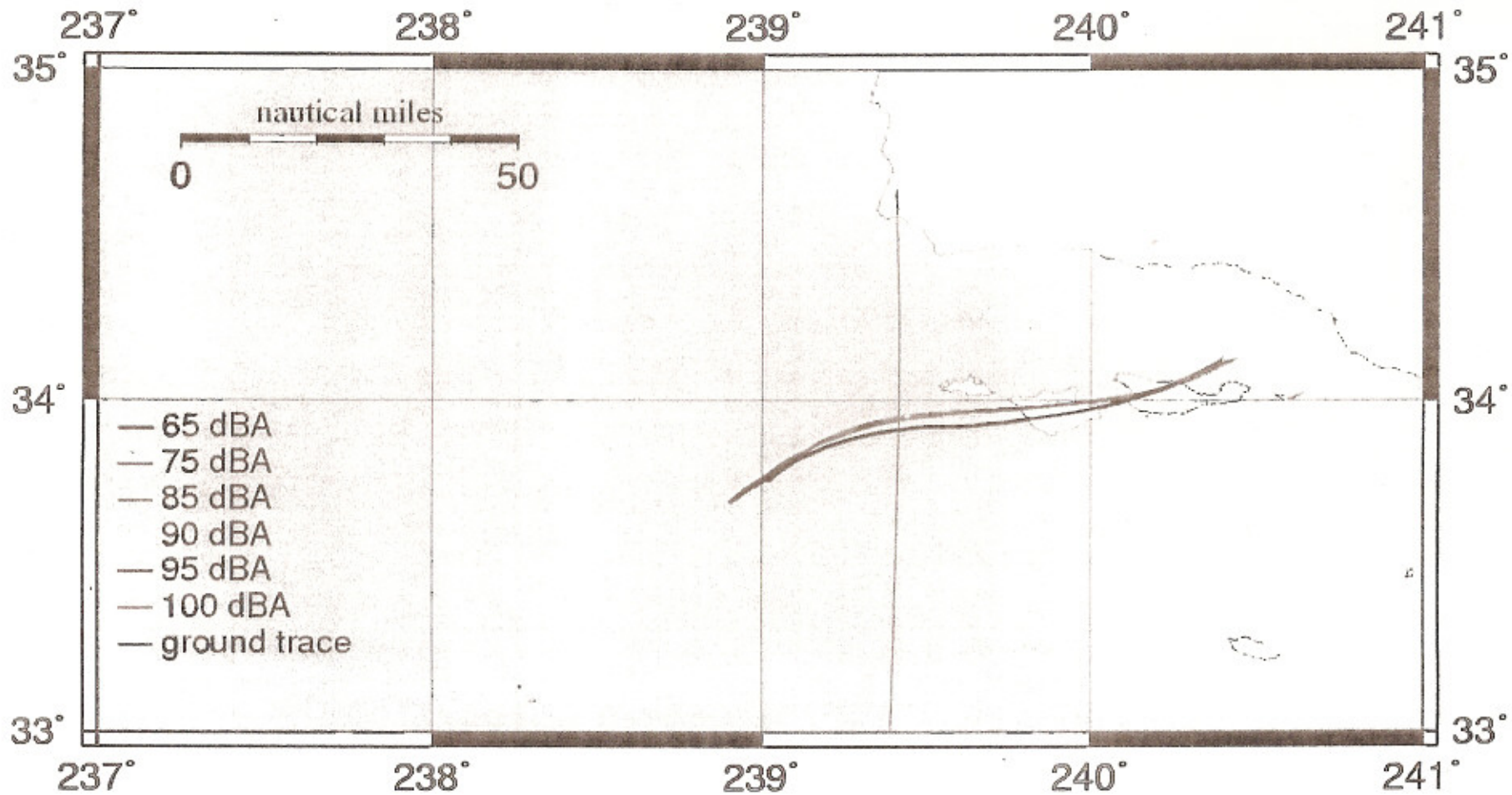

A-Weighted Decibel Level Contours for December Atmosphere and December +3 Sigma Winds - 175° Launch Azimuth

Largest A-weighted decibel level of 103.8 dBA

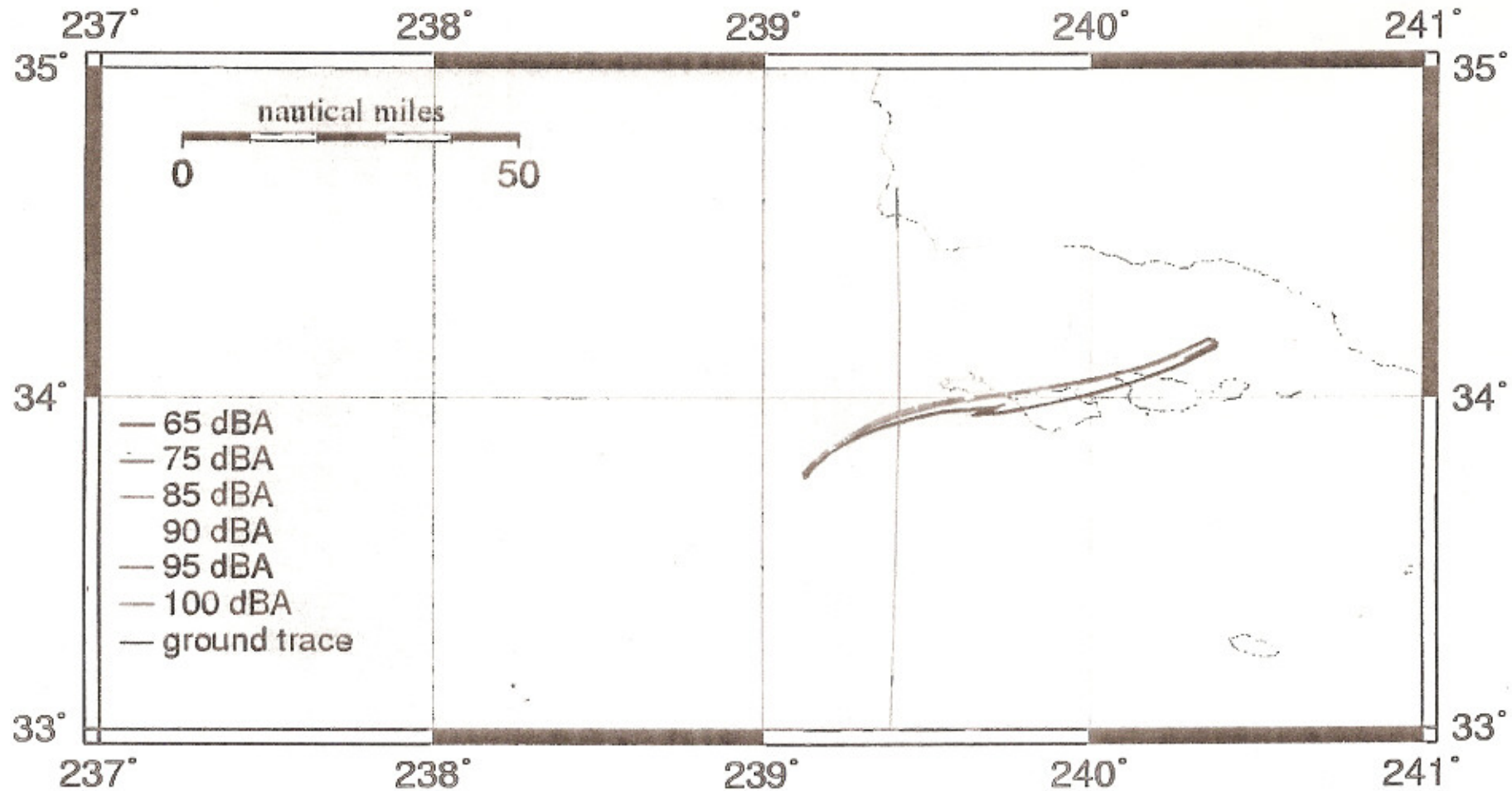

A-Weighted Decibel Level Contours for December Atmosphere and December -3 Sigma Winds - 175° Launch Azimuth

Largest A-weighted decibel level of 101.5 dBA

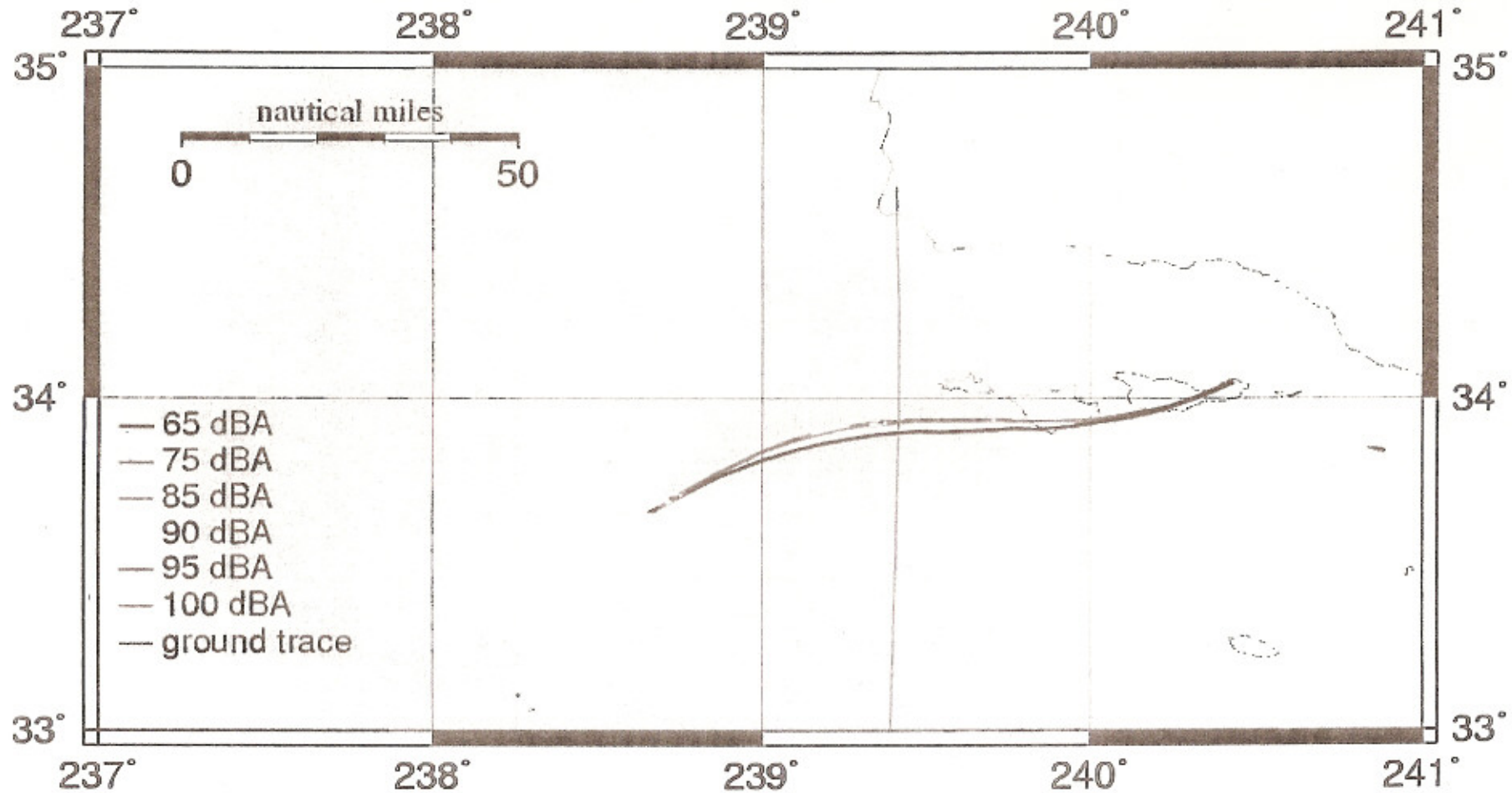

A-Weighted Decibel Level Contours for December Atmosphere and December Mean Winds - 160° Launch Azimuth

Largest A-weighted decibel level of 95.9 dBA

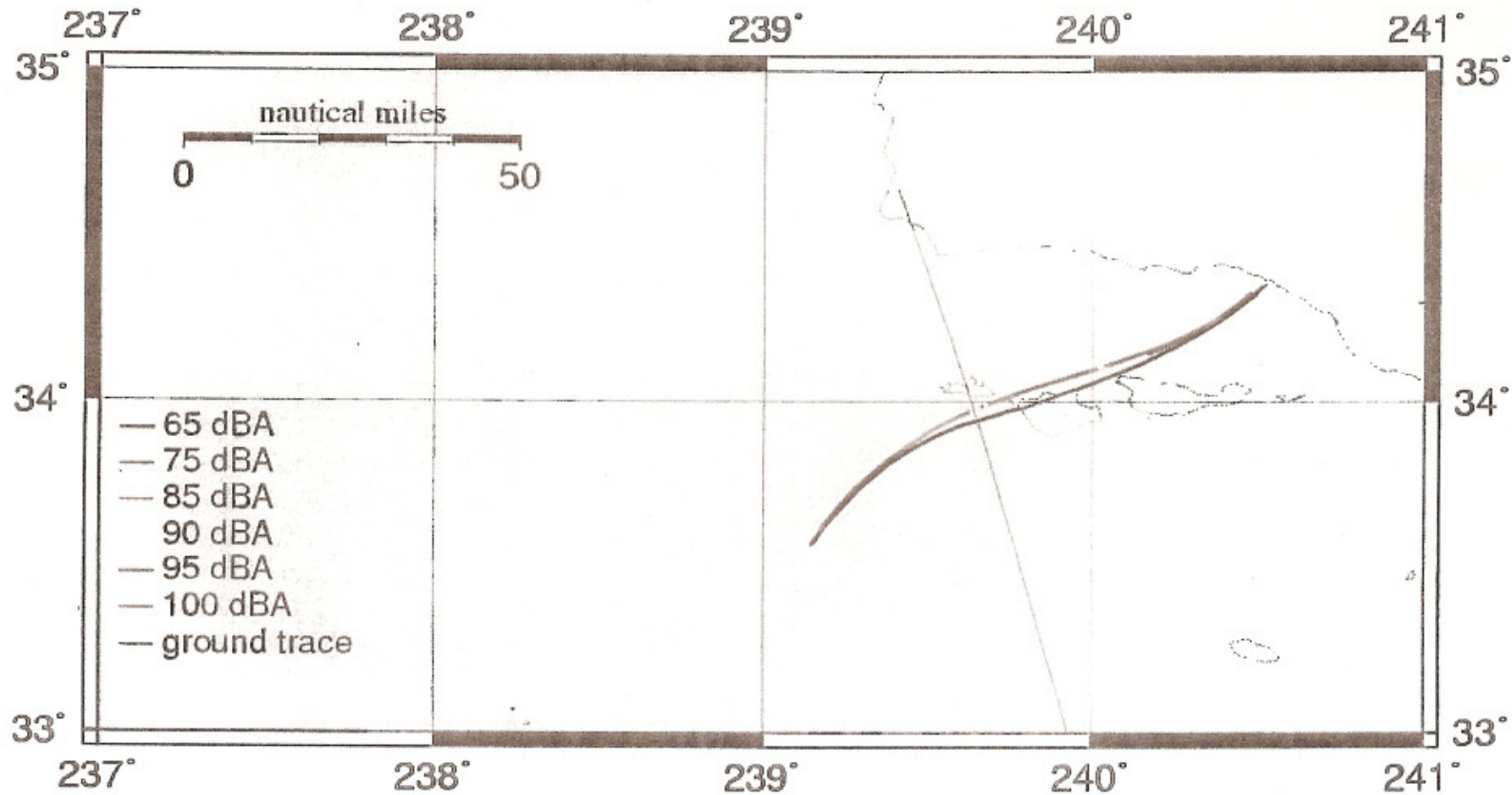

A-Weighted Decibel Level Contours for December Atmosphere and December +3 Sigma Winds - 160° Launch Azimuth

Largest A-weighted decibel level of 95.1 dBA

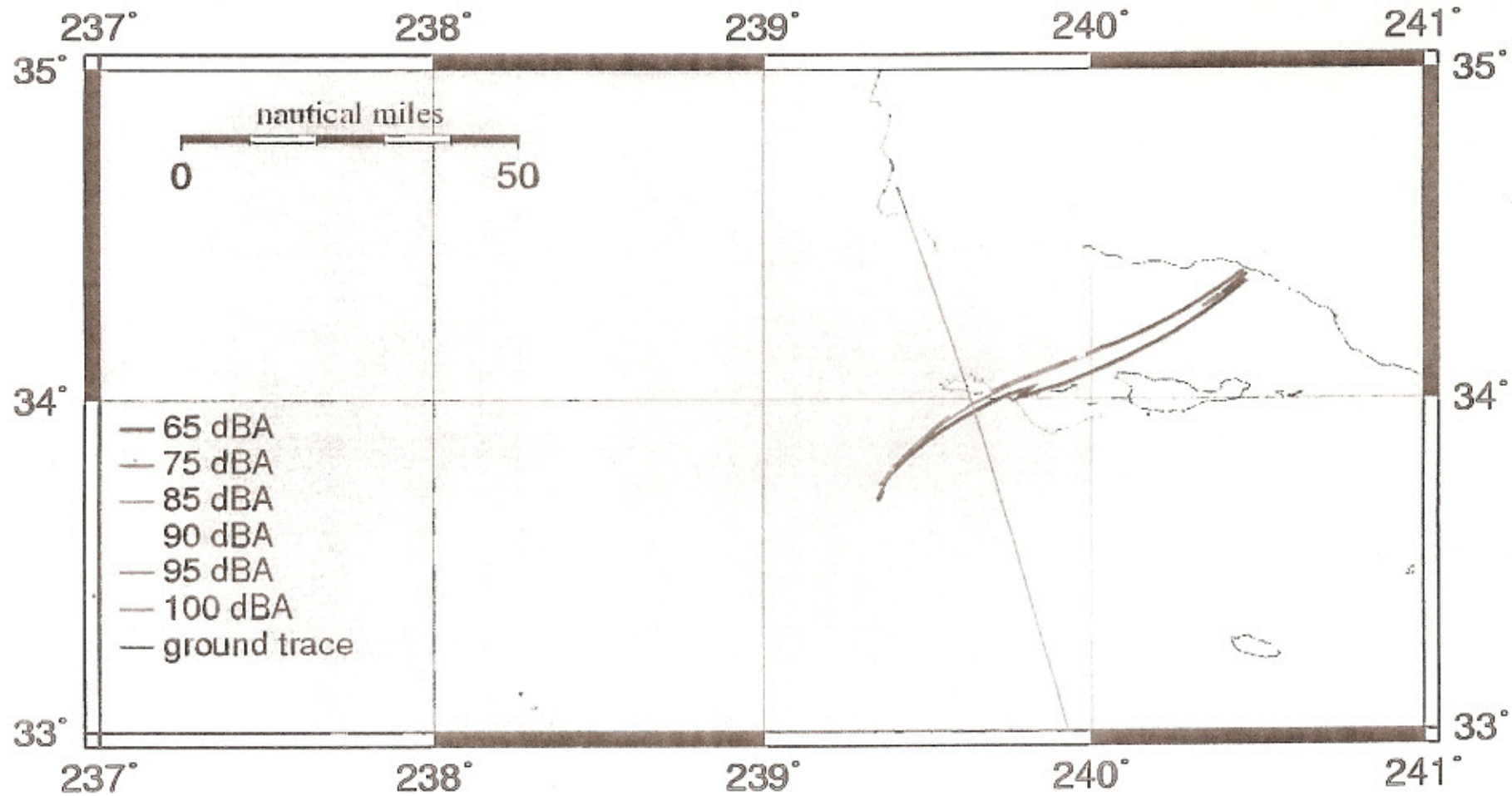

A-Weighted Decibel Level Contours for December Atmosphere and December -3 Sigma Winds - 160° Launch Azimuth

Largest A-weighted decibel level of 88.2 dBA

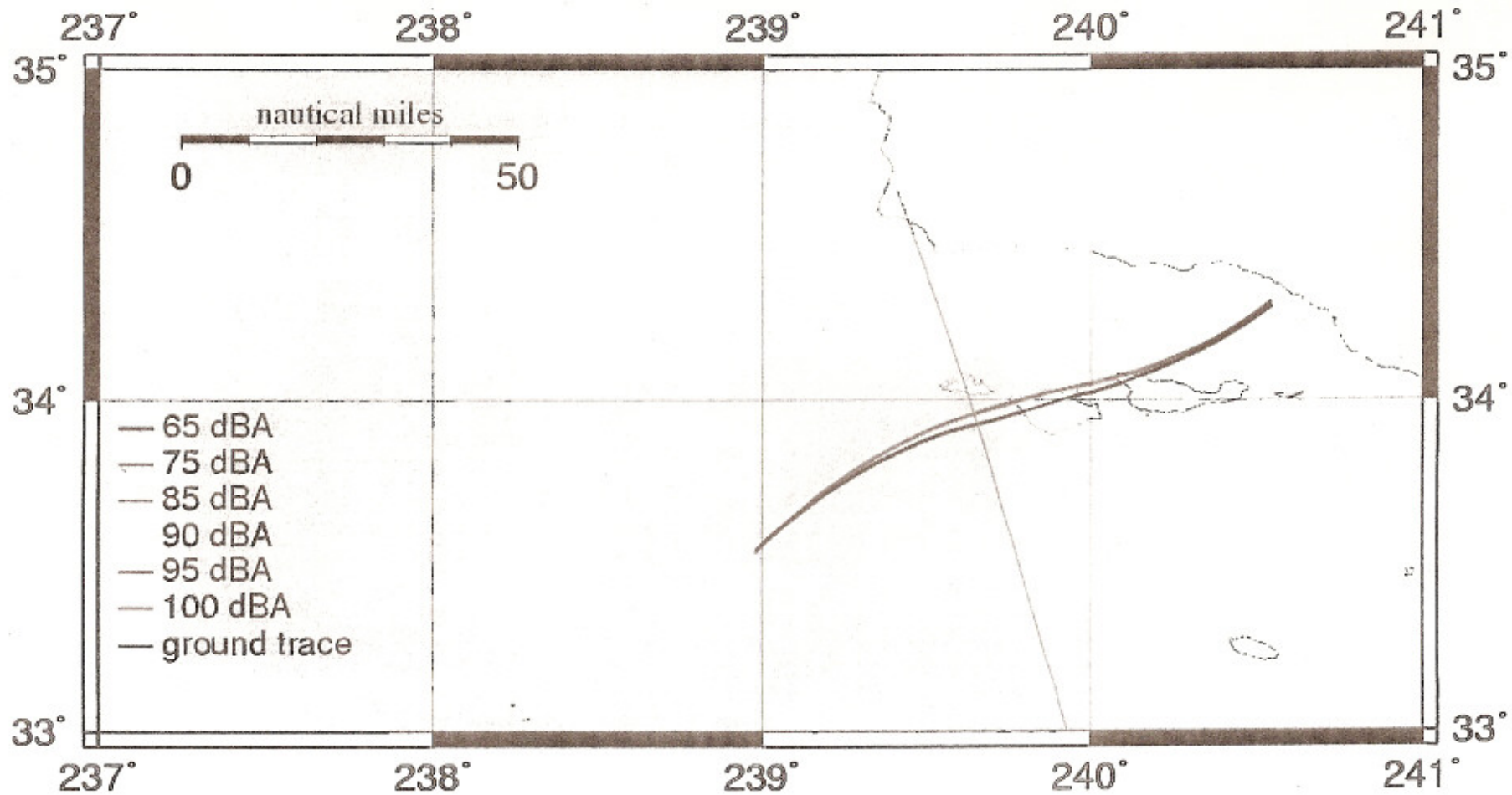

APPENDIX H

FALCON TENTATIVE FUEL AND ORDNANCE LOADS

Fuel/Ordnance	Quantity / Comments
RP-1 (Nominal)	
Quantity of RP-1 on 2nd Stage at Lift-off	30771 lbs
Quantity of RP-1 left on the 2nd Stage upon re-entry.	~ 100 lbs
Hypergols (Nominal)	
Quantity of Hypergol on 2nd Stage at Lift-off	MMH: 247.9 Lbs. NTO: 440.4 Lbs. Total Hypergols: 688.3 Lbs.
Quantity of Hypergol left on the 2nd Stage upon re-entry.	Undetermined at this time. Working on a Hypergol Burn/Dump scenario
Quantity of Hypergol on Dragon at Lift-off	MMH: 991.6 Lbs. NTO: 1,761.4 Lbs. Total Hypergols: 2,753.0 Lbs. A full propellant load would be 2700 lbs (1681 lbs of nitrogen tetroxide and 1019 lbs of monomethylhydrazine)
Quantity of Hypergol left on the Dragon upon re-entry.	Undetermined at this time. Working on a Hypergol Burn/Dump scenario
Ordnance (Nominal)	
Ordnance on Dragon at Lift-off	There are more than 60 pyros on Dragon. There is no ordnance currently in the Dragon propulsion system, although still deciding upon residual propellant off-loading (which could include pyro-valves).
Un-exploded Ordnance on Dragon upon re-entry	Unclear at this time
Ordnance on 2nd Stage at Lift-off	Unclear at this time
Un-exploded Ordnance on 2nd Stage upon re-entry	Unclear at this time
Dragon Dimensions	
Actual overall dimensions of Dragon	175.1 Inches high by 147.6 Inches wide (see enclosure)
Mission Specific	
COTS Demo # 1 and 2	
2nd Stage at Lift-off	All RP-1 and Hypergol Loads Nominal
Dragon At Lift-off	All Hypergolic Loads Nominal
2nd Stage at re-entry	~ 100 lbs
Dragon at Re-entry	TBD
GD Mission	
2nd Stage at Lift-off	All RP-1 and Hypergol Loads Nominal
P/L At Lift-off	No Hypergolics on the Payload for this flight
2nd Stage at re-entry	~ 100 lbs
P/L at Re-entry	No Hypergolics on the Payload for this flight
Cassiope Mission	
2nd Stage at Lift-off	All RP-1 and Hypergol Loads Nominal
P/L At Lift-off	No Hypergolics on the Payload for this flight
2nd Stage at re-entry	~ 100 lbs
P/L at Re-entry	No Hypergolics on the Payload for this flight
Source: SpaceX April 2007	

APPENDIX I

HYPERGOLIC FUELS: Toxic Chemical Dispersion Modeling

Appendix B below documents the mean hazard distance predictions for release of the routine payload's maximum liquid propellant loads, which consist of 1000 kg (2200 lb) of hydrazine, 1000 kg (2200 lb) of MMH, and 1200 kg (2640 lb) of NTO. The U. S. Air Force Toxic Chemical Dispersion Model (AFTOX) Version 4.0 (Kunkel, 1991) was used to predict the mean hazard distances resulting from the spillage of each of the three liquid propellants. AFTOX is a simple Gaussian puff/plume dispersion model that assumes a uniform windfield. AFTOX was used to predict mean distances to selected downwind concentrations of each toxic vapor. The selected concentrations used for this analysis were the Short-Term Emergency Guidance Levels (SPEGLs) for hydrazine (0.12 ppm 1-hour average), MMH (0.26 ppm 1-hour average), and nitrogen dioxide (1.0 ppm 1-hour average). AFTOX runs were conducted for daytime and nighttime conditions at two different wind speeds (2 and 10 m/s (7 and 32 feet per second)). These meteorological conditions were selected to illustrate possible hazard distances. Other meteorological conditions would produce different hazard distances but would not change the conclusion that the concentrations fall below hazardous levels within a relatively short distance of the release. Appendix B provides some AFTOX output relevant to this FEA. Spillage of the entire payload propellant load, while unlikely, could occur during payload processing, payload transportation, payload mating to the launch vehicle, or during the actual launch operation. A launch accident could result in payload ground impact resulting in propellant tank rupture and spillage. The cases modeled by AFTOX are worst case since they assume that the spills are unconfined and evaporate to completion without dilution or other mitigating action. The following sections summarize the results presented in Appendix B and document the areas and distances that would temporarily have hazardous levels of the propellants in the event of a spill. These results indicate that the chemicals are diluted to non-hazardous levels in reasonably short distances.

The mean hazard distances predicted by AFTOX for the CCAFS and KSC area are displayed in Table 4.1-5. An unconfined spill of 1000 kg (2200 lb) of hydrazine would produce a spill area of 107 m² (1156 ft²) and a mean hazard distance of up to 1493 m (4897 ft). An unconfined spill of 1000 kg (2200 lb) of MMH would produce a spill area of 114 m² (1231 ft²) and a mean hazard distance of up to 1452 m (4763 ft). An unconfined spill of 1200 kg (2640 lb) of NTO would produce a spill area of 80 m² (864 ft²) and a mean hazard distance of up to 5680 m (18,630 ft) for NTO. Note: AFTOX predicts that NTO liquid spills would be gas releases at 32°C (90°F) ambient temperature. For modeling purposes, the gas release was assumed to have a duration of five minutes. In summary, all mean hazard distances for toxic air releases from payload accidents at CCAFS and KSC would be less than 5.7 km (3.4 mi) for the

meteorological conditions considered. This would be the maximum distance downwind that would require evacuation and control by range safety authorities.

Mean Hazard Distances to SPEGL (1-Hr Average) Exposure Limits as Predicted by AFTOX for Payload Maximum Liquid Propellant Spills at CCAFS and KSC

Chemical (SPEGL)	Spill Quantity	Wind Speed	Day (32C/90F)	Night (5C/41F)
Hydrazine (0.12 ppm)	1000kg (2200 lbs)	2 m/s (6.6 ft/s)	655 m (2148 ft)	669 m (2194 ft)
		10 m/s (33 ft/s)	1493 m (4897 ft)	747 m (2450 ft)
MMH (0.26 ppm)	1000 kg (2200 lbs)	2 m/s (6.6 ft/s)	641 m (2102 ft)	769 m (2522 ft)
		10 m/s (33 ft/s)	1452 m (4763 ft)	773 m (2535 ft)
NTO (1.0 ppm)	1200 kg (2640 lbs)	2 m/s (6.6 ft/s)	1230 m (4034.4 ft)	2574 m (8443 ft)
		10 m/s (33 ft/s)	5680 m (18630 ft)	3411 m (11188 ft)

Appendix B

The U. S. Air Force Toxic Chemical Dispersion Model (AFTOX) was used to predict downwind dispersion distances for propellant vapors that would be generated by worst case spills from NASA routine payload spacecraft. AFTOX was officially endorsed by the Air Weather Service in 1988 and is used extensively throughout the U. S. Air Force. It is a Gaussian puff/plume model designed to simulate a variety of releases including continuous or instantaneous, liquid or gas, surface or elevated, and point or area. It includes several evaporation models for predicting emission rates from liquid spills. AFTOX is a simple model that assumes a uniform windfield and flat terrain (Kunkel, 1991). This appendix provides the results of the AFTOX runs relevant to the NASA routine payload spacecraft. Worst case spills of three liquid propellants were considered: 1000 kg (2200 lb) of hydrazine, 1000 kg (2200 lb) of monomethylhydrazine (MMH), and 1200 kg (2640 lb) of nitrogen tetroxide (NTO). These are the maximum propellant loads for the routine payload spacecraft. Worst case assumptions were that the spills were instantaneous and unconfined, and that they completely evaporated without any mitigating actions such as removal, dilution, or neutralization. These worst case assumptions are very unlikely to occur considering the regulations governing the use and transport of these hazardous propellants. AFTOX was used to predict mean distances to selected downwind concentrations of each air toxin. Model output also provides a toxic hazard corridor distance that is the 90% probability distance. The selected concentrations used for this analysis were the Short-Term Emergency Guidance Levels (SPEGLs) for hydrazine (0.12 ppm 1-hour average), MMH (0.26 ppm 1-hour average), and nitrogen dioxide (1.0 ppm 1-hour average). The Committee on Toxicology, National Research Council, issues SPEGLs.

Four AFTOX model predictions were generated for each propellant at each launch site (CCAFS and VAFB). The four predictions at each site covered daytime releases at two different wind speeds (2 and 10 m/s; 7 and 33 ft/s) and nighttime releases at two different wind speeds (2 and 10 m/s; 7 and 33 ft/s). Daytime temperatures were assumed to be 32°C (90°F) at CCAFS and 20°C (68°F) at VAFB. Nighttime temperatures were assumed to be 5°C (41°F) at both sites. These meteorological conditions were selected to represent a variety of possible dispersion cases. Selection of other conditions would result in different model results.

AFTOX predicted the following results for spills at CCAFS: 1) an unconfined spill of 1000 kg (2200 lb) of hydrazine would produce a spill area of 107 m² (1150 ft²) and a mean hazard distance of up to 1493 m (4897 feet); 2) an unconfined spill of 1000 kg (2200 lb) of MMH would produce a spill area of 114 m² (1227 ft²) and a mean hazard distance of up to 1452 m (4763 feet); and 3) an unconfined spill of 1200 kg (2640 lb) of NTO would produce a spill area of 80 m² (861 ft²) and a mean hazard distance of up to 5680 m (18630 feet) for nitrogen dioxide. Note: AFTOX predicts that NTO liquid spills are gas releases at 32°C (90°F) ambient temperature. For modeling purposes, the gas was assumed to have a release duration of five minutes.

These mean hazard distances are for one-hour average concentrations. However, for spills that evaporated in less than one hour (many of the NTO spills) the vapor concentration averaging time calculated by AFTOX is the evaporation time rather than for one hour. Therefore, the calculated hazard distance for many of the NTO spills is much longer than the actual one-hour average hazard distance. This is another conservative factor in the AFTOX results.