

EvitaXL

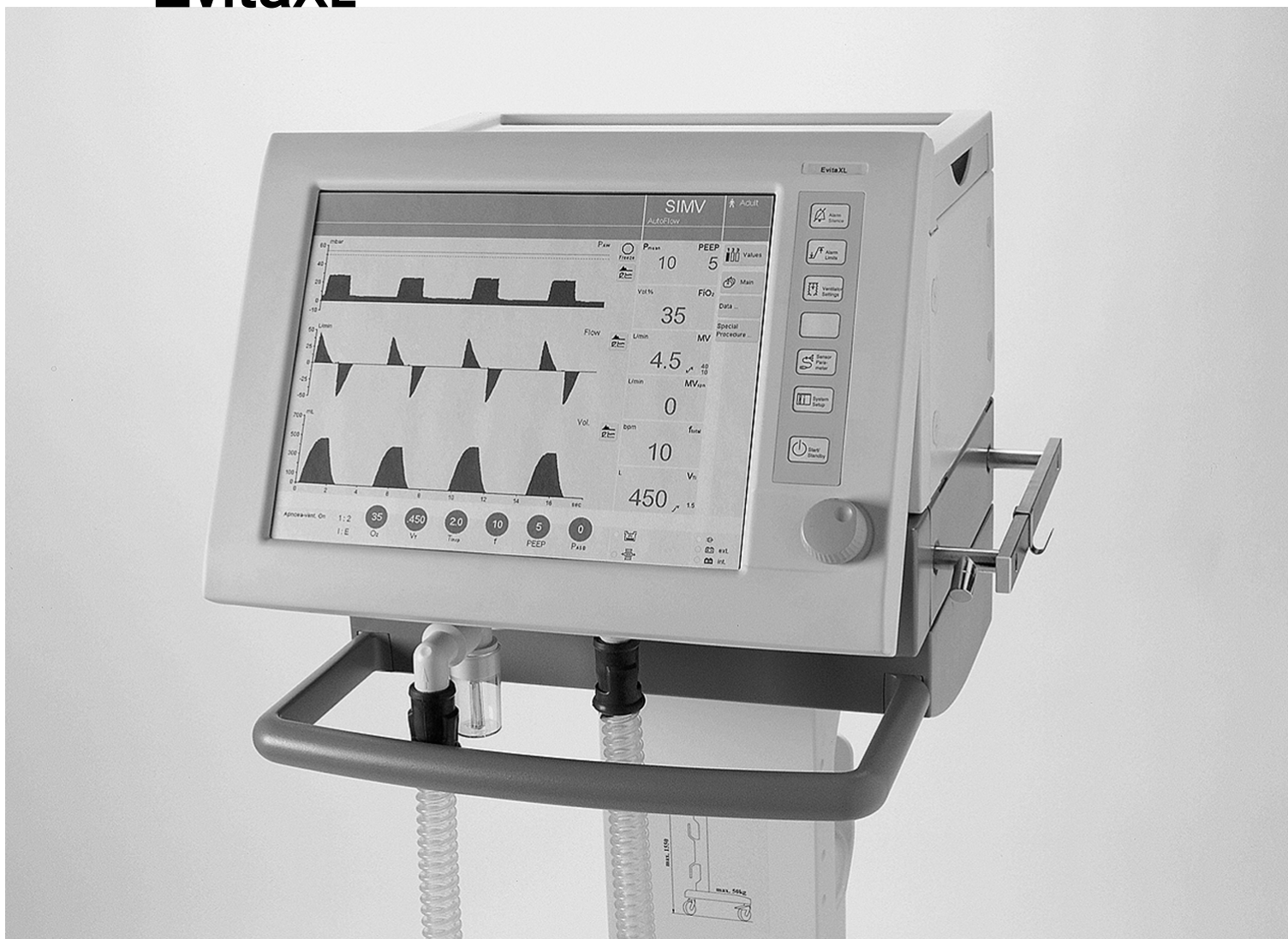

Intensive Care Ventilator Software 6.n Instructions for Use

Working with these Instructions for Use

Header line – the title... of the main chapter.

The title of the specific sub-section is printed underneath the main header – to help you find your way quickly from subject to subject.

Page body... the Instructions for Use

in combined text/illustrations. The information is expressed in the form of practical actions, giving the user direct hands-on experience in learning how to use the machine.

Left-hand column – the text...

provides explanations and instructs the user step-by-step in the practical use of the product, with short, clear instructions in easy-to-follow sequence.

Bullet points indicate separate actions. Where several actions are described, numbers are used both to refer to the relevant details in the illustrations and to specify the sequence of actions.

Right-hand column – the illustrations...

provide the visual reference for the text and make it easier to locate the various parts of the equipment. Elements mentioned in the text are highlighted. Unnecessary details are avoided. Screen displays prompt the user to proceed and confirm correct actions.

Preparing for use
Positioning the control unit

Preparing for use

- Always use properly prepared parts, see "Preparing", page 155.
- Hospital infection control regulations must be observed.

Positioning the control unit

- The control unit must not be stood up or leant against anything, nor may it be laid face downward! It must always be laid on its back when changing over.

Positioning on the unit

- Hook the control unit into the mount on EvitaXL until it engages.

To adjust the position:

- 1 Press and hold the segments on the right and left, at the same time tilting the control unit into the required position.

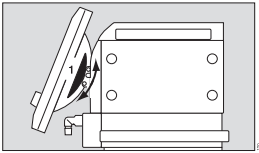

Positioning on the wall rail

- 2 Press and hold the segments on the right and left, tilting the control unit down completely at the same time.

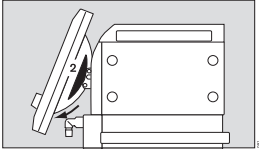

- 3 Press and hold the unlocking buttons on the right and left, lifting the control unit out of the mount on EvitaXL at the same time.

- Unwind the required length of cable.
- Hook the control unit into the wall rail and

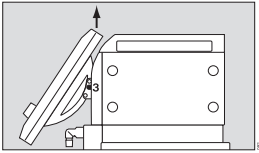

22

Instructions for Use EvitaXL

209

These Instructions for Use also apply to EvitaXL as well as Evita 4 and Evita 2 dura with the EvitaXL option.

Contents

For Your Safety and that of Your Patients	5
Intended Medical Application	7
Operating concept	11
Preparing for use	21
Operation	43
Configuration	125
Fault – Cause – Remedy	143
Preparing	155
Maintenance/Disposal	165
Mains power/DC power operation	169
Evita 4 Link (optional)	177
What's what	183
Technical Data	187
Description	207
Index	247

For Your Safety and that of Your Patients

Strictly follow the Instructions for Use

Any use of the apparatus requires full understanding and strict observation of these instructions. The apparatus is only to be used for purposes specified here.

Maintenance

The apparatus must be inspected and serviced regularly by trained service personnel at six monthly intervals. Repair and general overhaul of the apparatus may only be carried out by trained service personnel. We recommend that a service contract be obtained with DrägerService and that all repairs also be carried out by them. Only authentic Dräger spare parts may be used for maintenance. Observe chapter "Maintenance Intervals".

Accessories

Do not use accessory parts other than those in the order list. Even reusable accessories (e.g. after being prepared) have a limited service life. Wear may be increased and the service life reduced considerably by various factors when handling and preparing them (e.g. disinfectant residues corroding the material when autoclaving them). These parts must be replaced if signs of wear become visible, such as cracks, deformation, discoloration, peeling, etc.

Not for use in areas of explosion hazard

This apparatus is neither approved nor certified for use in areas where combustible or explosive gas mixtures are likely to occur.

Safe connection with other electrical equipment

Electrical connections to equipment which is not listed in these Instructions for Use should only be made following consultations with the respective manufacturers or an expert.

Liability for proper function or damage

The liability for the proper function of the apparatus is irrevocably transferred to the owner or operator to the extent that the apparatus is serviced or repaired by personnel not employed or authorized by DrägerService or if the apparatus is used in a manner not conforming to its intended use. Dräger cannot be held responsible for damage caused by non-compliance with the recommendations given above. The warranty and liability provisions of the terms of sale and delivery of Dräger are likewise not modified by the recommendations given above.

Dräger Medical AG & Co. KGaA

Safe use of the equipment

This equipment must only be used under the supervision of qualified medical staff, so that help is available immediately if malfunctions occur.

This equipment must not be used with flammable gases or anaesthetic agents. Danger of fire!

The equipment must not be used for nuclear resonance tomography (MRT, NMR, NMI)!

This may impair correct functioning of the equipment and endanger the patient.

The equipment must not be used in hyperbaric chambers!

This may impair correct functioning of the equipment and endanger the patient.

Correct functioning of the equipment may be impaired by operation of high-frequency electrosurgery units, defibrillators or short-wave therapy equipment and endanger the patient.

To ensure that EvitaXL cannot topple over, EvitaXL must not be tilted more than 5°!

The following must be observed during transportation of the ventilated patient.

- EvitaXL must not be placed on the bed while transferring a patient.
- EvitaXL must be secured so that it cannot topple over/fall down.
- Secure the accessories, see page 41.

When using EvitaXL in combination with other products and during patient transfers, the equipment's owner must ensure that it is adequately secured in accordance with the relevant fundamental requirements of Directive 93/42/EEC.

Medicaments and other substances based on inflammable solvents, such as alcohol, must not be used in the patient system. Danger of fire!

Adequate ventilation must be ensured when using inflammable substances for disinfection.

Do not use mobile telephones within 10 metres of ventilators!

Mobile telephones may impair the functionality of electro-medical equipment and endanger the patient .

General information on electromagnetic compatibility (EMC) according to the international EMC standard IEC 60601-1-2: 2001

Medical electrical equipment needs special precautions regarding electromagnetic compatibility (EMC) and needs to be installed and put into service according to the EMC information provided in the technical documentation available from DrägerService upon request.

Portable and mobile RF communications equipment can affect medical electrical equipment.



Pins of connectors identified with the ESD warning symbol shall not be touched and not be connected unless ESD precautionary procedures are used. Such precautionary procedures may include antistatic clothing and shoes, the touch of a ground stud before and during connecting the pins or the use of electrically isolating and antistatic gloves. All staff involved in the above shall receive instruction in these procedures.

Adequate ventilation monitoring

The following parameters are monitored by the built-in monitoring facilities of EvitaXL:

- Airway pressure PAW
- Expiratory minute volume MV
- Inspiratory tidal volume, V_{Ti}
- Inspiratory O₂ concentration FiO₂
- Inspiratory breathing gas temperature T
- Expiratory CO₂ concentration, etCO₂ (optional)
- Apnoea time
- Tachypnoea

Changes in these parameters may be caused by:

- Acute changes in the patient's condition
- Incorrect settings and faulty handling
- Equipment malfunctions
- Failure of power and gas supplies

If a fault occurs in this equipment, separate measuring instruments should be used.

During the O₂ Therapy, the monitoring functions of EvitaXL are restricted. Monitoring of SpO₂ and the pulse is only available with the appropriate option.

Back-up ventilation with an independent manual ventilation device

If a fault is detected in EvitaXL so that its life-support functions are no longer assured, ventilation using an independent ventilation device must be started without delay – if necessary with PEEP and/or an increased inspiratory O₂ concentration (e.g. with the Resutator MR 100).

* Dräger medical equipment meets the requirements for immunity to interference in accordance with the specific product standards and EN 60601-1-2 (IEC 60601-1-2). Depending on the type of mobile telephone used and on the application situation, however, field strengths exceeding the values specified in the applicable standards may develop in the immediate vicinity of the mobile telephone and therefore lead to faults and malfunctions.

Intended Medical Application

Intended Medical Application 8

Intended Medical Application

EvitaXL – long-term ventilator for intensive care.
For adults, children and neonates.
For premature babies with the "NeoFlow" option.

With the following ventilation modes

IPPV (Intermittent Positive Pressure Ventilation)

Volume-controlled ventilation with fixed mandatory minute volume.

With the options:

- **CPPV (Continuous Positive Pressure Ventilation)**
Controlled ventilation with continuous positive airway pressure
- **PLV (Pressure Limited Ventilation)**
Pressure limited constant-volume ventilation
- **AutoFlow®**
for automatic regulation of "Insp. Flow" and "P_{insp}"
- **IRV (Inversed Ratio Ventilation)**
Ventilation with inversed inspiration/expiration ratio.

SIMV (Synchronized Intermittent Mandatory Ventilation)

Combines mechanical (volume-controlled) ventilation with spontaneous breathing.

With the options:

- **PLV (Pressure Limited Ventilation)**
Pressure limited constant-volume ventilation
- **AutoFlow®**
for automatic regulation of "Insp. Flow" and "P_{insp}".

MMV (Mandatory Minute Volume Ventilation)

Spontaneous breathing with automatic adjustment of mandatory ventilation to the patient's minute volume requirement.

With the options:

- **PLV (Pressure Limited Ventilation)**
Pressure limited constant-volume ventilation
- **AutoFlow®**
for automatic regulation of "Insp. Flow" and "P_{insp}".

SB (Spontaneous Breathing)

Spontaneous breathing at ambient pressure.

CPAP (Continuous Positive Airway Pressure)

Spontaneous breathing with positive airway pressure.

ASB (Assisted Spontaneous Breathing)

Pressure-assisted spontaneous breathing.

BIPAP* (Biphasic Positive Airway Pressure)

Pressure-controlled ventilation combined with free spontaneous breathing during the complete breathing cycle, and adjustable pressure increase to CPAP level.

BIPAP_{Assist} (Biphasic Positive Airway Pressure Assisted)

Pressure-controlled assisted ventilation.

APRV (Airway Pressure Release Ventilation)

Spontaneous breathing on two pressure levels with long time ranges – independently adjustable.

PPS – Proportional Pressure Support (optional)

For differentiated proportional support of spontaneous breathing with pathological compliance and/or resistance.

ILV

Independent Lung Ventilation,
Separate, differentiated, synchronised ventilation with two Evita units, independently ventilating each lung.

Supplements

Automatic Tube Compensation ATC (optional)

Can be used with all ventilation modes.
ATC Compensates for the resistance of the ETT or Tracheal Tube.

Apnoea Ventilation

For switching over automatically to volume-controlled mandatory ventilation, if breathing stops.
If apnoea occurs, EvitaXL emits an alarm after the preset alarm period ($T_{Apnoea} \sqrt{E}$) and starts volume-controlled ventilation.

NIV mask ventilation (optional)

Non-invasive ventilation

For ventilation with a nasal or facial mask to support non-invasive ventilation of patients with spontaneous breathing.
Choice between mask ventilation and ordinary ventilation of intubated patients.

* Licensed trademark

Lung Protection Package (optional)

- QuickSet
Direct adjustment of setting,
- PressureLink
Linking of the PEEP/P_{insp} settings,
- Recruitment trends and
- Low Flow PV-Loop

Aid for performing Recruitment procedure and for the optimisation of Ventilator settings.

Diagnostic functions

Intrinsic PEEP-measurement

For determining intrinsic PEEP and measuring trapped volume.

Occlusion pressure measurement

For evaluating breathing drive during spontaneous breathing.

Negative Inspiratory Force NIF

For measuring the patient's maximum inspiratory effort following expiration.

Monitoring:

Airway pressure PAW
Expiratory minute volume MV
Inspiratory tidal volume VT_i
Inspiratory O₂ concentration FiO₂
Inspiratory breathing gas temperature T
Apnoea time
Tachypnoea
Expiratory CO₂ concentration etCO₂ (optional)

DC power supply

Integrated DC power supply supplying EvitaXL with power from two DC sources:

- Via two 12 V lead-gel batteries integrated in the DC power supply,
and
- optionally via additional external 12 V or 24 V lead-gel batteries.

For uninterrupted operation following failure of the mains power supply, by automatically switching over to the external or integrated battery.

For supplying power from the integrated batteries or additionally from external batteries during transport within the hospital.

Evita 4 Link (optional)

Interface card

For output of measured values, status messages and alarm messages to on-line equipment for monitoring, documentation or processing.

O₂ Therapy (optional)

Continuous flow application with adjustable O₂ concentration and adjustable flow for the O₂ Therapy function for patients with independent breathing and using oxygen masks.

SmartCare/PS (optional)

Knowledge-based system for automating clinical guidelines.

Automatic gas switch-over

In the event of a gas failure, the EvitaXL automatically switches over to the remaining gas supply available.

Uses

On the intensive-care ward or in the recovery room.
While transferring ventilated patients within the hospital.

Operating concept

Operating concept	12
Control unit	12
The screen... ..	13
Fixed function keys... ..	14
On-screen controls	14
Optional operating concept	18
QuickSet	18
PressureLink	19
QuickSet + PressureLink	20

Operating concept

Control unit



The control unit is characterised by the small number of operating elements, its clear layout and easy operation.

Its main elements are:

- 1 Large screen with all the information and controls needed for ventilation.
- 2 Fixed function keys beside the screen – for rapid access to major functions.
- 3 Central rotary knob for selecting and confirming settings on the screen.

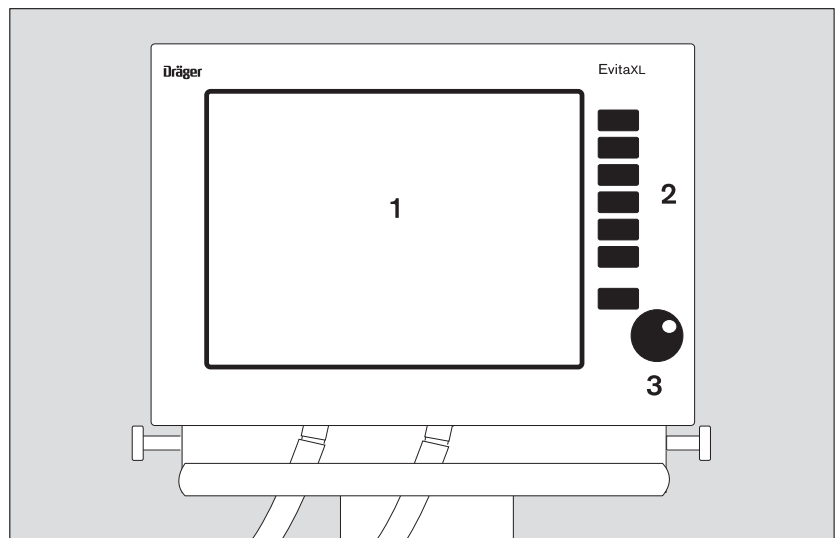

The screen...



displays all the most important ventilation data at a glance.

The various screen pages have the same layout with specific data always presented in the same place.

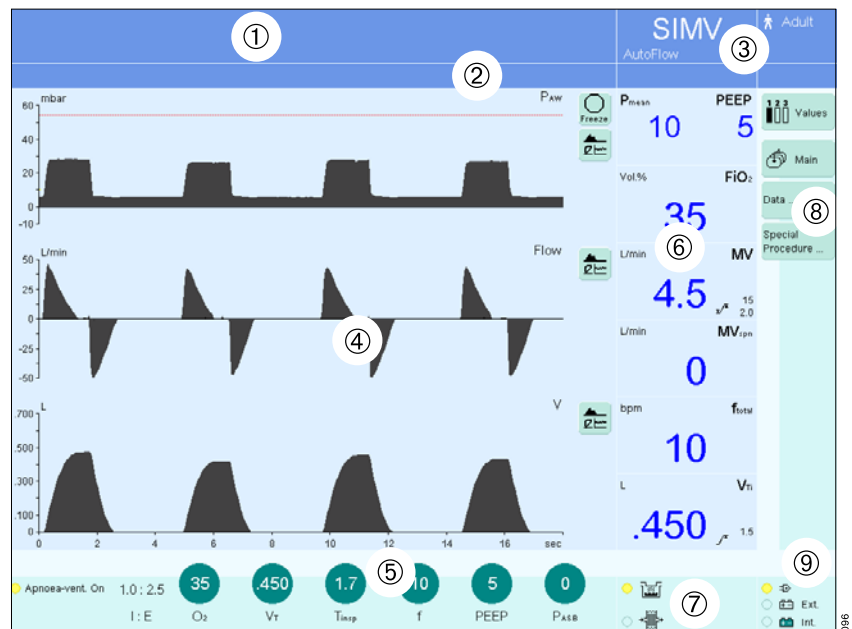
- 1 Alarm messages
- 2 Operator prompts
- 3 Therapy status with ventilation mode, e.g. SIMV, ventilation mode supplements, e.g. AutoFlow®, patient mode, e.g. Adult  for adults
- 4 Curves, loops and trends visualizing the ventilation, e.g. the real-time curves PAW (t), Flow (t), VT (t) (can be configured)
- 5 Presentation of ventilation parameters for the active ventilation mode and its supplements
- 6 Essential, measured ventilation values (can be configured)
- 7 Humidification type and status
- 8 Touch-sensitive screen keys for the specific screen pages (can be configured)
- 9 Power supply indication









To select a screen page:

- Touch the relevant screen key:
- »  **Main**« to select the main screen.
- »  **Values**« to select a different group of measured values in the field for numerical values.
- » **Data...**« to display all measured values, the logbook or trends on an additional card.
- » **Special Procedure...**« to select additional functions, e.g. medicament nebulisation and oxygenation for bronchial suctioning.

Other screen keys can be configured individually, see Configuration, page 125.

Fixed function keys...

are provided for rapid access to major on-screen functions, such as selection of the ventilation mode, setting the ventilation parameters or adjusting the alarm limits:

- 1 »  **Alarm Silence**« for suppressing the acoustic alarm tone for two minutes.
- 2 »  **Alarm Limits**« for adjusting the alarm limits.
- 3 »  **Ventilator Settings**« for setting the ventilation mode and ventilation parameters.
- 4 Unassigned key for future functions
- 5 »  **Sensor Parameter**« for calibrating the sensors and for activating/deactivating the monitoring functions.
- 6 »  **System Setup**« for configuring system functions.
- 7 »  **Start/Standby**« for selecting standby mode or normal operation.

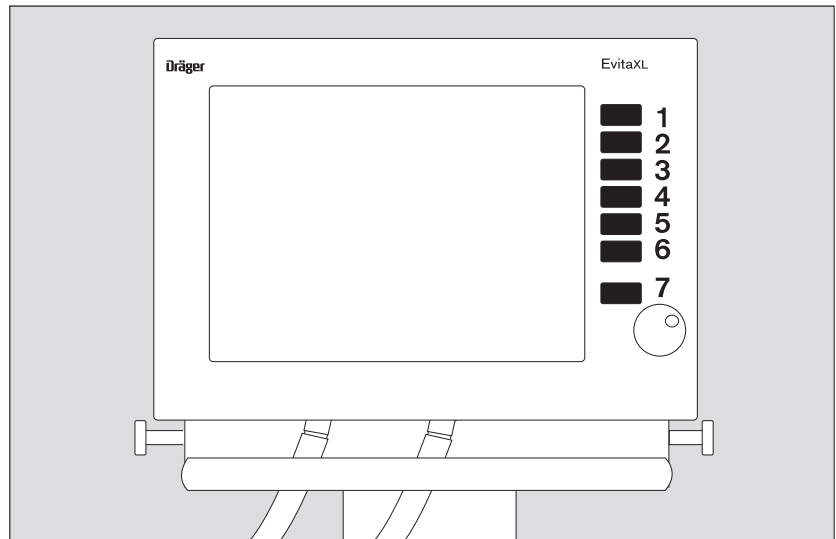

On-screen controls

- 8 The ventilation parameters required for the active ventilation mode are displayed by EvitaXL in a separate field at the bottom of the main screen in the form of virtual screen knobs with the respective settings.

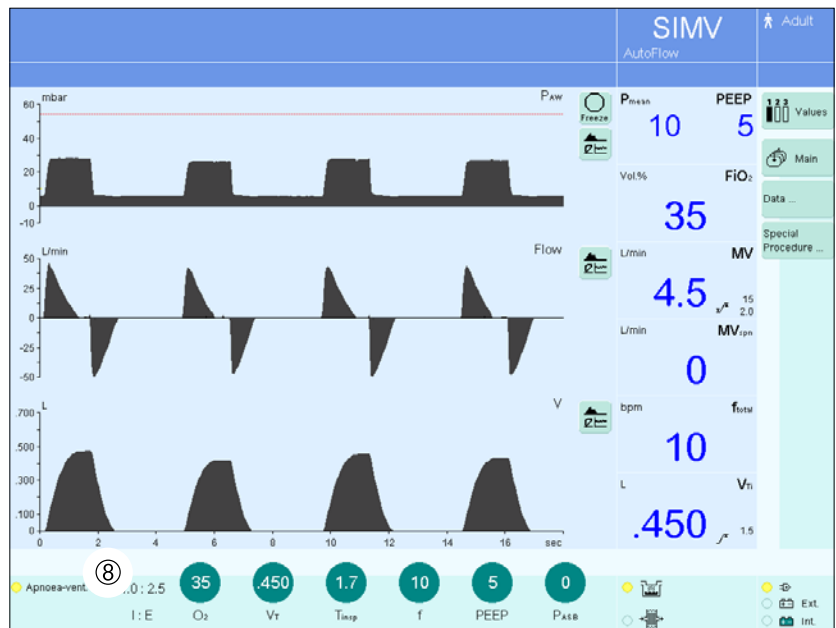

To set the ventilation mode and ventilation parameters:

- 1 Press » Ventilator Settings«
- or
- touch one of the virtual screen knobs at the bottom of the screen.

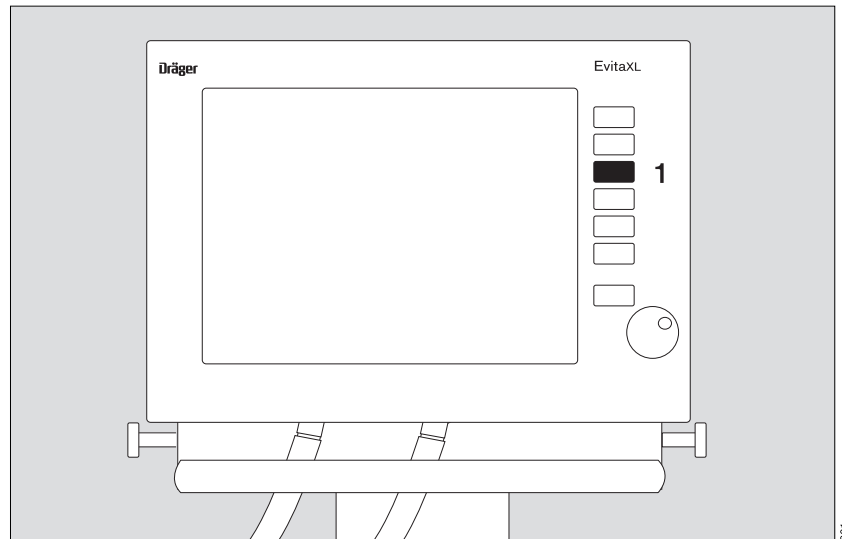

EvitaXL displays the menu »Ventilator Settings« in the bottom part of the screen (example):

the screen knobs and screen keys are displayed in the form of horizontal and vertical tabs as on a file card.

- Horizontal screen keys for selecting the ventilation mode.
- Vertical screen keys for selecting additional settings.

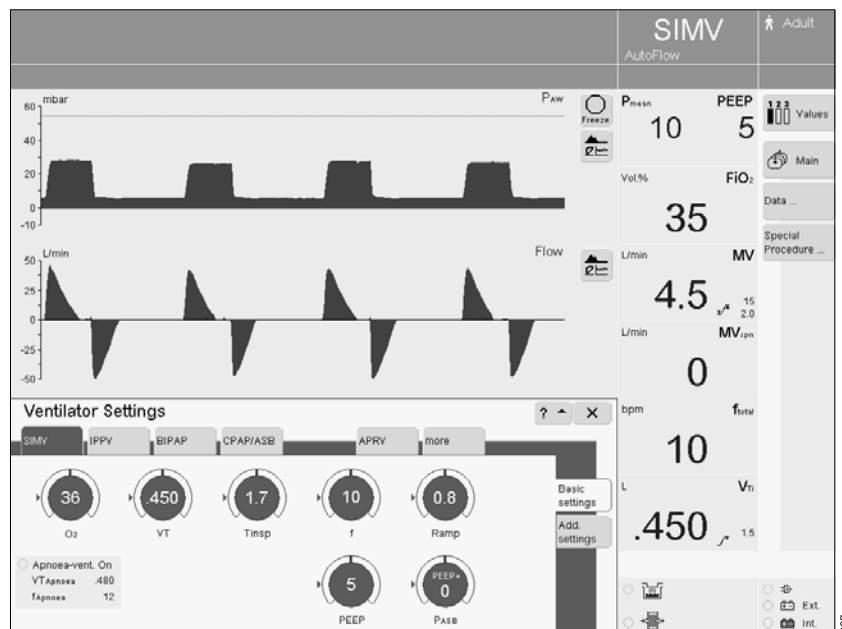

The touch-sensitive screen controls are used in the same way as real keys and knobs:

Touching these controls with a fingertip is equivalent to pressing a key or taking hold of a knob.

Settings are made and confirmed by turning and pressing the central rotary knob.

The status of the screen controls is indicated by colours:

grey = not available

yellow = available

pale green = available but not active

dark green = available and active

Screen keys:

- 1 select = touch,
- 2 screen key turns yellow,
- 3 confirm = press rotary knob,
- 4 screen key turns pale/dark green.

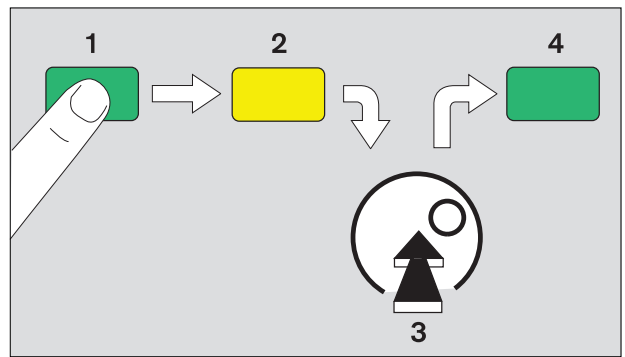

Screen knobs:

- 1 select = touch,
- 2 screen knob turns yellow,
- 3 set = turn rotary knob,
- 4 confirm = press rotary knob,
- 5 screen knob turns pale/dark green.

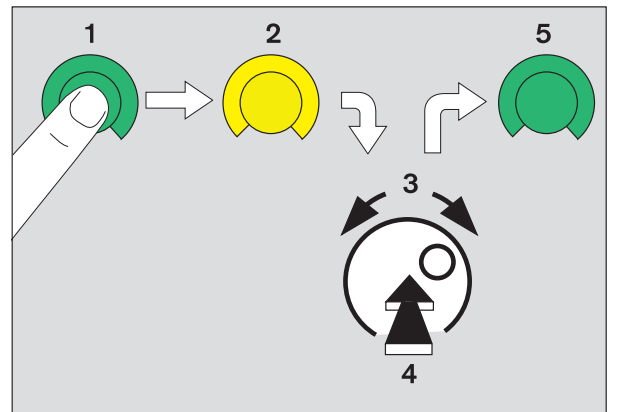

To set ventilation parameters directly:

On the main screen (example):

- Touch the required screen knob in the row of screen knobs and settings displayed.
- The menu »Ventilator Settings« is displayed by EvitaXL. The selected screen knob is already yellow and can be adjusted directly.

Display (example):

- Set = turn central rotary knob, confirm = press central rotary knob.

The colour of the screen knob changes to dark green – the setting is now effective.

To view additional text information:

- Touch the screen key »?▲«.

To quit the menu:

- Press the screen key »X«.

Arrows (▶) beside the scales on the screen knobs indicate the initial values valid when the equipment is switched on. These values can be adjusted specifically as required by the hospital, see Configuration, page 125.

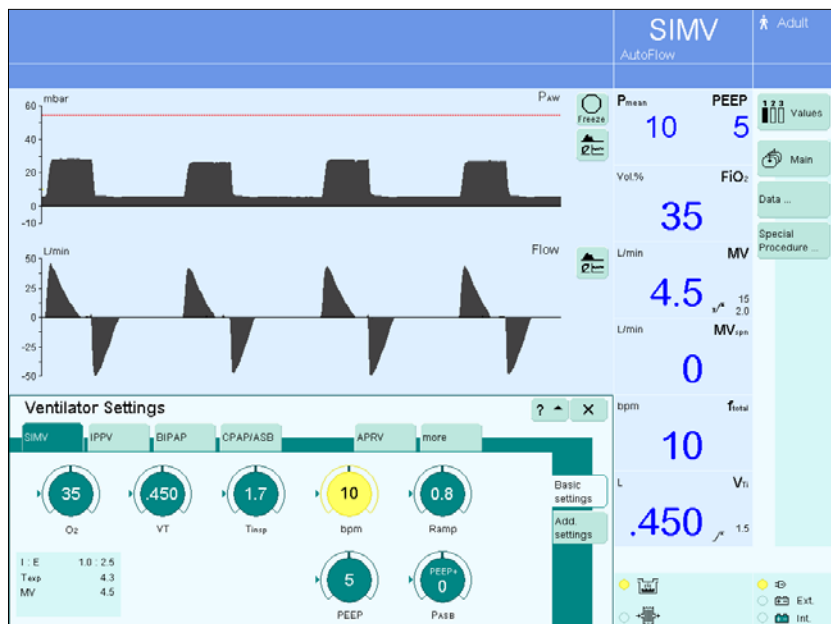

Optional operating concept

QuickSet*

Direct adjustment of PEEP or P_{insp}

Direct adjustment of PEEP is possible in all ventilation modes.

Direct adjustment of P_{insp} is possible in BIPAP and BIPAP_{Assist}.

- Touch the screen key »PEEP« or »P_{insp}« in the respective ventilation mode.

- Depress rotary knob and hold down for 3 secs.

The adjuster changes to green with a yellow edge. Direct adjustment is active.

- Keep rotary knob depressed and turn it. Set »PEEP« or »P_{insp}«.

The set value is now effective.

On releasing the rotary knob, »PEEP« or »P_{insp}« can still be set directly:

- Depress again the rotary knob and turn it.

Exceeding the standard setting range:

- Release rotary knob for a short moment; the standard setting range can be exceeded.

Set »PEEP« or »P_{insp}«:

- Depress again the rotary knob and turn it.

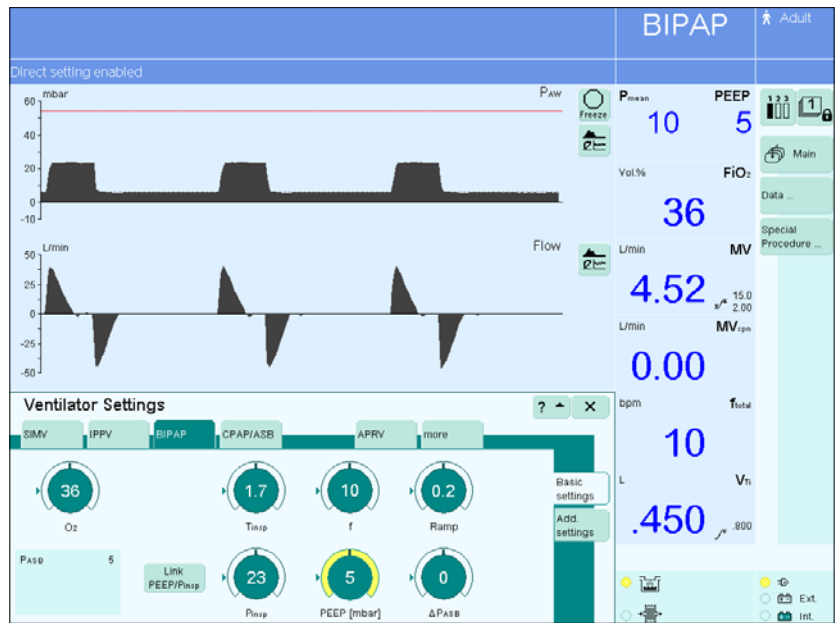

* Lung Protection Package option

PressureLink*

Linked adjustment of PEEP and P_{insp}

- Touch screen key »PEEP« or »P_{insp}«.
- Touch screen key »Link PEEP/P_{insp}«.
- Set »PEEP« and »P_{insp}« = turn rotary knob. The values are adjusted simultaneously. The difference remains constant.
- Confirm new settings = press rotary knob.

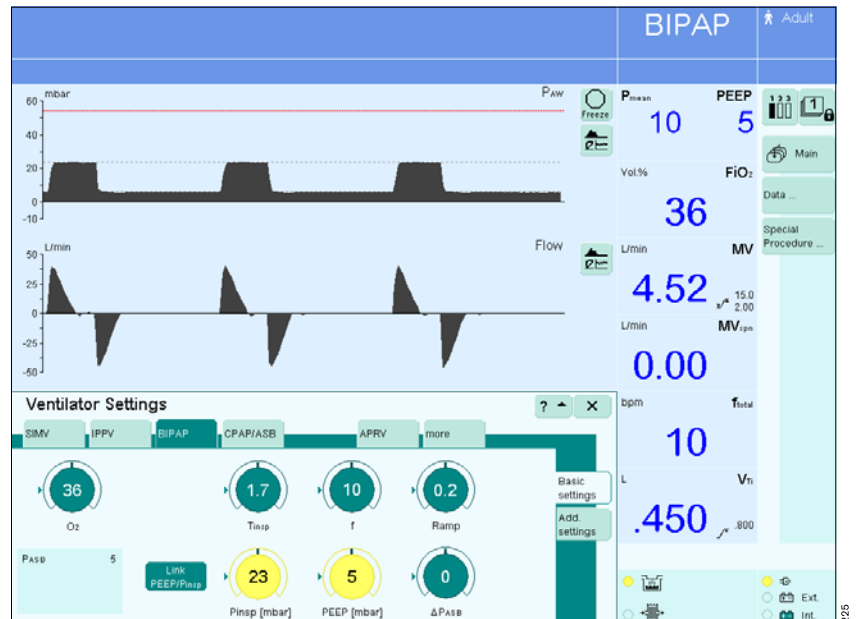

* Lung Protection Package option

QuickSet + PressureLink*

Setting PEEP and P_{insp} directly and linked:

- Touch screen key »PEEP« or »P_{insp}«.
- Touch screen key »Link PEEP/P_{insp}«.
- Depress rotary knob and hold down for 3 secs.

The adjusters change to green with a yellow edge. Direct adjustment is active.

- Keep rotary knob depressed and turn it. Set »PEEP« and »P_{insp}«.

The values are set simultaneously and are immediately effective.

On releasing the rotary knob, »PEEP« and »P_{insp}« can still be set directly:

- Depress again the rotary knob and turn it.

Exceeding the standard setting range:

- Release rotary knob for a short moment; the standard setting range can be exceeded.

Set »PEEP« and »P_{insp}«:

- Depress again the rotary knob and turn it.

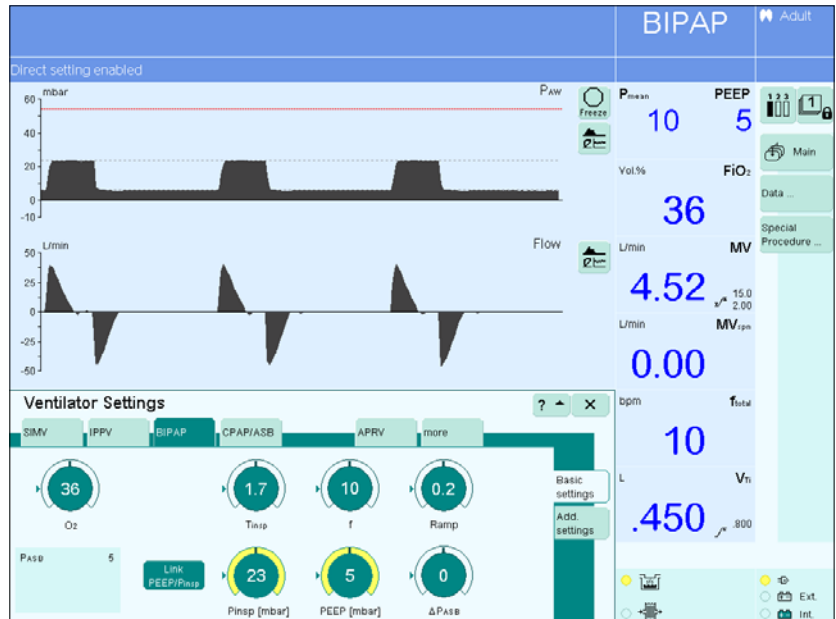

* Lung Protection Package option

Preparing for use

Preparing for use	22
Positioning the control unit	22
Fitting the expiration valve	23
Fitting the flow sensor	23
Fitting O ₂ sensor capsule	24
Using HME, bacterial filters and hose systems	25
Ventilating adults and children	26
Ventilating infants	28
Fitting CO ₂ cuvette and CO ₂ sensor (optional)	29
Power supply and connections	30
Gas supply	31
Connecting Evita Remote (optional)	31
Connecting the nurse call (optional)	33
Device Check	34
Leak test	39
Entering the humidifier type	40
Application mode Tube/Mask (optional)	40
Ventilation while transferring a patient within the hospital	41

Preparing for use

- Always use properly prepared parts, see "Preparing", page 155.
- Hospital infection control regulations must be observed.

Positioning the control unit

- The control unit must not be stood up or leant against anything, nor may it be laid face downwards! It must always be laid on its back when changing over.

Positioning on the EvitaXL

- Hook the control unit into the mount on EvitaXL until it engages.

To adjust the position:

- 1 Press and hold the segments on the right and left, at the same time tilting the control unit into the required position.

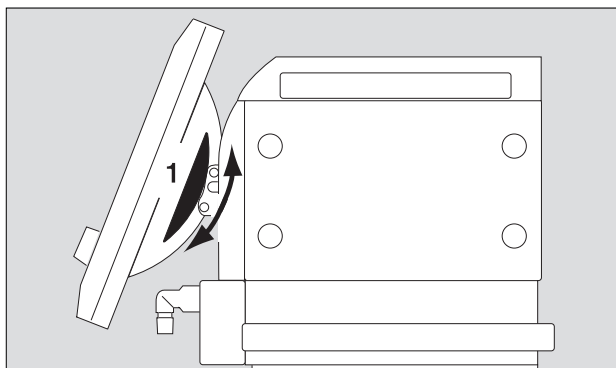

Positioning on the wall rail

- 2 Press and hold the segments on the right and left, tilting the control unit down completely at the same time.

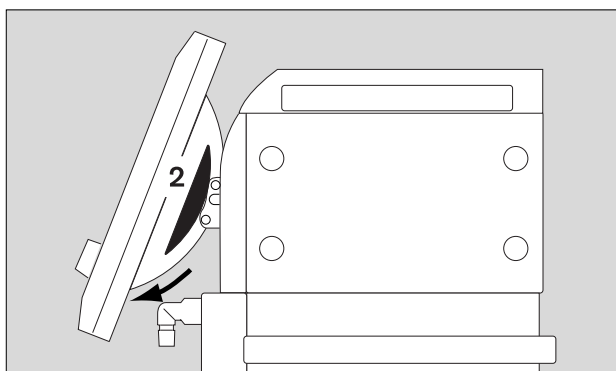

- 3 Press and hold the unlocking buttons on the right and left, lifting the control unit out of the mount on EvitaXL at the same time.

- Unwind the required length of cable.
- Hook the control unit into the wall rail and

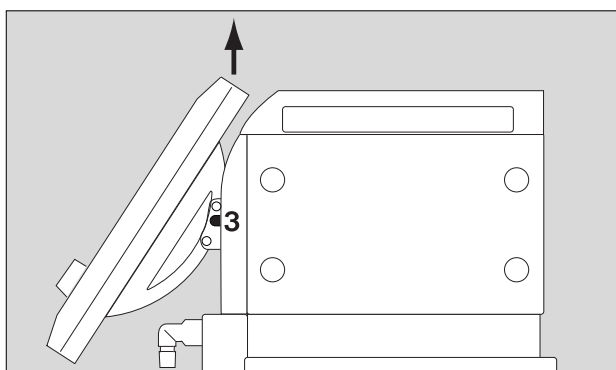

- 1 lock it in position = pull tab under the holder down and turn it towards the wall rail.

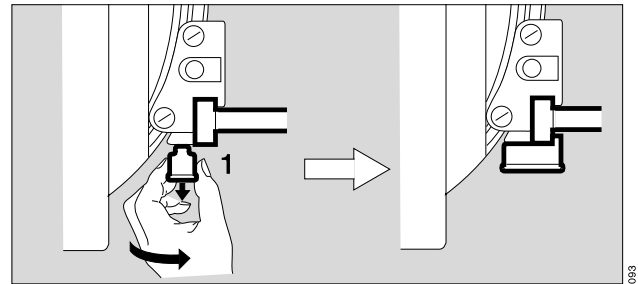

Fitting the expiration valve

- 2 Tilt the control unit upwards, pressing the segments on the right and left at the same time.
- 3 Push the expiration valve as far as it will go into the mounting. Check that it is properly secured by gently pulling the port.

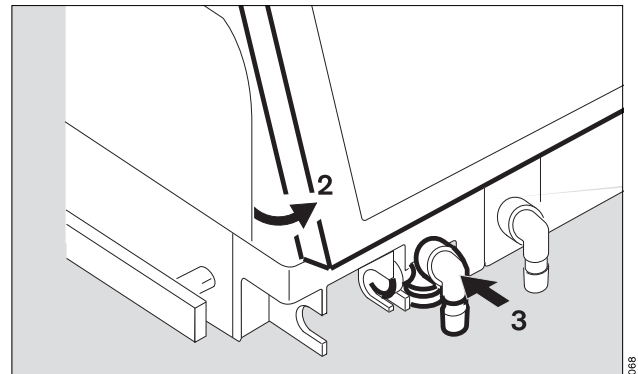

Fitting the flow sensor

- 4 Push socket to left as far as it will go.

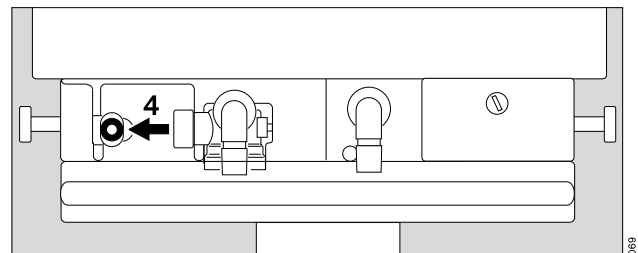

- 5 Fit flow sensor – with the connector facing towards the ventilator – into the mounting and push it into the socket as far as it will go.
Then:
- 6 Push flow sensor to the right as far as it will go into the rubber lip of the expiration valve.

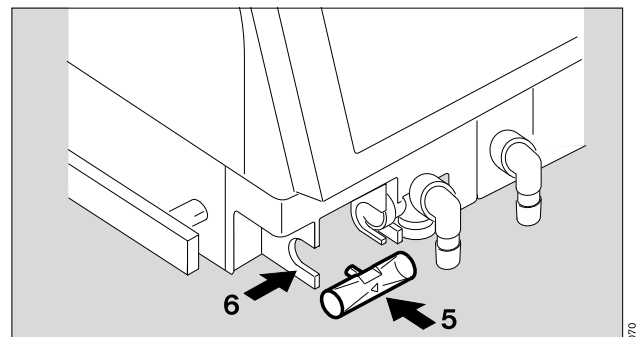

Fitting O₂ sensor capsule

- when using the system for the first time
 - when the display reads:
O₂ measurement inop
 - when calibration can no longer be performed
-
- Ensure device is in standby or ventilator is switched off.
 - Tilt the control unit upwards, pressing the segments on the right and left at the same time.
- 1 Turn the inspiratory port to the left.
 - 2 Use coin to loosen screw, and remove protective cover.
 - 3 Loosen the two knurled screws and open the sensor housing.
 - 4 Remove old sensor capsule and fit a new capsule. The end with the circular tracks remains visible.
- 3 Close the sensor housing securely with the two knurled screws.
 - 2 Screw protective cover back in place.
- Dispose of the used O₂ sensor capsule, page 168.

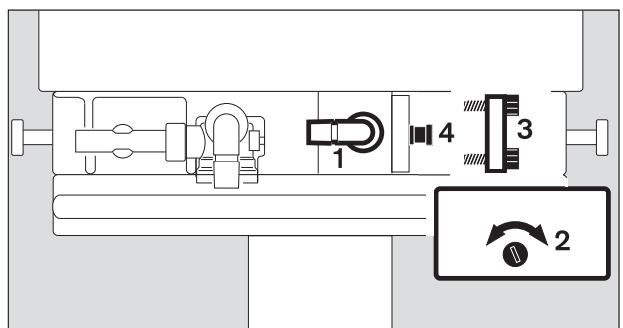

Using HME, bacterial filters and hose systems*

Additional components in the breathing system or components which diverge from the standard hose system can considerably increase the inspiratory and expiratory breathing resistance and exceed standard requirements.

Examples: Insp./exp. filters, HME**, coaxial hoses

In general, the EvitaXL is designed to minimise the breathing effort made by the patient and is therefore not intended for the use of insp./exp bacterial filters.

The use of bacterial filters or HMEs therefore requires particular care and monitoring by the user. Especially during medication nebulisation and humidifying, the resistance of the expiratory filter may increase gradually.

A higher breathing resistance leads to a greater breathing and trigger effort during assisted ventilation. Under unfavourable conditions, this can lead to an undesirable intrinsic PEEP. This can be recognised by the fact that the expiratory flow does not return to "0" at the end of expiration. If the PEEP is unacceptably high, it is indicated by the alarm »PEEP high !!!«. The current PEEP is then approx. 8 mbar above the set PEEP. Check and replace the bacterial filter or HME if they are the cause of the PEEP alarm.

A breathing resistance in the patient connection cannot be monitored directly by the ventilator. For this reason:

- Determine inspiratory and expiratory breathing resistance in the patient system before ventilation in standby by means of the device check.
- Check the condition of the patient and the ventilator's measured values for volume and resistance frequently.
- Observe the Instructions for Use for the HME, filter and coaxial hose systems in use.
- Do not use an HME together with a medicament nebuliser or breathing gas humidifier. This can lead to a greater breathing resistance.

* Only applies to hose systems which are not described in these Instructions for Use.

** Heat moisture exchanger

Ventilating adults and children

- Set the ventilator to breathing gas humidifier, see page 40.
From 100 mL tidal volume V_T upwards:
Patient mode: »Adults«

- **Do not use a heat and moisture exchanger at the same time as a humidifier! Risk of increased breathing resistance because of condensation.**

Connecting Aquapor EL humidifier

Prepare Aquapor EL by following the relevant Instructions for Use.

- 1 Hang Aquapor EL onto the rail and tighten the screws.
- 2 Insert elbow connector into Aquapor EL.
- 3 Insert the double connector into the elbow connector.
- 4 Fill the Aquapor EL bowl up to the upper filling mark with sterile Aquadest.

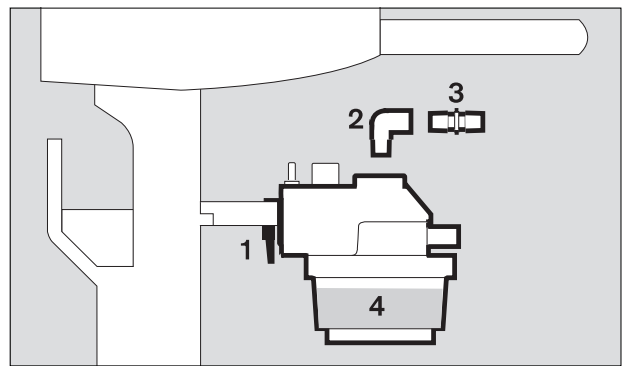

Connecting ventilation hoses

- Do not use antistatic or conductive hoses*.

Depending on the desired position of the ventilator in relation to the bed, the hinged arm can be fitted to either side of the machine.

Attachment on **left-hand** side:

- 5 Turn both ports to the left.
- 6 Turn Aquapor EL to the left.

The following description applies when the ventilation hoses have been attached on the **left-hand** side.

Whenever the ventilation hoses or humidifier have been changed:

- Perform a leak test, page 39.

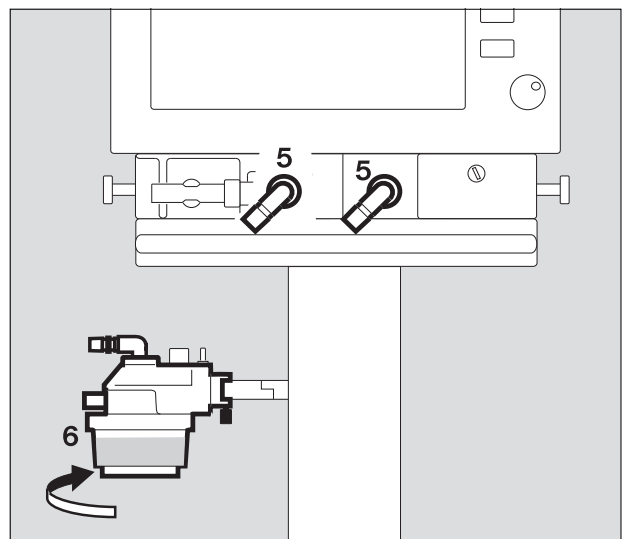

* DIN VDE 0750 section 215:
The use of anti-static or electrically conductive material in the breathing system of the lung ventilator is not considered conducive to greater safety. On the contrary, the use of these materials increases the danger of electric shock to the patient and of fire due to the presence of oxygen.

- 1 Hang the hinged arm from the rail on the left-hand side and tighten screws.
- Fit the ventilation hoses. Check the hose lengths (metres).
- 2 Turn ports in direction of hoses.
- 3 Install water traps in vertical position.
- 4 Connect the Y-piece, with the rubber sleeve of the Y-piece on the inspiratory side.
- 5 Insert the Y-piece in the opening of the hinged arm.

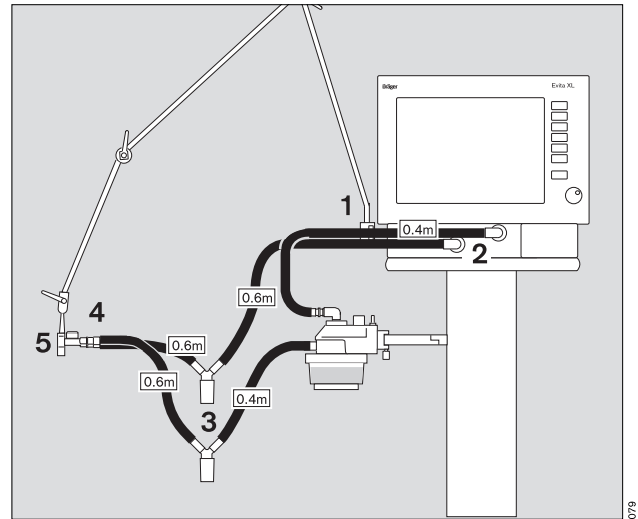

Fitting temperature sensor

- 6 Push sensor as far as it will go into the rubber sleeve on the inspiratory side of the Y-piece. Align the Y-piece so that the sensor is at the top in order to avoid condensation in the sensor.
- 7 Attach the sensor cable with hose clips.

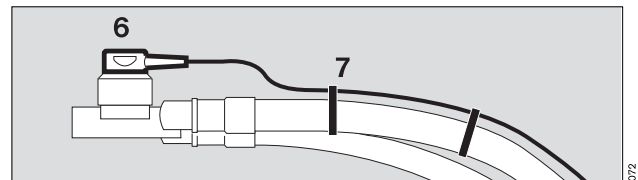

- 8 Insert the connector for the temperature sensor into the socket »Temp  « at the rear of EvitaXL.

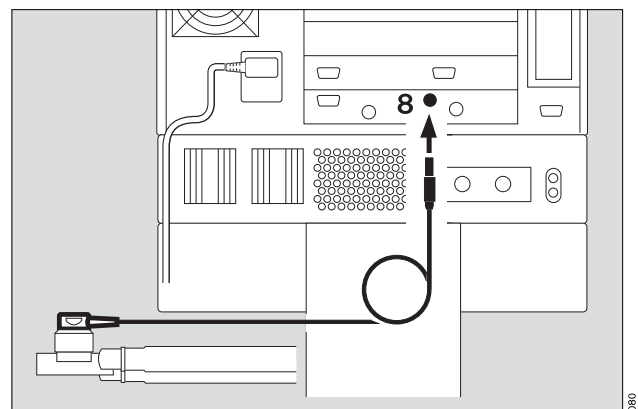

Ventilating infants

- Set the ventilator to breathing gas humidifier, see page 40.
Up to 300 mL tidal volume VT:
Patient mode: »Paediatric«

- **Do not use a heat and moisture exchanger at the same time as a humidifier! Risk of increased breathing resistance because of condensation.**

Fitting humidifier and ventilation hoses

- Prepare the "Fisher & Paykel MR 850" humidifier in accordance with the separate Instructions for Use.
- 1 Clamp the humidifier to the stand under the apparatus and screw firmly into place.
- 2 Clamp the articulated arm to the left-hand rail and screw firmly into place.
- Fit the ventilation hoses. Check the hose lengths (metres).
- 3 Fit the water trap in the vertical position.
- **Do not place any containers with liquid on or above the ventilator!**
Any leaking or spilled liquid could cause malfunctions!

Whenever the ventilation hoses or humidifier have been changed:

- Perform a leak test, page 39.

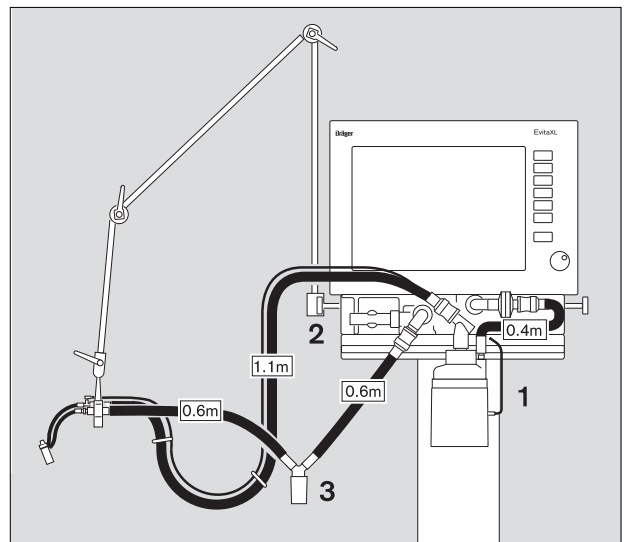

Fitting CO₂ cuvette and CO₂ sensor (optional)

- 1 Fit the cuvette to the patient connection of the Y-piece, with the cuvette windows facing the side.
- 2 Push the CO₂ sensor on to the cuvette, with the cable trailing towards EvitaXL.

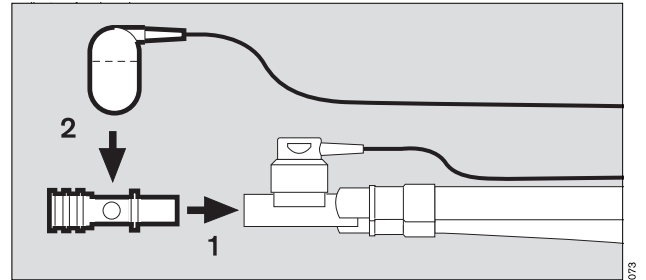

- 3 Insert the connector for the CO₂ sensor in the »CO₂ « socket on the rear of the ventilator.

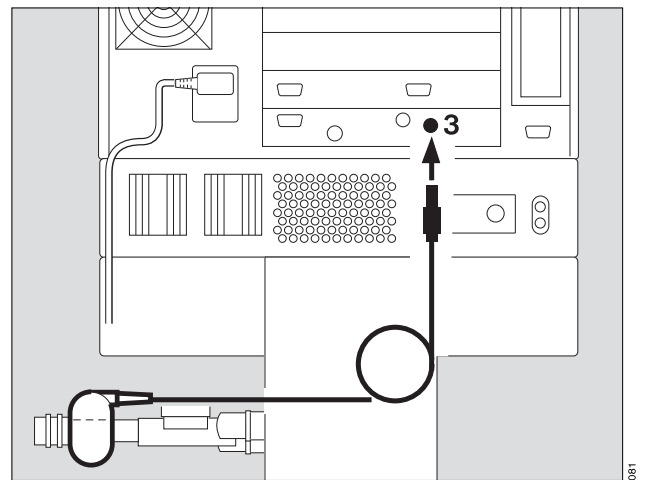

Power supply and connections

Electrical power supply

Either : 220 V to 240 V

or : 100 V to 127 V

- Insert the plug in the mains socket, the yellow indicator lights up.

For operation with DC power supply and external battery (optional)

- Connect optional external battery via cable, see "DC power operation", page 170.

Note on the use of a socket strip for ancillary equipment

Connecting other equipment to the extension socket strip may cause the patient leakage current to rise above the permitted values if a protective earth conductor should fail. The risk of electric shock cannot be excluded in such cases.

Temporary interruption of power supply

e.g. if hospital reserve power supply is activated.

Without optional Evita DC power supply:

During an interruption of the power supply, EvitaXL outputs a continuous alarm tone for max. 2 minutes. The duration of this alarm tone may be shorter if EvitaXL was switched on for less than 15 minutes.

EvitaXL tolerates power interrupts lasting less than 10 milliseconds – without influencing ventilation.

In the case of power interrupts lasting longer than 10 milliseconds, the machine restarts with a short self-test lasting about 8 seconds – ventilation is continued with the same values that were set before the power interruption. If a lower alarm limit has been set for the minute volume, the »**MV low !!!**« alarm is activated until the measured value has risen above the lower alarm limit.

With optional Evita DC power supply:

See chapter "DC power operation", page 170.

Other equipment, e.g. printers, may only be connected to the COM port if EvitaXL is connected to the mains power supply via a mains power cable or if it has been earthed via the earth connection on the back of EvitaXL.

Electric power may pose a hazard in all other cases.

Gas supply

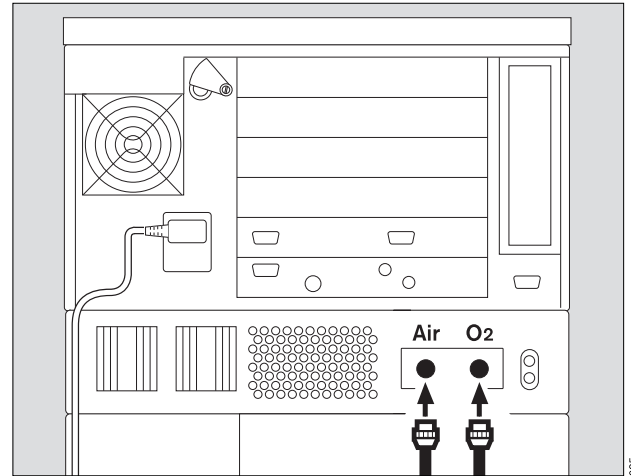

- Screw the connecting hoses for medical air (air) and oxygen (O₂) from the piped supply into the back panel of EvitaXL and plug their connectors into the terminal units. The compressed gases must be dry and free from dust and oil. Gas pressure must be 3 to 6 bar.



Connecting Evita Remote (optional)

- The plug-in card for Evita Remote may only be installed and programmed by specialists.

For remote control of EvitaXL via the Remote Pad for parallel, remote operation of the following LED and key functions:

- 1 red LED – to indicate warning messages
- 2 yellow LED – to indicate caution and advisory messages
- 3 » Alarm Silence« key – to suppress the alarm tone for approx. 2 minutes
- 4 »Alarm Reset« key – to acknowledge alarm messages
- 5 » Neb.« key – to start and end medicament nebulisation
- 6 »O₂ ↑ suction« key – for oxygenation for bronchial suctioning
- 7 »Insp. hold« key – for sustained, manually induced inspiration
- 8 »Exp. hold« key – for extended and sustained expiration

The function of the respective LEDs and keys is the same as on EvitaXL and is described in the application chapters of these Instructions for Use.

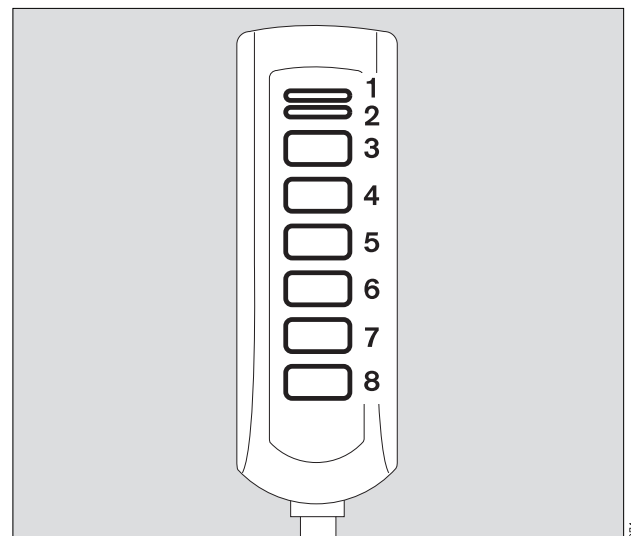

Connection

- 1 Plug the lead of the Remote Pad into the socket »  « on the rear of EvitaXL.
The connector can be plugged in or unplugged at any time.
This does not influence the operation of EvitaXL.

- Hook holder onto a standard rail and clamp into place.
- Hang Remote Pad into holder from above.

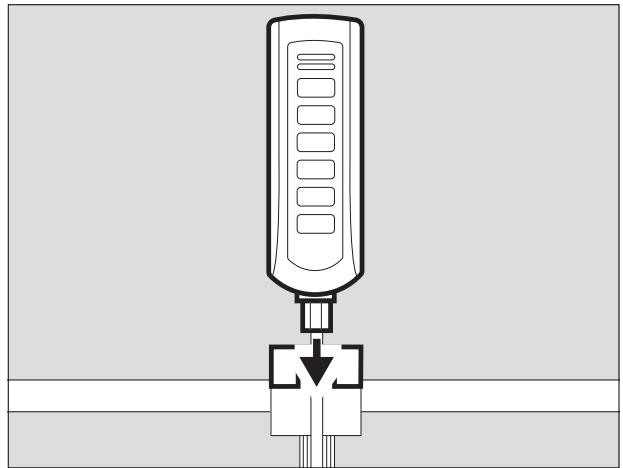
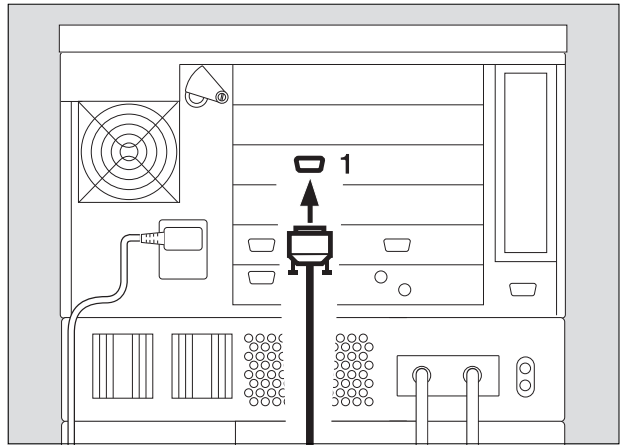

Note automatic self-test

- when connecting the Remote Pad while EvitaXL is switched on

or

- when switching EvitaXL on after connecting the Remote Pad.

- Do not press any keys on the Remote Pad.
- All LEDs on the Remote Pad light up for 5 seconds:
 - 2 red LED
 - 3 yellow LED
 - 4 yellow LEDs in the keys
- The Remote Pad is tested by EvitaXL. An advisory message is output if a fault is detected, see "Fault – Cause – Remedy", page 144.

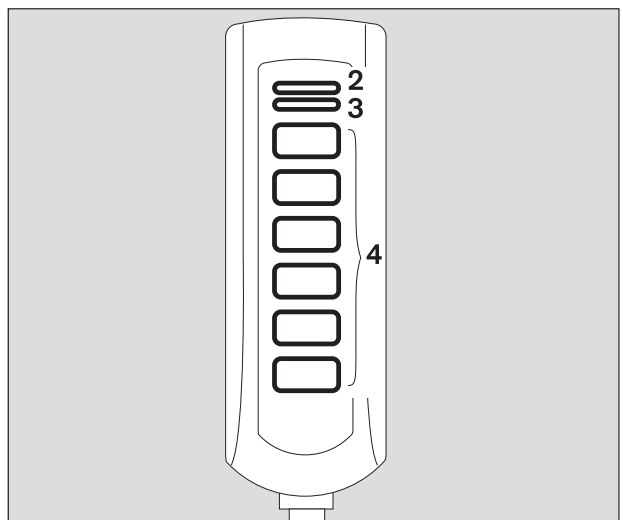

Connecting the nurse call (optional)

Socket on the rear of EvitaXL for connecting alarm signals to a central alarm station in the hospital.

- The kit may only be installed by specialists.
For details of the characteristics, refer to the technical data, page 197.
- The 6-pin round DIN plug (female connector) must be connected to the lead for the central alarm station in the hospital by a specialist.

Connection 3 to 5 makes and the nurse call is activated as soon as EvitaXL signals an alarm.

The central hospital alarm system may only be connected to the nurse call if EvitaXL is connected to the mains power supply via a mains power cable or if it has been earthed via the earth connection on the back of EvitaXL. Electric power may pose a hazard in all other cases.

- 1 Plug the connector into the »  « socket on the rear and screw into place.

Only alarm messages of the highest priority (see page 80) are transmitted via nurse call.

Alarm messages are displayed in the top line of the screen in red and with three exclamation marks, see page 80.

Caution and advisory messages are not transmitted.

The nurse call is also activated when the internal acoustic generator in the ventilator is defective.

- Check correct operation of connected nurse call system.

Connection of a nurse call does not relieve staff of their duty to check the monitoring on the EvitaXL screen at regular intervals.

- Screen displays must be checked regularly.

A fault in any of the components in the link between nurse call and central hospital alarm system (e.g. in the electronics for nurse call in EvitaXL, in the EvitaXL power supply or in the alarm generator of the central hospital alarm system, etc.) may result in failure of the nurse call.

The hospital connections to the central alarm typically use only one channel. The electronics for nurse call consequently also uses only one channel.

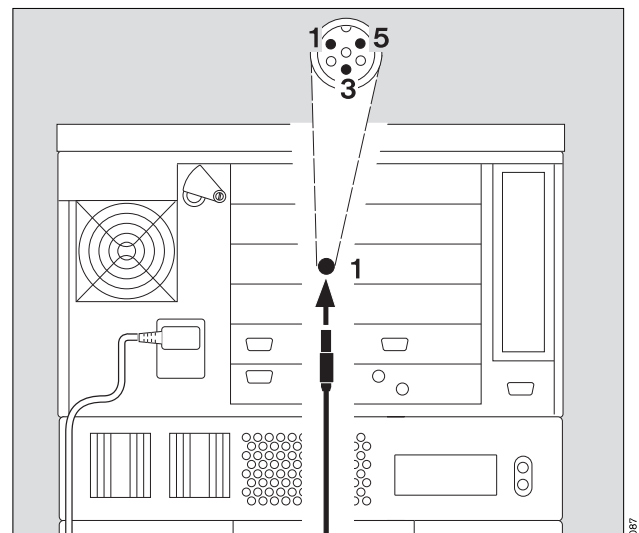

Device Check

Must be carried out immediately before use on the patient in order to confirm that the ventilator is operating correctly.

The following functions are performed during this device check:

- Checking that the machine assembly is complete
- Testing the alarm tone
- Testing the expiratory valve
- Testing of the air-O₂ changeover valve
- Testing the safety valve
- Calibration of the flow sensor
- Calibration of the O₂ sensor
- Calibration of the CO₂ sensor
- Testing the leakproofing of the hose system
- Determination of the compliance and resistance of the hose system

The test results obtained from this device check and the calibration and zero-checking values of the sensors remain stored until the next calibration – even if the device is switched off.

If the hose system, type of humidification or patient mode is changed after performing the device check, the leak test must be repeated before starting operation.

Preparing the adult test lung 84 03 201

for the adult hose system

The test lung consists of an elbow connector for connection to the Y-piece, a 7 mm diameter catheter connection for simulating the resistance of the airways and a 2 L breathing bag to simulate compliance.

- **Overextended breathing bags or test lungs with low compliance must not be used as they may cause artefacts during the device check!**
- The elbow connector must not be plugged into the patient connection of the Y-piece until requested by EvitaXL.

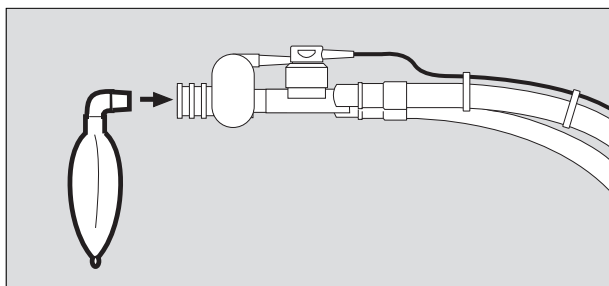

094

Preparing the child test lung 84 09 742

for the paediatric hose set

The test lung consists of a tracheal tube CH 12 to simulate the resistance of the airways and a small bellows to simulate compliance.

- The elbow connector must not be plugged into the patient connection of the Y-piece until requested by EvitaXL.

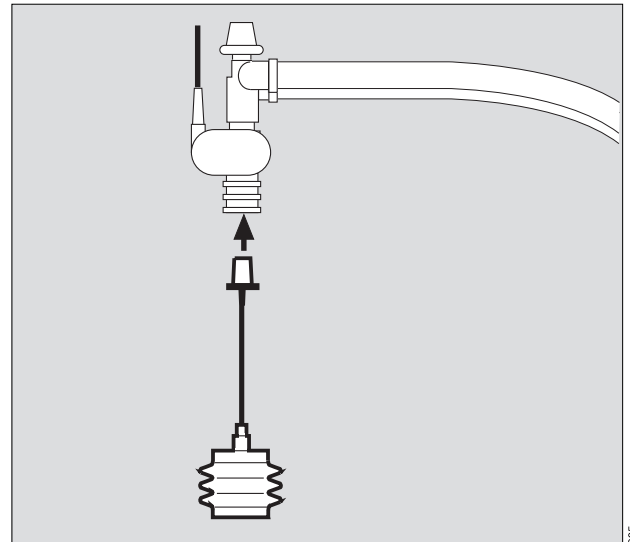

- Switch on unit = pivot flap* upwards and press power switch until it clicks into position. The flap falls over the button to protect against inadvertent switching off.

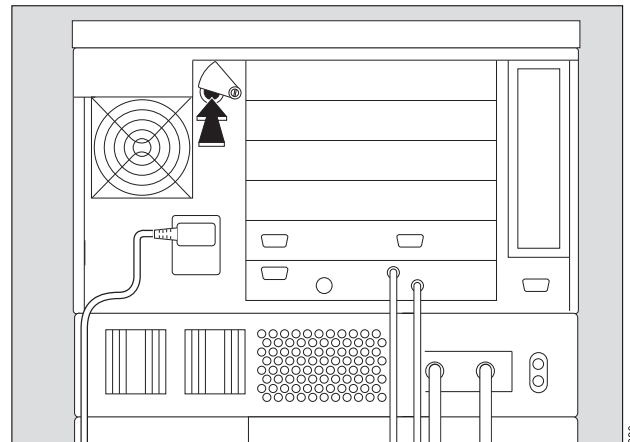

* Flaps may differ, depending on the power supply used, see "Switching on", page 45.

The self-test screen with version No., date and part No. of the software used is displayed on the screen.

The self-test is performed automatically.

- Wait for the test phase to be completed.

The bargraph on EvitaXL indicates the time elapsed for the self-test. The start screen is then displayed.

- EvitaXL starts ventilation with the pre-configured settings unless values are changed or standby mode is activated within 30 seconds.

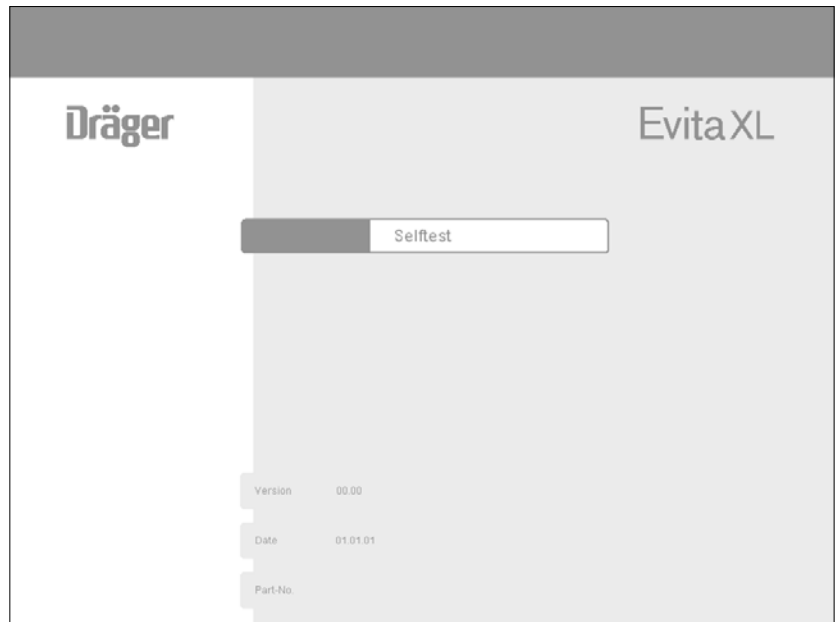

On the start screen (example):

- Touch the screen key »Standby« within 30 seconds and confirm = press the rotary knob.

The line for alarm messages reads:
Standby activated !!!

To reset this message:

- Touch the screen key »Alarm Reset« after the message, confirm = press the rotary knob.



- Touch the screen key »Check«.

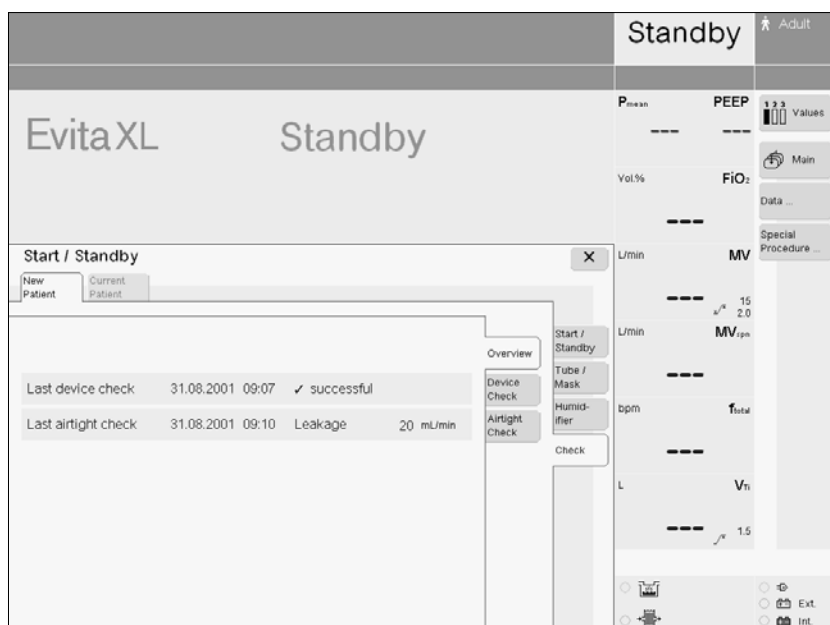

- Touch the screen key »Device Check«: EvitaXL displays the date of the last device check and a list of the individual checks. The scope of this list depends on the options available.

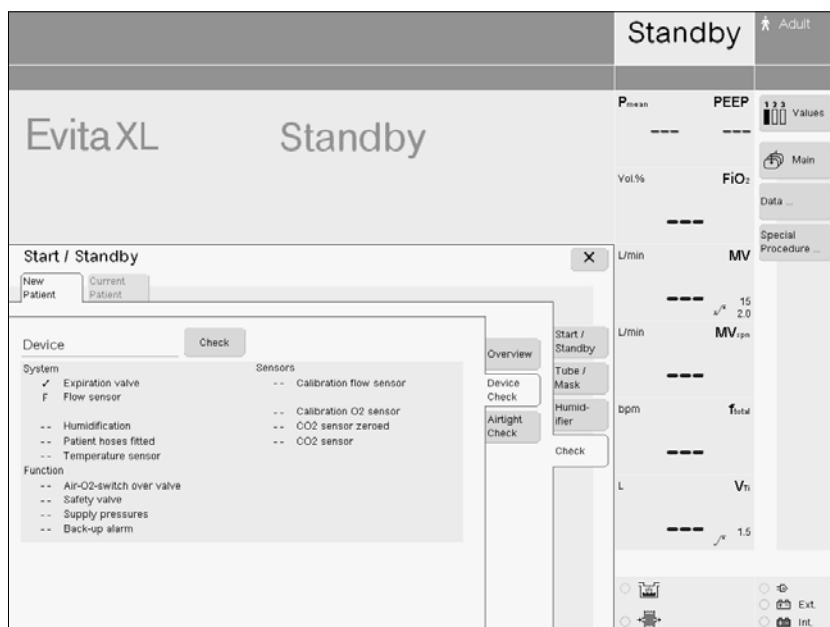

A device check cannot be performed during automatic calibration of the flow sensor or O₂ sensor:

- Wait until calibration is complete and start the device check again.

The following tests are performed during the device check:

System

- Seating and clear passage of the expiratory valve
- Seating of the flow sensor
- Seating of the neonate flow sensor (if "NeoFlow" option is installed)
- Type of humidifier
- Completeness of hose system
- Seating of the temperature sensor

Function

- Function of the air-O₂ changeover valve
- Function of the safety valve
- Gas supply
- Function of the auxiliary alarm and power failure alarm

Sensors

- Calibration of the flow sensor
- Calibration of the neonate flow sensor (if "NeoFlow" option is installed)
- Calibration of the O₂ sensor
- Zero alignment of the CO₂ sensor
- Calibration of the CO₂ sensor

- Hose system leak test

The user is guided through each check in a dialogue with EvitaXL. Questions are displayed in the information line below the Alarms field and must be answered by touching the screen key »Yes« or »No«. Instructions for carrying out the check may also be displayed instead.

A correct result is indicated by the ventilator with a tick (✓). Faulty results are marked F. Two dashes (– –) appear if a check is not performed.

If faulty results are obtained (F):

- Remedy the cause of the fault
and
- Touch the screen key »Repeat«.

Checks may also be skipped by touching the screen key »next test« if this is acceptable.

To start the device check:

- Touch the screen key »Check« in the checklist.

The ventilator carries out each check, line by line.

The results obtained in this device check and the calibration values for the sensors are saved until the next calibration run, even when the ventilator is switched off.

After the device check:

- Perform a leak test, see page 39.

Leak test

This test must be performed:

- after the device check,
- after changing the hose system,
- after changing the humidifier.

In the checklist:

- Touch the screen key »Airtight Check«.

The result of the last leak test is displayed together with the following values:

- Leakage
- Compliance
- Insp. Resistance
- Exp. Resistance

To start the leak test:

- Touch the screen key »Check«.

The actual leakage flow is displayed continuously throughout the test. A leakage flow of 300 mL/min at a pressure of 60 mbar is permissible.

After the leak test, the ventilator determines the compliance and the inspiratory and expiratory resistance of the hose system.

The established compliance of the hose system is used by the ventilator for automatic correction of the volume-controlled ventilation strokes, as well as of the measured values for flow monitoring, see page 218.

When changing the patient mode or type of humidifier, the ventilator automatically resets the values for hose compliance and hose resistance to the default values.

To return to the start screen:

- Touch the screen key »Start/Standby« in the »Start/Standby« menu.

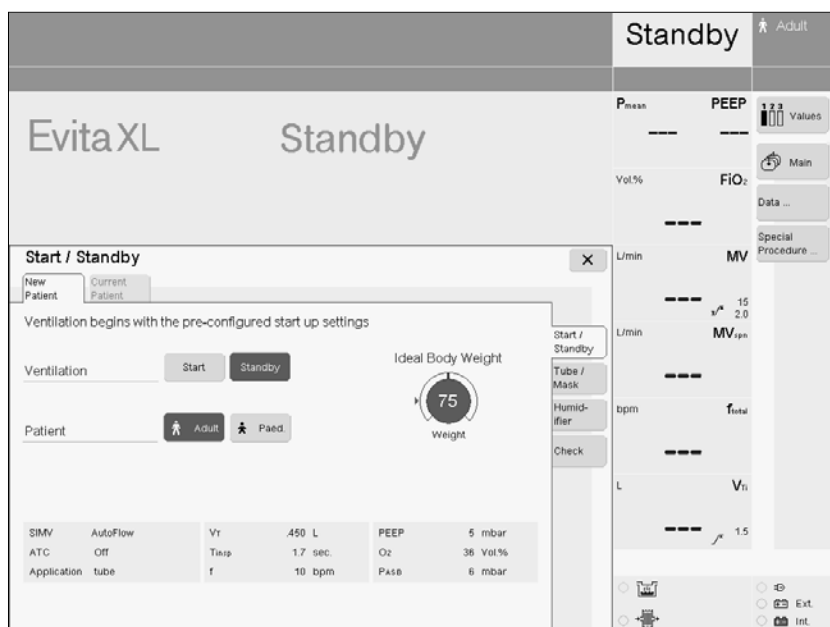
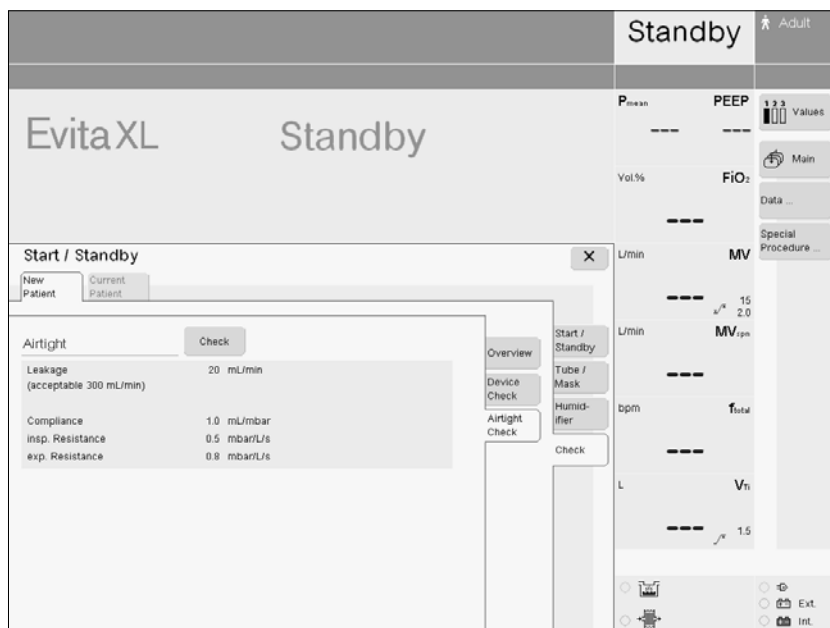

Preparing for use



Entering the humidifier type

Application mode Tube/Mask (optional)

Entering the humidifier type

In standby mode:

- Touch the screen key »Humidifier«. The menu for entering the humidifier used is now displayed:

 Active Humid. =
Breathing gas humidifier
 HME/Filter =
Heat moisture exchanger

- Touch the screen key corresponding to the type of humidifier used. The key turns yellow.

- Confirm = press the rotary knob, the key turns green.

The selected humidifier is included in the compliance calculation by EvitaXL.

The yellow LED in front of the symbol for the selected humidifier lights up in the status field.

 Active humidifier

 HME/Filter

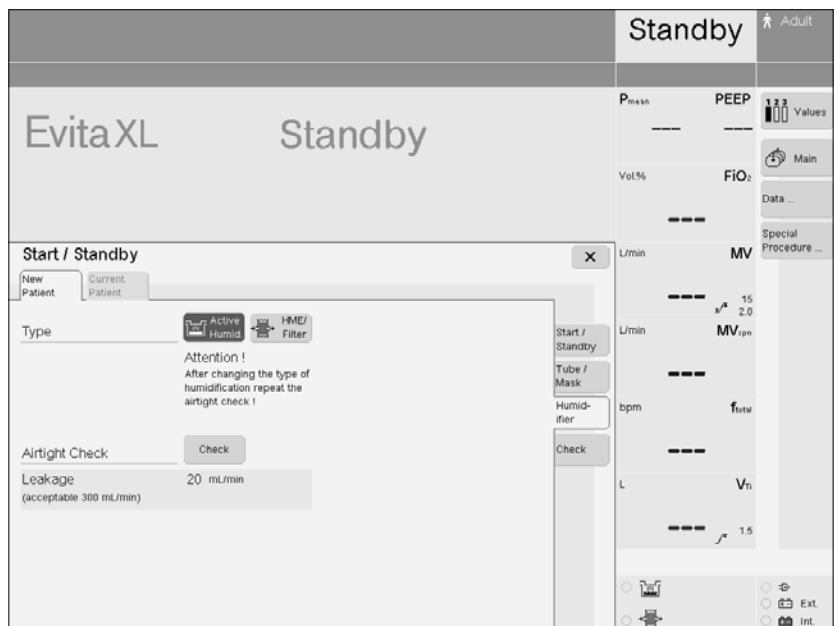

After changing the humidifier:

- Perform a leak test, page 39.

Application mode Tube/Mask (optional)

In standby mode:

- Touch the screen key »Tube/Mask«. The menu for selecting tube or mask is displayed (NIV – non-invasive ventilation).

- Touch the corresponding screen key; it turns yellow.

- Confirm = press the rotary knob, the key turns green.

The corresponding application mode is now active.

If » Mask (NIV)« has been selected:

 = Mask Ventilation is displayed.

For details on using NIV, see page 76.

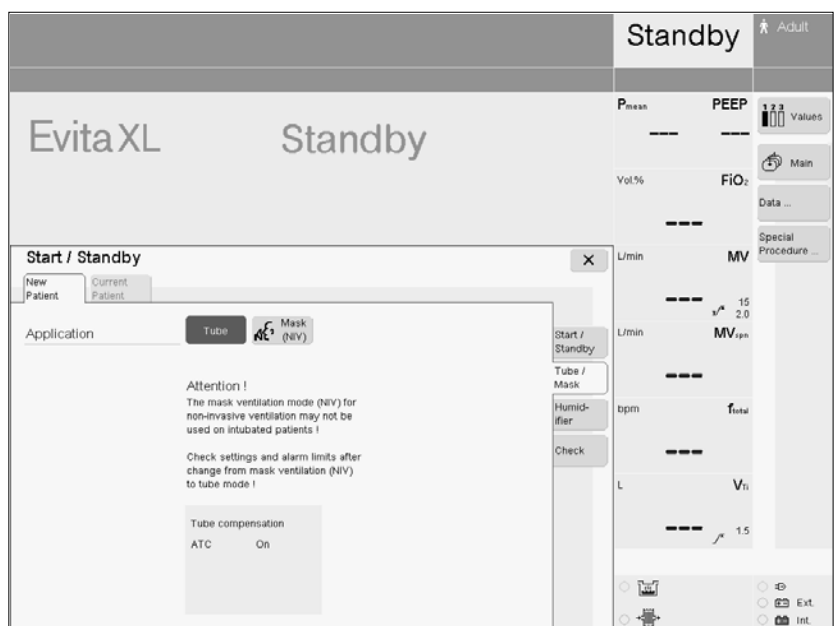

Ventilation while transferring a patient within the hospital

To ensure that EvitaXL cannot topple over, EvitaXL must not be tilted more than 5°!

EvitaXL must not be placed on the bed while transferring a patient.

EvitaXL must be secured so it cannot topple over/fall down.

To ensure that the equipment cannot topple over, the accessories must be moved to the most advantageous position:

- Hinged arm set to minimum deflection.
- Drawers pushed in fully.
- Hoses and cables hooked as close as possible to the trolley.
- Humidifier secured to the trolley, not to EvitaXL itself.

Operation

Starting up	45
Switching on	45
Setting new ventilation parameters	47
Setting Ventilation Modes	48
IPPV	49
SIMV, SIMV/ASB	50
MMV, MMV/ASB	52
ILV	53
BIPAP, BIPAP/ASB	59
BIPAP _{Assist}	61
APRV	62
CPAP-ASB	63
PPS (optional)	64
Setting special functions	66
Flowtrigger	68
Apnoea Ventilation	69
AutoFlow	71
ATC	72
Sigh	74
PLV	75
NIV mask ventilation (optional)	76
Using NIV	76
Selecting application mode »Mask«	77
Setting ventilation parameters for NIV	77
Monitoring in »Mask« mode	78
Leakage compensation in »Mask« mode	78
Setting alarm limits	79
In the event of an alarm	80
Suppress alarm tone	82
Power failure alarm	82

Displaying graphics	83
Freeze	85
Loop display	85
Display 1 hr trend	87
Display measured values	88
Display all measured values and settings	88
Display logbook	89
Display trends (1 to 24 hr)	90
Additional functions	91
Medicament nebulisation	91
Oxygen enrichment for bronchial suction	94
Manual inspiration	96
Expiration Hold	97
Diagnostic functions	98
Occlusion pressure P 0.1	98
Intrinsic PEEP – PEEPi	100
Negative Inspiratory Force NIF	101
Low Flow PV-Loop (optional)	102
Sensors	106
Flow sensor calibration	106
External flow compensation	107
O ₂ sensor calibration	109
Zero/check/calibrate CO ₂ sensor	110
Switching off the monitor functions	118
Selecting Standby Mode	119
Terminating Standby Mode	120
O₂ Therapy (optional)	121
O ₂ Therapy preparation	121
Switching on O ₂ Therapy	123
Switching off O ₂ Therapy	123

Starting up

Switching on

- Switch on unit = press power switch until it engages.
The flap falls over the button to protect against inadvertent switching off.
To switch off, pivot the flap upwards and press the button in fully.

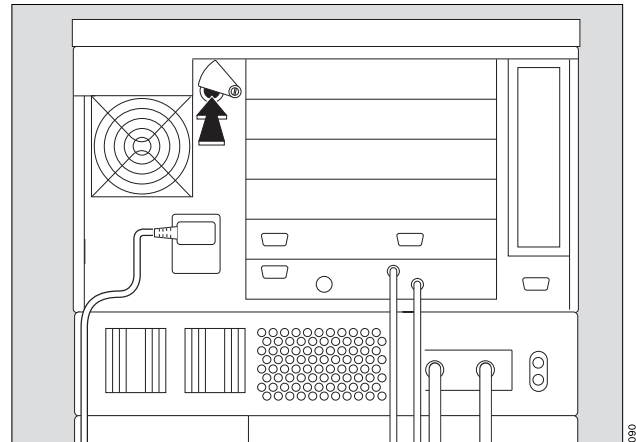

Units with DC power supply MB:

- Switch on unit = pivot flap upwards and press power switch until it engages.
The flap falls over the button to protect against inadvertent switching off.
To switch off, pivot the flap upwards and press the button in fully.

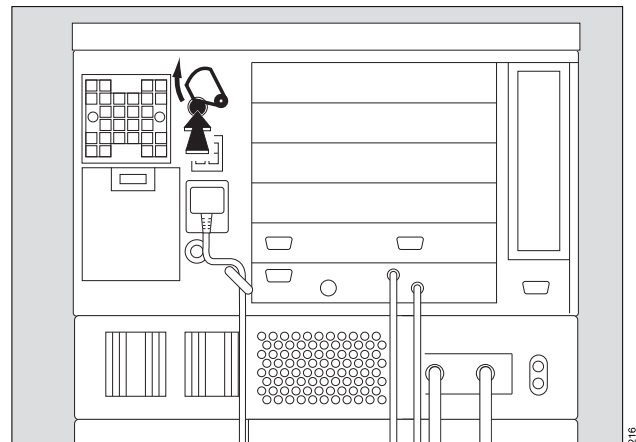

The self-test screen is displayed. The self-test is performed automatically.

- Wait for the test phase to be completed.
The bargraph indicates the time elapsed for the self-test.

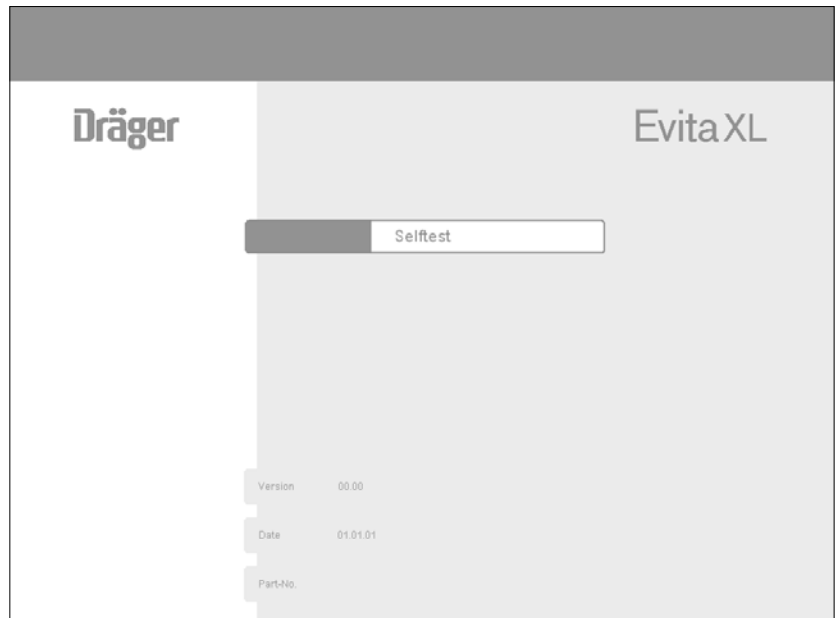

The Start screen is then displayed.
(Example: Previous Patient)

The last settings configured for the patient, including alarm limits, application status and equipment status, can be restored with EvitaXL. Monitoring is always active after switching on.

To restore the previous settings:

- Touch the screen key »Previous Patient«, confirm = press rotary knob.

The previous ventilation settings are now effective again.

The key »Previous Patient« is not displayed by EvitaXL or cannot be selected following a loss of data or removal of a previously used option, thus preventing restoration of the previous setting. Restoration of the previous setting is similarly prevented by EvitaXL if it was configured in such a way before switching off that the former patient mode is no longer available.



Setting new ventilation parameters

The patient mode can be selected in two ways with EvitaXL:

- Select »**Adult**« or »**Paed.**«,
- Set an ideal body weight.

These two possibilities can be configured, see "Configuration", page 125.

EvitaXL is configured by the manufacturer for selection of an ideal body weight.

The further procedure is described with the configuration.



Depending on the required patient mode, touch either:

- the screen key »**Adult**« or »**Paed.**«
- Touch the screen knob »**Ideal Body Weight**«.
- Enter the ideal body weight [kg] = turn rotary knob, confirm = press rotary knob.

EvitaXL determines the tidal volume VT and ventilation frequency f on the basis of the ideal body weight and displays these values in the lower part of the menu.

The other ventilation parameters displayed in the lower part of the menu are initial values.

They are effective when the ventilator is switched on and when a new ventilation mode is selected (New Patient).



Start ventilation

- Touch the screen key »**Start**«, confirm = press rotary knob.
The ventilator starts with these initial values.
- Check the settings.

To set ventilation parameters

- Press the key »  **Ventilator Settings**«.
- Touch the ventilation parameters in the menu »**Ventilator Settings**«, set = turn rotary knob, confirm = press rotary knob.

Arrows (▶) beside the scales on the screen knobs in the menu »**Ventilator Settings**« indicate the initial values. These initial values can be configured as required, see "Configuration", page 125.

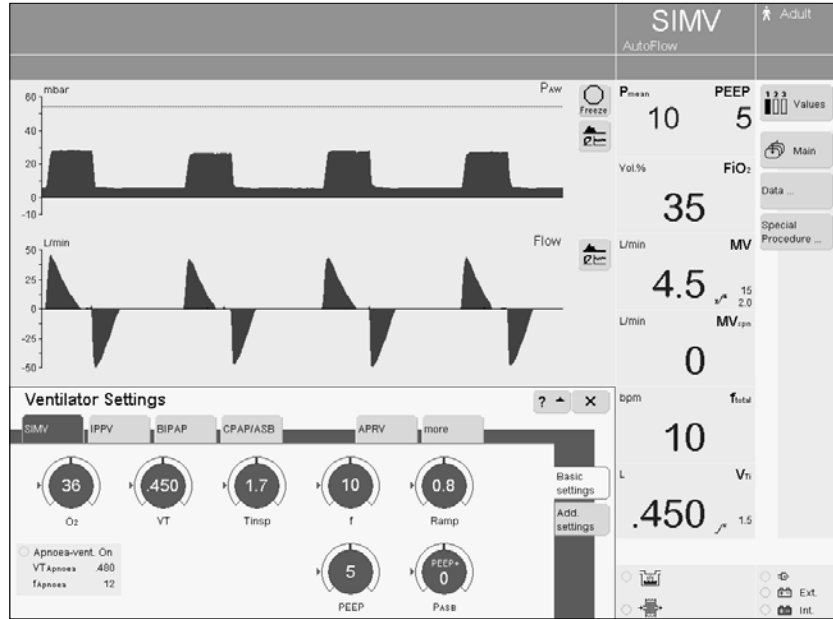

Setting Ventilation Modes

The following ventilation modes are configured by the manufacturer:

- SIMV
- IPPV
- BIPAP
- CPAP-ASB

Other ventilation modes can be selected via the screen key »**more**«:

- MMV
- BIPAP_{Assist}
- APRV
- PPS (optional)

The ventilation modes can also be supplemented, see "Setting special functions", page 66.

IPPV

Intermittent Positive Pressure Ventilation
Volume-controlled ventilation with fixed, mandatory minute volume MV, set with tidal volume VT and frequency f.

Set the pattern of ventilation for IPPV with the ventilation parameters:

Tidal volume »VT«

Insp. Flow »Flow«

Frequency »f«

Inspiration time »T_{insp}«

O₂ concentration »O₂«

Positive end-expiratory pressure »PEEP«

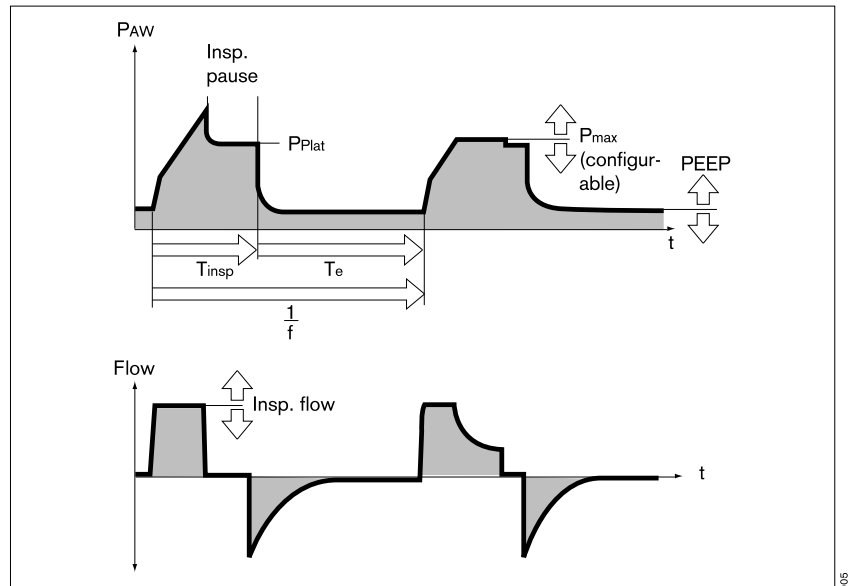

To set:

- Touch the appropriate screen knob.
- Adjust to the desired value = turn rotary knob.
- Confirm setting = press rotary knob.

To view additional text information on IPPV:

- Touch the screen key »? ▲«,

IPPV can be supplemented to include the following special functions:

- Flowtrigger, page 68.
- AutoFlow[®], page 71.
- ATC, page 72.
- Sigh, page 74.
- PLV, page 75.

These functions can be enabled in »Add. settings«.

Setting alarm limits, see page 79.

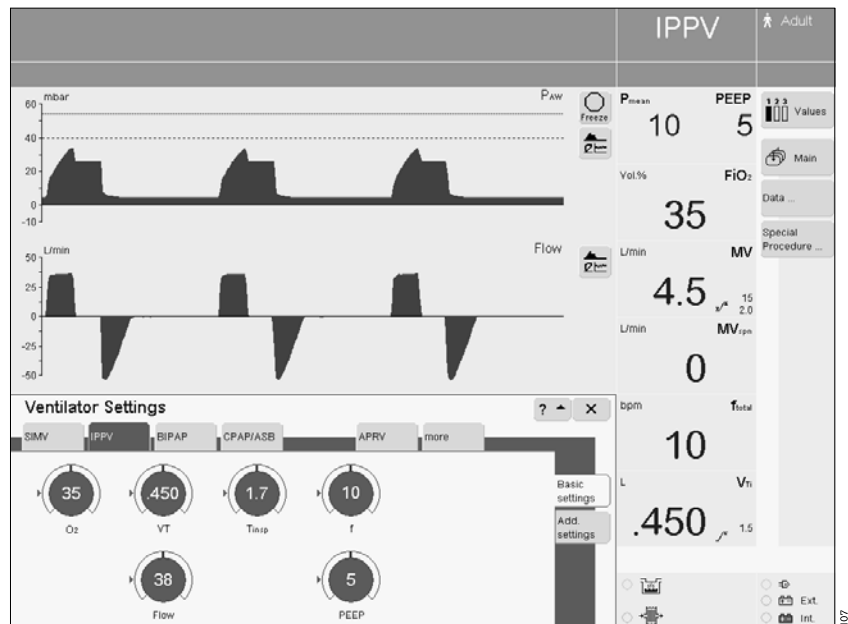

SIMV, SIMV/ASB

Synchronized Intermittent Mandatory Ventilation*

Assisted Spontaneous Breathing**

Combines mechanical (volume-controlled) ventilation with spontaneous breathing. The patient can breathe spontaneously between the mandatory ventilation strokes, contributing to the total minute volume. The spontaneous breaths can be supported with ASB. Mandatory ventilation strokes ensure a minimum level of ventilation in the times in between. This minimum ventilation is determined via the two set parameters tidal volume »VT« and frequency »f« and is the product of VT x f.

The frequency can be reduced to zero during the weaning process. The device automatically changes to the ventilation mode CPAP or CPAP/ASB. This ventilation mode is also indicated on the screen. The screen key »SIMV« and the screen knobs for setting the SIMV parameters remain on display.

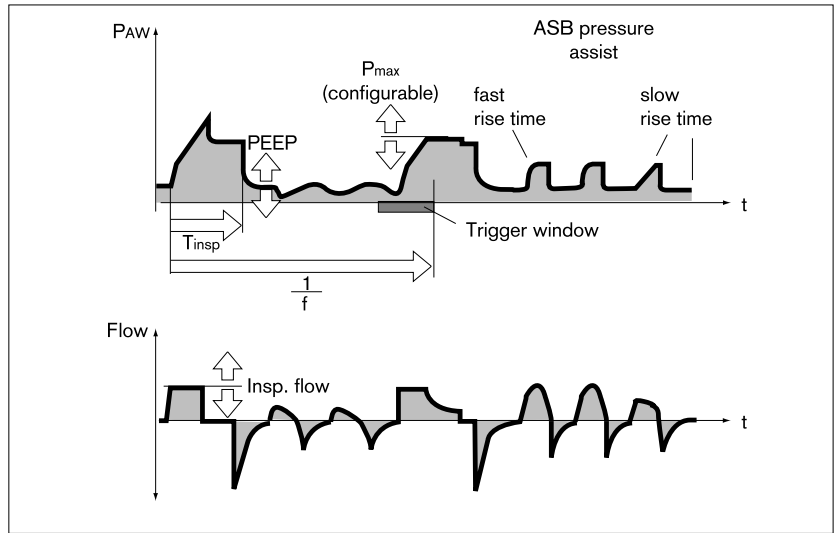

Set the pattern of ventilation for SIMV and SIMV/ASB with the ventilation parameters:

Tidal volume »VT«

Insp. Flow »Flow«

Frequency »f«

Inspiration time »T_{insp}«

O₂ concentration »O₂«

Positive end-expiratory pressure »PEEP«

Pressure support »PASB«

Pressure rise time »Ramp«

To set:

- Touch the appropriate screen knob.
- Adjust to the desired value = turn rotary knob.
- Confirm setting = press rotary knob.

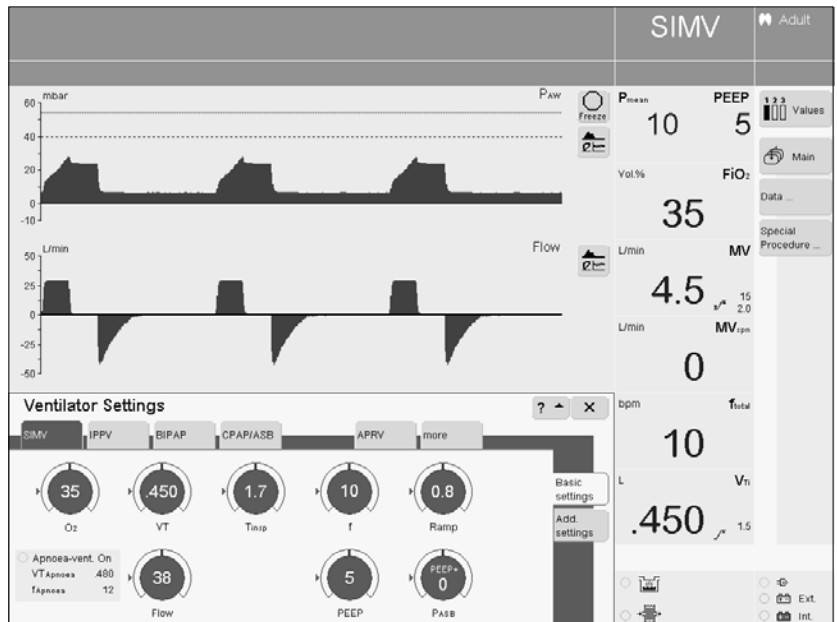

* For a detailed description of SIMV, please refer to page 211.

** For a detailed description of ASB, please refer to page 216.

To view additional text information on
SIMV, SIMV/ASB:

- Touch the screen key »? ▲«.

SIMV, SIMV/ASB can be supplemented
to include the following special
functions:

- Flowtrigger, page 68.
- Apnoea Ventilation, page 69.
- AutoFlow[®], page 71.
- ATC, page 72.
- PLV, page 75.

These functions can be enabled in »Add.
settings«.

Setting alarm limits, see page 79.

MMV, MMV/ASB

Mandatory Minute Volume Ventilation* Assisted Spontaneous Breathing

The overall minute volume is preset to a mandatory level, which can be adjusted by means of the tidal volume V_T and frequency f .

The patient can breathe spontaneously, thereby contributing a portion of the overall minute volume.

The difference between the spontaneously breathed minute volume and the set minute volume is covered by the mandatory ventilation strokes. Spontaneous breathing can be assisted with additional pressure by ASB.

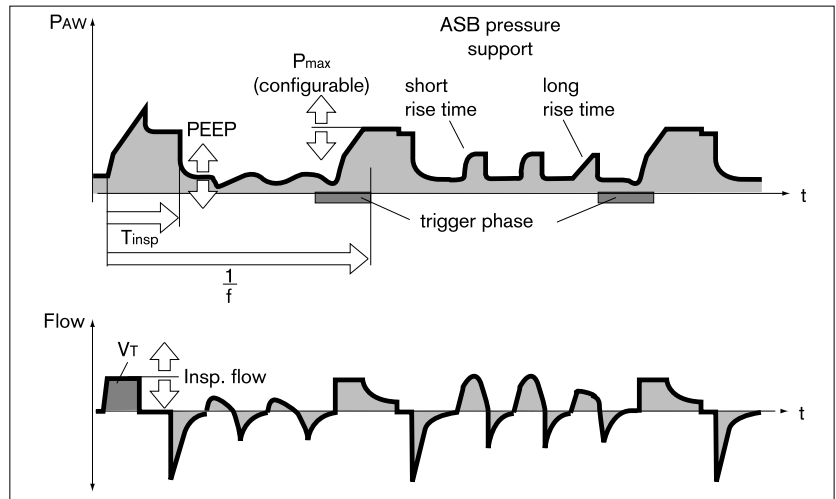

Set the pattern of ventilation for MMV and MMV/ASB with the ventilation parameters:

Tidal volume »**VT**«

Insp. Flow »**Flow**«

Frequency »**f**«

Inspiration time »**T_{insp}**«

O₂ concentration »**O₂**«

Positive end-expiratory pressure »**PEEP**«

Pressure support »**PASB**«

Pressure rise time »**Ramp**«

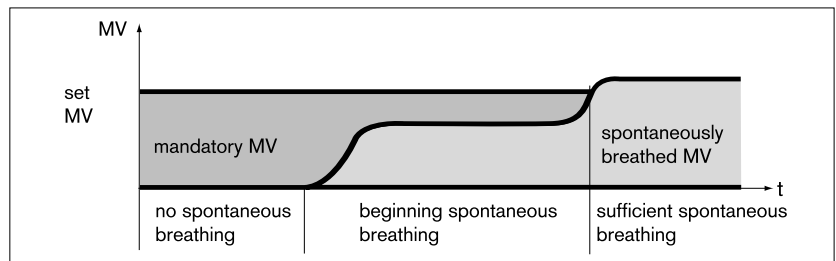

To set:

- Touch the appropriate screen knob.
- Adjust to the desired value = turn rotary knob.
- Confirm setting = press rotary knob.

To view additional text information on MMV, MMV/ASB:

- Touch the screen key »? ▲«.

MMV, MMV/ASB can be supplemented to include the following special functions:

- Flowtrigger, page 68.
- AutoFlow[®], page 71.
- ATC, page 72.
- PLV, page 75.

These functions can be enabled in »Add settings«.

Setting alarm limits, see page 79.

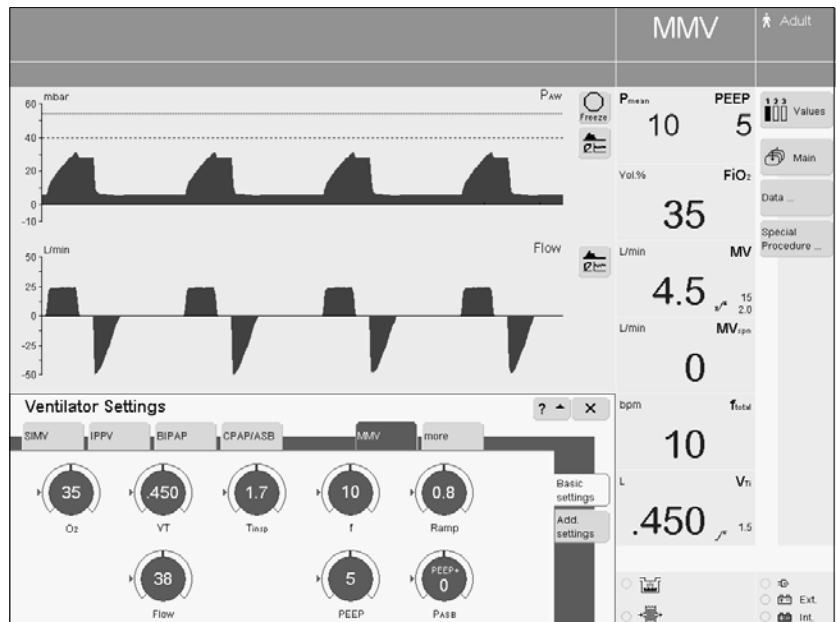

* For a detailed description of MMV, please refer to page 212.

ILV

ILV = Independent Lung Ventilation

Separate, differentiated, synchronised ventilation with two Evita units, to ventilate the lung independently from each other. The two Evita units are connected by analogue interfaces.

The two devices operate together in master/slave mode. The master device controls the operation.

Preparation

If a protective cap is fitted:

- Remove cap from ILV connection.

The following device combinations are possible:

- EvitaXL with EvitaXL
- EvitaXL with Evita 4
- EvitaXL with Evita 2 dura
- EvitaXL with Evita 2
- EvitaXL with Evita.

Requirements for combinations:

- Evita 2 and Evita have analogue Evita-Bus interfaces (optional).
- Connecting cable 84 11 794 must be used to connect EvitaXL to another EvitaXL or to an Evita 4 or an Evita 2 dura.
- Connecting cable 84 11 793 must be used to connect EvitaXL to an Evita 2 or an Evita.

The ILV cable should only be connected when EvitaXL is switched off!

For the combination:
EvitaXL with Evita 2 dura
and
EvitaXL with EvitaXL
and
EvitaXL with Evita 4:

- Connect the ILV ports of the two Evita units using connecting cable 84 11 794.

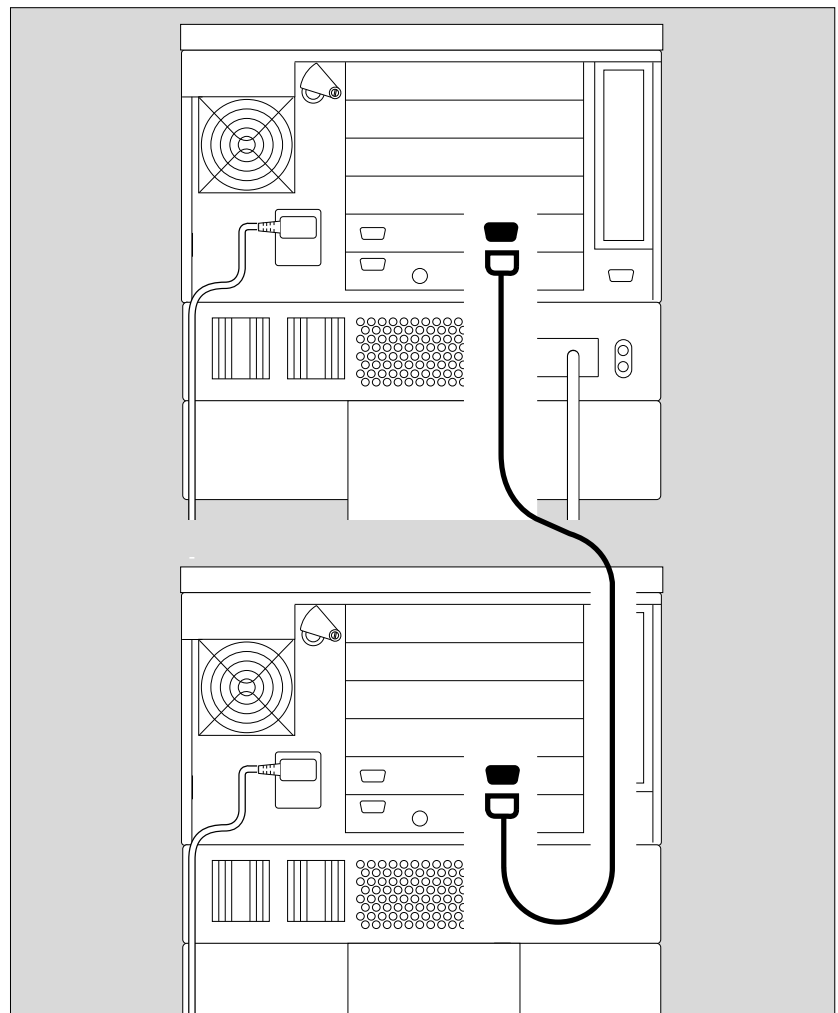

For the combination:

EvitaXL with Evita 2

and

EvitaXL with Evita:

- Connect both Evitas via the ILV port and the analogue interface using the connecting cable 84 11 793.

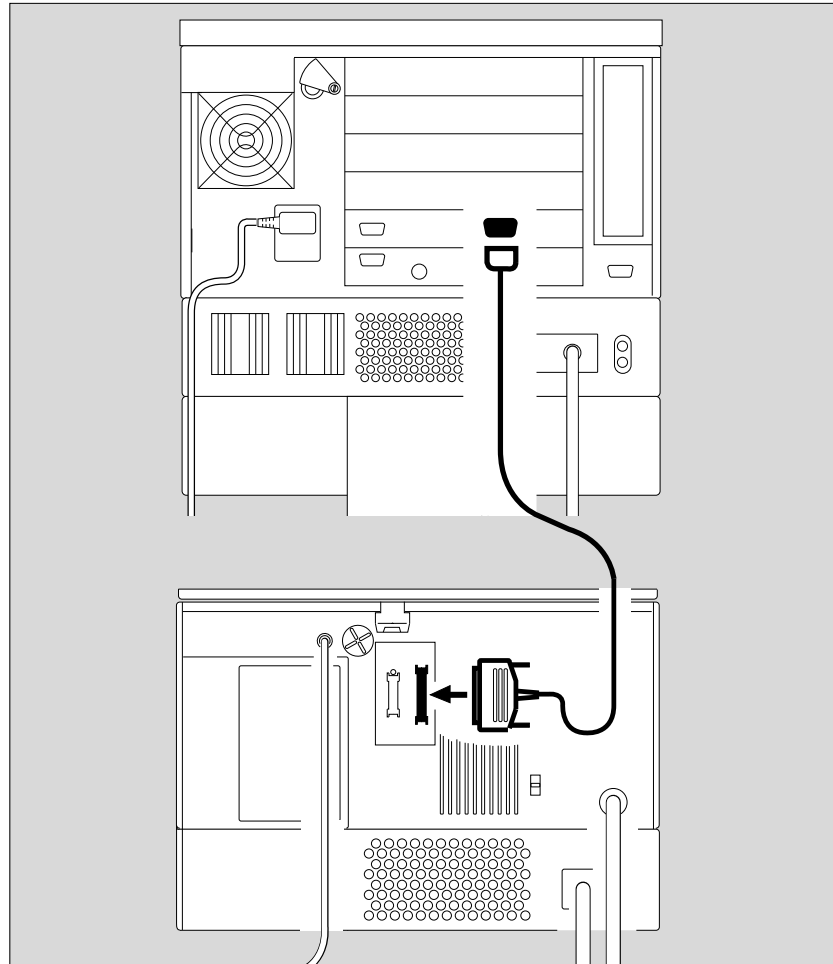

118

Setting the Master and Slave devices

To perform independent lung ventilation:

- Set up one device for ILV/Master mode and
- the other device for ILV/Slave mode.
- Set the parameters, see page 58.
- **Do not activate ILV mode until all the parameters for the ILV/Master and ILV/Slave are fully set.**

Setting ILV/Master

Volume-controlled ventilation with fixed, mandatory minute volume MV, set with tidal volume V_T and frequency f .

For independent lung ventilation of patients with no spontaneous breathing.

Set the ILV ventilation pattern with the parameters:

Tidal volume » V_T «

Insp. Flow »**Flow**«

Frequency » f «

Inspiration time » T_{insp} «

O₂ concentration »**O₂**«

Positive end-expiratory pressure »**PEEP**«

To set:

- Touch the appropriate screen knob.
- Adjust to the desired value = turn rotary knob.
- Confirm setting = press rotary knob.

ILV/Master can be supplemented to include the following special functions:

- Flowtrigger, page 68.
- ATC, page 72.
- Sigh, page 74.
- PLV, page 75.

These functions can be enabled in »Add. settings«.

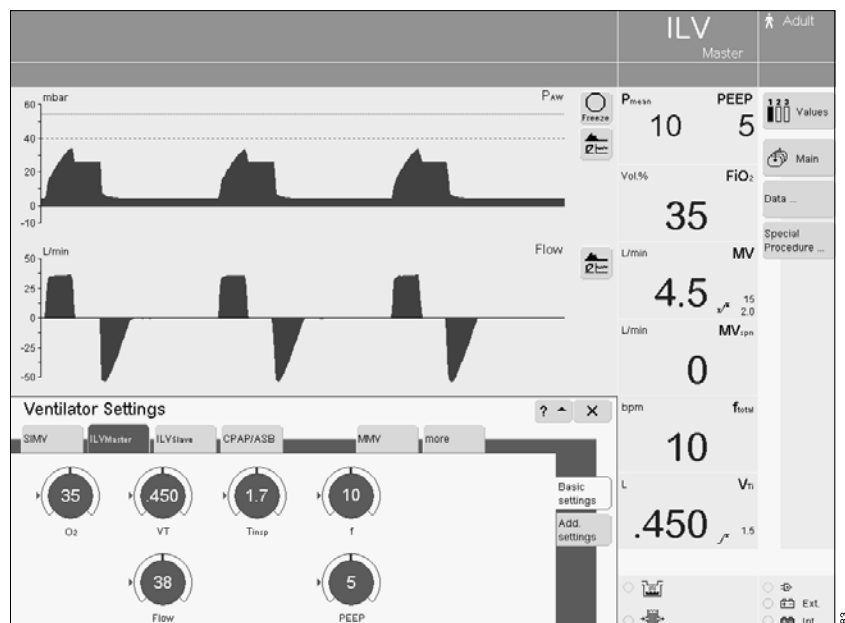
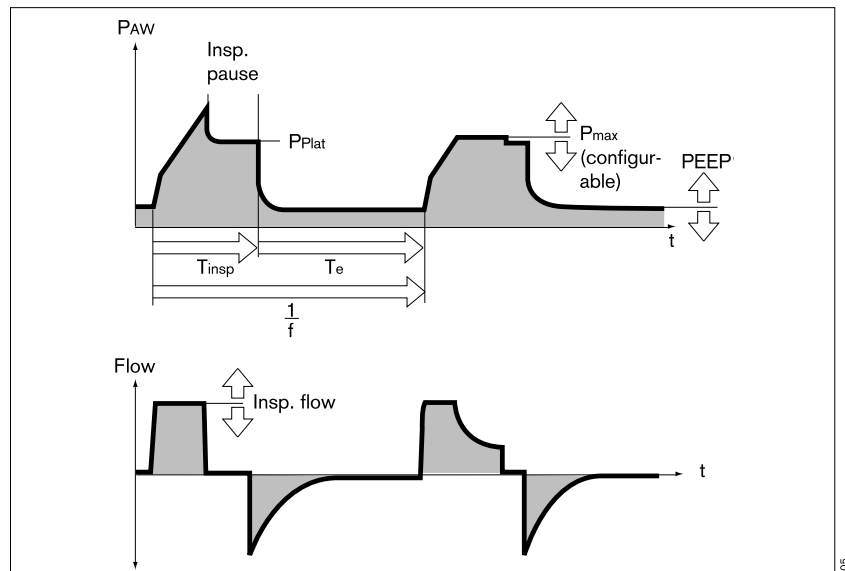

Setting ILV/Slave

Volume-controlled ventilation with fixed, mandatory minute volume MV, set with the tidal volume V_T and frequency f of the ILV Master device and selectable Slave mode.

For independent lung ventilation of patients with no spontaneous breathing.

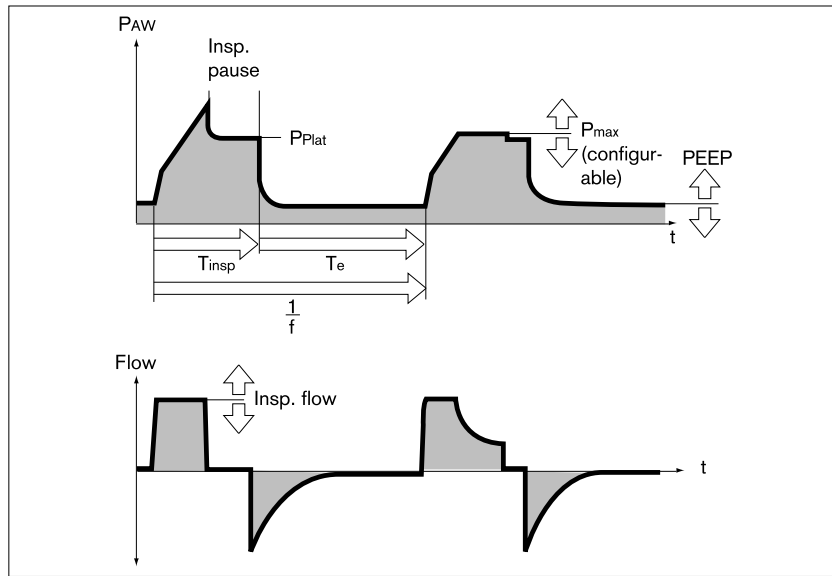

To set Slave mode:

- Touch the »Add. settings« screen key.
- Touch the »Slave Mode...« screen key.

To select the desired slave mode (e.g. »Asynchron«):

- Touch the appropriate screen key and press the rotary knob.

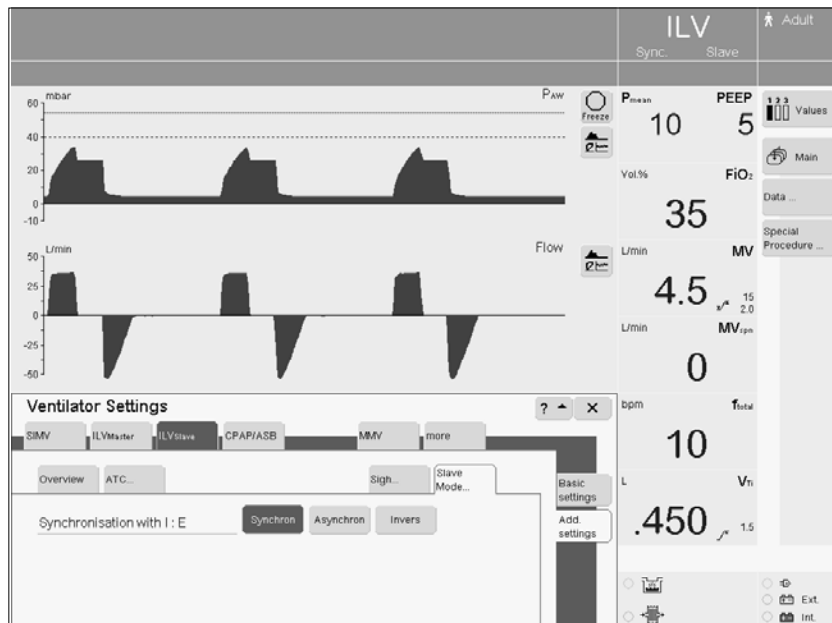

ILV: Master and Slave Synchronisation**Master device**

I:E ratio

Slave device:

Sync. – The I:E ratio of the slave device is determined by the I:E ratio of the master device. The start of inspiration is synchronised with the inspiration of the master device.

Slave device:

Async. – The start of inspiration is synchronised with the inspiration of the master device. The end of inspiration (incl. pause time) is determined by the »T_{insp}« setting. The I:E ratio of the slave device is freely selectable.

Slave device:

Inverse – The start of inspiration is synchronised with the start of expiration of the master device and vice versa. The I:E ratio of the slave device is the inverse of the I:E ratio of the master device.

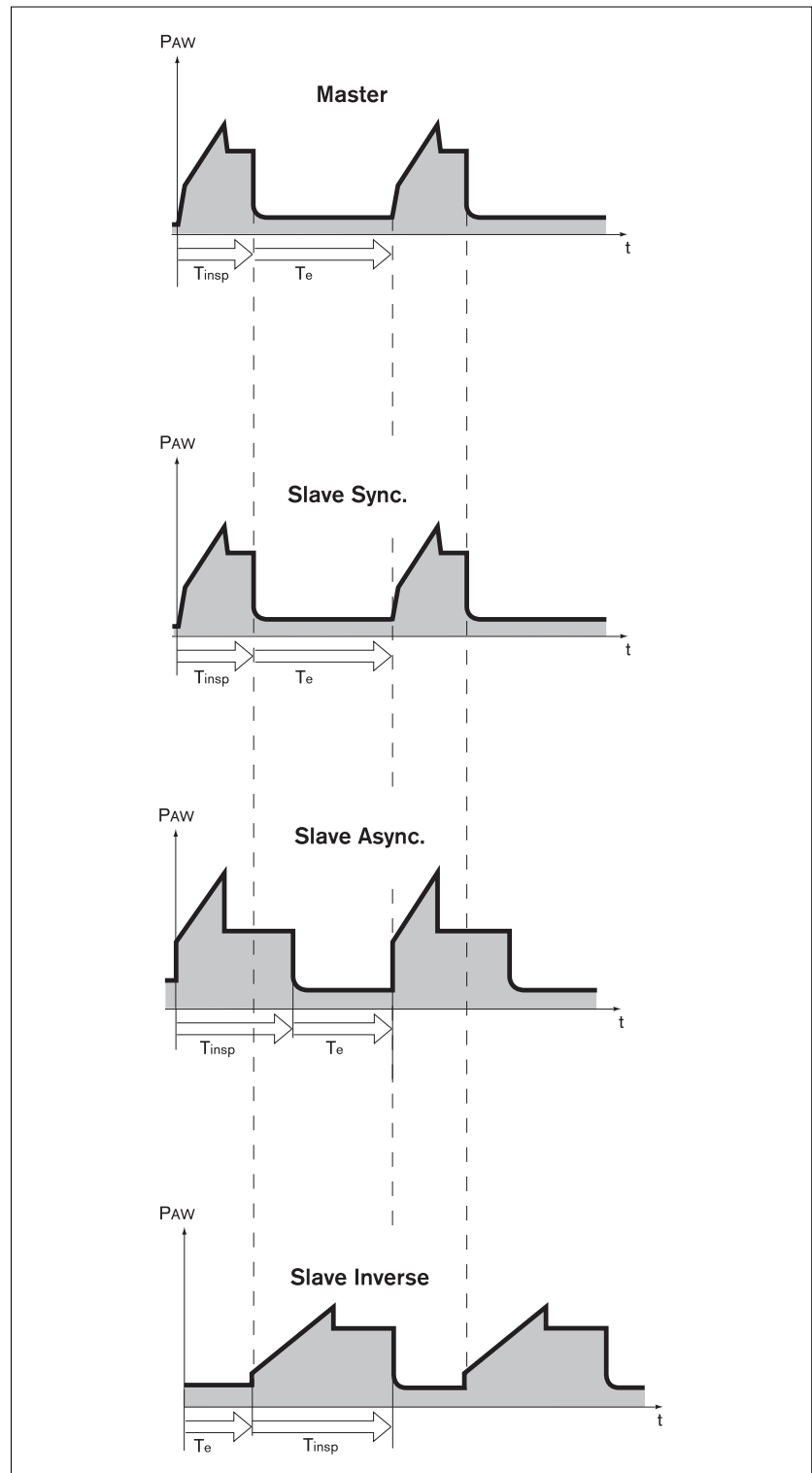

028

Set the ventilation pattern for ILV/ Slave with the following ventilation parameters:

- Tidal volume »VT«
- Insp. Flow »Flow«
- Frequency »f«
- Inspiration time »T_{insp}«
- O₂ concentration »O₂«
- Positive end-expiratory pressure »PEEP«

To set:

- Touch the appropriate screen knob.
- Adjust to the desired value = turn rotary knob.
- Confirm setting = press rotary knob.

The »f« setting is not immediately effective.

Nevertheless, to make sure that the two lung compartments are not ventilated with different frequencies in the event of inadvertent separation of the two devices:

»Set »f« on the slave device to the same value as on the master = safety setting.

In Async. slave mode, the »T_{insp}« setting is immediately effective. In "Synchronised" and "Inverse" modes, "T_{insp}" is only effective if the devices are inadvertently separated.

ILV/Slave can be supplemented to include the following special functions:

- Flowtrigger, page 68.
- ATC, page 72.
- Sigh, page 74.
- PLV, page 75.

These functions can be enabled in »Add. settings«.

To view additional text information on ILV:

- Touch the screen key »? ▲«.

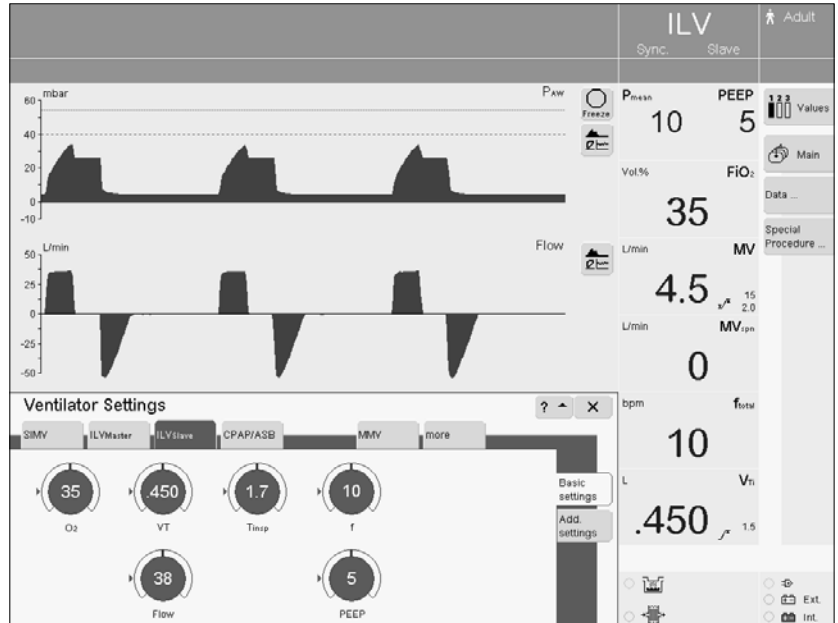

BIPAP, BIPAP/ASB

Biphasic Positive Airway Pressure*

Assisted Spontaneous Breathing

Pressure-controlled ventilation combined with free spontaneous breathing during the complete breathing cycle, and adjustable pressure support at CPAP level. The mandatory proportion of the total minute volume MV is set with inspiratory pressure P_{insp} above PEEP and Frequency f .

The frequency can be reduced to 0 during the weaning process. The device automatically changes to the ventilation mode CPAP or CPAP/ASB. This ventilation mode is also indicated on the screen. The screen key »BIPAP« and the screen knobs for setting the BIPAP parameters remain on display.

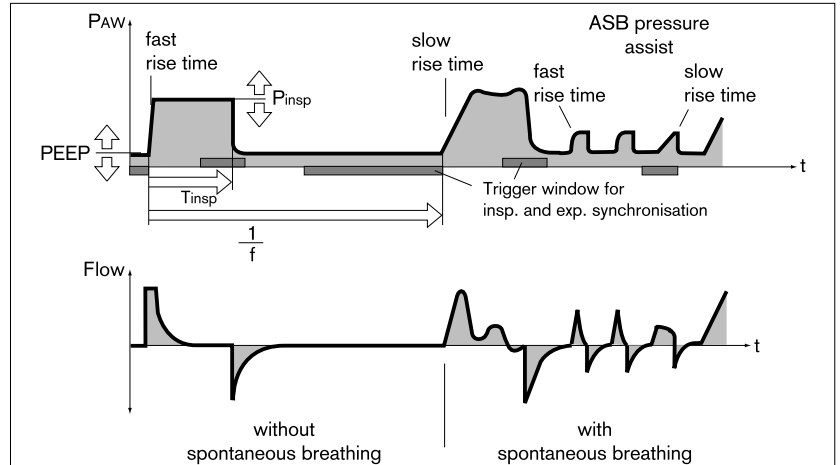

Set the pattern of ventilation for BIPAP and BIPAP/ASB with the ventilation parameters:

Inspiratory pressure » P_{insp} «

Frequency » f «

Inspiration time » T_{insp} «

O₂ concentration » O_2 «

Positive end-expiratory pressure »PEEP«

Pressure support » P_{ASB} «

Pressure rise time » $Ramp$ «

The inspiration pressure » P_{insp} « can be reduced to the PEEP level, in which case the ventilation pattern corresponds to CPAP or CPAP/ASB.

The inspiration pressure » P_{insp} « is set as an absolute value. Pressure support » P_{ASB} « is set relative to the PEEP level.

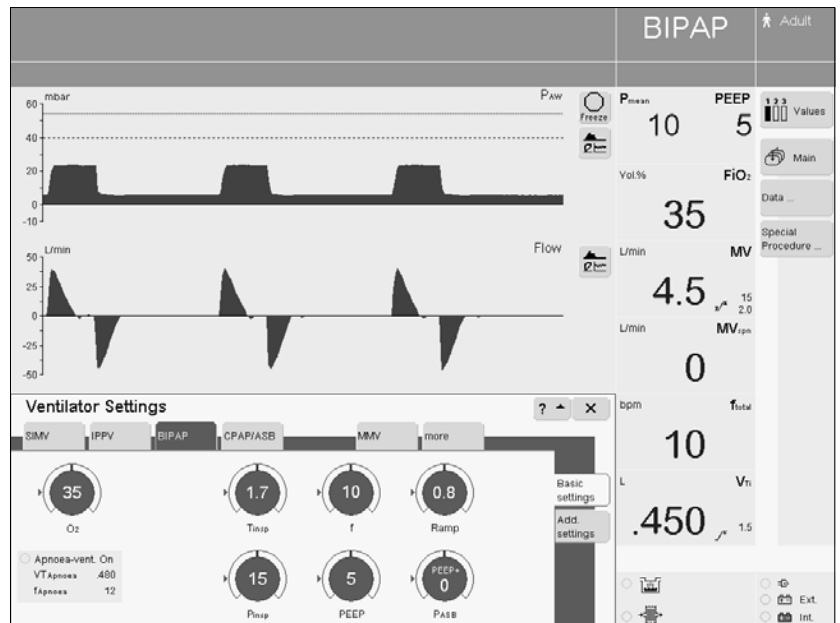

* For a detailed description of BIPAP, please refer to page 213.

To set:

- Touch the appropriate screen knob.
 - Adjust to the desired value
= turn rotary knob.
 - Confirm setting = press rotary knob.
-

To view additional text information on
BIPAP, BIPAP/ASB:

- Touch the screen key »? ▲«.

BIPAP, BIPAP/ASB can be supplemented to include the following special functions:

- Flowtrigger, page 68.
- Apnoea Ventilation, page 69.
- ATC, page 72.

These functions can be enabled in »Add settings«.

Setting alarm limits, see page 79.

BIPAPAssist

Biphasic Positive Airway Pressure Assisted*

Pressure-controlled, assisted ventilation

The inspiratory strokes are the same as for BIPAP, but the changeover from P_{insp} to PEEP is not synchronised with expiration by the patient. The patient can breathe spontaneously at PEEP level through the entire ventilation process.

Every spontaneous breathing activity by the patient triggers a synchronised inspiratory stroke.

A non-synchronised inspiratory stroke is started by the device at the latest upon expiry of the time $\frac{1}{f}$.

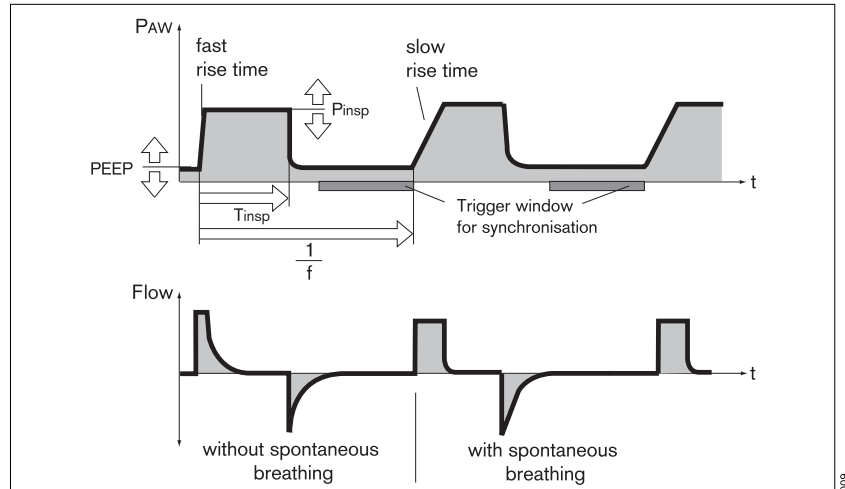

Set ventilation pattern for BIPAPAssist with the following parameters:

Inspiratory pressure » P_{insp} «

Frequency » f «

Inspiration time » T_{insp} «

O₂ concentration » O_2 «

Positive end-expiratory pressure »PEEP«

Pressure rise time »Ramp«

Flowtrigger »Flowtrig.«

The inspiratory pressure » P_{insp} « is set as an absolute value.

To set:

- Touch the appropriate screen knob.
- Adjust to the desired value = turn rotary knob.
- Confirm setting = press rotary knob.

To view additional text information on BIPAPAssist:

- Touch the screen key »?▲«.

BIPAPAssist can be supplemented to include the following special functions:

- Flowtrigger, page 68.
- ATC, page 72.

These functions can be enabled in »Add. settings«.

Setting alarm limits, see page 79.

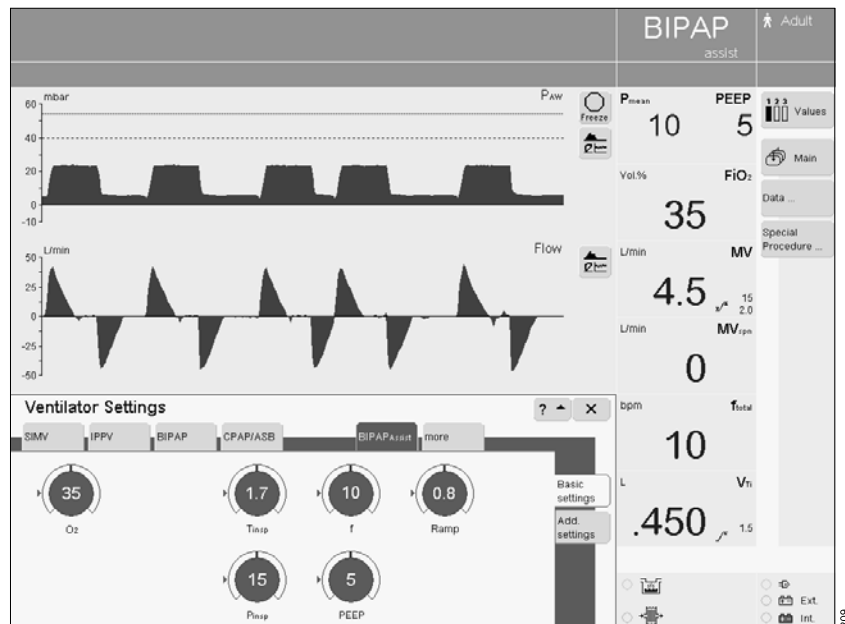

* For a detailed description of BIPAPAssist, please refer to page 215.

APRV

Airway Pressure Release Ventilation*

Free spontaneous breathing at a raised CPAP pressure level together with a short period of low pressure (Release).

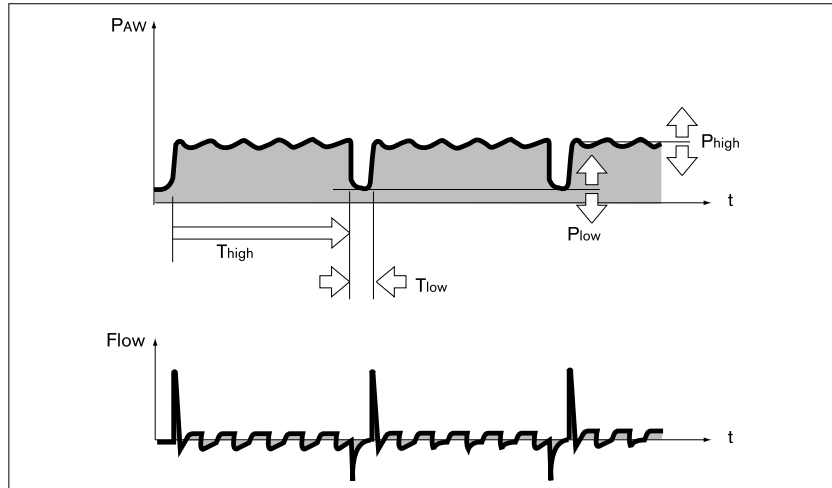

Set the pattern of ventilation for APRV with the ventilation parameters:

Inspiration time »**T_{high}**«

Expiration time »**T_{low}**«

Inspiration pressure »**P_{high}**«

Positive end-expiratory pressure »**P_{low}**«

O₂ concentration »**O₂**«

Pressure rise time »**Ramp**«

To set:

- Touch the appropriate screen knob.
- Adjust to the desired value = turn rotary knob.
- Confirm setting = press rotary knob.

To view additional text information on APRV:

- Touch the screen key »? ▲«.

APRV can be supplemented to include the following special functions:

- Apnoea ventilation, page 69.
- ATC, page 72.

These functions can be enabled in »Add. settings«.

Setting alarm limits, see page 79.

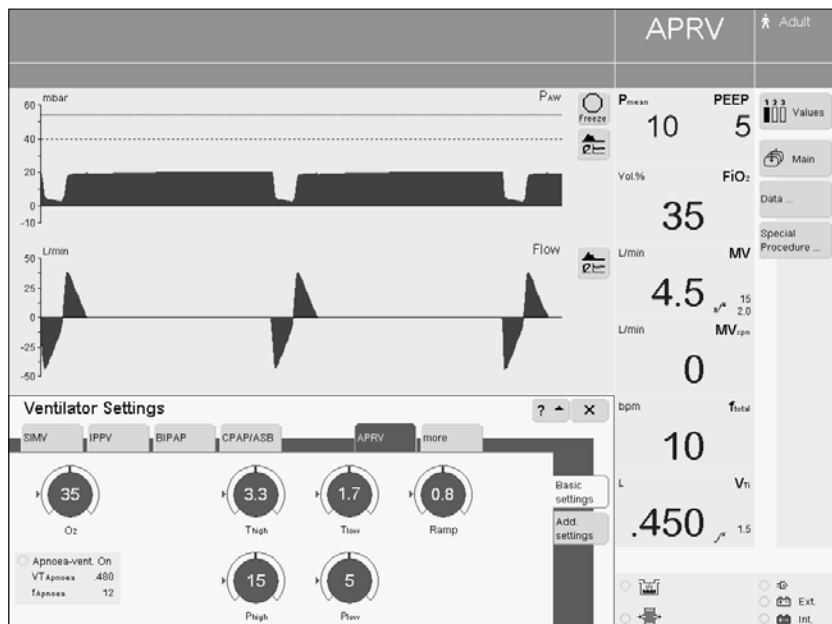

* For a detailed description of APRV, please refer to page 215.

CPAP-ASB

Continuous Positive Airway Pressure Assisted Spontaneous Breathing*

Spontaneous breathing at a raised pressure level in order to increase the functional residual capacity (FRC). Spontaneous breathing can be assisted with additional pressure by ASB.

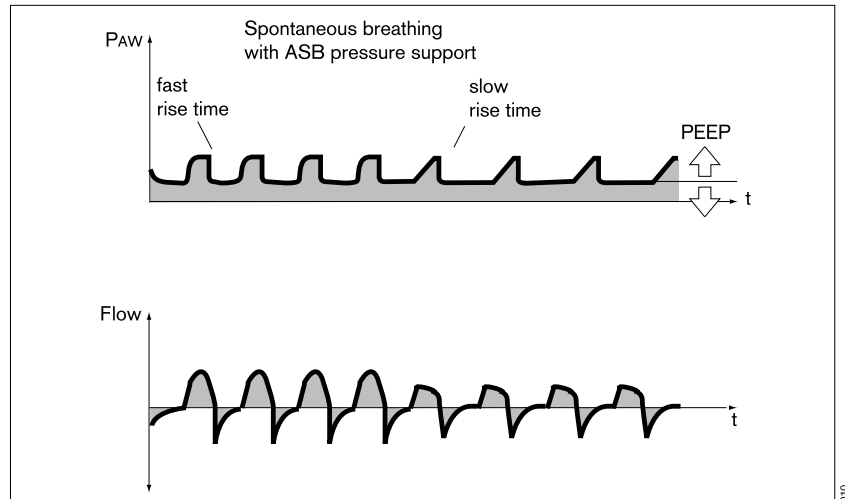

Set the pattern of ventilation for CPAP and CPAP/ASB with the following ventilation parameters:

- O₂ concentration »O₂«
- Positive end-expiratory pressure »PEEP«
- Pressure support »PASB«
- Pressure rise time »Ramp«

To set:

- Touch the appropriate screen knob.
- Adjust to the desired value = turn rotary knob.
- Confirm setting = press rotary knob.

To view additional text information on CPAP, CPAP/ASB:

- Touch the screen key »? ▲«.

CPAP, CPAP/ASB can be supplemented to include the following special functions:

- Apnoea ventilation, page 69.
- ATC, page 72.
- Flowtrigger, page 68.

These functions can be enabled in »Add. settings«.

Setting alarm limits, see page 79.

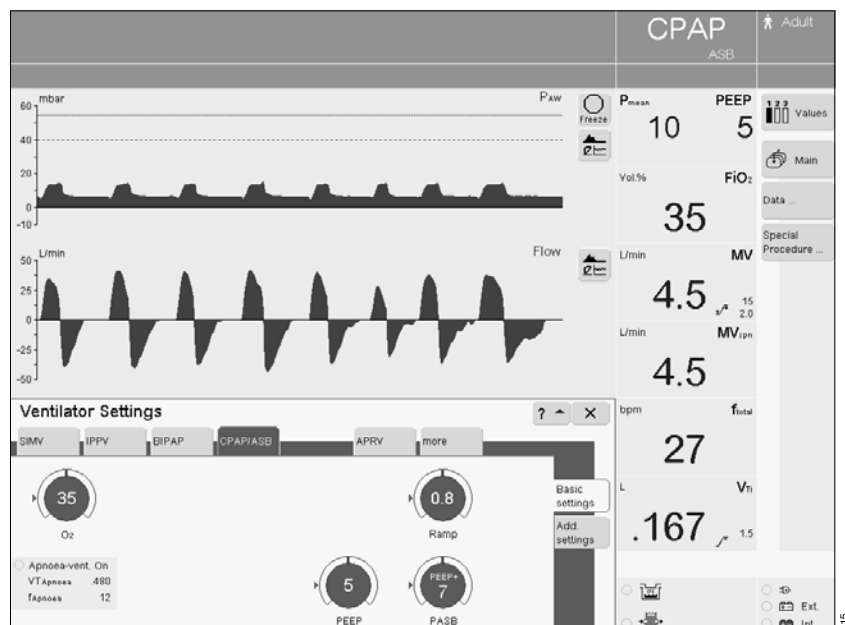

* For a detailed description of CPAP/ASB, please refer to page 216.

PPS (optional)

Proportional Pressure Support*

For differentiated proportional support of spontaneous breathing with pathological compliance and/or resistance.

Volume-proportional elastance compensation (elastance = reciprocal of compliance) (»Vol.Assist«) and flow-proportional resistance compensation (»FlowAssist«) are effective during inspiration.

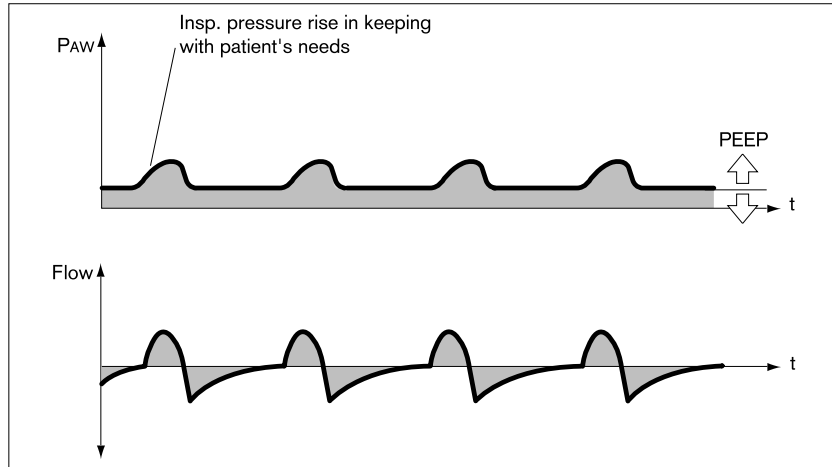

Set PPS with the following ventilation parameters:

- Resistance compensation »FlowAssist«
- Positive end-expiratory pressure »PEEP«
- Elastance compensation »Vol.Assist«
- O₂ concentration »O₂«

To set:

- Touch the appropriate screen knob.
- Adjust to the desired value = turn rotary knob.
- Confirm setting = press rotary knob.

To activate PPS:

- Set the alarm limits $P_{AW} \sqrt{r}$ and $V_T \sqrt{r}$ to protect the patient against pressure and volume trauma.

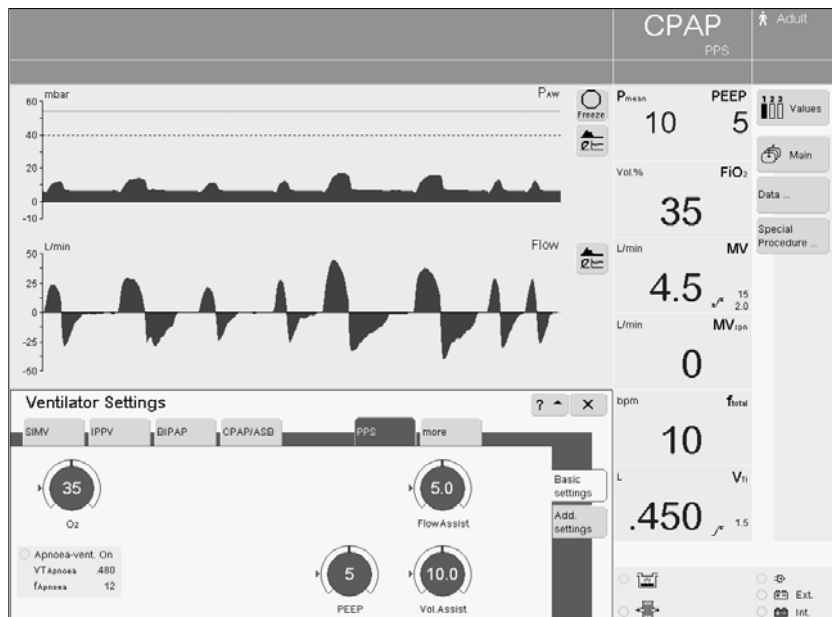

* For a detailed description of PPS, please refer to page 217.

No initial values for PPS

To protect the patient, the parameters »FlowAssist« and »Vol.Assist« are set to 0

- after switching on,
- when the patient weight is entered again or
- after changing the patient mode in ventilation mode PPS.

To view additional text information on PPS:

- Touch the screen key »? ▲«.

PPS can be supplemented to include the following special functions:

- Flowtrigger, page 68.
- Apnoea Ventilation, page 69.
- ATC, page 72.

These functions can be enabled in »Add. settings«.

Setting alarm limits, see page 79.

Setting special functions

The ventilation modes can be combined with the following special functions to optimise ventilation:

- Flowtrigger
- Apnoea Ventilation
- AutoFlow
- ATC
- Sigh
- PLV

Special functions are accessed through »Add. settings«.

To view additional text information:

- Touch the screen key »?▲«.

Ventilation mode	Supplements					
	Flowtrigger	Apnoea ventilation	AutoFlow	ATC	Sigh	PLV
IPPV	X		X	X	X	X
SIMV	X	X	X	X		X
MMV	X		X	X		X
ILV Master	X			X	X	X
ILV Slave				X	X	X
BIPAP	X	X		X		
BIPAP _{Assist}	X			X		
APRV		X		X		
CPAP/ASB	X	X		X		
PPS (optional)	X	X		X		

To review, activate or set:

In the menu »Ventilator Settings«

- Touch the screen key »Add. settings«.

EvitaXL displays the menu with the overview of additional settings available for the accessed or active mode.

Example:

Additional settings for IPPV

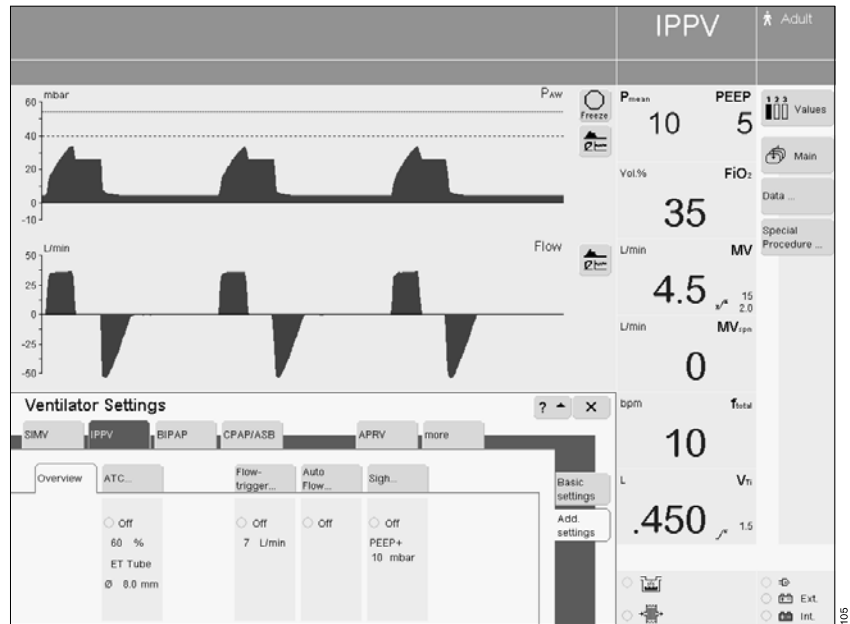

- Touch the corresponding screen key, e.g. »Flowtrigger...«

EvitaXL displays the menu for setting values and for activation/deactivation.

- Touch the screen knob, set = turn rotary knob, confirm = press rotary knob.

To activate/deactivate:

- Touch the screen key »On« or »Off«, confirm = press rotary knob.

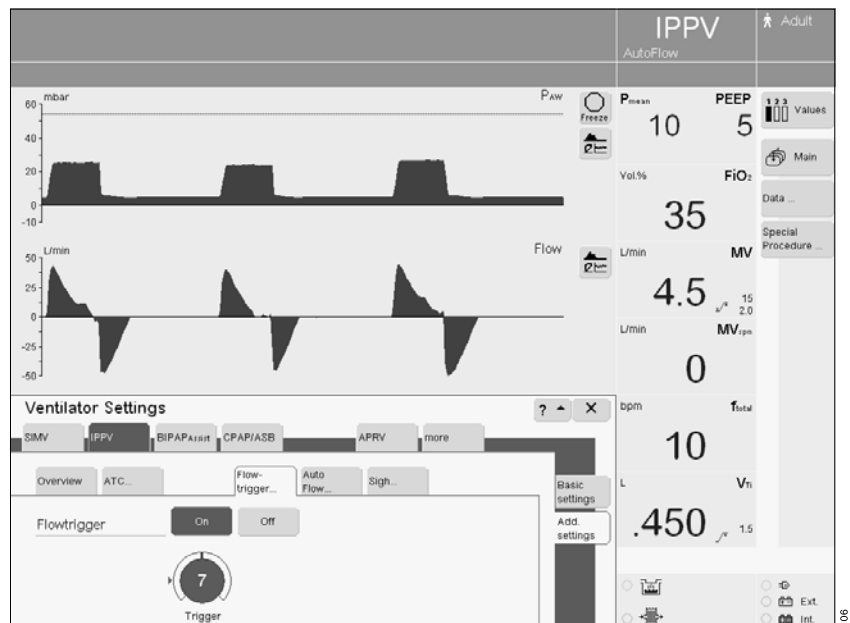

Flowtrigger

for synchronisation with spontaneous breathing efforts.

The mandatory strokes are synchronised with the patient's spontaneous breathing efforts when the flowtrigger is activated and a trigger level is set. Spontaneous breathing activity by the patient is indicated by the brief appearance of a lung symbol instead of the symbol for patient mode.

The flowtrigger is set with the »Flowtrigger« parameter.

To set:

- Touch the screen key »Add. settings« in the required ventilation mode. The possible additional settings are displayed by EvitaXL.
- Touch the screen key »Flowtrigger...«. EvitaXL displays the menu for setting the flowtrigger.
- Touch the screen knob »Trigg. [L/min]«, set = turn rotary knob, confirm = press rotary knob.

To activate / deactivate:

- Touch the screen key »On« or »Off«, confirm = press rotary knob.

The flowtrigger can only be disabled in the IPPV mode of ventilation.

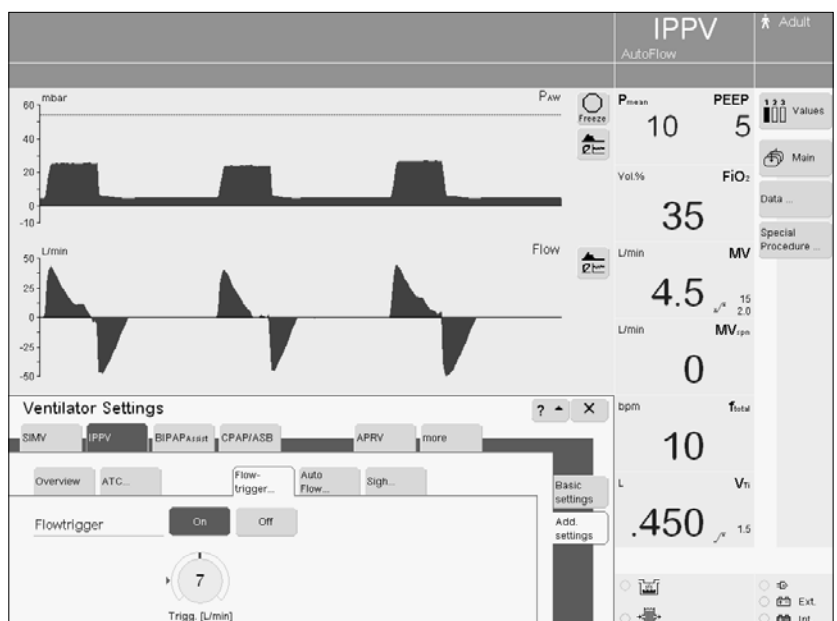

Apnoea Ventilation

For automatic switch-over to volume-controlled mandatory ventilation if the patient stops breathing.

It can be switched on in the ventilation modes SIMV, BIPAP, CPAP, APRV.

EvitaXL outputs an apnoea alarm if no expiration flow is measured or insufficient inspiratory gas is delivered during the set apnoea time T_{Apnoea} (adjustable, see "Setting alarm limits", page 79). EvitaXL will then start volume-controlled ventilation with the set ventilation parameters:

Frequency »f«

Tidal volume »VT«

The ventilation parameters »O₂« and »PEEP« correspond to the settings effective at the time. The inspiration time for apnoea ventilation is determined from the set frequency »f« and a fixed I:E ratio of 1:2.

As in SIMV, the patient can breathe spontaneously during apnoea ventilation, and the mandatory ventilation strokes will be synchronised with the patient's spontaneous breathing. The apnoea ventilation frequency remains constant.

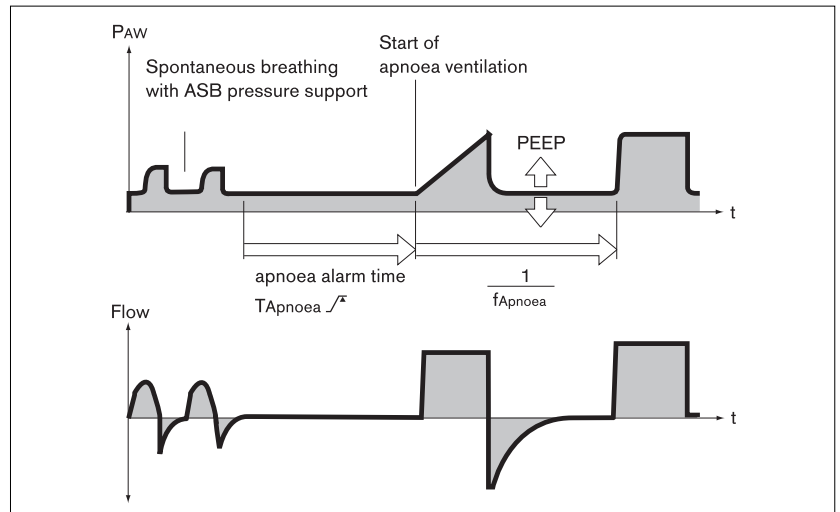

To set:

- Touch the screen key »Add. settings« in the required ventilation mode. The possible additional settings are displayed by EvitaXL.
- Touch the screen key »Apnoea ventilation...«, EvitaXL displays the menu for setting the apnoea ventilation.
- Touch the screen knobs »VT« and »f«, set = turn rotary knob, confirm = press rotary knob.

To activate/deactivate:

- Touch the screen key »On« or »Off«, confirm = press rotary knob.

The status of apnoea ventilation is displayed by EvitaXL on the main screen.

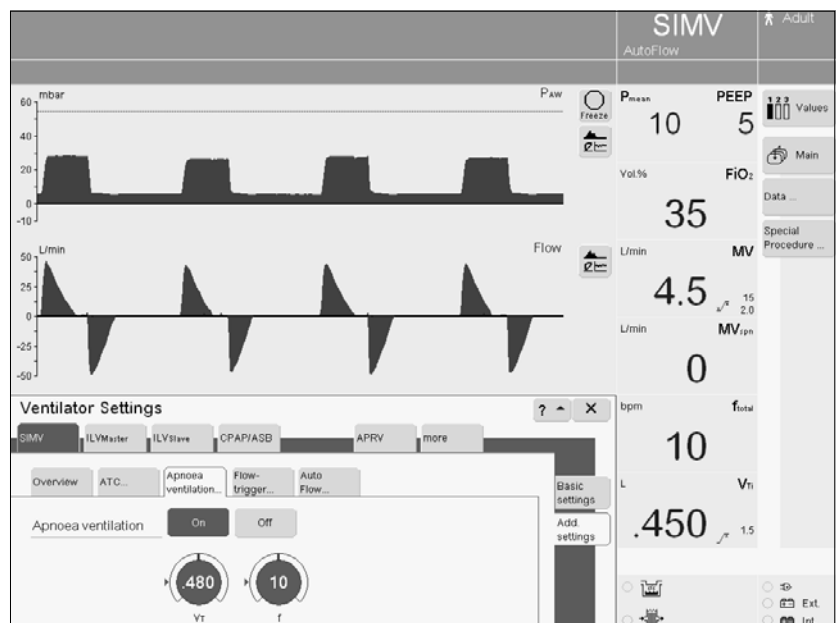

To terminate Apnoea Ventilation:

- Touch the screen key »**Alarm Reset**«, confirm = press rotary knob.

EvitaXL returns to the previously set ventilation mode or

- select a different ventilation mode.

AutoFlow

for automatic regulation of "Insp. Flow" and "P_{insp}".

EvitaXL uses AutoFlow to decelerate and regulate the inspiratory flow by providing a constant pressure throughout the inspiration phase. The ventilator determines the lowest peak pressure for the selected V_T and the patient compliance, thereby avoiding pressure peaks.

EvitaXL delivers an additional inspiration flow when the patient breathes in – this flow is limited by the alarm limit V_{Ti}. The patient can also breathe out during the inspiratory plateau phase. The inspiratory pressure is limited by the alarm limit P_{AW}.

- The alarm limit for V_{Ti} must be set with care in order to prevent over-inflation of the lung following rapid changes in compliance, for example.

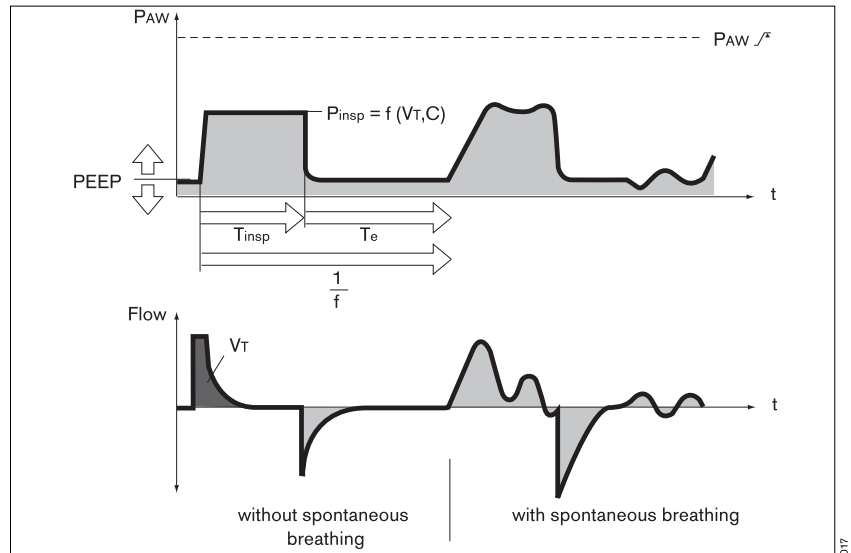

To set:

- Touch the screen key »Add. settings« in the required ventilation mode. The possible additional settings are displayed by EvitaXL.
- Touch the screen key »AutoFlow...«.

To activate/deactivate:

- Touch the screen key »On« or »Off«, confirm = press rotary knob.

The AutoFlow status is displayed by EvitaXL on the main screen.

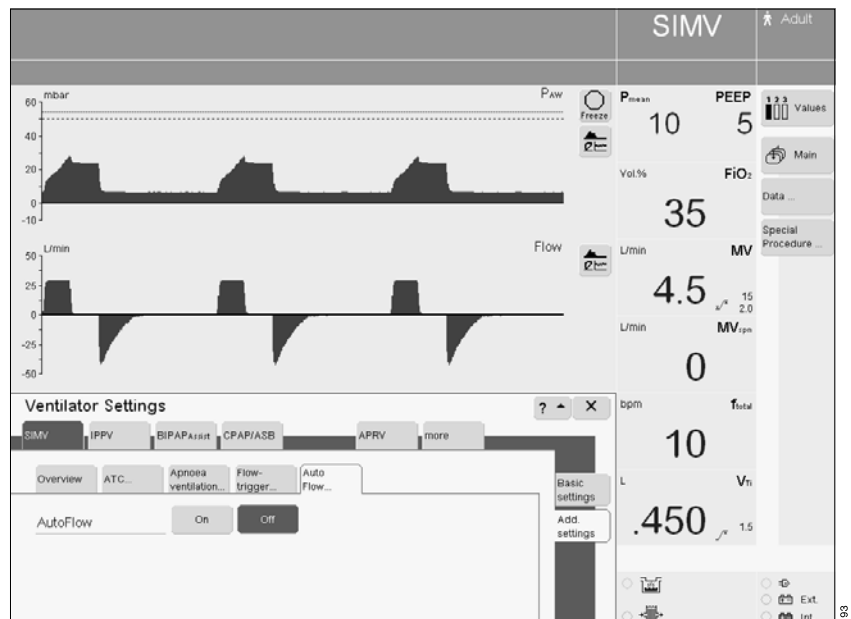

ATC*

Automatic Tube Compensation**

Automatic compensation of the tube resistance

Supplementary function allowing the ventilation pressure in the hose system to be increased during inspiration and decreased during expiration. The airway pressure is adjusted to the tracheal level if 100 % compensation of the tube resistance has been selected.

Automatic tube compensation is active in:

- spontaneous breathing phases
- pressure-supported breathing phases
- pressure-controlled mechanical ventilation phases
- volume-controlled mechanical ventilation phases with activated supplementary "AutoFlow".

Expiratory tube compensation can be deactivated.

In volume-controlled ventilation modes with constant inspiratory flow (IPPV, IPPV_{Assist}, SIMV, MMV), automatic tube compensation is only active during mechanical expiration and the spontaneous breathing phases.

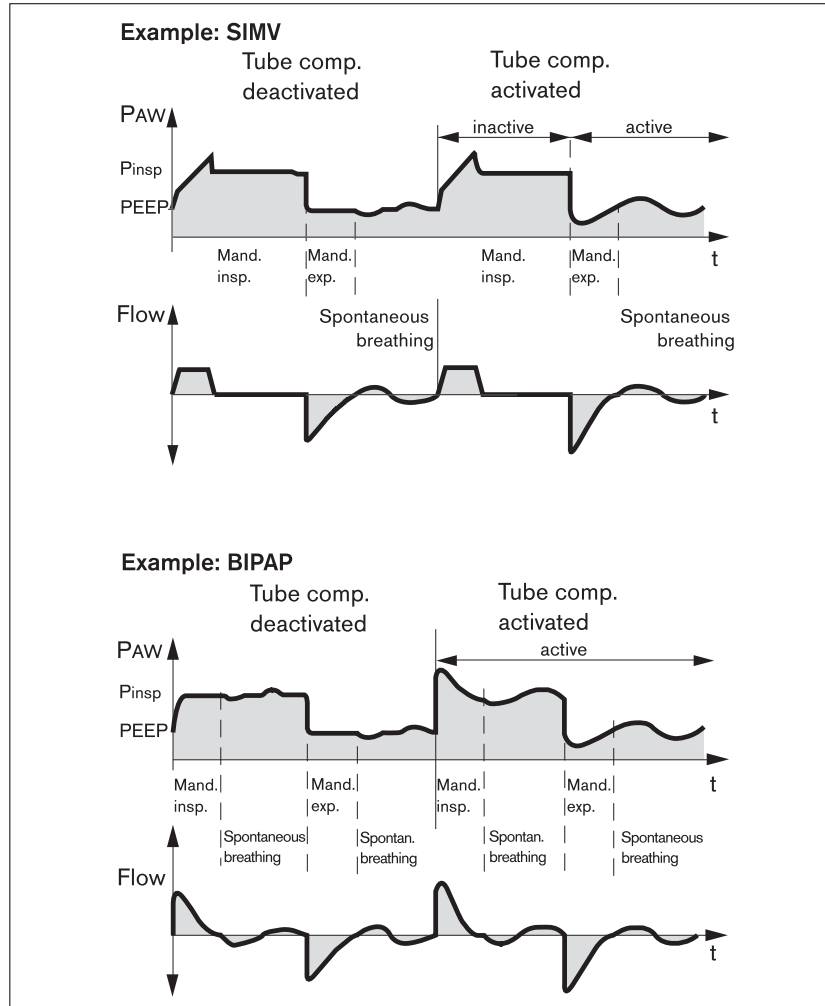

Setting parameters for ATC:

Tube mode »ET« (endotracheal tube) or »Trach.« (tracheotomy tube)

Inside diameter of the tube »ID Ø« in mm

Degree of tube compensation »Comp.« in %

Tube compensation »On«/»Off«

* An Evita 4 or Evita 2 dura unit which has been upgraded with the EvitaXL option can also be operated without ATC option.

** For a detailed description, please refer to page 221.

To set:

- Touch the screen key »Add. settings« in the required ventilation mode. The possible additional settings are displayed by EvitaXL.
- Touch the screen key »ATC...«, EvitaXL displays the menu for setting the ATC.

Select tube:

- Touch the screen key »ET« or »Trach.«.
- Touch the screen knob »ID Ø«, set value = turn rotary knob, confirm = press rotary knob.
- Touch the screen knob »Comp.«, set value = turn rotary knob, confirm = press rotary knob.

To activate/deactivate:

- Touch the screen key »On« or »Off«, confirm = press rotary knob.

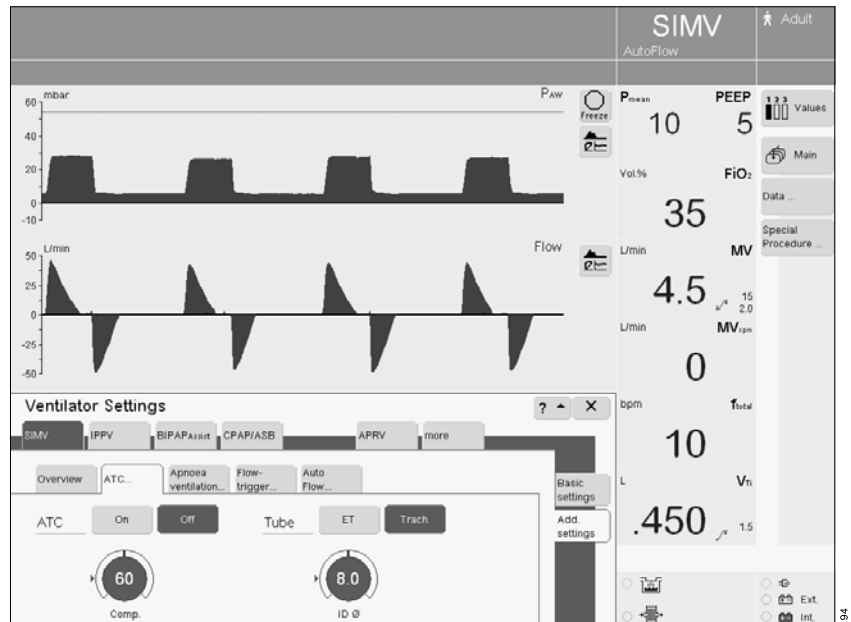

Activated tube compensation is indicated by EvitaXL by the tube symbol  and tube diameter in the status line.

When tube compensation is activated, EvitaXL calculates the tracheal pressure on the basis of the selected tube (regardless of the selected degree of compensation) and displays the value in the pressure curve together with the pressure at the Y-piece as a green line.

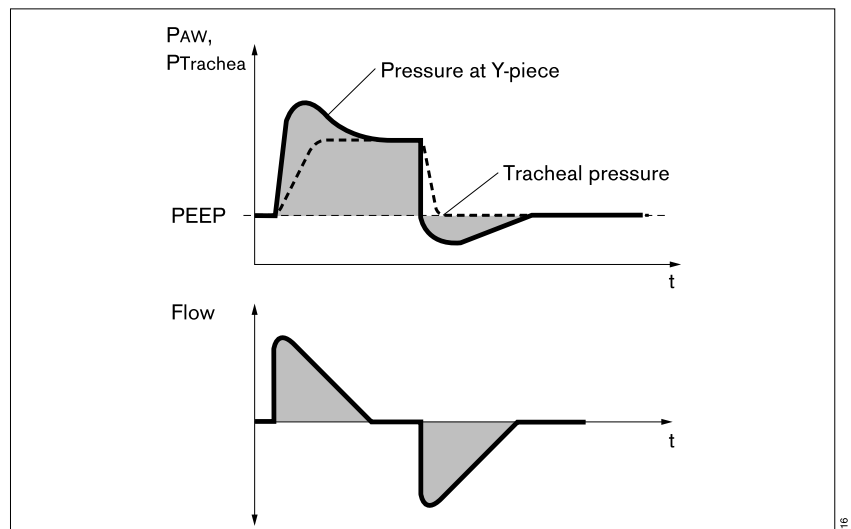

Sigh

Atelectasis can be prevented by activating the Sigh function* and setting the sigh in the form of an intermittent PEEP. When the Sigh function is activated, the end-expiratory pressure increases by the set value of the intermittent PEEP for two ventilation strokes every 3 minutes.

Sigh is set with the parameter: intermittent PEEP »**int.PEEP**«.

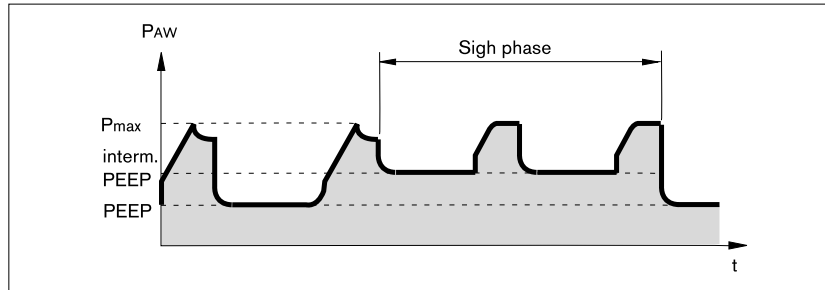

119

To set:

- Touch the screen key »**Add. settings**« in the required ventilation mode. The possible additional settings are displayed by EvitaXL.
- Touch the screen key »**Sigh...**«, EvitaXL displays the menu for setting the Sigh function.
- Touch the screen knob »**int.PEEP**«, set = turn rotary knob, confirm = press rotary knob.

To activate/deactivate:

- Touch the screen key »**On**« or »**Off**«, confirm = press rotary knob.

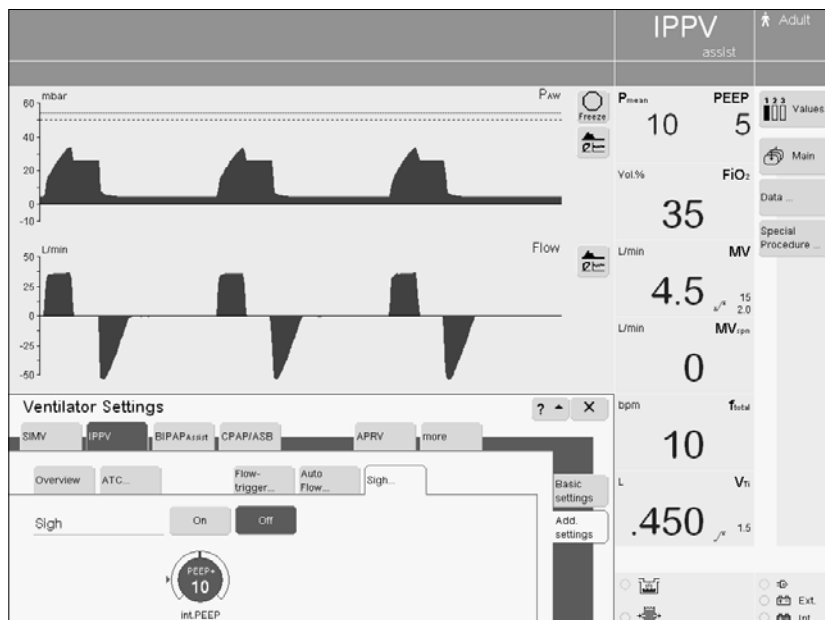

201

* For a detailed description of the Sigh function, please refer to page 210.

PLV*

Pressure Limited Ventilation

Supplementary function for variable limitation of pressure peaks using the P_{max} pressure limit in ventilation modes IPPV and SIMV.

The tidal volume remains constant as long as the pressure curve shows a plateau and the flow curve shows a brief flow pause between inspiration and expiration.

- Activate/deactivate pressure limitation P_{max} , see "Configuration, Set initial values for O₂, I:E...", page 140.

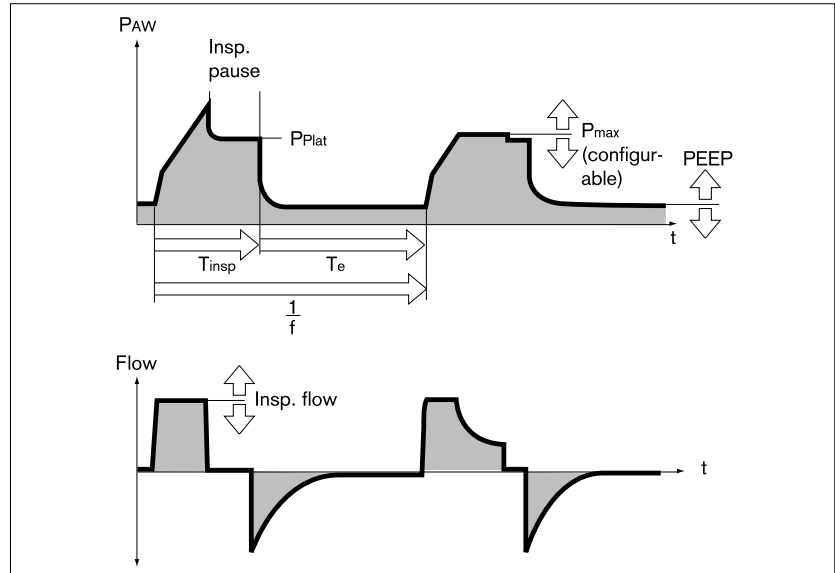

- 1 When pressure limitation is active, the value for P_{max} is shown in the real-time curve PAW (t) as a blue line.
- 2 The screen knob » P_{max} « is additionally displayed in the menu »Ventilator Settings«.

Volume monitoring is active. The alarm "Vol. not constant, pressure limited!!" is automatically triggered if the tidal volume VT can no longer be applied. This visual and acoustic alarm can be reset via the screen key »Alarm Reset« at the top of the screen until the cause of the alarm is remedied.

Set PLV with » P_{max} «.

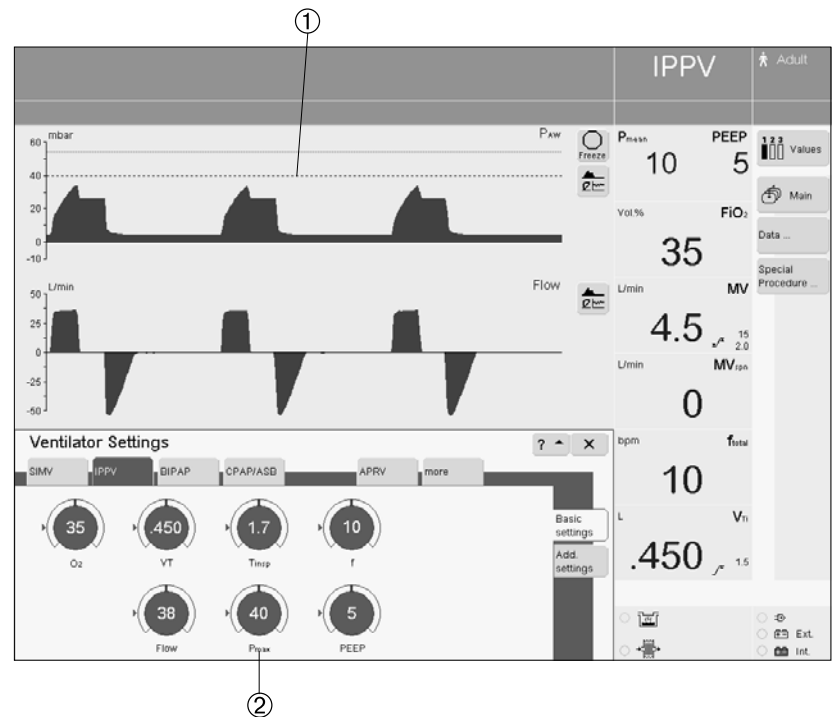

* For a detailed description of PLV, please refer to page 208.

NIV mask ventilation (optional)

Non-Invasive Ventilation

Application mode »Mask« for ventilation with a nasal or facial mask to support non-invasive ventilation of patients with spontaneous breathing.

Choice between mask ventilation and ordinary ventilation of intubated patients.

- NIV option may only be installed by specialists in accordance with the corresponding documentation.

Using NIV

Use of masks increases the dead space.

- **Note the mask manufacturer's directions!**

**Apnoea cannot always be detected reliably.
SpO₂ monitoring must be used if available.**

- **Application mode »Mask« must not be activated with intubated patients!**

- **Alarm limits and ventilation settings must be checked or restored in order to ensure complete monitoring of ventilation after changing from »Mask« mode to »Tube« mode.**

- **High airway pressures must be avoided, risk of aspiration!**

All ventilation modes except »ILV« can be selected in »Mask« mode.

The automatic tube compensation (ATC option) activated in »Tube« mode is ineffective in »Mask« mode.

Selecting application mode »Mask«

Mode can be selected when switching on or during operation.

- Press key »Start/Standby«.
- In the menu »Start/Standby«:
- Touch the screen key »Standby«, it turns yellow.
- Confirm = press rotary knob, the key turns green and the ventilator is now in standby mode.
- Touch the screen key »Tube/Mask« and
- touch the screen key »Mask (NIV)«, the key turns yellow.
- Confirm = press rotary knob, the key turns green and the ventilator is now in »Mask« mode.

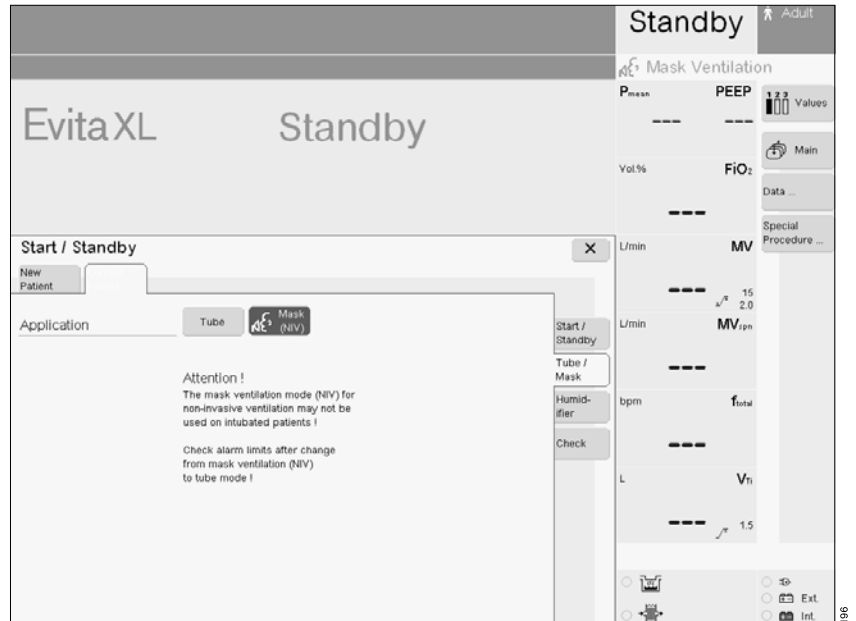

Setting ventilation parameters for NIV

- As described for »Tube« mode.

An additional screen knob is displayed for CPAP/ASB: »Tinsp«

The maximum duration of an ASB stroke is limited by EvitaXL to 4 seconds in patient mode »Adult« and to 1.5 seconds in patient mode »Paediatric«.

- The maximum duration of an ASB stroke can be limited via the screen knob »Tinsp«.

»Tinsp« also limits the duration of the ASB stroke in the other ventilation modes which can be combined with ASB.

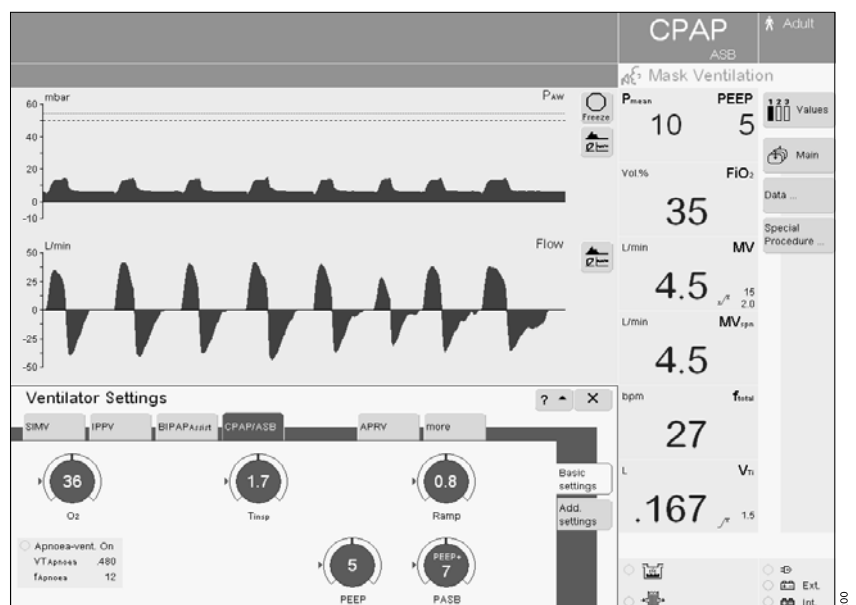

Monitoring in »Mask« mode

The measured values for MV and VT_e are not leakage-compensated and are therefore lower than the actual minute or tidal volume applied to the patient if a leak occurs. EvitaXL compensates leaks of up to 30 L/min for adults and up to 15 L/min for children. Pressure-controlled ventilation is recommended in the case of larger leaks.

In order to avoid false alarms and ensure monitoring:

- Adjust both alarm limits for MV in line with the actual value.
- Use additional monitoring, e.g. SpO₂, if necessary.

The following alarms may be deactivated in order to avoid artefacts:

- MV \swarrow , lower alarm limit, minute volume
- VT_i \nearrow , upper alarm limit, inspiratory tidal volume
- TApnoea \nearrow , upper alarm limit, apnoea monitoring
- See "Setting alarm limits", page 79.

- **Alarms should only be deactivated if the safety of the patient is not jeopardized by the absence of an alarm!**

An advisory message is constantly displayed in the alarm field if an alarm limit has been deactivated.

EvitaXL automatically selects the configured default alarm limits when changing over to »Tube« mode.

A time-lag »TDisconnect« between 0 and 60 seconds can be set for the alarm limit PAW \swarrow (airway pressure low).

The following alarms are not displayed by EvitaXL in »Mask« mode:

- ASB > 4 s
- ASB > 1.5 s
- ASB > T_{insp}
- Leakage

- **Alarm limits and ventilation settings must be checked or restored in order to ensure complete monitoring of ventilation after changing from »Mask« mode to »Tube« mode.**

Leakage compensation in »Mask« mode

Depending on the set patient mode, EvitaXL compensates leakages up to the following values in order to detect a patient trigger:

Adult mode: 30 L/min

Paediatric mode: 15 L/min

Calculated leakages are compensated by EvitaXL up to 200 % of the set tidal volume, but not more than max. 2 L (regardless of the patient mode).

Setting alarm limits

- Press key » $\sqrt{\wedge}$ Alarm Limits«.

EvitaXL opens the menu »Alarm Limits«.

$\sqrt{\wedge}$ = upper alarm limit

$\sqrt{\vee}$ = lower alarm limit

The values for the upper and lower alarm limit shown in the screen keys are initial values which are effective whenever the ventilator is switched on. However, they can also be configured specifically as required by the hospital, see "Configuration", page 126.

The actual measured value is displayed between the upper and lower alarm limits.

To set:

- Touch the required screen key, it turns yellow, set = turn rotary knob, confirm = press rotary knob.

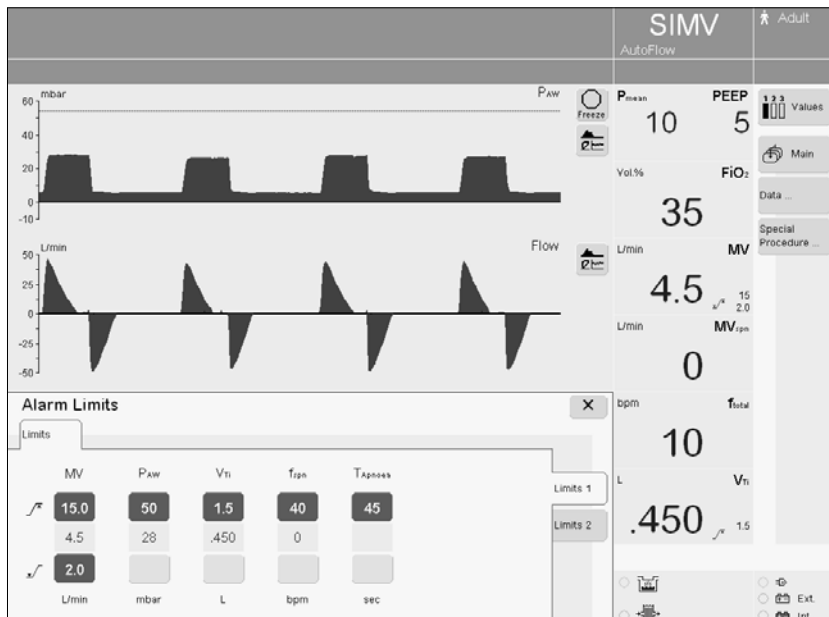

The alarm limits for the optional measured value etCO₂ can be viewed by touching "Limits 2".

- Touch the screen key »Limits 2«.

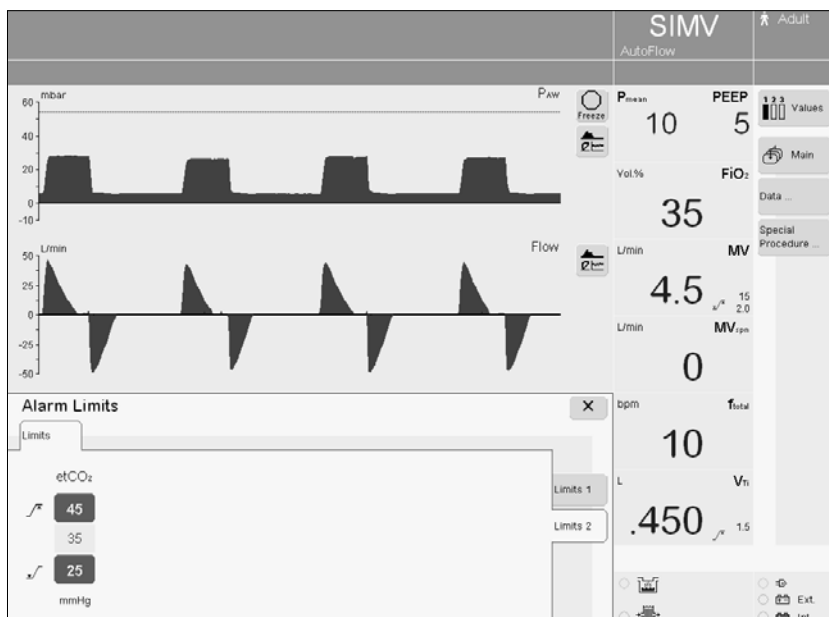

To deactivate (MV $\sqrt{\vee}$ for example):

- »Reduce »MV $\sqrt{\vee}$ « until the following advisory message is displayed: »MV $\sqrt{\vee}$ off? Press and turn rotary knob«
- Confirm advisory message = press rotary knob.
- Continue turning rotary knob until dashes (--) appear on the display.
- Confirm = press rotary knob.

In the event of an alarm

- 1 The corresponding message is displayed in the top left-hand line of the screen.

Example:

Tidal volume high !!!

The EvitaXL assesses the alarm message with corresponding priority, marks the text with exclamation marks and different coloured backgrounds and generates the various alarm tone sequences.

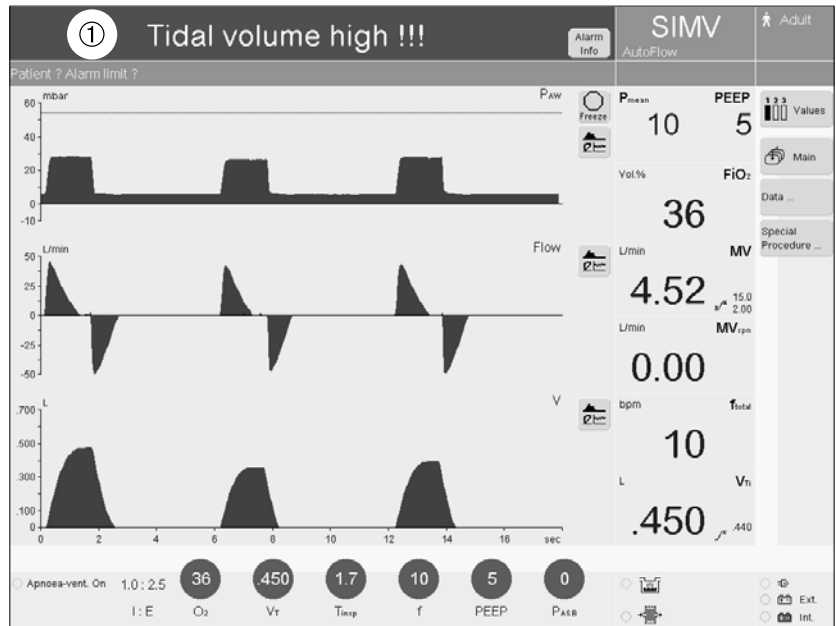

Alarm = top priority message

Alarm messages are identified by three exclamation marks and appear against a red background.

Example: **Tidal volume high !!!**

EvitaXL generates a 5-tone sequence that is sounded twice and repeated every 7 seconds.

Caution = medium priority message

Cautions are identified by two exclamation marks and appear against a yellow background.

Example:

O2 supply pressure high !!

EvitaXL generates a 3-tone sequence which is repeated every 20 seconds.

Advisory = low priority message

Advisory messages are identified by one exclamation mark and appear against a yellow background.

Example:

Fan malfunction !

EvitaXL generates a 2-tone sequence which is sounded only once.

Remedy the fault

- Refer to the list "Fault – Cause – Remedy" on page 144

or

- 1 Touch screen key »Alarm Info«. All momentarily active messages are displayed.
- Select message with rotary knob.
- Touch the screen key »?▲«. The message is displayed on the screen with cause and remedy.

The alarm tone ceases automatically when the fault has been remedied. Cautions and advisory messages disappear automatically.

Alarm messages (!!!) appear in the colour of the status line and must be acknowledged:

- Touch the screen key »Alarm Reset«, confirm = press rotary knob.

The message is deleted from the screen. However, it is saved in EvitaXL and can be displayed in the logbook on the »Data« screen via the logbook function, see page 89.

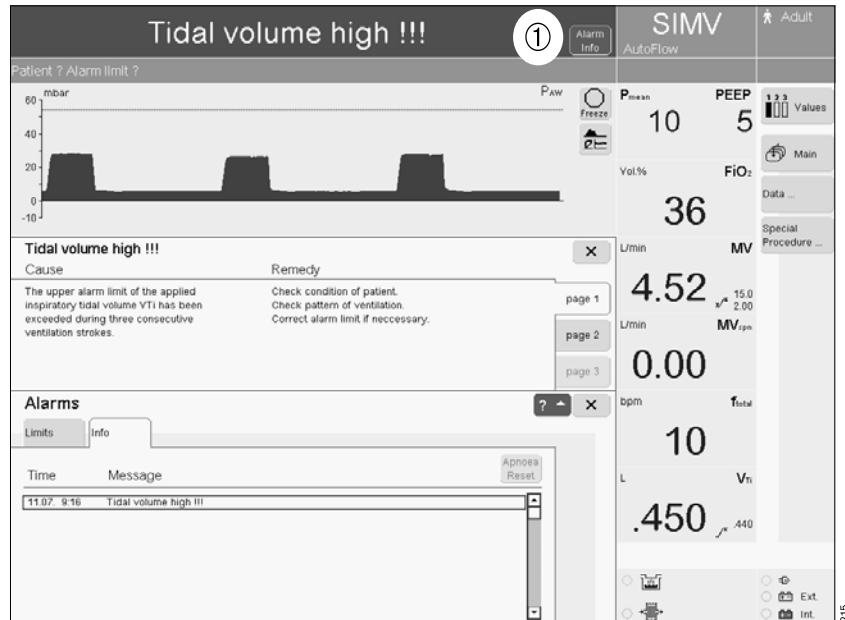

The caution message

Apnoea ventilation !!

may be overlaid by messages or alarms with higher priority. For this reason, the message can also be reset via the screen key »Apnoea Reset«:

- Touch screen key »Alarm Info«.
- 2 Touch screen key »Apnoea Reset«, confirm = press rotary knob.

EvitaXL continues ventilation with the previously set ventilation mode.

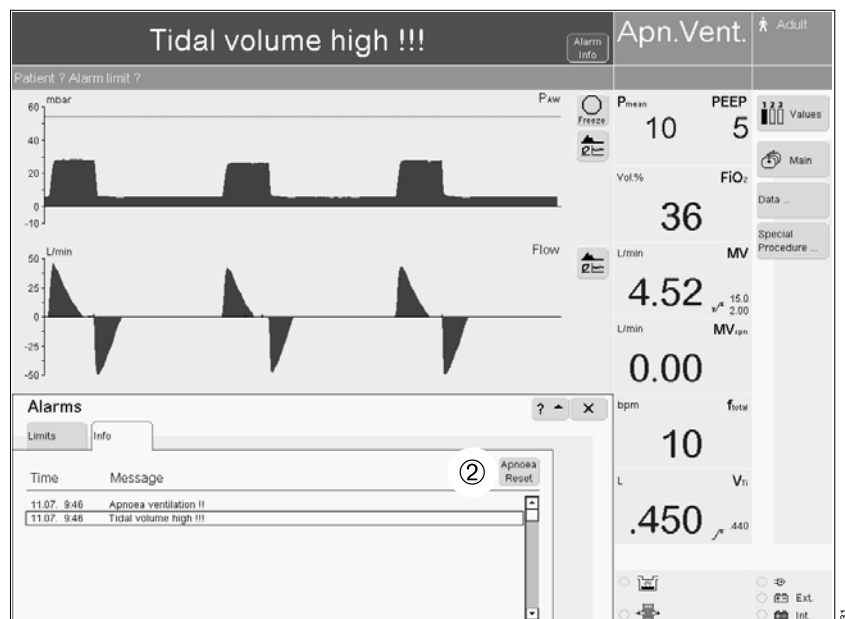

Setting alarm limits
 Suppress alarm tone
 Power failure alarm

Suppress alarm tone

for max. 2 minutes:

- 1 Press key » **Alarm Silence**«, its yellow LED lights up.

The acoustic alarm is suppressed for two minutes.

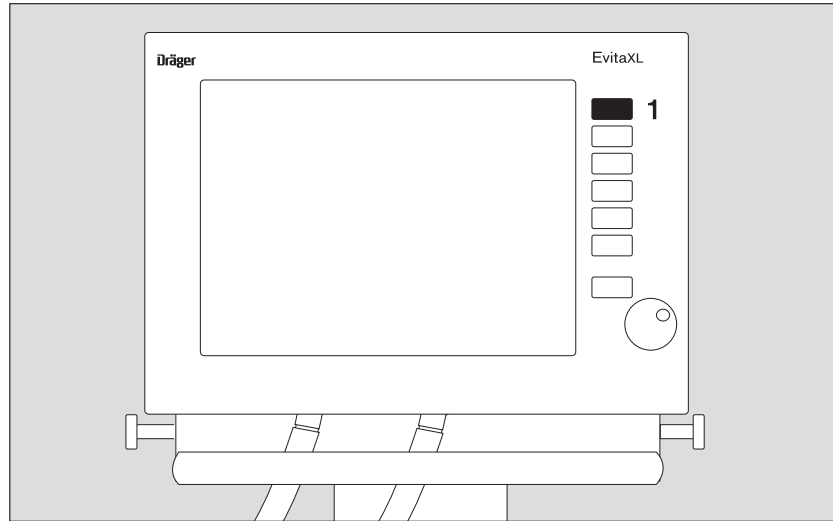

- 2 The remaining time is displayed on the screen.

If the fault triggering the alarm has not been remedied after 2 minutes, the acoustic alarm sounds again.

If the acoustic alarm is to be re-activated prematurely:

- 1 Press key » **Alarm Silence**« again, its LED goes out.

Acknowledge:

See "Fault – Cause – Remedy", page 143, for alarms which can be reset via the Alarm Reset key.

- Touch the screen key »**Alarm Reset**«, confirm = press rotary knob.

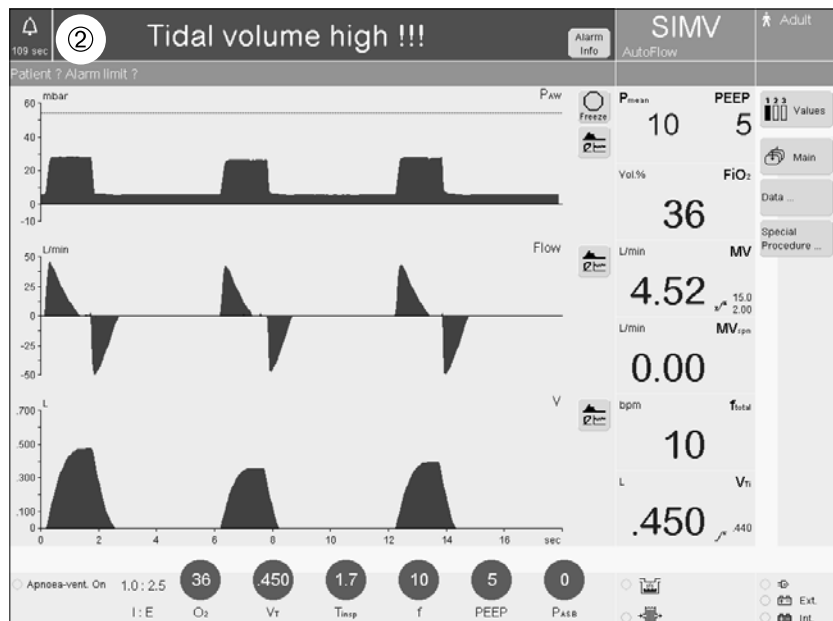

Power failure alarm

If the loudspeaker for acoustic alarm signalling fails on account of a defect, a continuous tone will be generated by an auxiliary alarm. This continuous tone also draws attention to a power failure (see page 30, in the event of an interruption in the power supply).

Displaying graphics

The following real-time curves can be displayed:

- PAW (t)
- Flow (t)
- Volume (t)
- etCO₂ (t) (optional)
- Pleth (optional)
- a real-time curve combined with a short trend or a Recruitment Trend (breath-based trend) (optional).

- Touch the function key »  **Main**«.

To select other real-time curves:

- Touch the relevant screen key »  « and EvitaXL opens the menu »**Curves**«.
- Touch the screen key »**Curve only**«.
- Touch the screen key for the required parameter of the real-time curve.
- The EvitaXL displays the real-time curve of the parameter. The menu disappears automatically.
- To freeze real-time curves, see "Freeze" on page 85.

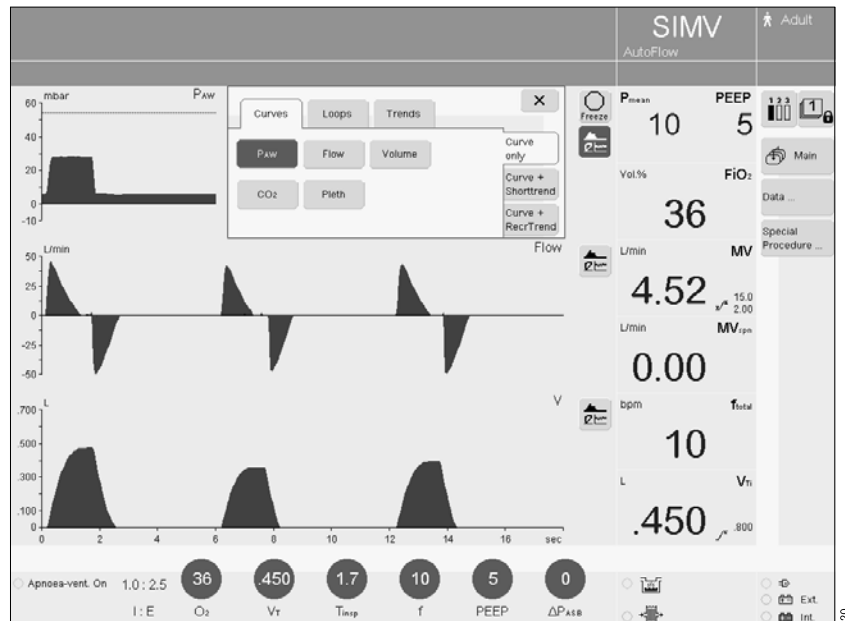

To display the real-time curve in combination with a short trend:

In the menu »**Curves**«

- Touch the screen key »**Curve + Shorttrend**«.

The required real-time curve can be combined with the short trend for any chosen parameter.

The relevant real-time curve is displayed in the menu and the screen key of the corresponding short-trend parameter appears in dark green.

- Touch the screen key of the required parameter for the corresponding short trend.

EvitaXL displays the short trend of the associated parameter over the last 20 minutes on the left, beside the real-time curve.

The other two real-time curves are also automatically combined with a short trend.

If parameters have not been selected for the short trends, EvitaXL displays the parameters previously selected for the short trend.

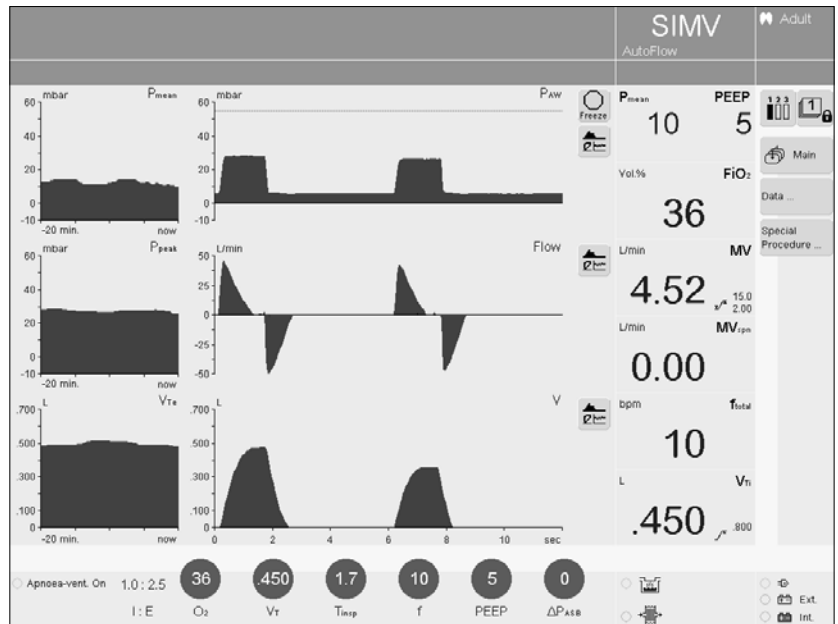

Display real-time curve combined with Recruitment Trend*:

In the menu »Curves«

- Touch the screen key »Curve + RecrTrend«.

The respective real-time curve can be combined with the breath-based trend of the selectable parameters »EIP/PEEP«, »VTe« and »C«.

- Touch the screen key of the required parameter for the corresponding Recruitment Trend.

To view a point on the curve at a certain moment in time:

- Turn the rotary knob to position the cross-hair cursor over the required point and the corresponding measured value is displayed above the curve.

If the cross-hair cursor is moved out of the displayed segment, the displayed time segment is automatically shifted.

- to the right – new time segment,
- to the left – old time segment.

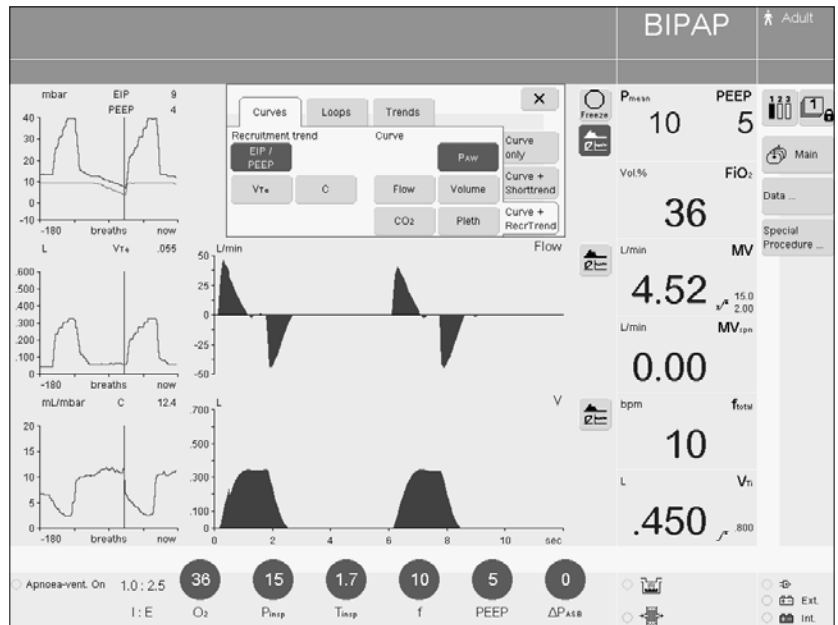

* Lung Protection Package option

Freeze

To freeze the current real-time curve or loop.

- Touch the screen key »  **Freeze** « – it turns dark green with a red symbol. The momentary curves and loops are recorded and then stop.

To view a point on the curve at a certain time or a pair of values in a loop:

- Turn the rotary knob to position the cross-hair cursor over the required point and the corresponding measured value or pair of values will be displayed above or beside the curve.

Freeze mode is automatically ended by EvitaXL three minutes after touching the screen key or three minutes after the rotary knob was last turned.

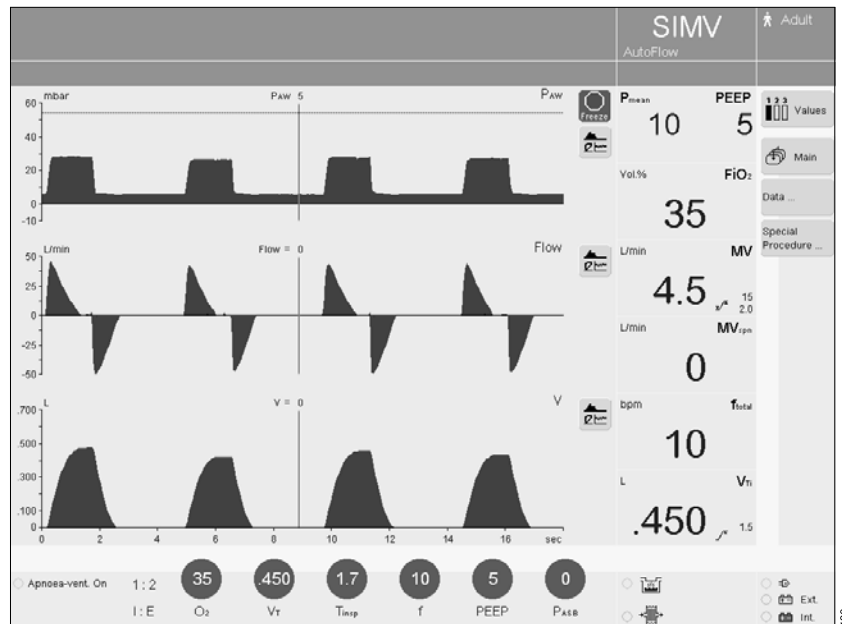

To view new curves/loops:

- Press the screen key »  **Freeze** « again – the current curves or loops are once again recorded.



Loop display

This mode is used to display two measured values which appear in the ventilation cycle as a loop, such as the PAW-V loop or the V-Flow loop.

- Touch the function key »  **Main** «.
- Touch the required screen key »  «.
- Touch the screen key » **Loops** «. The menu » **Loops** « is displayed by EvitaXL.

Loops can be displayed in different forms:

- Two small loops, one on the left, the other on the right

or:

- an enlarged loop on the left.

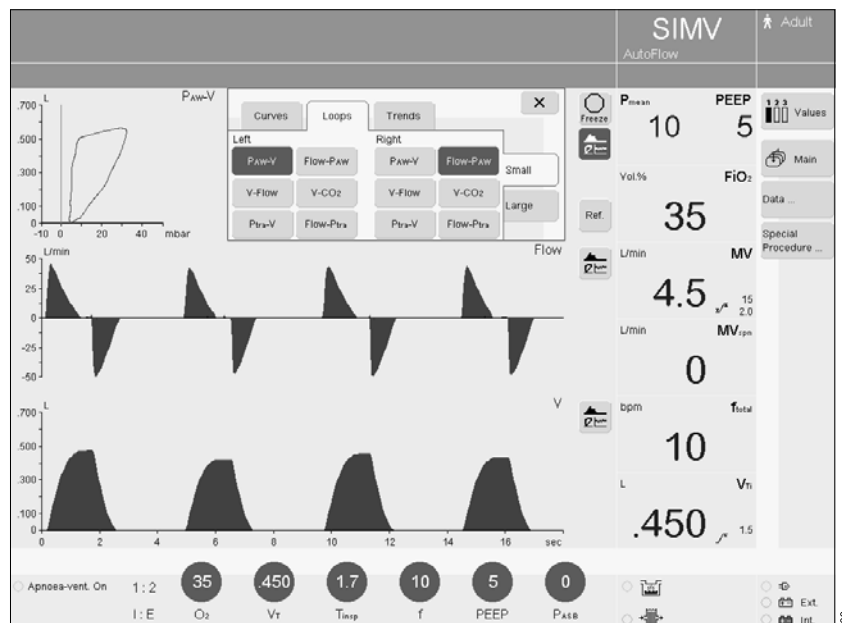

To display small loops:

- Press the screen key »Small«.

To display a large loop:

- Press the screen key »Large«.

Select the required parameter combination:

- Touch the screen key for the required parameter combination.

A list of possible parameter combinations is displayed on the screen.

- Select and confirm the parameter combination via the rotary knob.

All the loops for a ventilation cycle are recorded by the ventilator, such as the loop for the mandatory ventilation stroke in SIMV mode and the loop for a spontaneous breath stroke, if any.

To obtain a single loop:

- Touch the screen key »Single breath« – every single loop is recorded afresh by EvitaXL.

To obtain a reference loop:

- Touch the screen key »Ref.« at the required time to record a reference loop.



The reference loop is drawn in blue and appears constantly in the current loop displayed. The time at which the reference loop was recorded appears on the left beside the »Ref.« key.

- To freeze loops, see "Freeze", page 85.

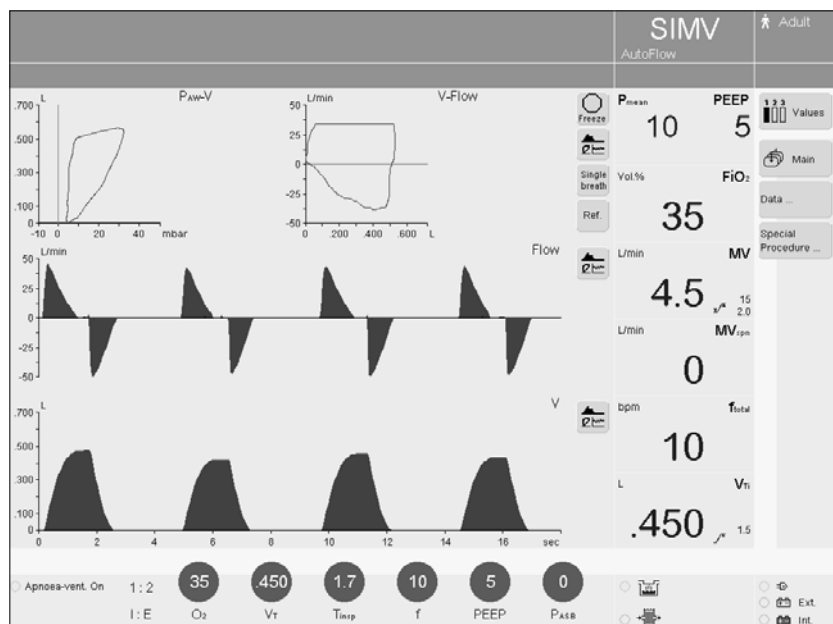
The screen key »Ref.« is ineffective when the loop has been frozen via the screen key »Freeze«.



Display 1 hr trend

- Touch the function key »  **Main**«.
- Touch the required screen key »  «.
- Touch the screen key »**Trends**«. EvitaXL displays the parameters for trend display.

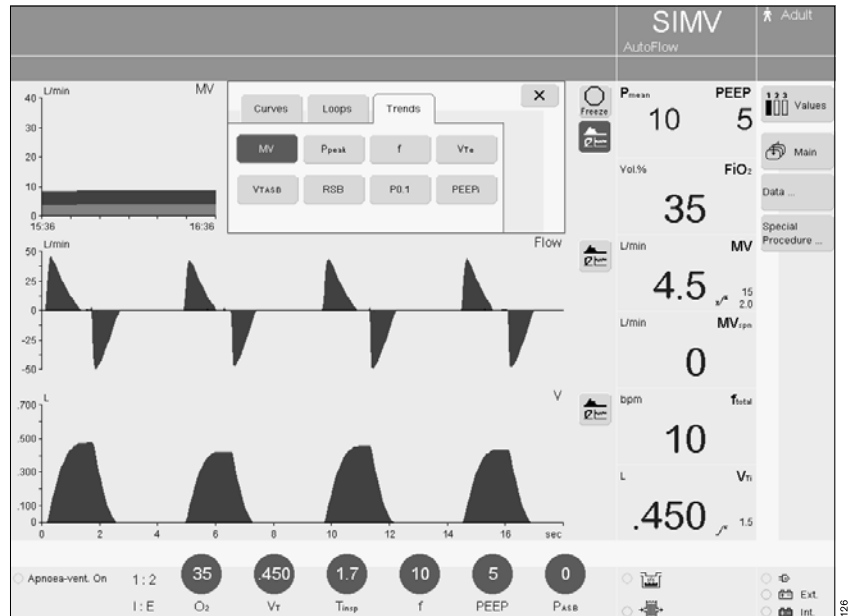

- Touch the required parameter key and EvitaXL displays the trend during the last hour for the selected parameter.

To view a value in the trend at a certain moment in time:

- Turn the rotary knob to position the cross-hair cursor over the required point.

The value is displayed in the trend display at the top.

The cross-hair cursor cannot be moved if the trend has been frozen via the screen key »  **Freeze**«.

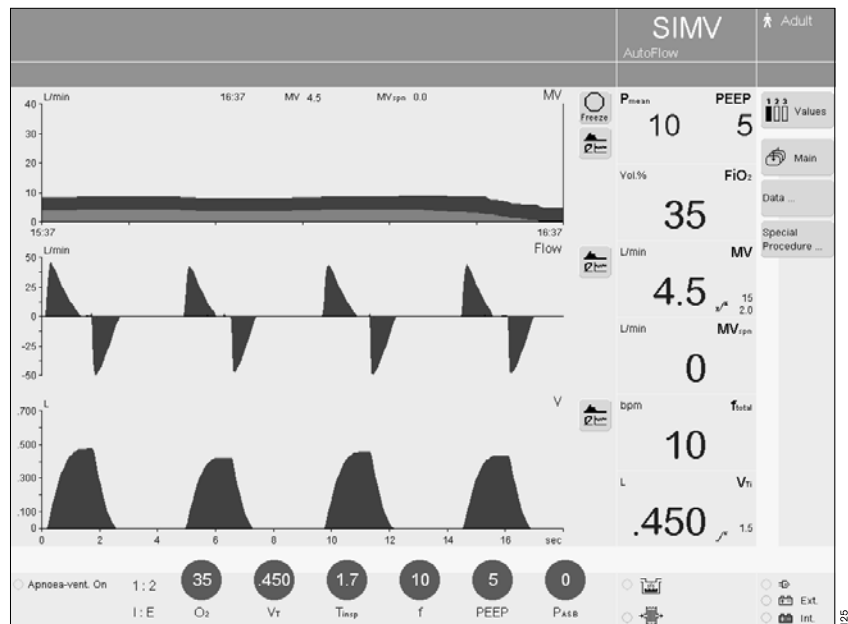

Display measured values

- Touch the function key »**1 2 3 Values**«. The bar in the key representing the main numerical values and active alarm limits shown on the right of the screen turns black.

Two further options can be selected on EvitaXL:

- Touch the function key »**1 2 3 Values**« again. The bar in the key representing the next selection turns black and the corresponding values are displayed by EvitaXL.
- Proceed accordingly to view the third option.

The three options have been defined by the manufacturer, however can also be configured specifically as required by the hospital, see "Configuration", page 126.

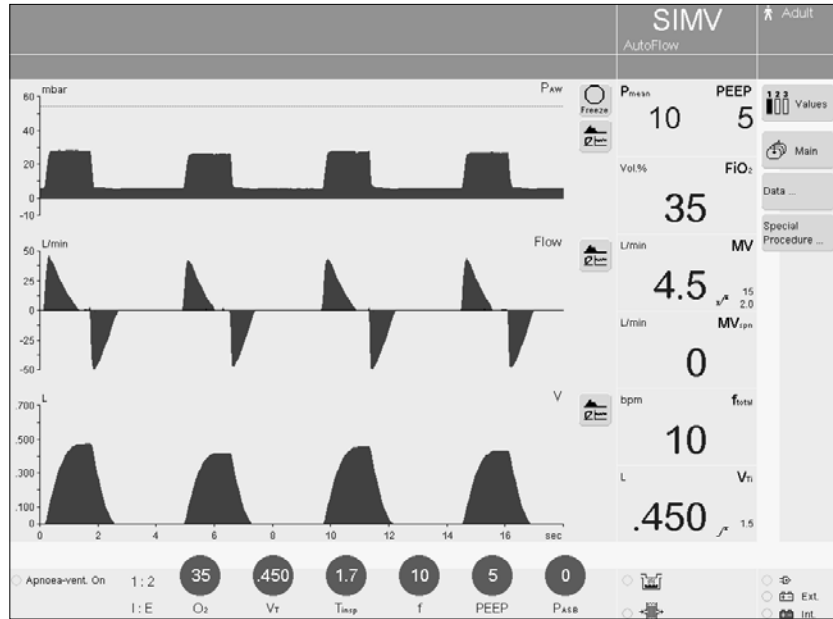

Display all measured values and settings

EvitaXL displays all measured values and settings in two tables for documentation. The values and settings specific to the hospital can be compiled in a third table, see "Configuration", page 126.

- Touch the function key »**Data...**«. EvitaXL displays the menu »**Data**«, with the submenu »**Values**«.

The table of specific hospital values and settings is displayed as default and the screen key »**Custom. Table**« is white.

Select table 1 or table 2:

- Touch the screen key »**Table 1**« or »**Table 2**«.
- Touch the screen key »**X**« to close the table.



Display logbook

Changes, events and alarms are registered by EvitaXL and listed in chronological order with the date and time of occurrence.

Changes are displayed with the former and new settings (example: 5 mbar -> 7 mbar).

Events include, for instance, use of a medicament nebuliser, Flow calibration, etc.

Alarms are registered in the form displayed by EvitaXL at the time of occurrence. Other alarms which are triggered with the displayed alarm but are not themselves displayed in the field for alarm messages are identified by an asterisk (*) preceding the entry in the logbook.

To display the logbook:

- Touch the function key »Data...«, the »Data« menu is displayed.
- Touch the screen key »Logbook« and EvitaXL displays the logbook.

When a time is highlighted in the trend display (page 90), the line corresponding to that time is also marked in the logbook.

For the highlighted line, EvitaXL displays the complete list of new settings for every registered change in parameters for the ventilation mode effective at that time.

To view all the settings for another line:

- Turn the rotary knob to select the required line.
- Touch the screen key »x« to close the logbook.



Display trends (1 to 24 hr)

- Touch the function key »Data...«.
 - Touch the screen key »Trends«.
- EvitaXL displays three trends with a common time scale one below the other.

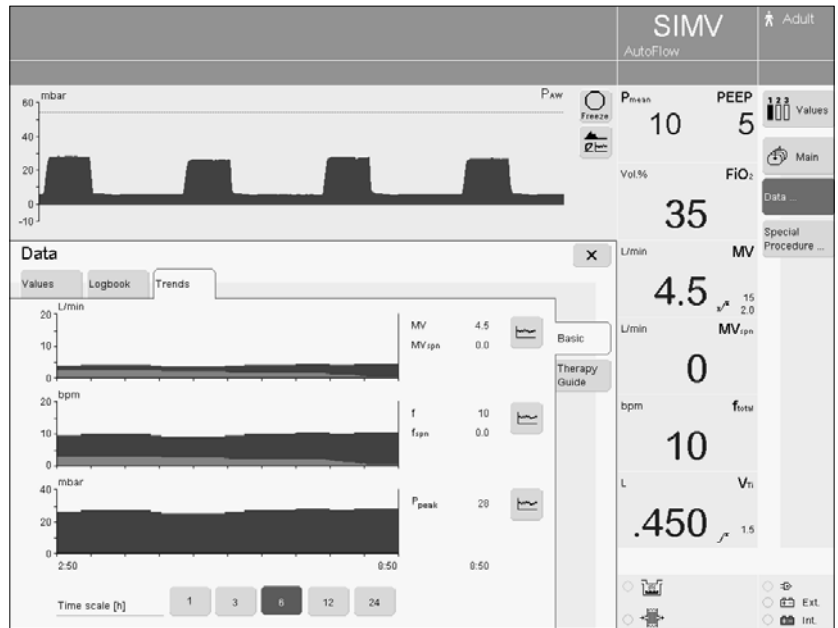

Select the parameter or parameter combination required for the trend display:

- Touch the relevant screen key »«.
 - Touch the required screen key for the parameter/parameter combination.
- The trend is displayed and the menu disappears.

Select the common time scale in increments of 1, 3, 6, 12, 24 hr:

- Touch the screen key for the required time scale. The key turns green and the selected time scale is effective.

Display a value in the trend for a certain time:

- Turn the rotary knob to position the cross-hair cursor over the required point in time. The value is displayed on the left, beside the screen key »«.
- Touch the screen key »x« to close the trend display.

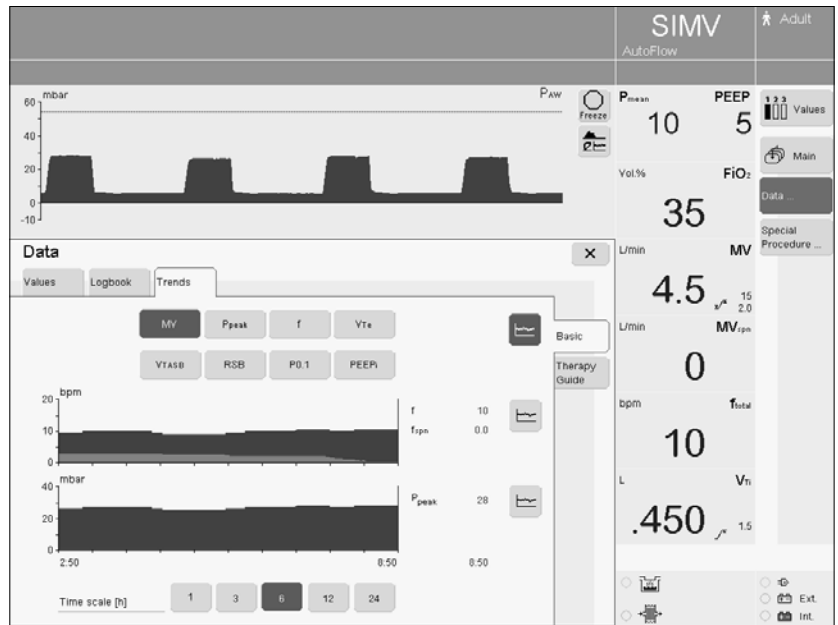

Additional functions

Medicament nebulisation

Inflammable agents must not be nebulised!
They may be ignited by the glowing flow sensor.

During adult ventilation

Applicable in every ventilation mode. EvitaXL applies the medicament aerosol in synchronisation with the inspiratory flow phase and maintains the minute volume constant.

The medicament nebuliser is supplied by the ventilator with medical air, O₂ or a mixture of medical air and O₂ according to the set O₂ concentration. Deviations in the O₂ concentration are thus kept to a minimum.

In extreme cases (with a minimum inspiration flow of 15 L/min), the deviations can be up to ± 4 % by volume*.

To avoid greater deviations, medicament nebulisation is automatically switched off at inspiratory flows below 15 L/min.

During paediatric ventilation

Medicament nebulisation is possible in the pressure-controlled paediatric ventilation modes.

In volume-controlled ventilation modes, medicament nebulisation is only possible with the supplementary AutoFlow[®] function.

Unlike in adult ventilation, the medicament nebuliser nebulises continuously in paediatric ventilation, but the aerosol generated during expiration does not reach the lungs.

Depending on the set O₂ concentration, the medicament nebuliser is supplied with medical air or O₂ or a mixture of medical air and O₂ by the ventilator. Deviations in the O₂ concentration are thus minimised.

For breathing rates above 12 bpm, please refer to the graph on page 228.

The maximum possible deviations in the O₂ concentration are ± 4 % by volume.

We recommend that you do not use the medicament nebuliser at breathing rates of less than 12 bpm.

For breathing rates of less than 12 bpm, the deviations in the O₂ concentration may be much greater in extreme cases.

These deviations cannot be detected by the device's internal O₂-concentration monitor.

The minute and tidal volumes displayed may be considerably higher or lower than those actually applied to the patient on account of tolerances in the nebuliser flow. Pressure-controlled ventilation is therefore recommended during nebulisation. The measured values prevailing before nebulisation must be taken into account if necessary.

If the VT and MV values diverge strongly, the ventilation pressure can be used for assessment of the ventilation. VT and MV values can be compared by comparing the difference between PEEP and plateau pressure before and during nebulisation.

In order to avoid false alarms and ensure monitoring:

- Adjust both alarm limits for MV in line with the actual value.
- Use additional monitoring, e.g. SpO₂, if necessary.

Only the medicament nebuliser 84 12 935 (with white middle part) may be used.

If other pneumatic medicament nebulisers are used, there may be major deviations in tidal volume and inspiratory O₂ concentration!

* For a detailed description of the insp. O₂ concentration during medicament nebulisation, refer to page 228.

- Prepare the medicament nebuliser in accordance with its Instructions for Use.

For use during adult ventilation

- 1 Connect the nebuliser to the inspiratory side (temperature sensor side) of the Y-piece.
 - 2 Connect the inspiration hose to the medicament nebuliser.
- Place the medicament nebuliser in the vertical position.
 - Using clamps, route the nebuliser hose back to the ventilator along the expiratory hose.

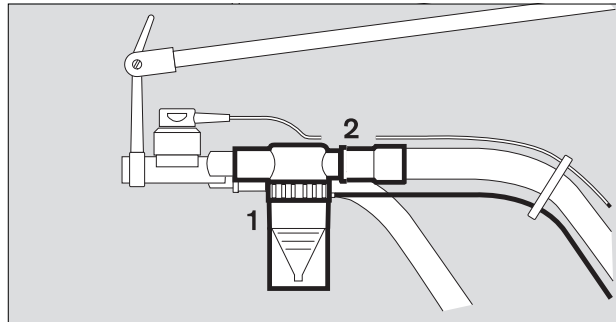

For use during paediatric ventilation

- 3 Insert the catheter connector (ISO cone Ø15/Ø11) in the inlet of the medicament nebuliser.
- 4 Insert the adapter (ISO cone Ø 22/Ø11) in the outlet.
- 5 Fit the corrugated hose (0.13 m long) to the outlet adapter.

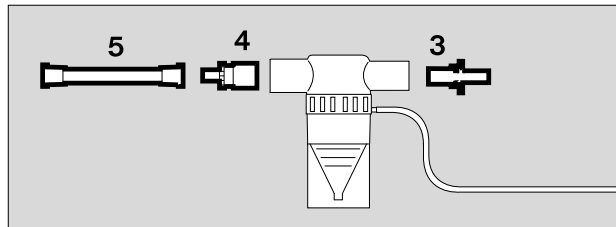

- 6 Remove the corrugated hose of the hose set from the inspiratory adapter of the Y-piece and connect it to the inlet adapter of the medicament nebuliser.
- Connect the free end of the corrugated hose at the outlet of the medicament nebuliser to the inspiratory adapter of the Y-piece.

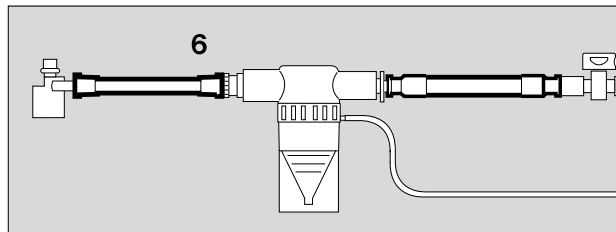

- 7 Connect the nebuliser hose to the port on the front panel of the EvitaXL.

- Fill the medicament nebuliser in accordance with the specific Instructions for Use.

The effect of aerosols on sensors, filters and heat and moisture exchangers (HME) must be taken into account! Do not place a microbial filter on the nebuliser outlet during nebulisation!

The measuring function of the flow sensor may be impaired. The flow resistance of filters is liable to increase and may impair ventilation.

During medicament nebulisation, do not use a heat and moisture exchanger (HME) at the Y-piece. Risk of increased breathing resistance!

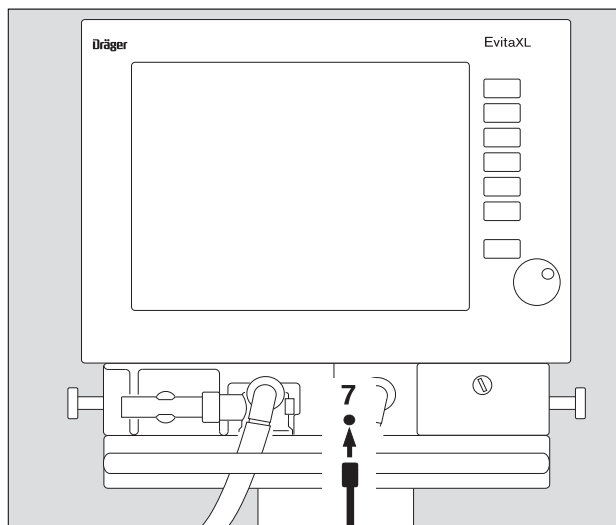

Switch on the medicament nebuliser:

- Touch the function key »**Special Procedure...**«. EvitaXL displays the menu »**Additional Function**«.
- Touch the screen key »: **Nebuliser**«, the key turns yellow.
- Confirm = press rotary knob. The key turns green and the nebuliser is operational. The message **Nebuliser On !** appears on the screen.

Switch off the nebuliser:

- Touch the screen key »: **Nebuliser**«.

The nebuliser is switched off automatically by the ventilator after 30 minutes. The flow sensor is automatically cleaned and calibrated after nebulisation.

Screen display: **Flow calibration**

- Remove remaining medicament. Follow the Instructions for Use of the medicament nebuliser.

To view additional text information:

- Touch the screen key »? «.

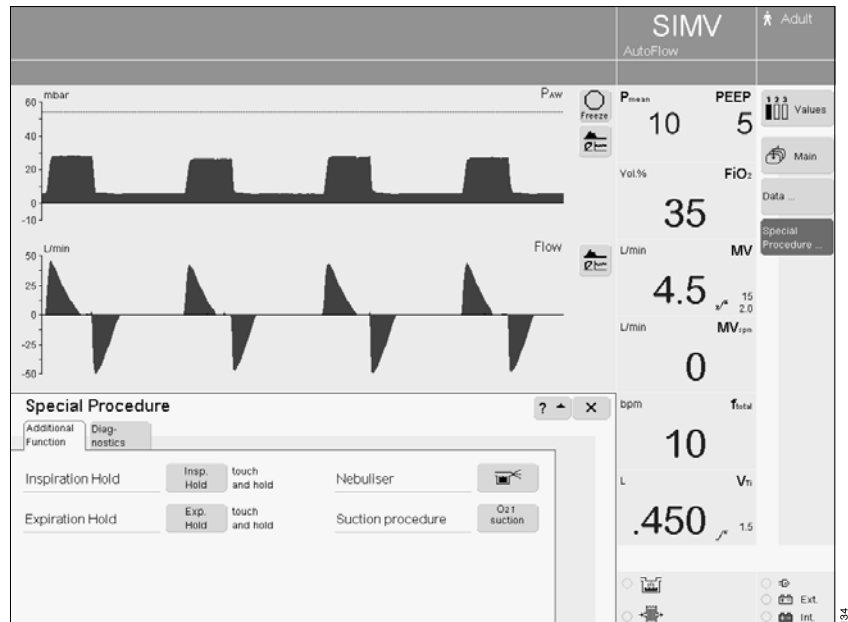

Oxygen enrichment for bronchial suction

To avoid any risk of hypoxia during bronchial suction, EvitaXL offers a procedure for oxygen enrichment during the removal of secretions.

After the program is started, EvitaXL ventilates the patient in the selected ventilation mode for an initial oxygen enrichment phase of 180 seconds.

- In adult mode, the ventilator supplies 100 % by volume O₂, and in paediatric mode it delivers the set O₂ concentration plus 25 % (for example: 60 % by vol. set; administered: 75 % by vol.)

When the ventilator is disconnected for suction, EvitaXL interrupts ventilation. During the suction phase, the audible alarms are suppressed so that the suction routine is not disturbed.

After suction and automatically recognised reconnection, EvitaXL delivers an increased O₂ concentration for the final oxygen enrichment phase of 120 seconds:

- In adult mode, the O₂ concentration is 100 % by volume. In paediatric mode, the enriched concentration is 25 % higher than the set O₂ concentration.

During suction and for 2 minutes afterwards, the lower alarm limit for the minute volume is switched off. Other alarms are switched off during suction and for 15 seconds afterwards.

Oxygen enrichment is only possible with a fully functioning flow sensor and if flow monitoring is switched on!

Before suction

- Touch the function key »Special Procedure...«. EvitaXL displays the menu »Additional Function«.
- Touch the screen key »O₂ ↑ suction«, the key turns yellow.
- Confirm = press rotary knob. The key turns green and the oxygen enrichment program is started.

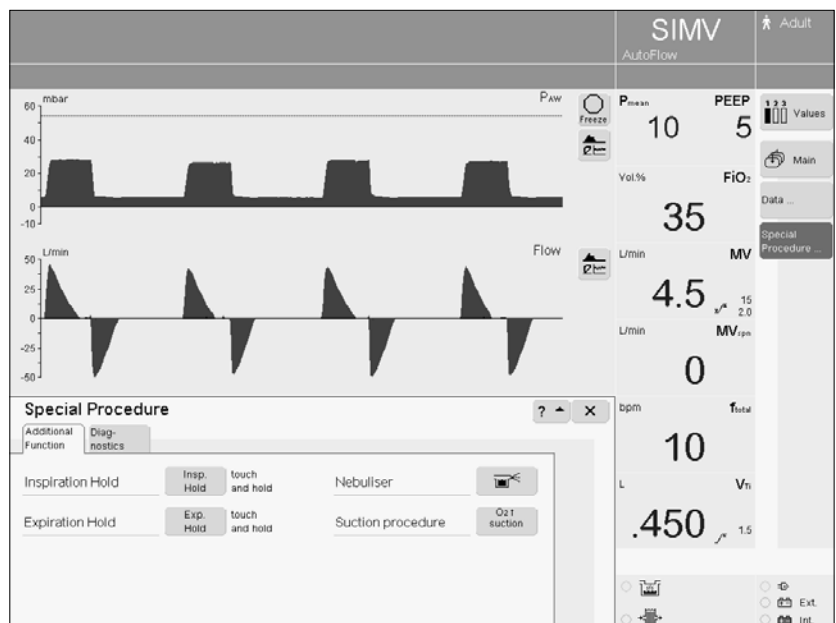

EvitaXL ventilates the patient in the set ventilation mode with increased O₂ concentrations: In adult mode, the O₂ concentration is 100 % by volume. In paediatric mode, the enriched concentration is 25 % higher than the set O₂ concentration. If PEEP is not set to more than 4 mbar, PEEP will be applied automatically at 4 mbar. This PEEP allows EvitaXL to detect any subsequent disconnection.

The other ventilation parameters remain unaffected.

Screen display:

Initial oxygen enrichment 180 s

The remaining time is counted down continuously.

This initial oxygen enrichment lasts for a maximum of 180 seconds.

During this time EvitaXL waits for a disconnection for suction.

The oxygen enrichment program is terminated by EvitaXL if there is no disconnection after the 180 seconds have elapsed.

After disconnection for suction

EvitaXL delivers a minimal flow for the duration of suction in order to detect automatically the end of the disconnection phase. The time available for suction is displayed on the screen continuously in seconds (example):

Execute suction and reconnect 120 s

If suction is ended and the system is reconnected within the displayed time, EvitaXL terminates the disconnection phase.

Automatic interruption of oxygen enrichment

If there is still no reconnection after 120 seconds, the oxygen enrichment program is interrupted. All alarms are immediately reactivated. EvitaXL continues ventilating in the set ventilation mode.

After reconnection

After reconnection, EvitaXL continues ventilating in the set ventilation mode, except that for 120 seconds an O₂ concentration of 100 % by volume for adults or 25 % above the set O₂ concentration for paediatric ventilation will continue to be delivered for final oxygen enrichment.

Screen display:

Final oxygen enrichment 120 s

The remaining time is counted down continuously.

If oxygen enrichment is to be interrupted:

- Touch the screen key »O₂ ↑ suction«.

To view additional text information on oxygen enrichment:

- Touch the screen key »? ▲«.

To quit the menu:

- Touch the screen key »X«.

Manual inspiration

This function may be used in all modes except for spontaneous breathing CPAP. Regardless of the start time, an automatic ventilation stroke can be prolonged for up to 15 seconds.

Or:

Between two automatic ventilation strokes, a ventilation stroke can be manually started and held for max. 15 seconds.

The pattern of the manually started ventilation stroke corresponds to the ventilation pattern of the currently active automatic ventilation mode.

In CPAP/ASB:

a pressure-assisted ventilation stroke (defined by the PASB setting) is triggered.

- Touch the function key »**Special Procedure...**«. EvitaXL displays the menu »**Additional Function**«.
- **Touch and hold** the screen key »**Insp. hold**« for the required inspiration time. Inspiration is ended by the ventilator after max. 15 seconds.

To view additional text information:

- Touch the screen key »?**▲**«.

To quit the menu:

- Touch the screen key »**X**«.

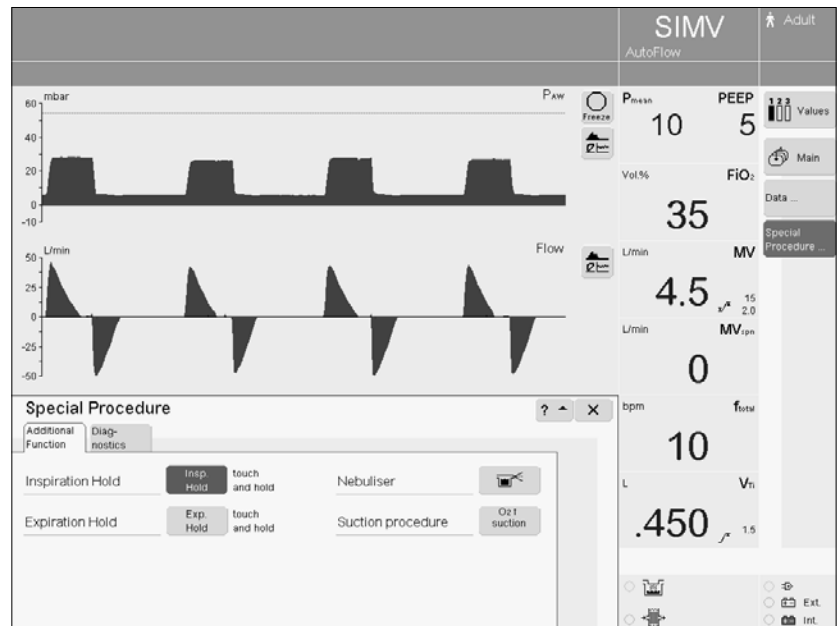

Expiration Hold

This function may be used in all ventilation modes.

For determining the measured NIF* value for weaning.

- Touch the function key »**Special Procedure...**«, EvitaXL displays the menu »**Additional Function**«.
- **Touch and hold** the screen key »**Exp. Hold**« for the required expiration time. Expiration is ended by the ventilator after max. 15 seconds.

To view additional text information:

- Touch the screen key »?**▲**«.

To quit the menu:

- Touch the screen key »**X**«.

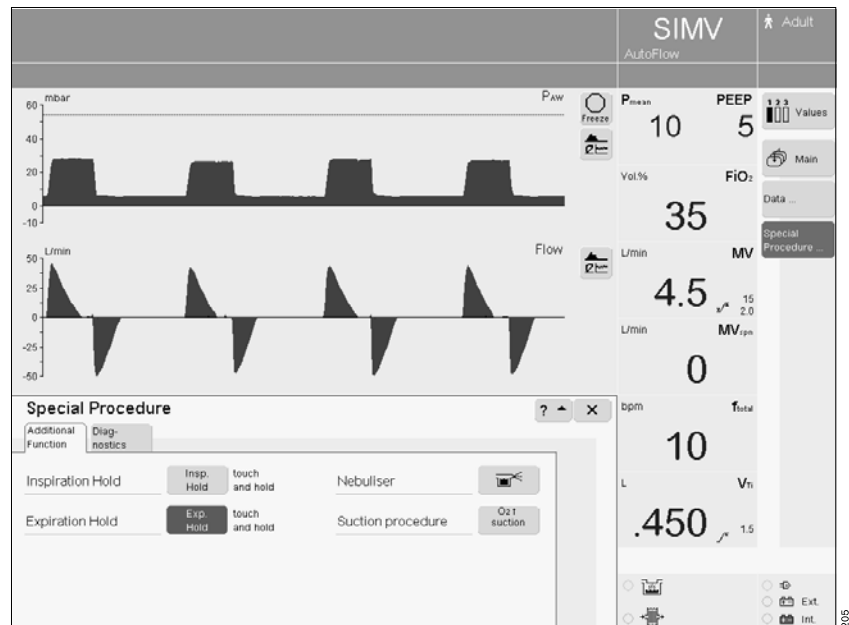

* Display NIF, see page 101.
For a detailed description of NIF, see page 225.

Diagnostic functions

Occlusion pressure P 0.1

The occlusion pressure P 0.1 characterises the negative pressure during a short occlusion (0.1 s) at the start of spontaneous inspiration.

It is a direct measure of the neuro-muscular breathing drive.

EvitaXL displays the value for the measured pressure difference without a negative sign.

For patients with healthy lungs and regular breathing P 0.1 is 3 to 4 mbar. A higher P 0.1 signifies a high breathing drive, which can only be maintained for a brief period. Values below 6 mbar for a patient with chronic obstructive pulmonary disease indicate impending exhaustion.

This special measuring procedure can be used in all ventilation modes at regular intervals in order to check the breathing drive of a spontaneously breathing patient or to assess the amount of spontaneous breathing during controlled ventilation.

- Touch the function key »**Special Procedure...**«. EvitaXL displays the menu »**Additional Function**«.
- Touch the screen key »**Diagnostics**« and the special procedure P 0.1 is preselected.

EvitaXL displays the P 0.1 value for the previous measurement and – in large numerals – the value for the last measurement.

- Touch the screen key »**Start**«, the key turns yellow.
- Confirm = press rotary knob, the screen key turns green and EvitaXL starts the P 0.1 measuring procedure.

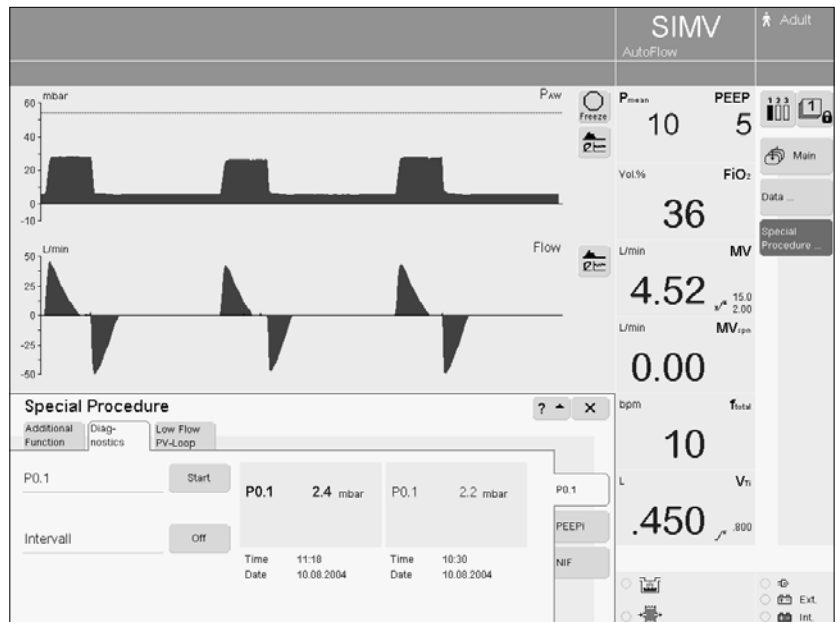

Set the interval

- Touch the screen key »Interval«; the key turns yellow.
Set = turn rotary knob,
confirm = press rotary knob.

The remaining time until the next measurement is displayed.

To view additional text information:

- Touch the screen key »?▲«.

To quit the menu:

- Touch the screen key »X«.

It is advisable to record the measured P 0.1 value as a trend so that the progress made can be monitored, see "Display 1 hr trend", page 87.

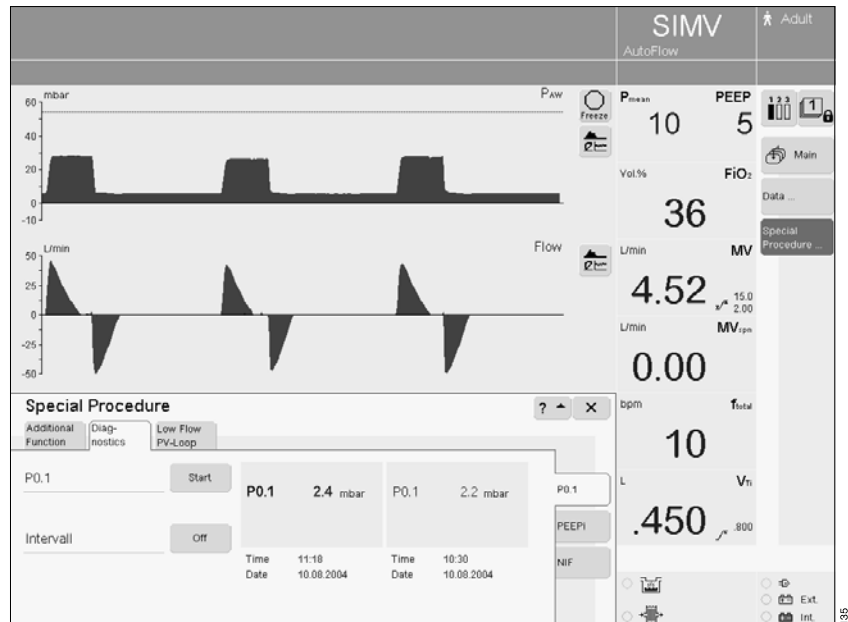

Intrinsic PEEP – PEEPi

Intrinsic PEEP* is the actual end-expiratory pressure in the lung.

Due to the dynamics of lung mechanics (resistance, compliance and closing volume) and the ventilation setting parameters, the intrinsic PEEP differs from the PEEP in the upper airways.

The Intrinsic PEEP measurement procedure also measures the trapped volume resulting from the different PEEP values, i.e. the amount of air trapped in the lungs and not taking part in the gas exchange process.

This special procedure can be performed in all ventilation modes.

Activity by the patient during this procedure can distort the measured values.

- Touch the function key »**Special Procedure...**«. EvitaXL displays the menu »**Additional Function**«.
- Touch the screen key »**Diagnostics**«.
- Touch the screen key »**PEEPi**«.

EvitaXL displays the last measured PEEPi value in larger characters with time/date in the left-hand column. The value for the previous measurement is in the right-hand column.

The set PEEP is shown with the measured values.

To start PEEPi:

- Touch the screen key »**Start**«, the key turns yellow.
- Confirm = press rotary knob, the screen key turns green and EvitaXL starts measurement of the PEEPi value.

To view additional text information:

- Touch the screen key »**? ▲**«.

To quit the menu:

- Touch the screen key »**x**«.



* For a detailed description of Intrinsic PEEP, see page 226.

Negative Inspiratory Force NIF

The Negative Inspiratory Force index (NIF)* measures the patient's maximum inhalation effort after exhaling. The patient system is closed during measurement of the NIF. This value is also known as the Maximum Inspiratory Pressure (MIP). As a result of the inhalation effort during manually extended expiration, the patient generates a negative pressure in relation to PEEP.

The probability that the patient can be weaned successfully increases with the magnitude of this negative pressure. Patients with a NIF of less than -30 mbar can in all probability be extubated successfully, while those with a NIF of up to -20 mbar will most probably prove unsuccessful.

EvitaXL determines the NIF value during manually extended expiration.

- Touch the function key »**Special Procedure...**«. EvitaXL displays the menu »**Additional Function**«.
- Touch the screen key »**Diagnostics**«.
- Touch the screen key »**NIF**«.

EvitaXL displays the last measured NIF value in larger characters with time/date in the left-hand column. The value for the previous measurement is in the right-hand column.

To measure the NIF value:

- **Touch and hold** the screen key »**Exp. Hold**«. Expiration is ended by the ventilator after max. 15 seconds.

Measurement is ended automatically by EvitaXL after max. 15 seconds.

To view additional text information:

- Touch the screen key »**? ▲**«.

To quit the menu:

- Touch the screen key »**✕**«.



* For a detailed description of NIF, see page 225. Bibliography [17], [18], page 235

Low Flow PV-Loop (optional)

EvitaXL determines the Low Flow PV-Loop* during an extended inspiration or an inspiration and expiration.

The measuring procedure can only be carried out in the »Adult« patient mode.

The measuring procedure should only be carried out on patients with no spontaneous breathing.

- Touch the function key »**Special Procedure...**«. EvitaXL displays the menu »**Additional Function**«.
 - Touch the screen key »**Low Flow PV-Loop**«.
- EvitaXL opens the information screen.

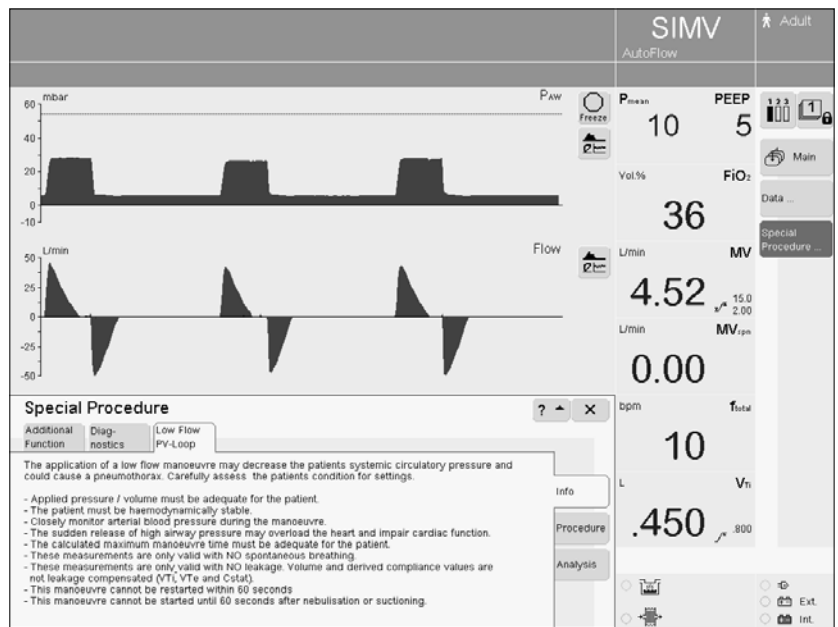

Observe the information before carrying out the measurement!

For additional information, see page 227.

The application of a low flow manoeuvre may decrease the patient's systemic circulatory pressure and could cause a pneumothorax, for example. Carefully assess the patients's condition for settings.

- Applied pressure / volume must be adequate for the patient.
- The patient must be haemodynamically stable.
- Closely monitor arterial blood pressure during the manoeuvre.
- The sudden release of high airway pressure may overload the heart and impair cardiac functions.
- The calculated maximum manoeuvre time must be adequate for the patient.
- These measurements are only valid with no spontaneous breathing.
- These measurements are only valid with no leakage. Volume and derived compliance values are not leakage compensated (VT_i, VT_e and C_{stat}).
- This manoeuvre cannot be restarted within 60 seconds.
- This manoeuvre cannot be started until 60 seconds after nebulisation or suctioning.

* Lung Protection Package option
 For a detailed description, please refer to page 227.

Measuring procedure

- Touch the screen key »**Procedure**«.
- Touch the screen key »**Pstart**«, »**Plimit**«, »**Flow**« and »**Vlimit**«, set = turn rotary knob, confirm = press rotary knob.

»**Pstart**« can be set between 0 and PEEP.

»**Plimit**« and »**Vlimit**« are limited by the alarm limits.

- Adjust the alarm limits, if necessary, see page 79.

- 1 The maximum duration of the measuring procedure »**Tmax**« is displayed.

To record both inspiration and expiration:

- Touch the screen key »**Start Insp+Exp**«, confirm = press rotary knob.

To record inspiration only:

- Touch the screen key »**Start Insp only**«, confirm = press rotary knob.

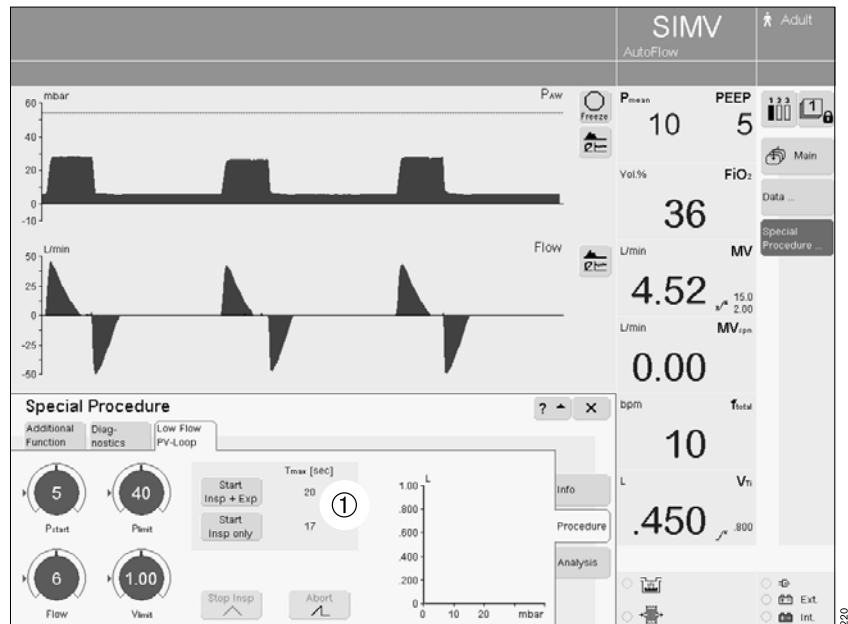

End inspiration

During the measurement »Insp+Exp«:

- Touch the screen key »**Stop Insp**«.

EvitaXL ends inspiration, expiration takes place at the set flow.

During the measurement »Insp only«:

- Touch the screen key »**Stop Insp**«.

EvitaXL ends inspiration, expiration takes place at a pressure drop of max. 5 mbar/s.

Quick abortion of the measurement

- Touch the screen key »**Abort**«, confirm = press rotary knob.

EvitaXL ends the measurement, the pressure immediately drops to the set PEEP.

The current measurement is not interrupted by calling up another screen.

Return to the screen for the measurement:

- Touch the function key »**Special Procedure...**«.
- Terminate the measurement with the »**Stop Insp**« or »**Abort**« keys.

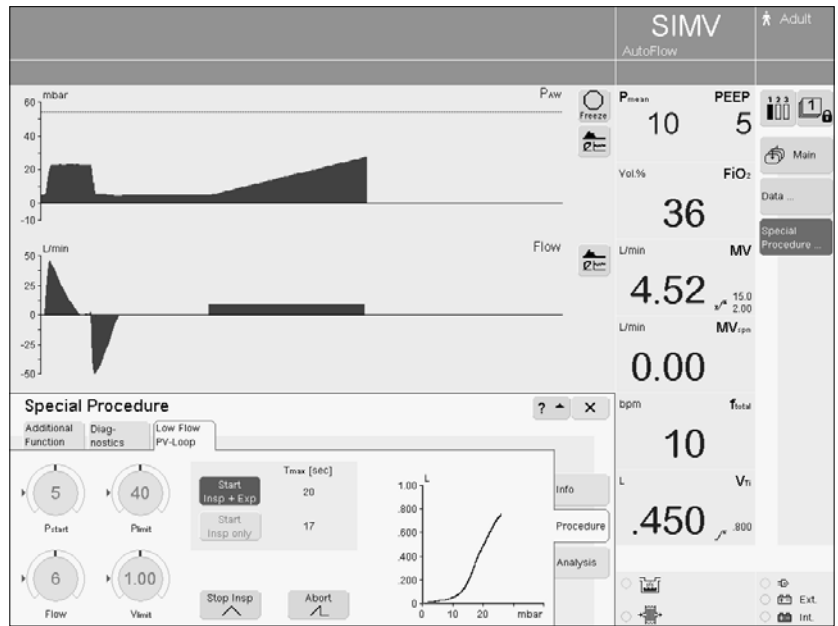

Measurement analysis

After the measurement, EvitaXL opens the »Analysis« screen.

To display a point on the curve:

- Touch the screen key »Cursor 1« or »Cursor 2«.
- Turn the rotary knob to position the cross-hair cursor over the required point; the measured values are displayed.

The light grey connecting line of the two measuring points on the inspiratory or expiratory section of the curve represents the static compliance. The values for the inspiratory and expiratory static compliance (C_{stat}), which are calculated from this, are displayed.

The measured values are not leakage compensated.

A new measurement can only be started after 60 seconds. During this time the start keys are grey and cannot be activated.

To view additional text information:

- Touch the screen key »?▲«.

To quit the menu:

- Touch the screen key »X«.

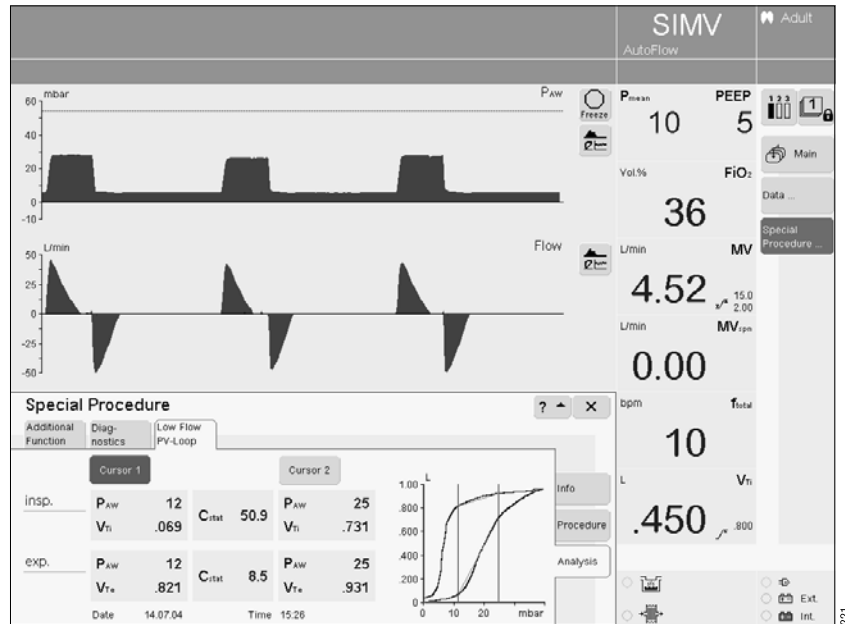

Sensors

EvitaXL uses the following sensors for measuring and monitoring:

- Flow sensor
- Pressure sensors
- O₂ sensor
- CO₂ sensor (optional)

The last sensor calibration values obtained are saved until the sensors are calibrated again, even if the ventilator is switched off in the meantime.

The pressure sensors for measuring the airway pressure are calibrated automatically.

The flow sensor and O₂ sensor are calibrated automatically once per day.

The flow sensor can be calibrated at any time, even during ventilation.

The O₂ sensor can be calibrated at any time, even during ventilation. This does not influence the applied O₂ concentration.

Calibration of the CO₂ sensor (optional) can be checked during ventilation.

Flow sensor calibration

- After replacing the flow sensor.

The flow sensor is automatically cleaned by EvitaXL before it is calibrated.

It is automatically cleaned and calibrated by EvitaXL after use of the medicament nebuliser.

- **Flammable gases (e.g. alcohol vapours after disinfection) must be avoided.**
- **Flow sensors which have been disinfected in ethanol must be allowed to dry in air for at least 30 minutes.**

- Press the key »  **Sensor Parameter**«. The menu »**Sensor Parameter**« is displayed with the »**Flow**« menu. Flow monitoring is active.

Start calibration:

- Touch the »**Start**« screen key. The key turns green and EvitaXL calibrates the flow sensor.

EvitaXL uses the next inspiration phase for the calibration process. Short inspiration times are extended to approx. 1 second.

Screen display:

Flow calibration

The screen key »**Start**« turns pale green when calibration is completed.



External flow compensation

When a constant external flow of up to 12 L/min is supplied (e.g. during medicament nebulisation with separate gas supply or during separate tracheal gas insufflation TGI), this flow can be calculated by EvitaXL and the tolerance increased for the monitoring parameters of the flow sensor in order to avoid generation of the alarm "Flow measurement inop." during these applications. The originally measured expiratory volume is maintained: EvitaXL measures a correspondingly higher value for V_{Te} and MV. The value shown for V_{Ti} is too low. The tidal volume actually applied to the patient during volume-controlled ventilation is higher than that set. Pressure-controlled ventilation is therefore recommended in combination with an external flow.

In order to avoid false alarms and ensure monitoring:

- Adjust both alarm limits for MV in line with the actual value.
- Use additional monitoring, e.g. SpO₂, if necessary.

For initial calculation of the external flow:

- Start external flow.

In the »Flow« menu:

- Touch screen key »measure«, the key turns yellow. EvitaXL measures the external flow and displays it in the menu with the date and time.

The following message is displayed while measurement is in progress:

Measuring external flow

Calculation of the external flow is interrupted by EvitaXL if it exceeds 12 L/min or if the flow measurement function is defective.

When the external flow has been calculated successfully, it is taken into account automatically and the screen key »On« appears in green.

If an external flow is not applied:

- Touch the screen key »Off«, the key turns yellow.
- Confirm = press rotary knob, the key turns pale green.

Once the external flow has been calculated by EvitaXL, it can be taken into account at any time:

- Touch the screen key »On« in the »Flow« menu, the key turns yellow.
- Confirm = press the rotary knob, the key turns green.

If the external flow changes:

- Touch the screen key »measure« again and the new external flow is calculated by EvitaXL.



O₂ sensor calibration

- After replacing the O₂ sensor (wait 15 minutes for the O₂ sensor to warm up).
- When the measured and set values diverge by more than 2 % by volume.

The O₂ sensor can be calibrated during ventilation.

- Press the key »  **Sensor Parameter**«.
- Touch the screen key »O₂«. EvitaXL displays the menu »O₂«.

Start O₂ calibration:

- Touch the »**Start**« screen key. The key turns green and EvitaXL calibrates the O₂ sensor.

Screen display:

O₂ calibration active

The screen key »**Start**« turns pale green when calibration is complete.



Zero/check/calibrate CO₂ sensor

(if Capno Plus option is installed)

The CO₂ sensor is works-calibrated and can be used without further calibration on any EvitaXL unit.

Before measurement and when transferring the sensor to another EvitaXL unit, the zero indication should be checked with the sensor on a clean park bracket and zero calibration performed if necessary.

CO₂ zero calibration is performed as part of the device check. However, zero calibration can also be performed manually at any time.

There must not be any increased CO₂ concentration between the windows of the park bracket when checking the zero indication or performing zero calibration. In other words only the background concentration of approx. 0.4 Torr or 0.05 % by volume normally present in rooms may be present.

For this reason:

- Do not breathe onto the park bracket when checking the zero indication or performing zero calibration.

The calibration (sensitivity) of the sensor can be roughly checked with the test filter attached to the sensor lead; it can be checked more precisely with calibration gas.

Calibration must be checked with calibration gas:

- if the result of testing with the test filter is unsatisfactory,
- but at least every six months in conjunction with the device inspection.

Recalibration of the sensor is only required if the specified calibration values are not met when testing calibration with the calibration gas.

Zero calibration on the park bracket, testing of the calibration with test filter or calibration gas and recalibration of the sensor can all be performed during ventilation.

Error messages relating to CO₂ measurement can be found in the chapter "Fault – Cause – Remedy" on page 144.

Notes concerning the alarm »CO₂-Sensor? !!!«:

If the alarm »CO₂-Sensor? !!!« is displayed although the sensor is connected and the cuvette is fitted, the windows on the park bracket or sensor may be soiled:

- Perform zero calibration with a cleaned park bracket and cleaned sensor.

If the dirt on the park bracket cannot be removed:

- Perform zero calibration with a clean cuvette – particularly with clean windows – in room air, taking care not to breathe in the direction of the cuvette.

Notes concerning the alarm »CO₂ zero? !!!«:

If the alarm »CO₂ zero? !!!« is displayed during measurement or if incorrect measured values are suspected, e.g. etCO₂ values too low or inspiratory values too high:

- Check whether the cuvette windows are soiled: clean the cuvette if necessary or use a different, clean cuvette.

Despite design measures to minimise the zero shift, major soiling of the cuvette windows, e.g. with deposits due to medication nebulisation, may result in a zero shift with incorrect CO₂ measured values long before the alarm »Clean CO₂ cuvette !!!« appears due to excessively low intensity of the measuring light.

If the alarm »CO₂ zero? !!!« does not subsequently disappear or if the measured values remain suspect:

- Perform zero calibration on the park bracket.

If the measured values are still suspect:

- Perform zero calibration on a clean cuvette in room air, taking care not to breathe in the direction of the cuvette, and continue measurement with the cuvette used for zero calibration.

Notes concerning the message »CO₂-cal./-zero/-check impossible«:

If the message »CO₂-cal./-zero/-check impossible« appears after pressing the screen key »Start«, »Filter Check«, »Gas Check« or »Calibration« either:

- the CO₂ sensor has not been plugged in,
- connect CO₂ sensor
- or
- the CO₂ sensor is defective,
- replace CO₂ sensor
- or
- the CO₂ electronics in EvitaXL are defective,
- call DrägerService.

CO2 zero calibration

Only possible with a clean park bracket and clean sensor!

- Switch on EvitaXL and wait at least 3 minutes for the CO2 sensor to complete its warm-up phase.

After at least three minutes, the measured values will be inside the specified tolerance range.

- Press the key »  **Sensor Parameter**«.
 - Touch the screen key »CO2«.
- EvitaXL displays the menu for »CO2«.

Start zero calibration:

- Touch screen key »Start«, it turns dark green.

Screen display:
Park CO2 sensor



- 1 Remove CO2 sensor from the cuvette and

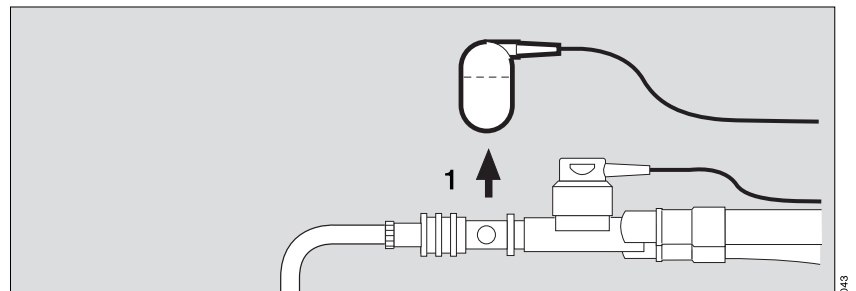

- 2 place the sensor on its park bracket; do not breathe onto the park bracket.

- Confirm with rotary knob.
- CO2 zero calibration is now performed by EvitaXL.

Display:
CO2 zero calibration

After approx. 5 seconds, EvitaXL confirms with the message:

CO2 zero ok

- 1 Fit the sensor back on the cuvette.

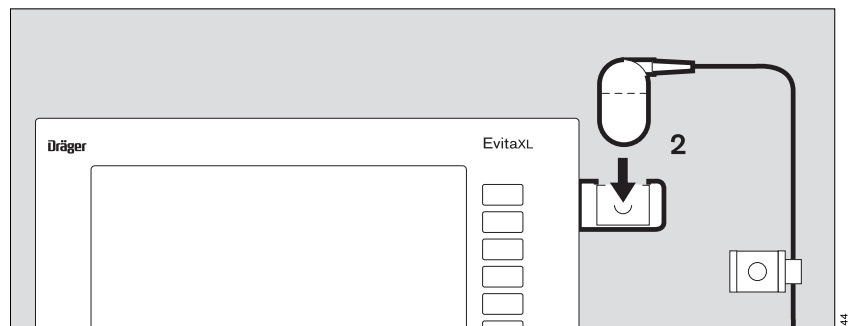

Incorrect zero calibration is indicated by the EvitaXL with the following message:

CO₂ zero?

- Repeat CO₂ zero calibration.

If zero calibration is still impossible:

- Check whether the park bracket or sensor is soiled and clean it if necessary.

If the sensor is defective:

- Replace sensor and repeat zero calibration.

Checking CO₂ calibration with test filter

Use the test filter on the cable of the CO₂ sensor.

- Switch on EvitaXL and wait at least 3 minutes for the CO₂ sensor to complete its warm-up phase.

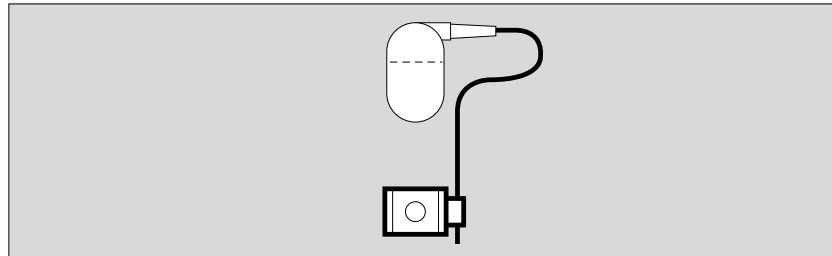

- First perform CO₂ zero calibration, page 111, then:

in the menu »CO₂«:

- Touch the screen key »Check sensor«.
- Touch the screen key »Filter Check«.



- Place the test filter in the CO2 sensor.

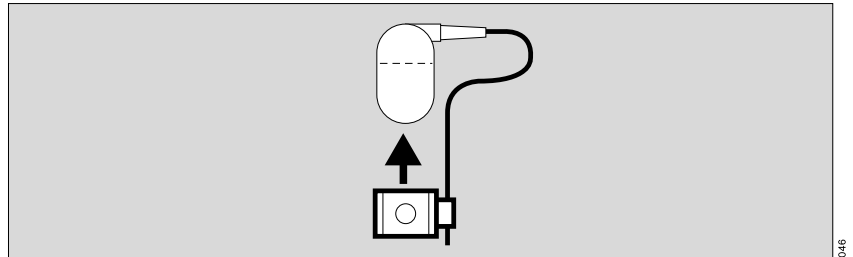

EvitaXL displays the test value of the CO2 concentration FCO2 in the menu, example:

FCO2 4.0 Vol.%

This value must agree to within ± 0.3 Vol.% with the specification on the test filter.

Example: 4.1 Vol.% on the filter:
permitted value range: 3.8 to 4.4 Vol.%

If the test value is outside the permitted tolerance, the test gas must be checked or calibrated.

- Push CO2 sensor back on the cuvette.

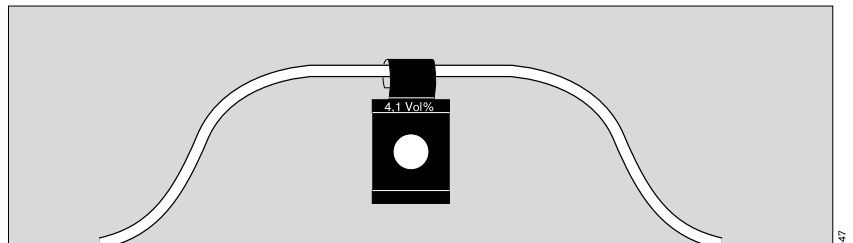

Checking CO2 calibration with calibration gas

- if the specified calibration value was not met when testing with the test filter
- at least once per half-year.

Calibration gas containing N2O must not be used!

- Switch on EvitaXL and wait at least 3 minutes for the CO2 sensor to complete its warm-up phase.

- First perform CO2 zero calibration, page 111, then:

in the menu »CO2«:

- Touch the screen key »**Check sensor**«.



- Connect the calibration gas supply.
Use the cuvette from the calibration set!
- 1 Connect the calibration gas cylinder and the cuvette of the calibration set to the hose.
 - 2 Remove the CO₂ sensor from its park bracket and fit it to the cuvette of the calibration set.
 - 3 Read the CO₂ and O₂ concentration (if applicable) of the calibration gas from the calibration gas cylinder.

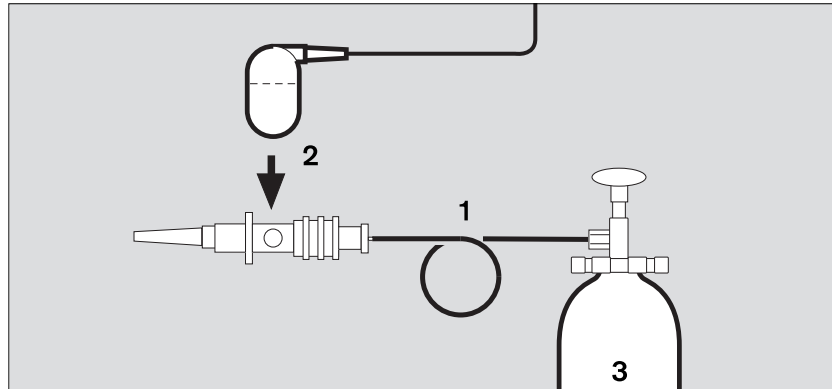

Enter these concentration values with the screen knobs.

- Touch the screen knob.
Enter the concentration
= turn rotary knob,
confirm = press rotary knob.

If the calibration gas comprises CO₂, O₂ and N₂:

- Enter the O₂ concentration read off.

If the calibration gas only comprises CO₂ und N₂:

- Set the O₂ concentration to »0.«.

- Touch the screen key »Gas Check«. EvitaXL displays the CO₂ concentration FCO₂ in the menu.
Example: **FCO₂ 5.0 Vol.%**.

After about 10 seconds, the value of FCO₂ must match to within ± 0.2 Vol.% the CO₂ content of the calibration gas.

If the calibration value is outside the permitted tolerance, the CO₂ sensor must be recalibrated with test gas.

- Push CO₂ sensor back on the cuvette.



Calibrating the CO₂ sensor

- If the check values are not met on checking the calibration using calibration gas.

Calibration gas containing N₂O must not be used!

- Switch on EvitaXL and wait at least 3 minutes for the CO₂ sensor to complete its warm-up phase.

- First perform CO₂ zero calibration, page 111, then:

In the menu »CO₂«:

- Touch the screen key »Calibration«.
- EvitaXL displays the »Calibration« menu.

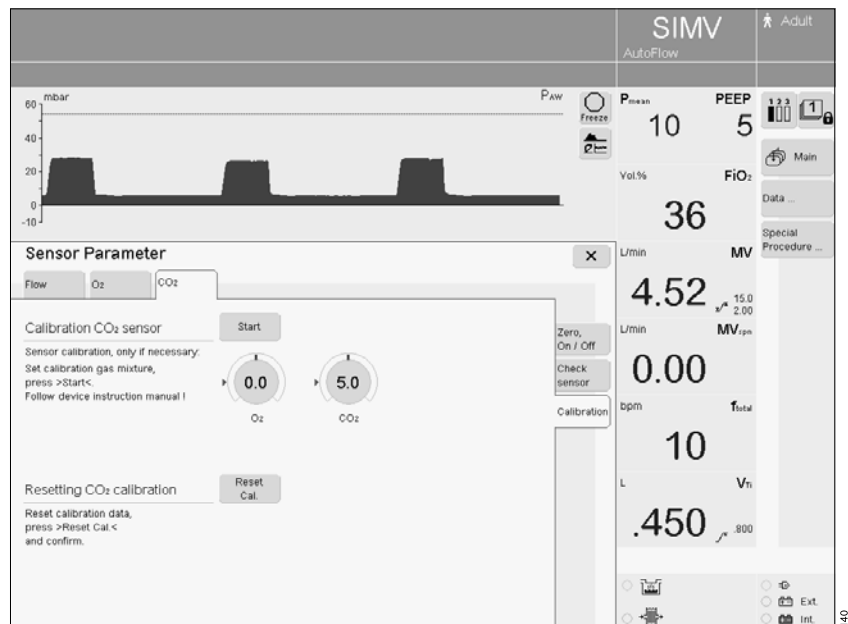

- Connect the calibration gas supply. Use the cuvette from the calibration set!

- 1 Connect the calibration gas cylinder and the cuvette of the calibration set to the hose.
- 2 Remove the CO₂ sensor from its park bracket and fit it to the cuvette of the calibration set.
- 3 Read the CO₂ and O₂ concentration (if applicable) of the calibration gas from the calibration gas cylinder.

Enter these concentration values with the screen knobs.

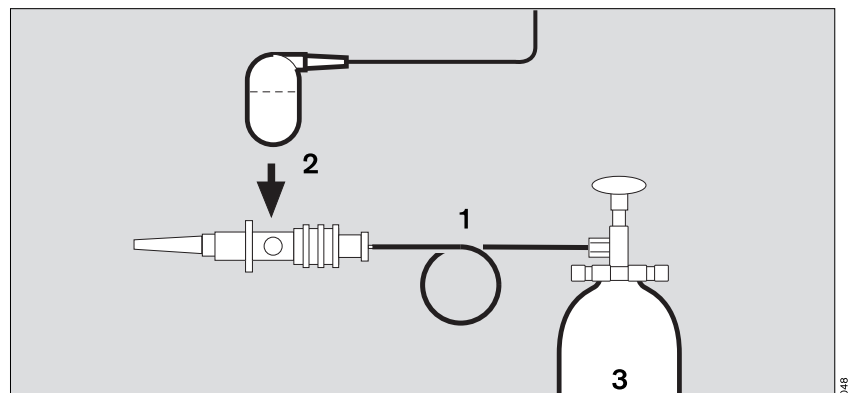

- Touch the screen knob.
- Enter the concentration = turn rotary knob, confirm = press rotary knob.

When using the standard calibration gas (5 Vol.% CO₂ and 95 Vol.% N₂):

- Set O₂ concentration to »0«, CO₂ concentration to »5«.

- Touch the »Start« screen key.

During calibration, the following message is displayed on the screen:

CO₂ calibration. Please wait

EvitaXL carries out calibration and confirms with the message:

CO₂ calibration ok

Failed calibration is indicated by the ventilator with the message:

CO₂ calibration interrupted

or

CO₂ calibration not ok

- Repeat the calibration of the CO₂ sensor.

If calibration still proves impossible, the CO₂ concentration value entered may not be the same as that in the cylinder:

- Check CO₂ value entered,

or

calibration gas cylinder is empty:

- Use a new calibration gas cylinder

or

sensor is defective:

- Replace sensor.



140

Resetting CO2 calibration

- If calibration was not successful or if there were problems during calibration, the sensor can be reset to the factory reset values.

In the menu »CO2«:

- Touch the screen key »Calibration«.
- Touch the screen key »Reset Cal.«.

The calibration is reset by EvitaXL after approx. 5 seconds and the factory-set calibration value is now effective again.

- Recover the correct calibration as soon as possible!

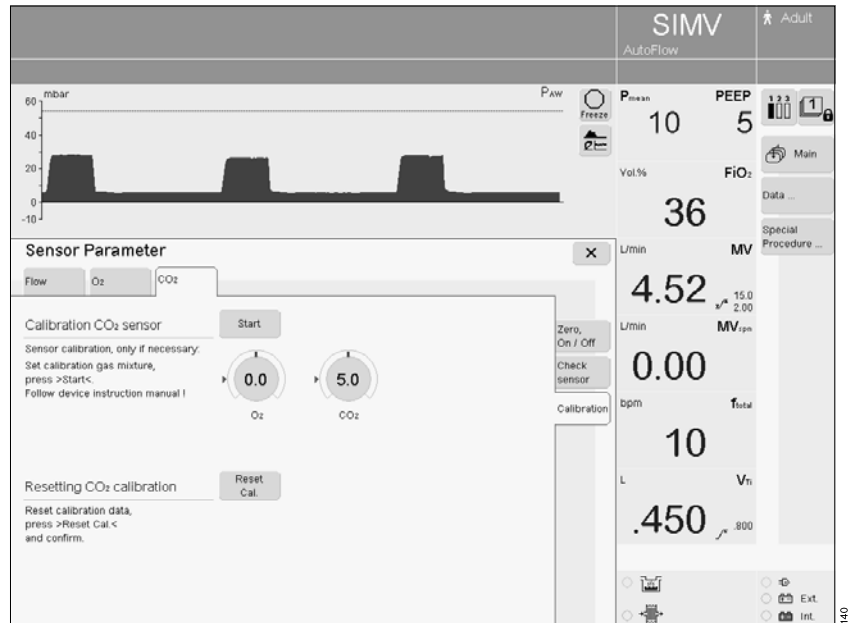

Switching off the monitor functions

For example, if a spent sensor cannot be replaced.

- **Ensure appropriate replacement monitoring function without delay and replace spent sensor!**

The O₂ monitoring function can be replaced by an adequate replacement monitoring function. The O₂ alarm limits of the replacement monitoring function must be set in accordance with the FiO₂ setting:

FiO₂ <60 Vol.% → O₂ ±4 Vol.%

FiO₂ ≥60 Vol.% → O₂ ±6 Vol.%

The expiratory flow monitoring function cannot be fully replaced by a replacement monitoring function. The MV alarm limits of the replacement monitoring function must be set accordingly.

The ventilation functions and ventilation monitoring are only possible to a limited extent without the expiratory flow sensor. A spent or disconnected expiratory flow sensor can lead to deviations in the minute and tidal volumes or cause self-triggers.

- Press the key »  **Sensor Parameter**«.
- EvitaXL displays the menu »**Sensor Parameter**«.
- Touch the screen key for the sensor to be switched off, e.g. »CO₂«.
- Touch the screen key »Off«, the key turns yellow.
- Confirm = press the rotary knob, the key turns green.

The values measured by the sensor concerned disappear.
The corresponding alarm function is deactivated.

After replacing the sensor:

- Switch the monitor function back on.



Selecting Standby Mode

- To perform the device check.
- To keep EvitaXL ready for operation while the patient is absent.
- To change the patient mode.
- For the O₂ therapy (optional).

Ventilation does not take place in standby mode!

- Press the key » **Start/Standby**« and keep it depressed for 3 seconds.

The ventilator is now in standby mode.

Or

- Press the key » **Start/Standby**«. EvitaXL displays the menu »**Start/Standby**«.

- Touch screen key »**Standby**«.

- Confirm = press the rotary knob, the key turns green.

- 1 Touch the screen key »**Alarm Reset**« in the field for alarm messages at the top of the screen.

- Confirm = press the rotary knob, the key turns green.

The ventilator is now in standby mode.

If the patient mode or ideal body weight is changed in standby mode, new values will be calculated by EvitaXL for starting ventilation, see page 47.



Terminating Standby Mode

– To continue ventilation.

- Press the key » **Start/Standby**«. EvitaXL starts ventilation.

Or

- Touch the screen key »**Start**«, the key turns yellow.
- Check the settings.
- Confirm = press rotary knob, the menu disappears and is replaced by the main screen. EvitaXL starts ventilation.

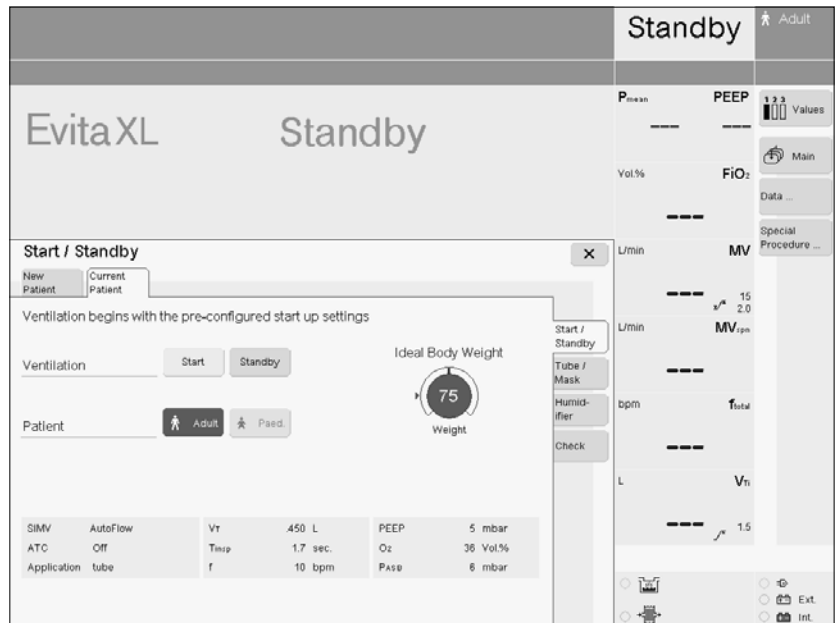

O2 Therapy (optional)

During the O2 Therapy, the monitoring functions of EvitaXL are restricted. Monitoring of SpO2 and the pulse frequency is only available with the appropriate option.

Only use oxygen masks for the O2 Therapy. Do not use masks for non-invasive ventilation (NIV).

FiO2, SpO2 and the pulse frequency are monitored during the O2 Therapy.

The airway pressure and expiration-dependent parameters such as flow, minute volume or apnoea are not monitored.

Use SpO2 monitoring for patients who are dependent on an increased defined O2 concentration.

O2 Therapy preparation

The software is installed ready for use by specialists before initial operation.

Connecting ventilation hoses

Do not use antistatic or conductive hoses*.

Depending on the desired position of the ventilator in relation to the bed, the hinged arm can be fitted to either side of the machine.

For adults with Aquapor EL breathing gas humidifier

- 1 Hang the hinged arm on the rail and tighten the screws.
- 2 Fit the ventilation hoses for inspiration. Check the hose lengths (metres).
- 3 The expiration ports on EvitaXL and on the Y-piece remain open!
- 4 Fit the water trap in the vertical position.

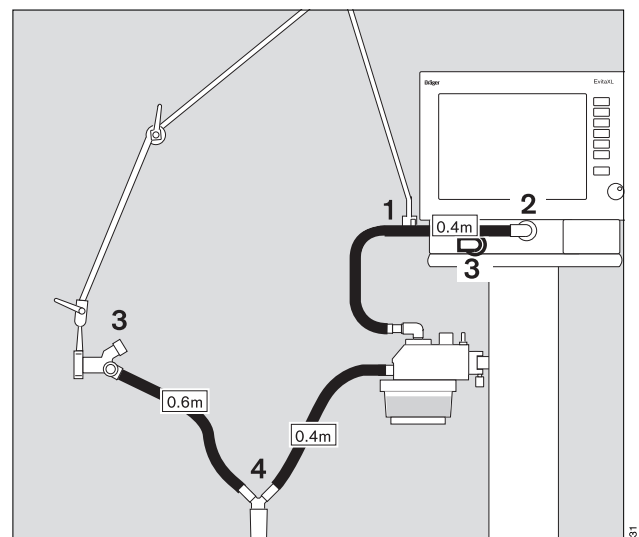

* DIN VDE 0750 section 215:
The use of anti-static or electrically conductive material in the breathing system of the lung ventilator is not considered conducive to greater safety. On the contrary, the use of these materials increases the danger of electric shock to the patient and of fire due to the presence of oxygen.

For adults or infants with Fisher & Paykel MR 850 breathing gas humidifier

- 1 Hang the hinged arm on the rail and tighten the screws.
- 2 Fit the ventilation hoses for inspiration. Check the hose lengths (metres).
- 3 The expiration ports on EvitaXL and on the Y-piece remain open!

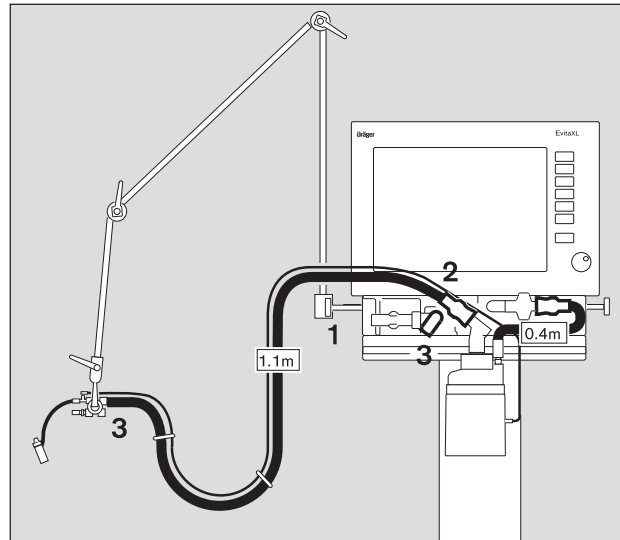

- Fit the temperature sensor, see page 27.
- Switch on EvitaXL, see page 45.
- Switch EvitaXL to standby, see page 119.
- Switch on monitor function, see page 118.
- Set alarm limits, see page 79.

Parameter	Setting range
✓ SpO ₂ (optional)	51 to 100 %
± SpO ₂ (optional)	50 to 99 %
✓ Pulse frequency (optional)	21 to 250 bpm
± Pulse frequency (optional)	20 to 249 bpm

The inspiratory breathing gas temperature has a fixed upper alarm limit of 40 °C.

The alarm limits for MV, f_{spn}, VT_i, PAW, T_Apnoea are not active.

Switching on O₂ Therapy

- Touch the screen key »Oxygen Therapy«.

Set O₂ and flow

- Touch the appropriate screen knob.
- Adjust to the desired value = turn rotary knob.
- Confirm setting = press rotary knob.

- Touch screen key »On«, confirm = press rotary knob.

O₂ Therapy is switched on.

EvitaXL must only be used under the supervision of qualified medical staff, so that help is immediately available if malfunctions occur or the patient has insufficient spontaneous breathing.

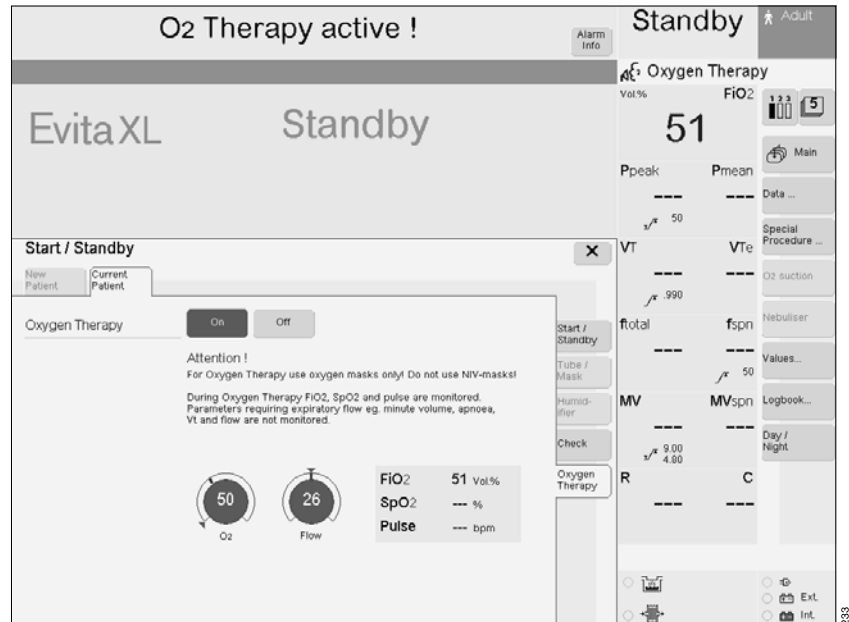

Switching off O₂ Therapy

- Touch the screen key »Oxygen Therapy«.
- Touch the screen key »Off«, confirm = press rotary knob.

O₂ Therapy is switched off.

Configuration

Configuration	126
Specific system settings	126
Specific initial therapy values	137

Configuration

For setting specific parameters for the system or therapy. These initial (default) values are effective when the ventilator is switched on.

Specific system settings

- Press the key » System Setup«. EvitaXL displays the menu »System Setup«.
- The »System« menu is displayed automatically with an overview of the parameters which can be set as initial values.



Adjust the alarm volume

- Press the key » System Setup«.
- Touch the screen key »Sound, Day/Night«. The EvitaXL displays the menu for adjusting the volume and the day/night screen brightness.
- Touch the screen key on the »Alarm Volume« line.
- Set the volume = turn rotary knob, confirm = press rotary knob.

Adjust volume of the acoustic alarm so that an alarm cannot be overheard!



Day/night function for screen brightness

- Press the key » System Setup«.
- Touch the screen key »Sound, Day/ Night«.

Two options are available: »Day« for good contrast and bright colours and »Night« for reduced screen brightness.

- Touch the screen key »Day« or »Night«, the selected key turns green and the corresponding option is effective.



Display curves, loops, trends

- Press the key » System Setup«.
- Touch the screen key »Screen«. EvitaXL displays the menu »System Setup«.

- Touch the screen key »Graphics...«.
- To select graph 1, 2 or 3:

- Touch the corresponding key in line »Graphic 1«, »Graphic 2« or »Graphic 3«. The key turns yellow and the selection list is displayed.
- Select and confirm the parameter with the rotary knob.



Define initial measured values

- Press the key » System Setup«.
- Touch the screen key »Screen«.
- Touch the screen key »Values...«.

EvitaXL displays the menu for compiling the selection of essential measured values and their effective alarm limits. The screen keys are arranged in the same order as the numerical values on the main screen.

Three sets with six values each can be combined.

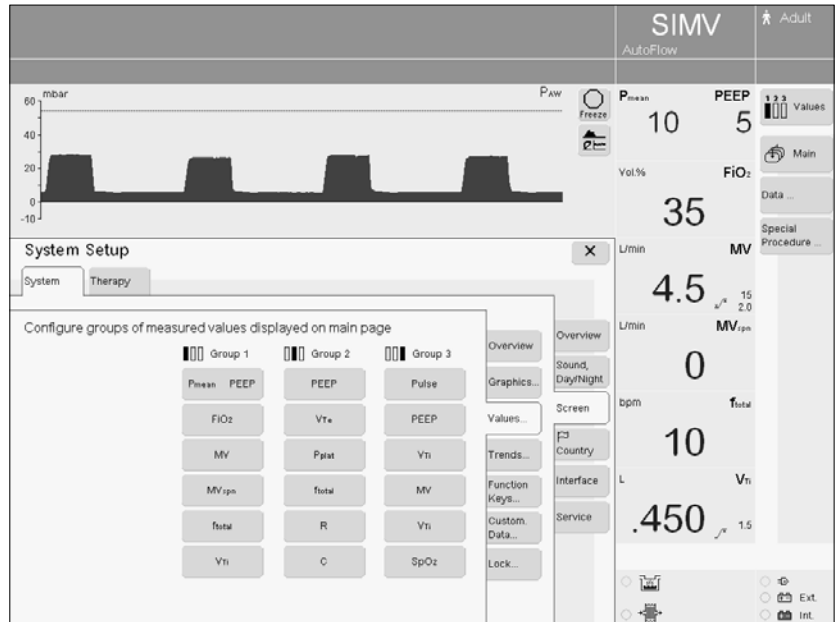

For specific selection of the three sets:

- Touch the screen key for the line concerned in the relevant option (Group 1, Group 2 or Group 3). The key turns yellow.

An additional menu is displayed:

- For selecting one or two parameters.
- For selecting any parameter.

- Select one or two parameters per line = touch screen key »1 Value« or »2 Values«.
- Select parameter from the list = turn rotary knob, confirm = press rotary knob.

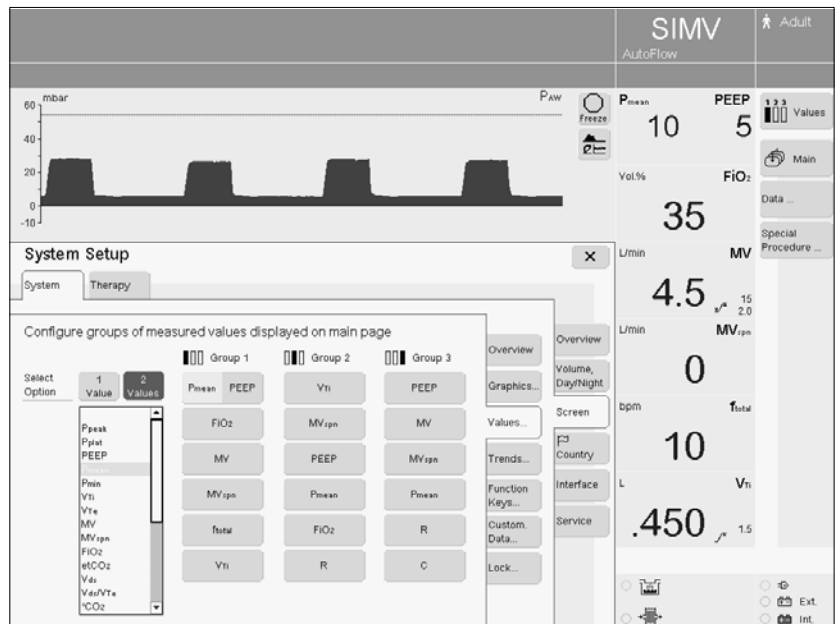

Define the trends to be recorded

- Press the key » **System Setup**«.
- Touch the screen key »**Screen**«.
- Touch the screen key »**Trends...**«.

EvitaXL displays the menu for selecting the measured values for the trend display. Up to eight measured values can be selected, depending on the options available. Only the selected measured values are saved as a trend.

Touch the screen key for the first measured value. The key turns yellow and the selection list is displayed.

- Select and confirm with the rotary knob.

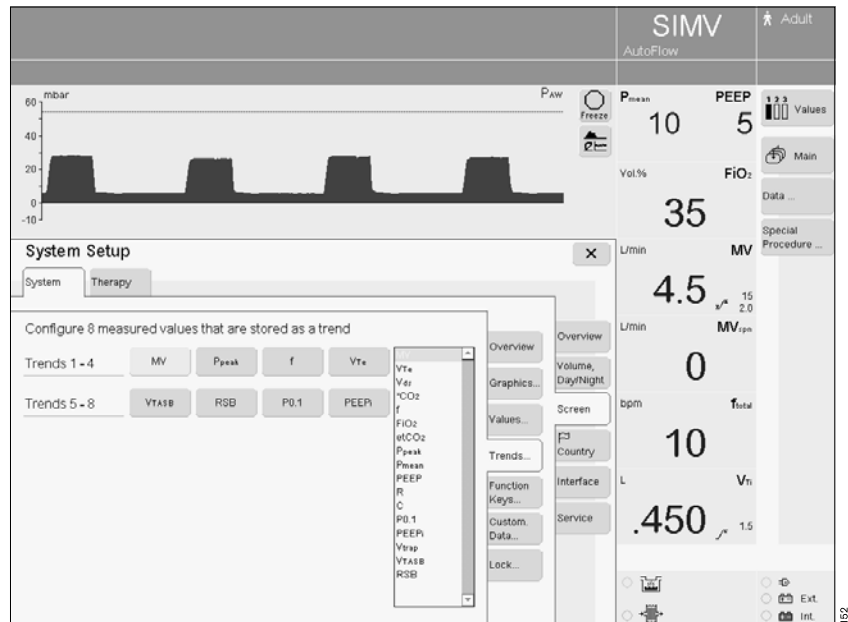

Screen function key assignment

Seven additional on-screen function keys can be defined for accessing a function directly instead of via a menu.

- Press the key » **System Setup**«.
- Touch the screen key »**Screen**«.
- Touch the screen key »**Function Keys ...**«.

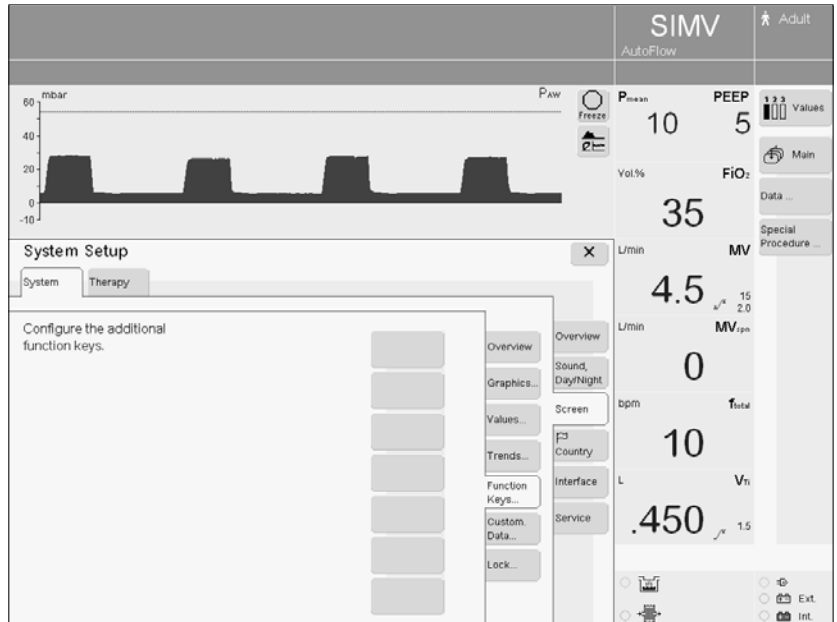

EvitaXL displays the menu for defining seven additional function keys.

- Touch the new key to be defined, it turns yellow. A selection list is displayed alongside the keys.
- Select and confirm with the rotary knob.

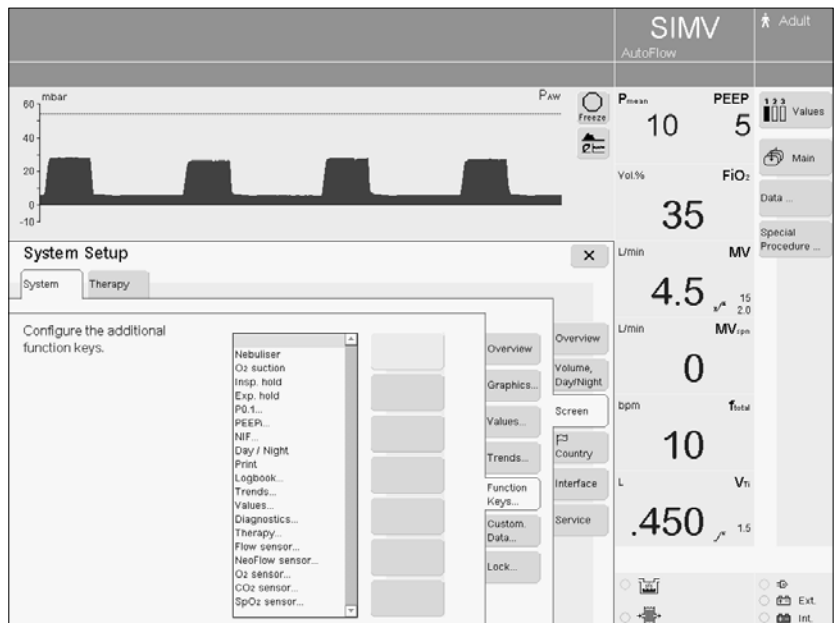

Define customised values and settings

- Press the key » System Setup«.
- Touch the screen key »Screen«.
- Touch the screen key »Custom. Data...«.
- Touch the screen key »Measured Values«.

EvitaXL first displays the menu for compiling the customised table of measured values.

Up to 18 measured values can be compiled. The screen keys reflect the position and order of the measured values in the customised table.

- Touch each successive screen key. It turns yellow and a selection list appears beside the keys.
- Select and confirm with the rotary knob.

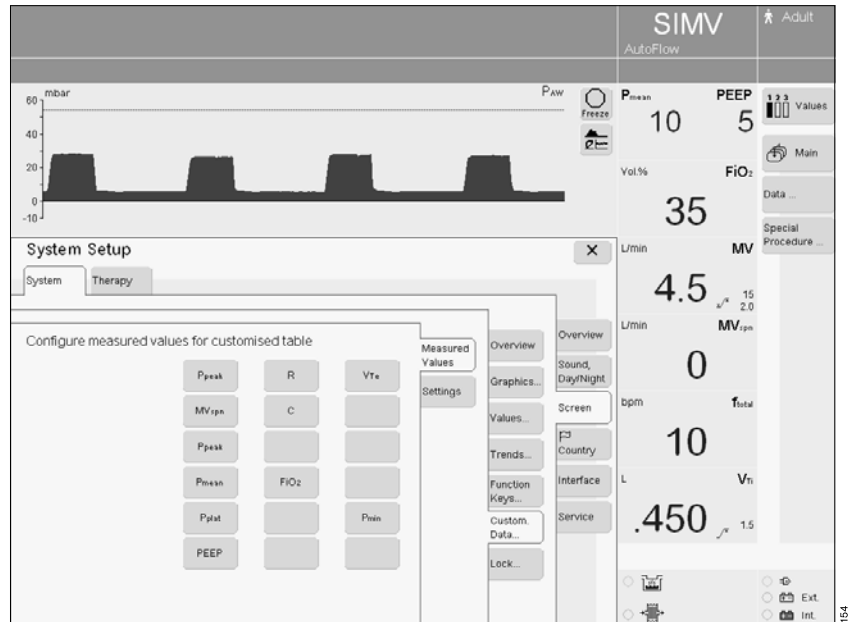

To configure the settings:

- Touch the screen key »Settings«. The unit displays a table with max. 15 settings.
- Configure the settings as described above for the measured values.

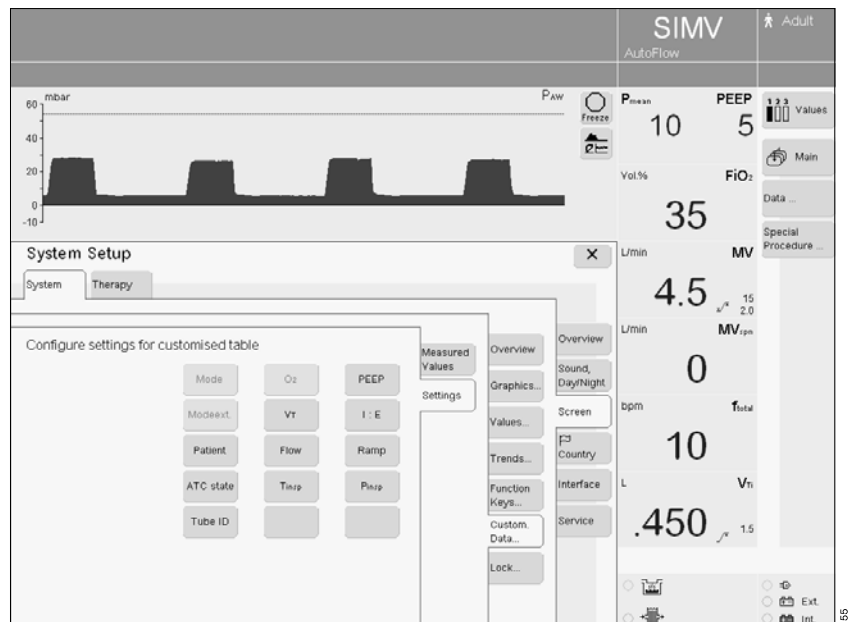

Screen configurations

The following areas of the screen configuration are stored:

- Curves, loops, trends or short trends displayed on the main screen
- 3 sets of measured values
- Function keys
- Customised data table

Changes in the configuration of the trends have an effect on the trends stored in the screen configuration.

6 different screen configurations are available.

Works setting for the screen configuration, see page 229.

Display screen configuration

On the main screen:

- Touch the screen key »« until the required screen configuration is displayed.

Fast changeover to the required screen configuration:

- Touch the screen key »« several times until the required screen configuration is displayed.

Set screen configuration

- Press the key » System Setup«.
- Touch the screen key »Screen«.
- Touch the screen key »View...«.

Save the current screen configuration



- Touch the screen key »«.
- Confirm = press rotary knob.

Or on the main screen:

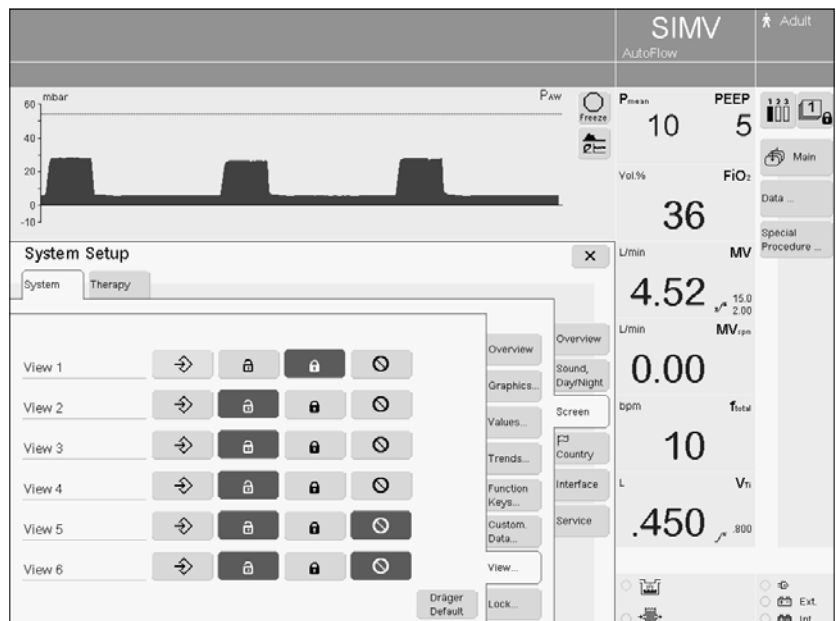
- Keep the screen key »« depressed for 3 seconds, the key turns yellow.
- Select and confirm a memory location with the rotary knob.



Lock the screen configuration against overwriting

- Touch the screen key »  «.
- 1 The symbol »  « appears next to the display of the locked screen configuration.
- To deactivate the lock = touch the screen key »  «.

Masking out the screen configuration

- Touch the screen key »  «.
- The screen configuration which has been masked out is not displayed in the selection.

If the screen configuration set at the works is to be displayed:



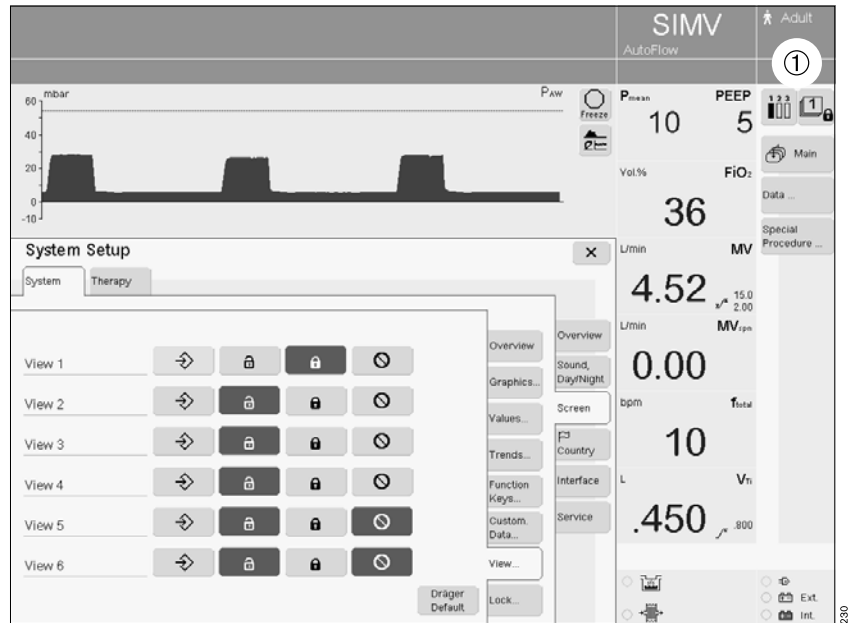

- Touch the screen key »**Dräger Default**«.
- Confirm = press rotary knob.



Lock direct access to settings

This function is used to prevent parameter settings being changed directly via the row of screen knobs.

They can still be adjusted via the key »  Ventilator Settings«.

- Press the key »  System Setup«.
 - Touch the screen key »Screen«.
 - Touch the screen key »Lock...«.
 - Touch the screen key »  «.
- The symbol »  « appears at the bottom of the main screen in the row of screen knobs.
- To deactivate the lock = touch the screen key »  «.

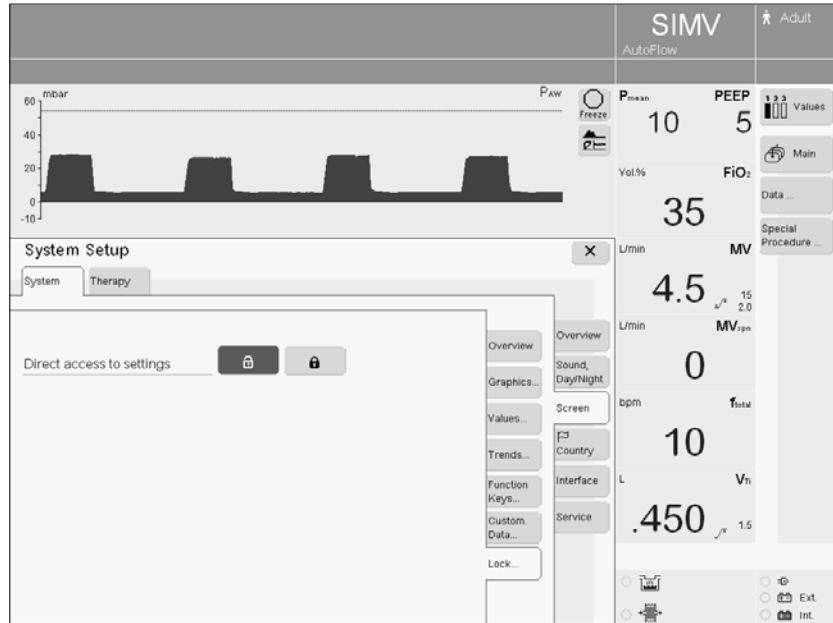



Select display language

The following languages can be selected:

- | | |
|------------|---------|
| German | Italian |
| English | Swedish |
| US English | Dutch |
| French | Russian |
| Spanish | Chinese |
| Portuguese | |

EvitaXL is factory set to the customer's own language.

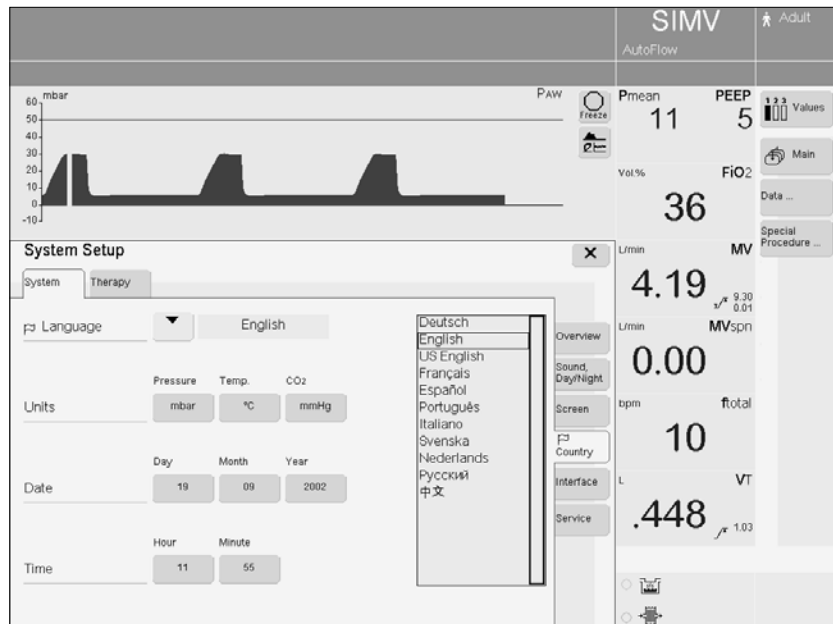

To select a different language:

- Press the key »  System Setup«.
 - Touch the screen key »  Country«.
- The current language is displayed in the field »Language«.
- Touch the screen key »  « and a selection list is displayed.
 - Select and confirm the new language with the rotary knob.





Select units

Specific national units can be selected for the physical parameters pressure, temperature and CO₂.

- Press the key » **System Setup**«.
 - Touch the screen key »  **Country**«.
- The current units are displayed in the field »Units«.
- Touch the screen key for the corresponding unit.
 - Select and confirm the unit with the rotary knob.



Select date and time

- Press the key » **System Setup**«.
 - Touch the screen key »  **Country**«.
- The current date and time are displayed in the fields »Date« and »Time«.
- Touch the screen key.
 - Set and confirm with the rotary knob.



Set interface

- Press the key » System Setup«.
 - Touch the screen key »Interface«.
- The interface parameters are displayed in the field »COM 1«.
- Touch the screen key for the required interface parameter.
 - Set and confirm with the rotary knob.



Service Diagnosis

To display the operating status of the internal function elements.
 Only available to authorised personnel with corresponding password.

Specific initial therapy values

- Press the key » **System Setup**«.
- Touch the screen key »**Therapy**«. EvitaXL displays the menu »**System Setup**« with an overview of the specific therapy parameters which can be set as initial values.

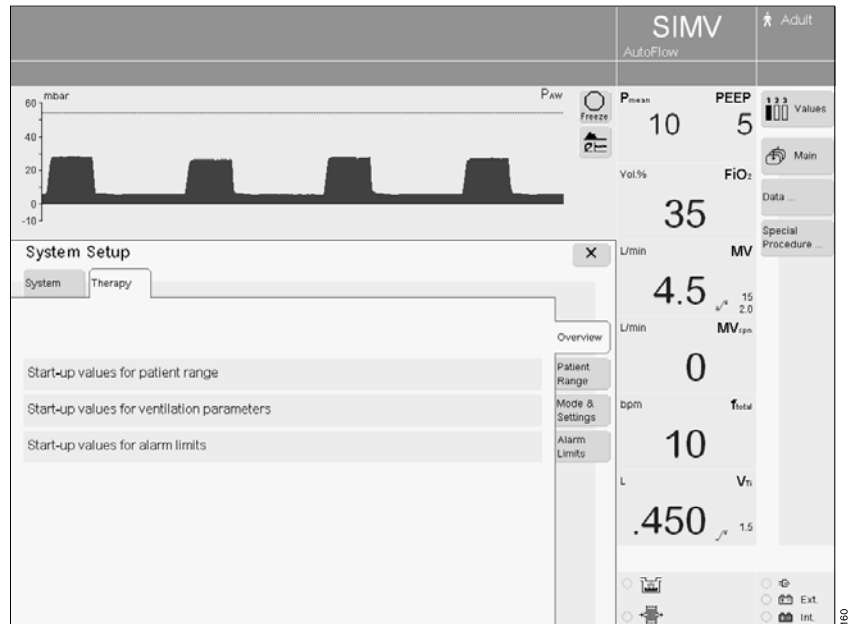

Set patient range

In the menu »**System Setup**«, »**Therapy**«.

- Touch the screen key »**Patient Range**« and enter the access code 3032.
- The numerals must be touched in the correct order.

EvitaXL displays the menu for setting the patient mode effective when the ventilator is switched on.

EvitaXL displays the last patient mode set.

"Adults or Pediatrics" is set as default.

- Touch the screen key »▼« and a selection list is displayed.
- Select and confirm a patient mode with the rotary knob.



Select start-up value for ventilation mode

- Press the key » **System Setup**«.
- Touch the screen key »**Therapy**«.
- Touch the screen key »**Mode & Settings**« and enter the access code 3032.

EvitaXL first displays an overview of the configurable parameters.

- Touch the screen key »**Modes...**«.
- Four ventilation modes are displayed in the line »**Modes**«.

The "Startup" key on the left shows the mode effective on starting and is followed by three keys for other ventilation modes.

To select the initial ventilation mode:

- Touch the screen key marked "Startup".
- EvitaXL displays a list of possible ventilation modes.
- Select and confirm with the rotary knob.

Other ventilation modes can be defined for the remaining three screen keys in the same way.



Set initial values for VT and f...

These are set in accordance with the

- patient mode
(adult or paediatric)
- weight.
- Press the key » System Setup«.
- Touch the screen key »Therapy«.
- Touch the screen key »Mode & Settings« and enter the access code 3032.
- Touch the screen key »VT, f...«.

VT, f dependent on the weight:

- Touch the screen key »By Weight«.
- EvitaXL displays the VT, f and Flowtrigger values for different weights.

In the line »Start-up by weight«:

- Touch the screen key »On« and confirm with the rotary knob.

Set values:

- Touch the corresponding screen keys for VT, f and Flowtrigger.
- Set and confirm with the rotary knob.



VT, f dependent on the patient mode:

- Touch the screen key »By Patient«.
- EvitaXL displays the VT, f and Flowtrigger values for adults and children.

In the line »Start-up by patient«:

- Touch the screen key »On« and confirm with the rotary knob.

Set values:

- Touch the corresponding screen keys for VT, f and Flowtrigger.
- Set and confirm with the rotary knob.



To restore the manufacturer's default settings:

- Touch the screen key »Dräger Default«.
- Confirm = press rotary knob.

Set initial values for O₂, I:E, pressure...

- Press the key » System Setup«.
- Touch the screen key »Therapy«.
- Touch the screen key »Mode & Settings« and enter the access code 3032.
- Touch the screen key »O₂, I:E, pressure...«

EvitaXL displays the values used for pressure, O₂ and I:E.

In the respective lines:

- Touch the corresponding screen key.
- Set and confirm with the rotary knob.

In addition to the ventilation parameters VT and f, EvitaXL also displays a table with the parameters inspiration time T_i and Flow derived from the ratio of inspiration to expiration time I:E.

To restore the manufacturer's default settings:

- Touch the screen key »Dräger Default«.
- Confirm = press rotary knob.



Define start-up values for special functions

To define the following start-up values:

- AutoFlow on/off
- Apnoea ventilation on/off
- Leakage compensation on/off

- Press the key » System Setup«.
- Touch the screen key »Therapy«.
- Touch the screen key »Mode & Settings« and enter the access code 3032.
- Touch the screen key »Add. settings...«.
- Touch the corresponding screen key to activate or deactivate the respective special functions.
- Confirm = press rotary knob.



To define the following start-up values:

- Tube compensation (ATC) on/off
- Tube compensation parameters

- Press the key » System Setup«.
- Touch the screen key »Therapy«.
- Touch the screen key »Mode & Settings« and enter the access code 3032.
- Touch the screen key »ATC...«.
- Touch the corresponding screen key to activate or deactivate the respective special functions.
- Confirm = press rotary knob.
- Touch the corresponding screen key to set the parameters for automatic tube compensation.
- Adjust and confirm with the rotary knob.

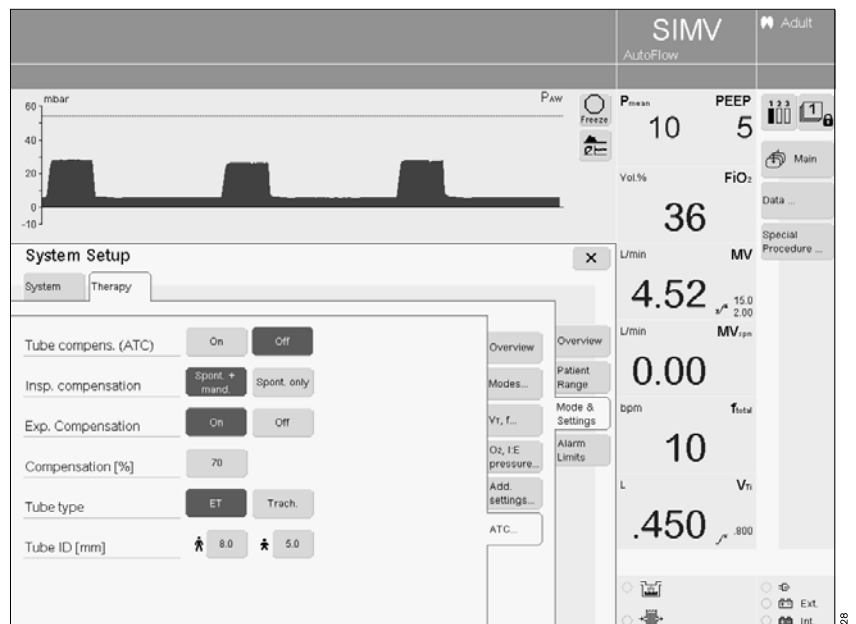

Set start-up alarm limits

- Press the key » System Setup«.
- Touch the screen key »Therapy«.
- Touch the screen key »Alarm Limits« and enter the access code 3032.

The current start-up alarm limits are displayed.

$\sqrt{\text{f}}$ = upper alarm limit

\surd = lower alarm limit

- Touch the corresponding screen key.
- Set and confirm with the rotary knob.



Parameter	Setting range	Start-up value set by manufacturer (Dräger Default)	Customised start-up value
$\sqrt{\text{f}}$ MV	0.5 to 41 L/min	$(V_T \cdot f) + 50 \%$
\surd MV	0.1 to 40 L/min	$(V_T \cdot f) - 20 \%$
$\sqrt{\text{f}}$ PAw	10 to 100 mbar	50 mbar
$\sqrt{\text{f}}$ VTi	0.03 to 4 L	VTi + 100 %
$\sqrt{\text{f}}$ fspn	5 to 120 bpm	50 bpm
$\sqrt{\text{f}}$ TApnoea	5 to 60 seconds	15 seconds
$\sqrt{\text{f}}$ etCO ₂ (optional)	0 to 100 mmHg (0.1 to 15 kPa)	60 mmHg
\surd etCO ₂ (optional)	0 to 99 mmHg (0 to 14.9 kPa)	30 mmHg

The set values can be entered in the column "Customised start-up value".

To restore the manufacturer's default settings:

- Touch the screen key »Dräger Default«.
- Confirm = press rotary knob.

Fault – Cause – Remedy

Fault – Cause – Remedy	144
------------------------------	-----

Fault – Cause – Remedy

EvitaXL shows alarm messages in hierarchical order in the alarm display field.

If two faults are detected at the same time, for example, the more critical of the two will be displayed.

The priority of the alarm messages is indicated by exclamation marks:

!!! = Alarm: Top priority message

!! = Caution: Medium priority message

! = Advisory: Low priority message

Messages are listed in alphabetical order in the following table. The table should help to identify and remedy the cause of an alarm more quickly. The various causes and remedies should be worked through in the order listed until the problem has been remedied.

Message		Cause	Remedy
Air supply down	!!!	Air supply pressure too low.	Make sure supply pressure is greater than 3 bar.
Air supply down	!	Air supply pressure too low. Air supply pressure not required when FiO ₂ = 100 Vol. %.	Make sure supply pressure is greater than 3 bar.
Air supply pressure high	!!	Air supply pressure too high.	Make sure supply pressure is less than 6 bar.
Air supply pressure high	!	Air supply pressure too high. Air supply not required for FiO ₂ = 100 Vol. %.	Make sure supply pressure is less than 6 bar.
Airway obstructed?	!!!	The ventilator applies only a very small volume with each mechanical stroke, e.g. because the tube is blocked.	Check condition of patient, check tube.
		Patient "fights" against the mechanical strokes in pressure-controlled ventilation, with the result that the set inspiratory pressure is reached with only a very small volume.	Check condition of patient, check ventilator settings.
Airway pressure high	!!!	The upper alarm limit for the airway pressure has been exceeded. The patient is "fighting" the ventilator or coughing.	Check patient condition. Check ventilation pattern. Correct alarm limits if necessary.
		Ventilation hose buckled.	Check hose system and tube.
Airway pressure low	!!!	Leaking cuff?	Inflate cuff and check for leaks.
		Leak or disconnection.	Check hose system for tight connections. Check that the expiration valve is properly engaged.
Ambient pressure sensor?	!!	Ambient pressure sensor faulty.	Note: The ventilator functions are not affected. Device can not be used in helicopters or aircraft. Call DrägerService.

Message		Cause	Remedy
Apnoea	!!!	Patient 's spontaneous breathing has stopped.	Check condition of patient, if necessary apply controlled ventilation.
		Stenosis	Check condition of patient. Check tube. Check hose system.
		Flow sensor not calibrated or faulty.	Calibrate flow sensor. Replace if necessary.
Apnoea alarm off	!	Apnoea monitoring has been switched off in application mode NIV.	Set the upper alarm limit for apnoea monitoring to the required value again.
		Apnoea monitoring is not active when nebulising without flow monitoring.	Use external monitoring or switch on flow monitoring or stop nebulising.
Apnoea ventilation	!!	Due to detected apnoea, the system has automatically switched over to mandatory ventilation.	Check ventilation procedure. Return to the original ventilation mode by pressing the »Alarm Reset« key and confirm. Check condition of patient. Check tube.
ASB > 4 s Not displayed in application mode »Mask/NIV«	!!!	The ASB phase was terminated 3 consecutive times after 4 seconds.	Test ventilation system for leaks.
ASB > 1.5 s	!	The ASB phase was terminated 3 consecutive times after 1.5 seconds.	Test ventilation system for leaks.
ASB > Tinsp	!	The ASB phase was terminated by a time limitation.	Test ventilation system for leaks.
Back-up ventilation	!!!	Tube blocked.	Check tube.
Breathing cycle not detected	!!!	The device does not deliver any gas.	Set P _{max} higher than PEEP setting. Extend alarm time T _{Apnoea} \sqrt{x} or increase IPPV frequency.
		Device faulty.	Disconnect patient from the device and continue ventilation without delay, using another independent ventilator. Call DrägerService.
Check frequency ILV Slave Message on slave device	!	The frequency (breathing rate) of the master and slave device differs by more than 12 %.	Adjust the frequency of the slave device to that of the master device.
Check settings	!!	Power interruption while setting ventilation pattern or the alarm limits.	Check pattern of ventilation and alarm limits. Acknowledge message by pressing »Alarm Reset« key and confirm.
Clean CO2 cuvette	!!!	Cuvette window for the CO2 measurement is dirty.	Use clean cuvette.
		Sensor window for the CO2 measurement is dirty.	Clean CO2 sensor.
CO2 measurement inop.	!!!	CO2 sensor faulty.	Replace faulty CO2 sensor.
		CO2 measurement incorrect.	The ventilator functions are not affected. Ensure adequate external monitoring without delay. Deactivate the internal CO2 monitoring. Call DrägerService.

Message		Cause	Remedy
CO2 monitoring off	!	CO2 monitoring is switched off.	Switch CO2 monitoring on again (page 118) or use adequate external monitoring if necessary.
CO2 sensor?	!!!	Probe of CO2 sensor for the CO2 measurement was removed during operation.	Reinsert probe.
		CO2 sensor for the CO2 measurement not positioned on cuvette.	Place CO2 sensor on cuvette.
		CO2 sensor for the CO2 measurement defective.	Replace defective CO2 sensor.
CO2 zero?	!!!	Zero point for the CO2 measurement is outside the permissible tolerance.	Perform zero calibration, page 111.
		Zero calibration for the CO2 measurement unsuccessful.	Perform zero calibration correctly.
Device failure	!!!	Device faulty.	Ventilation can be continued if the message disappears when the »Alarm Reset« key is pressed. If it does not: disconnect the patient from the device and continue ventilation immediately with another independent ventilator. Call DrägerService.
etCO2 high	!!!	Upper alarm limit for end-expiratory CO2 concentration in CO2 measurement has been exceeded.	Check condition of patient, check ventilation pattern, correct alarm limit if necessary. Perform CO2 zero if applicable.
etCO2 low	!!!	Lower alarm limit for end-expiratory CO2 concentration in CO2 measurement has been exceeded.	Check condition of patient, check ventilation pattern, correct alarm limit if necessary. Perform CO2 zero if applicable.
Evita Remote?	!	The remote control pad was not recognised by the device.	Remove Remote Pad. Acknowledge message by pressing »Alarm Reset« key and confirm. Note: The ventilator functions of the device are not affected. Call DrägerService.
Evita Remote inop.	!	Key pressed on "Remote Pad" during selftest.	Acknowledge message by pressing »Alarm Reset« key and confirm. Remove Remote Pad and reconnect. Ensure that no key is pressed on the Remote Pad during self-test.
		Remote control pad faulty.	Acknowledge message by pressing »Alarm Reset« key and confirm. Remove Remote Pad. The ventilator functions of the device are not affected. Call DrägerService.
Execute device check	!!	Device check not performed.	Perform equipment check, page 34. Acknowledge message by pressing »Alarm Reset« key and confirm.

Message		Cause	Remedy
Exp. hold interrupted	!	The »Exp. hold« key was activated for longer than 15 seconds.	Release »Exp. hold« key.
Exp. valve faulty	!!!	Expiration valve not properly connected to socket.	Push expiration valve firmly into socket until it clicks into place.
		Flow sensor not calibrated or defective.	Calibrate flow sensor, (page 106) replace if necessary.
		Expiration valve faulty.	Replace expiration valve.
Ext. battery – Voltage high	!	External battery has been connected with excessively high voltage when using DC.	Connect a 12 V or 24 V battery.
Ext. battery polarity reversed	!	External battery has been connected with wrong polarity when using DC.	Connect the external battery correctly, see page 173.
External Flow	!	EvitaXL monitors the externally supplied flow when external flow measurement is activated.	Deactivate calculation of external flow, see page 107.
Fan failure?	!!!	Temperature in machine is too high. Fan failure?	Check fan function, clean or replace cooling air filter. Check ambient air temperature. Disconnect patient from the device and continue ventilation immediately with another independent ventilator. Call DrägerService.
Fan malfunction	!	Temperature in machine is too high.	Check fan function, clean or replace cooling air filter. Check ambient air temperature. Ventilation with the device can be continued. Call DrägerService.
FiO2 high	!!!	O2 sensor not calibrated.	Calibrate O2 sensor, page 109.
		Faulty mixer function.	The ventilation functions are not affected. If ventilation shall be continued: use external O2 monitoring and switch off the built-in O2 monitoring. Call DrägerService.
FiO2 low	!!!	O2 sensors not calibrated.	Calibrate O2 sensor, page 109.
		Faulty mixer function.	The ventilation functions are not affected. If ventilation shall be continued: use external O2 monitoring and switch off the built-in O2 monitoring. Call DrägerService.
Flow measurement inop.	!!!	Water in flow sensor.	Dry flow sensor.
		Flow sensor or flow measurement faulty.	Calibrate flow sensor (page 106), replace if necessary.
		Flow measurement malfunction.	The ventilator functions are not affected. If ventilation shall be continued: use external flow monitoring and deactivate the integrated flow monitoring. Call DrägerService.
Flow monitoring off	!	Flow monitoring is switched off.	Switch flow monitoring on again page 118 or immediately ensure an adequate external monitor function.

Message		Cause	Remedy
Flow Sensor?	!!!	Flow sensor not fully inserted in rubber lip of expiration valve.	Insert flow sensor correctly.
Hose kinked	!!	The pressure at the inspiratory port is greater than 30 mbar, e.g. due to a kinked or blocked hose, or a blocked patient mask.	Check patient hoses, check patient mask.
High frequency	!!!	Patient is breathing at a high spontaneous frequency.	Check condition of patient. Check pattern of ventilation or spontaneous breathing frequency. Check hose system for water (auto triggering). Correct alarm limit if necessary.
ILV sync. inop. Message on both devices	!!!	Frequency on master device less than 4 breaths per minute.	Set a higher frequency.
		Fault in communication between the units.	The ventilator functions are not affected, but there is no communication between the two units. Replace ventilator to continue use of ILV. Call DrägerService.
Insp. hold interrupted	!	The »Insp. hold« key was operated for longer than 15 seconds.	Release »Insp. hold« key.
Int. battery discharged	!!!	The ventilator is being powered by DC integrated battery due to the absence of mains power and an external battery. The time for operation with power from the integrated battery has expired.	Connect ventilator immediately to mains power supply or to a fully charged external battery.
Int. battery in operation	!	The ventilator is being powered by DC integrated battery due to the absence of mains power and an external battery. The maximum remaining time from the integrated battery is 10 minutes.	Connect ventilator to the mains power supply or to a fully charged battery within 10 minutes.
Int. battery only 2 minutes left	!!	The ventilator is being powered by DC integrated battery due to the absence of mains power and an external battery. The maximum remaining time from the integrated battery is 2 minutes.	Connect ventilator to the mains power supply or to a fully charged battery within 2 minutes.
Key O2 ↑ suction overused?	!!	Key has been pressed frequently in a short period of time.	Acknowledge message by pressing »Alarm Reset« key and confirm. If this message appears repeatedly: Disconnect patient from the device and continue ventilation immediately with another independent ventilator. Call DrägerService.
Key overused?	!!	Due to frequent key use, the screen contents of the display are repeatedly redrawn.	Acknowledge message by pressing »Alarm Reset« key and confirm.
		Brief communication failure between display processor and main processor.	Acknowledge message by pressing »Alarm Reset« key and confirm. If this message appears repeatedly: Disconnect patient from the device and continue ventilation immediately with another independent ventilator. Call DrägerService

Message		Cause	Remedy
Leakage Not displayed in application mode »Mask/NIV«	!	The measured minute volume leak MV_{leak} is 20 % higher than the minute volume measured on the expiration side.	Check that the patient hose connection has no leaks. Check that the tube is correctly fitted.
Loss of data	!!!	Lithium battery discharged.	The ventilator functions are not affected. Ventilation can be continued. Check settings. Call DrägerService.
MEDIBUS COM. inop.	!	The MEDIBUS cable has been unplugged during operation when using EvitaLink.	Plug the connector in again and secure it against disconnection with the two screws.
		MEDIBUS cable defective.	Use a new MEDIBUS cable.
		Interface defective.	Ventilation can be continued. Call DrägerService.
Mixer inop.	!!!	Mixer malfunction. FiO ₂ can deviate considerably.	Immediately disconnect the patient from the device and continue ventilation without delay using another independent ventilator. Call DrägerService.
Multi functional board inop.	!!	The multi-functional board for operating the nurse call is faulty.	Acknowledge message by pressing »Alarm Reset« key and confirm. The ventilator functions are not affected. However, correct operation of the nurse call cannot be guaranteed. Disconnect nurse call from multi-function board. Call DrägerService.
Multi functional board inop.	!	The multi-functional board for operating the nurse call is faulty.	Acknowledge message by pressing »Alarm Reset« key and confirm. The ventilator functions are not affected. However, correct operation of the nurse call cannot be guaranteed. Disconnect nurse call from multi-function board. Call DrägerService.
MV high	!!!	The expired minute volume has exceeded the upper alarm limit.	Check condition of patient, check pattern of ventilation, adjust MV alarm limit if necessary.
		Flow sensor not calibrated or faulty.	Calibrate flow sensor, page 106 and replace if necessary.
		Water in flow sensor.	Drain water trap in hose system. Dry flow sensor.
		Machine malfunction.	Disconnect patient from the device and continue ventilation without delay using another independent ventilator. Call DrägerService.

Message		Cause	Remedy
MV low	!!!	The minute volume has fallen below the lower alarm limit.	Check condition of patient, check pattern of ventilation, adjust alarm limit if necessary.
		Stenosis	Check condition of patient. Check tube. Check hose system.
		Leak in breathing system	Establish leak-free breathing system.
		Flow sensor not calibrated or faulty.	Calibrate flow sensor (page 106), replace if necessary.
		Machine malfunction.	Disconnect patient from the device and continue ventilation without delay using another independent ventilator. Call DrägerService.
MV low alarm off	!	Monitoring of the lower alarm limit for minute volume has been deactivated in application mode NIV.	Set alarm limit MV \checkmark to the required value again.
Nebuliser on	!	The medicament nebuliser is switched on, page 91.	Switch off the medicament nebuliser if necessary, page 91.
Nebulisation interrupted	!!	Nebulisation is only possible in pressure-controlled ventilation or with AutoFlow.	Select the patient mode. Restart nebulisation. Acknowledge the alarm with »Alarm Reset« key and confirm.
		Flow sensor not ready for measurement.	Switch on flow monitoring or calibrate sensor or replace flow sensor or change mode of ventilation. Restart nebulisation. Acknowledge the alarm with »Alarm Reset« key and confirm.
No pulse signal	!!!	The SpO ₂ sensor has become displaced.	Check that the SpO ₂ sensor is correctly fitted.
O₂ calibration overused ?	!!	Key has been pressed frequently in a short period of time.	Acknowledge message by pressing »Alarm Reset« key and confirm. If this message appears repeatedly: Disconnect patient from the device and continue ventilation with another independent ventilator. Call DrägerService.
O₂ measurement inop.	!!!	O ₂ sensor provides invalid measured values.	Calibrate O ₂ sensor (page 115), replace if necessary.
		O ₂ measurement malfunction.	Ventilation can be continued: use external O ₂ monitoring and deactivate integrated O ₂ monitoring. Call DrägerService.
O₂ monitoring off	!	O ₂ monitoring switched off.	Switch internal O ₂ monitoring on again (page 118) or immediately ensure an adequate external monitor function.
O₂ supply down	!!!	O ₂ supply pressure too low.	Make sure supply pressure is greater than 3 bar.
O₂ supply down	!	O ₂ supply pressure too low. O ₂ supply is not required for FiO ₂ = 21 Vol.%.	Make sure supply pressure is greater than 3 bar.

Message		Cause	Remedy
O2 supply pressure high	!!	O2 supply pressure too high.	Make sure supply pressure is less than 6 bar.
O2 supply pressure high	!	O2 supply pressure too high. O2 supply is not required for FiO ₂ = 21 Vol.%. FiO ₂ = 21 Vol.%.	Make sure supply pressure is less than 6 bar.
O2 Therapy active	!	O2 therapy is activated.	Switch off O2 therapy. Exit Standby.
PEEP high	!!!	Expiratory system obstructed.	Check hose system and expiration valve. Check also for condensate.
		Expiratory resistance is increasing.	Check bacterial filter. Replace if necessary.
		Machine faulty.	Disconnect patient from the device and continue ventilation without delay using another independent ventilator. Call DrägerService.
PEEP valve inop.	!!!	Internal PEEP valve faulty.	Disconnect patient from the device and continue ventilation without delay using another independent ventilator. Call DrägerService.
PPS-Insp. > 4 s	!!!	The inspiration phase during PPS was terminated 3 consecutive times after 4 seconds.	Check the ventilation system for leaks.
PPS-Insp. > 1,5 s	!	The inspiration phase during PPS was terminated 3 consecutive times after 1.5 seconds.	Check the ventilation system for leaks.
Pressure limited	!	P _{max} pressure limit is active.	Check the condition of the patient. Check pattern of ventilation. Correct setting if necessary.
Pressure meas. inop.	!!!	Fluid in expiration valve.	Replace expiration valve (page 158) then clean and dry.
		Pressure measurement malfunction.	Disconnect patient from the device and continue ventilation immediately with another independent ventilator. Call DrägerService.
Procedure overused ?	!!	Total time of procedures has exceeded 15 minutes within the last hour.	Acknowledge message by pressing »Alarm Reset« key and confirm. If this message appears repeatedly: Disconnect patient from the device and continue ventilation immediately with another independent ventilator. Call DrägerService.
Pulse rate high	!!!	The pulse rate exceeds the upper alarm limit.	Check the condition of the patient. Check the ventilation pattern. If necessary, adjust the alarm limit.
Pulse rate high	!	The pulse rate exceeds the upper alarm limit.	Check the condition of the patient. Check the ventilation pattern. If necessary, adjust the alarm limit.
Pulse rate low	!!!	The pulse rate has fallen below the lower alarm limit.	Check the condition of the patient. Check the ventilation pattern. If necessary, adjust the alarm limit.

Message		Cause	Remedy
Pulse rate low	!	The pulse rate has fallen below the lower alarm limit.	Check the condition of the patient. Check the ventilation pattern. If necessary, adjust the alarm limit.
Remote Computer Control	!	This message is displayed to inform the user that Evita is being controlled via PC.	Remote control can be interrupted at any time by pressing the function key »Remote«.
Rotary knob xx failed	!!	Key xx can no longer be operated.	Disconnect patient from device and continue ventilation immediately with another independent ventilator. Call DrägerService.
Rotary knob xx overused?	!!	Key has been pressed frequently in a short period of time.	Acknowledge message by pressing »Alarm Reset« key and confirm. If this message appears repeatedly: Disconnect patient from the device and continue ventilation immediately with another independent ventilator. Call DrägerService.
SpO2 high	!!!	The SpO2 value exceeds the upper alarm limit.	Check the condition of the patient. Check the ventilation pattern. If necessary, adjust the alarm limit.
SpO2 high	!	The SpO2 value exceeds the upper alarm limit.	Check the condition of the patient. Check the ventilation pattern. If necessary, adjust the alarm limit.
SpO2 low	!!!	The SpO2 value is below the lower alarm limit.	Check the condition of the patient. Check the ventilation pattern. If necessary, adjust the alarm limit.
SpO2 low	!	The SpO2 value is below the lower alarm limit.	Check the condition of the patient. Check the ventilation pattern. If necessary, adjust the alarm limit.
SpO2 meas. inop.	!!!	SpO2 sensor defective.	Change sensor.
		SpO2 measurement defective.	In order to continue ventilating with the device: Use external SpO2 monitoring and switch off the built-in SpO2 monitoring. Call DrägerService
SpO2 monitoring off	!	SpO2 monitoring switched off.	Switch SpO2 monitoring on or ensure adequate external SpO2 monitoring.
SpO2 sensor?	!!!	The SpO2 sensor was disconnected while in operation.	Reconnect the sensor. Test.
		Sensor defective.	Use a new sensor.
Standby activated	!!!	EvitaXL has been switched to standby.	Acknowledge standby with »Alarm Reset« key and confirm.
Temperature high	!!!	Breathing gas temperature higher than 40 °C.	Switch off humidifier.
Temperature meas. inop.	!!!	Temperature sensor faulty.	Fit new temperature sensor, see page 27.
Temperature sensor?	!!!	Temperature sensor probe has been disconnected during operation.	Reconnect probe.
		Sensor cable broken.	Fit new temperature sensor.

Message		Cause	Remedy
Tidal volume high	!!!	The upper alarm limit of the applied inspiratory tidal volume V_{Ti} has been exceeded during three consecutive ventilation strokes.	Check condition of patient. Check pattern of ventilation. Correct alarm limit if necessary.
		Leak or disconnection.	Check hose system connections for leakages.
Tidal volume high	!	The upper alarm limit of the applied inspiratory tidal volume V_{Ti} has been exceeded.	Check condition of patient. Check pattern of ventilation. Correct alarm limit if necessary.
		Leak or disconnection.	Check hose system connections for leakages.
Vol. not const., pressure limited	!!	Due to pressure limit or time limit, the set tidal volume V_T has not been applied.	Prolong inspiratory time » T_{insp} «, increase inspiratory flow »Flow«, increase pressure limit » P_{max} «. Press the »Alarm Reset« key and confirm to suppress the visual and acoustic alarms until the cause of the alarm is remedied.
VTi high alarm off	!	The upper alarm limit for the inspiratory tidal volume V_{Ti} \sqrt{x} has been deactivated in application mode NIV.	Set alarm limit V_{Ti} \sqrt{x} to the required value.

Preparing

Preparing	156
Dismantling	156
Disinfecting and Cleaning	159
Care list for the intensive-care ventilator EvitaXL	162
Assembling	163
Before Reusing on Patient	163

Preparing

- **Note the hospital hygiene regulations!**

The ventilator must be cleaned and conditioned after every patient.

To avoid all risk of infection by hospital staff and other patients, the ventilator must be disinfected and cleaned whenever it has been used (protective clothing, eye protection, etc.).

Dismantling

- Switch off the ventilator and humidifier, and remove their power plugs.
- Drain the water traps and ventilation hoses.
- Drain the water container of the humidifier.

CO₂ sensor (optional)

- 1 Remove from the cuvette. Unplug the connector from the back of EvitaXL.
 - 2 Remove the cuvette of the CO₂ sensor from the Y-piece.
 - 3 Remove the catheter cone from the cuvette.
- Wipe-disinfect the CO₂ sensor, see page 160.
 - Condition the cuvette in a cleaning and disinfection machine, see page 161.

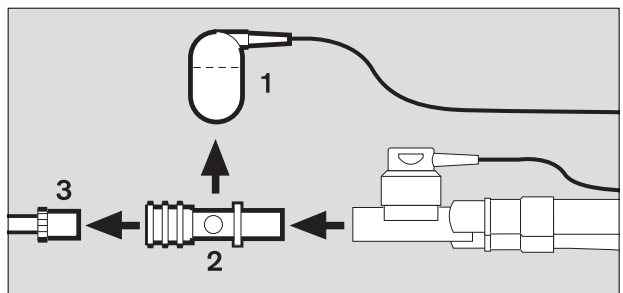

Temperature sensor

- 4 Remove from the Y-piece or from the mounting of hose set K. Do not pull the cable.
- Unplug the connector from the back of EvitaXL.
 - Wipe-disinfect the temperature sensor, see page 160.
- **The temperature sensor must not be conditioned in a cleaning and disinfection machine, nor placed in a disinfectant bath.**
Liquid may seep inside the sensor and impair its functioning!

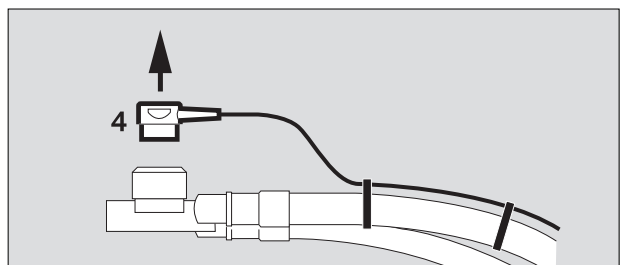

Medicament nebuliser (optional)

- 1 Remove the nebuliser hose from the nebuliser and from the port on the device.
- 2 Remove the medicament nebuliser from the adult hose system or

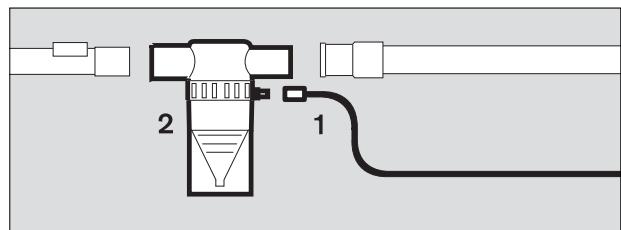

- 2 dismantle the medicament nebuliser from the paediatric hose system.
 - 3 Remove the catheter connector (ISO cone Ø15/ Ø11) from the inlet.
 - 4 Remove adapter (ISO cone Ø22/ Ø11) from the outlet.
 - 5 Remove corrugated hose from the adapter.
- Dismantle the medicament nebuliser in accordance with its specific Instructions for Use.
 - The individual parts of the medicament nebuliser and the adapter parts are conditioned in a cleaning and disinfection machine, see page 161.

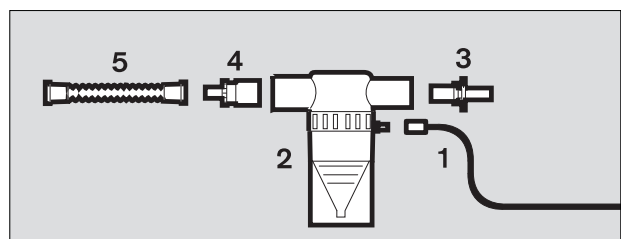

Ventilation hoses

- Remove from the adapters and ports.
- Remove the water traps from the ventilation hoses. Remove the collecting jars from the water traps.
- Ventilation hoses, water traps and their collecting jars and the Y-piece are conditioned in a cleaning and disinfection machine, see page 161.

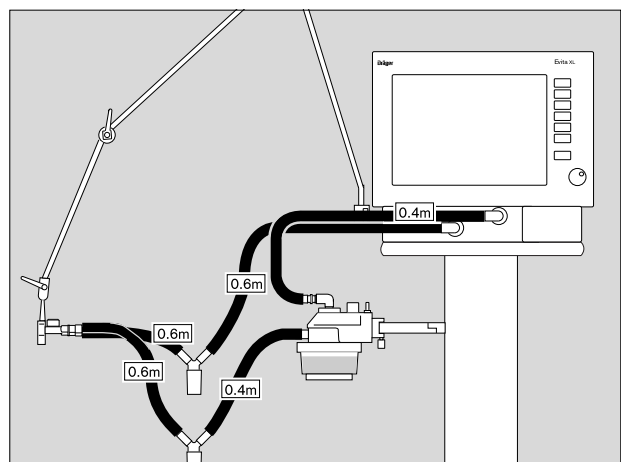

- Always hold the hoses by the connection sleeve and not by the spiral ribbing when removing and connecting the ventilation hoses, otherwise the spiral ribbing or the hose may be torn off the sleeve.

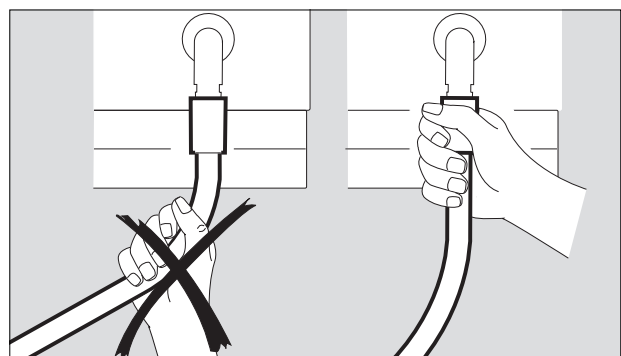

Flow sensor

- Tilt the control unit upwards, pressing the segments on the right and left down and at the same time tilting the control unit into the required position.

- 1 Push the flow sensor as far as possible to the left and
- 2 remove it.

- **The flow sensor cannot be disinfected/cleaned in a cleaning and disinfection machine.**
- **The Spirolog flow sensor must not be sterilised in hot steam. It is not resistant to high temperatures and may be destroyed.**

- Disinfect the flow sensor in 70 % ethanol solution for approx. 1 hour.

- Let the sensor dry in air for at least 30 minutes, otherwise residual alcohol may damage the sensor during calibration.

- Sterilise the SpiroLife flow sensor in hot steam at 134 °C.
- The flow sensor can be reused as long as automatic calibration is possible.

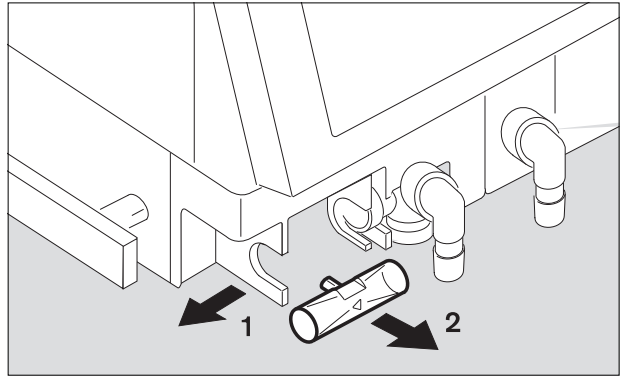

Expiration valve

- 3 Push the catch to the right
- 4 while at the same time pulling out the expiration valve.

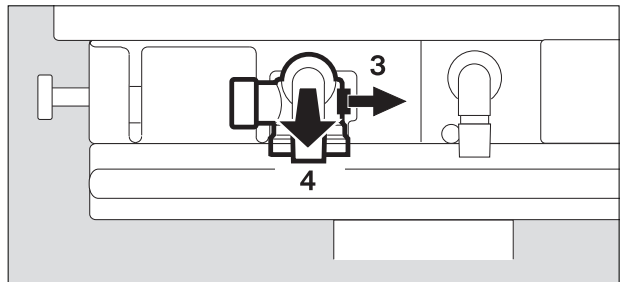

If the expiration valve has an optional water trap:

- Pull off the collecting jar.

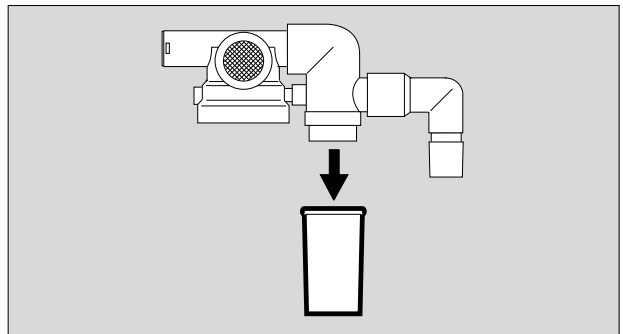

The expiration valve is only dismantled if severely soiled:

- Unscrew the stopper by hand and remove together with the diaphragm.
- Do not disassemble the expiration valve any further.
- The expiration valve is conditioned in a cleaning and disinfection machine, see page 161,

and

- prepare the expiration valve for hot steam sterilisation.
- Place the open expiration valve in the basket so that it cannot be damaged by other parts.

- Dispose of disposable expiration valves with normal domestic waste.

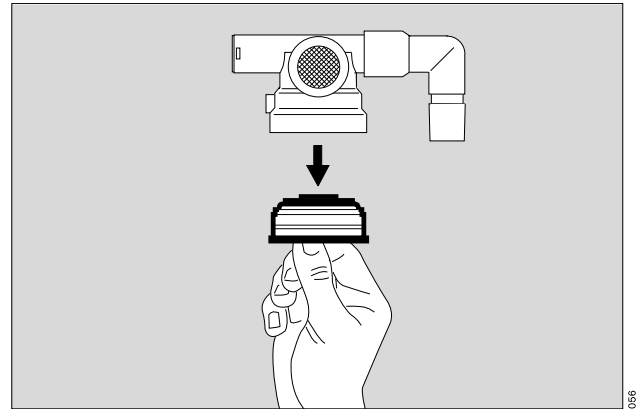

Breathing gas humidifier

- Dismantle in accordance with the specific Instructions for Use and prepare for disinfecting/sterilising.

Disinfecting and Cleaning

Use surface disinfectants. For surface compatibility, use disinfectants based on:

- aldehydes,
- quaternary ammonium compounds.

To avoid the possibility of damage to material, do not use any disinfectants based on:

- alkylamine-based compounds,
- phenol-based compounds,
- halogen-releasing compounds,
- strong organic acids,
- oxygen-releasing compounds.

For users in the Federal Republic of Germany, we recommend that only disinfectants on the current DGHM list are used (DGHM: German Society for Hygiene and Microbiology). The DGHM list (published by mhp-Verlag, Wiesbaden, Germany) also classifies each disinfectant by its active agents. For countries where the DGHM list is not available, we recommend the types of disinfectant given above.

Disinfectants often contain – besides their main active agents – additives that can also damage materials. See page 197 for a list of the materials used.

- If in doubt, contact the supplier/manufacturer of the disinfectant/cleaning agent.
- Note the manufacturer's directions for use.

To avoid all risk of infection by hospital staff and other patients, the ventilator must be disinfected and cleaned whenever it has been used (protective clothing, eye protection, etc.).

- Do not sterilise parts in ethylene oxide!
Ethylene oxide may diffuse into the parts and cause damage to health!

The screen is made of Plexiglas.

- Do not treat with alcohol or agents containing alcohol.
Danger of cracking.

Basic device without ventilation hoses, gas connection hoses

Wipe disinfect

- e.g. with Buraton 10 F or Terralin (Schülke & Mayr, Norderstedt).
Comply with the manufacturer's instructions.

Temperature sensor

- Wipe disinfect

CO₂ sensor and test filter (optional)

- Wipe off dirt with cotton buds, in particular on the windows of the CO₂-sensor.
- Disinfect by wiping, e.g. with 70 % ethanol.

CO₂ Cuvette (optional)

Wipe off dirt, particularly inside and outside the windows:

- with disposable tissue and cotton buds, under running water if necessary.

Then:

- Disinfect with moist heat (93 °C/10 minutes) in a cleaning and disinfecting machine. Only use cleaning agent.

Or:

- Disinfect in bath of disinfectant based on the listed active substances, e.g. Cidex, Johnson & Johnson, Norderstedt.

Or:

- Steam-sterilise at 134 °C.

As for ventilation hoses, water traps and associated jars, Y-piece, expiration valve (or, in the event of severe soiling, their individual parts), individual parts of the medicament nebuliser and adapter parts

- Disinfect with moist heat (93 °C/10 minutes) in cleaning and disinfecting machine. Only use cleaning agent.

If a cleaning and disinfection machine is not available:

- Immerse the parts in a disinfectant bath, e.g. with Sekusept made by Messrs. Henkel. Comply with the manufacturer's instructions.
- Then rinse with clean water, preferably from a soft water supply.
- Shake water out thoroughly, and leave the products to dry.

Expiration valve and its individual parts after disinfection

- Rinse thoroughly with clear water, preferably from a soft water supply. Shake water out thoroughly.
- After rinsing thoroughly, dry expiration valve.
- After drying, sterilise in hot steam at 134 °C, otherwise liquid may remain in the pressure measuring line and impair correct functioning.

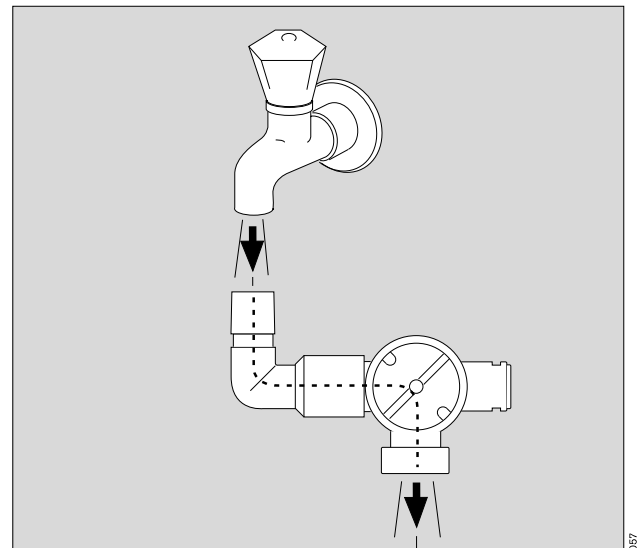

Ventilation hoses, water traps and associated water jars, Y-piece, temperature sensor

- These parts can be sterilised in hot steam at 134 °C.

Bacterial filter

- Must be conditioned in accordance with the separate Instructions for Use.

Humidifier

- Must be conditioned in accordance with the separate Instructions for Use.

Care list for the intensive-care ventilator EvitaXL

The following list applies to non-infectious patients.

If the ventilator is used with infectious patients, all parts in contact with breathing gas must be sterilised in addition to disinfection and cleaning.

The parts in contact with breathing gas and listed below can be sterilised in hot steam at 134 °C. Refer to the column "Sterilise".

The table is merely intended as a approximate guide. The instructions of the hospital's hygiene officer shall prevail!

What	How often	How			
		Disinfect and clean			Sterilise
		Cleaning and disinfection machine, 93 °C, 10 minutes	Wipe	Immerse	Hot steam 134 °C, 10 minutes
EvitaXL basic unit	Per patient	no	Outside	no	no
Trolley Hinged arm Compressed gas hose	Per patient	no	Outside	no	no
Ventilation hoses Y piece Water traps Collecting jars	Per patient/ weekly	yes	no	Possible	yes
Expiration valve	Per patient/ weekly*	yes	no	Possible	yes
Spirolog flow sensor	daily	no**	Outside	Possible**	no
SpiroLife flow sensor	daily	no**	Outside	Possible**	yes
Temperature sensor	daily	no	yes	no	yes
CO ₂ sensor (optional)	daily	no	yes***	no	no
Cuvette of the CO ₂ sensor (optional)	daily	yes	no	yes	yes
Test filter for CO ₂ sensor (optional)	daily	no	yes***	no	no
Humidifier	Per patient/weekly	In accordance with separate Instructions for Use			
Medicament nebuliser (optional)	Per patient/weekly	In accordance with separate Instructions for Use			
Bacterial filter		In accordance with separate Instructions for Use			

* Nebulisation may lead to formation of more extensive deposits necessitating more frequent replacement.

** Special treatment, immerse in a disinfectant bath with 70 % ethanol, see page 158.

*** Wipe-disinfect, e.g. with 70 % ethanol, see page 160.

Assembling

Mounting the expiration valve

- The parts must be entirely dry to prevent malfunctioning.
- Hold stopper by the flange and place diaphragm on the collar of the stopper. Be careful to fit the diaphragm properly.

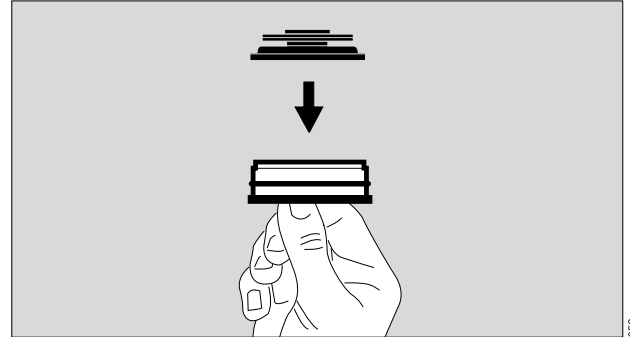

- Insert stopper with diaphragm on top into the housing from below and screw in tightly.

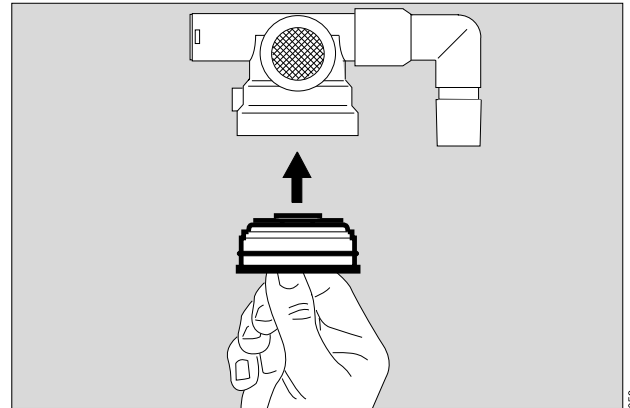

If the expiration valve has an optional water trap:

- Fit the collecting jar.

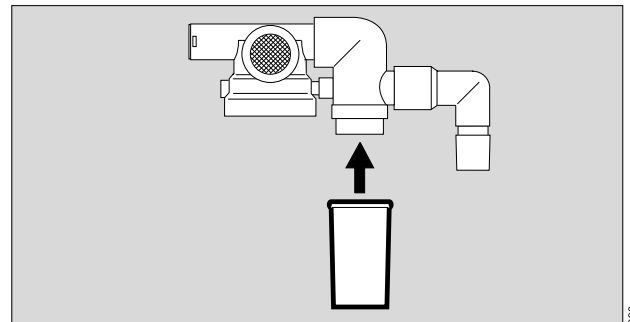

Medicament nebuliser

- Assemble in accordance with separate Instructions for Use, see page 92.

Breathing gas humidifier

- Assemble in accordance with separate Instructions for Use. Installation, see page 26 and page 28.

Before Reusing on Patient

- Assemble machine as described under "Preparing for use" on page 22.
- Carry out checks to ensure readiness for operation, see "Device Check" on page 34.

Maintenance/Disposal

Maintenance/Disposal	166
Replace cooling air filter	167
Removing and reinserting ambient air filter	167
Clean covering grid for heating patient part	168
Disposal	168

Maintenance/Disposal

Clean and disinfect equipment and/or components before any maintenance procedures – and before returning for repair!

O2 sensor	Replace sensor capsule in event of display message: O2 measurement inop and if calibration is no longer possible. Disposal, see page 168.
Ambient air filter and Cooling air filter	Clean or replace after 4 weeks, see page 167. Replace after 1 year. Dispose of with normal domestic waste.
Filters in the compressed gas inlets	To be replaced by trained service personnel every 2 years.
Covering grid for heating patient part	Clean after 4 weeks. Dirt blocks the air inlet and reduces the heating output.
Lithium battery for data protection	To be replaced by trained service personnel every 2 years. Disposal, see page 168.
Integrated battery of DC power supply	Must be serviced in conjunction with half-yearly inspections. To be replaced by trained service personnel every two years at the latest. Check capacity every six months! Replace battery if necessary.
External battery (optional)	Must be serviced in conjunction with half-yearly inspections. Check capacity every six months! Replace battery if necessary.
Clock module	To be replaced by trained service personnel after 6 years.
Pressure reducer	To be replaced every 6 years by DrägerService.
Equipment inspection and service	Every 6 months by trained service personnel.
Safety checks (only applies to the Federal Republic of Germany)	Every 6 months in accordance with Art. 6 MPBetreibV (see "Safety checks" sheet)

Replace cooling air filter

- Clean if soiled or after 4 weeks at the latest.
 Replace after 1 year at the latest.
- 1 Remove cooling air filter from its slot on the back of EvitaXL.
- Fit a new cooling air filter or clean the installed filter in warm soapy water and dry thoroughly.
- Insert the cooling air filter in the mount without creasing.
- The old cooling air filter can be disposed with domestic waste.

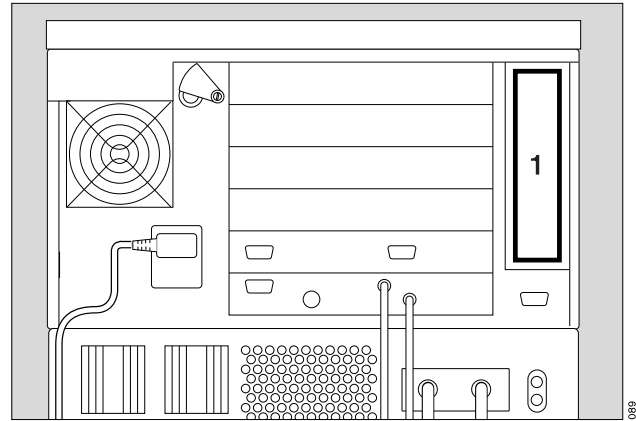

DC power supply MB:

- On the back of EvitaXL, undo the two knurled screws securing the grating over the power supply fan and remove the grating.
- Remove cooling air filter from its slot.
- Fit a new cooling air filter or clean the installed filter in warm soapy water and dry thoroughly.
- Insert the cooling air filter in the mount without creasing.
- Refit the grating over the cooling air filter and tighten the knurled screws by hand.
- The old cooling air filter can be disposed with domestic waste.

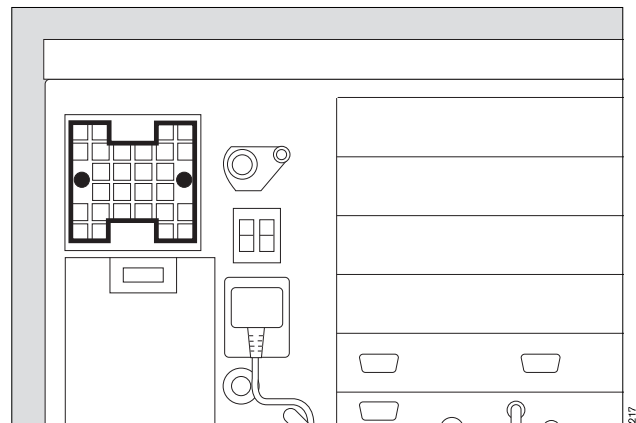

Removing and reinserting ambient air filter

- Clean after 4 weeks.
 Replace after 1 year at the latest.
- 2 If necessary, swivel port to the left.
- 3 Use coin to loosen screw, and remove protective cover.
- 4 Remove the ambient air filter from the protective cover.
- Slide the cleaned or new ambient air filter under the tabs.
- Replace protective cover, and tighten screw with a coin.
- Dispose of used ambient air filter with domestic waste.

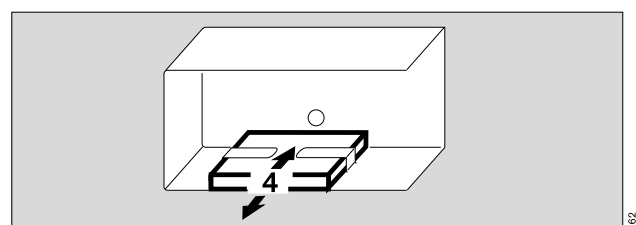
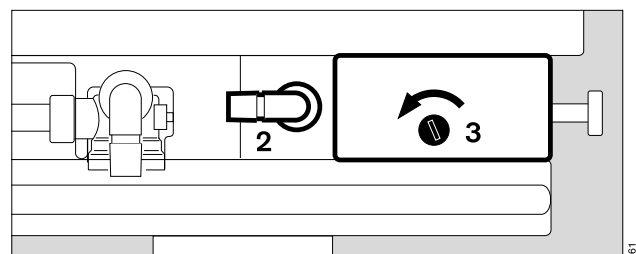

Clean covering grid for heating patient part

- Clean if soiled or after 4 weeks.
- Remove dirt on the covering grid using a disposable tissue.
Do not let any moisture get into EvitaXL!

Disposal

Correct disposal of batteries and O₂ sensors

Batteries and O₂ sensors:

- do not throw in a fire; risk of explosion!
- do not open using force; risk of corrosion!
- do not re-charge batteries.

The EvitaXL battery contains pollutant substances.

In the Federal Republic of Germany:

The user is obliged by the Ordinance governing correct disposal of batteries to return batteries which contain pollutant substances either to the manufacturer/sales outlet or to a collection centre operated by public waste disposal corporations.

The battery installed in EvitaXL must therefore be removed by DrägerService before the apparatus can be disposed of.

The applicable national regulations must be observed in all other countries.

O₂ sensors must be disposed of as special waste:

- Disposal must conform to local waste disposal regulations.
Information may be obtained from the local environmental and public health authorities and from approved waste disposal companies.

Correct disposal of EvitaXL

- at the end of its useful life
- After consulting the relevant waste disposal company, hand over EvitaXL for appropriate disposal.
- Note the applicable statutory regulations.

Mains power/DC power operation

Mains power/DC power operation	170
Components and definitions	170
Use of the power supplies	171
Operating periods	171
Charging the batteries	171
Charging times	172
Charge indication and battery charge state	172
Battery maintenance	172
Connecting an external battery	173
Installing external batteries in trolley (EvitaMobil)	173
Power supply displays	174
Operation with mains power	175
Operation with integrated battery	175
Operation with external battery (optional)	176

Mains power/DC power operation*

EvitaXL contains a DC power supply with integrated battery to ensure that operation of the ventilator can continue for at least 10 minutes following a power failure (provided that the battery is fully charged).

The ventilator can be powered from an external battery via this DC power supply.

Components and definitions

DC power supply FB and DC power supply MB

The DC power supply in EvitaXL is available in two versions, both of which operate in a similar manner:

- DC power supply FB (Fixed Batteries): in this version, the batteries are located inside the power supply and are only accessible after removing the power supply.
- DC power supply MB (Movable Batteries): the batteries for this version are located in a drawer. A filter is installed in front of the power supply fan.

Whenever reference is made in these Instructions for Use to the "DC power supply", the information applies equally to both versions. If the information applies to only one version, the version concerned is specified by reference to either the "DC power supply FB" or "DC power supply MB".

Integrated battery

The two 12 V lead-gel batteries integrated into the DC power supply are always supplied with the DC power supply.

The integrated battery in the DC power supply is only fully charged after charging for 24 hours.

- The integrated battery in EvitaXL must be charged for at least 24 hours, see "Charging the batteries", page 171.

The integrated battery is intended exclusively for emergency use and not for normal operation!

It is therefore essential to operate the ventilator with external battery power or mains power again as soon as possible after switching over to operation with integrated battery.

External batteries (optional)

Additional rechargeable 12 V or 24 V lead-gel batteries which are connected to EvitaXL via the DC socket. The external batteries are not supplied with the DC power supply.

It is advisable to use 24 V lead-gel batteries (or two 12 V lead-gel batteries connected in series) with a minimum capacity of 15 Ah. The efficiency of the DC power supply and the associated duty period is significantly higher when using these batteries than when using 12 V batteries with comparable capacity.

The external battery may also take the form of two 12 V lead-gel batteries accommodated in the base of the trolley. Refer to the Order List for details for purchasing these batteries and the required connecting lead.

Commercially available rechargeable lead-gel batteries can also be used. For requirements to be met by the external batteries, see "Technical data", page 200.

Only use rechargeable batteries!

Disposable batteries may explode during operation with mains power on account of the charging function of the DC power supply!

DC socket

Socket on the back of the DC power supply for connecting an external battery.

This socket is identified as follows:

DC power supply FB: 12 V; 24 V; VDC

DC power supply MB: 12 V/24 V; F200; F30A 80V.

Only use rechargeable batteries!

Disposable batteries may explode during operation with mains power on account of the charging function of the DC power supply!

Only external batteries (see page 170) may be connected to the DC socket and only using the connecting leads specified in the Order List.

Mains-powered equipment must not be connected to the DC socket!

Mains power supply (mains power)

AC power supply (= mains power supply) for the ventilator via the mains connecting cable.

For voltage ranges/characteristics of the mains power, see "Operating data", page 196.

* An Evita 4 oder Evita 2 dura unit which has been upgraded with the EvitaXL option can also be operated without the DC option.

Use of the power supplies

Operation is possible with either of the following configurations:

- Integrated battery only, with and without mains power supply,
- integrated battery and external battery, with and without mains power supply.

EvitaXL draws its electric power from one of the following sources, in the order of priority listed:

1. Mains power supply
2. External battery
3. Integrated battery

The changeover between these supplies is effected according to the following rules, without interrupting operation:

- If sufficient mains power is available, this source is always used.
- If sufficient mains power is not available and a sufficient voltage is present at the DC socket, EvitaXL is powered by the external battery.
The changeover to external battery power is effected without an alarm message.
- If sufficient mains power is not available and there is no DC power available at the DC socket (e.g. external battery discharged or not connected), EvitaXL is powered by the integrated battery.

In order to make use of as much power as possible, the ventilator switches back from the integrated battery to the external battery if it has been recharged. This function is only intended for use in emergencies and may lead to total exhaustion of the battery.

Without delay:

- The switched-on ventilator must be operated with mains power or a fully charged external battery again.

The integrated battery is not re-charged when operating with external battery power. The trickle charge merely prevents the battery from discharging completely!

Operating periods

The periods of operation with integrated or external battery power depend on the charge and type of batteries connected, see "Technical Data" on page 200.

Charging the batteries

When the ventilator is switched on and operated with mains power, the integrated batteries will be re-charged first and then the external batteries.

The ventilator may only remain connected to the mains supply in well ventilated rooms.

Oxyhydrogen gas is generated when charging batteries and may explode when a sufficient concentration has accumulated.

Ensure that EvitaXL is switched on!

Neither the integrated battery nor the external battery will be charged if EvitaXL is connected to mains power but not switched on!

Integrated battery

The integrated battery is only recharged when

- the ventilator is being powered by mains power **and**
 - EvitaXL is switched on, see "Switching on", page 45.
- It is sufficient when the ventilator is in Standby mode.

The integrated battery is only fully charged after 24 hours.

EvitaXL must therefore be switched on and remain connected to the mains power supply in Standby mode for at least 24 hours so that the integrated battery can be charged.

EvitaXL switches over to trickle charge when the end of charge is reached.

External battery

The external battery is only charged when

- the ventilator is being powered by mains power **and**
- EvitaXL is switched on, see "Switching on", page 45. **and**
- the integrated battery has been fully charged.

It is sufficient when the ventilator is in Standby mode.

The voltage of the on-line external battery (12 V or 24 V) is detected automatically by the DC power supply.

Charging times

The specified charging times apply when batteries are recharged immediately after a full discharge.

The charging time may be significantly longer if the batteries have discharged several times in succession without being fully recharged on mains power in the meantime.

The batteries must be fully operational.

Charge indication and battery charge state

Charging of the integrated and external batteries is interrupted when the charging current drops to a very low value upon reaching the end of charge. The battery is considered to be fully charged and this is indicated by a green battery symbol.

The battery capacity actually available at the end of the charging process depends, among other things, on the condition of the battery and on the ambient temperature. The battery capacity and condition of the battery cannot be determined by the DC power supply.

The green battery symbol indicates that the battery is fully charged. Even though the green symbol lights up, the capacity of old or defective batteries may be so small as to permit operation of EvitaXL for no more than a few minutes.

**Sufficient battery capacity is always required.
See "Battery maintenance"!**

Battery maintenance

To ensure maximum battery life:

- The battery should always be fully charged and where possible never left uncharged.

If the DC power supply is not used:

- Connect EvitaXL to mains power after not more than one month and switch it on for at least two hours in order to recharge the integrated battery.
- Then fully recharge any external batteries which may be connected.

If the battery is left uncharged for more than one month:

- The integrated and external batteries should be disconnected from EvitaXL by experts in order to reduce spontaneous discharge by the batteries.

Before reconnecting the integrated and external batteries, check that their capacity is still adequate. They may have become exhausted or damaged as a result of prolonged storage.

Batteries are wear parts. They must be replaced in accordance with the extent to which they are used.

- **Exhaustive discharges should be avoided, as they lead to premature wear!**

Batteries are wear parts. Their capacity must be checked regularly and the batteries replaced if necessary.

Connecting an external battery

Note requirements to be met by the external battery, see page 170.

- Connect the external battery using the battery cable in the battery cable kit (84 11 822).
- **Ensure that the battery is connected with correct polarity: black to –, red to +.**
- Plug the connector into the DC socket on the rear of unit.

Mains-powered equipment must not be connected to the DC socket!

The voltage of the external battery (12 V or 24 V) is detected automatically by EvitaXL.

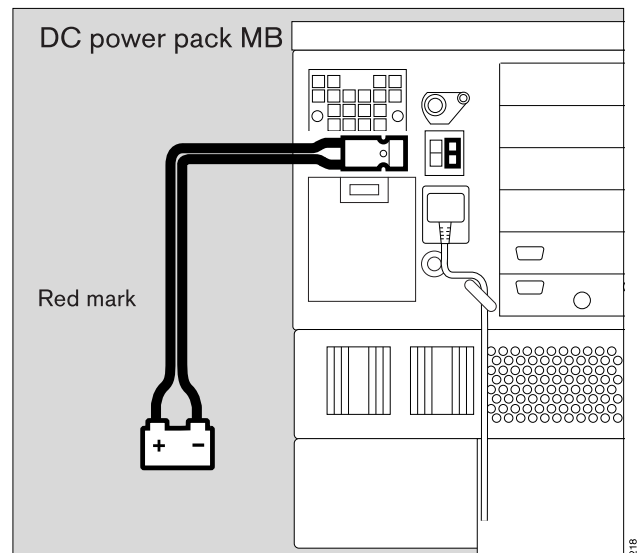
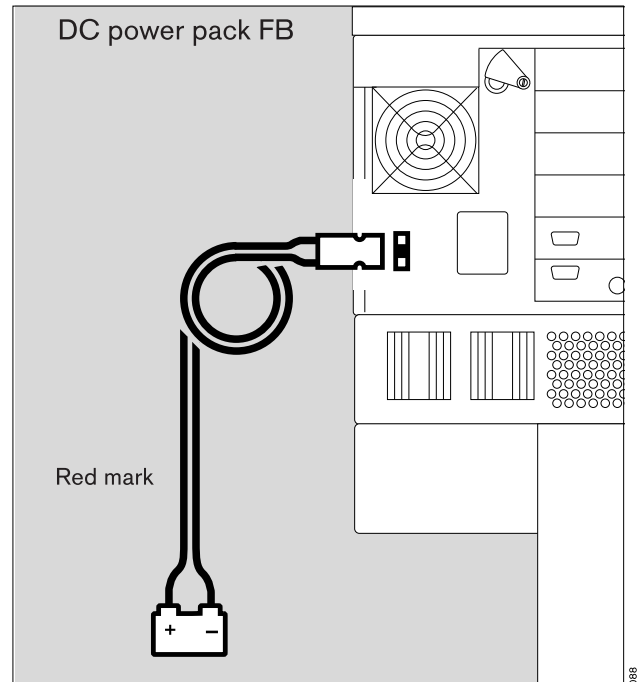

Installing external batteries in trolley (EvitaMobil)



Two batteries (18 43 303) and a battery cable from the battery cable kit (84 11 822) are required for this purpose.

- Note the installation instructions enclosed with the battery cable kit!

Power supply displays

The type of power supply is indicated by EvitaXL in the equipment status field at the bottom right of the screen via symbols and coloured LEDs.

Display (example):

-  : Mains power
-  Ext. : External battery
-  Int. : Integrated battery

A yellow LED lights up next to the relevant symbol to indicate the source from which EvitaXL is being powered.

Green LEDs next to the battery symbols indicate that the battery/batteries is/are fully charged.

Note the important information in the section "Charge indication and battery charge state" on page 172.

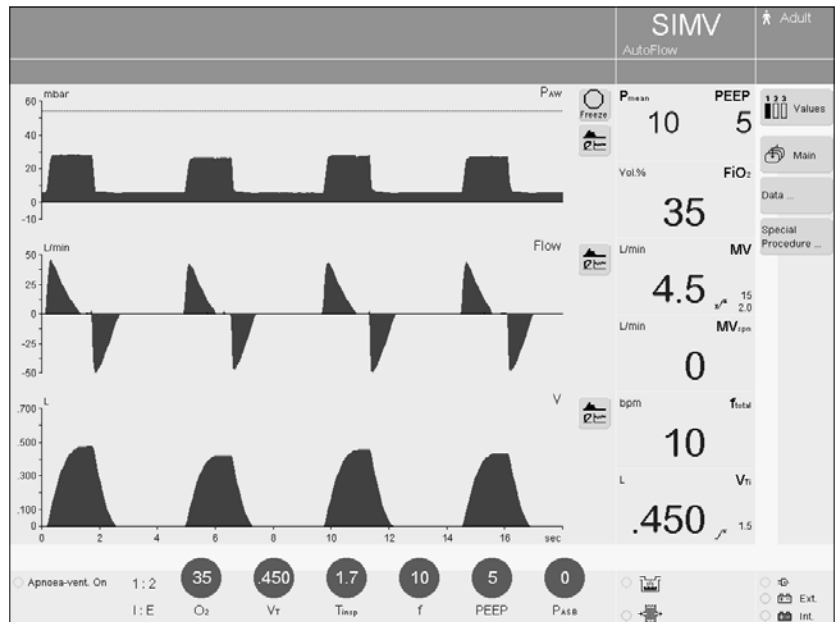

Operation with mains power

The ventilator switches to operation with mains power when connected to the mains power supply. The integrated battery is recharged during mains power operation. The external battery is recharged once the integrated battery is fully charged.

The LED next to the plug symbol  lights up yellow.

If the mains power supply fails, the ventilator automatically switches over to the external battery.

If an external battery is not available in the event of a power failure, the ventilator switches over to the integrated battery and continues operation for at least 10 minutes (provided that the integrated battery was fully charged).

- The mains power supply must be restored without delay.

To ensure that the battery is always fully charged:

- Connect the ventilator to the mains power supply and switch it on.

The ventilator may only remain connected to the mains supply in well ventilated rooms.

Oxyhydrogen gas is generated when charging batteries and may explode when a sufficient concentration has accumulated.

- Leave the ventilator in standby mode or start ventilation.

Operation with integrated battery

The ventilator immediately switches over to operation with the integrated battery if the mains power supply fails without an external battery being connected or if the external battery is exhausted.

The integrated battery is merely intended for emergency use and not for normal operation.

The LED next to the symbol for the integrated battery lights up yellow.

The green LED next to the symbol for the integrated battery goes out, as it is no longer fully charged.

When EvitaXL switches over to the integrated battery, the following advisory message is displayed:

Int. battery in operation !

The time available for operation with the integrated battery depends on its charge state. If the battery is fully charged, operation can continue for at least 10 minutes.

A caution message is displayed after 8 minutes of operation:

Int. battery only 2 minutes left !!

- The ventilator must be reconnected to the mains power supply within 2 minutes
- or
- it must be connected to a fully charged external battery!

After an operating time of 10 minutes has elapsed, the following alarm message is displayed:

Int. battery discharged !!!

- The power supply must be restored immediately, either from the mains supply or from a fully charged external battery, otherwise ventilation will be interrupted.

After being powered by the integrated battery:

- Recharge the integrated and external batteries as soon as possible, see "Charging the batteries", page 171.

Operation with external battery (optional)

Connecting an external battery

If the mains power supply fails, EvitaXL immediately switches over to the on-line external battery.

The LED next to the symbol for external battery lights up yellow.

The green LED next to the symbol for external battery goes out, as it is no longer fully charged.

The changeover to external battery power is effected without an alarm message.

The time available for operation with external battery depends on the battery charge state and the type of battery connected.

If the external battery is exhausted, EvitaXL automatically switches over to the integrated battery and generates an alarm.

When the mains power is restored, EvitaXL automatically switches back to operation with mains power.

The integrated battery is not recharged while the ventilator is being powered by an external battery!

For this reason:

- Recharge the integrated and external batteries as soon as possible, see "Charging the batteries", page 171.

Mains-powered equipment must not be connected to the DC socket!

Evita 4 Link (optional)

Evita 4 Link (optional)	178
Preparation	179

Evita 4 Link (optional)

In addition to the standard RS 232 interface COM 1, EvitaXL also has two serial RS 232 interfaces, COM 2 and COM 3, two CAN interfaces and an analogue interface with two channels.

On both serial interfaces

COM 2 and COM 3, the following can be output (optional):

- The LUST protocol*,
- the MEDIBUS protocol,
- a printer protocol.

The LUST protocol and printer protocol can only be output on one serial interface, while the MEDIBUS protocol can be output simultaneously on both serial interfaces.

Other equipment, e.g. printers, may only be connected to the COM interfaces if EvitaXL is connected to the mains power supply via a mains power cable or if it has been earthed via the earth connection on the back of EvitaXL.

Electric power may pose a hazard in all other cases.

For output of measured values, status messages and alarm messages to on-line equipment for monitoring, documentation or processing.

The on-line equipment may be a Dräger device or a device made by any other manufacturer.

All data transmitted in this way are intended for information only and must not be used as the sole basis for deciding on a particular therapy.

The RS 232 interfaces meet the requirements of the standards "EIA Standard RS 232 C" and "CCITT V.24".

* For a detailed description of the LUST protocol, see "Technical data, LUST protocol" on page 201.

Preparation

The interface board may only be installed by specialists.

Connect the RS 232 interface

using

MEDIBUS cable 83 06 488 for PC

or

printer cable 83 06 489 – for printer only

or

Monitor cable 57 22 410 – for monitor

- 1 Plug the connector into the socket »COM 2« or »COM 3« on the back of EvitaXL.
- Plug the other connector into the on-line equipment.
- Secure the connector = tighten the knurled screws.
- Prepare, connect and switch on the on-line device in accordance with the separate Instructions for Use.

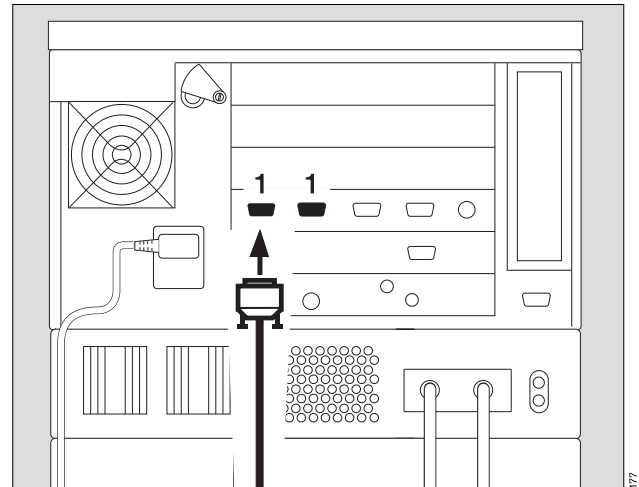

Connect analogue interface

with Evita analogue cable 84 11 759.

- 2 Plug the connector into the back of EvitaXL – »Analogue« socket.
- Prepare, connect and switch on the on-line device in accordance with the separate Instructions for Use.

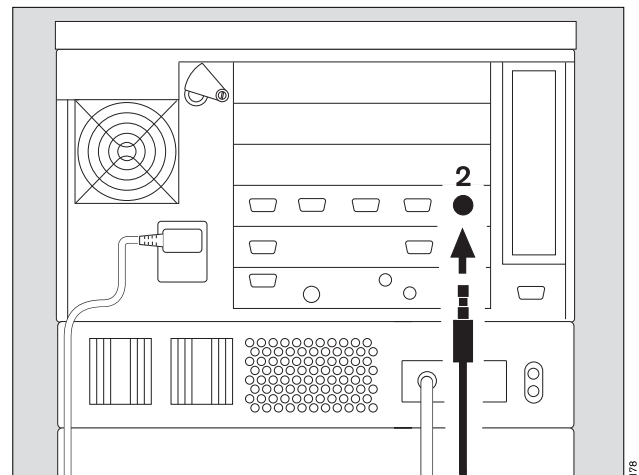

The connected devices must use the same protocol and the same data transfer format.

EvitaXL can use the following interface protocols:

- MEDIBUS (Dräger communication protocol for medical equipment, high-speed data, e.g. curves)
- LUST (List-controlled universal interface driver program, only for slow data, e.g. measured values)
- Printers

Select MEDIBUS protocol

For use of a PC with EvitaView software or for connecting a MEDIBUS-compatible monitor.

Refer to the Instructions for Use for "MEDIBUS for EvitaXL" and "Dräger RS 232 MEDIBUS protocol definition" 90 28 258 for a detailed description of the interface protocol.

- Press the key » **System Setup**«.
- In the menu »**System Setup**« touch the screen key »**Interface**«.

To select COM 1, COM 2 or COM 3 in the protocol field:

- Touch the screen key.
- Select the **Medibus** protocol = turn rotary knob, confirm = press rotary knob.
- Set the associated parameters **Baud rate**, **Parity**, **Stopbit**, **Interval** in the same way.

Select LUST protocol

For use of a monitor without real-time curves.

For a detailed description of the interface protocol, see "Technical data, LUST protocol" on page 201.

The LUST protocol cannot be configured simultaneously for COM 2 and COM 3.

To select COM 2 or COM 3 in the protocol field:

- Touch the screen key.
- Select the **LUST** protocol = turn rotary knob, confirm = press rotary knob.
- Set the associated parameters **Baud rate**, **Parity**, **Stopbit**, **Interval** in the same way.

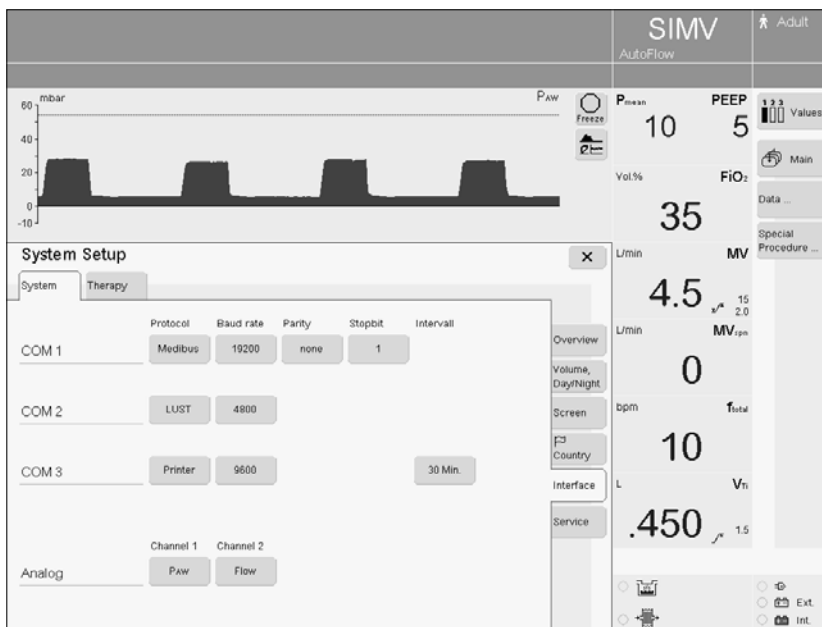

Select printer protocol

- See "Set interface" on page 136.

In addition to automatically triggered printouts at predetermined intervals, printing can also be started manually via the on-screen function key »Print«, see "Configuration", "Define function keys", page 130.

Analogue interface

The analogue interface on EvitaXL has two channels to which measured value signals can be assigned as desired.

Characteristics and PIN assignment

See "Technical data", page 198.

External voltages must not be applied here!

Assign channels:

- See "Set interface" on page 136.

Measured value signal	Designation	Range/voltage level
PAW	Airway pressure	-10 to 100 mbar 0 to 4.095 V
Flow	Expiratory and inspiratory flow	-196 to 196 L/min 0 to 4.095 V
V	Expiratory and inspiratory volume	0 to 2 L 0 to 4.095 V
MV	Minute volume	0 to 41 L/min 0 to 4.095 V
f	Ventilation frequency	0 to 150 bpm 0 to 4.095 V
FiO2	Inspiratory O2 concentration	0 to 100 Vol.% 0 to 4.095 V
R	Resistance	0 to 100 mbar/L/s 0 to 4.095 V
C	Compliance	0 to 250 mL/mbar 0 to 4.095 V
CO2	Expiratory O2 concentration	0 to 15 kPa 0 to 4.095 V
etCO2	End-expiratory CO2 concentration	0 to 15 kPa 0 to 4.095 V
NO	Inspiratory flow for NOdomo	0 to 125 L/min 0 to 4.095 V

What's what

What's what	184
Control unit	184
Front connections	185
Back panel	186

What's what

Control unit

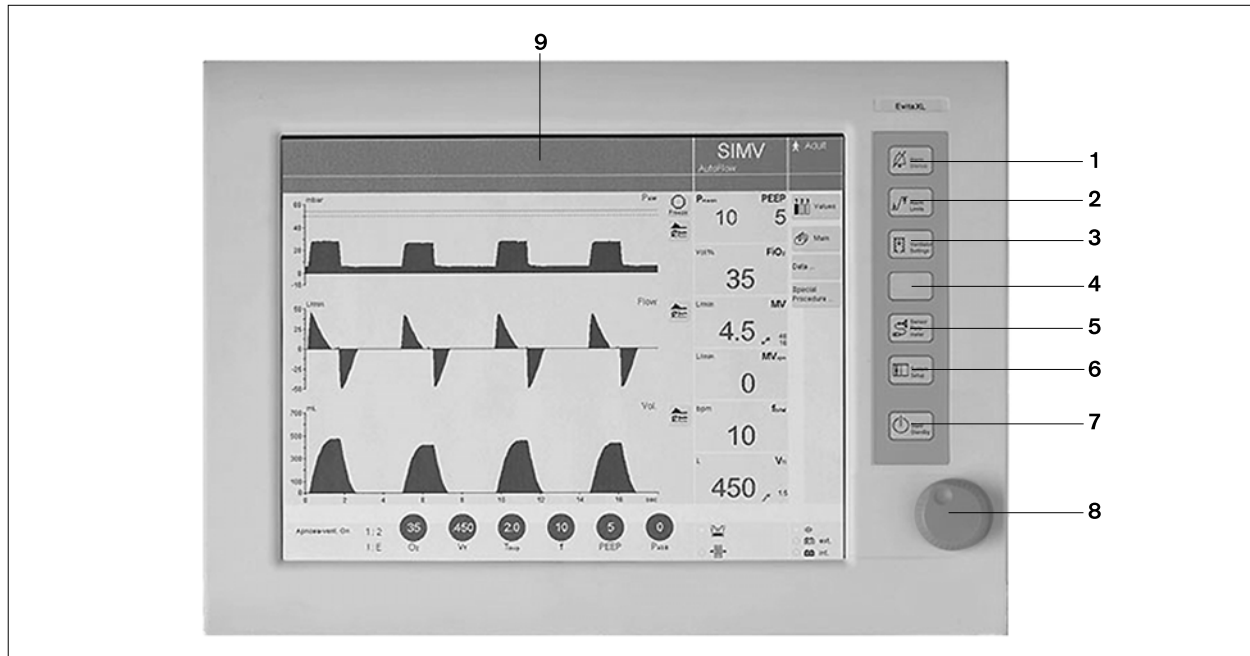

EvitaXL_06_01av.tif

- 1 » **Alarm Silence**« key for suppressing the alarm tone for 2 minutes
- 2 » **Alarm Limits**« key for setting the alarm limits
- 3 » **Ventilator Settings**« key for setting the ventilation mode and ventilation parameters
- 4 Unassigned key for future functions
- 5 » **Sensor Parameter**« key for calibrating the sensors and for activating/deactivating monitoring
- 6 » **System Setup**« key for configuring the equipment functions
- 7 » **Start/Standby**« key for changing back and forth between operation and standby mode
- 8 Central rotary knob for selecting and confirming settings
- 9 Touch-sensitive screen for displaying screen setups specific to the application

Front connections

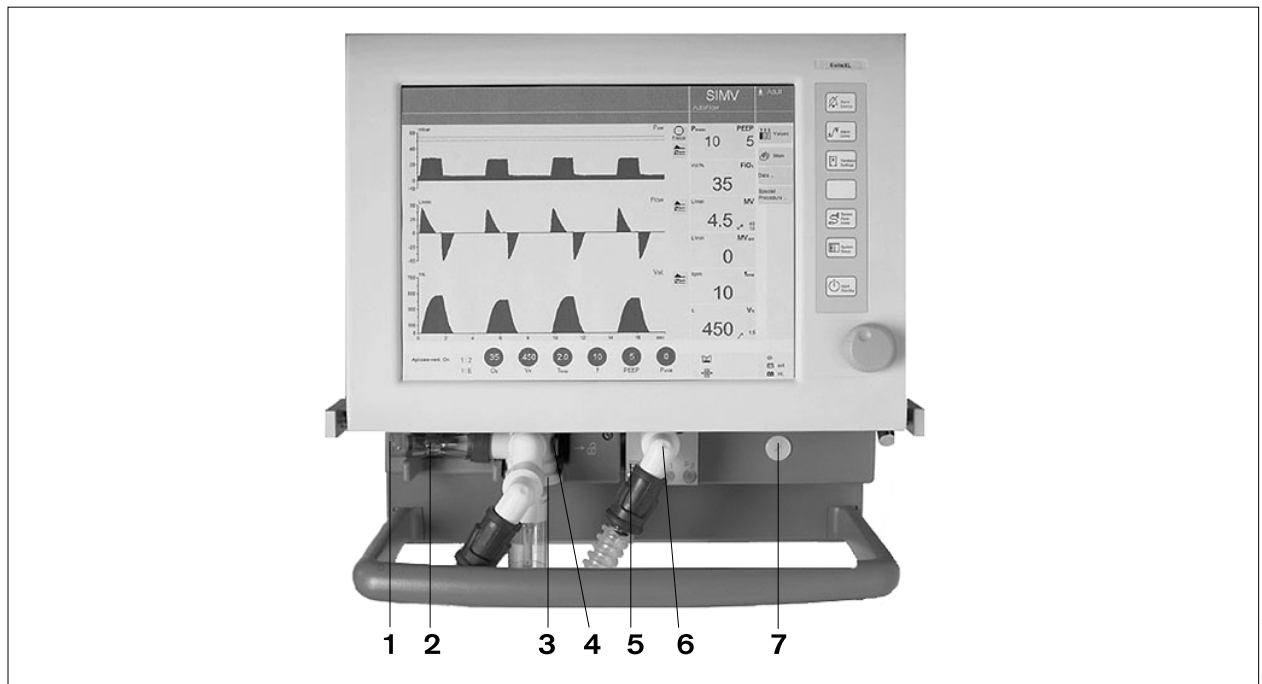



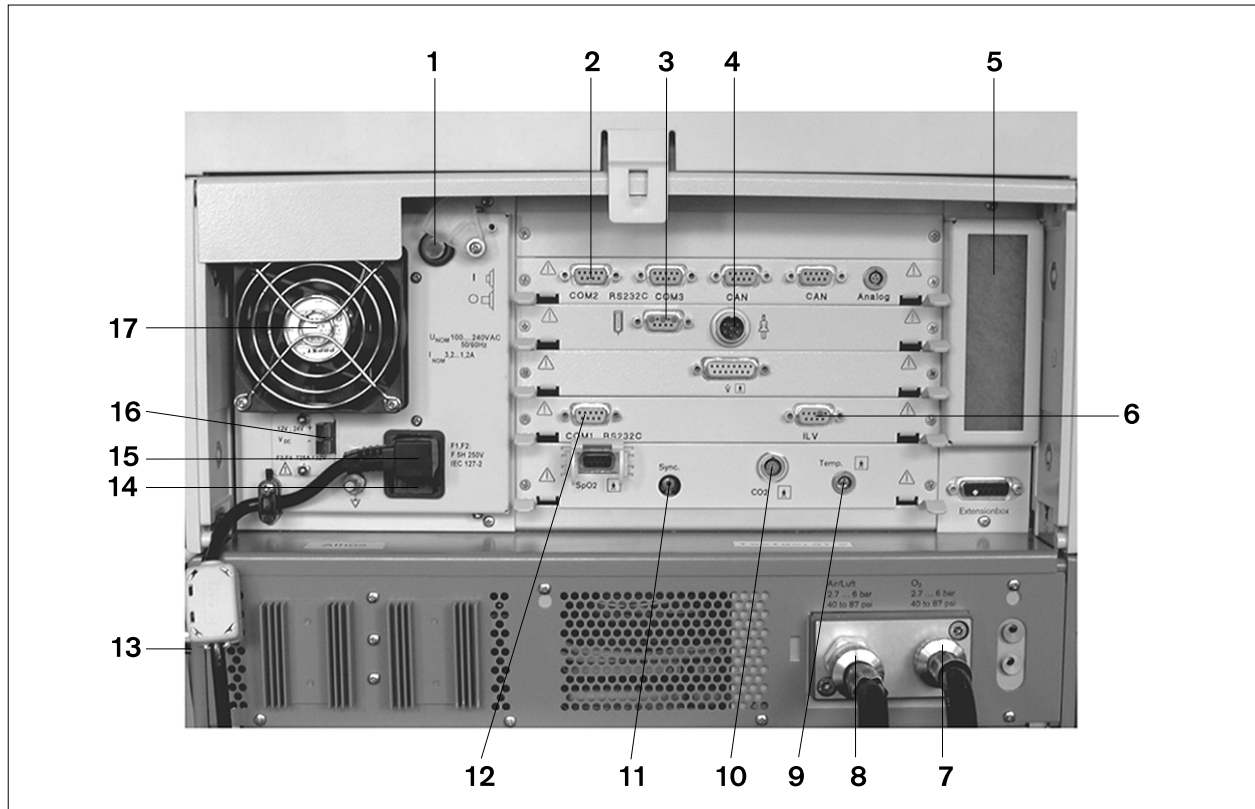

- 1 »  « Gas outlet
(EXHAUST – NOT FOR SPIROMETERS)
- 2 Flow sensor
- 3 Expiration valve with expiration port (GAS RETURN)
- 4 Latch for expiration valve
- 5 Nebuliser connection
- 6 Inspiration port (GAS OUTPUT)
- 7 Locking screw for protective cover
(behind it: O₂ sensor and ambient air filter)

Back panel



Back panel_EvitaXL.tif

- | | |
|---|---|
| <p>1 Power switch with protective flap</p> <p>2 »COM 2«, »COM 3« sockets for RS 232, two CAN interfaces and analogue interface (optional)</p> <p>3 Connection »« for Remote Pad (optional)</p> <p>4 Connection »« for nurse call (optional)</p> <p>5 Cooling air filter</p> <p>6 »ILV« socket for the connecting cable for independent lung ventilation with two units</p> <p>7 Connection for O₂</p> <p>8 Connection for medical air</p> <p>9 »Temp « socket for temperature sensor</p> <p>10 »CO₂ « socket for CO₂ sensor (optional)</p> | <p>11 »Sync.« socket for C-Lock-ECG synchronisation for optional SpO₂ measurement (optional)</p> <p>12 »COM 1 RS 232C« socket for RS 232 interface, e.g. for printer</p> <p>13 Rating plate (not visible) on the left-hand side panel</p> <p>14 Mains fuses</p> <p>15 Connector for power cord</p> <p>16 DC socket</p> <p>17 Fan</p> |
|---|---|

Technical Data

Technical Data	188
Ambient conditions	188
Settings	188
APRV Airway Pressure Release Ventilation	189
ATC Automatic Tube Compensation	189
Breathing Support Package (optional)	190
O2 Therapy (optional)	190
Performance characteristics	191
Measured value displays	192
Computed value displays	194
Monitoring	195
Operating data	196
Equipment outputs	198
DC power supply	200
LUST protocol	201

Technical Data

Ambient conditions

During operation	
Temperature	10 to 40 °C
Atmospheric pressure	700 to 1060 hPa
Rel. humidity	5 to 90 %, without condensation
During storage and transportation	
Temperature	-20 to 60 °C
Atmospheric pressure	500 to 1060 hPa
Rel. humidity	5 to 95 %, without condensation

Settings

Ventilation frequency f	0 to 100/min
Inspiration time T _{insp}	0.1 to 10 s
Tidal volume V _T	
Paediatrics	0.02 to 0.3 L, BTPS*
Accuracy	±10 % of set value, or ±10 mL, whichever is greater.
Adults	0.1 to 2.0 L, BTPS*
Accuracy	±10 % of set value, or ±25 mL, whichever is greater.
Inspiratory Flow	
Paediatrics	6 to 30 L/min
Adults	6 to 120 L/min
Inspiratory pressure P _{insp}	0 to 95 mbar
Inspiratory pressure limit P _{max}	0 to 100 mbar
O ₂ concentration	21 to 100 Vol.%
Accuracy	±5 % of set value, or ±2 Vol.%, whichever is greater.
Positive end-expiratory pressure PEEP or interm. PEEP	0 to 50 mbar
Trigger sensitivity	0.3 to 15 L/min
Pressure assist PASB	0 to 95 mbar
Rise time for pressure assist	0 to 2 s
Independent lung ventilation ILV	
Master	with trigger/without trigger
Slave	synchr./asynchr./inverse I: E

* BTPS
Body Temperature, Pressure, Saturated.
Measured values based on the conditions of the patient's lung:
body temperature 37 °C, steam-saturated gas, ambient pressure.

APRV Airway Pressure Release Ventilation

Inspiration time T_{high}		
Range	0.1 to 10 s	10 to 30 s
Resolution	0.1 s	1 s
Expiration time T_{low}		
Range	0.1 to 10 s	10 to 30 s
Resolution	0.05 s	1 s
Inspiration pressure P_{high}		
Range	0 to 95 mbar	
Resolution	1 mbar	
Expiration pressure P_{low}		
Range	0 to 50 mbar	
Resolution	1 mbar	

ATC Automatic Tube Compensation

Adult mode

Inside tube diameter (ID Ø)	
Range	5 to 12 mm
Resolution	0.5 mm
Degree of compensation (Comp.)	
Range	0 to 100 %
Resolution	1 %

Paediatric mode

Inside tube diameter (ID Ø)	
Range	2.5 to 8 mm
Resolution	0.5 mm
Degree of compensation (Comp.)	
Range	0 to 100 %
Resolution	1 %

Breathing Support Package (optional)

Adult mode

Settings for PPS:

Flow Assist (FlowAssist)

Range	0 to 30 mbar/L/s
Resolution	0.5 mbar/L/s
Corresponds to resistance compensation	0 to 30 mbar/L/s

Volume Assist (Vol.Assist)

Range	0 to 25 mbar/L
Resolution	0.1 mbar/L
Range	25 to 100 mbar/L
Resolution	0.5 mbar/L
Corresponds to compliance compensation	10000 to 10 mL/mbar

Paediatric mode

Settings for PPS:

Flow Assist (FlowAssist)

Range	0 to 30 mbar/L/s
Resolution	0.5 mbar/(L/s)
Range	30 to 100 mbar/L/s
Resolution	5 mbar/L/s
Corresponds to resistance compensation	0 to 100 mbar/L/s

Volume Assist (Vol.Assist)

Range	0 to 100 mbar/L
Resolution	1 mbar/L
Range	100 to 1000 mbar/L
Resolution	10 mbar/L
Corresponds to compliance compensation	1000 to 1 mL/mbar

O2 Therapy (optional)

Settings

Continuous Flow	2 to 50 L/min
O2 concentration	21 to 100 Vol.%
Accuracy	±5 % of set value, or ±2 Vol.%, whichever is greater.

Performance characteristics

Control principle	time-cycled, volume-constant, pressure-controlled
Intermittent PEEP frequency	2 cycles every 3 minutes
Medicament nebulisation	for 30 minutes
Bronchial suction	
Disconnection detection	automatic
Reconnection detection	automatic
Oxygen enrichment	max. 3 minutes
Active suction phase	max. 2 minutes
Final oxygen enrichment	2 minutes
Supply system for spontaneous breathing and ASB max. inspiratory flow	adaptive CPAP system with high initial flow 180 L/min
Equipment compliance	
– with Aquapor EL humidifier and patient tubing system for adults	<2.3 mL/mbar
– with Fisher & Paykel humidifier and patient tubing system for adults	<1.5 mL/mbar
Inspiratory resistance	
– in operation with Aquapor EL humidifier, without CO ₂ cuvette	<1.5 mbar at 60 L/min
– following equipment failure with Aquapor EL humidifier, without CO ₂ cuvette	<6 mbar at 60 L/min
Expiration resistance	
– in operation without CO ₂ cuvette	<4.3 mbar at 60 L/min
– following equipment failure without CO ₂ cuvette	<3.7 mbar at 60 L/min
Dead space volume including CO ₂ cuvette	approx. 9 mL
Additional functions	
Inspiratory relief valve	opens if medical air supply fails (pressure <1.2 bar), enables spontaneous breathing with filtered ambient air
Safety valve	opens the breathing system at 100+5 mbar.

Measured value displays

Airway pressure measurement

Max. airway pressure	P_{peak}
Plateau pressure	P_{Plat}
Pos. end-exp. pressure	PEEP
Mean airway pressure	P_{mean}
Min. airway pressure	P_{min}
Range	-45 to 110 mbar
Resolution	1 mbar
Accuracy	2 % (4 % when displayed in cmH ₂ O)

O₂ measurement in main flow (inspiratory side)

Inspiratory O ₂ concentration FiO ₂	
Range	15 to 100 Vol.%
Resolution	1 Vol.%
Accuracy	±3 Vol.%

Flow Measurement

Minute Volume MV

Spontaneously breathed minute volume MV _{spn}	
Range	0 to 120 L/min, BTPS*
Resolution	0.1 L/min, or for values less than 1 L/min: 0.01 L/min
Accuracy	±8 % of measured value
T _{10...90}	approx. 35 s

Tidal volume V_{T_e}

Spontaneously breathed tidal volume VT _{spn}	
Range	0 to 10 L, BTPS*
Resolution	1 mL
Accuracy	±8 % of measured value

Tidal volume VT_{ASB}

Inspiratory tidal volume during an ASB stroke	
Range	0 to 10 L, BTPS*
Resolution	1 mL
Accuracy	±8 % of measured value

* BTPS
Body Temperature, Pressure, Saturated.
Measured values based on the conditions of the patient's lung:
body temperature 37 °C, steam-saturated gas, ambient pressure.

Frequency Measurement

Breathing frequency f_{total}

Spontaneous breathing frequency f_{spn}

Range	0 to 300/min
Resolution	1/min
Accuracy	± 1 /min
T _{10...90}	approx. 35 s

Breathing gas temperature measurement

Range	18 to 51 °C
Resolution	1 °C
Accuracy	± 1 °C

CO₂ measurement in main flow (optional)

End-expiratory CO₂ concentration $etCO_2$

Range	0 to 100 mmHg or 0 to 13.3 Vol.% or 0 to 13.3 kPa
Resolution	1 mmHg or 0.1 Vol.% or 0.1 kPa
Accuracy	± 2 mmHg ± 5 % of measured value
for 0 to 40 mmHg	
for 40 to 100 mmHg	
T _{10...90}	≤ 25 ms
Warm-up time	max. 3 minutes

CO₂ production $\dot{V}CO_2$

Range	0 to 999 mL/min, STPD*
Resolution	1 mL/min
Accuracy	± 9 % of measured value
T _{10...90}	12 minutes

Serial dead space V_{ds}

Range	0 to 999 mL, BTPS
Resolution	0.1 mL
Accuracy	± 10 % of measured value, or ± 10 mL, whichever is greater.

Dead space ventilation V_{ds}/V_T

Range	0 to 99 %
Resolution	1 %
Accuracy	± 10 % of measured value

* STPD
Standard Temperature, Pressure, Dry.
Measured values based on normal physical conditions: 0 °C, 1013 hPa, dry

Computed value displays

Compliance C

Range	0 to 300 mL/mbar
Resolution	
Range 0 to 99.9 mL/mbar	0.1 mL/mbar
Range 100 to 300 mL/mbar	1 mL/mbar
Accuracy	±20 % of measured value*

Resistance R

Range	0 to 600 mbar/L/s
Resolution	
Range 0 to 99.9 mbar/L/s	0.1 mbar/L/s
Range 100 to 600 mbar/L/s	1 mbar/L/s
Accuracy	±20 % of measured value**

Leakage minute volume MV_{leak}

Range	0 to 99 L/min, BTPS
Resolution	0.1 L/min or for values less than 0.1 L/min: 0.01 L/min
Accuracy	±18 % of measured value
T _{10...90}	approx. 35 s

Rapid Shallow Breathing RSB

Range	0 to 9999 1/(min x L)
Resolution	1/(min x L)
Accuracy	see measurement of V _T and f

Negative Inspiratory Force NIF

Range	-45 to 0 mbar
Resolution	1 mbar
Accuracy	±2 mbar

Curve displays:

Airway pressure PAW (t)	-10 to 100 mbar
Flow (t)	-200 to 200 L/min
Volume V (t)	0 to 2000 mL
Exp. CO ₂ concentration FCO ₂	0 to 100 mmHg or 0 to 14 kPa or 0 to 15 Vol.%
Occlusion pressure P 0.1	0 to 25 mbar

* C-values may be considerably falsified as spontaneous breathing increases; compliance with the measuring accuracy therefore cannot be guaranteed for spontaneous breathing.

** R-values may be considerably falsified as spontaneous breathing increases; compliance with the measuring accuracy therefore cannot be guaranteed for spontaneous breathing.

Monitoring

Expiratory minute volume MV

Upper alarm limit alarm	if the upper alarm limit has been exceeded
Setting range	41 to 0.1 L/min, in 0.1 L/min steps
Lower alarm limit alarm	if the value has fallen below the lower alarm limit
Setting range	0.01 to 40 L/min, in 0.1 L/min steps

Airway pressure PAW

Upper alarm limit alarm	if the "PAW high" value is exceeded
Setting range	10 to 100 mbar
Lower alarm limit alarm	if the value "PEEP +5 mbar" (coupled with the PEEP set value) is not exceeded for at least 96 ms in 2 successive ventilation strokes.

Insp. O₂ concentration FiO₂

Upper alarm limit alarm	if the upper alarm limit is exceeded for at least 20 seconds
Lower alarm limit alarm	if the value falls below the lower alarm limit for at least 20 seconds
Range	both alarm limits are automatically allocated to the set value: under 60 Vol.% at ± 4 Vol.% over 60 Vol.% at ± 6 Vol.%

End-expiratory CO₂ concentration etCO₂ (optional)

Upper alarm limit alarm	if the upper alarm limit has been exceeded
Setting range	0 to 100 mmHg or 0 to 15 kPa
Lower alarm limit alarm	if the value has fallen below the lower alarm limit
Setting range	0 to 99 mmHg or 0 to 14 kPa

Insp. breathing gas temperature

Upper alarm limit alarm	on reaching 40 °C (EvitaXL can also be used without a temperature sensor, if it is not connected when EvitaXL is switched on)
-------------------------	--

Tachypnoea monitoring f_{spn}

Alarm	during spontaneous breathing, when the spontaneous breathing frequency has been exceeded
Setting range	5 to 120/min



Volume monitoring

Lower alarm limit alarm	if the set tidal volume V _T (coupled with the set value V _T) has not been supplied
Upper alarm limit alarm	if the applied tidal volume exceeds the value of the alarm limit, inspiration is interrupted and the expiration valve is opened
Setting range	21 to 4000 mL

Apnoea alarm time

Alarm	if no breathing activity is detected
Setting range	5 to 60 seconds, can be set in 1 second increments

Operating data

Mains power connection	100 V –10 % to 240 V +10 % 50/60 Hz
Current consumption	
at 230 V	max. 1.3 A
at 100 V	max. 3.2 A
Power consumption	typically approx. 125 W
Machine fuses	
Range 100 V to 240 V	F 5 H 250 V IEC 127–2 (2x) (FB) F 6.3 H 250 V IEC 127–2 (2x) (MB)
Protection class	
Unit	Class I
CO ₂ sensor (sensor connected)	Type BF 
Temperature sensor (sensor connected)	Type BF 
Gas supply	
O ₂ gauge pressure	3 bar –10 % to 5.5 bar +10 % at 60 L/min (peak flow 200 L/min)
O ₂ connection thread	M 12 x 1, female
Air gauge pressure	3 bar –10 % to 5.5 bar +10 % at 60 L/min (peak flow 200 L/min)
Air connection thread	M 20 x 1.5, male
Dew point	5 °C below ambient temperature
Oil concentration	<0.1 mg/m ³
Particle size	Dust-free air (filtered with filter size <1 µm)
Gas consumption of control system	Medical air or O ₂ approx. 3.6 L/min
Output for pneum. Medicament nebuliser	Medical air or O ₂ max. 2 bar, max. 10 L/min
Automatic gas switch-over	if one gas fails (inlet pressure <1.5 bar), the device switches to the other gas.
Sound pressure level (for free-field measurement over a reflecting surface)	max. 47 dB (A)
Dimensions (W x H x D)	
Basic machine	530 x 315 x 450 mm
Machine with trolley	580 x 1360 x 660 mm
weight	
Basic machine	approx. 29 kg (incl. shelf)
Electromagnetic compatibility (EMC) (conforming to European Directive 89/336/EEC)	tested in accordance with EN 60601-1-2
Classification as per EC Directive 93/42/EEC Annex IX	II b
UMDNS code	17-429
Universal Medical Device Nomenclature System – Nomenclature for medical devices	

Materials used

Part	Appearance	Material
Ventilation hose	milky, transparent	silicone rubber
Water trap	yellow, transparent	polysulphone
Y piece	yellow, transparent	polysulphone
Connector for temperature measurement	milky, transparent	silicone rubber
Expiration valve		
Housing, closure	white	polyamide
Diaphragm	whitish and grey	silicone rubber and aluminium
CO ₂ cuvette	yellow, transparent	polysulphone with glass windows
Temperature sensor/cable	milky/green or blue	silicone rubber
CO ₂ sensor/cable	grey/grey	polyurethane

For Nurse call (optional)

Pin assignment
6-pin round DIN socket
Floating DC contact

Input voltage max. 40 V DC
Input current max. 500 mA
Switching capacity max. 15 W

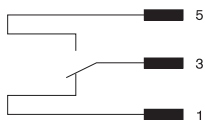

Equipment outputs

Digital outputs

COM 1
as well as
COM 2 and COM 3 (optional)
configurable for:

LUST protocol
Baud rate: 1200, 2400, 4800, 9600, 19200 Baud
Data bits: 7
Parity: even
Stop bits: 1

MEDIBUS protocol
Baud rate: 1200, 2400, 4800, 9600, 19200 Baud
Data bits: 8
Parity: even, odd, no
Stop bits: 1 or 2
(19200 baud are required for transmitting high-speed data, e.g. for the flow curve)

Printer protocol HP Deskjet series 500
Baud rate: 1200, 2400, 4800, 9600, 19200 Baud
Data bits: 8
Parity: no
Stop bits: 1

Pin assignment of the MEDIBUS cable

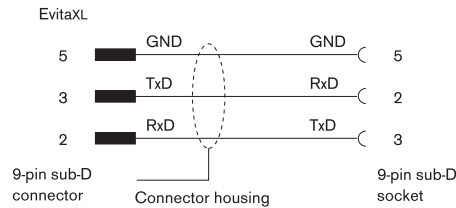

Pin assignment of the printer cable

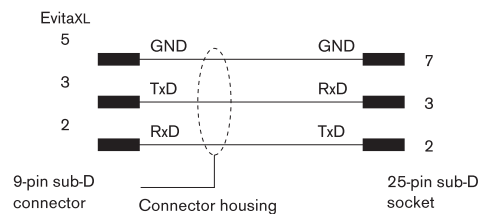

Cable length

up to 15 m

Load impedance

3000 to 7000 Ω

Signal level (for load impedance from 3000 to 7000 Ω)

Low

between 3 and 15 V

High

between -3 and -15 V

Electrical isolation

Ports COM 1, COM 2 and COM 3 (optional) are electrically isolated from the equipment electronics. The test voltage for electrical isolation is 1500 V. Ports COM 2 and COM 3 are not electrically isolated from one another.

Digital output for Independent Lung Ventilation (ILV)

Analogue interface

Voltage level

0 to 4.095 V

Impedance of analogue channels

The output impedance is 200 Ω .

The input impedance of on-line equipment should be not less than 1 M Ω otherwise the output signal will be distorted.

Accuracy

0 V : 0 V to 0.005 V

4.095 V : 4.075 V to 4.115 V

Electrical isolation

The connecting socket is electrically isolated from the equipment electronics. The test voltage for electrical isolation is 1500 V. The analogue channels are not electrically isolated from one another.

Pin assignment

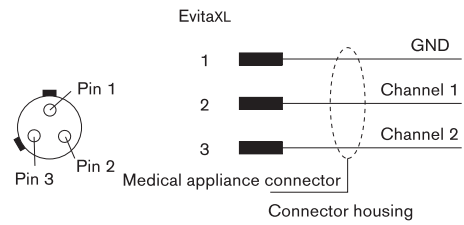

DC power supply

Electrical ratings for the DC socket

DC input voltage	12 or 24 V battery
Input current	
12 V battery	typically 13 A, max. 30 A
24 V battery	typically 6 A, max. 15 A

Performance characteristics

Time bridged following a mains power failure
(with fully operational batteries^{*})

– Fully charged integrated battery	typically 14 minutes; at least 10 minutes
– Two fully charged external 12 V lead-gel batteries (18 43 303) with a capacity of 17 Ah each	typically 2 hours

External batteries^{**}

Type	Lead-gel batteries, sealed maintenance-free
Minimum capacity	
12 V battery	30 Ah (note battery charging current)
24 V battery	15 Ah (note battery charging current)
Max. charging current through the DC power supply (the battery used must be rated for at least this charging current)	
12 V battery	approx. 8 A
24 V battery	approx. 4.5 A
Charging time ^{***} (for 18 43 303), 2 batteries connected in series	
24 V lead-gel battery	typically 8 to 12 hours

Integrated batteries

Type	Lead-gel batteries, sealed maintenance-free
Charging time ^{***}	
DC power supply FB	typically 1.5 to 2.5 hours
DC power supply MB	typically 2.5 to 4 hours

Protection class I

* see "Charge indication and battery charge state", page 172.

** see "Mains power/DC power operation", page 170.

*** see "Charging times", page 172.

LUST protocol

LUST:

List-controlled universal interface driver program compatible with the RS 232 interface in Evita from software version 7.n upwards.

The LUST protocol comprises four different transmission telegrams:

- Identification telegram
- Status telegram
- Data telegram
- Alarm telegram

The first three telegrams are only sent in reply to a request from the external unit. The alarm telegram is sent automatically when an alarm occurs or disappears.

Telegram control

The following ASCII* characters are used to request the individual telegrams:

- "ACK" Request for an identification telegram
- "NAK" Request for a status telegram
- "ENQ" Request for a data telegram

Output of all telegrams can be controlled via certain characters:

- "DC1" (x-on) Enables telegram output
- "DC3" (x-off) Halts output at any time

Following an enable ("DC1"), the interrupted telegram is output again without being adjusted to the actual status. The effect of "DC3" is cancelled by a request for a telegram; the telegram interrupted by "DC1" is lost and the requested telegram is sent.

Output of an alarm telegram can also be controlled:

- "DC2" Enables output of the alarm telegrams
- "DC4" Halts the output of alarm telegrams

Ongoing transmissions are not interrupted by "DC4". This is only possible with "DC3" (x-off).

A telegram request ("ACK", "ENQ" or "NAK") does not re-enable the output of alarm telegrams.

Following a "DC2", the last event is transmitted by the alarms in each case. If alarm events have not occurred, an alarm telegram with all active alarms is requested with each "DC2".

Unknown control characters are ignored.

* For a list of special ASCII characters used, see page 237.

Identification telegram

The identification telegram contains the device designation and a list of all measured values sent in the data telegram. It has the following structure:

Telegram header

"STX" Start character
 050 Identification number
 0 Channel number

Telegram body

The body of the telegram first contains the device name: "ESC EvitaXL"

This is then followed by any number of blocks, each separated by "ESC". Each block contains all the data pertaining to a measured value, each separated by "RS".

Each block has the following structure:

"ESC" (signal No.) "RS" (signal name, long form)

"RS" (signal name, short form) "RS" (unit)

"RS" (minimum) "RS" (maximum)

The following table lists the complete identification telegram:

Signal No.	Signal name long form	Short form	Unit	Minimum value	Maximum value
00	Time	t	h:min	,0.00	23.59
01	Exp. tidal volume	VT _e	L	0.000	2.000
02	Breathing Frequency	f	1/min	„0	240
03	Minute Volume	MV	L/min	,0.00	99.99
04	Peak-pressure	Peak	mbar	„0	120
05	Plateau-pressure	Plat	mbar	,0	99
06	PEEP-pressure	PEEP	mbar	,0	99
07	Minimum-pressure	P _{min}	mbar	-20	99
08	Mean-pressure	Mean	mbar	,0	99
09	Insp. O ₂ -concentration	FiO ₂	%	15	99
10	Compliance	C	mL/mbar	„0.0	255
11	Resistance	R	mbar/(L/s)	„0.0	200
12	Spont. minute volume	MV _s	L/min	,0.00	99.99
13	Spont. frequency	f _s	1/min	„0	240
14	Airway temperature	Temp	deg C	18	45
15	Intrinsic PEEP	P _{intr}	L/min	,0.0	99.99
16	Trapped Volume	V _{trap}	mL	„,0	9999
17	Occlusion Pressure	P _{O1}	mbar	,0.0	99.9
18	End tidal CO ₂ in mmHg	CO ₂ E1	mmHg	,0	99
19	End tidal CO ₂ in kPa	CO ₂ E2	kPa	,0.0	99.9
20	End tidal CO ₂ in %	CO ₂ E3	%	,0.0	99.9
21	CO ₂ Production	CO ₂ P	mL/min	„0	999
22	Dead Space	V _{ds}	mL	„0	999
23	Rel. Dead Space	V _{ds}		„0	999
24	SpO ₂	SpO ₂	%	„0	100
25	Pulse	Pulse	bpm	„0	999
26	Tidal volume ASB	VT ASB	mL	„,0	9999
27	Negative Inspiratory Force	NIF	mbar	-45	,0
28	Rapid Shallow Breathing	RSB	1/L*min	„,0	9999

Leading zeroes (identified by "0.0" or "„0" in the table) are replaced by one or two blanks.

End of telegram

"EOT"

Status telegram

The status telegram contains all settings, alarm limits, ventilation modes and status messages.

It has the following structure:

Telegram header

"SOH" Start character
050 Identification number
0 Channel number

Telegram body

The body of the telegram contains any number of status messages, each separated by "GS". Each status message comprises a number and a name.

"GS" (number of the status message) (message text)

Data, such as settings and alarm limits, are enclosed between "FS" in the status message.

All status messages are listed in the following tables.

Settings

00	date : "FS"dd"FS"-"FS"mm"FS"-"FS"yy"FS"
01	O2 setting-value = "FS"nnn"FS" %
02	Max. inspiratory flow = "FS"nnn"FS" L/min
03	Insp. tidal volume = "FS"n,nnn"FS" L
06	I : E = "FS"nn,n"FS" : "FS"1.0"FS"
06	I : E = "FS"1.0"FS" : "FS"nn,n"FS"
07	Max. breathing pressure = "FS"nnn"FS" mbar
08	Frequency = "FS"nnn,n"FS" 1/min
09	PEEP = "FS"nn"FS" mbar
10	ASB = "FS"nn"FS" mbar
11	Interm. PEEP = "FS"nn"FS" mbar
12	APRV P-low = "FS"nn"FS" mbar
13	APRV P-high = "FS"nn"FS" mbar
14	APRV T-low = "FS"nn,n"FS" s
15	APRV T-high = "FS"nn,n"FS" s
16	Apnoea Time = "FS"nn"FS" s
17	Tachypnoea warning = "FS"nnn"FS" bpm
18	Flow Trigger = "FS"nn,n"FS" L/min
19	Pressure increase rate = "FS"n,nn"FS" s
28	Pinsp = "FS"nnn"FS" mbar
84	Ti = "FS"nn,nn"FS" s
87	Flow Assist = "FS"nnn,n"FS" mbar*s/L
88	Volume Assist = "FS"nnnn,n"FS" mbar/L

Alarm limits

20	MV low limit = "FS"nn,nn"FS" L/min
21	MV high limit = "FS"nn,nn"FS" L/min
25	CO2 upper limit = "FS"nnn"FS"mmHg
25	CO2 upper limit = "FS"nn.n"FS"%
25	CO2 upper limit = "FS"nn.n"FS"kPa
26	CO2 lower limit = "FS"nnn"FS"mmHg
26	CO2 lower limit = "FS"nn.n"FS"%
26	CO2 lower limit = "FS"nn.n"FS"kPa
27	PAWLimit = "FS"nnn"FS" mbar
29	Insp. tidal volume high limit = "FS"n,nnn"FS" L
71	Tdisconnect = "FS"nn"FS" s
80	Puls high limit = "FS"nnn"FS" bpm
81	Puls low limit = "FS"nnn"FS" bpm
82	Saturation O2 high limit = "FS"nnn"FS" %
83	Saturation O2 low limit = "FS"nnn"FS" %

Ventilation Modes

30	Mode IPPV
31	Mode IPPV/ASSIST
34	Mode SIMV
35	Mode SIMV/ASB
38	Mode CPAP
39	Mode CPAP/ASB
40	Mode MMV
41	Mode MMV/ASB
42	Mode APRV
43	Mode SYNCHRON MASTER
44	Mode SYNCHRON SLAVE
45	Mode Apnoea Ventilation
48	Mode BIPAP
49	Mode BIPAP/ASB
60	Mode SIMV/AutoFlow
61	Mode SIMV/ASB/AutoFlow
62	Mode IPPV/AutoFlow
63	Mode IPPV/ASSIST/AutoFlow
64	Mode MMV/AutoFlow
65	Mode MMV/ASB/AutoFlow
66	Mode ASYNCHRON MASTER
67	Mode CPAP/PPS
68	Mode BIPAP/ASSIST
69	IV – Invasive ventilation
70	NIV – Non-invasive ventilation

Status messages

24	Flow monitoring on
24	Flow monitoring off
50	Audio alarm inactive on
50	Audio alarm inactive off
51	Nebuliser on
51	Nebuliser off
53	O2 calibration on
53	O2 calibration off
54	O2 monitoring on
54	O2 monitoring off
55	Suction on
55	Suction off
56	Flow calibration on
56	Flow calibration off
57	CO2 calibration on
57	CO2 calibration off
58	CO2 monitoring on
58	CO2 monitoring off
85	SpO2 monitoring on
85	SpO2 monitoring off
97	Neonates
98	Adult
99	Paediatric

End of telegram

"EOT"

Data telegram

The actual measured values defined by the identification telegram are transmitted in the data telegram. Invalid measured values contain dashes instead of numerical values. In addition, the data telegram also contains all the messages in the status telegram which have changed since the last status or data telegram.

The telegram has the following structure:

Telegram header

"SOH" Start character
 050 Identification number
 0 Channel number

Telegram body

The body of the telegram contains all the measured values defined in the identification telegram and any number of status messages. The number of digits for the measured values is defined in the identification telegram and does not exceed five. Commas are also transmitted, leading zeroes are replaced by blanks.

"ESC" (signal number) (measured value)
 "GS" (number of the status message) (message text)

Alarm telegram

Alarm telegrams cannot be requested. They are transmitted automatically as soon as the alarm status changes. Automatic transmission of alarms can, however, be activated and deactivated, see Telegram control on page 201.

The individual messages are output

- when an alarm occurs,
- when the alarm status is cancelled.

The alarm telegram has the following structure:

Telegram header

"BEL" Start character
 050 Identification number
 0 Channel number

Telegram body

"ESC" (alarm/warning/advisory) (status)
 (alarm number) (alarm text)

The significance of the individual fields is as follows:

01	Device failure
02	Air supply down
03	O2 supply down
04	pressure meas. inop
05	O2 measurement inop
06	flow measurement inop
07	mixer inop
08	exp. valve inop
09	fan 1 defect
10	temperature meas. inop
12	temperature high
13	flow sensor ?
14	PEEP high
15	CO2 measurement inop
16	CO2 sensor ?
17	clean CO2 cuvette
18	CO2 zero ?
22	apnoea

23	FiO2 high
24	FiO2 low
25	MV low
26	MV high
27	airway pressure low
28	airway pressure high
29	fail to cycle
30	high frequency
32	volume not constant
33	ASB > 4 s
34	etCO2 high
35	etCO2 low
36	air supply pressure high
37	air supply high
38	apnoea ventilation
39	Insp. hold interrupted
40	loss of data
41	Flow monitoring off
42	Monitoring FiO2 off
43	Monitoring CO2 off
44	Monitoring SpO2 off
45	O2 supply high
46	fan 2 defect
47	malfunction fan 2
48	malfunction fan 1
49	SpO2 low
50	SpO2 high
51	pulse low
52	pulse high
53	no pulse
54	SpO2 sensor ?
55	SpO2 meas. inop
57	battery not loaded
58	battery only for 2 min.
59	int. battery activated
60	ext. battery wrong
61	PEEP valve inop
62	neo. flow meas. inop
63	standby activated
64	nebuliser on
65	tidal volume high
67	check evita
68	frequency ILV Slave ?
69	pressure limited
70	ILV sync. inop
71	MEDIBUS inop
73	ASB > 1.5 s
74	Leakage
75	neo.flow monitoring off
76	neo.flowsensor unsuitable
77	nebuliser off
78	PPS-insp. >1.5 s
79	PPS-insp. >4 s

80	ASB > T _{insp}
81	backup ventilation
82	Exsp. hold interrupted
83	neo. flow?
84	Apnoea alarm off
85	MV low alarm off
86	VT high alarm off
87	Evita Remote error
88	Tube obstructed
89	Ext. Flow compensated
90	Error multi functional board
91	Ambient pressure sensor?

End of telegram

"EOT"

Description

Ventilation Modes	208
Volume-controlled ventilation with PLV and AutoFlow®	208
Sigh	210
SIMV	211
MMV	212
BIPAP	213
BIPAPAssist	215
APRV	215
ASB	216
PPS (optional)	217
Measurements	218
Flow measurement	218
Measurement principles	219
Automatic leakage compensation	220
Tube compensation ATC	221
Weaning parameters	224
Intrinsic PEEP – PEEP _i	226
Low Flow PV-Loop	227
Insp. O ₂ concentration during medicament nebulisation	228
Screen configurations	229
Abbreviations	232
Symbols	234
Bibliography	235
Special ASCII characters used	237

Ventilation Modes

Volume-controlled ventilation with PLV and AutoFlow®

AutoFlow is a new additional function that regulates inspiratory flow during the mandatory ventilation stroke in the constant-volume ventilation modes IPPV, SIMV and MMV. To explain the improvement achieved by this function, the conventional methods are explained first:

Classic constant-volume mandatory ventilation stroke

In mandatory ventilation strokes without AutoFlow, the »Insp.Flow« parameter restricts the inspiration flow. If the inspiration flow is so high that the set tidal volume V_T is attained before the inspiration time T_{insp} has fully elapsed, the inspiration valve closes, and the breathing gas supply stops. The expiration valve also remains closed until the end of the inspiration time T_{insp} . This phase, the inspiratory pause, can be identified in the curve $P_{AW}(t)$ as the plateau P_{Plat} .

This type of mandatory ventilation stroke, which for technical reasons is found in the same form in almost all intensive care ventilators, has two serious drawbacks:

- If the lungs are extremely non-homogeneous, the pressure peaks can lead to the overdistension of specific lung areas, and
- the limited inspiration flow and closed inspiration and expiration valves during the inspiratory pause can cause the patient to "fight" the machine.

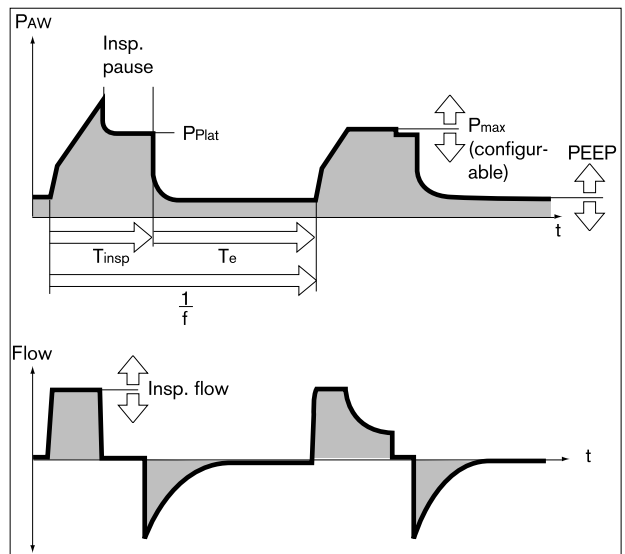

Manual pressure limitation P_{max}

EvitaXL can prevent pressure peaks, while maintaining the set tidal volume V_T , by means of the pressure limit P_{max} . The tidal volume V_T remains constant as long as a pressure plateau P_{Plat} is still detectable and the flow curve shows a brief zero flow between inspiration and expiration.

EvitaXL performs this function by reducing the Insp. Flow on reaching the set P_{max} value. If the tidal volume V_T can no longer be attained with the selected pressure P_{max} , due to reduced compliance, the alarm "Volume not constant" is automatically generated.

AutoFlow®

The AutoFlow function can be activated in the »Add. settings« menu. AutoFlow takes over the task of setting both »Insp. Flow« and »P_{max}«. Once AutoFlow has been activated, P_{max} and Insp. Flow can no longer be set.

With AutoFlow, the inspiration flow is automatically adjusted to changes in lung conditions (C, R) and to the spontaneous breathing demand of the patient.

Always set the alarm limit »P_{AW} $\sqrt{\text{f}}$ « in order to generate an alarm in the event of an increase in airway pressure with reduced compliance.

The maximum applied pressure is limited to 5 mbar below the upper pressure limit.

Typically, the selected inspiration time T_{insp} is much longer than the lung filling time. The inspiration pressure P_{insp} corresponds to the minimum value calculated from the tidal volume V_T and compliance C of the lung.

The inspiration flow is automatically controlled so that there is no pressure peak caused by the resistances of the tube and the airways. The plateau pressure P_{Plat} varies with changes in compliance C, as is normal in all constant-volume ventilation strokes. With AutoFlow these variations occur in maximum steps of 3 mbar between ventilation strokes.

If the tidal volume V_T is reached (inspiration flow = 0) before the inspiration time T_{insp} has fully elapsed, the control system for the inspiration and expiration valves ensures that the patient can breathe in and out during the remaining inspiration time, even during a constant pressure plateau P_{Plat}.

If the patient breathes in or out during mandatory inspiration, the plateau pressure P_{Plat} is not changed for this ventilation stroke: only the inspiration and expiration flow are adapted to the patient's demand. The individually applied tidal volume V_T may differ from the set tidal volume V_T in specific ventilation strokes, but on average over time a constant tidal volume V_T is supplied.

Any overstepping of the tidal volume V_T can be limited by the alarm limit »V_{Ti} $\sqrt{\text{f}}$ «. If the set alarm limit is exceeded once, EvitaXL generates an advisory message(!); if the alarm limit is exceeded three times in a row, it generates an alarm (!!!). In the above examples the volume is actively limited to the alarm limit value »V_{Ti} $\sqrt{\text{f}}$ « by switching over to the PEEP level.

- **Set the alarm limits MV $\sqrt{\text{f}}$ and MV $\sqrt{\text{r}}$ adequately in order to avoid excessive or insufficient flow following rapid changes in compliance.**

A set inspiration time T_{insp} shorter than the lung filling time can be recognised from the flow curve: the flow at the end of the inspiration time has not dropped to zero. In this case, it must be decided whether the current condition of the patient permits prolongation of the inspiration time T_{insp} in order to reduce the peak pressure even further.

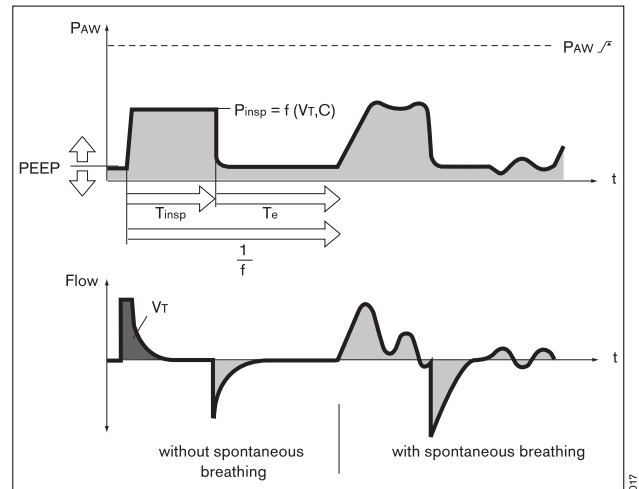

Sigh

This effect can also be caused during ventilation, e.g. due to a build-up of secretion. In this situation, the pressure is limited by the alarm limit »PAW \nearrow «. The pressure rise stops 5 mbar below the alarm limit »PAW \nearrow «, and the alarm »Volume not constant« is only given when the set tidal volume VT is not longer applied.

The start of mandatory inspiration can be synchronised with the patient's own efforts with the aid of the variable Flowtrigger. Only in IPPV mode can Flowtrigger be fully switched off (IPPVAssist -> IPPV).

The steepness of the pressure rise from the PEEP level to the inspiration level can be even more closely adapted to the needs of the patient in SIMV and MMV modes by means of the pressure rise time »Ramp«.

Start-up procedure with AutoFlow

On switching on the AutoFlow function, EvitaXL applies the set tidal volume VT through a volume-controlled ventilation stroke with minimum inspiration flow and subsequent inspiratory pause.

The plateau pressure P_{Plat} calculated for this ventilation stroke serves as start-up inspiration pressure for the AutoFlow function.

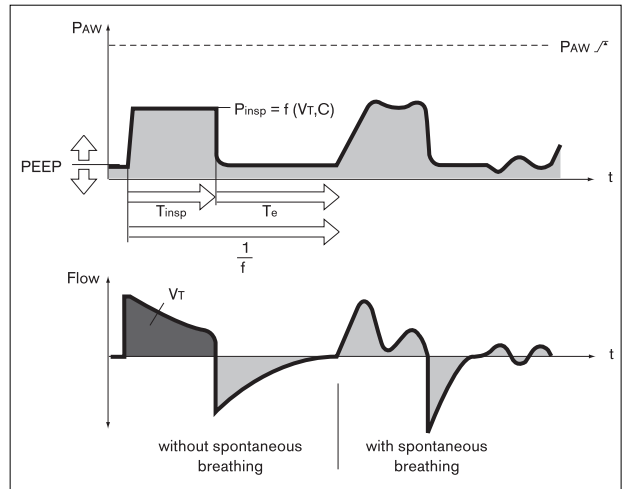

Sigh

"Sigh" is effective in the form of intermittent PEEP in the IPPV, IPPVAssist and ILV modes.

The purpose of expiratory sigh during ventilation is to open collapsed areas of the lung, or to keep open "slow" areas of the lung.

Since atelectatic alveoli have a longer time constant – also caused by obstructed bronchioles – increased airway pressure maintained over a longer period is required to open them.

In EvitaXL the activated sigh has an expiratory effect with an intermittent PEEP for two ventilation strokes every 3 minutes.

The average airway pressure is higher, and a longer filling time is normally available.

To avoid overinflation of the lung, the pressure peaks during the sigh phase can be limited by pressure limitation P_{max} , without impairing the sigh function.

During the sigh phase, the "Volume not constant" alarm is disabled.

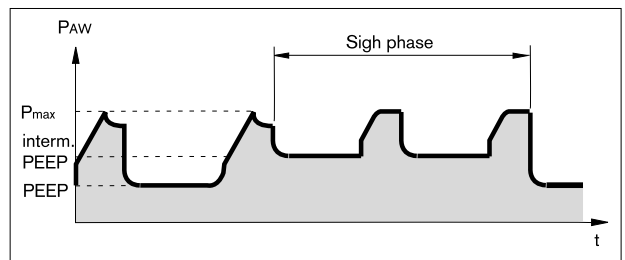

SIMV

Synchronised Intermittent Mandatory Ventilation

Combination of machine ventilation and spontaneous breathing.

SIMV enables the patient to breathe spontaneously in regular prescribed cycles, with the mechanical mandatory ventilation strokes providing a minimum ventilation during the remaining cycles. The minimum ventilation is controlled by the two set values tidal volume (V_T) and ventilation frequency (f) and is determined from the product of $V_T \times f$.

The ventilation pattern results from the set values tidal volume V_T , insp. flow, frequency f and inspiration time T_{insp} . To prevent the mandatory ventilation stroke being applied during spontaneous expiration, the Flowtrigger of the machine ensures that the ventilation stroke is triggered in synchrony with the patient's spontaneous inspiratory effort within a "trigger window".

The "trigger window" is 5 seconds long in adult mode and 1.5 seconds long in paediatric mode. For expiration times shorter than 5 seconds or 1.5 seconds, the "trigger window" covers the entire expiration time.

Since the synchronisation of the mandatory ventilation stroke reduces the effective SIMV time, which would result in an undesirable increase in effective IMV frequency, EvitaXL prolongs the subsequent breathing time by the missing time difference ΔT – thus preventing an increase in SIMV frequency. The frequency parameter f remains constant. This parameter, in combination with the tidal volume V_T , sets the minimum ventilation. If the inspiratory volume of the patient is considerable at the beginning of the "trigger window", the machine reduces the subsequent mandatory ventilation stroke by shortening the time for the inspiratory flow phase and the inspiration time. In this way, the tidal volume V_T remains constant, and overinflation of the lungs is avoided.

During the spontaneous breathing phases, the patient can be assisted with pressure by ASB pressure support.

In the further weaning process, the frequency f on the ventilation unit is further reduced, thereby prolonging the spontaneous breathing time, until finally the required minute volume is entirely covered by spontaneous breathing.

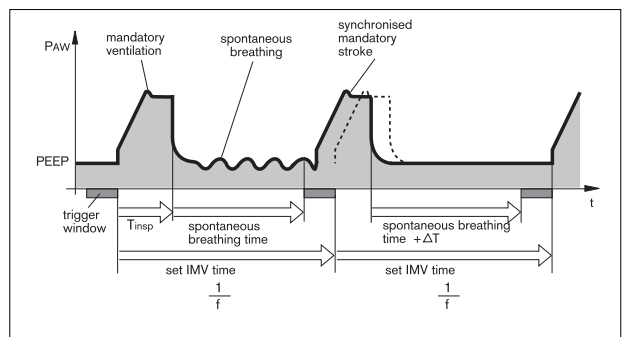

MMV

Mandatory Minute Volume Ventilation

In contrast to SIMV, the MMV ventilation mode gives mandatory ventilation only if spontaneous breathing is not yet sufficient and has fallen below a pre-selected minimum ventilation. This minimum ventilation is controlled by the two set values tidal volume V_T and frequency f , and results from the product $V_T \times f$.

Unlike SIMV, the mandatory strokes are not given regularly but only in cases of insufficient ventilation.

The frequency of mandatory strokes is determined by the level of spontaneous breathing:

if spontaneous breathing is sufficient, mandatory strokes are not used. If spontaneous breathing is not sufficient, intermittent mandatory strokes of the set tidal volume V_T are applied. If there is no spontaneous breathing at all, the mandatory strokes are applied at the set frequency f .

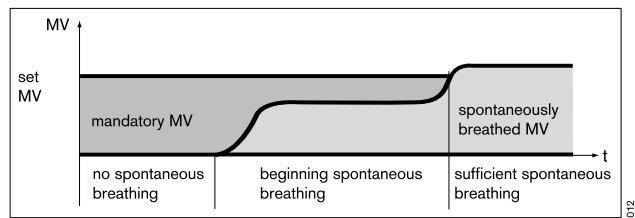
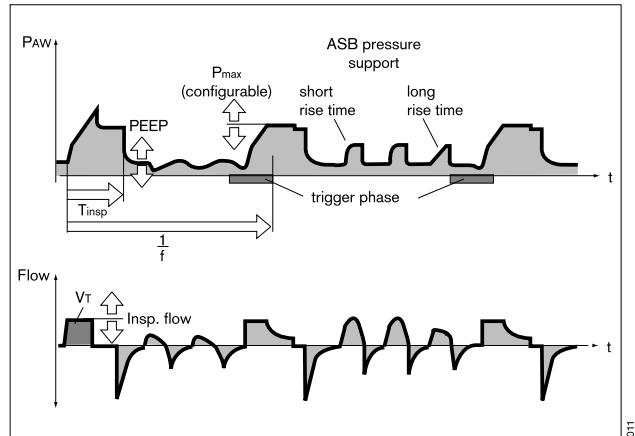

EvitaXL continuously balances the difference between spontaneous breathing and the set minimum ventilation. As soon as the balance becomes negative, because spontaneous breathing is no longer sufficient, EvitaXL applies a mandatory ventilation stroke at the set tidal volume V_T , so that the balance is positive again.

Experience shows patients breathe very irregularly. Phases of shallow breathing alternate with phases of tachypnoea and large respiratory effort. In order to allow for these individual fluctuations, the balancing process also takes account of the extent by which the set minimum ventilation has been exceeded.

This value is progressively reduced to zero by EvitaXL within a maximum time of 7.5 seconds after apnoea.

In this way, the response time of EvitaXL is automatically adapted to the preceding cycle of spontaneous breathing before activating mandatory ventilation:

If this spontaneous breathing was close to the minimum ventilation, EvitaXL responds rapidly within the cycle time ($1/f$). However, if the patient's spontaneous breathing was much higher than the set minimum ventilation, EvitaXL tolerates a longer breathing pause. In extreme cases of sudden apnoea after a phase of heavy spontaneous breathing, the response time will be 7.5 seconds plus the trigger time, with a minimum of one cycle time ($1/f$).

Response times longer than 15 seconds may only occur if the minimum ventilation with a very low frequency f is set to correspondingly low values.

In this case, EvitaXL triggers an apnoea alarm, which is cancelled again as soon as the mandatory ventilation strokes have been applied. If the set cycle time ($1/f$) is longer than the $T_{Apnoea} \sqrt{f}$ alarm limit and if there is no spontaneous breathing between the mandatory ventilation strokes, the apnoea alarm will be triggered regularly.

Example: $f = 3/\text{min} = \text{cycle time } (1/f) = 20 \text{ seconds}$
 $T_{Apnoea} \sqrt{f} = 15 \text{ seconds}$

This system is designed to prevent mandatory ventilation being prematurely triggered in the event of irregular spontaneous breathing, whilst at the same time giving an alarm for any long period of minimal ventilation.

BIPAP

Biphasic Positive Airway Pressure

The BIPAP ventilation mode is a pressure/time-cycled ventilation mode in which the patient can always breathe spontaneously. BIPAP is therefore often described as a time-cycled alternation between two CPAP levels.*

The time-cycled change of pressure gives controlled ventilation, which corresponds to pressure-controlled ventilation PCV. However, the constant option of spontaneous breathing allows the transition from controlled breathing to independent spontaneous breathing to take place smoothly via the weaning phase, without requiring any change the ventilation mode. To adapt easily to the patient's spontaneous breathing pattern, the change-over from expiratory pressure level to inspiratory pressure level, and also the change-over from inspiratory pressure level to expiratory pressure level, are synchronised with the patient's spontaneous breathing.

The frequency of the change-over is kept constant, even when synchronisation occurs via a "trigger window" with fixed time constant.

The "trigger window" is 5 seconds long in adult mode and 1.5 seconds long in paediatric mode. For expiration times shorter than 5 seconds or 1.5 seconds, the "trigger window" covers the entire expiration time. At P_{insp} level, the "trigger window" is $1/4 \cdot T_{insp}$ seconds long.

As recent clinical research** has shown, this smooth adaptation to the patient's spontaneous breathing requires less sedation, so that the patient returns to spontaneous breathing more rapidly.

* Bibliography [3], [4], [7], [11], [12], page 235

** Bibliography [8], page 235

As in all pressure-controlled ventilation modes, the patient is not prescribed a fixed tidal volume (VT).

The tidal volume results principally from the pressure difference between the settings for PEEP and P_{insp}.

Changes in lung compliance and airways, as well as active breathing by the patient can lead to changes in tidal volume. This is a desired effect in this ventilation mode.

With the knowledge that the tidal volume, and therefore the minute volume, are not constant, the alarm limits for minute volume must be adjusted with care.

The display of the expiratory measured tidal volume V_{Te} must be used to set the required difference between the two pressure levels.

As with SIMV, the time pattern is set using the basic setting parameters of frequency f and inspiration time T_{insp}. The resultant inspiration and expiration times are calculated by EvitaXL and displayed in the lower half of the screen below the curve setting. The lower pressure level is set with the PEEP parameter, while the upper level is set with P_{insp}.

When switching over from SIMV to BIPAP mode, and retaining the time pattern, only the P_{insp} setting needs to be changed.

The steepness of the increase from the lower pressure level to the upper pressure level is controlled by the »Ramp« setting. The effective time for the increase in pressure cannot become greater than the set inspiratory time T_{insp}.

This precaution ensures that the upper pressure level P_{insp} is reached safely during inspiration. The transition from controlled ventilation via the weaning phase to fully spontaneous breathing is achieved by a gradual reduction of inspiratory pressure P_{insp} and/or frequency f.

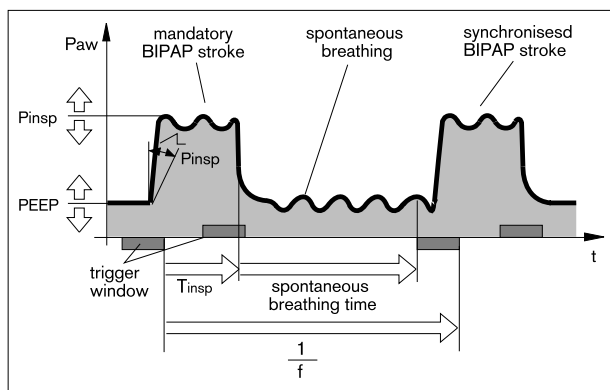

022

BIPAPAssist

Biphasic Positive Airway Pressure Assisted

Pressure-controlled, assisted ventilation

For all patients, from those unable to breathe spontaneously to those breathing spontaneously before being weaned off the ventilator.

The inspiratory strokes are the same as for BIPAP, except that the change from P_{insp} to PEEP is not synchronised with expiration by the patient.

The duration of P_{insp} depends on T_{insp} . The patient can breathe spontaneously throughout the ventilation process.

Every spontaneous breathing activity by the patient at the lower pressure level triggers a synchronised inspiratory stroke.

A non-synchronised inspiratory stroke is triggered by the machine at the latest upon expiry of the inspiration time defined by »f« and » T_{insp} «.

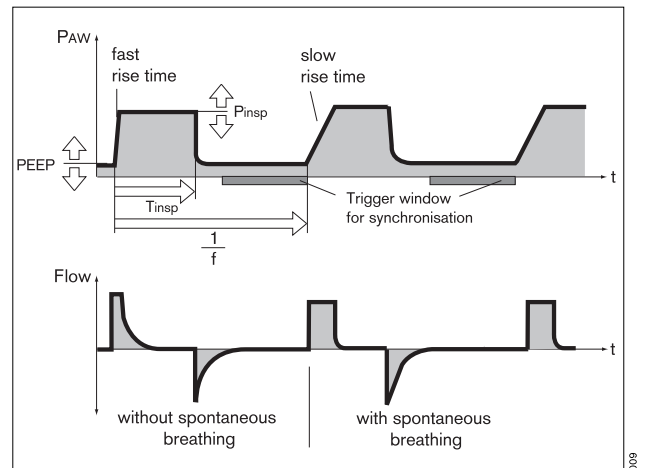

APRV

Airway Pressure Release Ventilation

Spontaneous breathing under continuous positive airway pressure with brief pressure release. The patient breathes spontaneously at a high pressure level P_{high} for an adjustable length of time T_{high} . For very short expiration times T_{low} , EvitaXL switches to a low pressure level P_{low} . The normal lung areas are emptied, but the "slow" lung areas only change volume to a lesser extent.*

In this way, the ventilation/perfusion ratio can be improved for patients with a poor gas exchange.

The steepness of the increase from the lower pressure level to the upper pressure level is controlled by the »Ramp« setting. The effective time for the increase in pressure cannot become greater than the set time T_{high} .

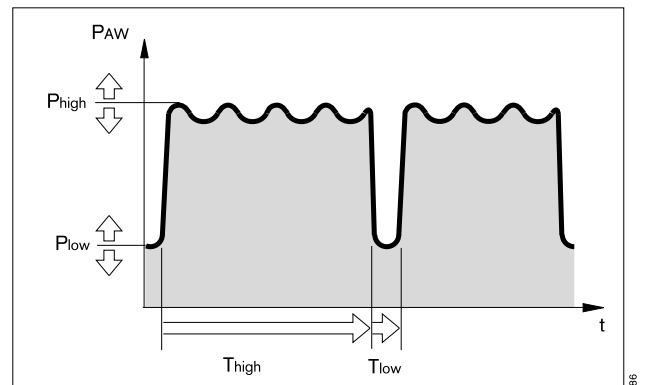

* Bibliography [6], [7], [8], [9], page 235

ASB

Assisted Spontaneous Breathing

Pressure support for insufficient spontaneous breathing.

The function of the machine in assisting insufficient spontaneous breathing is similar to that of the anaesthetist who manually assists and monitors the patient's spontaneous breathing by feeling the breathing bag.

The machine takes over part of the inhalation function, with the patient maintaining control of spontaneous breathing.

The CPAP system supplies the spontaneously breathing patient with the breathing gas, even if the inspiration effort is weak.

The pressure support of the ASB system is started:

- when the spontaneous inspiration flow reaches the set value of the Flowtrigger, or at the latest
- when the spontaneous inspired volume exceeds 25 mL (12 mL in paediatric mode).

The machine then produces an increase in pressure up to the preselected ASB pressure P_{ASB} , which is adjustable to the breathing requirement of the patient.

The time for this pressure increase is adjustable from 64 milliseconds to 2 seconds.

With a rapid increase in pressure, EvitaXL supports the patient's insufficient spontaneous breathing with a high peak flow.

With a slow increase in pressure, EvitaXL begins gently with a low inspiratory flow. The patient must increase his/her breathing effort.

With the patient adjusted pressure increase and ASB pressure P_{ASB} the patient defines via his/her breathing activity the required inspiration flow, which can rise in 8 ms to 2 L/s.

ASB is terminated:

- when the inspiration flow returns to zero during phase I, i.e. when the patient exhales or fights the ventilator, or
- when the inspiration flow in phase II falls below a certain ratio of the maximum value previously supplied: for adult ventilation: 25 % Insp. Flow
for paediatric ventilation: 25 % Insp. Flow
or
- at the latest after 4 seconds (1.5 seconds in paediatric ventilation) if the two other criteria have not come into operation.
If this time criterion occurs three times in succession, EvitaXL gives an alarm and warns of a possible leak in the ventilation system.

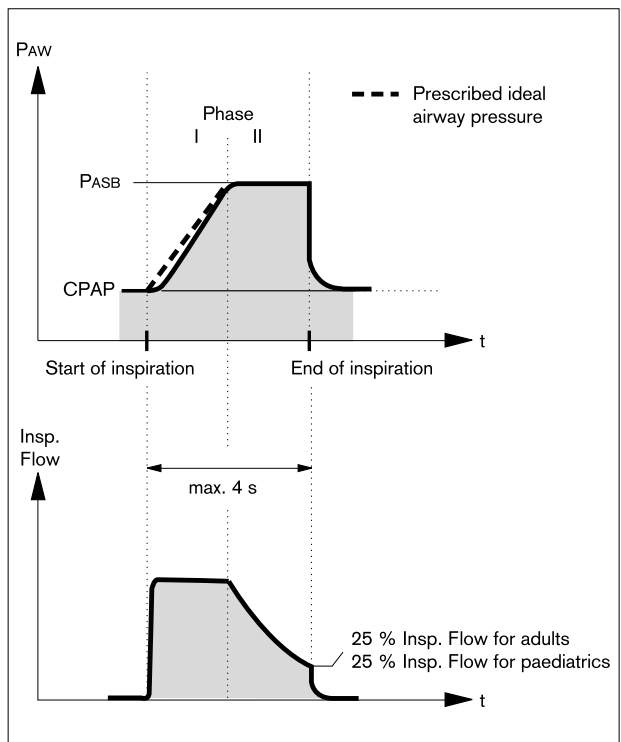

PPS (optional)

In ventilation mode »PPS«, EvitaXL supports the patient's spontaneous breathing proportionally to the breathing effort. If the patient breathes strongly, EvitaXL supports this effort with high pressure; shallow breathing is supported with low pressure. Mechanical support is omitted altogether if there is no spontaneous breathing. Monitoring of apnoea and minute volume must therefore be set appropriately.

Ventilation in PPS mode can be compared to power-assisted steering in a motor car: every turn of the steering wheel is supported by a servo-amplifier so that less effort is required by the driver than when driving without power-assisted steering. On the other hand, there is no response from the power-assisted steering if the steering wheel is not turned at all.

The degree of support in PPS mode can be set separately according to the resistive and elastic components.

The amount of resistive breathing effort to be undertaken by EvitaXL is determined by the user through the resistive FlowAssist component.

EvitaXL increases the ventilation pressure as the patient breathes in.

For a detailed description of PPS in the literature, refer to "Proportional Assist Ventilation", page 235 [20].

Example:

If FlowAssist is set to 5 mbar/L/s, a resistance of 5 mbar/L/s will be compensated. The resistive support pressure is calculated by EvitaXL as follows:

$$\Delta P_{AW} = \text{FlowAssist} * \text{Flow}$$

With the help of the elastic component Vol.Assist, the user can determine the amount of elastic breathing effort to be undertaken by EvitaXL. This support is only effective during inspiration.

Example:

If Vol.Assist is set to 10 mbar/L, the elastic breathing effort will be compensated for a compliance of 100 mL/mbar. The elastic support pressure is calculated by EvitaXL as follows:

$$\Delta P_{AW} = \text{Vol.Assist} * V_{Ti}$$

The actual ventilation pressure is equal to the sum of the resistive and elastic components.

The airway pressure PAW, tidal volume VT and the inspiration time are monitored by EvitaXL during inspiration.

The maximum airway pressure is limited to $PAW \sqrt{f} - 5$ mbar. The advisory message "Pressure limited !" is displayed.

The maximum inspiratory tidal volume is limited to the upper alarm limit » $V_{Ti} \sqrt{f}$ «.

Inspiration is interrupted if the alarm limit is exceeded and the alarm message "Tidal volume high !!!" is displayed.

The maximum inspiration time is limited to 4 s (1.5 s in paediatric or neonatal mode). If the time is exceeded, inspiration will be interrupted and the alarm message "PPS-Insp. > 4 s !!!" (or the advisory message "PPS-Insp. > 1.5 s !") is displayed.

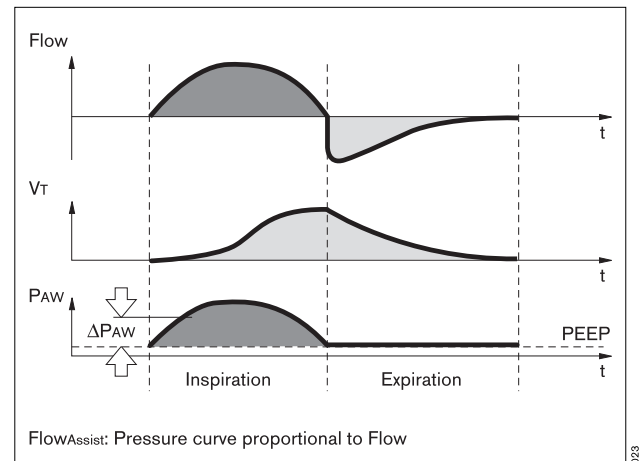

023

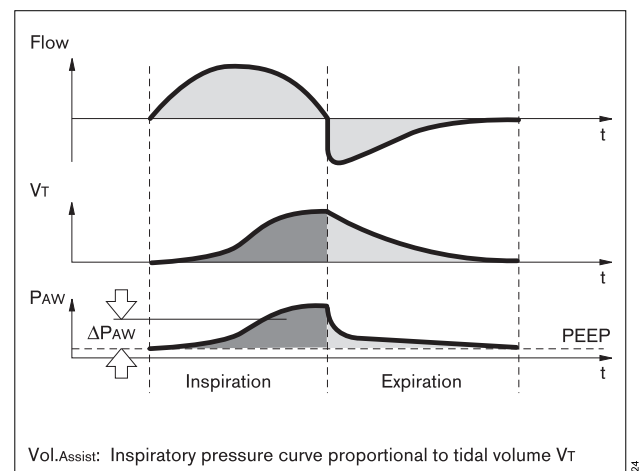

024

Measurements

Flow measurement

Regardless of whether ventilation is volume-controlled or pressure-controlled, positive pressures are generated in both the breathing system and patient lung during the inspiration phase.

Depending on the ratio of lung compliance to hose system compliance, the volume delivered by the ventilator is distributed to the patient's lung and to the hose system installed between the ventilator and patient.

Deviations in the measured expiration flow and derived values, such as the minute volume and breath volume, are low for adult patients, due to their relatively high lung compliance in relation to the much lower compliance of the ventilation hoses.

However, since only the volume attained and surrendered by the lung is relevant to the efficiency of ventilation, and since larger differences are possible during paediatric ventilation, EvitaXL provides basic compensation for hose compliance during ventilation.

Compensation of the effect of hose system compliance

During the device check before ventilation, EvitaXL determines the compliance of the ventilation hoses and then compensates for the effect of compliance on volumetric flow measurement during ventilation.

Depending on the airway pressure, EvitaXL increases the tidal volume by the amount that remains in the ventilation hoses.

In addition to hose system compliance, flow/volume measurement is also influenced by the ambient factors of temperature and humidity, as well as by leaks in the hose system. These factors are taken into account by EvitaXL and the settings and measured values are corrected accordingly.

Conversion according to ambient conditions

The volume occupied by a gas depends on the ambient conditions of temperature, pressure and humidity. In lung physiology, the minute volume and tidal volume are related to the ambient conditions in the lung: 37 °C body temperature, pressure in the lung, 100 % relative humidity.

The flow and volume values measured under these conditions are marked with BTPS*. Medical gases from cylinders or from the central supply are dry (approx. 0 % rel. humidity) and are delivered at 20 °C by the ventilator. The flow and volume values measured under these conditions are marked with NTPD**.

* BTPS = Body Temperature, Pressure, Saturated.

** NTPD = Normal Temperature Pressure Dry.

The difference between measured values under NTPD and BTPS conditions is typically approx. 12 %.

Example: heating up 500 mL tidal volume NTPD to 37 °C and moistening it to 100 % rel. humidity produces 564 mL BTPS. EvitaXL doses the tidal volume so that the set tidal volume under BTPS is effective in the lung.

The expiratory measurement is performed on the basis of saturated gases at 30 °C.

Measurement principles

Flow Measurement

The expiratory flow is measured with a hot-wire anemometer. The energy needed to keep the hot wire at a temperature of 180 °C represents the flow flowing through the sensor and cooling the hot wire.

O₂ measurement

The oxygen measurement is based on the principle of a galvanic cell. The monitored gas diffuses through a membrane into the electrolyte in the sensor. The electrolyte contains a working electrode and a reference electrode. The oxygen is reduced electrochemically and the resultant current is proportional to the O₂ partial pressure in the gas.

CO₂ measurement

CO₂ is measured in the main stream and is based on an absorption measurement. A spectrum is output by a light source while two detectors register the characteristic absorption spectrum and generate electrical signals as a function of the CO₂ concentration. These signals are evaluated and displayed. Condensation is prevented by heating the CO₂ measuring unit.

Automatic leakage compensation

EvitaXL determines the difference between the delivered flow on the inspiration side and the measured flow on the expiration side. This difference provides a measure of the amount of leakage and is displayed by EvitaXL as the leakage minute volume MV_{leak} .

EvitaXL can compensate for this leakage in volume-controlled ventilation.

Example:

Tidal volume setting $V_T = 500$ mL, 10 % leakage in tube.

Leakage compensation Off

EvitaXL delivers 500 mL. This value is indicated as V_{Ti} . 50 mL escape as leakage during inspiration, and 450 mL reach the lung. 450 mL are expired, and 45 mL again escape as leakage. A tidal volume of 405 mL is measured on the expiration side and indicated as V_{Te} .

With a ventilation rate of 10 strokes per minute, a minute volume of 5.0 L/min is delivered on the inspiration side and a minute volume of 4.05 L/min is measured on the expiration side. The lung is ventilated with an MV of 4.5 L/min.

Without leakage compensation, the set V_T determines the volume delivered by EvitaXL.

Leakage compensation On

With automatic leakage compensation, EvitaXL delivers 550 mL tidal volume on the basis of the measured leakage minute volume, instead of the 500 mL set. 500 mL reach the lung and the inspiratory tidal volume is 500 mL. This value is indicated as V_T .

The volume of 450 mL measured on the expiration side is displayed without compensation, even when leakage compensation is activated. The minute volume measured on the expiration side is 4.5 L/min and is also uncompensated.

If this were not so, the alarm for a low minute volume could be inhibited by the expiratory leakage compensation. EvitaXL must always emit an alarm if the minute volume is too low.

With leakage compensation, the set V_T determines the volume to be delivered to the patient.

This example has been simplified:

In fact, the calculated leakage correction takes into account the pressures in the hose system. A higher percentage volume is lost on the inspiration side than on the expiration side because the pressure during inspiration is higher.

The displayed leakage minute volume MV_{leak} is based on the mean pressure P_{mean} .

The leakage minute volume MV_{leak} also takes the inspiratory leaks into account. The sum of the minute volume MV + the leakage minute volume MV_{leak} is consequently greater than the inspiratory minute volume delivered to the patient.

Unlimited volume compensation is inappropriate. EvitaXL compensates for losses of up to 100 % of the set tidal volume VT.

Due to technical tolerances, a small leakage minute volume may be displayed even if the hose system is leakproof.

Leakage compensation in application mode »Mask« (NIV)

Depending on the set patient mode, EvitaXL compensates leakages up to the following values in order to detect a patient trigger:

Adult mode: 30 L/min

Paediatric mode: 15 L/min

Calculated leakages are compensated by EvitaXL up to 200 % of the set tidal volume, but not more than max. 2 L (regardless of the patient mode).

Tube compensation ATC

The special function »**Tube compensation**« regulates the airway pressure to the tracheal level. This function calculates and displays the tracheal pressure on the basis of a mathematical tube model, the set tube type and the inside diameter of the tube.

The selected tube type and the inside diameter of the tube must correspond with the real tube for correct calculation of the tracheal pressure. EvitaXL calculates the tracheal pressure on the basis of a square function of tube resistance and patient flow:

$$P_{\text{Trachea}} = PAW - K_{\text{Tube}} \times \text{Flow}^2$$

P_{Trachea}: Pressure in the trachea

PAW: Pressure at the Y-piece of the hose system

K_{Tube}: Tube coefficient (see table)

Flow: Patient flow
(inspiration: flow >0; expiration: flow <0)

When automatic tube compensation is active, EvitaXL controls the ventilation pressure during spontaneous breathing and during pressure-controlled mechanical breathing cycles so that the resistive breathing effort on the tube is compensated in accordance with the selected degree of compensation.

Compensation can be deactivated for the expiratory breathing cycle.

Depending on the direction of the patient flow, the airway pressure is increased during inspiration or decreased during expiration. The airway pressure can be increased to not more than 5 mbar below the set upper alarm limit PAW_{AL} and reduced to not less than 0 mbar.

The maximum airway pressure is limited to PAW_{AL} - 5 mbar. The advisory message "Pressure limited !" is displayed.

Pressure support is calculated on the basis of a square function of tube resistance and patient flow:

$$\Delta PAW = \text{Comp.} * K_{\text{Tube}} * \text{Flow}^2$$

ΔPAW : Pressure support on the tube

Comp.: Degree of compensation 0 to 100 %

K_{Tube} : Tube coefficient (see table)

Flow: Patient flow

The tube coefficient K_{Tube} is largely determined on the basis of the results obtained by Guttman et al. Guttman, Wolf et al, see literature reference [19] on page 235.

The tube coefficient K_{Tube} for the full-length tube is always taken as the basis. The effect of the shortened length is negligible.

Tube type	Inside diameter of tube (mm)	Tube coefficient K_{Tube} (mbar/L ² /s ²)
Endotracheal tube	2.50.....	480.00
	3.00.....	250.00
	3.50.....	140.00
	4.00.....	80.00
	4.50.....	50.00
	5.00.....	34.40
	5.50.....	23.70
	6.00.....	17.21
	6.50.....	13.05
	7.00.....	10.56
	7.50.....	8.41
	8.00.....	6.57
	8.50.....	5.17
	9.00.....	4.29
	9.50.....	3.80
	10.00.....	3.50
10.50.....	3.00	
11.00.....	2.50	
11.50.....	2.00	
12.00.....	1.50	

Tube type	Inside diameter of tube (mm)	Tube coefficient K_{Tube} (mbar/L ² /s ²)
Tracheotomy tube	2.50.....	480.00
	3.00.....	250.00
	3.50.....	140.00
	4.00.....	80.00
	4.50.....	50.00
	5.00.....	30.96
	5.50.....	15.40
	6.00.....	10.00
	6.50.....	7.90
	7.00.....	6.38
	7.50.....	5.20
	8.00.....	4.50
	8.50.....	3.70
	9.00.....	2.95
	9.50.....	2.65
	10.00.....	2.50
10.50.....	2.05	
11.00.....	1.65	
11.50.....	1.35	
12.00.....	1.10	

Weaning parameters

P 0.1, RSB, NIF:

A number of criteria must be taken into account by the doctor when deciding whether or not a patient is ready to be weaned off the ventilator. In addition to the results of examinations and laboratory analyses, ventilation parameters can also be used to judge whether the patient can be weaned successfully.

The following weaning parameters are measured/calculated by EvitaXL:

- Occlusion pressure P 0.1
- Rapid Shallow Breathing RSB
- Negative Inspiratory Force NIF

Occlusion pressure P 0.1

Breathing drive can be measured at the start of inspiration by measuring the mouth pressure during a short-term occlusion: within 100 ms, the pressure is not influenced by physiological compensation reaction (e.g. reflected breathing stop or increased breathing drive). This pressure is always dependent on the muscle strength of the diaphragm. Therefore, the negative mouth pressure P 0.1 after 0.1 seconds is a direct measure of neuro-muscular breathing drive*.

EvitaXL displays the value for the measured pressure difference without a negative sign.

For patients with healthy lungs and regular breathing, P 0.1 will be about 3 to 4 mbar. A higher P 0.1 signifies a high breathing drive which can only be maintained for a limited period.

P 0.1 values above 6 mbar, e.g. for a COPD** patient, indicate impending exhaustion (RMF – respiratory muscle fatigue).

EvitaXL keeps the inspiratory valve closed after an expiration and measures the airway pressure produced by the inspiratory effort during 100 ms.

The 100 ms time interval starts when a negative pressure of -0.5 mbar below PEEP/CPAP is measured as a result of the inspiratory effort.

The second pressure value is determined after 100 ms. The inspiratory valve is opened simultaneously; the patient can breathe normally again.

The occlusion pressure P 0.1 is the difference between the pressure values P2 – P1.

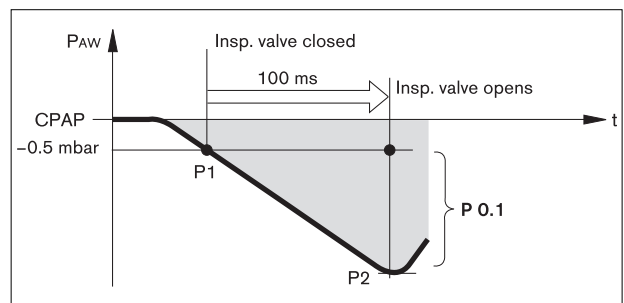

* Bibliography [10], [15], page 235

** COPD = Chronic Obstructive Pulmonary Disease

Rapid-Shallow-Breathing RSB

The Rapid Shallow Breathing index (RSB) is the quotient of the spontaneous breathing frequency (spontaneously breathed breaths per minute) and the tidal volume:

$$\text{RSB [1/(min x L)]} = \frac{\text{fspn [1/min]}}{V_T \text{ [L]}}$$

The lower the RSB index for a patient with spontaneous breathing, the more probably he or she can be weaned successfully. The significance of the RSB index is due to the fact that patients who can be weaned successfully tend to have a lower spontaneous breathing frequency and a higher tidal volume than those who are not yet ready to be weaned.

In their 1991 study* Yang and Tobin showed that the RSB index is an effective instrument for predicting the success of an attempt to wean the patient. Patients with an RSB index of <100 1/(min x L) were weaned with a probability of 80 %, while 95 % of those with an RSB index of >100 1/(min x L) were not yet ready to be weaned. EvitaXL indicates the RSB index in CPAP/ASB and PPS modes.

Negative Inspiratory Force NIF

The Negative Inspiratory Force Index (NIF)** measures the patient's maximum inhalation effort after exhaling. The patient system is closed during measurement of the NIF. This value is also known as the Maximum Inspiratory Pressure (MIP). As a result of the inhalation effort during manually extended expiration, the patient generates a negative pressure in relation to PEEP. The probability that the patient can be weaned successfully increases with the magnitude of this negative pressure. Patients with a NIF of <-30 mbar can in all probability be extubated successfully, while those with a NIF of up to -20 mbar will most probably prove unsuccessful. EvitaXL determines the NIF value during manually extended expiration. The patient system closes following expiration by the patient while the »Exp. Hold« key is held down and EvitaXL measures the maximum inhalation effort made by the patient. The NIF is measured as a pressure against PEEP. The measuring procedure is ended when the »Exp. Hold« key is released or after not more than 15 seconds. The last measured NIF value and the time of measurement are shown in Table 2 on the screen.

* Bibliography [16], page 235

** Bibliography [17], [18], page 235

Intrinsic PEEP – PEEPi

Intrinsic PEEP is measured in two phases: EvitaXL keeps the inspiration and expiration valves closed during measuring phase 1, so that it is impossible for gas to flow into the ventilation system from inspiration and to escape from it. During this closed phase, pressure is equalized between the lungs and the ventilation system. EvitaXL measures the pressure curve. Measuring phase 1 is ended:

- when there is no further change in the pressure curve but at the earliest after 0.5 seconds,
- at the latest after 3 seconds in adult mode or after 1.5 seconds in paediatric mode.

The start value corresponds to PEEP, and the value at the end of the closed phase is the Intrinsic PEEP.

At the end of measuring phase 1, EvitaXL opens the expiration valve and measures the expiratory flow generated by intrinsic PEEP during measuring phase 2. During this period, the lung is depressurised to PEEP. Measuring phase 2 is ended:

- when the expiration flow has returned to 0 but at the earliest after 0.5 seconds.
- at the latest after 7 seconds in adult mode or after 3.5 seconds in paediatric mode.

The integrated flow corresponds to the air volume trapped in the lungs V_{trap} by Intrinsic PEEP.

Measuring times of measuring phase 1 for Intrinsic PEEP:

- For adult ventilation max. 3 seconds
- For paediatric ventilation max. 1.5 seconds

Measuring times of measuring phase 2 for V_{trap} :

- For adult ventilation max. 7 seconds
- For paediatric ventilation max. 3.5 seconds

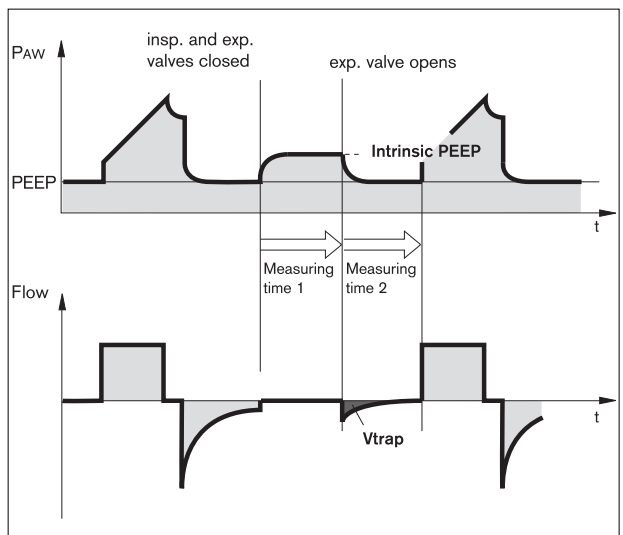

Low Flow PV-Loop

The Low Flow PV-Loop* measuring procedure records a static pressure-volume curve, which can be used to assess the mechanical properties of the lung.

By slowly filling the lung with a small, constant flow, only the elastistic properties are determined in the PV-Loop. This almost static process shows a good correlation with the static Super-Syringe or Occlusion Method [27 to 29]**, as long as the flow is small [22 to 26]**.

There are various approaches for optimising ventilation settings based on measurements of the lung mechanics. All approaches aim at avoiding a recurrent collapsing and re-opening of alveoli and a possible over-inflation of the lung. A suggestion is made to set the positive end-expiratory pressure (PEEP) on the basis of the lower inflection point (LIP) and to limit the tidal volume or plateau pressure on the basis of the upper inflection point (UIP) [30 to 33]**. Other research recommends taking into account the expiratory limb of the PV-Loop when determining the positive end-expiratory pressure (PEEP) required to maintain an alveolar recruitment. Characteristic points on the expiratory limb are described in this context as the critical closure pressure (CCP) or the point of maximum curvature (PMC) [22, 24, 27, 30, 34 to 40]**.

To determine these points on the inspiratory/expiratory limb, two cursors can be moved over the PV-Loop. In addition, the static compliance (C_{stat}) can also be calculated.

Performing a low flow procedure may decrease the patient's systemic circulatory pressure and could cause a pneumothorax, for example. The condition of the patient must therefore be taken into account when making the settings.

The applied pressures and volumes must be suitable for the patient. Potentially high intrathoracic pressures can be applied over a comparatively long period whilst performing the procedure. The patient must therefore be considered to be haemodynamically stable before starting the procedure and the vital data must be closely monitored and documented during the entire measurement. A significantly higher venous return, caused by an abrupt relieving of the intrathoracic pressure, can overstrain the heart under certain conditions. This is why the procedure is usually terminated, even after only an inspiratory application, with a pressure ramp of 5 mbar/s.

The procedure is similar to an apnoea with a single slow breath. An acceptable procedure duration should also be estimated for the patient. To avoid longer times with a reduced gas exchange, the procedure can only be restarted after 60 seconds after nebulisation, suction or a previous Low Flow PV-Loop.

Spontaneous breathing or leaks during the procedure distort the measured values and should be ruled out before the application.

Dependent on the duration of the procedure and the metabolic turnover of the patient, the expiratory limb of a PV-Loop, in particular, can be easily influenced by the O_2 consumption, which is not offset by a corresponding CO_2 production [41, 42]**.

* Lung Protection Package option

** Bibliography, see page 235

Insp. O₂ concentration during medicament nebulisation

Use only medicament nebuliser 84 12 935 (white central section).

If other medicament nebulisers are used, considerable deviations may occur in the tidal volume and the inspiratory O₂ concentration!

To minimise the deviation from the set O₂ concentration, EvitaXL uses a mixed gas to drive the medicament nebuliser.

In adult ventilation, this mixed gas is generated by switching over between compressed gases (medical air and oxygen) in synchronisation with inspiration.

In paediatric ventilation, the nebuliser is operated continuously, with medical air or oxygen in alternation. The drive gas of the medicament nebuliser therefore roughly corresponds to the set FiO₂.

The graph shows the possible deviations of the applied O₂ concentration as a function of the set FiO₂ with a minimal inspiratory flow (15 L/min) in adult ventilation or at ventilation frequencies above 12 bpm in paediatric ventilation.

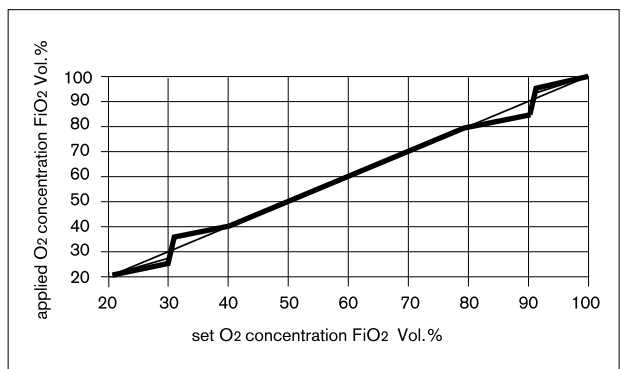

Screen configurations

The table lists the settings with which the six memory locations are pre-assigned at the works. Measured values and curves which are assigned to a certain option (e. g. CO₂) are only available when the option is released.

To store customised screen configurations, see page 132.

	Screen configuration					
	1 Standard	2 Mandatory ventilation or recruitment	3 SmartCare	4 Spontaneous breathing	5 APRV	6 NIV
Curve display						
Curve	PAW Flow Volume	PAW Flow Volume	PAW Flow Volume	PAW Flow Volume	PAW Flow Volume	PAW Flow Volume
Curve and short trend	PAW-MV Flow-V _{Te} Volume-f	PAW-C Flow-R Volume- \dot{V} CO ₂	PAW-f Flow-Volume Volume-RSB	PAW-RSB Flow-P 0.1 Volume- \dot{V} CO ₂	PAW-C Flow-R Volume- \dot{V} CO ₂	PAW-MV Flow-V _{Te} Volume-f
Curve and RecrTrend	- - -	PAW-EIP/ PEEP Flow-V _{Te} Volume-C	- - -	- - -	- - -	- - -
Loops left / right	PAW-V / V-Flow Flow-PAW / PAW-V PAW-V / V-Flow	PAW-V / PTrach-V Flow-PAW / Flow-PTrach V-Flow / V-CO ₂	PAW-V / PTrach-V Flow-PAW / Flow-PTrach V-Flow / V-CO ₂	PAW-V / PTrach-V Flow-PAW / Flow-PTrach V-Flow / V-CO ₂	PAW-V / PTrach-V Flow-PAW / Flow-PTrach V-Flow / V-CO ₂	PAW-V / PTrach-V Flow-PAW / Flow-PTrach V-Flow / V-CO ₂
Trend	MV V _{Te} f	MV V _{Te} \dot{V} CO ₂	fspn MV Diagnosis	MV V _{Te} \dot{V} CO ₂	MV V _{Te} \dot{V} CO ₂	MV V _{Te} f
Trend selection	MV V _{Te} f \dot{V} CO ₂ R C P 0.1 RSB - -	MV V _{Te} f \dot{V} CO ₂ R C P 0.1 RSB - -	MV V _{Te} f \dot{V} CO ₂ R C P 0.1 RSB SC-Trend SC-Trend	MV V _{Te} f \dot{V} CO ₂ R C P 0.1 RSB - -	MV V _{Te} f \dot{V} CO ₂ R C P 0.1 RSB - -	MV V _{Te} f \dot{V} CO ₂ R C P 0.1 RSB - -

	Screen configuration					
	1 Standard	2 Mandatory ventilation or recruitment	3 SmartCare	4 Spontaneous breathing	5 APRV	6 NIV
Function keys	- - - - - -	O ₂ suction PEEP _i Low Flow PV-Loop Nebuliser Values Logbook Day/Night	O ₂ suction Diagnosis SC overview SC data SC logbook SC trends Day/Night	O ₂ suction P 0.1 NIF Nebuliser Values Logbook Day/Night	O ₂ suction Nebuliser Values Logbook Day/Night - -	O ₂ suction NeoFlow Sensor Nebuliser Values Logbook Diagnosis Fct. Day/Night
Measured values						
■ ■ ■ Set 1	P _{mean} -PEEP FiO ₂ MV MV _{spn} f _{total} VT	FiO ₂ P _{peak} -P _{mean} VT-V _{Te} f _{total} -f _{spn} MV-MV _{spn} R-C	FiO ₂ f _{spn} VT-etCO ₂ SC f _{spn} SC-VT SC-etCO ₂	FiO ₂ P _{peak} -P _{mean} VT _i -VT _e f _{total} -f _{spn} MV-MV _{spn} R-C	FiO ₂ P _{peak} -P _{mean} VT-V _{Te} f _{total} -f _{spn} MV-MV _{spn} R-C	FiO ₂ VT _i VT _e MV MV _{spn} VTASB
■ ■ ■ Set 2	P _{mean} -PEEP P _{peak} f _{mand} -f _{spn} f _{total} VTASB VT	P _{mean} P _{peak} P _{min} P _{Plat} PEEP MV	Diagnosis Phase Duration SC f _{spn} SC-VT SC-etCO ₂	P _{mean} P _{peak} P _{min} P _{Plat} PEEP MV	P _{mean} P _{peak} P _{min} P _{Plat} PEEP MV	P _{mean} P _{peak} P _{min} P _{Plat} PEEP MV
■ ■ ■ Set 3	P _{mean} -PEEP - etCO ₂ V̇CO ₂ R C	V̇CO ₂ V _{ds} /V _{Te} etCO ₂ V _{Te} P _{mean} MV	f _{spn} -MV etCO ₂ -V _{ds} /V _{Te} PEEP-P _{peak} R C -	V̇CO ₂ V _{ds} /V _{Te} etCO ₂ VTASB NIF RSB	V̇CO ₂ V _{ds} /V _{Te} etCO ₂ - - -	RSB R C - - -
Customised settings	Mode Mode ext. Flow Thigh Tlow O ₂ VT f T _{insp} P _{max} PEEP PASB P _{insp} Phigh Plow	Mode Mode ext. Patient VT f P _{max} FiO ₂ Flow T _{insp} I : E P _{insp} PEEP ATC state Tube ID Ramp	Mode Mode ext. Patient ATC state Tube ID O ₂ PASB PEEP Ramp - - - -	Mode Mode ext. VT f P _{max} FiO ₂ Flow T _{insp} I : E P _{insp} PEEP ATC state Tube ID Vol.Assist FlowAssist	Mode Mode ext. f P _{max} FiO ₂ Tlow Phigh Plow PEEP ATC state Tube ID - - -	Mode Mode ext. Patient VT f FiO ₂ Flow T _{insp} I : E P _{insp} P _{max} PASB Ramp PEEP -

	Screen configuration					
	1 Standard	2 Mandatory ventilation or recruitment	3 SmartCare	4 Spontaneous breathing	5 APRV	6 NIV
Customised values	MV	FiO ₂	MV	FiO ₂	FiO ₂	FiO ₂
	MV _{spn}	P _{peak}	MV _{spn}	P _{peak}	P _{peak}	P _{peak}
	P _{peak}	P _{Plat}	V _T	P _{Plat}	P _{Plat}	P _{Plat}
	P _{Plat}	P _{mean}	V _{Te}	P _{mean}	P _{mean}	P _{mean}
	P _{mean}	P _{min}	R	P _{min}	P _{min}	P _{min}
	PEEP	PEEP	C	PEEP	PEEP	PEEP
	f _{total}	MV	f _{total}	MV	MV	MV
	f _{spn}	MV _{spn}	f _{spn}	MV _{spn}	MV _{spn}	MV _{spn}
	-	V _T	etCO ₂	V _T	V _{Te}	V _T
	f _{spn}	V _{Te}	V _{ds}	V _{Te}	etCO ₂	V _{Te}
	-	etCO ₂	V _{ds} /V _{Te}	etCO ₂	\dot{V} CO ₂	R
	-	\dot{V} CO ₂	\dot{V} CO ₂	\dot{V} CO ₂	R	C
	V _{Te}	R	FiO ₂	R	C	f _{total}
	VTASB	C	PEEP	C	f _{total}	f _{mand}
	-	f _{total}	P _{peak}	f _{total}	f _{mand}	f _{spn}
	-	f _{mand}	P _{mean}	f _{mand}	f _{spn}	RSB
	R	f _{spn}	NIF	f _{spn}	-	-
	C	RSB	P 0.1	RSB	-	-

Abbreviations

Abreviation	Explanation	Abreviation	Explanation
Alarm Info	Display additional causes of alarms	f _{Apnoea}	Frequency setting for apnoea ventilation
Alarm Reset	Acknowledge alarm message	FeCO ₂	Expiratory CO ₂ concentration
APRV	Airway Pressure Release Ventilation Spontaneous breathing at continuous positive airway pressure with short-term pressure release	FiO ₂	Inspiratory O ₂ concentration
ASB	Assisted Spontaneous Breathing Pressure supported spontaneous breathing	Flow	Setting for the maximum inspiratory flow
ATC	Automatic Tube Compensation	Flowtrig	Setting for the flow trigger threshold
AutoFlow	Special function for automatic regulation of the inspiratory flow	f _{mand}	Mechanical portion of frequency
BIPAP	Biphasic Positive Airway Pressure Spontaneous breathing at continuous positive airway pressure with two different pressure levels	f _{spn}	Spontaneous breathing portion of frequency
BIPAP _{Assist}	Biphasic Positive Airway Pressure Assisted Assisted ventilation with continuous positive airway pressure with two different pressure levels	I : E	Ratio of inspiration time: expiration time
bpm	breath per minute	IBW	Ideal body weight
BTPS	Body Temperature, Pressure, Saturated Measured values based on the condition of the patient's lungs, with body temperature 37 °C, steam-saturated gas, atmospheric pressure	ID Ø	Internal tube diameter (set value)
C	Compliance	ILV	Independent Lung Ventilation Ventilation with 2 ventilators, 1 for each lung
CAN	Controller Area Network	Insp. Flow	Inspiratory flow
CCP	Critical Closing Pressure	IPPV	Intermittent Positive Pressure Ventilation Intermittent ventilation with positive pressure
Comp.	Degree of tube compensation (setting)	IPPV _{Assist}	Assisted Intermittent Positive Pressure Ventilation
CPAP	Continuous Positive Airway Pressure Breathing with continuous positive pressure in the airways	IRV	Inversed Ratio Ventilation Ventilation with inversed inspiration/expiration ratio
CPAP-ASB	Pressure-supported breathing with continuous positive airway pressure	ISO 5369	International standard for medical ventilators, lung ventilation
CPPV	Continuous Positive Pressure Ventilation Controlled ventilation with continuous positive airway pressure	KG	Body weight [kg]
C _{stat}	static compliance	K _{Tube}	Tube coefficient
ΔPASB	Setting for PASB relative to PEEP	LIP	Lower Inflection Point
EIP	End-inspiratory pressure	LUST	List-controlled universal interface driver program
EMC	Electromagnetic compatibility	MEDIBUS	Dräger communication protocol for medical devices
etCO ₂	End-expiratory CO ₂ concentration	MMV	Mandatory Minute Volume Ventilation Mandatory minute volume ventilation
Ext. Flow	External Flow	MV	Minute Volume
f	Frequency in bpm	MV _{leak}	Leakage minute volume
Fail to cycle	Machine detects no inspiration	MV _{spn}	Spontaneous breathing portion of minute volume
		NeoFlow	Option for neonatal ventilation
		NIF	Negative Inspiratory Force Maximum inhalation effort
		NIV	Non-invasive ventilation
		NTC	Negative temperature coefficient
		O ₂	Set value for inspiratory O ₂ concentration [Vol.]
		O ₂ ↑ suction	Oxygen enrichment program active

Abreviation	Explanation	Abreviation	Explanation
P 0.1	100 ms occlusion pressure	UMDNS	Universal Medical Device Nomenclature System
PASB	Set value of ASB pressure support		Nomenclature for medical devices
PAW	Airway pressure	$\dot{V} \text{ CO}_2$	CO ₂ production [L/min]
PEEP	Positive End-Expiratory Pressure	Vds	Serial dead space
PEEPi	Intermittent positive end-expiratory pressure = exp. Sigh	VLimit	
P _{high}	Set value of the upper pressure level APRV	VT	Setting for tidal volume
P _{insp}	Set value of the upper pressure level in BIPAP	VT _{Apnoea}	Setting for tidal volume of apnoea ventilation
Pleth	Plethysmogram	VTASB	Inspiratory tidal volume during an ASB stroke
PLimit		V _{Te}	Exp. tidal volume
P _{low}	Set value of the lower pressure level in APRV	V _{Ti}	Insp. tidal volume
PLV	Pressure Limited Ventilation	V _{trap}	Proportion trapped in the lung through the intrinsic PEEP and not exhaled during the subsequent expiration
P _{max}	Setting for pressure limited ventilation		
PMC	Point of Maximum Curvature		
P _{mean}	Mean airway pressure		
P _{min}	Minimum airway pressure		
P _{peak}	Peak pressure		
P _{plat}	End-inspiratory airway pressure		
PPS	Proportional Pressure Support Spontaneous breathing with variable pressure support proportional to the patient flow and tidal volume		
PS	Pressure Support		
QRS	Intraventricular excitation propagation in the ECG		
R	Resistance		
RecrTrend	Recruitment Trend Breath-based trend		
RSB	Rapid Shallow Breathing Quotient of spontaneous breathing frequency and tidal volume		
SB	Spontaneous Breathing Spontaneous breathing at ambient pressure		
SIMV	Synchronized Intermittent Mandatory Ventilation		
SpO ₂	Functional oxygen saturation		
T	Inspiratory breathing gas temperature		
T _{Apnoea}	Apnoea alarm time		
T _e	expiration time		
TGI	Tracheale Gas Insufflation		
T _{high}	Time for the upper pressure level in APRV		
T _{insp}	Set value of the inspiratory time		
T _{low}	Time for the lower pressure level in APRV		
UIP	Upper Inflection Point		

Symbols

Symbols	Explanation
Alarm Silence	Suppress acoustic alarm for 2 minutes
Alarm Limits	Set alarm limits
Ventilator Settings	Settings for ventilation
Sensor Parameter	Sensor calibration
System Setup	Configuration
Start/Standby	Standby/ventilation
Main screen	Back to main screen
1 2 3	Select different sets of measured values
Freeze	Freeze screen
Display alarm limit in trend	Display alarm limit in trend
Nebul.	Medicament nebuliser active
Real-time curves, loops and trends	Real-time curves, loops and trends
Humidifier	Humidifier
HME heat and moisture exchanger	HME heat and moisture exchanger
AC mains plug connector	AC mains plug connector
ext.	External battery
int.	Integrated battery
Lower alarm limit	Lower alarm limit
Upper alarm limit	Upper alarm limit
Fit flow sensor	Fit flow sensor
Ramp	Pressure rise time for ASB
Direct access to settings unlocked/locked	Direct access to settings unlocked/locked
Exp. Expiration port (GAS RETURN)	Exp. Expiration port (GAS RETURN)
Insp. Inspiration port (GAS OUTPUT)*	Insp. Inspiration port (GAS OUTPUT)*
Gas output (EXHAUST – NOT FOR SPIROMETERS)*	Gas output (EXHAUST – NOT FOR SPIROMETERS)*
Adult	Adult mode
Paed.	Paediatric mode
Neo.	Neonatal mode
? ▲	Supplementary information
x	Quit menu
Note Instructions for Use!	Note Instructions for Use!

* additionally required, depending on configuration

Symbols	Explanation
Earth	Earth
Protection class type B	Protection class type B
Protection class type BF	Protection class type BF
Spontaneous breathing activity by the patient	Spontaneous breathing activity by the patient
Evita Remote remote-control unit	Evita Remote remote-control unit
Nurse call	Nurse call
Tube compensation activated	Tube compensation activated
Select screen configuration	Select screen configuration
Save screen configuration	Save screen configuration
Masking out the screen configuration	Masking out the screen configuration

Bibliography

- [1] Baum, M., Benzer, H., Mutz, N., Pauser, G., Tonczar, L.:
Inversed Ratio Ventilation (IRV)
Die Rolle des Atemzeitverhältnisses in der Beatmung
beim ARDS
Anaesthesist 29 (1980), 592-596
- [2] Geyer, A., Goldschmied, W., Koller, W., Winter, G.:
Störung der Gerätefunktion bei Anbringung eines Bak-
terienfilters in den Expirationsschenkeln des Beat-
mungssystems
Anaesthesist 34 (1985), 129-133
- [3] Baum, M., Benzer, H., Putensen, Ch., Koller, W., Putz, G.:
Biphasic Positive Airway Pressure (BIPAP) – eine neue
Form der augmentierenden Beatmung
Anaesthesist 38 (1989), 452-458
- [4] Luger, Th.J., Putensen, Ch., Baum, M., Schreithofer, D.,
Morawetz, R.F., Schlager, A.:
Entwöhnung eines Asthmatikers mit Biphasic Positive
Airway Pressure (BIPAP) unter kontinuierlicher Sufentanil
Gabe
Anaesthesist (1990) 39: 557-560
- [5] Hensel, I.:
Atemnotsyndrom nach Beinahe-Ertrinken
Rettung durch neuartiges Beatmungsprogramm?
Rettungsdienst 11 (Nov. 1991), 737-739
- [6] Meyer, J.:
Neue Beatmungsformen
Anästhesiol. Intensivmed. Notfallmed. Schmerzther.
26 (1991) 337 - 342
- [7] Vincent, J.-L.:
Yearbook of Intensive care and Emergency Medicine
Springer-Verlag 1993
- [8] Stock MC, Downs JB, Frolicher D (1987):
Airway pressure release ventilation.
Critical Care Medicine 15:462 -466
- [9] Räsänen J, Cane R, Downs J, et al. (1991):
Airway pressure release ventilation during acute lung
injury: A prospective multicenter trial.
Critical Care Medicine 19:1234 - 1241
- [10] Sassoon CSH, TeTT, Mahutte CK, Light RW:
Airway occlusion pressure. An important indicator for
succesful weaning in patients with chronic obstructive
pulmonary disease.
Am Rev Respir Dis 1987; 135:107-113
- [11] E. Voigt:
BIPAP Anwendungshinweise und Kasuistik.
Dräger-Mitteilungen "Medizintechnik aktuell" 1/94
- [12] E. Bahns:
BIPAP – Zwei Schritte nach vorn in der Beatmung
Dräger Fibel zur Evita Beatmung
- [13] H. Burchardi, J. Rathgeber, M. Sydow:
The Concept of Analgo-Sedation depends on the Con-
cept of Mechanical Ventilation
Yearbook of Intensive Care and Emergency Medicine,
1995, Springer Verlag
- [14] M. Sydow, H. Burchardi, E. Ephraim, S. Zeilmann,
T. Crozier:
Long-term Effects of Two Different Ventilatory Modes on
Oxygenation in Acute Lung Injury
American Journal of Respiratory and Critical Care Medi-
cine, Vol 149, 1994
- [15] R. Kuhlen, S. Hausmann, D. Pappert, K. Slama,
R. Rossaint, K. Falke:
A new method for P0.1 measurement using standard res-
piratory equipment
Intensive Care Med (1995) 21
- [16] Yang, K.L.; Tobin, M.J.:
A Prospective Study of Indexes Prediction the Outcome
Of Trials of Weaning from Mechanical Ventilation
The New England Journal of Medicine, 1991, 324, S.
1445-1450
- [17] Tobin, Jubran, A.:
Advances in Respirators Monitoring During Mechanical
Ventilation
CHEST 1999, 116, S. 1416-1425
- [18] Tobin, M.J., Charles, G.A.:
Discontinuation of Mechanical Ventilation in: Tobin, M.J.
Principles and Practice of Mechanical Ventilation, 1994,
S. 1177-1206
- [19] Guttman, Wolf et al:
Continuous Calculation of Tracheal Pressure in Trache-
ally Intubated Patients, Anesthesiology, Vol.79, Sept.
1993. 1993.
- [20] Younes, M.:
Proportional Assist Ventilation, Principles and Practice of
Mechanical Ventilation, Tobin, M.J. (Hrsg.), McGraw-Hill,
1994.
- [21] Guttman, Wolf et al:
Continuous Calculation of Tracheal Pressure in Trache-
ally Intubated Patients, Anesthesiology, Vol.79, Sept.
1993. 1993.
- [22] Gama AM, Meyer EC, Gaudencio AM, Grunauer MA,
Amato MB, de Carvalho CR, Barbas CS:
Different low constant flows can equally determine the
lower inflection point in acute respiratory distress syn-
drome patients
Artif Organs. 2001 Nov; 25(11): 882-9.

- [23] Blanc Q, Sab JM, Philit F, Langevin B, Thouret JM, Noel P, Robert D, Guerin C:
Inspiratory pressure-volume curves obtained using automated low constant flow inflation and automated occlusion methods in ARDS patients with a new device. *Intensive Care Med.* 2002 Jul; 28(7): 990-4. Epub 2002 Jun 12.
- [24] Albaiceta GM, Piacentini E, Villagra A, Lopez-Aguilar J, Taboada F, Blanch L:
Application of continuous positive airway pressure to trace static pressure-volume curves of the respiratory system. *Crit Care Med.* 2003 Oct; 31(10): 2514-9
- [25] Bensenor FE, Vieira JE, Auler JO Jr:
Guidelines for inspiratory flow setting when measuring the pressure-volume relationship. *Anesth Analg.* 2003 Jul; 97(1): 145-50, table of contents.
- [26] Rouby J-J.; Vieira S:
Pressure/volume curves and lung computed tomography in acute respiratory distress syndrome *European Respiratory Journal*, 1 August 2003, vol. 22, no. Supplement 42, pp. 27-36(10)
- [27] Mehta S, Stewart TE, MacDonald R, Hallett D, Banayan D, Lapinsky S, Slutsky A:
Temporal change, reproducibility, and interobserver variability in pressure-volume curves in adults with acute lung injury and acute respiratory distress syndrome. *Crit Care Med.* 2003 Aug; 31(8): 2118-25.
- [28] Servillo G, De Robertis E, Maggiore S, Lemaire F, Brochard L, Tufano R:
The upper inflection point of the pressure-volume curve. Influence of methodology and of different modes of ventilation *Intensive Care Med.* 2002 Jul; 28(7): 842-9. Epub 2002 May 31.
- [29] Servillo G, Svantesson C, Beydon L, Roupie E, Brochard L, Lemaire F, Jonson B:
Pressure-volume curves in acute respiratory failure: automated low flow inflation versus occlusion. *Am J Respir Crit Care Med.* 1997 May; 155(5):1629-36.
- [30] Takeuchi M, Goddon S, Dolhnikoff M, Shimaoka M, Hess D, Amato MB, Kacmarek RM:
Set positive end-expiratory pressure during protective ventilation affects lung injury. *Anesthesiology.* 2002 Sep; 97(3): 682-92.
- [31] Matamis D, Lemaire F, Harf A, Brun-Buisson C, Ansquer JC, Atlan G:
Total respiratory pressure-volume curves in the adult respiratory distress syndrome. *Chest.* 1984 Jul; 86(1): 58-66.
- [32] Suter PM, Fairley B, Isenberg MD:
Optimum end-expiratory airway pressure in patients with acute pulmonary failure. *N Engl J Med.* 1975 Feb 6; 292(6): 284-9.
- [33] Amato MB, Barbas CS, Medeiros DM, Schettino Gde P, Lorenzi Filho G, Kairalla RA, Deheinzelin D, Morais C, Fernandes Ede O, Takagaki TY, et al:
Beneficial effects of the "open lung approach" with low distending pressures in acute respiratory distress syndrome. A prospective randomized study on mechanical ventilation. *Am J Respir Crit Care Med.* 1995 Dec; 152(6 Pt 1): 1835-46.
- [34] Arnold JH:
To recruit or not derecruit: that is the question. *Crit Care Med.* 2002 Aug; 30(8): 1925-7.
- [35] Harris RS, Hess DR, Venegas JG:
An objective analysis of the pressure-volume curve in the acute respiratory distress syndrome. *Am J Respir Crit Care Med.* 2000 Feb; 161(2 Pt 1): 432-9.
- [36] Hickling KG:
The pressure-volume curve is greatly modified by recruitment. A mathematical model of ARDS lungs. *Am J Respir Crit Care Med.* 1998 Jul; 158(1):194-202.
- [37] Kallet RH:
Pressure-volume curves in the management of acute respiratory distress syndrome. *Respir Care Clin N Am.* 2003 Sep; 9(3): 321-41.
- [38] Pelosi P, Gattinoni L:
Respiratory mechanics in ARDS: a siren for physicians? *Intensive Care Med.* 2000 Jun; 26(6): 653-6.
- [39] Rimensberger PC, Cox PN, Frndova H, Bryan AC:
The open lung during small tidal volume ventilation: concepts of recruitment and "optimal" positive end-expiratory pressure. *Crit Care Med.* 1999 Sep; 27(9): 1946-52
- [40] Rimensberger PC, Pristine G, Mullen BM, Cox PN, Slutsky AS:
Lung recruitment during small tidal volume ventilation allows minimal positive end-expiratory pressure without augmenting lung injury. *Crit Care Med.* 1999 Sep; 27(9): 1940-5.
- [41] Dall'ava-Santucci J, Armaganidis A, Brunet F, Dhainaut JF, Chelucci GL, Monsallier JF, Lockhart A:
Causes of error of respiratory pressure-volume curves in paralyzed subjects. *J Appl Physiol.* 1988 Jan; 64(1): 42-9.
- [42] Gattinoni L, Mascheroni D, Basilico E, Foti G, Pesenti A, Avalli L:
Volume/pressure curve of total respiratory system in paralyzed patients: artefacts and correction factors. *Intensive Care Med.* 1987; 13(1):19-25.

Special ASCII characters used

Characters	Explanation	Hexadecimal code	Control characters
NUL	Null	00	^@
SOH	Start of Heading	01	^A
STX	Start of Text	02	^B
ETX	End of Text	03	^C
EOT	End of Transmission	04	^D
ENQ	Enquiry	05	^E
ACK	Acknowledge	06	^F
BEL	Bell	07	^G
BS	Backspace	08	^H
HT	Horizontal Tabulation	09	^I
LF	Line Feed	0A	^J
VT	Vertical Tabulation	0B	^K
FF	Form Feed	0C	^L
CR	Carriage Return	0D	^M
SO	Shift Out	0E	^N
SI	Shift In	0F	^O
DLE	Data Link Escape	10	^P
DC1	Device Control 1	11	^Q
DC2	Device Control 2	12	^R
DC3	Device Control 3	13	^S
DC4	Device Control 4	14	^T
NAK	Negative Acknowledge	15	^U
SYN	Synchronous Idle	16	^V
ETB	End of Transmission Block	17	^W

Characters	Explanation	Hexadecimal code	Control characters
CAN	Cancel	18	^X
EM	End of Medium	19	^Y
SUB	Substitute	1A	^Z
ESC	Escape	1B	^[
FS	File Separator	1C	^\
GS	Group Separator	1D	^]
RS	Record Separator	1E	^^
US	Unit Separator	1F	^_
SP	Space	20	
DEL	Delete	7F	

Parts list

For adult ventilation

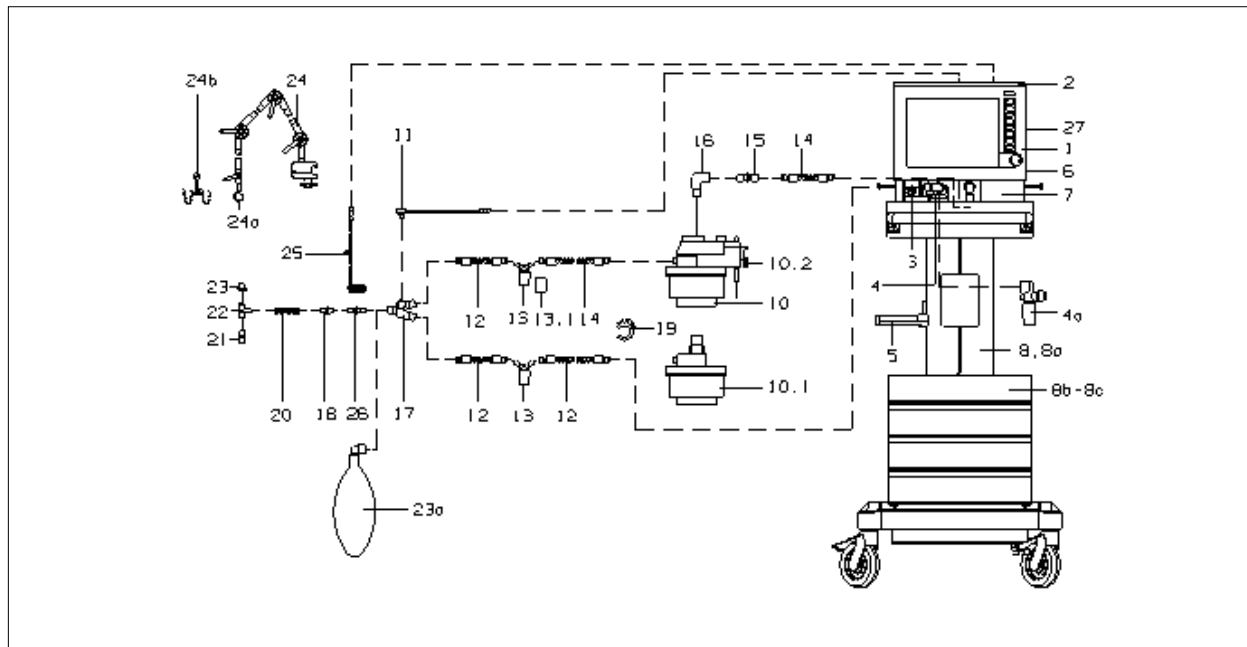

Item No.	Name/Description	Order No.
1	EvitaXL	84 14 900
2	Instrument tray	84 14 828
3	SpiroLife flow sensor, can be autoclaved	MK 01 900
or	Spirolog flow sensor (set of 5)	84 03 735
4	Expiration valve (patient system)	84 10 580
or	Disposable expiration valve (set of 10)	84 14 776
5	Humidifier holder	84 11 956
6	O ₂ sensor housing	68 50 645
7	Ambient air filter	84 12 384
7a	Cooling air filter (Rear of EvitaXL not illust.)	84 12 384
8	"EvitaMobil" trolley (high)	84 11 950
8a	"EvitaMobil" trolley (low)	84 11 965
8b	"EvitaMobil" cylinder holder set (not illust.)	84 11 970
8c	Breathing air compressor (not illust.)	84 13 890
10	Aquapor EL	84 14 698
10.1	Patient part, Aquapor EL	84 05 029
10.2	Set of spare brackets	84 03 345
11	Temperature sensor	84 05 371
12-23	Hose set, adults (blue sockets)	84 12 092
12	Spiral hose, adults, silicone 0.6 m	21 65 627

Item No.	Name/Description	Order No.
13-13.1	Water trap	84 04 985
13.1	Water container	84 03 976
14	Spiral hose, adults, silicone 0.35 m	21 65 619
15	Connector	M 25 647
16	ISO elbow connector	M 25 64
17	Y-piece, straight	84 05 435
18	Catheter connector, straight, size 12.5 (set of 10)	M 23 841
19	Hose clamp	84 03 566
20	Corrugated hose	84 02 041
21	Catheter connector, adult Set of catheter connectors, adult size 6 to 12 (set of 12)	84 03 685
22	Adaptor, adults	84 03 076
23	Cap (set of 5)	84 02 918
23a	Adult test lung (bag)	84 03 201
24-24b	Hinged arm	84 09 609
or	Quick-fix hinged arm 2	2M 85 706
24a	Bracket	84 09 746
24b	Hose clamp	84 09 841
25	CO ₂ main flow sensor	68 70 300
26	Cuvette, adults	68 70 279
27	Holder for parking CO ₂ sensor	84 12 840

For paediatric ventilation

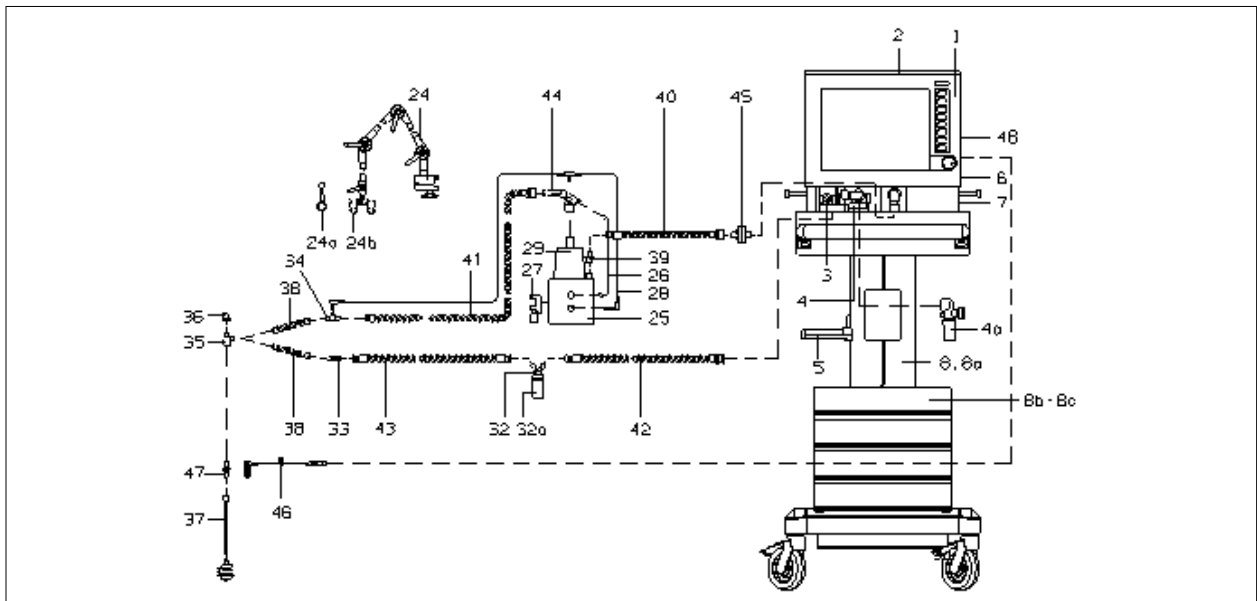

Item No.	Name/Description	Order No.
1	EvitaXL	84 14 900
2	Instrument tray	84 14 828
3	SpiroLife flow sensor, can be autoclaved	MK 01 900
or	Spirolog flow sensor (set of 5)	84 03 735
4	Expiration valve (patient system)	84 10 580
5	Bracket	84 11 956
6	O ₂ sensor housing	68 50 645
7	Ambient air filter	84 12 384
7a	Cooling air filter (Rear of EvitaXL not illust.)	84 12 384
8	"EvitaMobil" trolley (high)	84 11 950
8a	"EvitaMobil" trolley (low)	84 11 965
8b	"EvitaMobil" cylinder holder set (not illust.)	84 11 970
8c	Breathing air compressor (not illust.)	84 13 890
24-24b	Hinged arm	84 09 609
or	Quick-fix hinged arm 2	2M 85 706
24a	Bracket	84 09 746
24b	Hose clamp	84 09 841
27-28	Basic unit humidifier MR 850 German version 220 V	84 14 144
26	Hose heater adapter	84 14 968
27	Mounting set (clamps for rail)	84 11 074
28	Double temperature sensor	84 14 989
29-30	Humidifier chamber MR 340 incl. 100 pcs. absorbent paper	84 11 047
30	Absorbent paper for MR 340 (set of 200, not illust.)	84 11 073

Item No.	Name/Description	Order No.
31	Single-strand wire 1.5 m (not illust.)	84 11 050
32-43	Dräger hose set for Mr 850 inspiratory limb heated, expiratory limb water trap	84 14 987
32-32a	Condensation trap, expiration	84 09 627
32	Water container	84 03 976
33	Double conical connector	84 09 897
34	Temperature sensor mounting	84 11 044
35	Adapter K90	84 03 075
36	Cap	84 01 645
37	Bellows, paediatric, complete	84 09 742
38	Corrugated hose, flex, 0.13 m	84 09 634
39	Catheter connector, size 11	M 19 351
40	Spiral hose, paediatric, silicone 22/10, 0.40 m	21 65 856
41	Spiral hose, paediatric, silicone 22/10, 1.10 m	21 65 651
42	Spiral hose, paediatric, silicone 22/10, 0.60 m	21 65 821
43	Spiral hose, paediatric, silicone 10/10, 0.60 m	21 65 848
44	Hose heater 1.10 m	84 11 045
45	Bacterial filter	MX 02 650
46	CO ₂ main flow sensor	68 70 300
47	Cuvette, paediatrics	68 70 280
48	Holder for parking CO ₂ sensor	84 12 840

Order list

Name/Description	Order No.	Name/Description	Order No.
Basic machine		Basic machine	
EvitaXL	84 14 999	Hose sets, disposable, for MR 850, paediatrics, incl. humidifier chamber MR 290 (F&P RT 225), set of 10	84 14 994
Modification set – from Evita 4 to EvitaXL	84 14 879	Hose heater adapter MR 850 for disposable RT hose sets, adults and paediatrics (F&P 900 MR 801)	84 14 992
Modification set – from Evita 2 dura to EvitaXL	84 14 880	Temperature and flow sensor for MR 850 for disposable and reusable hose sets, 1.1 m (F&P 900 MR 868)	84 14 989
Accessories required for operation		Cover for flow sensor, blue	84 14 714
Hinged arm	84 09 609	Accessories for humidifier with F&P for MR 850	
or		Draw wire 1.5 m for reusable hose sets	84 11 050
Quick-fix hinged arm 2	2M 85 706	Humidifier chamber MR 340 incl. 100 pcs. absorbent paper	84 11 047
O2 connecting hose 3 m, white	M 35 490	Absorbent paper refill pack for humidifier chamber MR 340	84 11 073
or		Humidifier chamber MR 370 incl. 100 pcs. absorbent paper	84 12 217
O2 connecting hose 5 m, white	M 35 491	Absorbent paper refill pack for humidifier chamber MR 370	84 12 218
or		Disposable humidifier chamber MR 290 set of 10	84 18 282
O2 connecting hose 3 m, neutral colour	M 36 005	Disposable humidifier chamber MR 290 set of 40	84 18 283
or		Humidifier holder	84 11 956
O2 connecting hose 5 m, neutral colour	M 36 006	Mounting set (rail brackets)	84 11 074
Medical air connecting hose, 3 m, black/white	M 35 496	Bacterial filter	MX 02 650
or		Humidifier with Aquapor EL	
Medical air connecting hose, 5 m, black/white	M 35 497	Aquapor EL humidifier	84 14 698
or		Temperature sensor	84 05 371
Medical air connecting hose, 3 m, neutral colour	M 36 011	Humidifier holder	84 11 956
or		Set of spare brackets	84 03 345
Medical air connecting hose, 5 m, neutral colour	M 36 012	Hose set, adults, consisting of: patient hoses, water traps, Y-piece, catheter connectors	84 12 092
Humidifier with F&P MR 850		Patient part Aquapor EL	84 05 029
Basic unit humidifier MR 850 German version 220 V	84 14 720	Replacement set of lids for Aquapor EL	84 06 135
Dräger hose set for MR 850, adults, inspiratory limb heated, expiratory limb water trap	84 14 986	Aquapor EL bowl	84 05 739
Dräger hose set for MR 850, paediatrics, inspiratory limb heated, expiratory limb water trap	84 14 987	Float for Aquapor EL	84 04 738
Hose heater adapter MR 850 for Dräger hose sets, adults and paediatrics, (F&P 900 MR 858)	84 14 968	Humidifier with HME	
Hose sets, disposable, for MR 850, adults, incl. humidifier chamber MR 290 (F&P RT 212), set of 10	84 14 991	Dräger hose set for HME, adults, consisting of patient hoses, Y piece	84 12 860

Name/Description	Order No.
For CO₂ measurement (optional)	
Test filter	68 70 281
Calibration set	84 12 710
Test gas cylinder 5 Vol.% CO ₂ , 95 Vol.% N ₂	68 50 435
CO ₂ main flow sensor CapnoSmart	68 71 500
Holder for parking CO ₂ sensor	84 12 840
Special accessories	
Instrument tray, complete	84 14 828
Wall bracket, module 2000 Type 13 Alternatively to trolley	84 08 613
Pneum. Medicament nebuliser	84 12 935
For manual ventilation:	
Resutator 2000	21 20 046
Child Resutator 2000	21 20 984
Baby Resutator	21 20 941
Hook for Resutator	M 26 349
Adult test lung	84 03 201
"EvitaMobil" trolley (high)	84 11 950
"EvitaMobil" trolley (low)	84 11 965
For trolley:	
Cabinet 8H, 360 mm high (4 drawers)	M 31 796
Cabinet 4H (2 drawers)	M 31 795
"EvitaMobil" cylinder holder set	84 11 970
Set of cabinet mountings for trolley	84 09 018
Modification set – socket strip	84 11 814
Breathing air compressor for supplying EvitaXL with medical air	84 13 890
MEDIBUS cable	83 06 488
Printer cable	83 06 489
Water trap for expiration valve	84 13 125
ILV cable Evita 4/XL	84 11 794
ILV cable Evita 1/2	84 11 793
DC battery 12 V/17 Ah (one battery) (2 (two batteries required)	18 43 303
Battery cable set	84 11 822
Battery cable set MB	84 15 582

Name/Description	Order No.
Options	
Modification set – communications	84 11 735
Modification set – NeoFlow	84 15 940
Modification set – SmartCare	84 15 941
Modification set – SmartCare Capno Package	84 15 942
Modification set – Lung Protection Package	84 15 945
Modification set – O ₂ Therapy	84 15 946
Modification set – Breathing Support Package	84 13 562
Modification set – Mask ventilation (NIV)	84 14 474
Modification set – Nurse call	84 14 476
Plug for connecting the nurse call	18 46 248
Modification set – Evita Remote	84 14 472
Modification set – Capno Plus	84 13 780
Modification set – PPS	84 14 875
Modification set – DC module	84 13 034
Modification set – DC power supply MB	84 15 581
Spare set for sterilisation	
SpiroLife flow sensor	MK 01 900
Expiration valve (patient system)	84 10 580
Water trap for expiration valve	84 13 125
Temperature sensor	84 05 371
Pneum. Medicament nebuliser	84 12 935
Cuvette, adults	68 70 279
Cuvette, paediatrics	68 70 280
Replacement parts	
For EvitaXL:	
O ₂ sensor housing	68 50 645
Spirolog flow sensor (set of 5)	84 03 735
Disposable expiration valve (set of 10)	84 14 776
Set of ambient air filters/cooling air filters (set of 10)	84 11 724
Cooling air filter DC power supply MB	84 15 572
Lithium battery for data protection	18 35 343
For hinged arm:	
Bracket	84 09 746
Hose clamp	84 09 841
For adult ventilation:	
Temperature sensor	84 05 371
Spiral hose, adults, silicone 0.6 m	21 65 627
Spiral hose, adults, silicone 0.35 m	21 65 619
Water trap	84 04 985
Water container	84 03 976

New features in EvitaXL SW 6.n

Individual screen configuration storage

For storing the configuration of the curves, measured values and function keys displayed on the main screen in up to six different memory locations.

Automatic P 0.1 procedure

For performing the procedure automatically in the set interval.

Configurable Flowtrigger

Start setting for the Flowtrigger is configurable for the start according to patient mode or weight.

Extended setting range for P_{insp}, ASB and PEEP

- P_{insp} adjustable from 0 to 95 mbar (previously 0 to 80 mbar)
- ASB adjustable from 0 to 95 mbar (previously 0 to 80 mbar)
- PEEP adjustable from 0 to 50 mbar (previously 0 to 35 mbar)

Additional settings for APRV

- T_{low} in 0.05 second increments

Conclusive display of PASB

- ΔPASB for settings relative to PEEP
- PASB for absolute settings

Simplified setting for standby

- Press the key » Start/Standby« and keep it depressed for 3 seconds.

As for Evita 4 and Evita 2 dura.

ATC for the mandatory phase can be switched off

ATC is only effective during the spontaneous breathing phase or during the entire breathing cycle.

O₂ Therapy (optional)

Continuous flow application with adjustable O₂ concentration and flow for the oxygen therapy.

Lung Protection Package (optional)

Comprises the functions:

- QuickSet
Direct adjustment,
- PressureLink
PEEP/P_{insp} connection,
- Recruitment trends and
- Low Flow PV-Loop

Aid for performing Recruitment procedures and for optimising ventilation settings.

Additions to SmartCare/PS (optional, separate Instructions for Use)

- Extended area of application
- ATC can be activated
- Web-based application service (WAS)

Index

Abbreviations	232	Calibration	106
Accessories	5	Care list	162
Additional functions	91	Check before Use	34
Adjustment		Cleaning	159
direct	18	CO ₂ calibration	
directly and linked	20	resetting	117
linked	19	with calibration gas	113
Alarm	80	with test filter	112
suppression	82	CO ₂ sensor	
volume	126	calibrating	110, 115
Alarm limits		disinfect	160
define start-up values	142	fitting	29
setting	79	removal	156
Alarm, power failure alarm	82	CO ₂ zero calibration	111
Ambient conditions	188	Configuration	125
Analogue interface	181	Connect the RS 232 interface	179
Apnoea Ventilation setting	69	Control unit	12
APRV		positioning	22
Description	215	What's what	184
setting	62	Covering grid for patient part, heating	168
Technical data	189	CPAP-ASB setting	63
ASB	216	Curves, configuration	127
ASCII characters used	237	DC power operation	170
Assembling	163	DC power supply	
ATC		operation	170
Description	221	Technical data	200
setting	72	DC socket	170, 173
Technical data	189	Description	207
AutoFlow		Device check	34
Description	209	Diagnostic functions	9, 98
setting	71	Direct current	
Back panel, What's what	186	Technical data	200
Bacterial filter	25	Disinfecting	159
Battery		Dismantling	156
charge indication	172	Displaying graphics	83
charge state	172	Disposal	168
charging	171	Entering the humidifier type	40
charging times	172	Equipment outputs	198
disposal	168	Evita 4 Link	178
external	173, 176	Evita 4 Link (optional)	177
integrated	175	Evita Remote	31
Service	172	Expiration Hold	97
Bibliography	235	Expiration valve	
BIPAP		disinfect	161
Description	213	dismantling	158
setting	59	fitting	23
BIPAPAssist		mounting	163
Description	215	Ext. Flow	232
setting	61		
Breathing Support Package, Technical Data	190		
BTPS	218		

Fault – Cause – Remedy	144	Mains power	170, 175
Fault – Cause – Remedy	143	Mains power/DC power operation	169
Filter	167	Maintenance	166
Flow compensation, external	107	Maintenance/Disposal	165
Flow Measurement, description	218	Manual	
Flow sensor		Expiration	97
calibrating	106	Inspiration	96
fitting	23	ventilation device	6
removal	158	Mask, ventilation	76
Flowtrigger setting	68	Materials, used	197
Freeze	85	Measured values	
Front connections, What's what	185	Customised values	131
		display	88
Gas supply	31	System-specific values	128
Gas switch-over	9	Technical data	192
		Measurement principles	219
Heat moisture exchanger	25, 40	Medicament nebuliser	
HME	25, 40	disinfect	161
Hose system	27, 28	dismantling	157
Humidifier		use	91
conditioning	159	MMV	
Connecting AquaporEL	26	Description	212
Fisher & Paykel fitting	28	setting	52
ILV setting	53	Mobile telephone	6
Insp. O ₂ concentration during nebulisation	228	Monitoring	6, 9
Inspiration hold	96	Technical data	195
Intended Medical Application	7, 8	Nebulisation	91
Interface		NIF	101
connecting analogue	179	Description	225
RS 232 connection	179	NIV mask ventilation (optional)	76
setting	136	NTPD	218
Interruption of power supply	30	Nurse call	
Intrinsic PEEP		connecting	33
Description	226	Technical data	197
setting	100	O ₂ sensor	
IPPV setting	49	calibrating	109
Keys	14	capsule fitting	24
Knobs	14	disposal	168
Leak test	39	O ₂ Therapy	121
Leakage compensation, description	220	Technical data	190
Liability	5	Occlusion pressure P 0.1	98
Logbook	89	Description	224
Loops		Operating concept	11
configuration	127	Operating concept, optional	18
display	85	Operating data	196
Low Flow PV-Loop	102	Operation	43
Description	227	Order list	242
Lung Protection		Oxygen enrichment for bronchial suction	94
Package	9, 18, 19, 20, 84, 102, 227	Paediatric ventilation	28
LUST protocol	180	Parts list	240
Technical data	201	Patient range, set start-up value	137
		PEEP _i	
		Description	226
		setting	100

Performance characteristics	191	Sterilisation	161
PLV setting	75	Suction	94
Power failure alarm	82	Supplements	8
Power supplies	171	define start-up values	141
Power supply and connections	30	setting	66
Power supply, displays	174	Switching off monitor functions	118
Power switch	35, 45	Switching on	45
PPS		Symbols	234
Description	217	Technical Data	187
setting	64	Temperature sensor	
Preparing	155	disinfect	160
Preparing for use	21	fitting	27
Pressure limitation, manual	208	removal	156
Pressure Limited Ventilation	75	Test lung	34
PressureLink	19	Transferring a patient within the hospital	41
QuickSet	18	Trend	
Recruitment Trend	83	(1 to 24 hr) display	90
Remote Pad	31	Display (1 hr)	87
Removing and reinserting ambient-air filter	167	Graphics configuration	127
Replace cooling air filter	167	Measured value configuration	129
RSB, Description	225	Tube compensation	72, 221
Safety	5	UMDNS code	196
Safety checks	166	Unit	
Screen	13	disinfect	160
brightness	127	disposal	168
Function key assignment	130	Ventilating adults	
keys	16	preparing	26
knobs	16	setting	47
Screen configurations	132	Ventilating children preparing	26
works settings	229	Ventilating infants	
Selecting application mode	40	preparing	28
Select date	135	setting	47
Select language	134	Ventilation hoses	
Select MEDIBUS protocol	180	connecting (adults)	26
Select printer protocol	181	disinfect	161
Select time	135	fittings (infants)	28
Sensors	106	removal	157
Service	166	Ventilation Modes	8
Set units	135	Description	208
Settings	188	setting	48
customised	131	setting start-up value	138
lock access	134	Ventilation parameters	
specific systems	126	new setting	47
Sigh		setting	17
Description	210	Volume	126
setting	74	Weaning parameters, description	224
SIMV		What's what	183
Description	211		
setting	50		
Socket strip	30		
Standby	119		
Start-up			
measured values	128		
settings, for specific therapy	137		
values, setting	140		

These Instructions for Use only apply to

EvitaXL SW 6.n

with the Serial No.:

If no Serial No. has been filled in by Dräger these Instructions for Use are provided for general information only and are not intended for use with any specific machine or device.



Directive 93/42/EEC
concerning Medical Devices

Dräger Medical AG & Co. KGaA
Germany

🏠 Moislinger Allee 53 – 55

D-23542 Lübeck

☎ +49 451 8 82- 0

FAX +49 451 8 82- 20 80

💻 <http://www.draeger.com>

90 38 308 – GA 5664.650 en

© Dräger Medical AG & Co. KGaA

1st edition – July 2004

Subject to alteration