

## TECHNICAL PRE QUALIFICATION REQUIREMENT

Name of Project :- **132 KV SWITCHYARD EXTENSION AT BARAUNI TPS**  
Name of Customer :- **NTPC Limited**  
Name of Item :- **FIRE FIGHTING SYSTEM FOR 132KV Switchyard Extension**

### TECHNICAL PRE QUALIFICATION REQUIREMENT

1. The bidder should have supplied, erected & commissioned at least one number fire protection system of each type described in (a) & (b) below in installations such as power plants, sub-stations, refineries, fertilizer plants or other industrial or commercial installations during the last 10 years as on original technical bid opening date of this tender.
  - a) Hydrant type fire protection system comprising of pipe work, hydrant valves, hoses with branch pipes etc.
  - b) Addressable smoke detection and alarm System
2. The supplied firefighting system should be in successful operation for at least 01(one) years in last 10 years as on originally scheduled date of technical bid opening of BHEL tender.

### SUPPORTING DOCUMENTS TO BE ATTACHED

| Sr | Required Criteria    | Supporting Documents to be submitted by bidder along with technical bid  |
|----|----------------------|--|
| 1  | Supply               | Copy of POs/Material receipt certificate at site, etc.   |
| 2  | Commissioning/ETC    | Pre commissioning report / commissioning report etc.   |
| 3  | Successful operation | Successful operation means certificate issued by the Customer certifying the operation without any adverse remark. |

#### Notes (General points):

1. Consideration of offer shall be subject to customer's approval of bidder's, if applicable.
2. Bidder to submit all supporting documents in English. If documents submitted by bidder are in language other than English, a self- attested English translated document should also be submitted.
3. Notwithstanding anything stated above, BHEL reserves the right to assess the capabilities and capacity of the bidder to perform the contract, should the circumstances warrant such assessment in the overall interest of BHEL.
4. After satisfactory fulfilment of all the above criteria / requirement, offer shall be considered for further evaluation as per NIT and all the other terms of the tender.

*S Kumar.*  
26/09/22

PREPARED BY  
Sudhir Kumar  
Dy. Mgr/TBEM

*Tripathi*  
26/9/22

REVIEWED BY  
TD Tripathi  
Mgr/TBEM

*Vivek Kapil*  
26.9.22

APPROVED BY  
Vivek Kapil  
AGM/TBEM



भारत हेवी इलेक्ट्रिकल्स लिमिटेड  
**BHARAT HEAVY ELECTRICALS LIMITED**

पारेषण व्यापार अभियांत्रिकी प्रबंधन  
**TRANSMISSION BUSINESS ENGINEERING MANAGEMENT**

COPYRIGHT AND CONFIDENTIALITY  
The information on this document is the property of BHARAT HEAVY ELECTRICALS LTD.  
It must not be used directly or indirectly in anyway detrimental to the interest of the company

|                       |   |          |   |                    |   |                       |          |
|-----------------------|---|----------|---|--------------------|---|-----------------------|----------|
| प्रलेख संख्या DOC. No | TB-374-552-36   | Rev. No. | 0 | बनाया/<br>Prepared | जांचा/<br>Checked                                 | स्वीकृती/<br>Approved |          |
| TYPE/ प्रकार OF DOC   | TECHNICAL SPECIFICATION                               |          |   | हस्ता. / SIGN      | <i>Skumar</i> <i>Devichand</i> <i>K. S. Gupta</i> |                       |          |
| TITLE/ शीर्षक         | FIRE FIGHTING SYSTEM<br>(132 kV Switchyard Extension) |          |   | नाम / NAME         | SK  | TDT                   | VK       |
|                       |   |          |   | दिनांक/ DATE       | 21-09-22  | 21-09-22              | 21-09-22 |
|                       |   |          |   | समूह/GROUP         | TBEM  | W.O. No               | 83009    |
| ग्राहक/<br>CUSTOMER   | NATIONAL THERMAL POWER CORPORATION (NTPC)             |          |   |                    |   |                       |          |
| परियोजना/<br>PROJECT  | 132 KV SWITCHYARD EXTENSION AT BARAUNI TPS            |          |   |                    |   |                       |          |

विषय-सूचि/ CONTENTS

| अनुभाग / Section | विवरण / Description                                   | पृष्ठ संख्या/ No of Pages |
|------------------|---|---------------------------|
| 1                | Intent, Design criteria, System requirement and scope | 09                        |
| 2                | Equipment Specification                               | 02                        |
| 3                | Project details and general technical requirements    | 12                        |
| 4                | List of Documents                                     | 01                        |
| 5                | Schedule to be filled by Bidder                       | 05                        |

ENCLOSURES

- ANNEXURES TO SECTION - 1  
Annexure-I – List of cables procured by BHEL.
- ANNEXURES TO SECTION - 5  
Annexure-A - Layout Plan for 220/132 kV Switchyard.  
Drawings for Fire fighting system

| Rev No.      | Date | Altered | Checked | Approved | REVISION DETAILS |      |      |        |
|--------------|------|---------|---------|----------|------------------|------|------|--------|
| Distribution |      |         |         | To       | TBEM             | TBMM | TBQM | Vendor |
|              |      |         |         | Copies   | 1                | 1    | 1    | 4      |

## SECTION -1

### INTENT , SYSTEM REQUIREMENT , DESIGN CRITERIA, AND SCOPE

#### 1.0.0 INTENT OF SPECIFICATION

- 1.1 This specification covers the bidder's scope viz. *manufacture, inspection and testing at bidder's and/ or his sub-vendor's work(s), proper packing for transportation, transport & delivery of equipment at site, erection, testing, & commissioning of Fire Detection cum Protection System* as detailed in this section and in various other sections of this specification for **132 kV Switchyard Extn. of 2 x 250 MW, Barauni TPS of NTPC Ltd.**
- 1.2 The requirement(s) specified under 'SECTION 2, SECTION 3, SECTION 4' and 'SECTION 5' of this specification shall be considered as part of this section. In case of variance between sections the requirements of Section-1 shall prevail.
- 1.3 It is not the intent to specify herein all the details of design and manufacture. However, the equipment shall conform in all respects to high standards of design, engineering and workmanship and shall be capable of performing the required duties in a manner acceptable to Purchaser/ Owner, who will interpret the meaning of drawings and specifications and shall be entitled to reject any work or material, which in his judgment is not in full accordance herewith.
- 1.4 It shall be the responsibility of successful bidder to obtain necessary approval(s) /clearance(s) from statutory organization(s) / authority(s) wherever applicable for the equipment / system / sub-system(s) under the scope specified herein.
- 1.5 The bidder shall be deemed to have understood completely all the tender drawings and documents and quoted accordingly.
- 1.6 The bidder has to note carefully the parameters, estimated capacities of equipment indicated and the tender drawing in the specification are only for guidance of the bidder. The system is designed as per relevant standards/ codes and exact capacities and quantities are to be estimated by the bidder.
- 1.7 In case of any deviation, the bidder shall indicate separately the deviations clause-wise with respect to the specification in the 'Schedule of Deviation'. Deviations in any other form including clarifications/ assumptions etc. will not be considered and it will be construed that the bid conforms strictly to the specification.
- 1.8 The **contract** shall be on **Unit Rate Basis** for the package. In case of change in the input after placement of order the additions / deletions to the scope shall be settled on the basis of unit rates agreed between the Purchaser and Contractor.
- 1.9 *During contract stage, quantities of various items of BOQ may vary to any extent and same rates will be applicable so far the resultant variation in total contract value is within  $\pm 30\%$ . Variations beyond  $\pm 30\%$  shall be negotiated mutually.*

|   |                 |
|---|-----------------|
| Project: 132 kV Barauni Switchyard Extn. at Barauni TPS | TB-374- 552- 36 |
| Customer: NTPC  | Section - 1     |
| Contractor: Bharat Heavy Electricals Limited            | Rev - 0         |
| Switchyard Fire Fighting System                         |                 |

1.10 The Purchaser and Owner in this specification stand for **BHEL** and **NTPC** respectively. The successful bidder shall be referred to as Contractor.

## 2.0.0 SYSTEM REQUIREMENTS AND DESIGN PHILOSOPHY.

2.1 Design/ engineering activity of this order is already done and approved drawings, data sheets are provided as enclosure to this specification. Bidder shall quote to this tender as per approved drawings in conjunction to clauses mentioned under Cl. No. 3.1.2 & Cl. No 3.2 of this section.

This system is designed to provide fire detection and protection services for Bay control room in switchyard area. Design criteria is based on "Ordinary Hazard Occupancies" classification as described in Tariff Advisory Committee's (TAC) guidelines. All equipment or systems in the designed fire detection cum protection arrangement are completely in compliance with the regulations of Tariff Advisory Committee (TAC) of India / Loss Prevention Association (LPA) / National Fire Protection Association (NFPA).

2.2 Fire protection scheme envisaged under this specification shall be broadly classified as follows.

| SYSTEM                        | AREAS PROTECTED            |
|-------------------------------|----------------------------|
| <b>FIRE DETECTION SYSTEM</b>  |                            |
| Smoke Detection System        | Bay Control rooms (5 nos.) |
|                               |                            |
| <b>FIRE PROTECTION SYSTEM</b> |                            |
| Hydrant System                | 132 kV Switchyard area     |
| Portable Extinguisher         | Bay Control rooms (BCR)    |

## 2.3 DESIGN FEATURES

### 2.3.1 Detection System

#### General

- Addressable, analogue/intelligent Multisensor smoke detectors shall be provided (2 nos.) in each of the bay control rooms which will be looped in to a Fire Alarm panel (FAP) of Schrack- Seconet make located in adjacent existing 220 kV switchyard control room.
- All the circuits from the detectors to the panels shall be closed loop type and shall be supervised for open and short circuiting.
- Loop detection cable for signaling line circuit shall be armored flame retardant low smoke cable (FRLS) type which will be used for connecting detectors, modules, call points and networking of panels & control cables, power cables for Notification appliances.
- Fire detection & alarm system shall be interfaced with independent air conditioning system for Bay control room i.e. BCR so that in case of any fire in any BCR, AC system specific to that area can be tripped. Control relay module in each BCR shall be provided to initiate the trip of AC system in that area.

- e. Necessary isolator module etc. required to make the system function satisfactorily shall be supplied by the contractor as per requirement.
- f. Manual call points (Break glass alarm stations) shall be provided near each BCR.

**Specific Details:**

- a. Multisensor detectors shall conform to NFPA-72 standards.
- b. Area Coverage for each smoke detector shall be as per TAC guidelines.
- c. However other factors like beam depth and area separation criterion shall also be implemented in deciding coverage of each of the detectors.
- d. Incipient fires sensed by these detectors shall trigger an alarm at the FAP.
- e. Complete system and all equipment such as detectors etc shall be approved and listed by UL/FM/LPCB/VDS/TAC.
- f. The complete system shall include, but not be limited to the following :
  - 1. Analog addressable smoke detectors.
  - 2. Complete Wiring/ cabling.
- g. Field testing facility shall be provided by the system for either the complete system specified area or a specified device while maintaining full function of areas not under test.
- h. All devices shall be individually identifiable for its type, its zone location, and alarm set value, alarm and trouble indication by a unique alpha numerical label.
- i. The detectors shall be self-compensating for ambient temperature and humidity.
- j. The detectors shall display a steady LED when in the alarm state. The LED shall flash when in standby or normal mode.

### 2.3.2 Hydrant System

#### 2.3.2.1 Fire Protection System

- a. Hydrant systems for the switchyard area shall be tapped off from the nearest hydrant header of adjacent 220 kV switchyard. Fire water piping layout with Tap-off point indicated is enclosed. Water from this tap off shall be routed to the 132 kV switchyard extn.
- b. Hydrant system has been designed so that minimum required water pressure shall be available at the farthest point of the switchyard. Min pressure requirement of 3.5 Kg/ Sq.cm at the farthest point shall be available after considering all the head losses and also the operation of two hydrants simultaneously.
- c. Hydrant system is designed for Ordinary Hazard Classification.
- d. All the outdoor hydrants shall be provided with a front glass type hose box carrying 2 nos. 15 mtrs. hose along with branch pipe coupling and nozzle.
- e. **All hydrant pipe mains/ pipe lines shall be routed over ground on RCC pedestals.** Road, Rail or pipe trench crossing shall be through RCC Hume pipes duly covered with coating and wrapping as per specification. Hume pipe for road crossing shall be NP2 class and that for rail crossing shall

be NP3. Substation areas where movement of cranes/ vehicles is expected and where laying of pipes above ground is not advisable, pipes shall be laid underground.

- f. Surface of all over ground pipes shall be thoroughly cleaned of mill scale, rust etc. by wire brushing. Thereafter one coat of red lead primer shall be applied. Finally two coats of synthetic enamel paint shall be applied. For underground piping coating & wrapping shall be done with two coats of coal tar/ hot enamel paint & two wraps of reinforced fibre glass tissue. The total thickness of wrapping and coating shall not be less than 4 mm. Wrapping & coating shall be inline with IS: 10221. *Supply of primer/ paints, wrapping coating etc. shall be in contractor's scope.*

### 2.3.2.2 Specific Data

- i) All hydrant valves shall be of 63 NB dia. Single headed, oblique type having stainless steel construction conforming to IS: 5290, Type-A.
- ii) Hoses shall be of non-percolating flexible type as per IS: 636 (Type-A) or Equivalent.
- iii) **PIPING**

Specific features of piping for Fire Protection System shall be as follows: -

- a) All the pipes shall be of medium grade with thickness as 6.35 mm for sizes 200 NB and above.
- b) The pipe protection shall be as follows: To prevent soil corrosion, buried pipes shall be properly lagged with 4 mm thick wrapping and coating corrosion protection tape as per IS: 10221. Tests to be carried out after application: Bond/ Adhesion test, Holiday test by the bidder.

#### A. Above ground piping

- a. Material MS for Hydrant system
- b. Standard (Pipes) IS 1239/ IS 3589
- c. Standard (Fitting) IS 1239 part II/ TAC
- d. Class Medium
- e. Type of joint Welded / Flanged
- f. Type of protection: Painted (Two coats of Grey zinc primer. Two coats of enamel paint of 75 microns thickness with color shade conforming to IS: 5).

#### B. Underground piping

- a. Material MS
- b. Standard (Pipes) IS 3589/ IS 1239 Part – I
- c. Standard (Fitting) IS 1239 part II for fittings NB 150 & below & Fabricated from parent pipes for NB 200 & above.
- d. Type of joints Welded

e. Type of protection IS 10221/ IS 15337-2003

### C. Fittings

Unless otherwise specified all elbows/ bends shall be long radius type.

All the fittings the material shall be mild steel shall be IS 1239 Part-II up to 150 mm dia and above shall fabricated from parent pipe in addition to following:

- Unless otherwise specified all elbows/ bends will be long radius type.
  - The material will conform to IS-1239 part-II heavy grade /malleable iron as per IS: 1879 Part I to X
- Fittings (normally filled with water): Elbow, Tee & Reducers.
- Screwed Fittings up to 50 mm diameter
  - Butt welded fittings 65NB to 150 NB
  - Site fabricated from parent pipe and fabricated as per BS: 2633/ BS: 534
  - (90 degree elbow 3 cut, 4 piece construction. 45 deg. elbow 2cut, 3 piece construction)
  - Slip-on flanges/blind flanges as per IS: 2062 Gr .A, Dimension/ Drilling standard as per ANSI B 16.5/ IS-1538 Table IV & VI F/F.
  - SS-304 for Bolt & Nuts.

### D. Valves

All isolation valve/cut-off valves shall be CI as per IS: 210, FG 260 body, with 13% Cr. SS stem & seating surfaces of gate valves as per guidelines/requirements specified in TAC.

Valve shall have provision of locking arrangements in open and closed position.

All the flanges & counter flanges will conform to IS-2062 Gr. A Slip on (Dimension/Drilling as per ANSI B 16.5 Cl. 150. /IS: 1538)

All valves shall be of minimum class of 150.

Strainer Body shall be as per IS: 2062 (tested).

#### 2.3.3 Portable Fire Extinguishers:

Following types of portable extinguishers are envisaged for the bay control rooms (BCR) in the switchyard.

- a. Each Bay control room shall be provided with one no. of 4.5 kg capacity carbon dioxide portable extinguisher.

#### 3.1.1 SCOPE

Manufacture, testing at manufacturer's works, transportation, supply, erection, testing, & commissioning of the equipments/system at the site, outlined hereinafter, complete with all materials and accessories, are in the Bidder's scope of work. The scope of the work under the contract shall be deemed to include all such items, which although not specifically mentioned in the bid documents and/or in the bidder's proposal, but are required to make the equipment/system complete for its safe,

efficient, reliable and trouble free operation, unless the same is specifically excluded from the Bidder's scope of work under clause 3.3 of this section.

### 3.1.2 Scope of supply

- a. The Bill of Quantities shall be read in conjunction with the Instructions to Bidders, General and Special Conditions of Contract, Technical Specifications, and Drawings.
- b. The quantities given in the Bill of Quantities are estimated and provisional, and are given to provide a common basis for bidding. The basis of payment will be the actual quantities of work ordered and carried out, as measured by the Contractor and verified by the Purchaser and valued at the rates and prices bid in the priced Bill of Quantities.
- c. *A rate or price shall be entered against each item in the priced Bill of Quantities. The cost of Items against which the Contractor has failed to enter a rate or price shall be deemed to be covered by other rates and prices entered in the Bill of Quantities.*
- d. *The whole cost of complying with the provisions of the Contract shall be included in the Items provided in the priced Bill of quantities, and where no Items are provided, the cost shall be deemed to be distributed among the rates and prices entered for the related Items of Work.*
- e. General directions and descriptions of work and materials are not necessarily repeated nor summarized in the Bill of Quantities. References to the relevant sections of the Contract documentation shall be made before entering prices against each item in the priced Bill of Quantities.
- f. Miscellaneous items like hardware, fixtures, bolts, angles etc. shall be deemed to be included under the relevant BOQ items and bidders shall consider the same while quoting for BOQ items.

### BILL OF MATERIAL

| HYDRANT SYSTEM |   |          |
|----------------|---|----------|
| SL. NO.        | ITEM DESCRIPTION  | QUANTITY |
| 1.1            | SINGLE HEADED EXTERNAL HYDRANT VALVE SS CONSTRUCTION (IS:5290, TYPE-A) 63NB | 6 NOS.   |
| 1.2            | RRL FIRE HOSE 63 MM DIA X 15 MTRS LONG WITH SS COUPLING (IS: 636 (TYPE-A))  | 12 NOS.  |
| 1.3            | SS BRANCH PIPE WITH NOZZLE  | 6 NOS.   |
| 1.4            | MS FABRICATED GLASS FRONTED EXTERNAL HOSE CABINET                           | 6 NOS.   |
| 1.5            | ABOVE GROUND MS PIPE (AS PER IS: 1239 PART-1, MED. GR.)                     |          |
| 1.5A           | 100NB   | 402 MTRS |
| 1.5B           | 80 NB   | 12 MTRS  |



|   |                 |
|---|-----------------|
| Project: 132 kV Barauni Switchyard Extn. at Barauni TPS | TB-374- 552- 36 |
| Customer: NTPC  | Section - 1     |
| Contractor: Bharat Heavy Electricals Limited            | Rev - 0         |
| Switchyard Fire Fighting System                         |                 |

|  |  |          |
|--|--|----------|
| 1.6  | CI GATE VALVE  |          |
| 1.6 A  | 100 NB   | 4 NO.    |
| <b>ADDRESSABLE FIRE DETECTION &amp; ALARM SYSTEM</b> |  |          |
| 2.1  | ADDRESSABLE MULTISENSOR SMOKE DETECTOR                                   | 6 NOS    |
| 2.2  | ADDRESSABLE MANUAL CALL POINT  | 3 NOS.   |
| 2.4  | CONTROL RELAY MODULE   | 3 NOS.   |
| 2.5  | ARMOURED SCREENED AND TWISTED PAIR FRLS TYPE CABLE WITH COPPER CONDUCTOR | 550 MTRS |
| <b>PORTABLE FIRE EXTINGUISHER</b>                    |  |          |
| 3.1  | CARBON DIOXIDE TYPE PORTABLE EXTINGUISHER (4.5 KG CAPACITY)              | 3 NOS.   |
| 4.0  | RCC PEDESTALS FOR PIPE   | 70 NOS.  |

- Price of above BOQ items shall include, supply of Pipe fittings, hume pipe, Paints/ wrapping coating material to be applied on pipes/ items etc.

### 3.2. Scope of Services

#### A. Erection, Testing & Commissioning (ETC) requirements

- i) The scope of ETC shall include material, handling of equipment/ material at site, erection of equipment /material at site including fabrication, equipment and system testing, commissioning of the entire system, conducting performance guarantee tests to the satisfaction of Owner / Purchaser and final handing over to the owner of the entire system.

#### B. With Other Electrical System

- i) Preparations of cable interconnection diagram for equipment supplied under this contract and accordingly offer guidance to the purchaser for laying necessary cables. Termination details shall also be furnished in the said interconnection table.
- ii) Laying & Termination of Power and Control cables for the equipment under the scope of this specification. Bidders shall include all cable accessories like lugs, glands, cable tags, markers etc in their respective bids.
- iii) Earthing of all installations (to the nearest earth mat/ earthing pad) supplied under the scope of this specification.

#### C. With Civil System

- i) Supply & Laying of hume pipes as per requirements of approved layout drawings.
- ii) Making RCC pedestals for above ground piping wherever required.

D. All machinery tools & tackles and consumables required for erection/ testing / commissioning of the system shall be arranged by the Bidder.

E. Minor modifications, alterations in system installation as per customer's specific requirements shall be

done without any extra cost to purchaser.

- F. Bidders to ensure that sufficient quantity of spares are made available for timely completion of commissioning of the system. The bidder shall furnish a list of commissioning spares that will be brought by him. The unused commissioning spares shall be returnable to the bidder.
- G. Obtaining approval from TAC/ TAC accredited / Equivalent agency on documents & installations.
- i) Obtaining, "As Built" certification from purchaser or owner on applicable drawings. Completing documentation as per specification requirement.
- ii) Obtaining customer's written acceptance of satisfactory completion of job. (Acceptance of PG + handing over of plant.
- iii) Any other service not explicitly illustrated herein but which may be required to complete the system with its desired functionality or in the spirit of contract shall also deemed to be under the scope of bidder.

#### H. Civil Works

The Bidder shall supply and install U bolt, angle base required for RCC pedestals & hardwares etc and undertake minor civil works such as grouting, filling up of crevices/ cut outs etc. Any damage caused to civil works during ETC work of the equipment/system shall have to be made good to the original finish by the Contractor at no extra cost to the Purchaser.

In addition the following shall be in the scope of Contractor:

- i) Laying of underground piping and construction of RCC pedestals to support the above ground piping for hydrant wherever required.

### 3.3 Exclusions

- i. Supply of power and control cables except the cables for fire detection and alarm system. *The bidder shall furnish **quantity and type** of cables required complete system in their respective bids.*

### 3.4 OPERATION & MAINTENANCE (O&M) MANUAL

Operation and Maintenance manuals shall be specifically compiled for the project by the bidders. The draft O&M manual shall be submitted within 20 weeks after award of contract. The O&M manual shall contain the following information:

- a. Description of the system and equipment with design particulars.
- b. Instruction for operation, maintenance and repair.
- c. Recommended inspection practices and inspection schedule.
- d. Ordering information for all replaceable parts.

### 3.5 Inspection & Testing

All the equipments shall be inspected prior to dispatch in line with relevant IS, approved GTP/ drawing and technical specification, BHEL/ customer approved QAP.

**ANNEXURE- 'A'**

**CABLE SIZES BEING PROCURED BY BHEL FOR SUB-STATION**

|    |                                       |
|----|---------------------------------------|
| 1  | 2C X 2.5 sq mm PVC/Cu Control Cable   |
| 2  | 4C X 4 sq mm PVC/Cu Control Cable     |
| 3  | 4C X 6 sq mm PVC/Cu Control Cable     |
| 4  | 5C X 2.5 sq mm PVC/Cu Control Cable   |
| 5  | 10C X 2.5 sq mm PVC/Cu Control Cable  |
| 6  | 14C X 2.5 sq mm PVC/Cu Control Cable  |
| 7  | 19C X 2.5 sq mm PVC/Cu Control Cable  |
| 8  | 2C X 6 Sq.mm XLPE/Al Power Cable      |
| 9  | 4C X 6 Sq.mm XLPE/Al Power Cable      |
| 10 | 3.5 C X 35 sq mm XLPE/Al Power Cable  |
| 11 | 3.5 C X 70 sq mm XLPE/Al Power Cable  |
| 12 | 3.5 C X 120 sq mm XLPE/Al Power Cable |
| 13 | 1 C X 50 sq mm XLPE/Al Power Cable    |
| 14 | 1 C X 150 sq mm XLPE/Al Power Cable   |
| 15 | 1 C X 630 sq mm XLPE/Al Power Cable   |

## SECTION - 2

### EQUIPMENT SPECIFICATION

#### 2.0 CODES AND STANDARDS

The design, manufacture, inspection and testing of complete system shall comply with the latest applicable Indian/British/American standards. The equipment shall conform to the latest edition to the following standards:

- a. "Fire Protection Manual" - Issued by the Regional Committees of Tariff Advisory Committee (TAC).
- b. Underwriters Laboratories of USA
- c. LPCB - United Kingdom
- d. National Fire Codes of National Fire Protection Association (NFPA) of USA.
- e. IS: 3034 -Code of practice for firefighting of industrial buildings: Electrical generating and distributing stations.
- f. IS: 2189- Code of practice for selection, installation and maintenance of automatic detection and alarm system.

#### 2.1 GENERAL DESIGN AND CONSTRUCTIONAL REQUIREMENT

It is not the intent to specify herein all the details of design and manufacture. However the equipment and the system shall conform in all respects to high standards of design engineering and workmanship and shall be capable of performing the required duties in a manner acceptable to purchaser /Owner who will interpret the meaning of drawings and specifications and shall be entitled to reject any work or material which in his judgment is not in full accordance herewith.

#### 2.2 EQUIPMENT DETAILS OF HYDRANT SYTEM

- Pipes

1. *Normally filled with water:*

Mild steel as per IS 1239(Part-I) medium grade (upto 150NB) & as per IS 3589 Gr.410 (above 200NB) or equivalent.

Buried pipes shall be wrapped and coated as per IS 10221 (min thickness 4 mm).

- Single headed hydrant valve shall be of Stainless steel construction types A conforming to IS 5290.
- Fire Hoses shall be non-percolating type as per IS 636 type A or equivalent.
- Branch pipes shall be of stainless steel construction of straight jet type as per IS 903.

- Hose boxes shall be pedestal mounted, MS construction with front glass door.
- All fittings shall be as per relevant IS/BS codes and approved by TAC.
- All flanges and counter flanges shall conform to ANSI B 16.5 Cl. 150.

## **2.3 SHOP TESTS**

### **2.3.1 SHOP TESTS**

All acceptance and routine tests in accordance with relevant IS codes/standards shall be carried out by the contractor/manufacturer. Charges for all these routine and acceptance tests for all the equipment & components shall be deemed to be included in the bid price.

Contractor shall submit the QP for all such equipments calling inspection/ testing for purchaser's approval. This Owner/Purchaser approved QP shall be the basis of inspection/ testing.

## SECTION - 3 GENERAL TECHNICAL REQUIREMENTS

### 3.0 GENERAL

This section stipulates the General Technical Requirements under the Contract and will form an integral part of the Technical Specification.

The provisions under this section are intended to supplement general requirements for the materials, equipment and services covered under other sections and; is not exclusive. However in case of conflict between the requirements specified in this section and requirements specified under other sections, the requirements specified under respective sections shall hold good.

### 3.1 SITE INFORMATION

|                 | Particulars                |   |
|-----------------|----------------------------|---|
| a)              | Customer/ Purchaser/ Owner | NTPC/BHEL/ NTPC                                 |
| b)              | Project Title              | 220 kV Switchyard at Barauni TPS                |
| c)              | Location                   | Barauni / Bihar                                 |
| d)              | Postal Address             | Shall be furnished to successful bidder         |
| SITE CONDITIONS |                            |   |
| a)              | Max. ambient air temp.     | 42.4° C   |
| b)              | Min. ambient air temp.     | 8.4° C  |
| c)              | Max. design ambient temp.  | 50° C   |
| d)              | Min. design ambient temp.  | 5° C  |
| e)              | Max. RH                    | 100 %   |
| f)              | Min. RH                    | ---   |
| g)              | Height above MSL           | Less than 1000 m                                |
| h)              | Pollution Severity         | Shall be furnished to successful bidder         |
| i)              | Seismic Zone               | Zone – IV as per IS 1893                        |
| WIND DATA       |                            |   |
| a)              | Site Wind Pressure         | 50 m / sec                                      |
| b)              | Average Annual Rainfall    | 1119.1mm (Max. rain fall in 24 hrs is 352.8 mm) |

❖ ***NTPC, Barauni Or Barauni Thermal Power Station is an existing coal-fired power station earlier owned by Bihar State Electricity Board (BSEB) and currently by NTPC Limited.***

### 3.2 INSTRUCTION TO BIDDERS

The bidders shall submit the technical requirements, data and information as per the technical data sheets, provided in Section-4.

The bidders shall furnish catalogues, engineering data, technical information, design documents, drawings etc fully in conformity with the technical specification.

It is recognised that the Contractor may have standardised on the use of certain components, materials, processes or procedures different than those specified herein. Alternate proposals offering similar equipment based on the manufacturer's standard practice will also be considered provided such proposals meet the specified designs, standard and performance requirements and are acceptable to the Purchaser. Unless brought out clearly, the Bidder shall be deemed to conform to this specification scrupulously. All deviations from the specification shall be clearly brought out in the respective schedule of deviations. Any discrepancy between the specification and the catalogues or the bid, if not clearly brought out in the schedule, will not be considered as valid deviation.

Wherever a material or article is specified or defined by the name of a particular brand, Manufacturer or Vendor, the specific name mentioned shall be understood as establishing type, function and quality and not as limiting competition.

Equipment furnished shall be complete in every respect with all mountings, fittings, fixtures and standard accessories normally provided with such equipment and/ or needed for erection, completion and safe operation of the equipment as required by applicable codes, though they may not have been specifically detailed in the Technical Specifications unless included in the list of exclusions. Materials and components not specifically stated in the specification but which are necessary for commissioning and satisfactory operation of the switchyard unless specifically excluded shall be deemed to be included in the scope of the specification and shall be supplied without any extra cost. All similar standard components/parts of similar standard equipment under supply shall be inter-changeable with one another.

The Contractor shall supply type tested (including special tests as per tech. specification) equipment and materials. The test reports shall be furnished by the Contractor, along with equipment/ material drawings. In the event of any discrepancy in the test reports, (i.e., if any test report is not acceptable due to any design/ manufacturing changes or due to non-compliance with the Technical Specification and/ or applicable standard), the tests shall be carried out without any additional cost implication to the PURCHASER. The PURCHASER reserves the right to get any or all type/tests conducted/repeated.

### 3.3 STANDARDS

The works covered by the specification shall be designed, engineered, manufactured, built, tested and commissioned in accordance with the Acts, Rules, Laws and Regulations of India.

The equipment to be furnished under this specification shall conform to latest issue (with all amendments) of specified standards.

In addition to meeting the specific requirement called for in Sections 1 and 2 of the Technical Specification, the equipment shall also conform to the general requirement of the applicable standards, which shall form an integral part of the specification.

The Bidder shall note that standards mentioned in the specification are not mutually exclusive or complete in themselves, but intended to complement each other.

When the specific requirements stipulated in the specifications exceed or differ from those required by the applicable standards, the stipulation of the specification shall take precedence.

Other internationally accepted standards, which ensure equivalent or better performance than that specified in the standards referred, shall also be accepted. The bidder shall submit copies of such standards.

In case governing standard for the equipment is different from IS or IEC,, the salient points of difference shall be clearly brought out in the offer along with English language version of standard or relevant

extract of the same. The equipment conforming to standards other than IS/IEC shall be subject to Purchaser's / owner's approval.

The bidder shall clearly indicate in his bid the specific standards in accordance with which the works will be carried out.

#### 3.4 SERVICES TO BE PERFORMED BY THE EQUIPMENT BEING FURNISHED

All equipment shall also perform satisfactorily under various other electrical, electromechanical and meteorological conditions of the site of installation. All equipment shall be able to withstand all external and internal mechanical, thermal and electromechanical forces due to various factors like wind load, temperature variation, ice & snow, (wherever applicable) short circuit etc for the equipment. The equipment shall also comply to the following:

- a) All outdoor EHV equipment except marshalling kiosks shall be suitable for hot line washing.
- b) To facilitate erection of equipment, all items to be assembled at site shall be "match marked".
- c) Piping, if any, between equipment control cabinet and operating mechanism to marshalling box of the equipment shall bear proper identification to facilitate the connection at site.

#### 3.5 ENGINEERING DATA

##### 3.5.1 Drawings

All drawings submitted by the Contractor including those submitted at the time of bid shall be in sufficient detail to indicate the type, size, arrangement, material description, Bill of Materials, weight of each component, break-up for packing and shipment, the external connections, fixing arrangement required. the dimensions required for installation and interconnections with other equipment and materials, clearances and spaces required for installation and interconnections between various portions of equipment and any other information specifically requested in the specifications.

Each drawing submitted by the Contractor shall be clearly marked with the name of the Purchaser, the unit designation, the specifications title, the specification number and the name of the Project. If standard catalogue pages are submitted, the applicable items shall be indicated therein. All titles, noting, markings and writings on the drawing shall be in English. All the dimensions should be in metric units.

Further work by the Contractor shall be in strict accordance with these drawings and no deviation shall be permitted without the written approval of the Purchaser, if so required.

The review of these data by the Owner will cover only general conformance of the data to the specifications and documents, interfaces with the equipment provided under the specifications, external connections and of the dimensions which might affect substation layout. Owner may not indicate a thorough review of all dimensions, quantities and details of the equipment, material, any devices or items indicated or the accuracy of the information submitted. This review and /or approval by the Owner shall not be considered by the Contractor, as limiting any of his responsibilities and liabilities for mistakes and deviations from the requirements, specified under these specifications and documents.

All manufacturing and fabrication work in connection with the equipment prior to the approval of the drawings shall be at the Contractor's risk. The Contractor may make any changes in the design which are necessary to make the equipment conform to the provisions and intent of the Contract and such changes will again be subject to approval by the Purchaser. Approval of Contractor's drawing or work by the Purchaser shall not relieve the contractor of any of his responsibilities and liabilities under the Contract



All engineering data submitted by the Contractor after final process including review and approval by the Owner shall form part of the Contract Document and the entire works performed under these specifications shall be performed in strict conformity, unless otherwise expressly requested by the Owner in Writing.

### 3.5.2 Approval Procedure

The scheduled dates for the submission of these as well as for, any data/ information to be furnished by the Purchaser would be discussed and finalised at the time of award. The following schedule shall be followed generally for approval.

|      | Stage   | No. of copies | Submission Schedule /Remarks   |
|------|---|---------------|--|
| i)   | Initial Submission<br>Drawings, Data sheets, Type test Reports and O & M Instructions<br>(in case of standard products) | 5             | As per agreed schedule   |
| ii)  | Resubmission, if required   | 5             | Within 3 (three) weeks from date of comments including both ways postal time   |
| iii) | Approval or comments  |               | Within 3(three) weeks of receipt of resubmission.  |
| iv)  | Furnishing of distribution copies of drawings in bound volume   | See remark    | 2 Weeks from the date of final approval<br>Five (5) copies for each substation plus two (2) copies for corporate centre. |
| v)   | Furnishing of distribution copies of type test reports in bound volumes   | See remark    | 2 Weeks from the date of final approval<br>One (1) copies for each substation plus two (2) copies for corporate centre.  |
| vi)  | Furnishing of distribution copies of Routine test reports   | See remark    | 2 Weeks from the date of final approval<br>One (2) copies for each substation  |
| vii) | Furnishing of instruction/ operation manuals  | See remark    | As per agreed schedule<br>Four (4) copies for each substation plus three (3) copies for corporate centre.                |
| xi)  | CD-ROM/ Optical Disc of all 'As - built drawings/ design documents  | See remark    | on completion of works<br>one (1) set for each substation plus two (2) set for corporate centre.                         |

#### NOTES:

- a) The contractor may note that all re-submissions must incorporate all comments given in the prior submission by the Purchaser. Adequate justification for not incorporating the same must be submitted, failing which the submitted documents may be returned.
- b) The drawings, which are required to be frequently referred during execution, should be submitted on cloth lined paper. The list of such drawings shall be finalised with the Contractor at the time of Award.
- c) All major drawings shall be submitted in Auto Card Version 12 or better.
- d) The instruction Manuals shall contain full detailed drawings of all equipment being supplied under this contract, their exploded views with complete instructions for storage, handling, erection, commissioning, testing, operation, trouble shooting, servicing and overhauling procedures.
- e) If after the commissioning and initial operation of the installation, the instruction manuals require any modifications/ additions/ changes, the same shall be incorporated and the Contractor shall submit the updated final instruction manuals to the Purchaser.
- f) The Contractor shall furnish to the Purchaser, spare parts catalogues also.

### 3.6 COLOUR SCHEME

All steel structures, plates, etc. shall be painted with non-corrosive paint on a suitable primer. It may be noted that normally all Purchaser's electrical equipment in Purchaser's switchyard are painted with shade 697 of IS 5. All the indoor cubicles shall be of same colour scheme. For other miscellaneous items, the Purchaser will approve colour scheme.

### 3.7 PROVISIONS FOR EXPOSURE TO HOT AND HUMID CLIMATE

Outdoor equipment supplied under the specification shall be suitable for service and storage under tropical conditions of high temperature, high humidity' heavy rainfall and environment favourable to the growth of fungi and mildew. The indoor equipment located in non-air-conditioned areas shall also be of same type.

One or more adequately rated thermostatically controlled heaters, suitable for continuous operation at 240-V supply, shall be provided to maintain temperature so as to prevent condensation in any compartment. On-off switch and fuse shall also be provided. The surface temperature of the heater assembly shall be restricted to a value which will not shorten the life of the heater sheaths or the wire insulation or other components in the compartment. The heaters shall be installed in the compartment and electrical connections shall be made sufficiently away from the heaters to minimize deterioration of supply wire insulation. The heaters shall be designed to prevent any contact between the heater wire and air. The design and construction of the heater shall be to approval.

Besides the space heaters, special moisture and fungus resistant varnish may be applied to parts, which may be subjected to or predisposed to the formation of fungi due to presence or deposit of nutrient substances. The varnish shall not be applied to any surface or part where the treatment will interfere with the operation or the performance of the equipment.

The compartments may be provided with ventilation openings, if required. These openings shall be covered with fine wire mesh of brass to prevent ingress of insects and minimise the entry of dirt and dust. Openings in outdoor equipment shall be provided with shutter type blinds.

The degree of protection shall be in accordance with IS 13947 (Part-1) / IEC-947 (Part-1). Type test report for degree of protection test, on each type of the box shall be submitted for approval.

The minimum requirements for panels are as follows:

- a) Installed out door: IP- 55
- b) Installed indoors in air-conditioned area: IP-31
- c) Installed in covered area: IP-52
- d) Installed indoors in non air-conditioned area where possibility of entry of water is limited: IP-41.
- e) For LT Switchgear (AC & DC distribution Boards): IP-52.

### 3.8 RATING PLATES, NAME PLATES AND LABELS

Each main and auxiliary item of substation shall have, permanently attached to it in a conspicuous position, a rating plate of non-corrosive material. Upon this plate, shall be engraved manufacturer's name, year of manufacture, equipment name, type or serial number together with details of the loading conditions under which the item in question has been designed to operate, and such diagram plates as may be required by the Purchaser. The rating plate shall be according to IEC recommendations.

All such nameplates, instruction plates, rating plates shall be bilingual with Hindi inscription first followed by English. Alternatively two separate plates, one with Hindi and the other with English inscription, may be provided.

### 3.9 QUALITY ASSURANCE PROGRAMME

To ensure that the equipment and services under the scope of this Contract, whether manufactured or performed within the Contractor's Works or at his Sub-contractor's premises or at the Purchaser's site or at any other place of Work, are in accordance with the specifications, the Contractor shall adopt a suitable quality assurance programme to control such activities at all points, as necessary. Such programme shall be outlined by the Contractor and shall be finally accepted by the Purchaser after discussions before the award of Contract. A quality assurance programme of the contractor shall generally cover the following:

- (a) Contractor's organisation structure for the management and implementation of the proposed quality assurance programme;
- (b) Documentation control system;
- (c) Qualification data of bidder's key personnel;
- (d) The procedure for purchases of materials, parts components and selection of sub-Contractor's services including vendor analysis, source inspection, incoming raw material inspection, verification of material purchases etc.
- (e) System for shop manufacturing and site erection controls including process controls and fabrication and assembly control;
- (f) Control of non-conforming items and system for corrective actions;
- (g) Inspection and test procedure both for manufacture and field activities;
- (h) Control of calibration and testing of measuring instruments and field activities;
- (i) System for indication and appraisal of inspection status;
- (j) System for quality audits;
- (k) System for authorising release of manufactured product to the Purchaser
- (l) System for maintenance of records;
- (m) System for handling storage and delivery; and
- (n) A quality plan detailing out the specific quality control measures and Procedures adopted for controlling the quality characteristics relevant to each item of equipment furnished and/or services rendered.

The Purchaser or his duly authorised representative reserves the right to carry out quality audit and quality surveillance of the system and Procedure of the Contractor/'his vendors quality management and control activities.

On completion of erection of the equipment and before charging, each item of the equipment shall be thoroughly cleaned and then inspected jointly by the Purchaser and the Contractor for correctness and completeness of installation and acceptability for charging, leading to initial pre-commissioning tests at Site. The list of pre-commissioning tests to be performed shall be included in the Contractor's quality assurance programme.

### 3.10 Quality Assurance Documents

The Contractor shall be required to submit the following Quality Assurance Documents within three weeks after despatch of the equipment.

All Non - Destructive Examination Procedures, stress relief and weld repair. Procedure actually used during fabrication and reports including radiography interpretation reports.

Welder and welding operator qualification certificates Welder's identification list, listing welder's qualification procedure and welding identification symbols.

Raw material test reports on components as specified by the specification and/or agreed to in the quality plan.

Stress relief time temperature charts/oil impregnation time temperature charts

Factory test results for testing required as per applicable codes/mutually agreed quality plan/standards referred in the technical specification.

The quality plan with verification of various customer inspection points (CIP) as mutually agreed and methods used to verify the inspection and testing points in the quality plan were performed satisfactorily.

### 3.11 INSPECTION, TESTING & INSPECTION CERTIFICATE

The Purchaser, his duly authorised representative and/or outside inspection agency acting on behalf of the Purchaser shall have at all reasonable times free access to the Contractor's premises or Works and shall have the power, at all reasonable times to inspect and examine the materials and workmanship of the Works during its manufacture or erection if part of the Works is being manufactured or assembled at other premises or works, the Contractor shall obtain for the Engineer and for his duly authorised representative permission to inspect as if the works were manufactured or assembled on the Contractor's own premises or works. Inspection may be made at any stage of manufacture, despatch or at site at the option of the Purchaser and the equipment if found unsatisfactory due to bad workmanship or quality, material is liable to be rejected.

The reports for all type tests and additional type tests as per technical specification and shall be furnished by the Contractor along with equipment/material drawings. The type tests conducted earlier should have either been conducted in accredited laboratory (accredited based on ISO/IEC Guide 25/17025 or EN 45001 by the national accreditation body of the country where laboratory is located) or witnessed by the representative(s) of BSPGCL or Utility. The test-reports submitted shall be of the tests conducted within last 5 (five) years prior to the date of bid opening i.e. 24.09.2013. In case the test reports are of the test conducted earlier than 5 (five) years prior to the date of bid opening, the contractor shall repeat these test(s) at no extra cost to the purchaser.

In the event of any discrepancy in the test reports i.e. any test report not acceptable due to any design/manufacturing changes (including substitution of components) or due to non-compliance with the requirement stipulated in the technical specification or any/all additional type tests not carried out without any additional cost implication to the Purchaser.

The purchaser intends to repeat the type tests and additional type tests on transformers, reactors, cables and battery chargers for which test charges shall be payable as per provision of contract. The price of conducting type tests and additional type tests shall be included in Bid price and break up of these shall be given in the relevant schedule of Bid Proposal sheets. These type tests charges would be considered in bid evaluation. In case the bidder does not indicate charges for any of the type tests or does not mention the name of any test in the price schedules, it will be presumed that the particular test has been offered free of charge. Further, in case any bidder indicates that he shall not carry out a particular test, his offer shall be considered incomplete and shall be liable to be rejected.

All equipment being supplied shall conform to type tests and shall be subject to routine tests in accordance with requirements stipulated under respective sections. Purchaser reserves the right to witness any or all the type tests. The Contractor shall intimate the Purchaser the detailed programme about the tests at least three (3) weeks in advance in case of domestic supplies & six (6) weeks in advance in case of foreign supplies. Purchaser reserves the option for getting any or all the type tests repeated on the equipment. The Contractor shall also submit type test procedure for approval of the Purchaser.

The Contractor shall give the Purchaser/inspector thirty (30) days written notice of any material being ready for testing. Such tests shall be to the Contractor's account except for the expenses of the inspector. Unless witnessing of the tests is virtually waived, the Purchaser/ inspector will attend such tests within thirty (30) days of the date of which the equipment is notified as being ready for test/

inspection, failing which the Contractor may proceed with the test which shall be deemed to have been made in the Inspector's presence and the Contractor shall forthwith forward duly certified copies of test reports in triplicate to the Inspector.

The Purchaser or Inspector shall, within fifteen (15) days from the date of inspection as defined herein, give notice in writing to the Contractor, of any objection to any drawings and all or any equipment and workmanship which in his opinion is not in accordance with the Contract. The Contractor shall give due consideration to such objections and shall either make the modifications that may be necessary to meet the said objections or shall confirm in writing to the Purchaser/ inspector giving reasons therein, that no modifications are necessary to comply with the Contract.

When the factory tests have been completed at the Contractor's or Sub-Contractor's works, the Purchaser/ inspector shall issue a certificate to this effect within fifteen (15) days after completion of tests but if the tests are not witnessed by the Purchaser/inspector, the certificate shall be issued within fifteen (15) days of receipt of the Contractor's Test certificate by the Engineer/ Inspector. Failure of the Purchaser/inspector to issue such a certificate shall not prevent the Contractor from proceeding with the Works. The completion of these tests or the issue of the certificate shall not bind the Purchaser to accept the equipment should it, on further tests/ after erection, be found not to comply with the Contract. The equipment shall be dispatched to site only after approval of test reports and issuance of MICC by the Purchaser.

In all cases where the Contract provides for tests whether at the premises or at the works of the Contractor or of any Sub-Contractor, the Contractor except where otherwise specified shall provide free of charge such items as labour, materials, electricity, fuel, water, stores, apparatus and instruments as may be reasonably demanded by the Purchaser /Inspector or his authorised representative to carry out effectively such tests of the equipment in accordance with the Contract and shall give facilities to the Purchaser Inspector or to his authorised representative to accomplish testing.

The inspection by Purchaser and issue of Inspection Certificate thereon shall in no way limit the liabilities and responsibilities of the Contractor in respect of the agreed quality assurance programme forming a part of the Contract.

The Purchaser will have the right of having at his own expenses any other test(s) of reasonable nature carded out at Contractor's premises or at site or in any other place in addition of aforesaid type and routine tests, to satisfy that the material comply with the specification.

The Purchaser reserves the right for getting any field tests not specified in respective sections of the technical specification conducted on the completely assembled equipment at site. The testing equipment for these tests shall be provided by the Purchaser

### 3.12 FINISHING OF METAL SURFACES

All metal surfaces shall be subjected to treatment for anti-corrosion protection. All ferrous surfaces for external use unless otherwise stated elsewhere in the specification or specifically agreed, shall be hot-dip galvanized after fabrication. High tensile steel nuts & bolts and spring washers shall be electro-galvanized to service condition 4. All steel conductors including those used for earthing/ grounding (above ground level) shall also be galvanized according to IS: 2629.

#### 3.12.1 HOT DIP GALVANISING

The minimum weight of the zinc coating shall be 610 g/ m<sup>2</sup> and minimum thickness of coating shall be 85 microns for all items thicker than 6mm. For items lower than 6mm thickness requirement of coating

thickness shall be as per relevant ASTM. For surface which shall be embedded in concrete, the zinc coating shall not be less than 610 g/ m<sup>2</sup>.

The galvanised surfaces shall consist of a continuous and uniform thick coating of zinc, firmly adhering to the surface of steel. The finished surface shall be clean and smooth and shall be free from defects like discoloured patches, bare spots, unevenness of coating, spelter which is loosely attached to the steel globules, spiky deposits, blistered surface, flaking or peeling off, etc. The presence of any of these defects noticed on visual or microscopic inspection shall render the material liable to rejection.

After galvanizing no drilling or welding shall be performed on the galvanized parts of the equipment excepting that nuts may be threaded after galvanizing. Sodium dichromate treatment shall be provided to avoid formation of white rust after hot dip galvanisation. The galvanized steel shall be subjected to six one-minute dips in copper sulphate solution as per IS-2633.

Sharp edges with radii less than 2.5 mm shall be able to withstand four immersions of the Standard Preece test. All other coatings shall withstand six immersions.

Following galvanizing tests shall essentially be performed as per relevant Indian Standards.

- Coating thickness
- Uniformity of zinc
- Adhesion test
- Mass of zinc coating

Galvanised material must be transported properly to ensure that galvanised surfaces are not damaged during transit. Application of zinc rich paint at site shall not be allowed.

### 3.12.2 PAINTING

All sheet steelwork shall be degreased, pickled, phosphated in accordance with the IS-6005 "Code of practice for phosphating iron and sheet". All surfaces, which will not be easily accessible after shop assembly, shall beforehand be treated and protected for the life of the equipment. The surfaces, which are to be finished painted after installation or require corrosion protection until installation, shall be shop painted with at least two coats of primer. Oil, grease, dirt and swarf shall be thoroughly removed by emulsion cleaning. Rust and scale shall be removed by pickling with dilute acid followed by washing with running water, rinsing with slightly alkaline hot water and drying.

After phosphating, thorough rinsing shall be carried out with clean water followed by final rinsing with dilute dichromate solution and oven drying. The phosphate coating shall be sealed with application of two coats of ready mixed, stoving-type zinc chromate primer. The first coat may be 'flash dried' while the second coat shall be stoved.

After application of the primer, two coats of finishing synthetic enamel paint shall be applied, each coat followed by stoving. The second finishing coat shall be applied after inspection of first coat of painting.

The exterior colour of the paint shall be as per shade no. 697 of IS -5 and inside shall be glossy white. Each coat of primer and finishing paint shall be of slightly different shade to enable inspection of the painting. A small quantity of finishing paint shall be supplied for minor touching up required at site after installation of the equipment.

In case the Bidder proposes to follow his own standard surface finish and protection procedures or any other established painting procedures, like electrostatic painting etc., the procedure shall be submitted along with the Bids for Purchaser's review & approval.

### 3.13 AUXILIARY SUPPLY

The sub-station auxiliary supply is normally met through a system indicated under section-5 having the following parameters. The auxiliary power for station supply, including the equipment drive, cooling system of any equipment, air-conditioning, lighting etc shall be designed for the specified Parameters as under. The DC supply for the instrumentation and PLCC system shall also conform to the parameters as indicated in the following.

| <i>Normal Voltage</i> | <i>Variation in Voltage</i> | <i>Frequency<br/>HZ</i> | <i>in Phases</i> | <i>Neutral<br/>connection</i> |
|-----------------------|-----------------------------|-------------------------|------------------|-------------------------------|
| 415V                  | +/- 1 0%                    | 50 +/- 5%               | 3/4-Wire         | Solidly                       |
| 240 V                 | +/- 1 0%                    | 50 +/- 5%               | 1 /2-wire        | Earthed.                      |
| 220V                  | 240-190 V                   | DC                      | 2-wire           | Isolated                      |
| 50 V                  | 53- 41.5 V                  | DC                      | 2-wire           | +ve -earthed                  |

Combined variation of voltage and frequency shall be limited to +/- 10%.

### 3.14 CONTROL CABINETS, JUNCTION BOXES, TERMINAL BOXES & MARSHALLING BOXES FOR OUTDOOR EQUIPMENT

All types of boxes, cabinets, etc. shall generally conform to & be tested in accordance with IS-5039/ IS 8623, IEC: 439, as applicable, and the clauses given below:

Control cabinets, junction boxes, Marshalling boxes and terminal boxes shall be made of sheet steel or aluminium enclosure and shall be dust, water and vermin proof. Sheet steel used shall be at least 2.0-mm thick cold rolled or 2.5 mm hot rolled. The box shall be properly braced to prevent wobbling. There shall be sufficient reinforcement to provide level surfaces, resistance to vibrations and rigidity during transportation and installation. In case of aluminium enclosed box the thickness of aluminium shall be such that it provides adequate rigidity and long life as comparable with sheet steel of specified thickness.

Cabinet/boxes shall be free-standing, floor-mounting type, wall mounting type or pedestal mounting type as per requirements. Cabinet/boxes shall be provided with double hinged doors with padlocking arrangements. The distance between two hinges shall be adequate to ensure uniform sealing pressure against atmosphere. The quality of the gasket shall be such that it does not get damaged/cracked during the operation of the equipment.

All doors, removable covers and plates shall be gasketed all around with suitably profiled EPDM gaskets. The gasket shall be tested in accordance with approved quality plan. The quality of gasket shall be such that it does not get damaged/cracked during the ten years of operation of the equipment or its major overhaul whichever is earlier. All gasketed surfaces shall be smooth straight and reinforced if necessary to minimise distortion and to make a tight seal. Ventilating Louvers, if provided, shall have screen and filters. The screen shall be fine wire mesh made of brass.

All boxes/cabinets shall be designed for the entry of cables from bottom by means of weather proof and dust-proof connections. Boxes and cabinets shall be designed with generous clearances to avoid interference between the wiring entering from below and any terminal blocks or accessories mounted within the box or cabinet. Suitable cable gland plate projecting at least 150 mm above the base of the marshalling kiosk/box shall be provided for this purpose along with the proper blanking plates. Necessary number of cable glands shall be supplied and fitted on this gland plate. The gland shall project at least 25mm above gland plate to prevent entry of moisture in cable crutch. Gland plate shall have provision for some future glands to be provided later, if required. The Nickel- plated glands shall be dust-proof, screw on & double compression type and made of brass. The gland shall have provision

for securing armour of the cable separately and shall be provided with earthing tag. The glands shall conform to BS: 6121.

A 240-V, single phase, 50 Hz, 15-A AC plug and socket shall be provided in the cabinet with ON-OFF switch for connection of hand lamps. Plug and socket shall be of industrial grade. For illumination, 20-W fluorescent tube or a 15-W CFL shall be provided. The switching of the fittings shall be controlled by a door switch.

All control switches shall be of rotary switch type and Toggle/piano switches shall not be accepted.

Positive earthing of the cabinet shall be ensured by providing two separate earthing pads. The earth wire shall be terminated on to the earthing pad and secured by the use of self-etching washer. Earthing of hinged door shall be done by using a separate earth wire.

The bay marshalling kiosks shall be provided with danger plate and a diagram showing the numbering/connection/ferruling by pasting the same on the inside of the door.

#### Tests

- a) In addition to routine tests as per IS 5039, following routine tests shall also be conducted:
  - i) Check for wiring
  - ii) Visual and dimension check
- b) The enclosure of bay marshalling kiosk, junction box, terminal box shall be type tested for IP-55 as per IS: 13947. After IP-55 test, 2.5 kV rms for 1 (one) minute, insulation resistance and functional tests shall be carried out.

A canopy and sealing arrangements for operating rods shall be provided in Marshalling Boxes control cubicles to prevent ingress of rain water.

### 3.15 AUXILIARY SWITCHES

The auxiliary switches shall conform to following type tests:

- (a) Electrical endurance test - A minimum of 2000 operations for 2 A DC with a time constant greater than or equal to 20 millisecond with a subsequent examination of mV drop/visual defects/temperature rise test.
- (b) Mechanical endurance test. A minimum of 1, 00,000 operations with a subsequent checking of contact pressure test/ visual examination.
- (c) Heat run test on contacts.  
Insulation Resistance Test/HV test (2.5 kV for one minute)

### 3.16 TERMINAL BLOCKS AND WIRING

Control and instrument leads from the switchboards or from other equipment will be brought to terminal boxes or control cabinets in conduits. All inter-phase and external connections to equipment or to control cubicles will be made through terminal blocks.

Terminal blocks shall be 1100-V grade and have continuous rating to carry the maximum expected current on the terminals. Those shall be of moulded piece, complete with insulated barriers stud type terminals, washers, nuts and lock nuts. Screw clamp, overall insulated, insertion type, rail mounted 'terminals can be used in place of stud type terminals. But preferably the terminal blocks shall be non-disconnecting stud type equivalent to Elmex type CATM4, Phoenix, cage-clamp-type of Wago or equivalent.

### 3.17 FIRST FILL OF CONSUMABLES, OIL AND LUBRICANTS



All the first fill of consumables such as oils, lubricants, filling compounds, touch up paints, soldering/brazing material for all copper piping of circuit breakers and essential chemicals etc. which will be required to put the equipment covered under the scope of the specifications, into successful Operation, shall be furnished by the Contractor unless specifically excluded under the exclusions in these specifications and documents.

### 3.18 PACKAGING & PROTECTION

All the equipments shall be suitably protected, coated, covered or boxed and crated to prevent damage or deterioration during transit, handling and storage at Site till the time of erection. On request of the Owner / Purchaser, the supplier shall also submit packing details/associated drawing for any equipment/material under his scope of supply, to facilitate the Purchaser to repack any equipment/material at a later date, in case the need arises. While packing all the materials, the limitation from the point of view of availability of Railway wagon sizes in India should be taken into account. The supplier shall be responsible for any loss or damage during transportation, handling and storage due to improper packing. Any demurrage, wharfage and other such charges claimed by the transporters, railways etc. shall be to the account of the supplier.

All coated surfaces shall be protected against abrasion, impact, discolouration and any other damages. All exposed threaded portions shall be suitably protected with either a metallic or a non-metallic protecting device. All ends of all valves and pipings and conduit equipment connections shall be properly sealed with suitable devices to protect them from damage.

### 3.19 TESTING AND COMMISSIONING

An indicative list of tests is given below. Supplier shall perform any additional test based on specialities of the items as per the filed O.P./Instructions of the driven equipment supplier or Owner / purchaser without any extra cost to the owner / Purchaser. The supplier shall arrange all instruments required for conducting these tests alongwith calibration certificates and shall furnish the list of instruments to the Owner / Purchaser for approval.

Insulation resistance.

Phase sequence and proper direction of rotation.

Any motor operating incorrectly shall be checked to determine the cause and the conditions corrected.

## SECTION 4

### GUARANTEED TECHNICAL PARTICULARS

#### LIST OF TECHNICAL DATASHEETS

In this section Technical Datasheets (TDS) of various equipment/items and system drawings that are required to be referred is furnished herewith. List of datasheets/drawings and numbers to be accorded is also given below.

1. FIRE WATER PIPING FOR HYDRANT SYSTEM, ISOMETRIC LAYOUT & HYDRAULIC CALC.  
**DRG. NO. TB-DRG-374-552-02**
2. FIRE ALARM AND EXTINGUISHER LAYOUT FOR BAY CONTROL ROOM  
**DRG. NO. TB-DRG-374-552-03**
3. FIRE PROTECTION & DETECTION SYSTEM DATA SHEET  
**DRG. NO. TB-DS-374-552-01**

**SECTION- 5**

**ENCLOSURES TO SPECIFICATION**

**SCHEDULES TO BE FILLED UP BY THE BIDDER**

- Schedule 1 **Schedule of Deviations**
- Schedule 2 **Schedule of past experience and qualifying requirements**
- Schedule 3 **Details of contact persons (technical & commercial)**
- Schedule 4 **Enclosures to Specification**
  - a. **ANNEXURE-A Drawings**

## SCHEDULE-1

### SCHEDULE OF TECHNICAL DEVIATION

The following are the deviations / variations / exceptions from the specification:

---

| Section | Clause No./<br>Page No. | Statement of deviation/<br>Variations/Exceptions |
|---------|-------------------------|--|
|---------|-------------------------|--|

---

- 
- 1) In case, this schedule is not submitted, it will be presumed that the equipment /material to be supplied under this contract is deemed to be in compliance with the specification.
  - 2) If there is NIL deviation, even then the format to be filled as **NIL DEVIATION**
  - 3) Continuation sheets of like size and format may be used as per the Bidder's Requirement and shall be annexed to this schedule.

Place

Signature of the authorized representative of Bidder

Name -----

Date

Designation-----

Company seal-----

## SCHEDULE – 2

### SCHEDULE OF PAST EXPERIENCE AND QUALIFYING REQUIREMENT

Following is the list of earlier orders executed by us for supply of equipment / material of Similar nature over the last past five years:

| S.No. | Item | Brief rating | Qty | customer | Date<br>of order | Date<br>of supply | Order<br>value |
|-------|------|--------------|-----|----------|------------------|-------------------|----------------|
|-------|------|--------------|-----|----------|------------------|-------------------|----------------|

Place

Signature of the authorized representative of Bidder

Date

Name-----

Designation-----

Company seal -----

Note: Continuation sheets of like size and format may be used as per the Bidder's Requirement and shall be annexed to this schedule.

**SCHEDULE-3**

**DETAILS OF CONTACT PERSON BOTH TECHNICAL AND COMMERCIAL**

Name

Address for correspondence

Phone No.

Fax No.

Email

Place

Signature of the authorized representative of Bidder

Date

Name-----

Designation-----

Company seal -----

Note: Continuation sheets of like size and format may be used as per the Bidder's Requirement and shall be annexed to this schedule.

## SCHEDULE – 4

### ENCLOSURES TO SPECIFICATION

(ANNEXURE-A)

#### **DRAWINGS:**

1. LAYOUT PLAN FOR 220/132 KV SWITCHYARD  
**DRG. NO. TB-0-374-510-026 R0**
2. FIRE WATER PIPING FOR HYDRANT SYSTEM, ISOMETRIC LAYOUT & HYDRAULIC CALC.  
**DRG. NO. TB-DRG-374-552-02**
3. FIRE ALARM AND EXTINGUISHER LAYOUT FOR BAY CONTROL ROOM  
**DRG. NO. TB-DRG-374-552-03**
4. FIRE PROTECTION & DETECTION SYSTEM DATA SHEET  
**DRG. NO. TB-DS-374-552-01**

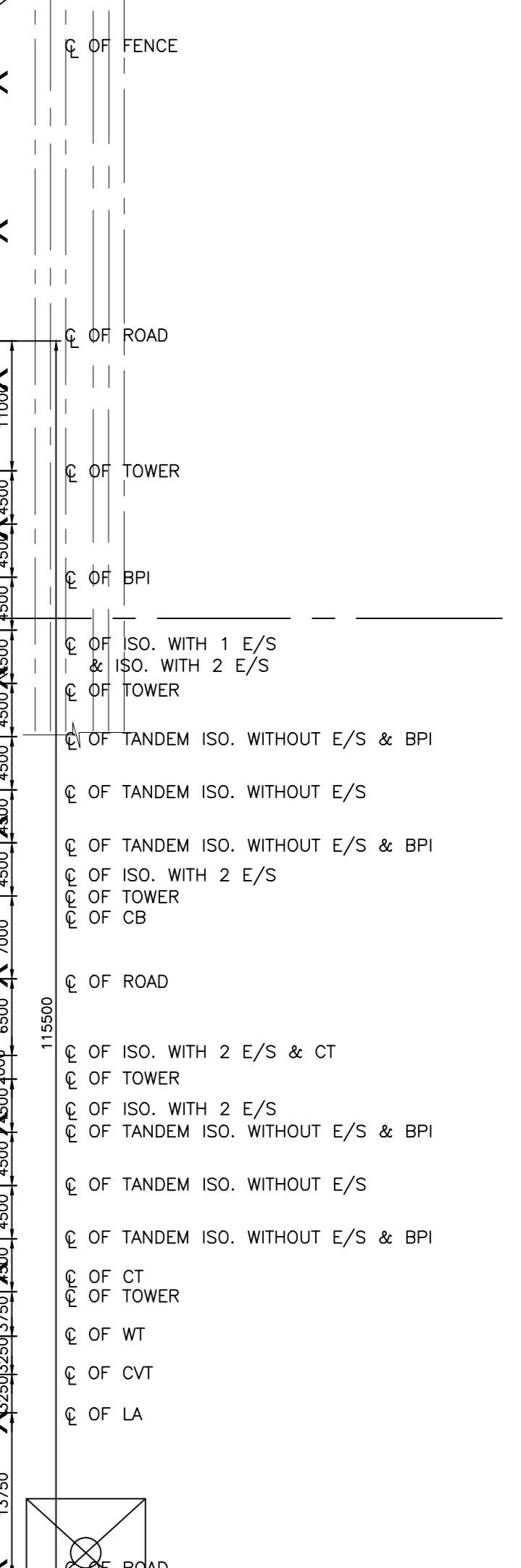
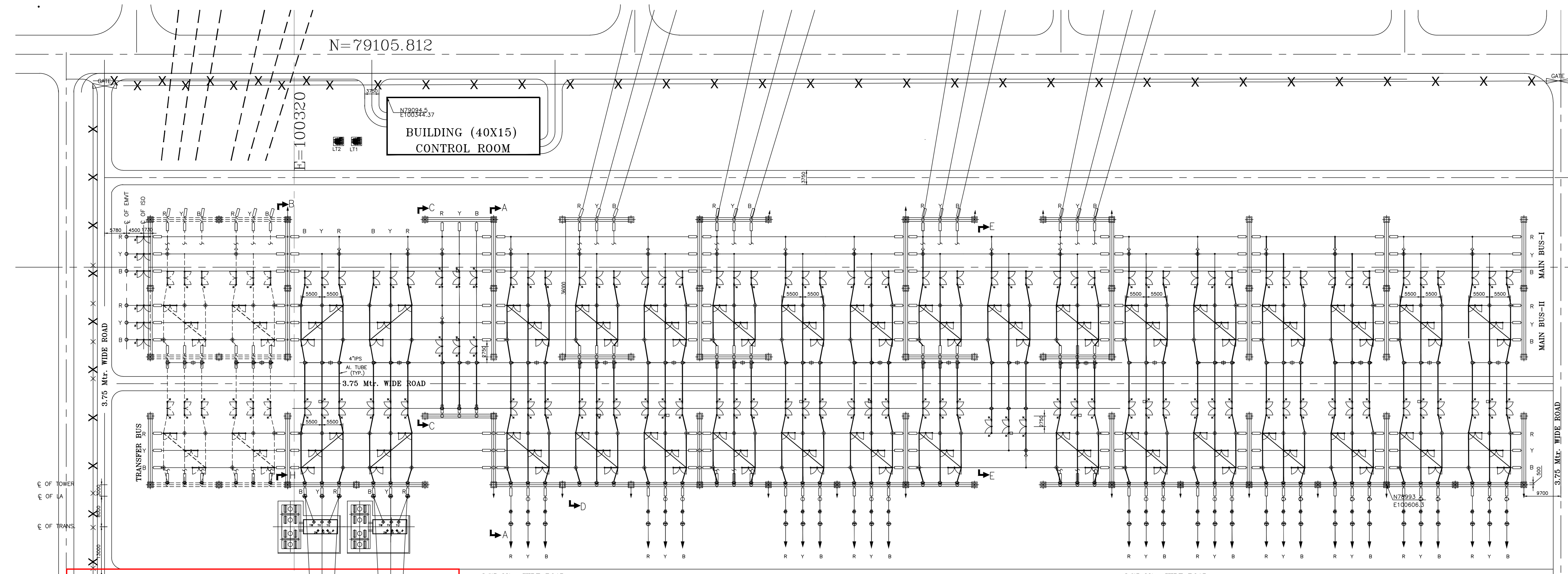
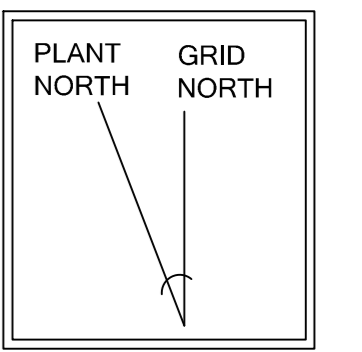

**BILL OF MATERIAL (OLD SCOPE)**

| S.N. | EQUIPMENT DESCRIPTION  | KV      | SYMBOL | TOTAL QTY. |
|------|--|---------|--------|------------|
| 1A.  | SF6 CIRCUIT BREAKER (3-PH), 1600A  | 245     |        | 13         |
| 1B.  | SF6 CIRCUIT BREAKER (3-PH), 3150A-(BC BAY)                                       | 245     |        | 01         |
| 2A.  | HCB ISOLATOR WITH 2 E/S 3#, 1600A (MECHANICALLY GANGED)                          | 245     |        | 13         |
| 2B.  | HCB ISOLATOR WITH 2 E/S 3#, 3150A (MECHANICALLY GANGED)-BC BAY                   | 245     |        | 02         |
| 3.   | HCB ISOLATOR WITH 1 E/S 3#, 1600A (MECHANICALLY GANGED)                          | 245     |        | 15         |
| 4.   | HCB ISOLATOR WITHOUT E/S 3#, 1600A, TANDEM TYPE (MECHANICALLY GANGED)            | 245     |        | 25         |
| 5A.  | CURRENT TRANSFORMER, 1600 (1-PH), 5 CORE (EXTENDED CURRENT RATING 120%)          | 245     |        | 39         |
| 5B.  | CURRENT TRANSFORMER, 2400 (1-PH), 5 CORE (EXTENDED CURRENT RATING 120%) - BC BAY | 245     |        | 03         |
| 6.   | 198kV SURGE ARRESTOR (1-PH)  | 198     |        | 36         |
| 7.   | WAVE TRAP (1-PH), 1250A, 0.5 mH  | 245     |        | 12         |
| 8.   | 4400pF CAPACITOR VOLTAGE TRANSFORMER (1-PH)                                      | 245     |        | 18         |
| 9.   | EMVT (1-PH)  | 245     |        | 06         |
| 10.  | BUS POST INSULATOR   | 245     |        | 91         |
| 11.  | 220/132kV, 150MVA ICT  | 220/132 |        | 02         |
| 12.  | 120kV SURGE ARRESTOR (1-PH)  | 120     |        | 06         |

**BILL OF MATERIAL (NEW SCOPE)**

| S.N. | EQUIPMENT DESCRIPTION   | KV  | SYMBOL | TOTAL QTY. |
|------|---|-----|--------|------------|
| 1.   | 220 kV, 1600A SF6 CIRCUIT BREAKER (3-PH)  | 245 |        | 04         |
| 2.   | HCB ISOLATOR WITH 2 E/S 3#, 1600A (MECHANICALLY GANGED)   | 245 |        | 04         |
| 3.   | HCB ISOLATOR WITH 1 E/S 3#, 1600A (MECHANICALLY GANGED)   | 245 |        | 04         |
| 4.   | HCB ISOLATOR WITHOUT E/S 3#, 1600A, TANDEM TYPE (MECHANICALLY GANGED)   | 245 |        | 08         |
| 5.   | CURRENT TRANSFORMER, 1600 (1-PH), 5 CORE (EXTENDED CURRENT RATING 120%)   | 245 |        | 12         |
| 6.   | 198kV SURGE ARRESTOR (1-PH)   | 198 |        | 12         |
| 7.   | WAVE TRAP (1-PH), 1600A, 0.5 mH   | 245 |        | 08         |
| 8.   | 4400pF CAPACITOR VOLTAGE TRANSFORMER (1-PH)   | 245 |        | 12         |
| 9.   | BUS POST INSULATOR  | 245 |        | 28         |
| 10.  | 145kV, 1250A 3-PHASE, SPRING OPERATED SF6 CIRCUIT BREAKERS SUITABLE FOR 3-PHASE OPERATION.                        | 145 |        | 06         |
| 11.  | 145kV, 1250A 3-PHASE, DOUBLE BREAK ISOLATOR (MECHANICALLY GANGED MOTOR OPERATED) WITH TWO E/S (MANUALLY OPERATED) | 145 |        | 07         |
| 12.  | 145kV, 1250A 3-PHASE, DOUBLE BREAK ISOLATOR (MECHANICALLY GANGED MOTOR OPERATED) WITH ONE E/S (MANUALLY OPERATED) | 145 |        | 05         |
| 13.  | 145kV, 1250A 3-PHASE, DOUBLE BREAK ISOLATOR (MECHANICALLY GANGED MOTOR OPERATED) WITHOUT E/S                      | 145 |        | 05         |
| 14.  | 145kV, 1-PHASE 5 CORE CURRENT TRANSFORMER   | 145 |        | 18         |
| 15.  | 145kV, 8800 pF, 110 / 0.110 / 0.110 / 0.110, 1-PHASE CAPACITOR VOLTAGE TRANSFORMER                                | 145 |        | 12         |
| 16.  | 120kV, 1-PHASE SURGE ARRESTERS, 10KA, CLASS-3   | 145 |        | 09         |
| 17.  | 145kV, 1250A, 0.5mH, 1-PHASE WAVE TRAP  | 145 |        | 01         |
| 18.  | 145kV, 1-PHASE BUS POST INSULATOR   | 145 |        | 20         |

**CLEARANCE TABLE :-**

|   | 220kV  | 132kV  |
|---|--------|--------|
| MINIMUM CLEARANCE TABLE   |        |        |
| PHASE TO PHASE (PP)   | 2100mm | 1300mm |
| PHASE TO EARTH (PE)   | 2100mm | 1300mm |
| SECTION CLEARANCE (SC)  | 5000mm | 3800mm |
| HEIGHT OF TUBE CENTRE LINE OF FIRST LEVEL FROM PLINTH LEVEL                                       | 5500mm | 4600mm |
| GROUND CLEARANCE TO NEAREST PART NOT AT EARTH POTENTIAL OF AN INSULATOR SUPPORTING LIVE CONDUCTOR | 2550mm | 2550mm |

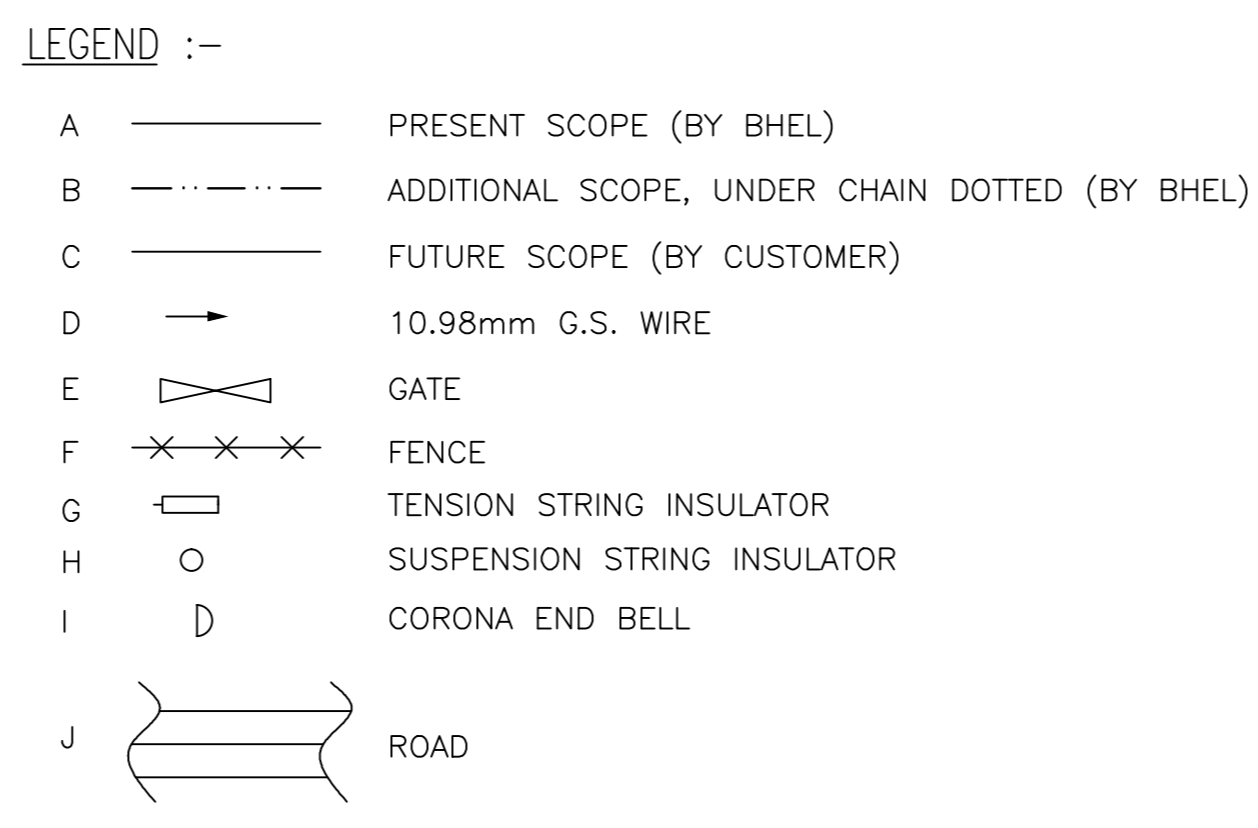

**NOTE :-**

- ALL DIMENSIONS ARE IN MM UNLESS OTHERWISE SPECIFIED.
- SYSTEM PARAMETERS

| S. NOS. | DESCRIPTION                         | UNIT  | 220  | 132  |
|---------|-------------------------------------|-------|------|------|
| 1.      | NOMINAL SYSTEM VOLTAGE              | kV    | 220  | 132  |
| 2.      | HIGHEST SYSTEM VOLTAGE              | kV    | 245  | 145  |
| 3.      | BASIC IMPULSE LEVEL                 | kVp   | 1050 | 650  |
| 4.      | POWER FREQUENCY WITHSTAND           | kVrms | 460  | 275  |
| 5.      | SWITCHING IMPULSE WITHSTAND VOLTAGE | kVrms | NA   | NA   |
| 6.      | CREEPAGE DISTANCE (MINIMUM)         | mm/kV | 25   | 25   |
| 7.      | SYSTEM FAULT LEVEL FOR 1 SEC        | KA    | 40   | 31.5 |

**3. CONDUCTOR DETAIL**

| S. NOS. | DESCRIPTION               | 220  | 132                    |
|---------|---------------------------|--|------------------------|
| 1.      | MAIN BUS                  | QUAD MOOSE ACSR  | TWIN MOOSE ACSR        |
| 2.      | EQUIPMENT INTERCONNECTION | 4"IPS AL TUBE/TWIN MOOSE ACSR (OD=114.30mm ID=97.18mm) | SINGLE/TWIN MOOSE ACSR |
| 4.      | JUMPER /DROPPERS          | TWIN MOOSE ACSR  | SINGLE/TWIN MOOSE ACSR |
| 5.      | SHIELD WIRE               | 7/5.66 GALVANISED STEEL (10.98mm DIA)                  |                        |

4. ALL THE BUS BARS, STRING BUSSES & EQUIPMENTS ARE PROTECTED FROM 7/3.66 GALVANISED STEEL WIRE.  
 5. DURING ERECTION 3 NOS. FOUNDATION FOR WAVE TRAP IN EACH FEEDER BAY OF 220KV AND 132KV SWITCHYARD TO BE CASTED. ONLY 2 NOS. WAVE TRAP IN 220 kv 1 NO. IN 132 kv PER FEEDER BAY WILL BE UTILISED DURING COMMISSIONING AS PER PLOC REQUIREMENT AND AFTER NECESSARY TESTING.  
 6. SURVEY AND STROING OF LINE CONDUCTOR, SHIELD WIRE, INSULATOR AND HARDWARE BETWEEN DEAD END TOWER AND SUBSTATION TERMINAL GANTRY ARE NOT IN BHEL SCOPE. HOWEVER, JUMPING FOR THE RESPECTIVE EQUIPMENT & SHIELDING REQUIREMENT FOR PROTECTION OF LIVE EQUIPMENT AND JUMPERS SHALL BE IN BHEL SCOPE.  
 7. ALL EQUIPMENT STRUCTURE (EXCEPT CIRCUIT BREAKER) ARE PIPE TYPE.  
 8. SCOPE : AS FOLLOWS:  
 (a) OLD SCOPE : BAYS INSIDE CHAIN DOTTED LINE.  
 (b) NEW SCOPE : BAYS OUTSIDE CHAIN DOTTED LINE.

| REV. | DATE | ALTERED CHECKED APPROVED | REV. | DATE | ALTERED CHECKED APPROVED | REV. | DATE | ALTERED CHECKED APPROVED | REV. | DATE | ALTERED CHECKED APPROVED | REV. | DATE | ALTERED CHECKED APPROVED | REV. | DATE | ALTERED CHECKED APPROVED | REV. | DATE | ALTERED CHECKED APPROVED | REV. | DATE | ALTERED CHECKED APPROVED |  |
|------|------|--------------------------|------|------|--------------------------|------|------|--------------------------|------|------|--------------------------|------|------|--------------------------|------|------|--------------------------|------|------|--------------------------|------|------|--------------------------|--|
|      |      |                          |      |      |                          |      |      |                          |      |      |                          |      |      |                          |      |      |                          |      |      |                          |      |      |                          |  |

|                              |  |
|------------------------------|--|
| NAME OF CUSTOMER             | BIHAR STATE POWER GENERATION COMPANY LIMITED               |
| NAME OF CONSULTANT           | STEAG ENERGY SERVICES (INDIA) PVT. LTD.                    |
| JOB NO. - 374                | xzkgd@fj;kstuk dk uke                                      |
| STATUS OF DRAWING - CONTRACT | NAME OF PROJECT<br>2 X 250MW BARAUNI THERMAL POWER STATION |
| DISTRIBUTION OF PRINTS       |  |
| SCALE                        | 1 : 450  |
| TITLE                        | LAYOUT PLAN FOR 220/132 KV SWITCHYARD                      |
| DRAWING NO.                  | TB-0-374-510-002   |
| SHEET NO.                    | 01   |



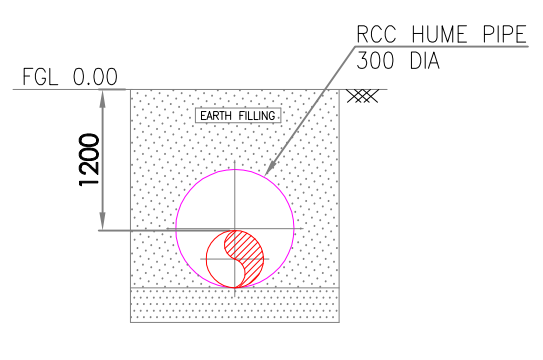
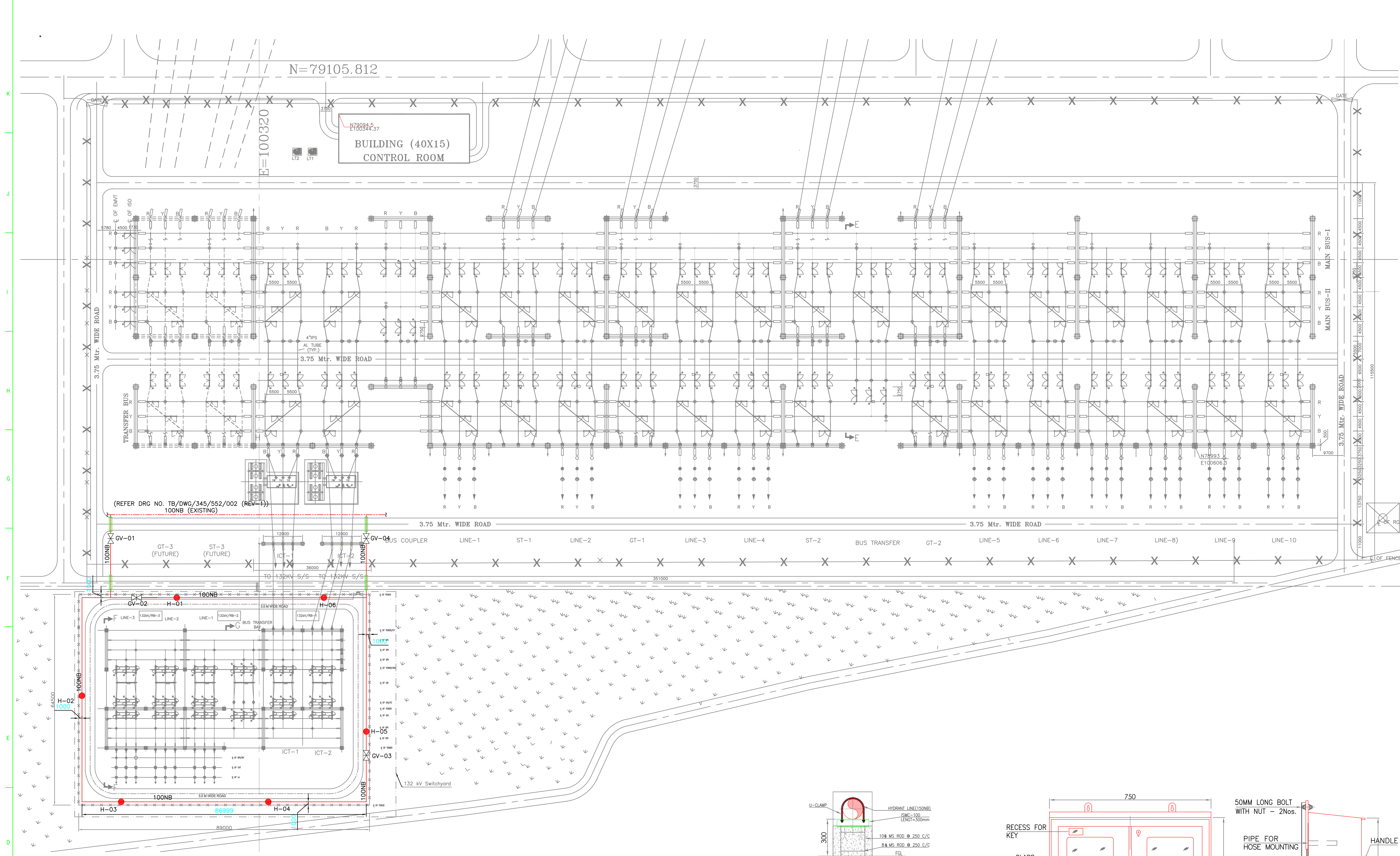

SECTION B-B

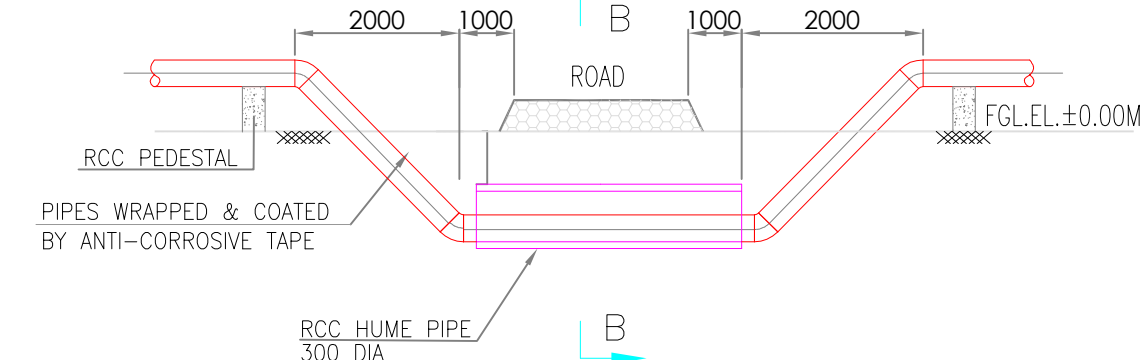

TYPICAL DETAIL OF PIPING AT ROAD CROSSING

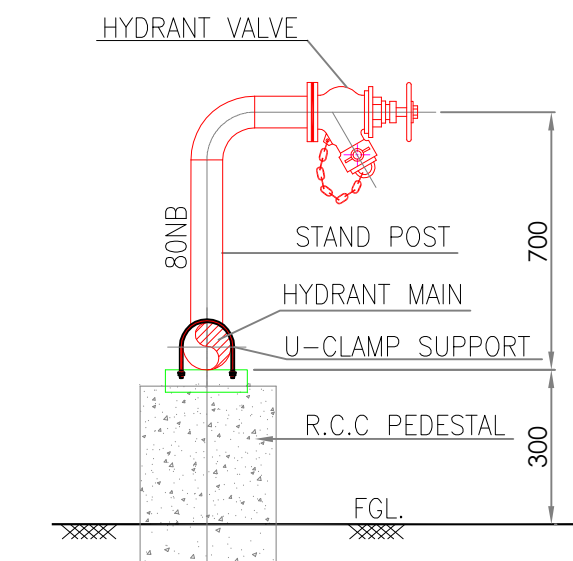

TYPICAL DETAIL FOR SINGLE HEADED HYDRANT  
(HYDRANT TAPPING FROM ABOVE GROUND MAIN)

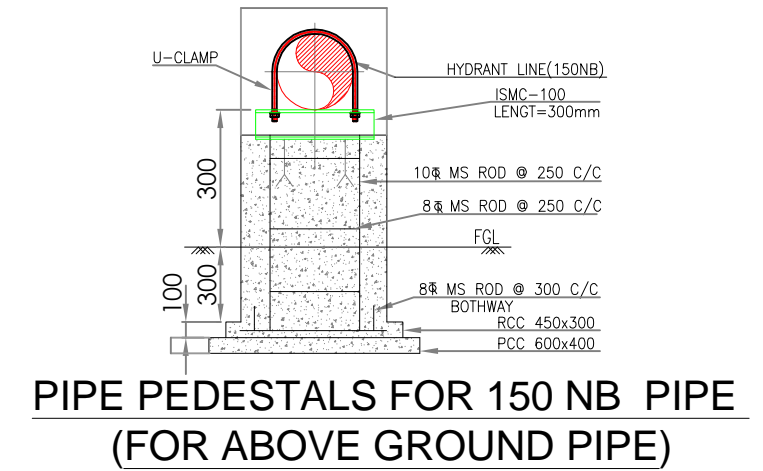

PIPE PEDESTALS FOR 150 NB PIPE  
(FOR ABOVE GROUND PIPE)

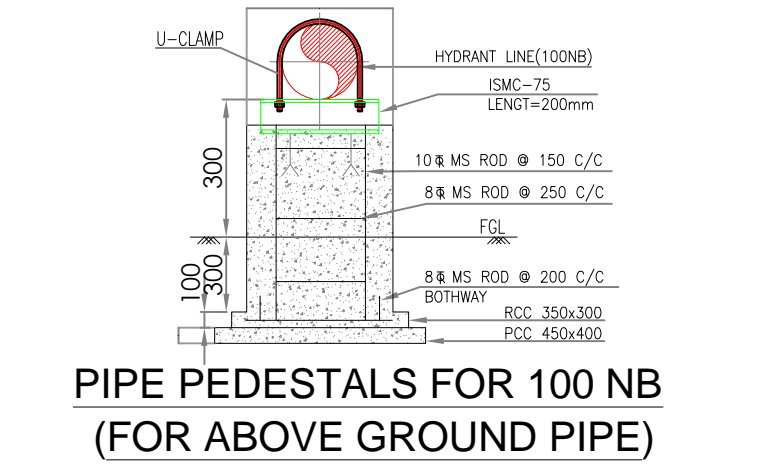

PIPE PEDESTALS FOR 100 NB PIPE  
(FOR ABOVE GROUND PIPE)

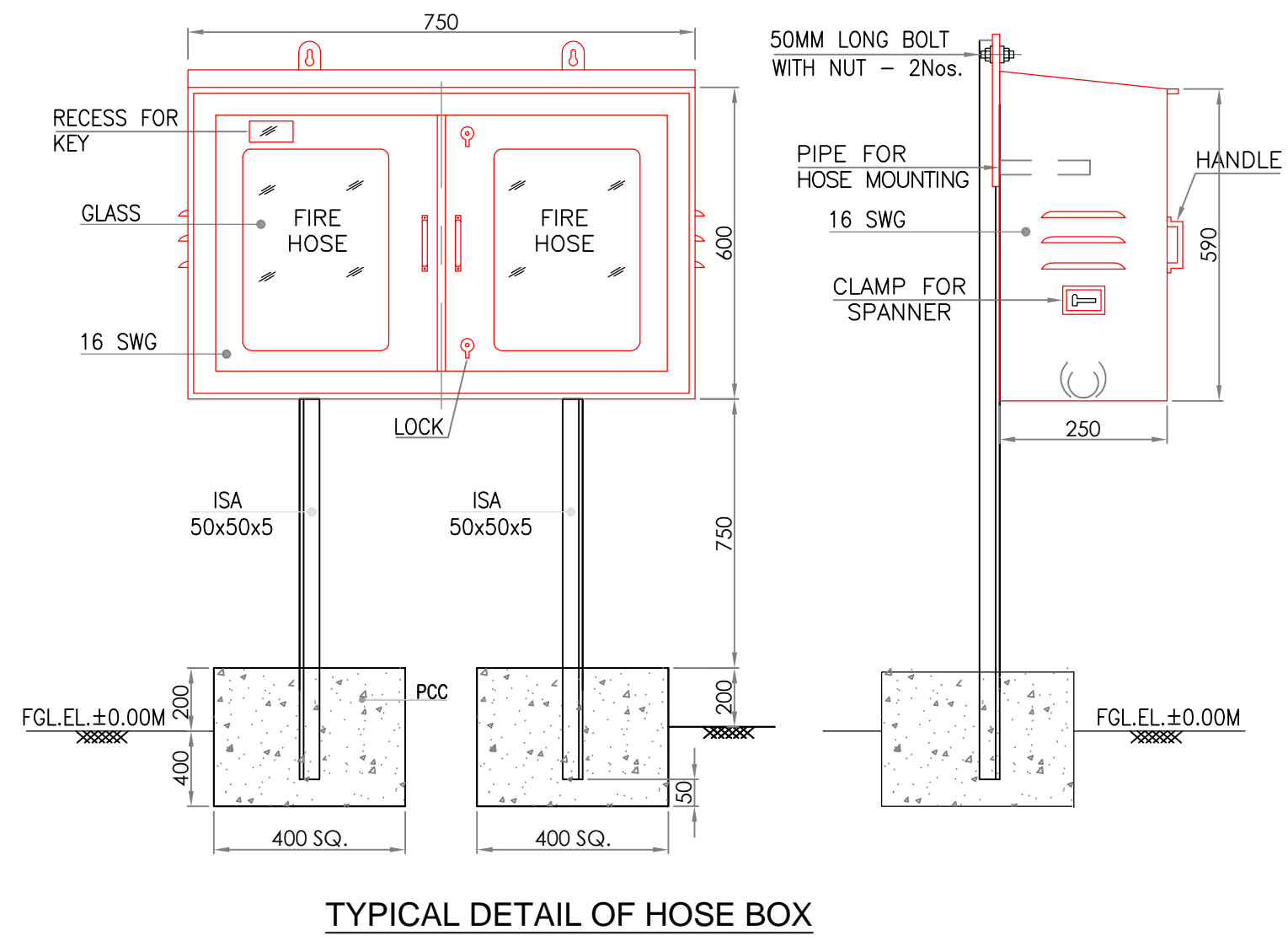

TYPICAL DETAIL OF HOSE BOX

|            |  |       |                                       |
|------------|--|-------|---------------------------------------|
| DRG. NO.   | TB-0-374-510-002   | TITLE | LAYOUT PLAN FOR 220/132 KV SWITCHYARD |
| PROJECT    | 2 X 250MW BARAUNI THERMAL POWER STATION                      |       |                                       |
| CONSULTANT | STEAG ENERGY SERVICES (INDIA) PVT. LTD.                      |       |                                       |
| PURCHASER  | BHARAT HEAVY ELECTRICALS LTD. TRANSMISSION PROJECTS DIVISION |       |                                       |
| TITLE      | PIPING LAYOUT FOR HYDRANT SYSTEM                             |       |                                       |

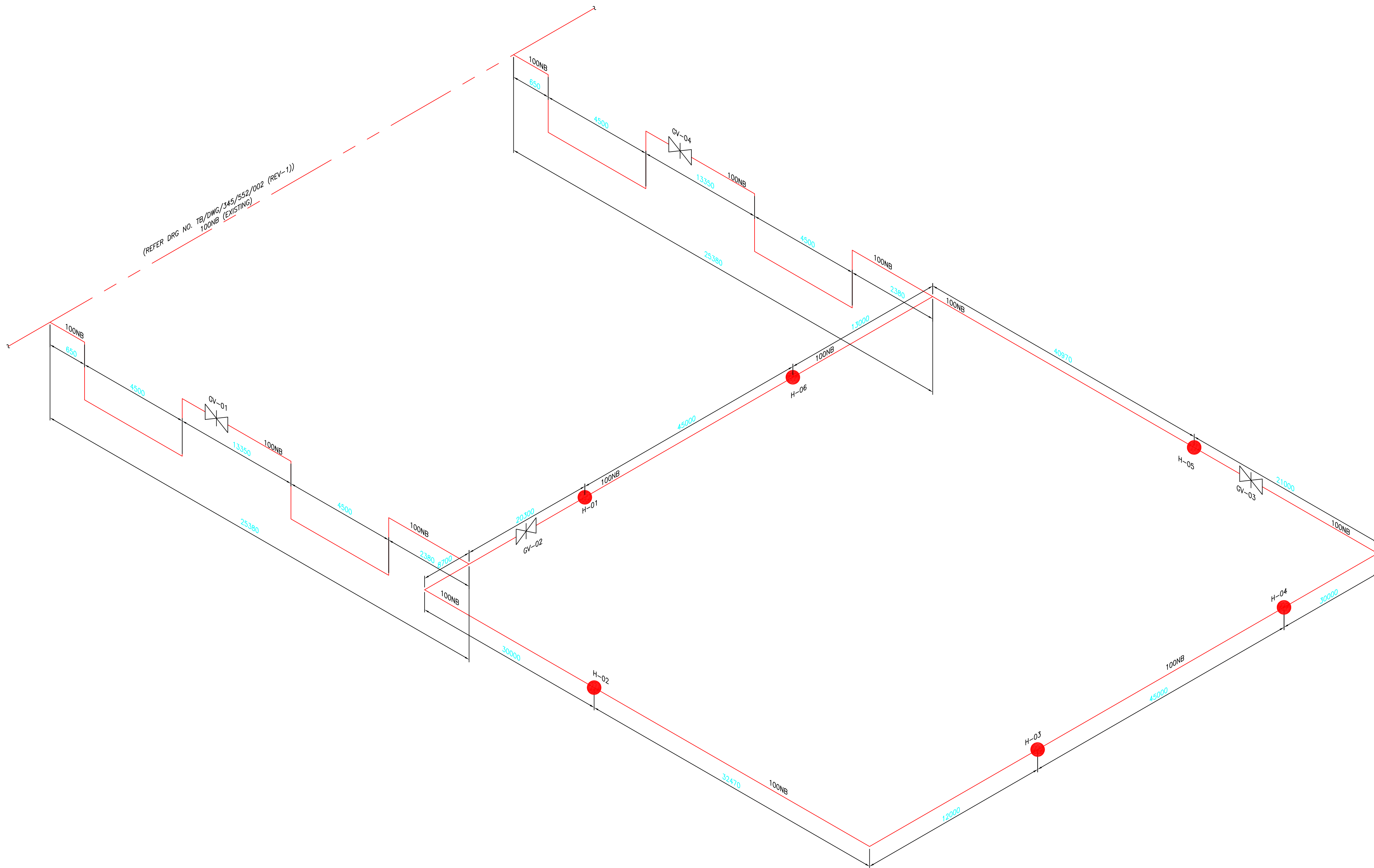

ISOMETRIC LAYOUT FOR HYDRANT SYSTEM

**LEGEND**

| SYMBOL | DESCRIPTION   | SYMBOL | DESCRIPTION                  |
|--------|---------------|--------|------------------------------|
|        | PROPOSED PIPE |        | GATE VALVE (ISOLATION VALVE) |
|        | EXISTING PIPE |        | REDUCER                      |
|        | YARD HYDRANT  |        | HUME PIPE FOR ROAD CROSSING  |

**BILL OF MATERIAL**

| SR.NO. | NAME          | SIZE  | MOC  | DESCRIPTION | QTY.      |
|--------|---------------|-------|------|-------------|-----------|
| 1      | PIPE          | 100NB | M.S. | IS:1239-(M) | 400 Mtrs. |
| 2      | PIPE          | 80NB  | M.S. | IS:1239-(M) | 12 Mtrs.  |
| 3      | HYDRANT VALVE | 80NB  | G.M. | --          | 6 Nos.    |
| 4      | GATE VALVE    | 100NB | C.I. | --          | 4 Nos.    |

| REV.NO.                   | DESCRIPTION                             | DRAWN | CHECK | APPD. |
|---------------------------|---|-------|-------|-------|
| <b>REFERENCE DRAWINGS</b> |   |       |       |       |
| DRG. NO.                  | TITLE                                   |       |       |       |
| TB-D-374-510-002          | LAYOUT PLAN FOR 220/132 KV SWITCHYARD   |       |       |       |
| TB-DRG-374-552-02         | PIPING LAYOUT FOR HYDRANT SYSTEM        |       |       |       |
| PROJECT                   | 2 X 250MW BARAUNI THERMAL POWER STATION |       |       |       |

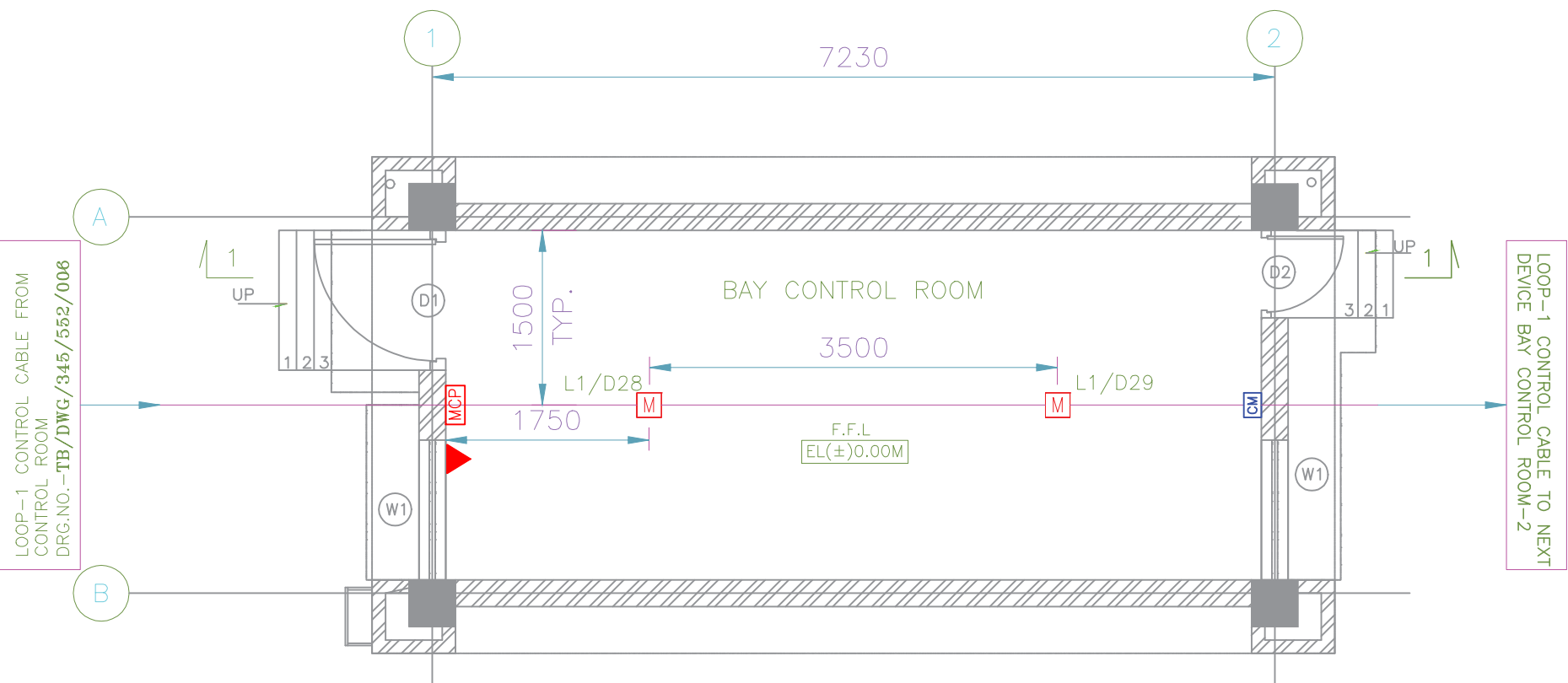

FLOOR PLAN AT EL(±)0.00M  
BAY CONTROL ROOM-1

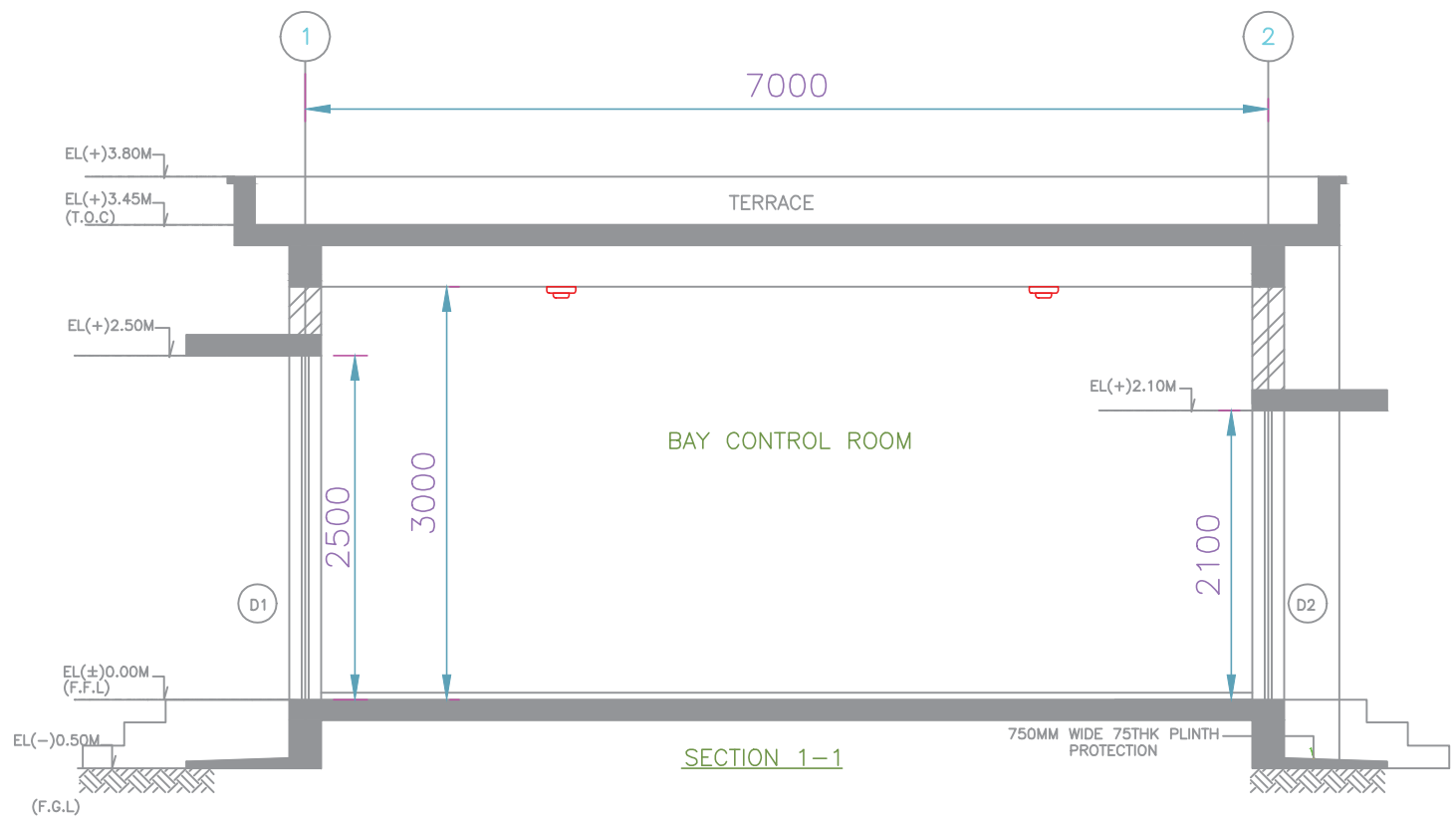

SECTION 1-1

|  |   |
|--|---|
| PROJECT :  | <b>132 KV BARAUNI SWITCHYARD EXTN. AT BARAUNI TPS</b> |
|  |   |
| CLIENT :   | <b>BHARAT HEAVY ELECTRICALS LIMITED</b>               |
|  |   |

|  |
|--|
| <b>FIRE PROTECTION &amp; DETECTION SYSTEM DATA SHEET</b> |
|--|

| INDEX |   |              |
|-------|---|--------------|
| S.NO. | ITEM DESCRIPTION                          | NO. OF PAGES |
| 1     | Data Sheet of pipe                        | 3            |
| 2     | Data Sheet of Single headed hydrant valve | 2            |
| 3     | Data Sheet of branch pipe with nozzle     | 2            |
| 4     | Data Sheet of RRL hose                    | 5            |
| 5     | Data Sheet of Hose Box                    | 2            |
| 6     | Data sheet of Portable fire Extinguisher  | 2            |
| 7     | Data Sheet of gate valve                  | 2            |
| 8     | Data Sheet of MCP                         | 3            |
| 9     | Data Sheet of Multi sensor detector       | 3            |
| 10    | Data sheet of Control Module              | 3            |

## TECHNICAL DATA SHEET FOR PIPE

| S. No. | DESCRIPTION  | SPECIFICATION   |
|--------|--|---|
| 1.0.0  | <b><u>UNDERGROUND M. S. PIPING<br/>(BURIED)</u></b>          |   |
| 1.1.0  | Manufacturer   | JINDAL / SURYA ROSHNI/GOOD LUCK   |
| 1.2.0  | Size / OD Max. X Thickness (mm)                              | a) 25 NB – IS: 1239, Part – I (Medium) b) 50 NB – IS: 1239, Part – I (Medium) c) 65 NB – IS: 1239, Part – I (Medium) d) 80 NB – IS: 1239, Part – I (Medium) e) 100 NB – IS: 1239, Part – I (Medium) f) 150 NB – IS: 1239, Part – I (Medium) g) 200 NB – Thick 5.20, IS: 3589 ERW h) 250 NB – Thick 5.20, IS: 3589 ERW |
| 2.0.0  | <b>ABOVE GROUND M.S. PIPING<br/>(NORMALLY FULL OF WATER)</b> |   |
| 2.1.0  | Manufacturer   | JINDAL / SURYA ROSHNI/GOOD LUCK   |
| 2.2.0  | Size / OD Max. X Thickness (mm)                              | a) 25 NB – IS: 1239, Part – I (Medium) b) 50 NB – IS: 1239, Part – I (Medium) c) 65 NB – IS: 1239, Part – I (Medium) d) 80 NB – IS: 1239, Part – I (Medium) e) 100 NB – IS: 1239, Part – I (Medium) f) 150 NB – IS: 1239, Part – I (Medium) i) 200 NB – Thick 5.20, IS: 3589 ERW                                      |

|       |  |  |
|-------|--|--|
| 3.0.0 | <p>ABOVEGROUND G.I. PIPING<br/> <b>(Normally empty but periodic charge of water and for detection line for HVW spray system)</b></p> | j) 250 NB – Thick 5.20, IS: 3589 ERW   |
| 3.1.0 | Manufacturer   | JINDAL / SURYA ROSHNI/GOOD LUCK  |
| 3.2.0 | Size / OD Max. X Thickness (mm)  | <p>a) 25 NB –IS: 1239, Part – I (Medium) b) 32 NB –IS: 1239, Part – I (Medium) c) 40 NB –IS: 1239, Part – I (Medium) d) 50 NB –IS: 1239, Part – I (Medium) e) 65 NB –IS: 1239, Part – I (Medium) f) 80 NB –IS: 1239, Part – I (Medium) g) 100 NB –IS: 1239, Part – I (Medium) h) 150 NB –IS: 1239, Part – I (Medium)</p> |
| 4.0.0 | <p>PYLON M.S. PIPING</p>   |  |
| 4.1.0 | Manufacturer   | JINDAL / SURYA ROSHNI/GOOD LUCK  |
| 4.2.0 | <p>Size / OD Max. X Thickness (mm)<br/> . Certification</p>  | <p>a) 50 NB –IS: 1239, Part – I, Medium b) 65 NB –IS: 1239, Part – I, Medium</p>   |
| 5.0.0 |  | ISI Marked   |

|            |       |
|------------|-------|
| Contractor | BHEL. |
|------------|-------|

|         |  |         |                         |                       |                         |
|---------|--|---------|-------------------------|-----------------------|-------------------------|
| 1.0.0   | <b>PIPING</b>  |         |                         |                       |                         |
| 1.1.0   | Make : Jindal/Surya Roshni/Good Luck   |         |                         |                       |                         |
| 1.2.0   | Complete piping, fittings, counter-flanges and all other accessories furnished                                   |         |                         |                       |                         |
| 1.3.0 A | <b>OVER GROUND PIPES NORMALLY FULL OF WATER [M.S.]</b>   |         |                         |                       |                         |
|         | Sr. No.  | Size NB | OD Max x Thickness [mm] | Specification         | Estimated Length [M]    |
|         | 1  | 50      | 60.8 x 3.6              | IS 1239 Part-1 (Med.) | As per approved drawing |
|         | 2  | 80      | 89.5 x 4.0              | - do -                |                         |
|         | 3  | 100     | 115.0 x 4.5             | - do -                |                         |
|         | 4  | 150     | 166.5 x 4.8             | - do -                |                         |
|         | 5  | 200     | 219.1 x 5.0             | IS 3589 ERW GR 410    |                         |
|         | 6  | 250     | 273.0 x 5.0             | - do -                |                         |
|         | 7  | 300     | 323.9 x 5.0             | - do -                |                         |
| 1.3.0-B | <b>BURIED PIPES (M.S)</b>  |         |                         |                       |                         |
|         | Sr. NO.  | Size NB | OD Max x Thickness (mm) | Specification         | Estimated Length (M)    |
|         | 1  | 50      | 60.8 x 3.6              | IS 1239 Part-1 (Med)  | As per approved Drawing |
|         | 2  | 80      | 89.5 x 4.0              | - do -                |                         |
|         | 3  | 100     | 115.0 x 4.5             | - do -                |                         |
|         | 4  | 150     | 166.5 x 4.8             | - do -                |                         |
|         | 5  | 200     | 219.1 x 5.0             | IS 3589 GR 410        |                         |
|         | 6  | 250     | 273.0 x 5.0             | - do -                |                         |
|         | 7  | 300     | 323.9 x 5.0             | - do -                |                         |
| 1.3.0-C | <b>OVER GROUND PIPES NORMALLY EMPTY, BUT PERIODIC CHARGE OF WATER DETECTION LINE OF HVWS SYSTEM (GALVANISED)</b> |         |                         |                       |                         |
|         | Sr. No.  | Size NB | OD Max x Thickness (mm) | Specification         | Estimated Length (m)    |
|         | 1  | 25      | 34.2 x 3.2              | IS:1239 Part 1 (Med.) | As per approved Drawing |
|         | 2  | 32      | 42.9 x 3.2              | - do -                |                         |
|         | 3  | 40      | 48.8 x 3.2              | - do -                |                         |
|         | 4  | 50      | 60.8 x 3.6              | - do -                |                         |
|         | 5  | 65      | 76.6 x 3.6              | - do -                |                         |
|         | 6  | 80      | 89.5 x 4.0              | - do -                |                         |
|         | 7  | 100     | 115.0 x 4.5             | - do -                |                         |
|         | 8  | 150     | 166.5 x 4.8             | - do -                |                         |



## TECHNICAL DATA SHEET FOR HYDRANT VALVE

| <b>A. GENERAL</b>                        |  |
|--|--|
| 1. Manufacturer                          | New Age / Shahbhogilal   |
| 2. Specification                         | IS: 5290   |
| 3. Drawing No.                           | V132F62, Rev.0   |
| 4. Bonnet type                           | Screwed type 3" BSP  |
| 5. Flange Drilling Dimension             | O.D. , 190.5mm P.C.D. 152.4mm, 4 Holes Dia. 19mm   |
| 6. Inlet                                 | 80mm N.B.  |
| 7. Outlet                                | 63-mm female instantaneous coupling with spring lock type Lug as per IS:5290 Type A  |
| <b>B. MATERIAL OF CONSTRUCTION</b>       |  |
| 1. Body, Female Inst. Outlet, Bonnet.    | S.S.304 conf. to IS: 3444, Gr. I   |
| 2. Spindle                               | S.S conf. to IS:6603   |
| 3. Spring                                | S.S conf. to IS:6528   |
| 4. Hand wheel                            | Cast Iron conf. to IS: 210   |
| 5. Washer For Female Outlet, Seat washer | Rubber conf. to IS: 937  |
| 6. Gland packing                         | Asbestos conf. to IS: 4687   |
| 7. Blank Cap                             | ABS Plastic  |
| <b>C. TESTING &amp; QUALITY CONTROL</b>  |  |
| 1. Dimension Check                       | As per attached drawing  |
| 2. Water tightness test [seat test]      | 14 Bar   |
| 3. Hydrostatic pressure test [body test] | 21 Bar for 2.5 Minutes   |
| 4. Flow test                             | At 7 Bar 900LPM Min.   |
| 5. Documents                             | Internal Inspection Report, Material Test Certificate, Manufacturer's Test certificate   |
| <b>D. PAINTING/FINISHING</b>             |  |
|  | Valve will be painted with 2 coats of fire red paint shade Number 536 of IS: 5 over a coats of red oxide primer. The paint shall conform to IS: 2932. Hand wheel will be painted black |
| <b>E. MARKING</b>                        |  |
|  | Each Valve shall be permanently marked with  |
|  | 1. Manufacturer's name or trade mark   |
|  | 2. Year of manufacture   |
|  | 3. BIS mark with serial no.  |
|  | 4. TYPE  |

### REVISION STATUS

| DATE       | PREPARED BY | CHECKED BY | APPROVED BY | REV. | REMARK |
|------------|-------------|------------|-------------|------|--------|
| 05.01.2018 | AMAMUL      | ABID       | SARWER      | 0    |        |

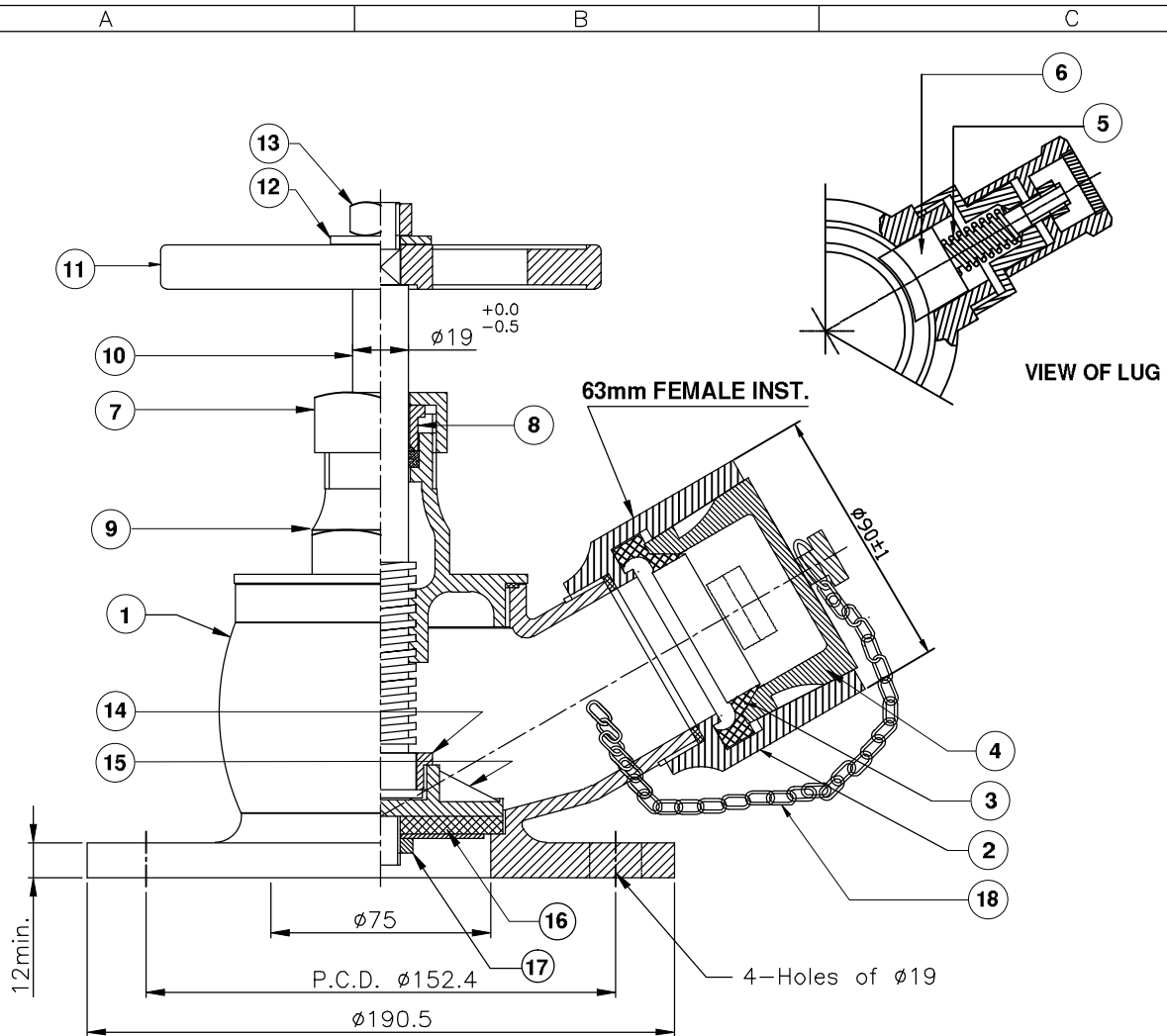

| 18  | CHAIN         | G.I.             | --            |
|-----|---------------|------------------|---------------|
| 17  | NUT           | S.S.             | --            |
| 16  | SEAT WASHER   | RUBBER           | IS:937        |
| 15  | SEAT VALVE    | S.S. 304         | IS:3444 Gr-I  |
| 14  | CHECK NUT     | S.S. 304         | IS:3444 Gr-I  |
| 13  | HEX.NUT       | M.S (GALVANIZED) | --            |
| 12  | WASHER        | M.S (GALVANIZED) | --            |
| 11  | HAND WHEEL    | C.I.             | IS:210        |
| 10  | SPINDLE       | S.S. 304         | IS:6603       |
| 9   | BONNET        | S.S. 304         | IS:3444 Gr-I  |
| 8   | GLAND BUSH    | S.S. 304         | IS:3444 Gr-I  |
| 7   | GLAND NUT     | S.S. 304         | IS:3444 Gr-I  |
| 6   | CAM TOOTH     | S.S. 304         | IS:3444 Gr-I  |
| 5   | SPRING        | S.S.             | IS:6528       |
| 4   | BLANK CAP     | ABS PLASTIC      | --            |
| 3   | OUTLET WASHER | RUBBER           | IS:937        |
| 2   | FEMALE OUTLET | S.S. 304         | IS:3444 Gr-I  |
| 1   | BODY          | S.S. 304         | IS:3444 Gr-I  |
| No. | DESCRIPTION   | MATERIAL         | SPECIFICATION |

**NOTES:-**

- \* HYDRANT VALVE AS PER IS:5290, Type-A
- \* PRESSURE TEST-
  - VALVE SEAT TIGHTNESS TEST AT 14 BAR SHALL NOT SHOW ANY SIGN OF LEAKAGE.
  - BODY TEST AT 21 BAR SHALL NOT SHOW ANY SIGN OF LEAKAGE.
- \* FLOW TEST-900 LPM minimum AT 7 BAR.
- \* VALVE SHALL BE PAINTED WITH TWO COATS OF FIRE RED PAINT SHADE NO.536 OF IS:5 OVER A COATS OF PRIMER. THE PAINT SHALL CONFORM TO IS:2932.
- \* TOLERANCES WHERE NOT SPECIFIED SHALL BE  $\pm 0.5$  MM.
- \* HYDRANT VALVES SHALL BE "BIS MARK".
- \* ALL DIMENSIONS ARE IN MM.

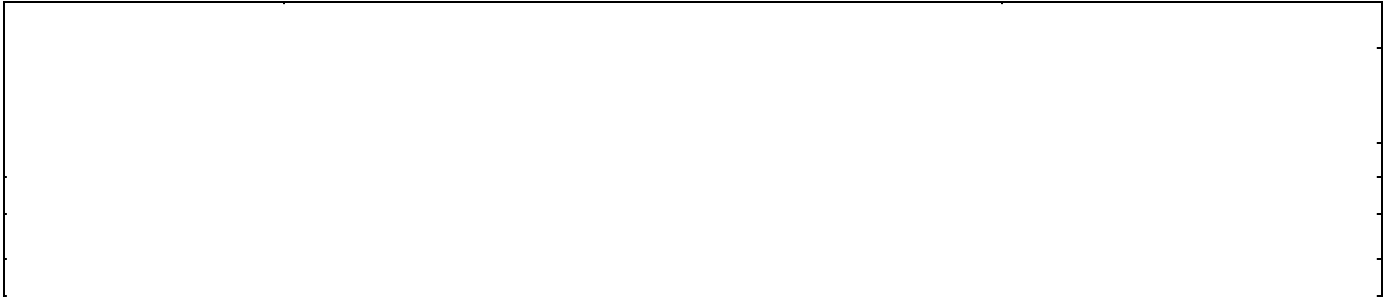

## TECHNICAL DATA SHEET FOR BRANCH PIPE WITH NOZZLE

| <b>A. GENERAL</b>                       |   |
|---|---|
| 1. Manufacturer                         | New Age / Shahbhogilal  |
| 2. Specification                        | IS:903  |
| 3. Inlet                                | 63 mm male instantaneous Inlet  |
| 4. Outlet                               | 15 mm bore jet nozzle   |
| <b>B. MATERIAL OF CONSTRUCTION</b>      |   |
| 1. Branch pipe                          | S.S. 304 conf. to IS : 3444 GR.I  |
| 2. Nozzle                               | S.S. 304 conf. to IS : 3444 GR.I  |
| 3. Washer                               | Rubber conf. to IS: 937 Type-B  |
| <b>C. TESTING &amp; QUALITY CONTROL</b> |   |
| 1. Dimension Check                      | As per attached drawing   |
| 2. Hydrostatic pressure test            | 21 Bar for 2.5 Minutes  |
| 3. Documents                            | Internal Inspection Report, Material Test Certificate, Manufacturer's Test certificate  |
| <b>D. MARKING</b>                       |   |
|   | Each branch pipe shall be clearly and permanently marked<br>i) BIS mark with serial no.<br>ii) Manufacturer's name or trademark<br>iii) Year of manufacture<br>iv) Size |
| <b>E. FINISHING</b>                     |   |
|   | Each Branch Pipe & Nozzle shall be polished.<br>Burrs and sharp edges shall be removed.   |



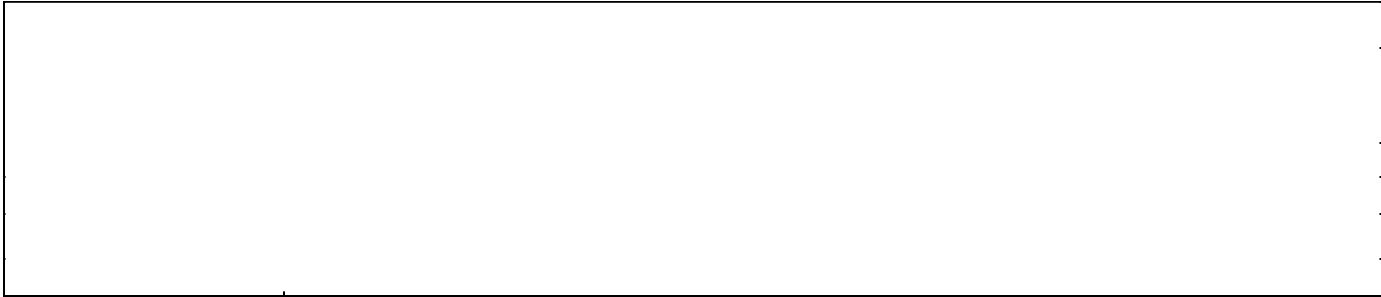

## TECHNICAL DATA SHEET FOR RRL HOSE WITH COUPLING

|                        |  |
|------------------------|--|
| Make                   | New Age / Shahbhogilal   |
| Type/Code              | Reinforced rubber line (RRL) as per IS 636 type A  |
| Application            | Hydrant System   |
| Size & Length          | 63 mm x 15 mts length  |
| Working Pressure       | 14 kg/cm <sup>2</sup>  |
| Test Pressure          | 22 kg/cm <sup>2</sup>  |
| Burst Pressure         | 38 kg/cm <sup>2</sup>  |
| End Fitting /Material  | Instantaneous spring Lock type male/female coupling of SS 304 construction at both sides to IS:903 |
| Mass of hose per meter | 425 gm/m   |
| Approval               | TAC  |
| GA Drawing             | Enclosed   |

# FIRE CHIEF

RUBBERISED FABRIC REINFORCED RUBBER LINED FIRE HOSE



## NEWAGE



IS : 636 : 88



# FIRE CHIEF

RUBBERISED  
FABRIC  
REINFORCED  
RUBBER LINING  
MAKES  
**FIRE CHIEF**  
THE MOST  
DESIRED  
FIRE HOSE

*The jacket is woven on a circular hose weaving loom using carefully selected and tested synthetic yarn.*

*The lining is prepared separately by coating both sides of a strong fabric with specially compounded latex rubber and then vulcanised.*

*The edges of this flat lining are overlapped and joined together lengthwise to form a tubing.*

*This tubing forms the lining. It is coated with an adhesive, inserted into the jacket and bonded to it under steam pressure.*

*Thus FIRE CHIEF is a hose within a hose and meets the requirements of tests laid down for type-A fire hose in IS:636-88.*



IS : 636 : 88



TYPE : A

On completion of 110 cycles of the abrasion testing machine, the jacket of hose with plain rubber lining is worn out and fails at 7kg/cm<sup>2</sup>.

RRL holds on and carries this pressure for a further 90 cycles.

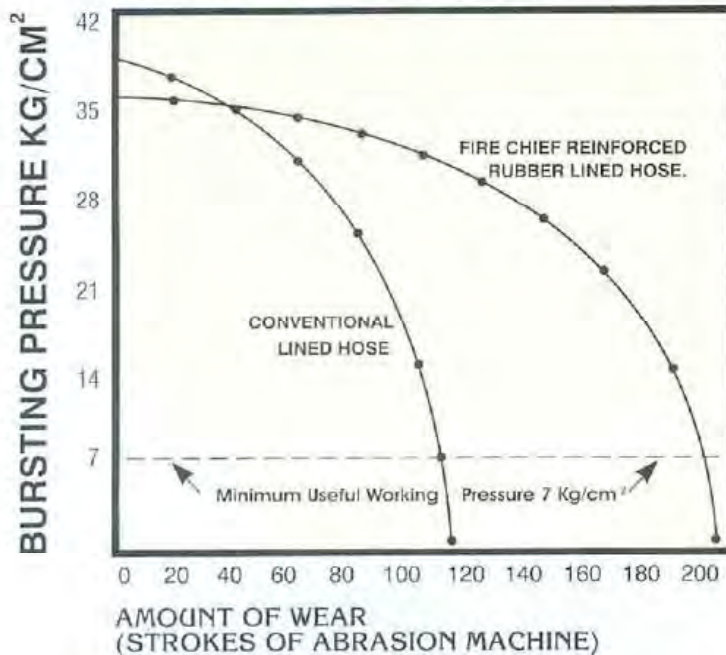

Rubber lined hose, worn out at a little over 100 strokes of the abrasion machine, fails at 7 kg/cm<sup>2</sup>, whereas RRL hose carries this pressure for a further 90 strokes of the abrasion machine.

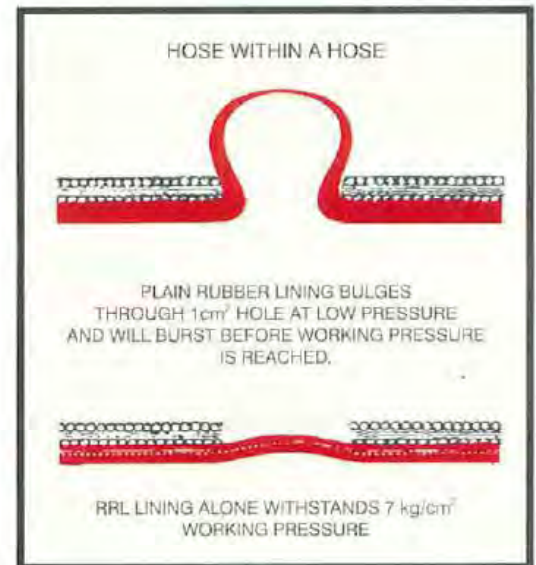

At the one square centimeter cut (opening) in the jacket, the rubberised fabric lining is supported by the jacket, and is able to withstand 7 kg/cm<sup>2</sup> working pressure.

| SPECIFICATION                         |     |     |     |     |
|---------------------------------------|-----|-----|-----|-----|
| Diameter : mm.                        | 38  | 50  | 63  | 70  |
| Burst Pressure : kg/cm <sup>2</sup>   | 40  | 40  | 40  | 40  |
| Proof Pressure : kg/cm <sup>2</sup>   | 22  | 22  | 22  | 22  |
| Kink Pressure : kg/cm <sup>2</sup>    | 22  | 22  | 22  | 22  |
| Working Pressure : kg/cm <sup>2</sup> | 14  | 14  | 14  | 14  |
| 30m Length Coil dia : cm              | 45  | 45  | 45  | 45  |
| Mass per meter : gm.                  | 275 | 350 | 425 | 480 |
| Abrasion Resistance : Cycles          | 200 | 200 | 200 | 200 |
| Heat Resistance : Seconds             | 8   | 8   | 8   | 8   |

Length : 36 mtr. (Max.)

APPROVED  
BY  
DIRECTORATE  
GENERAL  
OF  
SHIPPING.



## TECHNICAL DATA SHEET HOSEBOX

|   |  |
|---|--|
| <b>TECHNICAL DATA SHEET HOSEBOX</b>     |  |
| <b>A. GENERAL</b>                       |  |
| 1. Manufacturer                         | New Age / Shahbhogilal   |
| 2. Size                                 | 30" X 24" X 10" (750mm x 600mm x 250mm)  |
| 3. Type                                 | Wall Mounted   |
| 4. Front                                | Double Door Front with 3mm Thick Acrylic Sheet   |
| <b>B. MATERIAL OF CONSTRUCTION</b>      | 16 SWG M.S Sheet As Per IS: 513  |
| <b>C. GLASS RECESS</b>                  | Break Glass recess with 1 key provided   |
| <b>D. SUITABLE</b>                      | To accommodate 2 Delivery Hoses Length of 63mm x 15Mtrs. With coupling & 1 No. Branch Pipe & Nozzle Spanner.                                   |
| <b>E. TESTING &amp; QUALITY CONTROL</b> |  |
| 1. Dimension Check                      | As per attached drawing  |
| 2. Documents                            | Internal Inspection Report, Material Test Certificate, Manufacturer's Test certificate   |
| <b>F. PAINTING/ FINISHING</b>           | Outside: Two coats of Fire Red Paint over two coats of Red oxide Primer<br>Inside: Two coats of White Paint over two coats of Red oxide Primer |
| <b>G. MARKING</b>                       | "FIRE"<br>"HOSE"   |

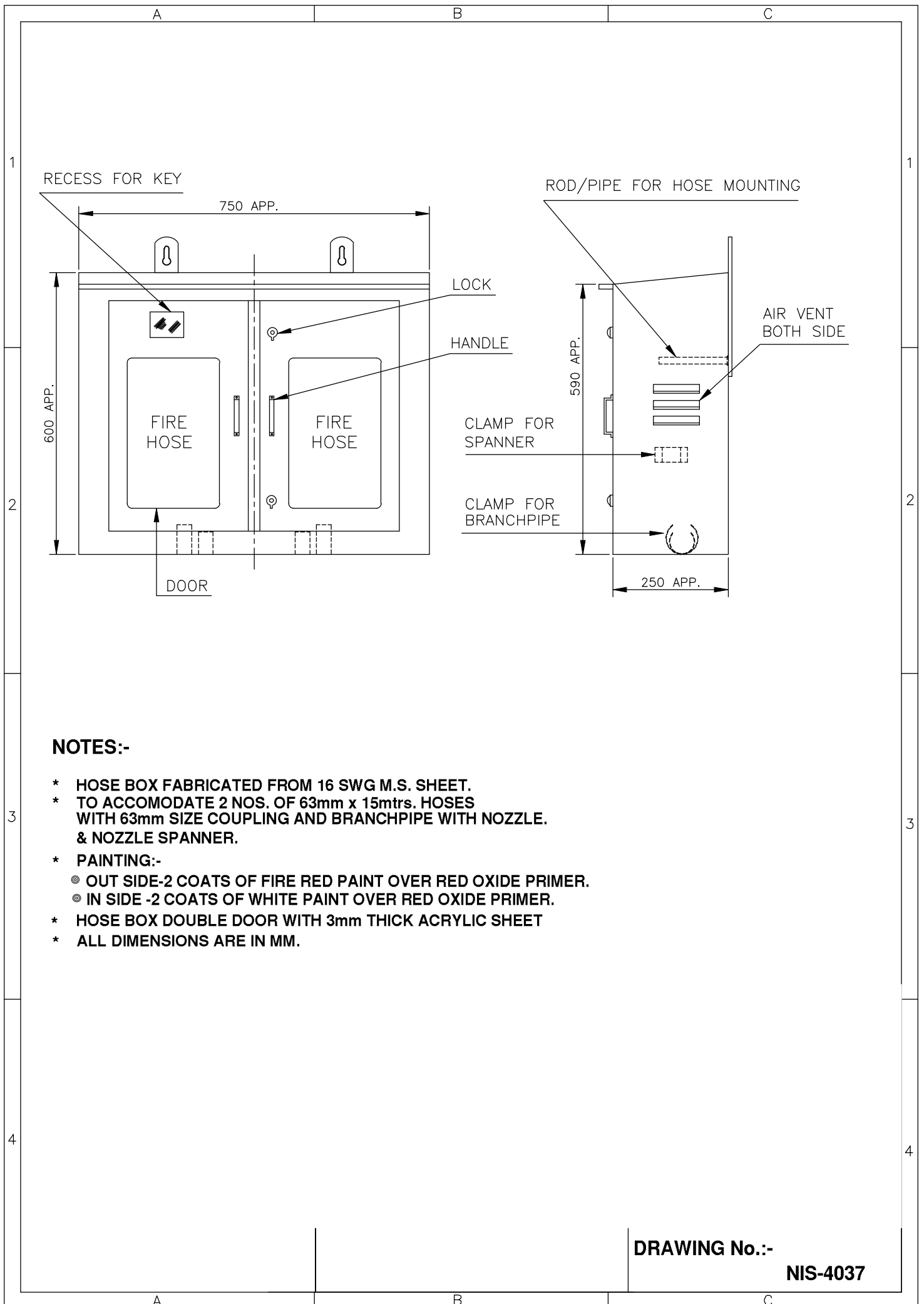

**NOTES:-**

- \* HOSE BOX FABRICATED FROM 16 SWG M.S. SHEET.
- \* TO ACCOMODATE 2 NOS. OF 63mm x 15mtrs. HOSES WITH 63mm SIZE COUPLING AND BRANCHPIPE WITH NOZZLE. & NOZZLE SPANNER.
- \* PAINTING:-
  - ◎ OUT SIDE-2 COATS OF FIRE RED PAINT OVER RED OXIDE PRIMER.
  - ◎ IN SIDE -2 COATS OF WHITE PAINT OVER RED OXIDE PRIMER.
- \* HOSE BOX DOUBLE DOOR WITH 3mm THICK ACRYLIC SHEET
- \* ALL DIMENSIONS ARE IN MM.

**DRAWING No.:-**

**NIS-4037**

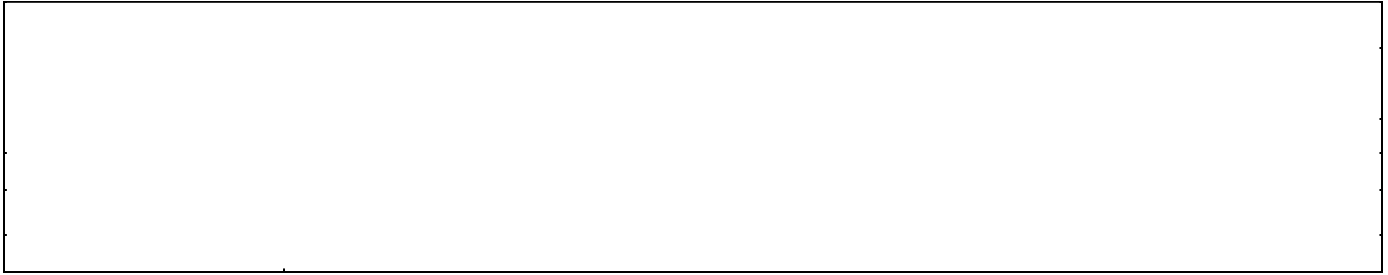

**TECHNICAL DATA SHEET FOR CO2 4.5 KG  
PORTABLE TYPE FIRE EXTINGUISHER**

| <b>DESCRIPTION</b>            | <b>SPECIFICATION</b>   |
|-------------------------------|--|
| <b>MAKE</b>                   | SAFEX FIRE / KANEX   |
| <b>NUMBER OFFERED</b>         | AS PER APPROVED DRAWING / LOA  |
| <b>OPERATING TEMPERATURE</b>  | -20°C- +55°C   |
| <b>MARKING</b>                | AS PER IS:15683  |
| <b>MATERIAL</b>               |  |
| BODY                          | SEAMLESS PIPE CONFORMING TO IS:7285 ISI MARKED                             |
| DISCHARGE VALVE               | WHEEL TYPE (CONFORMING TO IS:3234) ISI MARKED                              |
| SYPHON TUBE                   | ALUMINIUM CONFORMING TO IS:738   |
| TEST PRESSURE OF BODY         | 250 KG/CM2   |
| DISCHARGE HORN                | NON CONDUCTOR OF ELECTRICITY LIKE<br>POLYTHENE FIBRE GLASS                 |
| <b>CO2 GAS</b>                | IS:15222   |
| <b>PAINTING</b>               | P.O RED CONFORMING TO SHADE NO. 538 OF IS: 5                               |
| <b>DISCHARGE</b>              | NOT LESS THAN 95% WITHIN 25 SEC.   |
| <b>MINIMUM DISCHARGE TIME</b> | 8 SEC.   |
| <b>FIRE RATING</b>            | 21B  |
| <b>HEIGHT &amp; DIA</b>       | 710 +/-10, 140 MM.   |
| <b>EMPTY WEIGHT</b>           | 12.5 KGS APPROX  |
| <b>FULL WEIGHT</b>            | 17 KGS APPROX  |
| <b>HOSE</b>                   | BRAIDED RUBBER HOSE HAVING 200 KGF/CM2<br>BURSTING PRESSURE 1 METER LENGTH |



Powering your way to safety  
Since 1972



## Wheel / Squeeze Grip Type Co2 Fire Extinguisher

| FIRE EXTINGUISHER CAPACITY                          | 2kg.Wheel              | 3kg.Wheel              | 4.5kg.Wheel            | 2kg.Squeeze            | 3kg.Squeeze            | 4.5kg.Squeeze          |
|---|------------------------|------------------------|------------------------|------------------------|------------------------|------------------------|
| MINIMUM PERIOD FOR WHICH THROW OF JET MAINTAINED    | 8 sec                  | 8 sec                  | 8 sec                  | 8 sec                  | 8 sec                  | 8 sec                  |
| MINIMUM PERIOD TO DISCHARGE ATLEAST 90% OF CONTESTS | 10 sec                 | 16 sec                 | 20 sec                 | 10 sec                 | 16 sec                 | 25 sec                 |
| RANGE OF JET  | 1 mtr.                 | 1 mtr.                 | 2 mtr.                 | 1 mtr.                 | 1 mtr.                 | 2 mtr.                 |
| EMPTY. WT. (APPROX)                                 | 6.2kg.                 | 9.5kg.                 | 12.5kg.                | 6.2kg.                 | 9.5kg.                 | 12.5kg.                |
| FULL WT. (APPROX)                                   | 8.2kg.                 | 12.5kg.                | 17kg.                  | 8.2kg.                 | 12.5kg.                | 17kg.                  |
| FIRE RATING   | 8B                     | 13B                    | 21B                    | 13B                    | 21B                    | 21B                    |
| WORKING PRESSURE                                    | 60KGF/CM <sup>2</sup>  | 60KGF/CM <sup>2</sup>  | 60KGF/CM <sup>2</sup>  | 60KGF/CM <sup>2</sup>  | 60KGF/CM <sup>2</sup>  | 60KGF/CM <sup>2</sup>  |
| HYDRO PRESSURE                                      | 250KGF/CM <sup>2</sup> | 250KGF/CM <sup>2</sup> | 250KGF/CM <sup>2</sup> | 250KGF/CM <sup>2</sup> | 250KGF/CM <sup>2</sup> | 250KGF/CM <sup>2</sup> |
| BRUSTING PRESSURE                                   | 600KGF/CM <sup>2</sup> | 600KGF/CM <sup>2</sup> | 600KGF/CM <sup>2</sup> | 600KGF/CM <sup>2</sup> | 600KGF/CM <sup>2</sup> | 600KGF/CM <sup>2</sup> |

IS:15683

## Trolley Mounted Type Co2 Fire Extinguisher

| FIRE EXTINGUISHER CAPACITY                          | 6.5kg.                 | 9kg.                   | 22.5kg.                |
|---|------------------------|------------------------|------------------------|
| MINIMUM PERIOD FOR WHICH THROW OF JET MAINTAINED    | 10 sec                 | 15 sec                 | 20 sec                 |
| MINIMUM PERIOD TO DISCHARGE ATLEAST 90% OF CONTESTS | 20 sec                 | 36 sec                 | 60 sec                 |
| RANGE OF JET  | 2 mtr.                 | 2 mtr.                 | 2 mtr.                 |
| EMPTY. WT. (APPROX)                                 | 20kg.                  | 26kg.                  | 43.5kg.                |
| FULL WT. (APPROX)                                   | 26.5kg.                | 35kg.                  | 66kg.                  |
| FIRE RATING   | N/A                    | N/A                    | N/A                    |
| WORKING PRESSURE                                    | 60KGF/CM <sup>2</sup>  | 60KGF/CM <sup>2</sup>  | 60KGF/CM <sup>2</sup>  |
| HYDRO PRESSURE                                      | 250KGF/CM <sup>2</sup> | 250KGF/CM <sup>2</sup> | 250KGF/CM <sup>2</sup> |
| BRUSTING PRESSURE                                   | 600KGF/CM <sup>2</sup> | 600KGF/CM <sup>2</sup> | 600KGF/CM <sup>2</sup> |

IS:2878



Approvals and Accreditation:



## TECHNICAL DATA SHEET FOR GATE VALVES

|  |                                |
|--|--------------------------------|
| MAKE   | KALPANA/ LEADER VALVE          |
| SIZE (NB)                                    | 50mm TO 300mm                  |
| SPECIFICATION                                | IS:14846 PN-1.0 & PN-1.6       |
| END CONNECTION                               | FLANGED                        |
| MATERIAL OF CONSTRUCTION                     | IS:780                         |
| BODY   | CAST IRON IS 210 FG220         |
| BODY SEAT RING                               | Bronze IS: 318 Gr. LTB 2       |
| STEM   | S.S AISI-410                   |
| END CONNECTION                               | Flanged to ANSI B 16.5 #150 FF |
| WHETHER RISING SPINDLE OR NON RISING SPINDLE | RISING SPINDLE                 |
| CERTIFICATION                                | BS MARKED                      |
| GATE VALVE PROVIDED WITH:                    |                                |
| A) HAND WHEEL                                | YES                            |
| B) DRAINING ARRANGEMENT                      | YES                            |
| C) LOCKING FACILITY(Where necessary)         | YES                            |
| HAND WHEEL                                   | GREY CAST IRON IS 210 FG220    |
| OPEN & CLOSE INDICATION                      | PROVIDED                       |
| HYDRAULIC TEST PRESSURE                      |                                |
| FOR BODY                                     | 24 kg/cm <sup>2</sup>          |
| FOR SEAT                                     | 16 kg/cm <sup>2</sup>          |
| GATE/GLOBE VALVE                             |                                |
| SIZE (NB)                                    | 25mm TO 40mm                   |
| SPECIFICATION                                | IS: 778/BS-5150                |
| END CONNECTION                               | SCREWED                        |
| MATERIAL OF CONSTRUCTION                     | FOR SIZE BELOW 50mm Dia.       |
| BODY   | LTB-II                         |
| VALVE TRIMS                                  | IS:318                         |

# SLUICE VALVE II

## RISING STEM, OUTSIDE SCREW

### CAST IRON

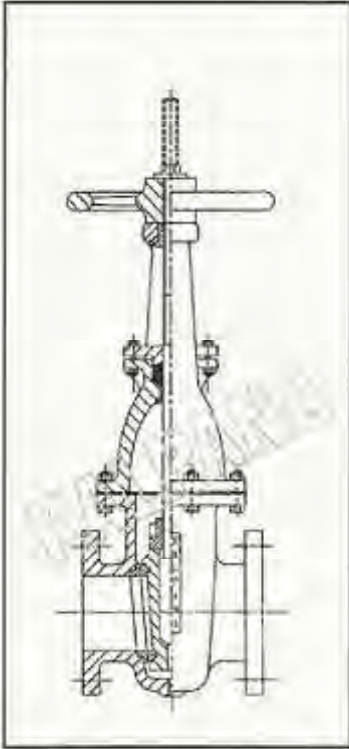

Size up to 150 mm.

**Normal Standard :** BS : 5150, ASA class 125 Lb or outside screw rising type with Valve face to face dimension similar to IS :14846, DIN or as per Customer's requirement.

**Pressure Rating :** PN-1.0 & PN-1.6.

**Operation Arrangement :** Hand wheel, Electrical/ Pneumatic Actuator or Servocontrol and Gear Box for manual operation.

**Special Arrangement :** Drain Plug, Indicator, Chain Wheel and Locking Arrangement,

**End Connection :** Flanges may be as per customer's requirement.

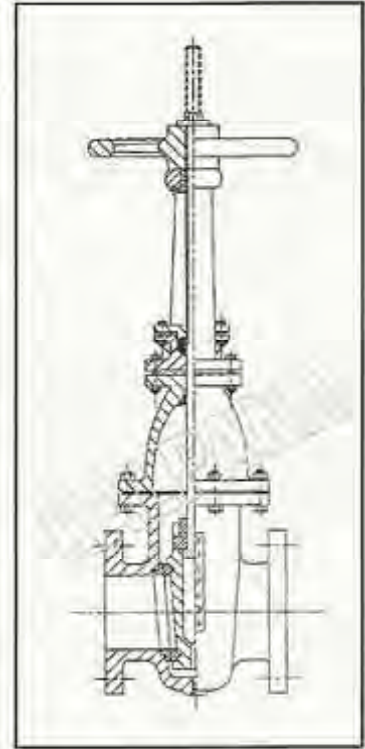

Size above 150 mm.

#### TEST PRESSURE

|      | P.N.-1.0             | P.N.-1.6             |
|------|----------------------|----------------------|
| Body | 15kg/cm <sup>2</sup> | 24kg/cm <sup>2</sup> |
| Seat | 10kg/cm <sup>2</sup> | 16kg/cm <sup>2</sup> |

#### Dimensions in mm.

| Size                             | 50  | 65  | 80  | 100 | 125 | 150 | 200  | 250  | 300  |
|----------------------------------|-----|-----|-----|-----|-----|-----|------|------|------|
| Face to Face                     | 178 | 190 | 203 | 229 | 254 | 267 | 292  | 330  | 356  |
| Centre of water way to Top (Max) | 510 | 560 | 610 | 720 | 875 | 950 | 1200 | 1440 | 1675 |

#### Dimensions in mm.

| Size                             | 350  | 400  | 450  | 500  | 600  | 700  | 750  | 800  | 900  | 1000 | 1100 | 1200 |
|----------------------------------|------|------|------|------|------|------|------|------|------|------|------|------|
| Face to Face                     | 381  | 406  | 432  | 457  | 508  | 610  | 610  | 660  | 711  | 811  | 1650 | 1800 |
| Centre of water way to Top (Max) | 1900 | 2070 | 2250 | 2430 | 2850 | 3250 | 3500 | 3750 | 4150 | 4450 | 4750 | 5100 |

## TECHNICAL DATA SHEET FOR ADDRESSABLE MANUAL CALL POINT

| DESCRIPTION          | SPECIFICATION              |
|----------------------|----------------------------|
| Manufacturer         | SHRACK /APPOLO/NOTIFIER    |
| Operating voltage:   | 7 to 31 VDC                |
| Quiescent current:   | Max. 120 $\mu$ A at 30 VDC |
| Alarm Current :      | 2.5 mA                     |
| Connection :         | Integral X-LINE            |
| Screw terminal:      | Max. 2.5 mm <sup>2</sup>   |
| Signal transmission: | Serial , 2- wire           |
| Ambient temperature: | -20°C to +50°C             |

# Handfeuermelder MCP 545X. Manual callpoint MCP 545X.



## Beschreibung

Die Handfeuermelder MCP 545X sind geeignet zum Anschluss an die Integral X-LINE.

Die drei verschiedenen Ausführungen unterscheiden sich lediglich durch ihre Gehäuseform (IP-Schutzart), Elektronik, Anschaltung und Funktion ist bei allen Typen ident.

Die Melder enthalten einen Kurzschlussisolator und eine rote Alarm-LED. Die Alarmauslösung erfolgt durch Eindrücken der Glasscheibe bzw. Drücken des Kunststoff-Plättchens. Der Alarm bleibt bis zum Wiedereinsetzen einer neuen Glasscheibe bestehen bzw. resetieren des Kunststoff Plättchen bestehen. Ein Prüf-schlüssel dient zur Funktionsprüfung.

Der MCP 545X-1 ist geeignet für Innenanwendungen und wird Aufputz montiert. Die Dose wird mit zwei Schrauben an der Wand befestigt, dabei müssen die Befestigungspunkte für den Tasterteil waagrecht sein. Eventuell nötige Kabeleinführungen für AP-Installationen müssen aufgebohrt werden.

Der MCP 545X-2 ist geeignet für Innenanwendungen und wird direkt in eine handelsübliche Unterputzdose Größe 1 (rund od. viereckig) eingebaut. Der Befestigungsloch-Abstand beträgt 60 mm waagrecht.

Der MCP 545X-3 ist auch für Außenanwendungen geeignet und wird Aufputz montiert. Der Melder verfügt über Schutzart IP 67 (wasserfest); die Kabeleinführung erfolgt mittels Kabelverschraubung M 20 von unten oder oben. Die Dose des Melders wird mit drei Schrauben an der Wand befestigt.

- einfache Installation • Gehäuse in rot, blau oder gelb • Schutzart IP 24 bis IP 67 • Alarmanzeige mittels LED • Störungsmeldung bei Bauteilausfall • Melder einzeln abschaltbar • integrierter Kurzschlussisolator • geprüft nach EN 54-11 & EN 54-17.

- easy installation • case available in red, blue or yellow • IP protection class from IP 24 up to IP 67 • alarm indication by LED • fault message in the event of a component failure • detectors can be individually disabled • integrated short circuit isolator • approved according to EN 54-11 & EN 54-17.

## Description

The manual call points MCP 545X are suitable for the connection to the Integral X-LINE.

The three different versions differ only from the shape of the housing (IP protection category). Electronics, connection and function are the same for all types.

The detectors contain a short circuit isolator and a red alarm LED. An alarm is released directly when the glass pane is broken or the plastic pane is pressed. The alarm condition remains active, until the glass pane is replaced by a new one or the plastic pane is reset. A test key is available for function test.

The MCP 545X-1 is suitable for indoor applications and surface-mounting. The surface-mounted box is fastened to the wall with two screws. The fastening points for the switch part must be horizontal. Any necessary cable entries for surface-mounted installations must be drilled.

The MCP 545X-2 is suitable for indoor applications and is mounted in a commercial flush-mounted box (size 1; round or square). The horizontal distance between the mounting holes is 60 mm.

The MCP 545X-3 is also suitable for outdoor applications and surface-mounting. The detector has protection category IP 67 (waterproof); the cable entry is carried out by means of cable gland M20 from the bottom. The mounting box is attached to the wall with three screws.



# Handfeuermelder MCP 545X. Manual callpoint MCP 545X.

## Abmessungen Dimensions

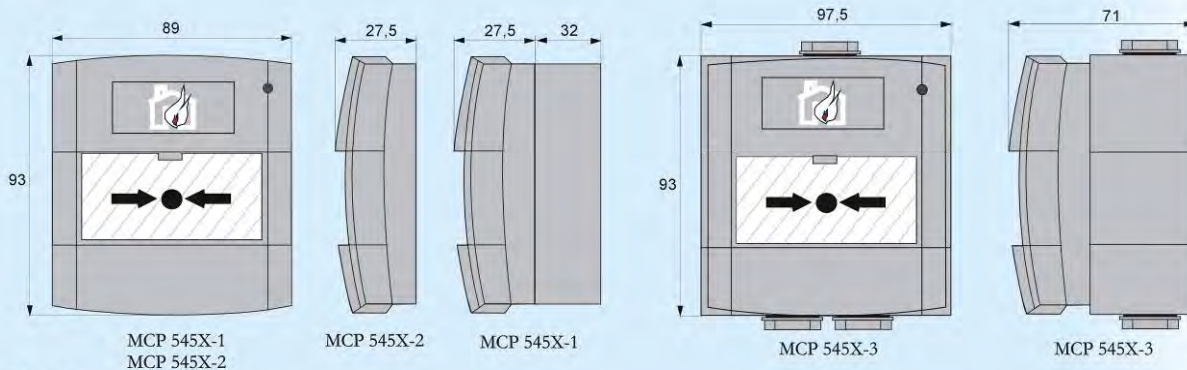

Alle Maße in mm  
All dimensions in mm

## Technische Daten

|                      |  |
|----------------------|--|
| Betriebsspannung:    | 7 bis 31 VDC   |
| Ruhestrom:           | max. 120 µA bei 30 VDC   |
| Alarmstrom:          | 2,5 mA   |
| Anschaltung:         | Integral X-LINE  |
| Schraubanschlüsse:   | max. 2,5 mm <sup>2</sup>   |
| Signalübertragung:   | seriell, 2-Leiter-Technik  |
| Schutzart            |  |
| MCP 545X-1/2:        | IP 24  |
| MCP 545X-3:          | IP 67  |
| Umgebungstemperatur: | -20° bis +50°C   |
| Gehäuse Farbe:       | rot, RAL 3001<br>gelb, RAL 1006<br>blau, RAL 5002  |
| Gehäuse Material:    | Kunststoff, glasfaserverstärkt   |
| Gewicht              |  |
| MCP 545X-1/2:        | 160 g/110 g  |
| MCP 545X-3:          | 240 g  |
| Zulassung:           | rot, G210092<br>(EN 54-11: 2001, EN 54-17: 2005)<br>gelb, entsprechend (EN 54-11: 2001,<br>EN 54-17: 2005)<br>blau, entsprechend (EN 54-11: 2001,<br>EN 54-17: 2005) |
| CPD-Zertifikat:      | rot, 0786-CPD-20998  |

## Technical data

|                      |  |
|----------------------|--|
| Operating voltage:   | 7 to 31 VDC  |
| Quiescent current:   | max. 120 µA at 30 VDC  |
| Alarm current:       | 2,5 mA   |
| Connection:          | Integral X-LINE  |
| Screw terminals:     | max. 2,5 mm <sup>2</sup>   |
| Signal transmission: | serial, 2-wire   |
| Protection class     |  |
| MCP 545X-1/2:        | IP 24  |
| MCP 545X-3:          | IP 67  |
| Ambient temperature: | -20° to +50°C  |
| Housing colour:      | red, RAL 3001<br>yellow, RAL 1006<br>blue, RAL 5002  |
| Housing material:    | plastic, glass fibre-reinforced  |
| Weight               |  |
| MCP 545X-1/2:        | 160 g/110 g  |
| MCP 545X-3:          | 240 g  |
| Approval:            | red, G210092<br>(EN 54-11: 2001, EN 54-17: 2005)<br>yellow, according (EN 54-11: 2001,<br>EN 54-17: 2005)<br>blue, according (EN 54-11: 2001,<br>EN 54-17: 2005) |
| CPD-Certificate:     | red, 0786-CPD-20998  |

Weitere Informationen sind der Technischen Dokumentation zu entnehmen.  
Further informations can be obtained from the technical documentation.

Schrack Seconet AG

A-1122 Wien/Vienna, Eibesbrunnnergasse 18, T.EL.: +43-1-81157-0, office@schrack-seconet.com

**FIRE ALARM**

**SCHRACK**  
S E C O N E T

www.schrack-seconet.com

© Schrack Productions - B-DB-0088DE-EN-MCP 545X - V1.0  
Technische Änderungen vorbehalten - subject to technical modifications

## TECHNICAL DATA SHEET FOR MULTI-SENSOR DETECTOR

| DESCRIPTION           | SPECIFICATION                               |
|-----------------------|---|
| Manufacturer          | SHRACK /APPOLO/NOTIFIER                     |
| Operating voltage     | 12 to 30 VDC (without modulation amplitude) |
| Quiescent Current     | 120 $\mu$ A typ                             |
| Alarm output          | 3 level programmable 0.1 mA/1mA/5mA         |
| Alarm Led active      | 1.6 mA                                      |
| Alarm current         | min. 0.5mA max. 10 mA                       |
| Output current        | programmable                                |
| X-Line                | 5V  |
| Loop technology       | 6.3 V                                       |
| Detector base:        | USB 501-x                                   |
| Principle of function | Combined smoke/heat detector(NTC sensor)    |
| Weight                | About 125 g                                 |
| Ambient temperature   | -25° to +60°C                               |
| Air velocity          | Max. 20 m/s                                 |
| Case material         | ABS/PC                                      |
| Protection class      | IP 44 (with base USB 501-1)                 |

# Mehrfachsensormelder MTD 533X.

## Multiple Sensor Detector MTD 533X.



### Beschreibung

Der Mehrfachsensormelder MTD 533X kann je nach Bedarf und Anwendung als Rauch-, als Temperatur-, oder als kombinierter Melder eingesetzt werden und wird jeweils entsprechend seinem Einsatzgebiet anlagen-spezifisch programmiert und eingestellt. Er erkennt frühzeitig Schwelbrände und offene Brände, indem er sowohl die Brandkenngroße Rauch (mittels Tyndall-Prinzip) als auch Wärme (NTC-Sensor-Prinzip) detektieren und auswerten kann. Die Empfindlichkeit kann über Software im Rahmen der EN 54 angepasst werden.

Der Melder verfügt über einen integrierten Kurzschlussisolator, der es im Kurzschlussfall auf einer Ringleitung ermöglicht, das schadhafte Leitungselement zu isolieren und den Betrieb aller Melder aufrecht zu erhalten.

Ein dynamischer Alarmfilter dient zum Erkennen und Ausfiltern von Täuschungsgrößen, darüber hinaus kann bei Bedarf ein Voralarm ausgewertet und an die Zentrale weitergeleitet werden. Wechselnde Umwelteinflüsse werden kompensiert, indem sich der Melder in regelmäßigen Abständen automatisch an seine Umgebung anpasst.

Die Montage und Installation des MTD 533X erfolgt mittels der Montagesockel-Serie USB 501.

Für die Projektierung gelten die länderspezifischen Richtlinien für Planung und Einbau von automatischen Brandmeldeanlagen. Für kombinierte Brandmelder können zusätzliche Richtlinien gelten, sofern dauernd oder zeitweise eine der Detektionseigenschaften abgeschaltet wird.

- ein Melder für alle Anwendungen • Branderkennung immer mittels Rauch- und Temperatureauswertung • optimierte Rauchkammer • Rauchvoralarm bei 30 % und bei 75 % der Alarmschwelle • Speicherung aller Melderdaten und Ereignisse • dynamische Anpassung an Umgebungsbedingungen • 2-stufige Verschmutzungserkennung • parametrierbare Wärmeklassen gemäß EN 54 • LED Alarmanzeige 360° sichtbar • integrierter Kurzschlussisolator • VdS-Zulassung

- one detector for all applications • fire detection always carried out by means of smoke and temperature evaluation • optimized smoke chamber • Smoke pre-alarm at 30 % and at 75 % of the alarm threshold • all detector data and events are stored • adapts dynamically to surrounding conditions • 2 stage pollution detection • adjustable temperature classes acc. to EN 54 • LED alarm indicator 360° visible • integrated short circuit isolator • VdS-approval

### Description

The MTD 533 multiple sensor detector can be used as a smoke detector, as a heat detector or as a combined smoke/heat detector upon demand and is programmed and set-up specifically for the environmental conditions that it is part of. It detects smouldering and open fires at an early stage by being able to detect and evaluate the characteristics of fire and smoke (Tyndall principle) as well as heat (NTC sensor principle). The sensitivity of the detector can be adjusted using software within the scope of EN 54.

The detector provides an integrated short circuit isolator that, in case of a short circuit on the loop, enables the isolation of the faulty element while maintaining the operation of all other detectors.

A dynamic alarm filter is used to detect and filter out deceptive alarms, furthermore a pre-alarm can be evaluated and forwarded to the control panel, if required. To compensate changing environmental influences, the detector adjusts itself at periodic intervals to its surroundings.

The assembly and installation is done by means of the mounting base series USB 501.

For planning and installation, the country-specific guidelines for planning and installation of automatic fire alarm systems apply. It could be possible, that additional guidelines and regulations for combined fire detectors must be taken into account, if continuously or temporarily one of the detection principles is switched off.

# Mehrfachsensormelder MTD 533X.

## Multiple Sensor Detector MTD 533X.

### Abmessungen Dimensions

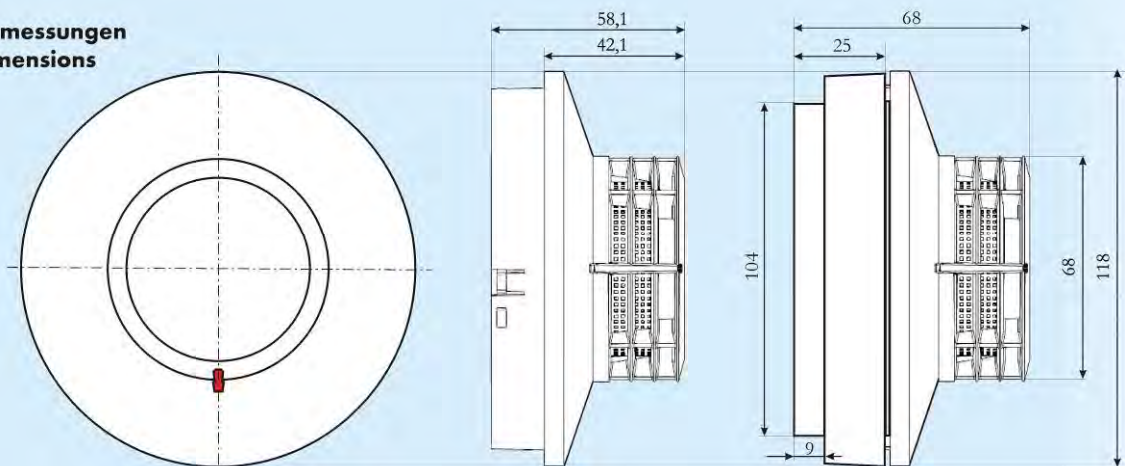

Alle Maße in mm  
All dimensions in mm

mit Meldersockel/with detector base  
USB 501-1 oder/ot USB 501-6

### Technische Daten

|                        |  |
|------------------------|--|
| Betriebsspannung:      | 12 bis 30 VDC (ohne Modulationshub)                        |
| Ruhestrom:             | 120 µA typ.  |
| Alarmausgang:          | 3 Stufen programmierbar<br>0,1 mA/1 mA/5 mA                |
| Alarm-LED aktiv:       | 1,6 mA   |
| Alarmstrom:            | min. 0,5 mA, max. 10 mA                                    |
| Ausgangsspannung:      | programmierbar   |
| X-LINE:                | 5 V  |
| Ringleitung:           | 6,3 V  |
| Meldersockel:          | USB 501-x  |
| Funktionsprinzip:      | Kombinierter Rauch/Wärmemelder (Tyndall-Effekt/NTC Sensor) |
| Signalübertragung:     | serielle Biphase Datenübertragung, 2-Leiter-Technik        |
| Empfindlichkeit:       | Rauch nach EN 54-7   |
| Empfindlichkeit:       | Wärme nach EN 54-5; Klassen A1, A2, B (Index S und R)      |
| Schutzart:             | IP 44 (mit Sockel USB 501-1)                               |
| Umgebungstemperatur:   | -25° bis +60°C   |
| Rel. Luftfeuchtigkeit: | dauernd, ohne Betauung:                                    |
| bei ≤ 34 °C:           | 10 ... 95 % rel/F  |
| bei > 34 °C:           | max. 35 g/m <sup>3</sup> min. 10 % rel/F                   |
| Luftgeschwindigkeit:   | max. 20 m/s  |
| Abmessungen:           | siehe Maßzeichnung oben                                    |
| Gehäuse Farbe:         | weiß ähnlich RAL 9003<br>alle RAL Farben auf Anfrage       |
| Gehäuse Material:      | ABS/PC   |
| Gewicht:               | 125 g  |
| CE-Zertifikat:         | 0786-CPD-20993   |
| VdS-Zulassung:         | G210115  |

### Technical data

|                        |   |
|------------------------|---|
| Operating voltage:     | 12 to 30 VDC (without modulation amplitude)   |
| Quiescent current:     | 120 µA typ.   |
| Alarm output:          | 3 levels programmable<br>0,1 mA/1 mA/5 mA   |
| Alarm-LED active:      | 1,6 mA  |
| Alarm current:         | min. 0,5 mA, max. 10 mA   |
| Output current:        | programmable  |
| X-LINE:                | 5 V   |
| Loop technology:       | 6,3 V   |
| Detector base:         | USB 501-x   |
| Principle of function: | Combined smoke/heat detector (Tyndall effect and/or NTC sensor)                       |
| Signal transmission:   | serial biphase data transmission, 2-wire -technology                                  |
| Sensitivity:           | smoke acc. to EN 54-7<br>heat acc. to EN 54-5; (classes A1, A2 and B (Index S and R)) |
| Protection class:      | IP 44 (with base USB 501-1)   |
| Ambient temperature:   | -25° to +60°C   |
| Rel. humidity:         | permanent, without condensation:  |
| at ≤ 34 °C:            | 10 ... 95 % rel/F   |
| at > 34 °C:            | max. 35 g/m <sup>3</sup> min. 10 % rel/F  |
| Air velocity:          | max. 20 m/s   |
| Dimensions:            | see drawing above   |
| Case colour:           | white similar to RAL 9003<br>all RAL colours upon request                             |
| Case material:         | ABS/PC  |
| Weight:                | 125 g   |
| CE-Certificate:        | 0786-CPD-20993  |
| VdS-Approval:          | G210115   |

Weitere Informationen sind der Technischen Dokumentation zu entnehmen.  
Further informations can be obtained from the technical documentation.

© Schrack-Productions - B-DB-0094DE-EN - V1.0  
Technische Änderungen vorbehalten - subject to technical modifications

SCHRACK SECONET AG

A-1122 Wien, Eibesbrunnnergasse 18 • Tel.: +43-1-81157-0 • office@schrack-seconet.com

**FIRE ALARM**

www.schrack-seconet.com

**SCHRACK**  
S E C O N E T

## TECHNICAL DATA SHEET FOR CONTROL MODULE

|                         |   |
|-------------------------|---|
| <b>MANUFACTURER</b>     | SHRACK /APPOLO/NOTIFIER                               |
| Operating voltage       | 12 to 30 VDC.   |
| Current consumption     | Typ. 550 $\mu$ A                                      |
| Signal transmission     | Serial, 2 wire technology                             |
| Relay output            | Bistable change-over contracts 230V /2A, (max. 60 W ) |
| Optocoupler input       | 0-30 VDC  |
| Connection:             | Screw clips, max. 1.5 mm <sup>2</sup>                 |
| Short circular isolator | Integrated  |
| Protection class        | IP 66 with case                                       |
| Ambient temperature     | -20° to +60°C   |
| Relative air humidity   | 5 to 95% without condensation                         |
| Dimensions              | 67x67x20 mm (with case 94x94x20 mm)                   |
| Case:                   | Polystyrol, halogen-free                              |
| Colour:                 | Grey (RAL 7035)                                       |

# Ein-/Ausgangsmodul BX-O13. Input/Output Module BX-O13.



## Beschreibung

Das Ein-/Ausgangsmodul BX-O13 ist geeignet zum Anschluss an die Integral X-LINE.

Es enthält einen Relaisausgang mit programmierbarer Fail-Safe-Lage, zwei Eingänge für die überwachte Abfrage von potentialfreien Kontakten und einen Optokopplereingang, welcher bei Bedarf zur Überwachung einer externen Spannung verwendet werden kann.

Das BX-O13 ist besonders geeignet zur Einbindung von Sondermeldern (Flammen- und Linearmelder, Rauchansaugsysteme, etc.) in die Integral X-LINE. Sowohl die Adressierung des Moduls, als auch die Einstellung der Parameter für die angeschalteten Sondermelder (z.B. deren Verhalten bei Alarm und Störung) erfolgt mittels PC-Software über die Brandmelderzentrale.

Das BX-O13 enthält einen Kurzschlussisolator, welcher im Fall von Drahtbruch oder Kurzschluss dafür sorgt, dass der Fehler lokalisiert wird und gleichzeitig der Betrieb der Ringleitung in vollem Funktionsumfang erhalten bleibt, zusätzlich wird die Spannung auf der Ringleitung intern auf Unterspannung überwacht.

Das BX-O13 ist in ein Kunststoffgehäuse mit Schutzart IP 66 eingebaut, welches je nach Bedarf mit verschiedenen Kabeleinführungen ausgestattet werden kann.

Die Verwendung eines geschirmten Brandmeldekabels wird empfohlen, besonders in Bereichen, wo EMV-Störgrößen vorhanden sind, oder solche bedingt durch Arbeitsprozesse periodisch auftreten können.

Für die Projektierung gelten die landesspezifischen Richtlinien für Planung und Einbau von automatischen Brandmeldeanlagen.

- Relaisausgang mit programmierbarer Fail-Safe-Lage
- 2 überwachte Eingänge
- 1 Optokopplereingang
- Einfache Einbindung von Sondermeldern
- Geringer Stromverbrauch
- Hohe Störfestigkeit durch spezielles Energiemanagement
- Integrierter Kurzschlussisolator
- Gehäuse erfüllt Schutzklasse IP 66.

- relay output with programmed fail-safe position
- 2 monitored inputs
- 1 optocoupler input
- simple implementation of special detectors
- low power consumption
- high resistance against faults thanks to special energy management
- integrated short circuit isolator
- case satisfies IP 66 protection class.

## Description

The input/output module BX-O13 is suitable for the connection to Integral X-LINE.

It contains a relay output with a programmable fail-safe position, two inputs for monitored querying of potential-free contacts and an optocoupler input which can be used, if required, for monitoring external voltages.

The BX-O13 is particularly well-suited for connecting special detectors (flame and line detectors, smoke aspirating systems etc.) using Integral X-LINE. Addressing of the module as well as setting the parameters for connected special detectors (e.g. how they behave when there is an alarm or a fault) is carried out via the fire alarm control panel using PC software.

The BX-O13 contains a short circuit isolator which guarantees, that a possible failure is located and that the loop stays in unrestricted function even in case of a wire break or a short circuit, in addition the voltage on the loop line is internally monitored on under voltage.

The BX-O13 is installed in a IP 66 protection class plastic case, which can be fitted with different cable inlets depending on requirements.

A shielded cable installation is recommended, particularly in cases, where electromagnetic disturbances occur, or such could be caused periodically during working processes.

The country-specific guidelines for planning and installation of automatic fire alarm systems are applicable.

# Ein-/Ausgangsmodul BX-OI3. Input/Output Module BX-OI3.

## Abmessungen Dimensions

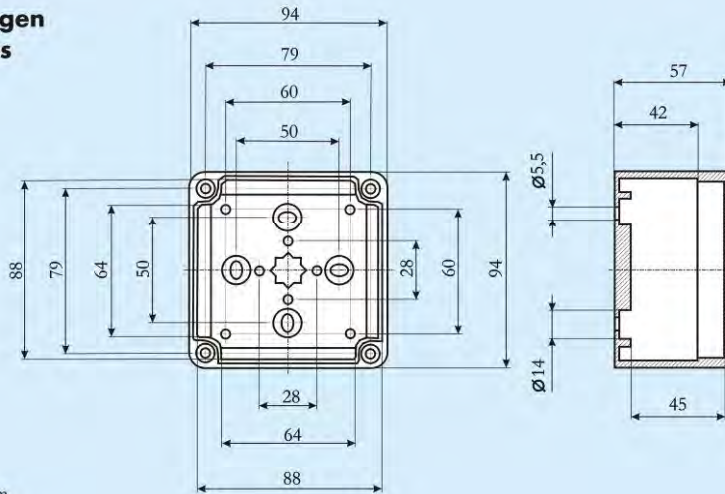

Alle Maße in mm  
All dimensions in mm

## Technische Daten

**Betriebsspannung:** 12 bis 30 VDC  
**Stromverbrauch:** typ. 550  $\mu$ A  
**Signalübertragung:** seriell, 2-Leiter-Technik  
**Relaisausgang:** bistabiler Umschaltekontakt  
 230 V/2 A, (max. 60 W)  
**Überwachte Eingänge:** für potentialfreie Kontakte  
**Optokopplereingang:** Abfrage von potentialgebundenen  
 Signalen, bzw. externen  
 Spannungen von 0 bis 30 VDC  
**Anschluss:** Schraubklemmen, max. 1,5 mm<sup>2</sup>  
**Kurzschlussisolator:** integriert  
**Schutzart:** IP 66 mit Gehäuse  
**Umgebungstemperatur:** -20° bis +60°C  
**Rel. Luftfeuchtigkeit:** 5 bis 95% ohne Kondensation  
**Abmessungen:** 67 x 67 x 20 mm  
 (mit Gehäuse 94 x 94 x 57 mm)  
**Gehäuse:** Polystyrol, halogenfrei  
**Farbe:** grau (RAL 7035)  
**VdS-Zulassung:** G210133  
**CE-Zertifikat:** 0786-CPD-21011

## Technical data

**Operating voltage:** 12 to 30 VDC  
**Current consumption:** typ. 550  $\mu$ A  
**Signal transmission:** serial, 2 wire technology  
**Relay output:** bistable change-over contact  
 230 V/2 A, (max. 60 W)  
**Monitored inputs:** for potential-free contacts  
**Optocoupler input:** Querying potentially-charged  
 signals, or external voltages of  
 0-30 VDC  
**Connection:** Screw clips, max. 1.5 mm<sup>2</sup>  
**Short circuit isolator:** integrated  
**Protection class:** IP 66 with case  
**Ambient temperature:** -20° to +60°C  
**Relative air humidity:** 5 to 95% without condensation  
**Dimensions:** 67 x 67 x 20 mm  
 (with case 94 x 94 x 57 mm)  
**Case:** Polystyrol, halogen-free  
**Colour:** grey (RAL 7035)  
**VdS-Approval:** G210133  
**CE-Certificate:** 0786-CPD-21011

Weitere Informationen sind der Technischen Dokumentation zu entnehmen.  
 Further informations can be obtained from the technical documentation.

© Schrack Productions – B-DB0068DE – EN – BX-OI3 – V1.1 – 11.2010  
 Technische Änderungen vorbehalten – subject to technical modifications

SCHRACK SECONET AG

A-1122 Wien, Eibesbrunnengasse 18 • Tel.: +43-1-81157-0 • office@schrack-seconet.com

**FIRE ALARM**

www.schrack-seconet.com

**SCHRACK**  
S E C O N E T