



cool with

HITEMA[®]



hitema.com

international



PROCESS COOLING APPLICATION SERIES - TECHNICAL SPECIFICATIONS
ENR - ENRF - CSE

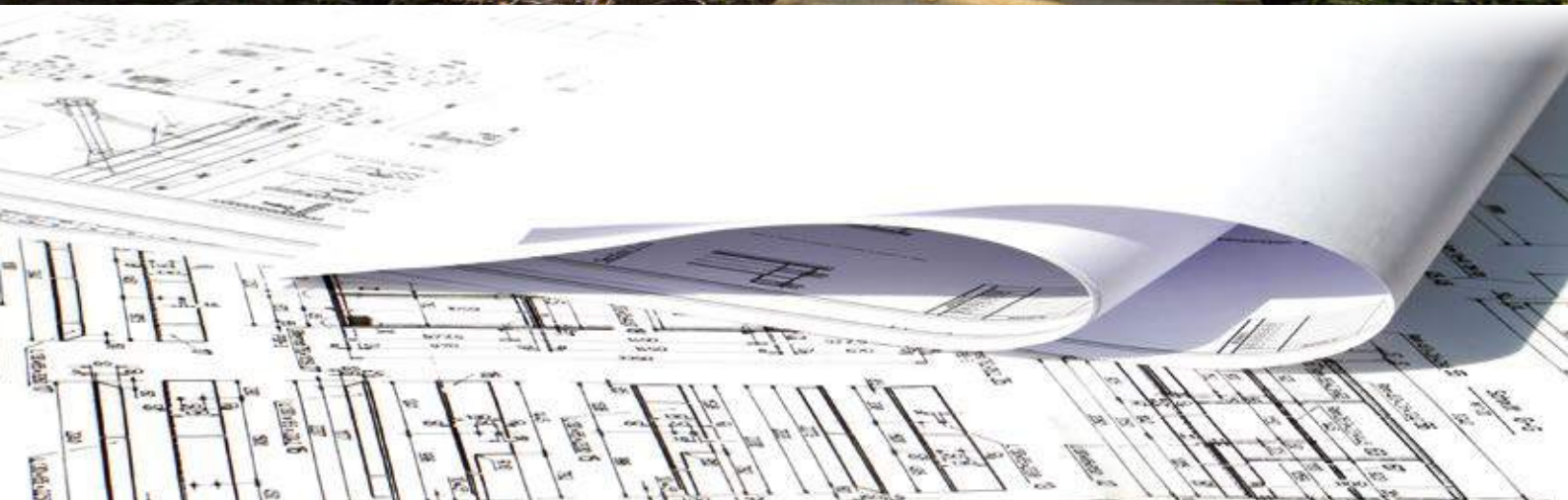

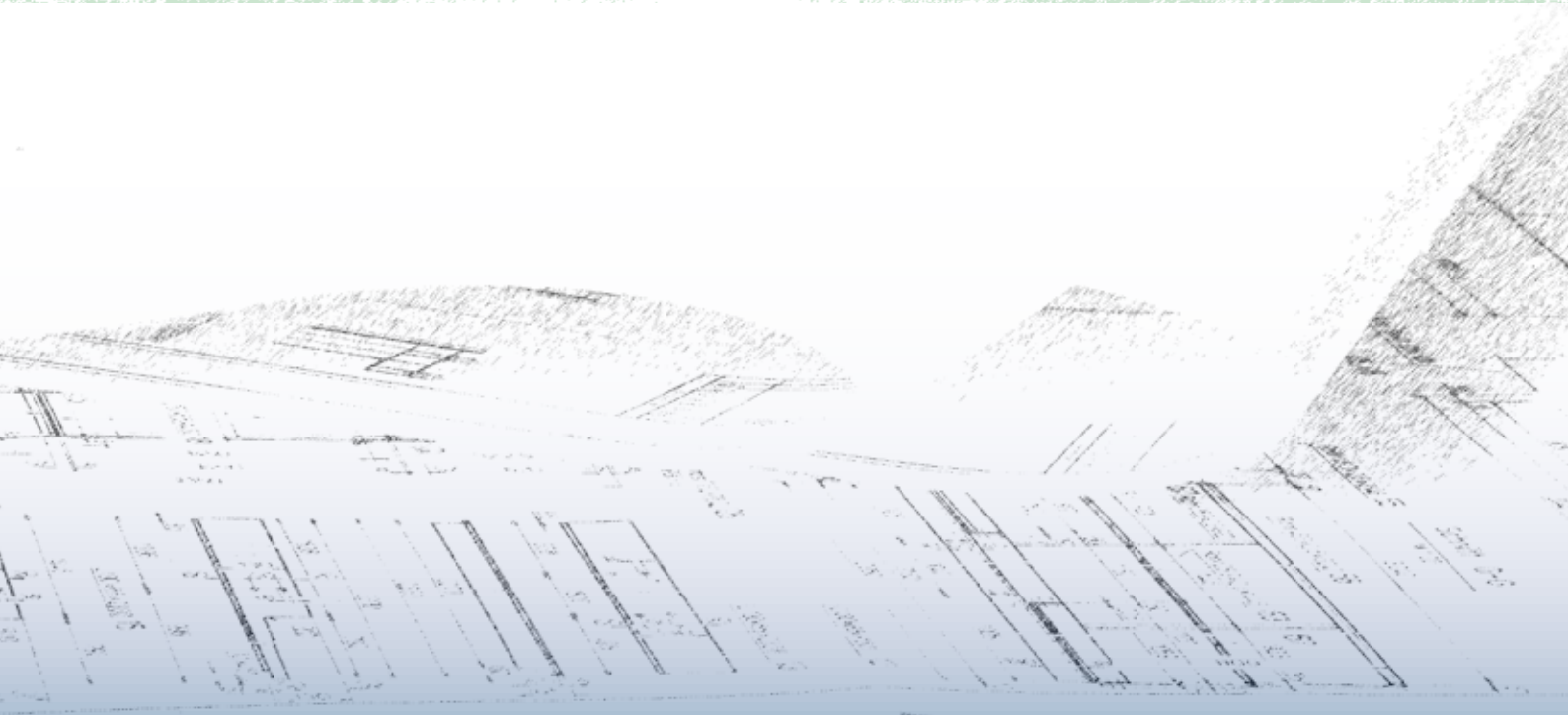

HITEMA^{international} is a specialist manufacturer of sustainable solutions for process cooling and comfort applications. Since its beginning over 25 years ago, **HITEMA**^{international} has grown, selling worldwide, becoming a leading specialist in temperature equipment. We supply high quality products as well as tailor made solutions according with Customer request.



HITEMA^{international} ist als Hersteller darauf spezialisiert, nachhaltige Lösungen im Bereich von Prozesskühlung und Komfortklimatisierung anzubieten. Seit seiner Gründung vor über 25 Jahren, ist **HITEMA**^{international} zu einem weltweit agierenden Spezialisten im Bereich der Temperiergeräte gewachsen, der Hightech-Produkte nach Kundenwunsch maßgeschneidert ausführt.

HITEMA^{international} IN NUMBERS

45 employees and 23 ranges of products with 4 production plants with a total of 18.750 m² of indoor space. The sales **HITEMA**^{international} network has a presence in over 45 Countries throughout the World.

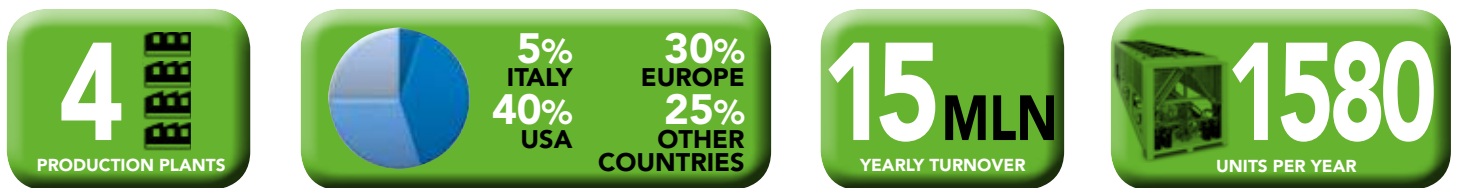

HITEMA^{international} IN ZAHLEN

45 Mitarbeiter und 23 Produktreihen, 4 Produktionen mit einer gesamten Produktionsfläche von 18.750 m². Das **HITEMA**^{international} Vertriebsnetz ist weltweit in über 45 Ländern präsent.

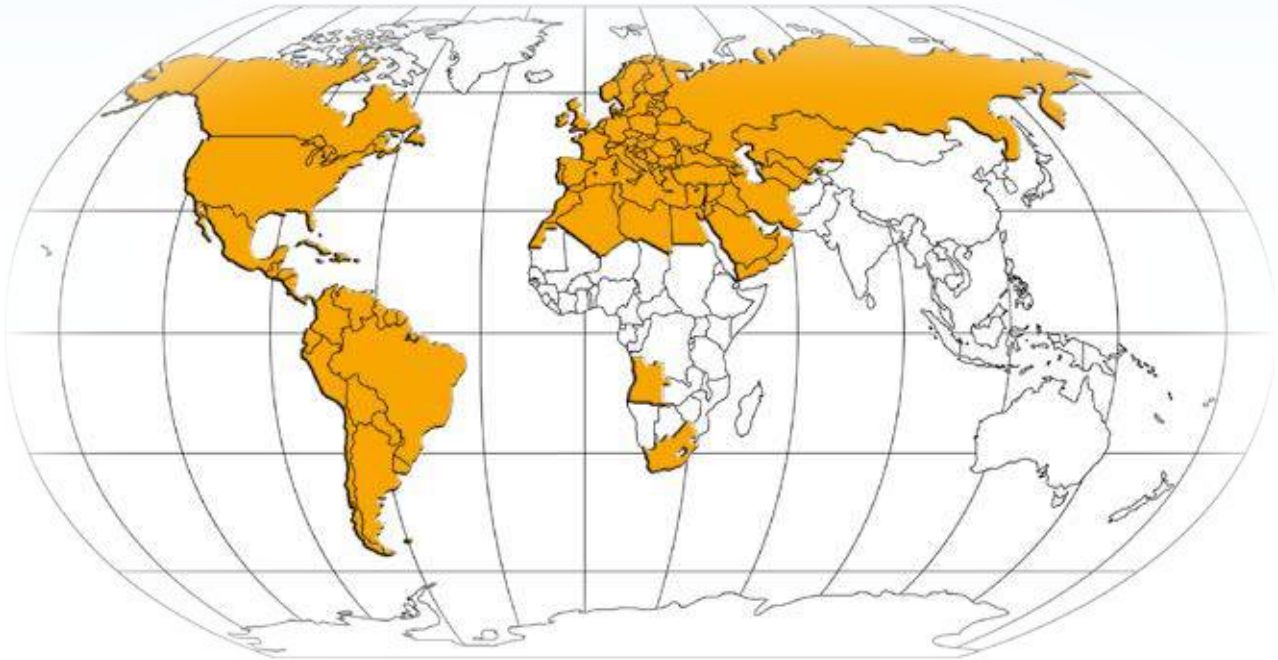

Areas covered by the **HITEMA[®] Service net**
For any needs contact our sales department

Gebiete die das **HITEMA[®] Servicenetz abdeckt werden**
Für weitere Informationen wenden Sie sich bitte
an unseren Vertrieb.



international

Our focus is on keeping Customers' businesses running 100% efficiently and reliably



Unser Fokus ist es, die Anwendungen unserer Kunden 100% effizient und zuverlässig zu gestalten

HFC Refrigerants



HFO Refrigerants



Natural Refrigerants





PROCESS COOLING APPLICATION SERIES

ENR Series, air-cooled liquid chillers with axial fans. Cooling capacity 1,6÷410kW.

ENRF Series, free-cooling liquid chillers with axial fans. Cooling capacity 23÷355kW.

CSE Series, air-cooled liquid chillers with centrifugal fans. Cooling capacity 30÷377kW.

PROZESSKÜHLUNG ANWENDUNG SERIE

Serie ENR, luftgekühlte Flüssigkeitsabkühler mit Axialventilatoren. Kälteleistung 1,6÷410kW.

Serie ENRF, freikühlende Flüssigkeitsabkühler mit Axialventilatoren. Kälteleistung 23÷355kW.

Serie CSE, luftgekühlte Flüssigkeitsabkühler mit Radialventilatoren. Kälteleistung 30÷377kW.

PROCESS COOLING APPLICATION SERIES

ENR - ENRF - CSE

Page	TECHNICAL SPECIFICATIONS	Seite	TECHNISCHE DATEN
8	1 General description	8	1 <i>Allgemeine Beschreibung</i>
9	2 Frame and Covering	9	2 <i>Rahmen und Abdeckungen</i>
10	3 Compressors	10	3 <i>Kompressoren</i>
10	4 Evaporator	10	4 <i>Verdampfer</i>
12	5 Condenser Coil	12	5 <i>Verflüssiger</i>
13	6 Fans	13	6 <i>Ventilatoren</i>
14	7 Refrigeration Circuit	14	7 <i>Kältekreislauf</i>
15	8 Hydraulic Circuit	15	8 <i>Hydraulikkreislauf</i>
17	9 Integrated Free-Cooling (only ENRF series)	17	9 <i>Integrierte Freikühlung (ausschließlich bei Serie ENRF)</i>
18	10 Electric Panel	18	10 <i>Elektrische Schalttafel</i>
18	11 Control and Safety Devices	18	11 <i>Steuer - und Sicherheitsvorrichtungen</i>
19	12 Electronic Control	19	12 <i>Elektronische Steuerung</i>
21	13 Testing	21	13 <i>Überprüfung</i>
22	14 Main options	22	14 <i>Hauptauswahl</i>
30	15 Technical data	30	15 <i>Technische Daten</i>
36	16 Working limits	36	16 <i>Arbeitsgrenzen</i>
50	17 Table Standard/Option/Not Available	50	17 <i>Datenblatt mit Optional (Standard/optional/nicht verfügbar)</i>
68	18 Dimensional drawings	68	18 <i>Maßzeichnungen</i>
80	19 Installation Guide	80	19 <i>Installationsanleitung</i>
80	20 Unit packing	80	20 <i>Verpackung der Einheit</i>

1 General description

ENR, ENRF, CSE SERIES are aircooled liquid chillers, designed for industrial use and for outdoor (ENR, ENRF) and indoor (CSE) installation. These chillers are designed for applications that require reliability, continuity of operation, high performance and reduced management costs.

ENR SERIES /air cooled; axial fans; brazed plate or coaxial or shell & tube evaporator; rotary-scroll compressors; finned coil condenser; cooling capacity from 1,6kW to 410kW (at the conditions water outlet +7°C, water inlet +12°C, ambient temp. +35°C, ff = 0,000043 m² K/W).

ENRF SERIES /air cooled with integrated freecooling; axial fans ; coaxial or shell & tube evaporator ; scroll compressors; finned coil condenser; cooling capacity from 23.4kW to 355kW (at the conditions water outlet +7°C, water inlet +12°C, ambient temp. +35°C, ff = 0,000043 m² K/W).

CSE SERIES /air cooled with centrifugal fans; coaxial or shell & tube evaporator; scroll compressors; finned coil condenser; cooling capacity from 30kW to 377kW (at the conditions water outlet +7°C, water inlet +12°C, ambient temp. +32°C, ff = 0,000043 m² K/W).

All the models are equipped with coaxial or shell and tube evaporator (at exception models 001÷002) that ensures reliable operation in particular with liquids containing impurities. All the models are equipped with water pump suitable to work with water-glycol mixture and storage tank to assure precise control of temperature even in the presence of highly variable thermal loads from the process.

With the wide range of cooling capacity up to 440kW it is possible to satisfy all customer demands. The refrigerant used is R410A. The chillers are provided with one (models 001÷100) or two (models 130÷480) refrigerant circuits with up to 2 compressors per circuit to ensure high efficiency also at partial load.

The degree of electrical protection is IP54 for all the models (IP44 for CSE 130÷370) and thanks also to the evaporators coaxial and shell & tube technology it is possible to ensure high performances and reliability of the units in all the industrial applications. It is recommended to install a suitable water filter on the inlet. At the end of the assembly process, 100% of the units are tested in a dedicated testing area inside Hitema factory. In this way we can guarantee to our Customers the respect of required performances, reliability and continuity of operation also in the most demanding working conditions.

One of several advantages of the series **ENR ENRF** and **CSE** is their footprint: the series are designed to take up minimal floor space which also reduces shipment costs.

1 Allgemeine Beschreibung

SERIE ENR, ENRF, CSE sind luftgekühlte Flüssigkeitskühler für den industriellen Gebrauch zur Außenmontage (ENR, ENRF) und Innenmontage (CSE). Diese Kühler sind für alle Anwendungen entworfen worden, die Zuverlässigkeit, Leistungskontinuität, Hochleistung und reduzierte Managementkosten verlangen.

SERIE ENR / luftgekühlt; Axialventilatoren; gelötete Platten-Koaxial - Rohrbündelverdampfer; Scroll-Rotationsverdichter; Kondensator mit gerippten Aluminium-Lamellen; Kühlleistung von 1,6kW bis 410kW (bei diesen Bedingungen Wasseraustritt +7 °C _ Wassereinlass +12 °C, Umgebungstemp. +35°C, ff = 0,000043 m² K/W).

SERIE ENRF / Luftgekühlt mit integrierter Freikühlung; Axialventilatoren; Koaxial - Rohrbündelverdampfer; Scroll-Rotationsverdichter; Kondensator mit gerippten Aluminium-Lamellen; Kühlleistung von 23,4kW bis 355kW (bei diesen Bedingungen Wasseraustritt +7°C _ Wassereinlass +12°C, Umgebungstemp. +35°C, ff = 0,000043 m² K/W).

SERIE CSE / luftgekühlt mit Zentrifugallüfter; Koaxial - Rohrbündelverdampfer; Scroll-Rotationsverdichter; Kondensator mit gerippten Aluminium-Lamellen; Kühlleistung von 30kW bis 377kW (bei diesen Bedingungen Wasseraustritt +7°C Wassereinlass +12°C, Umgebungstemp. +32°C, ff = 0,000043 m² K/W).

Alle Modelle sind mit einem Koaxial- oder Rohrbündelverdampfer ausgestattet (außer den Modellen 001÷002), um eine zuverlässige Kühlleistung vor allem bei verunreinigten Flüssigkeiten zu gewährleisten. Alle Modelle sind mit einer Wasserpumpe, die für Wasser-Glykol-Mischungen geeignet ist, und einem Speichertank, um eine präzise Temperaturkontrolle auch bei stark unterschiedlichen Wärmeladungen durch das Verfahren zu gewährleisten, ausgerüstet.

Mit der umfangreichen Kühlkapazität von bis zu 440kW ist es möglich, sämtliche Kundenwünsche zu erfüllen. Das verwendete Kühlmittel ist R410A. Die Kühler sind mit einem (Modelle 001÷100) oder zwei (Modelle 130÷480) Kühlmittelkreisläufen mit bis zu 2 Verdichtern pro Kreislauf ausgestattet, um eine hohe Leistung auch bei Teillast zu gewährleisten.

Der Grad an elektrischem Schutz ist für alle Modelle IP54 (IP44 für CSE 130÷370), und dank der koaxialen und Rohrbündel-Technologie der Verdampfer ist es möglich, hohe Leistungen und Zuverlässigkeit der Geräte für sämtliche industrielle Anwendungen zu gewährleisten. Sämtliche Geräte werden in den Hitema Produktionsstätten vor dem Versand überprüft, um den Kunden die besten Leistungen, Zuverlässigkeit und Kontinuität des Betriebs zu gewährleisten. Es wird empfohlen, einen geeigneten Filter auf der Wassereinlassseite des Gerätes einzubauen. Einer der vielen Vorteile der Serien **ENR, ENRF** und **CSE** sind die Geräteabmessungen. Die Serie ist entwickelt worden, um am Montageort eine kleinstmögliche Stellfläche einzunehmen und die Frachtkosten zu reduzieren.

Power Supply:

230V/1ph/50Hz (models 001÷005)
 400V/3ph+N/50Hz (models 008÷018)
 400V/3ph/50Hz (models 022÷480)
 60Hz available on request
 UL certification available on request

ENR, ENRF and **CSE** are manufactured in compliance with the European Community Directives:
 Electromagnetic Compatibility Directive 2014/30/UE;
 Machine Directive 2006/42/CE;
 Pressure equipment Directive 2014/68/UE (PED);
 Low voltage Directive 2014/35/UE

References to harmonized standards :

EN 60204-1:2006+A1:2009
 EN 55014-2:1997+A1:2001+A2:2008
 EN 378-2:2016

The chiller name is defined as follows:
 [series].[model]/[configuration]

Where:

series: **ENR, ENRF** or **CSE**

model: chiller model number based on the cooling capacity
 configuration: list of features and options included (at the conditions water outlet +7°C, water inlet +12°C, ambient temp. +35°C, ff = 0,000043 m² K/W please refer to chapter 15 "Main options")

eg.: ENR.130/CST.ST.WP.RV

It is an aircooled chiller from ENR series, model 130, with tank in carbon steel (CST), shell and tube evaporator (ST), pump with nominal pressure head 3 barg (WP), cut-phase electronic fan speed control (RV).

2 Frame and Covering

The structure is specifically designed for outdoor installation. All the models are characterized by strong self-supporting frame and sheet panels that can be easily removed for maintenance and repairs operations.

Frame and panels in carbon steel sheet (galvanized for models 030÷480 and all the ENRF series) with epoxy polyester-powder coating (RAL 7035 as standard, other RAL colours on request) providing excellent weatherproofing and resistance to corrosion.

On request for models ENR.030÷100 it is possible to add a panel to separate refrigerating and electrical section from hydraulic and condenser section, that allows easy chiller calibration and maintenance (PAN option).

On request it is also available the version with frame in stainless steel AISI 430 for all the models of all the series.

Stromversorgung:

230V/1ph/50Hz (Modelle 001÷005)
 400V/3ph+N/50Hz (Modelle 008÷018)
 400V/3ph/50Hz (Modelle 022÷480)
 60Hz auf Nachfrage
 UL-Zulassung auf Nachfrage

Die standardmäßigen Produktserien **ENR, ENRF, CSE** werden in Übereinstimmung mit den Richtlinien der Europäischen Gemeinschaft hergestellt:
 Richtlinie 2014/30/EU - Elektromagnetische Verträglichkeit;
 Maschinenrichtlinie 2006/42/CE;
 Druckgeräterichtlinie 2014/68/EU (PED);
 Niederspannungsrichtlinie 2014/35/EU

Verweise auf harmonisierte Normen:

EN 60204-1:2006+A1:2009
 EN 55014-2:1997+A1:2001+A2:2008
 EN 378-2:2008+A2:2012

Die Kühlerbezeichnung setzt sich aus den folgenden Angaben zusammen:

[Serie].[Modell]/[Konfiguration]

Wobei:

Serie: **ENR, ENRF, CSE**

Modell: Kühler Modellnummer auf Basis der Kühlleistung
 Konfiguration: Liste der Merkmale einschließlich der optionalen Ausrüstungen (Die Beschreibung der Merkmale und Optionals, bitte im Kapitel 15 "Hauptoptionen" nachlesen)
 Z.B.: ENR.130/CST.ST.WP.RV

Ist ein luftgekühlter Kühler der ENR Serie, Modell 130, mit Tank aus Kohlenstoffstahl (CST), Rohrbündelverdampfer (ST), Pumpe mit nominaler Druckhöhe von 3 bar/Ü (WP) und nach dem Phasenanschnittsprinzip funktionierende elektronische Lüftergeschwindigkeitskontrolle (RV).

2 Rahmen und Abdeckungen

Die Geräte sind extra für die Außenmontage entworfen worden. Alle Modelle sind durch einen starken selbsttragenden Rahmen und Blechtafeln charakterisiert, die einfach abgenommen werden können, um an den Kühler für Wartungs- und Reparaturarbeiten zu kommen.

Rahmen und Tafeln aus Kohlenstoffstahlblech (verzinkt bei den Modellen 030÷480) und allen Modellen der ENRF-Serie mit Epoxyd-Polyesterpulverbeschichtung (RAL 7035 als Standard, andere RAL auf Nachfrage) bieten einen hervorragenden Witterungsschutz und Korrosionsbeständigkeit.

Für die Modelle ENR 030÷100 kann auf Wunsch eine Tafel zusätzlich angebracht werden, um den Kühl- und Elektroteil von dem Hydraulik- und Kondensatorteil zu trennen, sodass der Kühler leicht kalibriert und gewartet werden kann (Optional PAN).

Auf Wunsch ist auch die Version mit Rahmen in Edelstahl AISI 430 für alle Modelle aller Serien.

3 Compressors

Hermetic orbiting scroll compressors (except for ENR.001÷005, in this range hermetic rotary compressors are used) complete with:

- individual contactor
- thermal protection against overheating (internal or Klixon or electronic based on the compressor model)
- thermal circuit breaker against overcurrent and short circuit (from model 008)
- oil sight glass (from model 030)
- crankcase heater to ensure proper lubrication even with low ambient temperature (standard from model 008)
- rubber anti-vibration dampers.

From model 061 the chillers are equipped with two compressors connected in parallel for each refrigerant circuit (twin configuration), this configuration allows high efficiency at partial load and unloading function (the unloading function allows the chiller to work in high ambient temperature preventing the high pressure alarm, for the unloading function please contact our sales department).



With twin configuration the compressors of each refrigerant circuit are mounted on a pair of steel rails and the resulting assembly is installed on rubber anti-vibration dampers, the compressors are connected with oil-equalizing line.

4 Evaporator

Models 001 and 002 are equipped with AISI316 stainless steel brazed welded plate evaporator.

Models 003÷100 are equipped with open type self-cleaning coaxial evaporator.

Models 130÷480 are equipped with shell and tube evaporator.

Coaxial evaporator is characterized by compact design, it consists in a convoluted tube in tube exchanger (outer tube in carbon steel, inner tubes in copper) installed inside the water storage tank, the evaporator cools the process fluid that flows in countercurrent with the refrigerant fluid evaporating inside the copper tubes.

Shell&Tube evaporators are made by carbon steel (shell) and copper (tubes).

Coaxial and Shell&Tube evaporators are designed for industrial application and ensure a high level of reliability also with liquids containing impurities.

High efficiency is guaranteed with all evaporators thanks

3 Kompressoren

Luftdichte Scroll-Umlaufverdichter (außer bei den Modellen ENR 001÷005), in diesem Bereich werden luftdichte Scroll-Rotationsverdichter eingesetzt) komplett mit:

- Individueller Kontaktschalter
- Thermischer Schutz gegen Überhitzung (intern oder Klixon oder elektronisch auf dem Kompressormodell)
- Thermischer Leistungsschalter gegen Überstrom und Kurzschluss (bei Modell 008)
- Ölstandsichtglass (von Modell 030)
- Kurbelgehäuseheizung, um eine korrekte Schmierung auch bei niedriger Umgebungstemperatur (standardmäßig ab Modell 008)
- zu gewährleisten Gummi-Vibrationsdämpfer

Beim Modell 061 sind die Kühler mit zwei parallelgeschalteten Verdichtern für jeden Kühlmittelkreislauf (Twin-Konfiguration) ausgestattet, diese Konfiguration erlaubt eine hohe Leistung in der Teillast - oder Entlastungsfunktion (die Entlastungsfunktion erlaubt dem Kühler bei hohen Temperaturen zu arbeiten, ohne dass der Überdruckalarm ausgelöst wird, für die Entlastungsfunktion wenden Sie sich bitte an unsere Verkaufs-

abteilung).

Bei der Twin-Konfiguration werden die Verdichter jedes Kühlmittelkreislaufs auf ein Paar Stahlschienen montiert, die Gruppe wird dann auf Gummivibrationsdämpfer montiert, zum Schluss werden die Verdichter an eine Ölrücklaufleitung angeschlossen.

4 Verdampfer

Die Modelle 001 und 002 sind mit gelöteten Platten-Verdampfern aus AISI316 Stahl ausgerüstet.

Die Modelle 003÷100 sind mit offenen selbstreinigenden Koaxialverdampfern ausgerüstet.

Die Modelle 130÷480 sind mit Rohrbündelverdampfern ausgerüstet.

Koaxialverdampfer haben ein kompaktes Design und bestehen aus einem gebogenen Rohr-in-Rohr-Wärmeaustauscher (das äußere Rohr ist aus Kohlenstoffstahl, die inneren Rohre aus Kupfer), der in einen Wasserspeichertank eingebaut ist, der Verdampfer kühlt die Prozessflüssigkeit, die in die entgegengesetzte Richtung der Kühlmittelflüssigkeit, die in die Kupferrohre verdampft, fließt.

Rohrbündelverdampfer sind aus Kohlenstoffstahl hergestellt (Außenmantel) und Kupfer (Innenrohre).

Die Koaxial- und Rohrbündelverdampfer sind für die industrielle Anwendung entworfen und garantieren eine hohe Zuverlässigkeit auch bei verunreinigten Flüssigkeiten.

Hohe Leistung wird bei allen Verdampfern garantiert dank

to countercurrent flow between water and refrigerant and optimized distribution system to allow uniform refrigerant flow.

All the chillers are provided with antifreeze protection against the risk of freezing caused by low evaporation temperature. All evaporators are compliant with CE-PED (ASME on request).

der Gegenströmung zwischen Wasser und Kühlmittel und dem optimierten Verteilungssystem, das einen einheitlichen Kühlmitteldurchfluss erlaubt.

Alle Kühler sind mit einem Frostschutz gegen das Gefrierisiko, das bei niedrigen Verdampfungstemperaturen besteht, ausgerüstet. Alle Verdampfer entsprechen den CE-PED -Anforderungen (ASME auf Nachfrage).

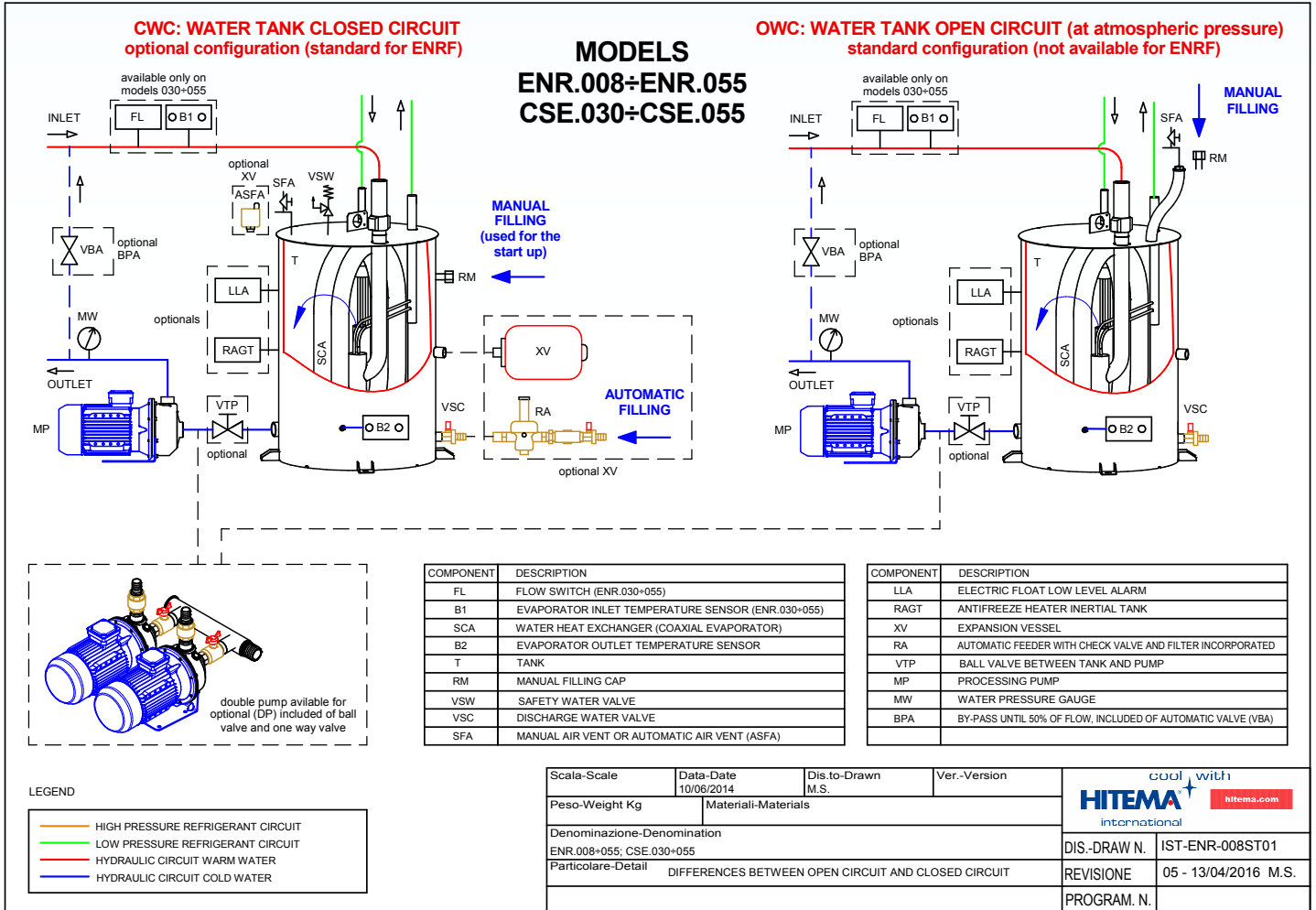

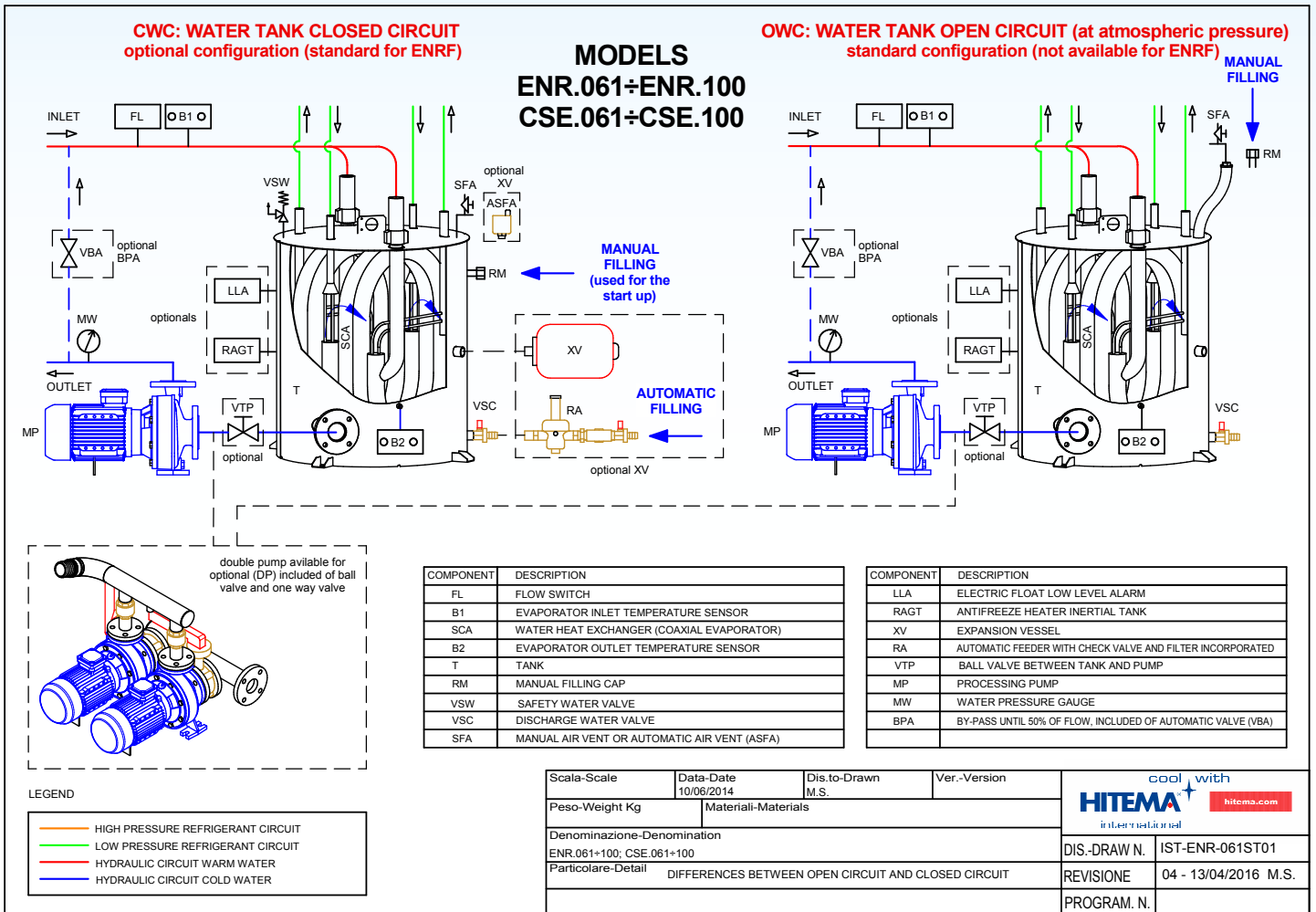

Copyright-Nachdruck verboten

5 Condenser Coil

Finned coil heat exchanger consisting of tubes and manifolds in copper, corrugated fins in aluminium, and shoulders in galvanized sheet metal. Fin and tube condenser coils are manufactured using corrosion resistant copper tubes arranged in staggered rows and mechanically expanded into corrosion resistant aluminum alloy fin collars. The design working pressure is 45bar and each coil is pressure tested to 49,5bar. These exchangers, designed utilising the latest technology, are optimized to achieve the maximum heat rejection capacity in the smallest unit footprint and allow the use of reduced fan speeds. All the chillers are provided as standard with galvanized grid for mechanical protection of the condenser coil. As an alternative the chillers can be provided with condenser aluminum mesh air filter. As option it is possible to protect the condenser against chemical corrosion (in case of heavy industrial application and coastal atmosphere) using epoxy coating (CV option), Silver Line coating (CG option), or copper fins (CC option) depending on the corrosiveness of the atmosphere.

5 Verflüssiger

Die Wärmeaustauscher mit Verflüssigern aus gerippten Aluminium-Lamellen bestehen aus Kupferrohren und Kupferrohrträger, gewellten Blechen aus Aluminium und Schultern aus verzinkten Stahlsträngen. Lamellen- und Rohrverflüssiger werden aus korrosionsbeständigen, in versetzten Reihen angeordneten Kupferrohren, die mechanisch in korrosionsbeständige Rippenkragen mit Aluminiumlegierung erweitert werden, hergestellt. Der Arbeitsdruck für das Design beträgt 45bar und jeder Verflüssiger ist auf einen Druck von 49,5bar getestet worden. Die Austauscher, die mit der neusten Technologie entwickelt worden sind, sind optimiert worden, um die höchste Abstoßungsfähigkeit in der kleinsten Fußabdruckeinheit zu erhalten und um geringere Lüftergeschwindigkeiten zu erlauben. Alle Kühler werden standardmäßig mit verzinktem Gitter als mechanischer Schutz für den Verflüssiger ausgerüstet. Alternativ können die Kühler mit Aluminiumnetz-Luftfilter für den Kondensator geliefert werden. Als weitere Option kann eine Epoxyd-Beschichtung (Option CV), Silver Line Beschichtung (Option CG) oder Kupferrippen (Option CC) je nach der Korrosivität der Atmosphäre verwendet werden, um den Kondensator gegen chemische Korrosion zu schützen (bei Schwerindustrieanwendungen und Küstenklima).

6 Fans

ENR Series / Axial fans with sickle-shaped blades directly coupled to 4 or 6-pole electric motor. Standard fan control is ON/OFF type managed by pressure switches for models 008÷185, for models 200÷480 the control of the rotation speed is continuous (cut-phase) depending on the condensation pressure.

ENRF Series / Axial fans with sickle-shaped blades directly coupled to 4 or 6-pole electric motor. Standard control of the rotation speed is continuous (cut-phase) depending on the condensation pressure for all the models.

For **ENR** and **ENRF** series the fans are statically and dynamically balanced. They confirming CE. The protection rating is IP54 with insulation class F in order to ensure outdoor operation in all climatic conditions. Fans are protected against overload by thermal circuit breaker. Thanks to the new diffuser design, a large part of the dynamic airflow energy is converted into static pressure. This greatly improves efficiency making it possible to reduce operating speed and noise level. It is possible to protect the serviceman from injuries during maintenance operation adding an internal fan guard (IFG option), this option is not available for ENR.001÷022 because these models are provided with conveyed condenser.

CSE Series / Centrifugal fans with forward curved impeller directly coupled to 6 or 8-pole electric motor. These fans allow the client to install on the chiller air ducts with pressure drop up to 200Pa at the nominal air flow rate. Standard fan control is ON/OFF type managed by pressure switches for models 030÷100, for models 130÷370 the control of the rotation speed is continuous (inverter) depending on the condensation pressure. Fans are conforming to CE, statically and dynamically balanced. Fans are protected against overload by thermal circuit breaker. The advantages of these



6 Ventilatoren

SERIE ENR / Axialventilatoren mit sichelförmigen Blättern direkt an 4- oder 6-poligem Elektromotor gekoppelt. Die Standard-Ventilatoren-Steuerung für die Modelle 008÷185 ist von ON/OFF-Typ, die über Druckschalter gesteuert werden, für die Modelle 200÷480 ist die Steuerung der Drehgeschwindigkeit in Abhängigkeit vom Kondensationsdruck fortlaufend (Phasenanschnittsteuerung).

SERIE ENRF / Axialventilatoren mit sichelförmigen Blättern direkt an 4- oder 6-poligem Elektromotor gekoppelt. Die Standardsteuerung der Drehgeschwindigkeit ist bei allen Modellen in Abhängigkeit vom Kondensationsdruck fortlaufend (Phasenanschnittsteuerung).

Die Ventilatoren der **ENR** und **ENRF**-Bauserien entsprechen den EG-Anforderungen, sind statisch und dynamisch ausgewuchtet und komplett mit Schutzgittern ausgestattet. Die Schutzart ist IP54 mit Isolationsklasse F, wodurch der Betrieb im Freien unter allen Klimabedingungen gewährleistet wird. Die Ventilatoren sind durch Thermoschutzschalter gegen Überlast geschützt. Dank des neuen Diffuser-Designs wird ein Großteil der dynamischen Luftstromenergie in statischen Druck umgewandelt. Hierdurch wird die Effizienz verbessert und somit die Betriebsgeschwindigkeit sowie der Rauschpegel verringert. Es ist möglich, die Soldaten vor Verletzungen während der Wartungsvorgang das Hinzufügen einer internen Lüfterhaube (optional IFG) zu schützen, dies optional ist für ENR.001 ÷ 022 nicht verfügbar, da diese Modelle mit Förderkühler.

SERIE CSE / Zentrifugalventilatoren mit vorwärts gebogenem Flügelrad direkt an 6- oder 8-poligem Elektromotor gekoppelt. Diese Ventilatoren ermöglichen dem Kunden, an den Kühler Lüftungskanäle mit einer Druckabnahme bis zu 200Pa bei der nominalen Luftdurchflussrate einzubauen. Die Standard-Ventilatoren-Steuerung für die Modelle 030÷100 ist von ON/OFF-Typ, die über Druckschalter gesteuert werden, für die Modelle



fans are: maintenance free, no transmission losses, long fan life time, high reliability, low operating costs.



130÷370 ist die Steuerung der Drehgeschwindigkeit in Abhängigkeit vom Kondensationsdruck fortlaufend (Umrichter). Die Ventilatoren entsprechen den EG-Anforderungen und sind statisch und dynamisch ausgewuchtet. Die Ventilatoren sind durch Thermoschutzschalter gegen Überlast geschützt. Die Vorteile dieser Ventilatoren sind: wartungsfrei, keine Übertragungsverluste, lange Lebensdauer, hohe Zuverlässigkeit, niedrige Betriebskosten.

7 Refrigeration Circuit

Each chiller is provided with one (for mod. 001÷100) or two (for mod. 130÷480) completely independent refrigerant circuits for high reliability.

The refrigeration circuit is made in copper pipes and includes following components:

- Mechanical thermostatic expansion valve with external equalization (at exception of models 001÷005 where a capillary tube is used) to manage the refrigerant flow according to the thermal load and to ensure the suitable superheating of the gas on the suction side in all operating conditions.
- (Interchangeable for mod. 061÷480) Filter-drier
- Solenoid valve (for mod. 008÷480)
- Liquid and humidity indicator (for mod.030÷480)
- High pressure switch (standard for mod.008-480)
- Low pressure switch (standard for mod.030÷480)
- High pressure safety valve (standard for mod.061÷480)
- Low pressure safety valve (standard for mod.230÷480)
- High pressure gauges (standard from mod.061, HPG option for mod.003÷055)
- Low pressure gauges (standard from mod.030, LPG option for mod.003÷022)
- Shut-off valves on suction and discharge lines (CSV option, available for mod.008÷480)
- Schrader service valves
- Insulation of low pressure line

7 Kältekreislauf

Jeder Kühler ist mit einem (für die Modelle 001÷100) oder zwei (für die Modelle 130÷480 komplett unabhängigen Kühlkreisläufen für eine hohe Zuverlässigkeit ausgerüstet.

Der Kältekreislauf vollzieht sich in Kupferrohren und enthält folgende Komponenten:

- Mechanisches thermostatisches Expansionsventil mit externem Ausgleich (mit Ausnahme der Modelle 001÷005, bei denen ein Kapillarschlauch verwendet wird), um den Kühlmitteldurchfluss gemäß der Wärmelast zu steuern und um die geeignete Überhitzung des Gases auf der Einlassseite bei allen Betriebsbedingungen zu gewährleisten
- (Austauschbare für Mod. 061 ÷ 480) Filtertrockner
- Magnetventil (für Mod. 008 ÷ 480)
- Flüssigkeits- und Feuchtigkeitsindikator (für Mod. 030 ÷ 480)
- Hochdruckschalter (standardmäßig für Mod. 008 ÷ 480)
- Niederdruckschalter (standardmäßig für Mod. 030 ÷ 480)
- Hochdruckschalter (standardmäßig für Mod. 061 ÷ 480)
- Niederdruck-Sicherheitsventil (standardmäßig für Mod. 230÷480)
- Hochdruckmessgeräte (standardmäßig von Mod. 061, optional für Mod. 003 ÷ 055)
- Niederdruckmessgeräte (standardmäßig von Mod. 030, optional für Mod. 003 ÷ 022)
- Absperrventil an den Einlass- und Ablassleitungen (Optional CSV verfügbar für die Modelle 008 ÷ 480)
- Schraderventile
- Isolierung der Niederdruckleitung

8 Hydraulic Circuit

The hydraulic circuit is made in carbon steel as standard, with coaxial evaporator (models 003÷100) or shell and tube evaporator (models 130÷480) and rubber piping. For models 001 ÷ 002 the hydraulic circuit is made in Stainless steel and copper with plate evaporator. All the models are equipped with inertial storage tank (for models with coaxial evaporator it contains the evaporator) and pump with nominal pressure head 3 barg.

Models 030÷480 and ENRF series are provided as standard with flow switch to shut-down the unit in case of insufficient water flow.

Connections between rubber piping and manifolds are guaranteed by hose holders and special designed clamps in order to avoid loosening of rubber hoses, this type of connection ensures high reliability and easy maintenance.

All the models are complete with water connections up to the edge of the chiller (threaded type mod.001÷100; flanged type mod.130÷480)

The hydraulic circuit is insulated with 10mm insulating material (19mm with LW option)

TANK:

Hydraulic storage tank, in carbon steel as standard, assures optimum precision in the control of temperature even in the presence of highly variable thermal loads from the user avoiding frequent ON/OFF cycles which are detrimental to the lifetime specially of the compressors. The tank is designed for a maximum working pressure of 3 barg.

Models ENR.001÷100 and CSE.030÷100 are designed to work in an open water circuit: the tank is provided with transparent plastic pipe for air vent and manual filling from the top of the unit. The water level contained into the tank can be easily monitored looking at this transparent plastic pipe visible on the unit covering, with this unit design it is not necessary to add any external plastic tank which can be easily subject to breakage. Models 008÷100 can work also in a closed water circuit as option (CWC) with 3barg safety valve and manual air vent.

Models ENR.130÷480, CSE.130÷370, ENRF. 022÷370 are designed to work in a closed water circuit: the tank is provided with 3barg safety valve and manual air vent. With closed water

8 Hydraulikkreislauf

Der Hydraulikkreislauf ist standardmäßig aus Kohlenstoffstahl, mit Koaxialverdampfer (Modelle 003÷100) oder Rohrbündelverdampfer (Modelle 130÷480) und Gummischlauch. Für Modelle 001÷002 der Hydraulikkreislauf ist aus rostfreien Stahe und Kupfer mit Plattenverdampfer. Alle Modelle sind mit Trägheitsspeicher (für Modelle mit Koaxialverdampfer enthält er den Verdampfer) und Pumpen mit nominaler Druckhöhe von 3 bar/Ü.

Modelle 030÷480 und die Modelle der ENRF-Serie sind standardmäßig mit einem Durchflusswächter ausgestattet, um das Gerät bei ungenügendem Wasserdurchfluss abzustellen.

Feste Verbindungen zwischen dem Gummischlauch und den Anschlussstücken werden durch Schlauchhalter und spezielle Klammern gewährleistet, um zu verhindern, dass die Gummischläuche sich lösen, dieser Verbindungstyp gewährleistet eine hohe Zuverlässigkeit und einfache Wartung.

Alle Modelle sind komplett mit Wasseranschlüssen bis zum Rand des Kühlers (mit Gewinde-Modell 001÷100; angeflanscht Modell 130÷480).

Der Hydraulikkreislauf ist mit 10mm Isoliermaterial (19 mm mit dem optionalen LW) isoliert.

TANK:

Der Hydraulik-Speichertank, standardmäßig aus Kohlenstoffstahl, gewährleistet eine optimale Genauigkeit bei der Temperaturkontrolle, sogar bei sehr variablen thermischen Belastungen, wodurch häufige EIN/AUS-Zyklen, die nachteilig für die Lebensdauer vor allem der Kompressoren sind, vermieden werden. Der Tank ist für einen maximalen Arbeitsdruck von 3 bar/Ü entworfen.



Die Modelle ENR.001÷100 und CSE.030÷100 sind entwickelt worden, um in einem offenen Wasserkreislauf zu arbeiten: Der Tank ist mit durchsichtigen Kunststoffrohren für die Entlüftung ausgestattet und kann von oben mit der Hand aufgefüllt werden. Die im Tank enthaltene Wassermenge kann leicht überwacht werden, indem das transparente Kunststoffrohr beobachtet wird, das auf der Geräteabdeckung sichtbar ist. Mit diesem Gerätedesign ist es nicht notwendig, einen externen Kunststofftank hinzuzufügen, der leicht brechen kann. Die Modelle 008÷100 können in einem geschlossenen Wasserkreislauf (Optional CWC) mit einem 3 bar/Ü Sicherheitsventil und manueller Entlüftung arbeiten.

circuit configuration the option XV can be added, it includes expansion vessel, automatic filling system and automatic air vent.

For all the models the tank is equipped with a drain valve to allow the tank to be emptied.

The tank can be equipped with low level switch (LLA option, available on request) to shut-down the unit if an insufficient water level is detected and with antifreeze immersion heater (RAGT option, on request, available from model 008). In Stainless steel version (SST option) the tank is made of stainless steel AISI 304. It is also possible to configure the chiller without tank (NT option), for models provided with coaxial exchanger as standard, a plate evaporator will be used.

PUMP:

All models are provided as standard with pump with nominal pressure head 3 barg. The pumps are centrifugal type with motors in IE3 class (International Regulation IEC 60034-30), standard pump is suitable to work with ethylene or propylene glycol mixtures in concentration up to 30%. If pump is present the chiller is provided with:

- water pressure gauge on the outlet of the chiller
- internal by-pass between the hydraulic outlet and inlet connections (only for models 001÷005): its function is to preserve the integrity of the pump
- Shut-off valve on the suction side of the pump (VTP option, on request, available from model 003)
- Pump antifreeze wire heater (RAGP option, on request, available from model 008)
- Automatic bypass up to 50% of total flow rate (BPA option, on request, available for model 003÷185)

It is possible to configure the units with the options:

- double pump with nominal pressure head 3 barg (DP option, available from model 018)
- pump with nominal pressure head 5 barg (PH option, available from model 003)
- double pump with nominal pressure head 5 barg (DPH option, available from model 030 and for ENRF series)
- Without pump (NP option, available from model 008)

With double pump option (run and standby) the pumps are sized for 100% of total water flow and the switching from one pump to the other is automatic (every 24h

Die Modelle ENR.130÷480, CSE.130÷370, ENRF.022÷370 sind für einen geschlossenen Wasserkreislauf entworfen. Der Tank ist mit einem 3 bar/Ü Sicherheitsventil und manueller Entlüftung ausgestattet. Bei geschlossenen Wasserkreislauf-Konfigurationen kann der optionale XV zusätzlich eingesetzt werden, er umfasst Expansionskessel, ein automatisches Füllsystem und automatische Belüftung.

Bei allen Modellen ist der Tank mit einem Ablassventil ausgestattet, damit der Speicher geleert werden kann.

Der Tank kann mit einem Niedrig-Niveau-Schalter (Optional LLA, auf Nachfrage erhältlich), der das Gerät abstellt, wenn der Wasserstand unzureichend ist und einem Antifrost-Tauchsieder (Optional RAGT, auf nachfrage erhältlich für Modell 008) ausgerüstet werden. In der Version aus rostfreiem Stahl (Optional SST) ist der Tank aus rostfreiem AISI 304 Stahl hergestellt. Man kann den Kühler auch ohne Speichertank (Optional NT) konfigurieren. Bei Modellen mit einem standardmäßigen Koaxialverdampfer wird dann ein Plattenverdampfer verwendet.

PUMPE:

Alle Modelle sind standardmäßig mit einer Pumpe mit nominaler Druckhöhe von 3 bar/Ü ausgerüstet. Die Pumpen sind vom Zentrifugaltyp mit Motoren in der Klasse IE3 (Internationale Normen IEC 60034-30), die Standardpumpe ist geeignet für Ethylen- oder Propylen-Glykol-Mischungen in einer Konzentration von bis zu 30%. Wenn eine Pumpe vorhanden ist, ist der Kühler ausgerüstet mit:

- Wasserdruckmessgerät am Ablass des Kühlers.
- Interne Umleitung zwischen dem Ablass des Hydraulik-Kreislaufs und den Einlassanschlüssen (nur für die Modelle 001 ÷ 005), damit die Pumpe keinen Schaden nimmt.
- Absperrventile auf der Ansaugseite der Pumpe (Optional VTP, auf Nachfrage erhältlich ab Modell 003)
- Pumpe mit Anti-Frost Tauchsieder (Optional RAGP, auf Nachfrage ab Modell 008 erhältlich)
- Automatische Umleitung von bis zu 50% der Gesamtdurchflussrate (Optional BPA, verfügbar für die modelle 003 ÷ 185).

Es ist möglich, die Geräte mit folgenden Optionen zu konfigurieren:

- Doppelpumpe mit nominaler Druckhöhe von 3 bar/Ü (Optional DP, erhältlich ab Modell 018)
- Pumpe mit nominaler Druckhöhe von 5 bar/Ü (Optional PH, erhältlich ab Modell 003)
- Doppelpumpe mit nominaler Druckkopf von 5 bar/Ü (Optional DP, erhältlich ab Modell 030)
- Ohne Pumpe (Optional NP, erhältlich ab Modell 008)

Bei der Doppelpumpenoption (Run & Standby) sind die Pumpen für 100%



and in case of pump failure). With double pump option, shut-off valves on pump suction and check valves on pump discharge are included.

9 Integrated Free-Cooling (only ENRF series)

ENRF series is provided with integrated free-cooling, this system utilizes the cool outdoor air as a free cooling source through a water/air exchanger that allows a pre-cooling (or total cooling based on working conditions) of the process water before it is cooled by the evaporator; this solution allows to obtain greater energy efficiency and significant reductions of the running costs. Freecooling coil is installed in series with condenser coil: the air comes at first through the external coil dedicated to cooling the water and then through the main condensing coil dedicated to the refrigerant condensation. Considering the water circuit, the freecooling coil is installed before the evaporator: in this way the water flow, according with the air temperature, is pre-cooled or completely cooled before to enter in the evaporator water circuit. The particular installation of the coil allows easy cleaning of the finned pack.

Freecooling coil is provided with relief valve (for mod.130÷370), manual air vent and drain valve.

The freecooling operation is managed by the controller that reads the values of ambient temperature and freecooling inlet water temperature and operates on the freecooling valve and on the fans speed to allow the correct operation.

Freecooling valve allows the chiller to switch between freecooling and chiller mode, it is a 3-ways on/off valve for models 022÷185 and a couple of 2-ways on/off valves for models 200÷370.

With the version 2-ways valves it is also possible to balance the hydraulic circuit (in order to achieve the same pressure drop) during chiller operation and free-cooling mode.



Gesamtwasserdurchfluss ausgelegt und das Wechseln von einer Pumpe zur anderen erfolgt automatisch (alle 24 Stunden und bei Pumpenschaden). Bei der Doppelpumpenoption sind die Absperrventile am Ansaugstutzen und die Rückschlagventile am Auslassstutzen inbegriffen.

9 Integrierte Freikühlung (ausschließlich bei Serie ENRF)

Die Modelle der **ENRF** Serie sind mit einer integrierten Freikühlung ausgerüstet. Dieses System verwendet kalte Außenluft als freie Kühlquelle über einen Wasser/Luft-Austauscher, der eine Vorkühlung (oder Gesamtkühlung basierend auf den Arbeitsbedingungen) des Prozesswassers erlaubt, bevor es vom Verdampfer gekühlt wird. Es handelt sich um eine energieeffizientere Lösung, bei der die Betriebskosten erheblich gesenkt werden. Der Freikühlungsaustauscher (Wärmetauscher mit gerippten Aluminium-Lamellen aus Kupferrohrbündeln, gewellten Aluminiumrippen und Schultern aus verzinktem Stahlblech) wird in Reihe vor den Kondensator auf der Luftseite und in Reihe vor den Verdampfer auf der Wasserseite montiert. Er erlaubt eine gleichzeitige Verwendung des Freikühlungsmodus und der mechanischen Kühlung. Die besondere Installation der Spirale ermöglicht eine einfache Reinigung der Lamellen. Die Freikühlungsspirale ist mit einem Entlastungsventil (für Mod.130÷370), manueller Entlüftungsklappe und Ablassventil ausgestattet. Die Freikühlungsfunktion wird über den Controller gesteuert,

der die Werte der Umgebungstemperatur und die Freikühlungseinlasswassertemperatur misst und auf das Freikühlungsventil und die Lüftergeschwindigkeit wirkt, um einen korrekten Betrieb zu ermöglichen. Das Freikühlungsventil erlaubt dem Kühler zwischen Freikühlung und Kühlermodus zu wechseln. Bei den Modellen 022÷185 wird ein 3-Wege -Ventil und ein Paar 2-Wege-Ventile bei den Modellen 200÷370 verwendet. Mit dem 2-Wege-Ventil ist es zudem möglich, für einen Ausgleich des Druckabfalls (um den gleichen Druckabfall zu erhalten) während des Maschinen- und Freikühlbetriebs zu sorgen.

10 Electric Panel

The electrical cabinet is designed and wired in compliance with the Low Voltage Directive 2014/35/UE, standard EN 60204-1 and electromagnetic compatibility directive 2014/30/UE. It is composed of an enclosure accommodating all the components secured to a mounting plate, with a hinged door having a perimeter seal mounted to the cabinet structure. The door is also equipped with the main disconnect switch with safety door lock (door cannot be opened until the electrical cabinet power has been disconnected). The electrical cabinet utilizes components sourced from premium manufacturers and ensures a level of weather protection that is commensurate with outdoor installation of the chiller (protection rating IP54). The power section includes automatic thermal-magnetic cut-outs for the protection of power devices such as compressors (from model 008), fans (from model 030 and ENRF series) and centrifugal pumps (from model 030 and ENRF series), contactors, and (standard for model 200÷480) a phase monitor for protection of the unit from over/under voltage and incorrect phase sequence. The control section includes the transformer feeding the auxiliaries and the microprocessor circuit boards. A voltage-free general alarm contact is available from model 030, a remote ON/OFF is also available from model 008.



10 Elektrische Schalttafel

Der Schaltschrank ist in Übereinstimmung mit der Niederspannungsrichtlinie 2014/35/EU, EN 60204-1 und der Richtlinie für Elektromagnetische Verträglichkeit 2014/30/EU entworfen und verkabelt. Es besteht aus einem Gehäuse, das sämtliche Komponenten auf einer Montageplatte beinhaltet, mit einer Drehtür mit einem an der Schrankstruktur montierten Dichting. Die Tür ist zudem mit einem Hauptschalter mit Sicherheitsschloss ausgestattet (die Tür lässt sich nicht öffnen, bis die Spannungsversorgung des Schaltschranks abgeschaltet ist). Im Schaltschrank befinden sich Komponenten von Premium-Herstellern und sorgen für Wetterschutz und die Außenaufstellung der Kältemaschine (Schutzart IP54). Der Stromabschnitt hat automatische thermomagnetische

Ausschalter zum Schutz der Stromgeräte wie die Kompressoren (ab Modell 008), Ventilatoren (ab Modell 030 und ENRF Serie) und Zentrifugalpumpen (ab Modell 030 und ENRF Serie), Kontaktschalter und (standardmäßig für Modelle 200÷480) einen Phasenmonitor zum Schutz der Einheit vor Über/Unterspannung und falschen Phasenfolgen. Der Steuerabschnitt beinhaltet den Transformator zur Versorgung der Hilfsvorrichtungen sowie der Mikroprozessor-Leiterplatten. Ein spannungsfreier allgemeiner Alarm-Kontakt ist erhältlich ab Mod. 030, ein Remote EIN/AUS-Schalter ist erhältlich ab Modell 008.

11 Control and Safety Devices

High pressure transducers: The pressure transducers measure the compressor discharge pressure, the resulting signal is utilized by the electronic controller for the following functions: high pressure measurement and alarms, condensing pressure regulation through the electronic fans speed control. Standard for ENR series (models 200÷480), ENRF series (complete range), CSE series (models 130÷370) and option for models 030÷185.

Temperature probes: installed on the hydraulic circuit, they measure the temperature values of:

- evaporator outlet water/tank: this probe has antifreeze function for all the series ENR, ENRF, CSE (for models 030÷480 and for ENRF series it allows also the pump to start if the chiller is in off mode). For models ENR 001÷022 it has also the temperature control function.
- evaporator inlet water: this probe has temperature control function, standard for models 030÷480 and for

11 Steuer- und Sicherheitsvorrichtungen

Hochdruckgeber: Die Druckgeber messen den Förderdruck des Kompressors. Das dadurch entstehende Signal wird von der elektronischen Steuerung für folgende Funktionen genutzt: Hochdruckmessung und Alarmmeldungen, Verflüssigungsdruckregelung durch die elektronische Drehzahlregelung der Ventilatoren. Standardmäßig für die ENR Serie (Modelle 200÷480), ENRF Serie (komplettes Sortiment), CSE Serie (Modelle 130÷370) und optional für die Modelle 030÷185.

Temperaturfühler: installiert in den Hydraulikkreislauf messen sie die Temperaturwerte von:

- Verdampfer Wasserauslass/Speichertank: Der Temperaturfühler hat eine Gefrierschutzfunktion für alle Serien ENR, ENRF, CSE (für die Modelle 030÷480 und für die ENRF Serie ermöglicht er außerdem der Pumpe zu starten, wenn der Kühler im OFF-Modus ist. Bei den Modellen ENR 001÷022 hat er auch eine Temperaturkontrollfunktion.

ENRF series.

- freecooling inlet water: this probe is used to manage the freecooling operation (only ENRF series)
- ambient: this probe is used to manage the freecooling operation (only ENRF series)

High and low pressure switches: they are installed on the refrigerant circuit high/low pressure side, respectively; they stop the compressor if anomalous working pressures are detected (high pressure switch is standard from model 004, low pressure switch is standard from model 030).

Fans pressure switch: it is used for ON/OFF control of the fans (standard from model 008).

Flow switch: it is used to shut-down the unit if an insufficient water flow is detected (standard for models 030÷480 and for ENRF series).

Low level switch (option): it is installed in the tank, it is used to shut-down the unit if an insufficient water level is detected.

Axial fans electronic control device: this device consists of an electronic controller board (phase-cut for ENR/ENRF, inverter for CSE) which changes the rpm of the axial fans on the basis of the condensation pressure detected by the high pressure transducer. This logic allows correct operation in cooling also with outside temperatures below -3°C. Fans speed regulation is standard for ENRF series, ENR.200÷480, CSE.130÷370

Anti-freezing heating elements (RAGT, RAGE, RAGP option): these are heating wire or immersion elements for evaporator, tank and pumps; their working is controlled electronically by means of the evaporator outlet probe (option available from model 008).

Remote ON/OFF (OFR option): this kit makes it possible the remote control of the unit (ON/OFF) up to a maximum distance of 150 m and consists of a plastic box with ON/OFF switch

Remote Terminal (OFRC option): this kit makes it possible the remote control of the unit (all the functions of the unit's onboard electronic controller) up to a maximum distance of 250 m (shielded cable required - not supplied). This terminal performs also the remote ON/OFF function. option available from model 008.

RS485 (RS485 option): RS485 serial option is used to connect the controller to a supervisor network via a standard RS485 serial line.

12 Electronic Control

ENR and **CSE** are controlled and managed by the electronic controller Dixell XR30CX for mod.001÷022, Carel Microchiller 2 SE for mod. 030÷480. Thanks to the control menu it is possible to visualize the working conditions,

- *Verdampfer Einlasswasser:* Dieser Temperaturfühler hat eine Temperaturkontrollfunktion, standardmäßig für die Modelle 030÷480 und die ENRF Serie.

- *Freikühlung Wassereinlass:* Dieser Temperaturfühler wird für die Steuerung der Freikühlung verwendet (nur ENRF Serie).

- *Raum:* Dieser Temperaturfühler wird für die Steuerung der Freikühlung verwendet (nur ENRF Serie).

Hoch- und Niederdruckschalter: Diese Schalter werden auf der Hoch/Niederdruckseite des Kühlmittelkreislaufes eingebaut; sie halten den Kompressor an, wenn ein anomaler Arbeitsdruck gemessen wird (der Hochdruckschalter ist standardmäßig ab Modell 004 eingebaut, der Niederdruckschalter ab Modell 012).

Druckschalter der Ventilatoren: für EIN/AUS Schaltung der Lüfter (standardmäßig ab Modell 008).

Durchflussschalter: wird verwendet, um die Anlage abzuschalten, wenn ein unzureichender Wasserdurchfluss gemessen wird (standardmäßig für die Modelle 030÷480 und die ENRF-Serie).

Low-Level-Schalter (optional): ist im Tank installiert, um das Gerät abzuschalten, falls ein unzureichender Wasserpegel festgestellt wird.

Elektronisches Steuergerät für Axiallüfter: Das Gerät besteht aus einer elektronischen Steuerplatine (Phasenanschnitt), durch welche die Drehzahl der Axialventilatoren auf Grundlage des durch den Hochdruckwandler festgestellten Kondensationsdrucks geändert wird. Diese Logik ermöglicht einen korrekten Betrieb auch bei Außentemperaturen unter -3°C. Der Lüftergeschwindigkeitsregler ist standardmäßig in die ENRF Serie, ENR.200÷480, CSE 130÷370 eingebaut.

Heizelemente für den Gefrierschutz (optional RAGT, RAGE, RAGP): Dabei handelt es sich um Heizdrähte oder Tauchsieder für Verdampfer, Wassertanks oder Pumpen; sie werden elektronisch über den Temperaturfühler am Verdampferauslass gesteuert (optional erhältlich ab Modell 008).

Remote AN/AUS (optional OFR): Dieses Kit ermöglicht es, die AN-/AUS-Schaltung des Gerätes bis zu einer maximalen Entfernung von 150 m fernzusteuern. Sie besteht aus einer Kunststoffbox mit Ein-/Ausschalter.

Remote-Endgerät (optional ORFRC): Dieses Kit ermöglicht es, sämtliche Funktionen des elektronischen Steuerboards des Gerätes bis zu einer maximalen Entfernung von 250 m fernzusteuern (geschütztes Kabel erforderlich - nicht im Lieferumfang enthalten). Dieses Endgerät hat außerdem die Remote-AN/AUS-Funktion. Optional ab Modell 008 erhältlich

RS485 (optional RS485): Die RS485 Serie Option wird eingesetzt, um den Controller an ein Supervisor-Netzwerk über den RS485-Standard anzuschließen.

12 Elektronische Steuerung

ENR und **CSE** werden durch den elektronischen Controller Dixell XR30CX für Mod. 001÷022, Carel Microchiller 2 SE für Mod. 030÷100 und dixell iCHILL für Mod. 130÷480 gesteuert und verwaltet. Dank des Steuermenüs ist es möglich, Betriebsbe-

the parameters and the possible alarms. The control is installed on the electrical panel and is protected by a flip-up polycarbonate cover.

XR30CX functions (for mod.

001÷022):

- Thermostatic control depending on the process fluid temperature in the tank (proportional)
- Process fluid temperature in the tank display
- Modbus serial interface (option)
- Management of alarm messages: general alarm



nat geschützt.

XR30CX Funktionen (für Mod. 001÷022):

- Thermostatische Regelung abhängig von der Flüssigkeitstemperatur im Behälter (proportional)
- Prozessfluidtemperatur auf der Tankanzeige
- Modbus serielle Schnittstelle (optional)
- Management von Alarmmeldungen: Allgemeiner Alarm

Microchiller 2 SE functions (for

mod.030÷480):

- Thermostatic control depending on the process fluid inlet temperature (proportional)
- Process fluid inlet temperature display
- Process fluid outlet temperature display for management of the antifreeze heaters (when present) and management of start-up of the pump under conditions of low temperature
- Management of the automatic rotation of the starting sequence of compressors for equalization of the operating times for each compressor (twin configuration)
- Measurement and display of the condensation pressure (standard for ENR 200÷480, option for ENR 030÷185)
- Management of condenser control
- Management of anti-freezing heaters and pump switch on with low ambient temperature
- Display of the alarms
- Modbus serial interface (option)
- Count of operating hours of the unit and of the individual compressors
- Voltage-free contact available for remote general alarm signal
- Management of alarm messages: high condensing pressure alarm, low evaporation pressure alarm, freeze alarm on water at evaporator outlet, compressor fault alarm, pump thermal protection alarm, flow switch alarm



Mikrokühler 2 SE-Funktionen (für Mod. 030 ÷ 480):

- Thermostatische Kontrolle abhängig von der Inlasteremperatur der Flüssigkeit (proportional)
- Temperaturanzeige des Prozessfluideinlasses
- Temperaturanzeige des Prozessfluidauslasses zur Verwaltung der Frostschutzheizungen (falls vorhanden) und zur Kontrolle der Pumpenstarts unter niedrigen Temperaturbedingungen
- Kontrolle der automatischen Rotation der Ausgangssequenz von Verdichtern zum Ausgleich der Betriebszeiten für jeden Verdichter (Twin)
- Messung und Anzeige des Kondensationsdrucks (Standardmäßig für ENR 200÷480 optional für ENR 030÷185)
- Management der Kondensatorsteuerung
- Management der Frostschutzheizungen und Pumpenschalter bei niedriger Umgebungstemperatur
- Anzeige der Alarmmeldungen
- Modbus serielle Schnittstelle (optional)
- Zähler der Betriebsstunden des Gerätes sowie der einzelnen Kompressoren
- Spannungsfreier Kontakt erhältlich für das Remote-Alarmsignal
- Management von Alarmmeldungen: Alarm aufgrund hohen Verflüssigungsdrucks, Alarm aufgrund niedrigen Verdampfungsdrucks, Alarm aufgrund Einfrierung von Wasser am Verdampferaustritt, Fehleralarm des Kompressors, Wärmeschutz-Alarm der Pumpe, Alarm des Durchflussschalters

ENRF is equipped with Carel pCO 5 plus microprocessor control. The electronic chiller control is performed by a control system with Hitema software. Programming and input the nominal values (operating data) are done directly on the display that also shows any malfunctions giving a description of them. There is also a visual (and acoustic) alarm. The parameters set are maintained also in the event of a power cut.

ENRF ist mit Carel pCO 5 sowie mit einer Steuerung des Mikroprozessors ausgestattet. Die elektronische Kühlungsregelung wird durch ein Steuersystem mit der Hitema Software durchgeführt. Programmierung und Eingabe der Sollwerte (Betriebsdaten) werden direkt auf dem Display, das auch eventuelle Fehlfunktionen mit einer Beschreibung anzeigt, durchgeführt. Es gibt auch einen visuellen (und akustischen) Alarm. Die eingestellten Parameter werden für den Fall eines Stromausfalls gespeichert.

**pCO5 functions
 (for model ENRF.022÷370):**

- Thermostatic control depending on the process fluid inlet temperature (proportional)
- Process fluid inlet temperature display (PGD0/semi-graphic/6 buttons/4 rows - 20 columns)
- Process fluid outlet temperature display for management of the antifreeze heaters (when present) and management of start-up of the pump under conditions of low temperature
- Management of the automatic rotation of the starting sequence of compressors for equalization of the operating times for each compressor (twin configuration)
- Measurement and display of the condensation pressure
- Measurement and display of the evaporation pressure
- Management of condenser control
- Management of anti-freezing heaters and pump switch on with low ambient temperature
- Management of free-cooling, fans and free-cooling valve
- Display of the alarms
- Modbus serial interface (option)
- Count of operating hours of the unit and of the individual compressors and pump
- Voltage-free contact available for remote general alarm signal
- Management of alarm messages: high condensing pressure alarm, low evaporation pressure alarm, freeze alarm on water at evaporator outlet, compressor fault alarm, pump thermal protection alarm, flow switch alarm
- Management of alarm log: the alarm log is used to save the operating status of the chiller when the alarms are generated. Each record saved to the memory represents an event that can be displayed.



**pCO5 Funktionen
 (für die Modelle ENRF.022÷370):**

- Thermostatische Kontrolle abhängig von der Einlasstemperatur der Flüssigkeit (proportional)
- Anzeige für die Prozessflüssigkeitseinlasstemperatur (PGD0/halbglyphisch/6Tsten/4Zeilen-20 Spalten)
- Temperaturanzeige des Prozessfluidauslasses zur Verwaltung der Frostschutzheizungen (falls vorhanden) und zur Kontrolle der Pumpenstarts unter niedrigen Temperaturbedingungen
- Kontrolle der automatischen Rotation der Ausgangssequenz von Verdichtern zum Ausgleich der Betriebszeiten für jeden Verdichter (Twin)
- Messung und Anzeige des Kondensationsdrucks
- Messung und Anzeige des Verdampfungsdrucks
- Kontrolle des Kondensators
- Kontrolle der Frostschutz Tauchsieder und Pumpenschalter bei niedriger Umgebungstemperatur;
- Management der Freikühlung, Ventilatoren und Freikühlungsventil
- Anzeige der Alarmmeldungen
- Modbus serielle Schnittstelle (optional)
- Zähler der Betriebsstunden des Gerätes sowie der einzelnen Kompressoren und der Pumpe.
- Spannungsfreier Kontakt erhältlich für das Remote-Alarm-signal
- Management von Alarmmeldungen:
 Alarm aufgrund hohen Verflüssigungsdrucks Alarm aufgrund niedrigen Verdampfungsdrucks Alarm aufgrund Einfrierung von Wasser am Verdampferaustritt Fehleralarm des Kompressors Wärmeschutz Alarm der Pumpe Alarm des Durchflussschalters
- Management der Alarmchronologie: Die Alarmchronologie wird verwendet, um den Betriebsstatus des Kühlers, wenn der Alarm ausgelöst wird, zu speichern. Jede im Speicher gespeicherte Aufzeichnung stellt ein Ereignis dar, das angezeigt werden kann.

13 Testing

All units are factory tested and supplied complete with oil and refrigerant charge.
 The main checks performed are as follows:
 the correct installation of all the components and the absence of refrigerant leaks
 electrical safety tests as prescribed by EN60204-1

13 Überprüfung

Alle Geräte sind im Werk getestet und werden komplett mit Öl- und Kühlmittelfüllung geliefert.
 Die Haupttests, die an den Geräten durchgeführt werden, sind:
 Die korrekte Installation aller Bauteile und Dichtheitsprüfung, dass kein Kühlmittel austritt.
 Elektrische Sicherheitstest sind von der EN60204-1 vorge-

correct operation of the microprocessor and correct values of all the operating parameters;
 correct operation of temperature probes and pressure transducers

14 Main options

ENR, ENRF, CSE can be customized with the options below described to meet a very broad range of plant requirements. **WARNING:** when you are configuring the unit it should be remembered that not all the combinations are possible. Please contact the sales dept. For any doubt. Please take a look at table "standard/option/not Available" of Chapter 17 "Table standard/optional/not Available" to know what are the standard, optional and not available features for each model.

Description for the available options:

schrieben

Korrektur Betrieb des Mikroprozessors und korrekte Werte aller Betriebsparameter;

Korrektur Betrieb der Temperaturfühler und Druckwandler

14 Hauptauswahl

ENR, ENRF, CSE kann mit den unten beschriebenen Optionen kundenspezifisch ausgerüstet werden, um sehr vielen verschiedenen Anforderungen in Werksanlagen nachkommen zu können. **WARNUNG:** Beim Konfigurieren des Geräts muss bedacht werden, dass nicht alle Kombinationen möglich sind. Bitte wenden Sie sich bei Zweifeln an die Verkaufsabteilung.

Bitte schauen Sie für jedes Modell die standardmäßigen, optionalen und nicht verfügbaren Eigenschaften in der Tabelle "Standard/Optional/Nicht verfügbar" im Kapitel 17 "Datenblatt mit optional (Standard/Optional/Nicht verfügbar)" nach.

Beschreibung der zur Verfügung stehenden Optionen:

Description	abbr.	Beschreibung
MECHANICAL CONFIGURATION		MECHANISCHE KONFIGURATION
Spring type antivibration dampers, to reduce the vibrations transmitted to the ground	ATS	Federnde Vibrationsdämpfer, um die auf den Boden übertragenden Vibrationen zu verringern.
Rubber type antivibration dampers, to reduce the vibrations transmitted to the ground	ATV	Vibrationsdämpfer aus Gummi, um die auf den Boden übertragenden Vibrationen zu verringern.
Customized painting for frame and panels. Please specify the RAL colour in the order.	CRAL	Kundenspezifischer Anstrich des Rahmens und der Paneele. Bitte geben Sie die RAL-Nummer bei der Bestellung an.
Aluminum filter to protect finned coil heat exchangers from dust and soft mechanical impact. Mounted as an alternative to the grid for coil protection	CF	Aluminiumfilter zum Schutz der gerippten Aluminium-Lamellen vor Staub und weichem mechanischen Einschlag. Montiert als Alternative zu dem Grill für den Verflüssigerschutz.
Epoxy coated finned coil heat exchanger and stainless steel fasteners. Recommended for applications in medium level pollution atmospheres.	CV	epoxidharz beschichteter Kondensator. Empfohlen für Anwendungen in leicht aggressive Umgebung, z.B. Meeresklima
ElectroFin (Electrophoretic deposition) coated finned coil heat exchanger and stainless steel fasteners. Recommended for marine exposure conditions, with an high level of pollution or other aggressive atmospheres.	CG	ElectroFin (elektrophoretische Ablagerung) beschichteter Lamellen-Wärmeaustauscher/ Kondensator. Empfohlen für aggressive Umgebungen, z.B. direktes Meeresklima oder ander aggressive Umgebungen
Air heat exchanger with copper fins and copper tubes and stainless steel fasteners. Recommended for applications in corrosive atmospheres.	CC	Kondensator mit Kupferlamellen und Kupferrohren. Empfohlen für aggressive Umgebungen
Internal fan guard to protect serviceman during maintenance operation	IFG	Interne Lüfterhaube zu Soldaten während der Wartungsbetrieb zu schützen
Galvanized and painted (RAL7035) main frame and panels	GALV	Verzinkte und lackierte (Ral7035) Hauptrahmen und Paneele.

Description	abbr.	Beschreibung
Low noise version, it includes compressor jackets on compressors and fans speed regulation if not already included.	LNJ	Geräuschreduzierte Ausführung. Beinhaltet Verdichter-Schallschutzhaube und drehzahlgeregelten Ventilator, wenn nicht schon im Lieferumfang enthalten
Panel to separate refrigerating and electrical section from hydraulic and condenser section. It allows easy chiller calibration and maintenance.	PAN	Trennplatte, um den Kühlungs- und elektrischen Abschnitt von dem Hydraulik- und Kondensatorabschnitt zu trennen. Die Trennplatte erlaubt eine einfache Kalibrierung und Wartung des Kühlers.
Wheels to make the chiller movable (2 fixed and 2 swivel, with brakes)	WHE	Räder, damit der Kühler bewegt werden kann (2 feststehende und 2 Schwenkräder, mit Bremsen)
HYDRAULIC CIRCUIT CONFIGURATION		KONFIGURATION DES HYDRAULIKKREISLAUFES
Closed water circuit, it includes 3 barg safety valve and manual air vent.	CWC	geschlossener Wasserkreislauf, beinhaltet ein 3 bar Sicherheitsventil und ein manuelles Entlüftungsventil
Water storage tank in carbon steel. In case of coaxial evaporator the evaporator is mounted inside the tank.	CST	Wasserspeichertank aus Kohlenstoffstahl. Bei koaxialem Verdampfer ist der Verdampfer in den Tank eingebaut.
Water storage tank in stainless steel AISI304. In case of coaxial evaporator the evaporator is mounted inside the tank.	SST	Wasserspeichertank aus rostfreiem Stahl AISI304. Bei koaxialem Verdampfer ist der Verdampfer in den Tank eingebaut.
Without tank	NT	Ohne Speicher
Internal mounting expansion vessel kit available with closed water circuit configuration, it includes expansion vessel, automatic filling system and automatic air vent	XV	Intern zu montierender Expansionskessel ist im Kit erhältlich für eine Konfiguration mit geschlossenem Wasserkreislauf; der Bausatz umfasst einen Expansionskessel, ein automatisches Einfüllsystem und eine automatische Lüftungsklappe.
Low level switch installed in the tank, it is used to shut-down the unit if an insufficient water level is detected.	LLA	Low-Level-Schalter (optional) ist im Tank installiert, um das Gerät abzuschalten, falls ein unzureichender Wasserpegel festgestellt wird.
Brazed plate evaporator (plate material AISI 316, brazing material copper). As an alternative to coaxial or shell and tube evaporator	B-ES	Hartgelöteter Plattenverdampfer (Plattenmaterial AISI 316, Lötmaterial Kupfer). Als Alternative zum Koaxial- oder Rohrbündelverdampfer
Coaxial evaporator, installed inside the water storage tank (outer tube in carbon steel, inner tubes in copper). In case of stainless steel tank the outer tube is in stainless steel AISI304, and inner tubes are in copper	CX	Koaxial-Verdampfer, eingebaut in den Wasserspeichertank (Außenrohr aus Kohlenstoffstahl, Innenrohre aus Kupfer). Bei einem Tank aus rostfreiem Stahl ist das Außenrohr aus rostfreiem Stahl AISI304 und die Innenrohre aus Kupfer.
Shell and tube evaporator (shell in carbon steel, tubes in copper)	ST	Rohrbündelverdampfer (Außen Kohlenstoffstahl, Rohre aus Kupfer)
Pump with nominal pressure head 3 barg	WP	Pumpe mit nominaler Druckhöhe von 3 bar/Ü

Description	abbr.	Beschreibung
Double pump (run and standby, with automatic changeover every 24h or on fault) with nominal pressure head 3 barg. pumps sized for 100% of total water flow with automatic switching from one pump to the other. It includes shut-off valves on pump suction and check valves on pump discharge.	DP	Doppelpumpe (Run&Standby, mit automatischem Wechsel nach 24 Stunden (oder bei Pumpenschaden) mit einer nominalen Druckhöhe von 3 bar/Ü. Die Pumpen sind für 100% des Gesamtwasserdurchflusses mit der automatischen Schaltung von einer Pumpe zur anderen ausgelegt. Bei der Doppelpumpe sind die Absperrventile am Ansaugstutzen und die Rückschlagventile am Auslassstutzen inbegriffen.
Pump with nominal pressure head 5 barg	PH	Pumpe mit nominaler Druckhöhe von 5 bar/Ü
Double pump (run and standby, with automatic changeover every 24h or on fault) with nominal pressure head 5 barg. pumps sized for 100% of total water flow with automatic switching from one pump to the other. It includes shut-off valves on pump suction and check valves on pump discharge.	DPH	Doppelpumpe (Run&Standby, mit automatischem Wechsel nach 24 Stunden oder bei Pumpenschaden) mit einer nominalen Druckhöhe von 5 bar/Ü. Die Pumpen sind für 100% des Gesamtwasserdurchflusses mit der automatischen Schaltung von einer Pumpe zur anderen ausgelegt. Bei der Doppelpumpe sind die Absperrventile am Ansaugstutzen und die Rückschlagventile am Auslassstutzen inbegriffen.
Without pump	NP	ohne Pumpe
Antifreeze wire heater for evaporator (for shell&tube and plate evaporators)	RAGE	Frostschutz-Heizdraht für Verdampfer (für Rohrbündel- und Plattenverdampfer)
Antifreeze immersion heater for tank	RAGT	Frostschutz-Tauchsieder für Speicher
Antifreeze wire heater for one pump (to combine with WP or PH)	RAGP	Frostschutz-Heizdraht für eine Pumpe (zu verbinden mit WP oder PH)
Antifreeze wire heater for double pump (to combine with DP or DPH). The price for the optional is 2 times the price of RAGP	RAGDP	Frostschutz-Heizdraht für eine Doppelpumpe (zu verbinden mit DP oder DPH). Der Preis für die optionale Ausrüstung ist doppelt so hoch wie der Preis von RAGP.
Automatic bypass to preserve the integrity of the pump. It allows to bypass up to 50% of the total flow rate. Externally mounted for models from 003 to 100 and internally mounted for models from 130 to 185	BPA	automatisches Bypass-Ventil zum Schutz der Pumpe. Ermöglicht einen Bypass von bis zu 50% des Volumenstroms. Extern montiert bei Modellen von 003 bis 100, integriert montiert bei den Modellen 130 bis 185
Shut-off valve on pump suction. To allow easy pump maintenance. The optional is available with sigle pump WP or PH. Optional not included with NT.	VTP	Ventil an der Pumpeneinheit. Für vereinfachte Wartung und Service. Diese Option ist für Einzelpumpen WP oder WH erhältlich

Description	abbr.	Beschreibung
Single pump allowed to work with ethylene or propylene glycol percentage in the range from 30% to 50% in weight. It implies verification for the pump to work in this range and special seals and special pump motor if required. Optional required with single pump and glycol percentage higher than 30%.	GL50	Einzel-Pumpen für den Einsatz mit Ethylen- oder Propylenglykolanteil von 30% bis 50% Gewichtsanteil. Hierbei muss der Einsatzbereich der Pumpe verifiziert werden, sowie, wenn notwendig, die Gleitringdichtung und der Motor angepasst werden. Diese Option ist bei einem Glykolanteil von über 30% erforderlich
Double pumps allowed to work with ethylene or propylene glycol percentage in the range from 30% to 50% in weight. It implies verification for the pump to work in this range and special seals and special pump motor if required. Optional required with double pump and glycol percentage higher than 30%.	GL50D	Doppel-Pumpen für den Einsatz mit Ethylen- oder Propylenglykolanteil von 30% bis 50% Gewichtsanteil. Hierbei muss der Einsatzbereich der Pumpe verifiziert werden, sowie, wenn notwendig, die Gleitringdichtung und der Motor angepasst werden. Diese Option ist bei einem Glykolanteil von über 30% erforderlich. Der Preis dieser Option ist zwei mal der Preis von GL50
REFRIGERANT CIRCUIT CONFIGURATION		KONFIGURATION DES KÜHLMITTELKREISLAUFES
Shut-off valves on suction and discharge lines, to simplify maintenance activities	CSV	Absperrventil auf den Ansaug- und Ablassleitungen, um die Wartungsarbeiten zu erleichtern.
Hot gas bypass valve (with shut-off valve and solenoid valve) to allow precise control of the leaving water temperature (+/-1K).	PMC	Heißgas-Bypass-Ventil (mit Absperrventil und Magnetventil) für eine präzise Kontrolle der Temperatur des abgehenden Wassers (+/-1K).
Low ambient temperature kit to allow the chiller to work down to -25°C (-10°C for CFT models). It includes fans speed regulation, crankcase heaters for compressors, electric board heater and adjustable low pressure switch (if present).	LT	Winterregelung, damit der Kühler bis zu -25 °C (-10 °C bei CFT-Modellen) arbeiten kann. Sie umfasst Drehzahlregelung der Ventilatoren, Kurbelwannenheizung, Schaltschrankheizung und einstellbare Niederdruckschalter (falls vorhanden).
Leaving water temperature down to -10°C: it includes 19mm insulation, optionals RC and RV, optional FL and WC1 (if not included in standard configuration), pumps (if present) verified to work with this working condition and adjustable low pressure switch (if present).	LW	Vorlauftemperatur bis zu -10 °C: Beinhaltet 19mm Tank-Isolierung, Optionen RC und RV, optional FL und WC1 (falls nicht in der Standardkonfiguration enthalten), Pumpen (falls vorhanden) geprüft ggf. angepasst an den Betriebszustand, sowie einstellbare Niederdruckschalter (falls vorhanden).
High pressure gauge, allows immediate reading of the pressure of the high pressure line	HPG	Hochdruckmessgerät, erlaubt das Ablesen des aktuellen Drucks auf der Hochdruckleitung
Low pressure gauge, allows immediate reading of the pressure of the low pressure line	LPG	Niederdruckmessgerät, erlaubt das Ablesen des aktuellen Drucks auf der Niederdruckleitung
High pressure switch with automatic reset, to allow chiller protection from high pressure events by switching off the chiller	HP	Hochdruckschalter mit automatischer Zurückstellung, um den Kühler vor Schäden durch Hochdruck beim Ausschalten zu schützen.

Description	abbr.	Beschreibung
Refrigerant components designed for a leaving water temperature between 15°C and 20°C	HW	Der Kältekreis ist für Vorlauftemperaturen von 15 °C bis 20 °C ausgelegt.
Low pressure switch with automatic reset, to allow chiller protection from low pressure events by switching off the chiller	LP	Niederdruckschalter mit automatischer Zurückstellung, um den Kühler vor Schäden durch Niederdruck beim Ausschalten zu schützen.
Partial desuperheater in series with the condenser, capable of 25% of the total heat rejection with water 40°C/45°C at standard working conditions.	PDS	Teildampfkühler in Reihenschaltung mit Kondensator, kann 25% des gesamten Hitzeabstoßes bei einer Wassertemperatur von 40/45°C unter Standardarbeitsbedingungen übernehmen.
Double interlocked relief valves (high and low pressure if present) with changeover device to allow easy replacement of the valves.	DRV	Verriegelte Doppelentlastungsventile (Hoch- und Niederdruck) mit Umschaltvorrichtung, damit die Ventile leicht ersetzt werden können.
Electronic expansion valve	ETS	Elektronisches Expansionsventil
Double refrigerant circuit to allow higher reliability for the chiller. Optional available only for chillers provided as standard with two compressors in one refrigerant circuit.	DC	Doppelter Kühlmittelkreislauf, um eine höhere Zuverlässigkeit des Kühlers zu erlauben. Dieses Optional ist nur für Kühler erhältlich, die standardmäßig mit zwei Kompressoren in einem Kühlmittelkreislauf ausgerüstet sind.
Crankcase heater for each compressor	RC	Kurbelgehäuseheizung für jeden Kompressor
ELECTRIC CIRCUIT CONFIGURATION		KONFIGURATION DES STROMKREISLAUFES
Auxiliary contacts providing a voltage-free signal, to allow remote signalling of compressor's activation	OFC	Hilfskontakte, die ein spannungsfreies Signal geben, um eine ferngesteuerte Signalisierung der Kompressoraktivität zu erlauben.
Remote ON/OFF control: this kit makes it possible the remote control of the unit (ON/OFF) up to a maximum distance of 150 m and consists of a plastic box with ON/OFF switch	OFR	EIN/AUS-Fernsteuerung: Dieses Kit ermöglicht es, die AN-/AUS-Schaltung des Gerätes bis zu einer maximalen Entfernung von 150 m fernzusteuern. Sie besteht aus einer Kunststoffbox mit Ein-/Ausschalter.
Remote Terminal: this kit makes it possible the remote control of the unit (all the functions of the unit's onboard electronic controller) up to a maximum distance of 250 m (shielded cable required - not supplied). This terminal performs also the remote ON/OFF function.	OFRC	Remote-Endgerät: Dieses Kit ermöglicht es, sämtliche Funktionen des elektronischen Steuerboards des Gerätes bis zu einer maximalen Entfernung von 250 m fernzusteuern (geschütztes Kabel erforderlich - nicht im Lieferumfang enthalten). Dieses Endgerät hat außerdem die Remote-AN/AUS-Funktion.
Serial card for modbus RS485, it is used to connect the controller to a supervisor network via a standard RS485 serial line.	RS485	Serienkarte für Modbus RS485, wird eingesetzt, um den Controller an ein Supervisor-Netzwerk über den RS485 -Standard anzuschließen.

Description	abbr.	Beschreibung
Electronic fan speed control (cut-phase) according to the condensation pressure. Fans speed can be reduced down to 30% of the maximum. The use of this device is mandatory in case the unit operates with low leaving water temperature and in case the chiller is required to operate with low ambient temperature. Maximum operating ambient temperature for this device 45°C. Please verify the compatibility in the use of the RV: the voltage distortion, for the electrical supply of the chiller, must be lower than the limits reported in the EN 61800-3.	RV	Elektronische Lüfterdrehzahlregelung (Cut-Phase) in Abhängigkeit vom Kondensationsdruck. Die Lüftergeschwindigkeit kann bis zu 30% der maximalen Drehzahl reduziert werden. Die Verwendung dieses Gerätes ist zwingend erforderlich, wenn das Gerät mit einer niedrigen Wassertemperatur arbeitet und falls der Kühler mit einer niedrigen Umgebungstemperatur arbeiten muss. Maximale Betriebsumgebungstemperatur für dieses Gerät 45 °C. Bitte überprüfen Sie die Kompatibilität bei der Verwendung des RV: Die Spannungsverzerrung der elektrischen Versorgung der Kältemaschine muss niedriger sein als die in der EN 61800-3 angegebenen Grenzwerte.
Electronic commuted (EC) fans with permanent-magnet brushless DC motor. Fans speed control (inverter) according to the condensation pressure. Fans speed can be reduced down to 0% of the maximum. Optional available as an alternative to RV. It is also suggested to use EC fans in case of aggressive atmosphere (coastal atmosphere or chemical industry) and in case of ambient temperature over 45°C.	EC	Elektronisch geregelte (EC) Ventilatoren mit permanentmagnetischem bürstenlosen Gleichstrommotor. Lüfter Drehzahlregelung (Wechselrichter) in Abhängigkeit vom Kondensationsdruck. Die Lüftergeschwindigkeit kann bis zu 0% der maximalen Drehzahl reduziert werden. Optional als Alternative zum RV erhältlich. Es wird auch vorgeschlagen, EC-Lüfter im Falle einer aggressiven Atmosphäre (Küstenatmosphäre oder chemische Industrie) und bei Umgebungstemperatur über 45 °C zu verwenden.
Axial EC fans with high head pressure (about 120÷150Pa available) to allow air ducting	ECH	Axial EC-Ventilatoren mit hoher Kopfdruck (etwa 120÷150 Pa vorhanden) zur Luftführung ermöglichen
Phase monitor for protection of the unit from over/under voltage and incorrect phase sequence	RVG	Phasenmonitor zum Schutz der Anlage vor Über/Unterspannung und falscher Phasenfolge.
Soft start: electronic device adopted to manage the inrush current. It allows to break down the inrush current as soon as the electrical motor is switch on, to reduce motor's mechanical wear and a favourable sizing for the electrical system.	SF	Soft Start: Elektronische Vorrichtung, um den Einschaltstrom zu kontrollieren. Damit kann der Einschaltstrom aufgeteilt werden, sobald der Elektromotor eingeschaltet ist, um die mechanische Abnutzung des Motors zu reduzieren, und für eine günstige Bemessung für das elektrische System.
Supervision of the chiller with Plantvisor. Available only with Carel controllers	PLV	Überwachung des Kühlers mit Plantvisor. Nur mit Carel Controller erhältlich
Supervision of the chiller with Plantwatch pro. Available only with Carel controllers	PLW	Überwachung des Kühlers mit Plantwatch pro. Nur mit Carel Controller erhältlich
Remote inverter for fans speed control according to the condensing pressure (only for CSE serie). Suitable for indoor use only (for outdoor use please contact our sales dep.)	IR	Ferngesteuerter Umrichter für die Steuerung der Lüftergeschwindigkeit nach dem Kondensationsdruck (nur für die CSE-Serie). Nur geeignet für Innenräume (für die Installation im Außenraum wenden Sie sich bitte an unsere Verkaufsabteilung)

Description	abbr.	Beschreibung
Individual remote inverter for compressors. Compressors allowed to work in the range from 40Hz to 60Hz. It includes also the optional DC in case of chillers provided as standard with 2 compressors per refrigerant circuit.	IRC	frequenzumrichter für die Drehzahlregelung der Kompressoren. Die Kompressoren können in einem Bereich von 40 Hz bis 60 Hz betrieben werden. Beinhaltet ebenfalls die Option DC für Geräte mit zwei Kompressoren je Kältekreislauf im Standard
Inverter control for pump (to combine with WP). Control based on constant pressure. Pump allowed to work in the range from 30Hz to 50Hz.	IRP	Frequenzumrichter für Einzel-Pumpen (in Verbindung mit WP). Druckgeregelt, erlaubt einen Frequenzbereich von 30 bis 50 Hz
Inverter control for double pump (to combine with DP). Control based on constant pressure. Pump allowed to work in the range from 30Hz to 50Hz.	IRDPP	frequenzumrichter für Doppel-Pumpen (in Verbindung mit DP). Druckgeregelt, erlaubt einen Frequenzbereich von 30 bis 50 Hz. Der Preis dieser Option ist zwei mal der Preis von IRP
Inverter control for pump (to combine with PH). Control based on constant pressure. Pump allowed to work in the range from 30Hz to 50Hz.	IRPH	Frequenzumrichter für Einzel-Pumpen (in Verbindung mit PH). Druckgeregelt, erlaubt einen Frequenzbereich von 30 bis 50 Hz
Inverter control for double pump (to combine with DPH). Control based on constant pressure. Pump allowed to work in the range from 30Hz to 50Hz.	IRDPPH	Frequenzumrichter für Doppel-Pumpen (in Verbindung mit DPH). Druckgeregelt, erlaubt einen Frequenzbereich von 30 bis 50 Hz. Der Preis dieser Option ist zwei mal der Preis von IRPH
Electrical components designed for ambient temperature 45°C. Electrical board ventilation included. Unloading function enabled in case of 2 or 3 compressors per refrigerant circuit (unloading function allows the chiller to work in high ambient temperature by switching off one compressor to prevent the high pressure alarm). Please check with selection software if the chiller is able to work with ambient temperature up to 45°C.	TR45	Elektrische Komponenten für Umgebungstemperatur bis 45 °C. Inklusive Schaltschranklüfter. Lastabwurf bei 2 oder 3 Kompressoren pro Kältemittelkreislauf (Lastabwurf ermöglicht es dem Kühler, bei hoher Umgebungstemperatur zu arbeiten, indem ein Kompressor abgeschaltet wird, um eine Hochdruckstörung zu verhindern). Bitte überprüfen Sie mit der Auswahlsoftware, ob der Kühler für Umgebungstemperatur bis 45 °C geeignet ist.
Electrical components designed for ambient temperature 50°C. Electrical board ventilation included. EC fans needed if fans speed regulation is required. Unloading function enabled in case of 2 or 3 compressors per refrigerant circuit (unloading function allows the chiller to work in high ambient temperature by switching off one compressor to prevent the high pressure alarm). Please check with selection software if the chiller is able to work with ambient temperature up to 50°C.	TR50	Elektrische Komponenten für Umgebungstemperatur bis 50 °C. Inklusive Schaltschranklüfter. Lastabwurf bei 2 oder 3 Kompressoren pro Kältemittelkreislauf (Lastabwurf ermöglicht es dem Kühler, bei hoher Umgebungstemperatur zu arbeiten, indem ein Kompressor abgeschaltet wird, um eine Hochdruckstörung zu verhindern). Bitte überprüfen Sie mit der Auswahlsoftware, ob der Kühler für Umgebungstemperatur bis 50 °C geeignet ist.

Description	abbr.	Beschreibung
Heater for electrical board. Recommended if the chiller is required to work with ambient temperature lower than -20°C	EB	Schaltschrankheizung. Wird empfohlen, wenn der Kühler bei Raumtemperaturen unter -20°C arbeiten muss.
Electrical board ventilation. Recommended if the chiller is required to work with ambient temperature higher than 40°C	EV	Schaltschrankbelüftung. Wird empfohlen, wenn der Kühler bei Raumtemperaturen über 40°C arbeiten muss.
Transparent cover for display protection. Recommended for outdoor use	PD	Durchsichtige Hülle zum Schutz des Displays. Wird empfohlen bei Verwendung in Außenräumen
Capacitors to allow power factor correction up to 0.95	PFC	Koppler, um eine Stromfaktorkorrektur bis zu 0.95 zu erlauben
Closed electrical cabinet with airconditioning to protect the electrical components from corrosive atmosphere. Recommended with aggressive atmosphere. Not available with remote inverters for compressors, pumps or fans	EL	Geschlossener Schaltschrank mit Klimaanlage, um die elektrischen Bauteile vor korrosiven Atmosphären zu schützen. Wird empfohlen bei aggressiven Atmosphären. Nicht verfügbar mit Remote-Umrichter für Kompressoren, Pumpen oder Ventilatoren.
Acoustic and visual alarm mounted on the top of the chiller. It takes action in case of general alarm.	VAL	Akustischer und visueller Alarmmelder oben am Kühler. Die Vorrichtung schaltet sich bei allgemeinem Alarm ein.
Chiller without neutral	SN	Kühler ohne Neutralleiter
PACKING		VERPACKUNG
Full cardboard protection (models from 003 to 055) with wooden spacers on bottom (models 001, 002 and from 030 to 055) or vertical cardboard protection on unit corners, nylon covering and wooden spacers on bottom (models from 061 to 480).	NCC	Schutzkarton (Modelle von 003 bis 055) mit Abstandshaltern aus Holz auf der Unterseite (Modelle 001, 002 und von 030 bis 055) oder vertikalem Kantenschutz aus Wellpappe, Nylonabdeckung und Abstandshaltern aus Holz auf der Unterseite (Modelle von 061 bis 480).
Pallet ISPM15. Recommended for shipment	PLT	Paletten ISPM15. Empfohlen für den Versand
Rubber pad antivibrating (shipment)	ANS	Vibrationsdämmende Gummi-Unterlage (Versand)
Wooden cage ISPM15. Recommended for groupage shipment	WCA	Holzgestell ISPM15. Empfohlen für den Sammelwarenversand
Wooden crate ISPM15. Recommended for groupage shipment as an alternative to WCA	WCR	Holzgestell ISPM15. Empfohlen bei Sammelwarenversand alternativ zu WCA

15 Technical data

15 Technische Daten

ENR SERIES

Process Cooling Application		Aircooled liquid chillers ENR series, scroll compressors, plate / coaxial evaporator, condenser with copper tubes, aluminium finned core and axial fans											
Luftgekühlte Kältemaschinen ENR Serie, Scroll Kompressoren R410A, Plattenverdampfer / Koaxialverdampfer, Kondensatoren mit Kupfer Leitungen, Aluminiumrippen aus Aluminium und Axial-Ventilatoren		Model	001	002	003	004	005	008	010	012	016	018	022
Industriellen Kühlung													
NENNKÄLTELEISTUNG (1)		kW	1.6	2.1	3.6	4.2	5.5	7.6	9.3	12.2	13.5	18	22.0
TOTAL COOLING CAPACITY (1)		kW	0.5	0.7	1.2	1.4	1.8	2.9	3.4	3.9	5.2	5.8	6.7
NENNLEISTUNGS-AUFNAHME VERDICHTER(1)		kW	2.97	2.69	2.79	2.82	2.89	2.77	2.55	2.78	2.37	2.78	2.93
EER			4.7	4.6	4.7	4.9	4.8	4.6	4.6	4.7	4.8	4.7	4.9
SEPR (HT) (5)		nr.	1	1	1	1	1	1	1	1	1	1	1
COMPRESSORS		nr.	1	1	1	1	1	1	1	1	1	1	1
REFRIGERATING CIRCUITS		nr.	1	1	1	1	1	1	1	1	1	1	1
PARTITION STEP		nr.	1	1	1	1	1	1	1	1	1	1	1
REFRIGERANT		R	R410A										
HYDRAULIC SECTION													
NOMINAL WATER FLOW		m ³ /h	0.3	0.4	0.6	0.7	0.9	1.4	1.6	2.1	2.3	3.1	3.8
WATER FLOW RANGE		m ³ /h	0.3 + 2	0.3 + 2	0.6 + 2.2	0.6 + 2.2	0.8 + 2.2	1.2 + 2.4	1.4 + 3	1.2 + 2.9	1.2 + 2.9	2.5 + 5	3 + 6
TYPE OF EVAPORATOR		Plate evaporator / Plattenverdampfer	Self-cleaning coaxial evaporator / Selbstreinigendes Koaxial Verdampfer										
EVAPORATOR PRESSURE DROP		kPa	20	22	22	23	23	26	25	27	28	28	31
AVAILABLE PRESSURE		kPa	301	284	279	269	252	262	270	263	264	249	241
MAXIMUM PUMP ABSORBED POWER		kW	0.56	0.56	0.56	0.56	0.56	0.98	0.98	0.98	0.98	0.98	1.28
MAXIMUM PUMP ABSORBED CURRENT		A	3.46	3.46	3.46	3.46	3.46	1.78	1.78	1.78	1.78	1.78	2.37
AVAILABLE PRESSURE		kPa	-	-	431	421	401	611	593	562	492	570	518
MAXIMUM PUMP ABSORBED POWER		kW	-	-	0.74	0.74	0.74	1.10	1.10	1.10	1.10	1.47	1.47
MAXIMUM PUMP ABSORBED CURRENT		A	-	-	3.22	3.22	3.22	2.17	2.17	2.17	2.17	2.86	2.86
HYDRAULIC CONNECTIONS		BSP/DN	1/2"	1/2"	3/4"	3/4"	3/4"	1"	1"	1"	1"	1"	1"
TANK VOLUME		dm ³	10	10	40	40	40	50	50	50	50	110	110
EXPANSION VESSEL VOLUME (3)		liters	N.A.										
FAN SECTION (AXIAL)													
TOTAL AIR FLOW		m ³ /h	700	650	1300	1200	1500	4100	4100	4750	4750	6500	7400
FANS		nr.	1	1	1	1	1	1	1	1	1	1	1
FANS ABSORBED POWER		kW	0.07	0.11	0.09	0.09	0.10	0.25	0.25	0.49	0.49	0.68	0.81
FANS ABSORBED CURRENT		A	0.4	0.8	0.4	0.4	0.5	1.1	1.1	2.4	2.4	3.0	1.5
TOTAL ELECTRIC DATA													
NOMINAL ABSORBED POWER (4)		kW	1.1	1.4	1.9	2.1	2.5	3.8	4.6	5.4	6.7	7.5	8.8
NOMINAL ABSORBED CURRENT (F.L.A.) (4)		A	6.1	7.5	9.6	10.5	12.5	10.1	10.5	13	13.9	18.8	19.8
MAXIMUM ABSORBED CURRENT (L.R.A.) (4)		A	16	21	27	40	46	50	50	71	71	75	104
MAXIMUM PEAK CURRENT (L.R.A.) (4)		V/Ph/Hz	230/1/50										
ELECTRIC FEED													
ELECTRIC FEED		V/Ph/Hz	230/1/50										
NOISE DATA													
SOUND PRESSURE (2) (4)		dB(A)	51	51	51	51	51	51	51	52	52	53	55.8
DIMENSIONS AND WEIGHT													
LENGTH		mm	445	445	600	600	600	820	820	820	820	1010	1010
WIDTH		mm	440	440	655	655	655	615	615	615	615	720	720
HEIGHT		mm	740	740	1035	1035	1035	1360	1360	1360	1360	1580	1580
WEIGHT EMPTY		kg	55	55	85	90	95	160	165	170	175	210	260
WEIGHT OPERATING		kg	65	65	125	130	135	210	210	215	220	340	390

The manufacturer reserves the right to modify specifications without notice. Der Hersteller behält sich das Recht vor, Spezifikationen ohne vorherige Ankündigung zu ändern.

Die Daten beziehen sich auf:
 (1) Inlet/Outlet water temperature = +12/+7 °C - Condenser air temperature = +35 °C; cooling factor = 0.00043 m²/kW
 (2) Sound pressure level referred to measures according to normative ISO3744, pressure level at distance of 10 m, referred to free field on reflecting surface
 (3) With option XV (expansion vessel kit)
 (4) Data referred to standard configuration WP (with pump P3)
 (5) Data comply with the European Regulation (EU) 2016/2281, referring to high temperature process chillers

ENR SERIES

Aircooled liquid chillers ENR series, scroll compressors, coaxial evaporator, condenser with copper tubes, aluminium finned core and axial fans		Luftgekühlte Kältemaschinen ENR Serie, Scroll Kompressoren R410A, Koaxialverdampfer, Kondensatoren mit Kupfer Leitungen, Lamellenrippen aus Aluminium und Axial-Ventilatoren									
Process Cooling Application		Industrialen Kühlung									
NOMINAL COOLING CAPACITY (1)	Model	030	038	045	055	061	070	075	090	100	
TOTAL COMPRESSORS NOMINAL ABSORBED POWER (1)	kW	31	37	45	55	61	67	72	88	100	
EER	kW	8,4	11,5	12,4	17,3	16,4	19,3	22,4	25,2	29,1	
SEPR (HT) (5)		3,15	2,82	3,25	2,91	3,23	2,89	2,74	3,03	3,03	
COMPRESSORS		5,11	4,59	5,28	4,80	5,01	4,78	4,75	4,91	5,01	
REFRIGERATING CIRCUITS	nr.	1	1	1	1	2	2	2	2	2	
PARTITION STEP	nr.	1	1	1	1	1	1	1	1	1	
REFRIGERANT	nr.	1	1	1	1	1/1	1/1	1/1	1/1	1/1	
KÄLTEMITTEL	R	R410A									
HYDRAULIC SECTION											
NOMINAL WATER FLOW	m3/h	5,3	6,4	7,7	9,5	10,5	11,5	12,4	15,1	17,2	
WATER FLOW RANGE	m3/h	4 + 6	6 + 12	6 + 12	6 + 12	8 + 18	10 + 20	10 + 20	10 + 20	10 + 20	
TYPE OF EVAPORATOR	Self - cleaning coaxial evaporator, Selbstreinigungs Koaxial Verdampfer										
EVAPORATOR PRESSURE DROP	kPa	34	34	39	51	23	20	20	28	39	
AVAILABLE PRESSURE	kPa	218	245	236	220	220	222	205	212	197	
MAXIMUM PUMP ABSORBED POWER	kW	1,28	2,20	2,20	2,20	2,53	2,53	2,53	2,53	2,53	
MAXIMUM PUMP ABSORBED CURRENT	A	2,37	4,24	4,24	4,24	4,56	4,56	4,56	4,56	4,56	
AVAILABLE PRESSURE	kPa	422	618	577	518	469	471	471	460	445	
MAXIMUM PUMP ABSORBED POWER	kW	1,47	2,94	2,94	2,94	6,12	6,12	6,12	6,12	6,12	
MAXIMUM PUMP ABSORBED CURRENT	A	2,86	5,83	5,83	5,83	10,40	10,40	10,40	10,40	10,40	
HYDRAULIC CONNECTIONS	BSP/DN	1 1/2"	1 1/2"	1 1/2"	1 1/2"	2"	2"	2"	2"	2"	
TANK VOLUME	dm3	270	270	270	270	410	410	410	410	410	
EXPANSION VESSEL VOLUME (3)	liters	12									
FAN SECTION (AXIAL)											
TOTAL AIR FLOW	m3/h	16000	16400	15000	15600	25000	36000	36000	34000	32000	
FANS	nr.	2	2	2	2	2	2	2	2	2	
FANS ABSORBED POWER	kW	1,44	1,62	1,44	1,62	2,50	3,88	3,88	3,88	3,88	
FANS ABSORBED CURRENT	A	2,82	3,08	2,82	3,08	4,96	7,80	7,80	7,80	7,80	
TOTAL ELECTRIC DATA	IP54 protection rating, chillers suitable for outdoor installation, Schutzart IP54										
NOMINAL ABSORBED POWER (4)	kW	11,1	15,3	16,0	21,1	21,4	25,7	28,8	31,6	35,5	
MAXIMUM ABSORBED CURRENT (F.L.A.) (4)	A	24,4	31,8	37,1	43,8	48,0	56,1	61,3	72,4	78,8	
MAXIMUM PEAK CURRENT (L.R.A.) (4)	A	120	144	178	229	147	172	177	216	267	
ELECTRIC FEED	V/Ph/Hz	400/3/50									
NOISE DATA											
SOUND PRESSURE (2) (4)	dB(A)	55,3	57,5	55,8	58,8	59,1	59,2	59,3	59,5	60,3	
SOUND PRESSURE FOR LOW NOISE CONFIGURATION(2) (4)	dB(A)	54,9	55,1	55,1	55,8	58,8	58,8	58,9	58,9	59,2	
DIMENSIONS AND WEIGHT											
LENGTH	mm	1610	1610	1610	1610	2220	2220	2220	2220	2220	
WIDTH	mm	860	860	860	860	1100	1100	1100	1100	1100	
HEIGHT	mm	1540	1540	1540	1540	2100	2100	2100	2100	2100	
WEIGHT EMPTY	kg	375	390	410	500	740	765	770	785	890	
WEIGHT OPERATING	kg	675	690	710	800	1160	1185	1190	1205	1310	

Die Daten beziehen sich auf:
 (1) Inlet/Outlet water temperature = +12/+7 °C - Condenser air temperature = +35°C; fouling factor = 0.000043 m²/kW
 (2) Sound pressure level referred to measures according to normative ISO3744, pressure level at distance of 10 m, referred to free field on reflecting surface
 (3) With option XV (expansion vessel kit)
 (4) Data referred to standard configuration WP (with pump P3)
 (5) Data comply with the European Regulation (EU) 2016/2281, referring to high temperature process chillers

The manufacturer reserves the right to modify specifications without notice. Der Hersteller behält sich das Recht vor, Spezifikationen ohne vorherige Ankündigung zu ändern.

Updated on 09/01/2018

ENR SERIES

Aircooled liquid chillers ENR series, scroll compressors, shell and tube evaporator, condenser with copper tubes, aluminium finned core and axial fans		Luftgekühlte Kältemaschinen ENR Serie, Scroll Kompressoren R410A, Schale und Rohrverdampfer, Kondensatoren mit Kupfer Leitungen, Lamellenrippen aus Aluminium und Axial-Ventilatoren									
Process Cooling Application		Industriellen Kühlung									
NOMINAL COOLING CAPACITY (1)	Model	130	160	185	200	230	280	340	370	430	
NOMINAL COOLING CAPACITY (1)	kW	115	150	170	204	227	277	319	385	410	
TOTAL COMPRESSORS NOMINAL ABSORBED POWER (1)	kW	35,6	45,6	52,4	55,2	66,8	85,2	97,8	108,0	125,0	
EER		2,92	2,92	2,92	3,24	2,97	2,92	2,97	3,05	3,00	
SEPR (HT) (5)		5,02	4,59	4,94	5,45	4,87	4,84	4,94	5,14	5,07	
COMPRESSORS	VERDICHTER	4	4	4	4	4	4	4	4	4	
REFRIGERATING CIRCUITS	KÄLTEKREISLÄUFE	2	2	2	2	2	2	2	2	2	
PARTITION STEP	LEISTUNGSSTUFEN	2/2	2/2	2/2	2/2	2/2	2/2	2/2	2/2	2/2	
REFRIGERANT	KÄLTEMITTEL	R410A									
HYDRAULIC SECTION											
NOMINAL WATER FLOW	VOLUMENS TROM	19,8	25,8	29,2	35,1	39,0	47,6	54,9	62,8	70,5	
WATER FLOW RANGE	WASSERDURCHSATZ	14 + 27 15,4 + 31 17,5 + 35 25 + 46 25 + 46 31 + 58 38 + 70 45 + 80 52 + 100									
TYPE OF EVAPORATOR	VERDAMPFERTYP	Shell and tube evaporator, Schale und Rohrverdampfer									
EVAPORATOR PRESSURE DROP	VERDAMPFER DRUCKVERLUST	54	54	55	48	56	56	48	55	61	
AVAILABLE PRESSURE	BETRIEBSDRUCK	211	207	201	265	249	249	245	234	220	
MAXIMUM PUMP ABSORBED POWER	LEISTUNGS-AUFNAHME PUMPE	4,56	4,56	4,56	8,30	8,30	8,30	8,30	8,30	10,20	
MAXIMUM PUMP ABSORBED CURRENT	STROM-AUFNAHME PUMPE	8	8	8	14	14	14	14	14	17	
AVAILABLE PRESSURE	BETRIEBSDRUCK	449	443	438	482	475	469	469	450	414	
MAXIMUM PUMP ABSORBED POWER	LEISTUNGS-AUFNAHME PUMPE	10,20	10,20	10,20	16,22	16,22	16,22	16,22	16,22	19,94	
MAXIMUM PUMP ABSORBED CURRENT	STROM-AUFNAHME PUMPE	17	17	17	27	27	27	27	27	33	
HYDRAULIC CONNECTIONS	WASSERANSCHLÜSSE	BSP/DN	DN65	DN65	DN125	DN125	DN125	DN125	DN150	DN150	
TANK VOLUME	WASSERINHALT	390	390	390	390	500	500	500	500	500	
EXPANSION VESSEL VOLUME (3)	EXPANSION BEHALTERVOLUMEN (3)	19 liters									
FAN SECTION (AXIAL)											
TOTAL AIR FLOW	NENNLUFTMENGE	40000	57000	54000	68000	91000	90000	85000	102000	96000	
FANS	ANZAHL LÜFTER	2	3	3	4	5	5	5	6	6	
FANS ABSORBED POWER	LEISTUNG LÜFTER	3,88	5,82	5,82	7,76	9,70	9,70	9,70	11,64	11,64	
FANS ABSORBED CURRENT	LÜFTER STROM-AUFNAHME	7,80	11,70	11,70	15,60	19,50	19,50	19,50	23,40	23,40	
TOTAL ELECTRIC DATA											
NOMINAL ABSORBED POWER (4)	LEISTUNGS-AUFNAHME (OHNE PUMPE) (4)	44,0	56,0	62,8	71,3	84,8	103,2	115,8	129,8	146,8	
MAXIMUM ABSORBED CURRENT (F.L.A.) (4)	MAX. BETRIEBSSTROM (F.L.A.) (4)	92,5	117,3	139,5	162,6	179,4	212,0	241,4	278,0	307,0	
MAXIMUM PEAK CURRENT (L.R.A.) (4)	MAX. ANLAUFSTROM (L.R.A.) (4)	191,2	232,9	283,5	351,1	367,9	439,4	492,1	528,7	641,2	
ELECTRIC FEED											
V/Ph/Hz 400/3/50											
NOISE DATA											
SOUND PRESSURE (2) (4)	SCHALLDRUCKLEISTUNG(2) (4)	59,5	61,1	61,4	63,1	64,3	65,7	65,7	66,1	67,5	
SOUND PRESSURE FOR LOW NOISE CONFIGURATION(2) (4)	SCHALLDRUCK FÜR GERINGE GERÄUSCHKONFIGURATION (2) (4)	58,9	60,5	60,6	62,0	63,0	63,7	63,7	64,2	65,1	
DIMENSIONS AND WEIGHT											
LENGTH	LÄNGE	3355	3355	3355	4355	5350	5350	5350	6350	6350	
WIDTH	BREITE	1105*	1105*	1105*	1105**	1105	1105	1105	1105	1105	
HEIGHT	HOHE	2180	2180	2180	2180	2180	2180	2180	2180	2180	
WEIGHT EMPTY	LEERGEWICHT	1190	1260	1320	1815	2105	2240	2415	2745	2810	
WEIGHT OPERATING	BETRIEBSGEWICHT (OHNE PUMPE UND OHNE WASSERINHALT)	1610	1695	1760	2275	2660	2800	2995	3345	3421	
The manufacturer reserves the right to modify specifications without notice. Der Hersteller behält sich das Recht vor, Spezifikationen ohne vorherige Ankündigung zu ändern.											

Data referred to :

- (1) Inlet/Outlet water temperature = +12/+7 °C - Condenser air temperature = +35°C; fouling factor = 0.000043 m²K/W
- (2) Sound pressure level referred to measures according to normative ISO3744, pressure level at distance of 10 m, referred to free field on reflecting surface
- (3) With option XV (expansion vessel kit)
- (4) Data referred to standard configuration, WP (with pump P3)
- (5) Data comply with the European Regulation (EU) 2016/2281, referring to high temperature process chillers
- * Note: with double pump P5 (DPH option) the chiller width is 1305mm
- ** Note: with double pump (DP and DPH option) the chiller width is 1305mm
- (1) Wassereintrittstemperatur/Wasseraustrittstemperatur = +12/+7 °C -Umgebungstemperatur = +35°C; Verschmutzungsfaktor = 0.000043 m²K/W
- (2) Schalldruckpegel Maßnahmen nach normative ISO3744, Druckniveau bei einem Abstand von 10 m, bezogen auf freiem Feld auf reflektierender Oberfläche bezeichnet
- (3) Mit der option XV (ausdehnungsgefäß-set)
- (4) Die Daten beziehen sich auf Standardkonfiguration WP (mit Pumpe P3)
- (5) Die Daten entsprechen der Europäischen Verordnung (EU) 2016/2281 und beziehen sich auf Hochtemperaturprozesskühler
- * Hinweis: mit Doppel-Pumpe P5 (DPH Option) beträgt die Breite des Gerätes 1305 mm
- ** Hinweis: mit Doppel-Pumpe (DP und DPH Option) beträgt die Breite des Gerätes 1305 mm

Updated on 09/07/2018

ENRF SERIES

Free cooling chillers ENRF series, scroll compressors R410A / R32, coaxial evaporator, condenser with copper tubes and aluminium finned core and axial fans
 Luftgekühlte Kältemaschinen ENRF Serie, Scroll Kompressoren R410A / R32, Koaxialverdampfer, Kondensatoren mit Kupfer Leitungen, Lamellenrippen aus Aluminium und Axial-Ventilatoren

Process Cooling Application		Industriellen Kühlung									
	Model	022	030	038	045	055	061	070	075	090	
NOMINAL COOLING CAPACITY (1)	kW	23.4	29.8	39	45	58	60	70	75	87	
TOTAL COMPRESSORS NOMINAL ABSORBED POWER (1)	kW	6.8	8.4	10.4	12.3	16.1	16.1	18.2	21.1	25.0	
EER	(1)	2.77	2.97	2.72	2.78	2.90	3.01	3.17	3.00	2.82	
SEPR (HT) (6)	(1)	5.5	5.4	5.7	5.6	5.6	6.1	6.1	5.8	5.8	
AIR TEMPERATURE 100% FREE COOLING (1)	°C	0.7	0.1	2.0	1.0	0.5	2.5	2.2	1.7	2.0	
NOMINAL COOLING CAPACITY (2)	kW	24.6	30.6	40	46	60	61	71	78	91	
TOTAL COMPRESSORS NOMINAL ABSORBED POWER (2)	kW	6.7	8.5	10.6	12.3	16.3	16.3	18.7	21.2	25.0	
EER	(2)	3.0	3.02	2.73	2.86	2.96	2.97	3.16	3.12	2.95	
AIR TEMPERATURE 100% FREE COOLING (2)	°C	3.2	2.4	4	3	2	4	4	4	4	
COMPRESSORS / REFRIGERATING CIRCUITS / PARTITION STEP	nr.	1/1/1	1/1/1	1/1/1	1/1/1	2/1/2	2/1/2	2/1/2	2/1/2	2/1/2	
HYDRAULIC SECTION											
Self - cleaning coaxial evaporator, Selbstreinigungs Koaxial Verdampfer											
NOMINAL WATER FLOW	m³/h	4.0	5.1	6.7	7.7	10.0	10.3	12.0	12.9	15.0	
WATER FLOW RANGE	m³/h	4-8	4-8	6-12	6-12	6-12	8.6-19	10-22	10-22	10-22	
EVAPORATOR PRESSURE DROP (4)	kPa	49	47	56	58	60	33	33	26	42	
FREE COOLING PRESSURE DROP (5)	kPa	75	76	74	82	107	58	63	60	85	
AVAILABLE PRESSURE	kPa	196	179	204	193	162	235	230	233	208	
MAXIMUM PUMP ABSORBED POWER	kW	1.28	1.28	2.20	2.20	2.20	3.46	3.46	3.46	3.46	
MAXIMUM PUMP ABSORBED CURRENT	A	2.37	2.37	4.24	4.24	4.24	6.33	6.33	6.33	6.33	
AVAILABLE PRESSURE	kPa	473	606	571	534	444	434	428	545	516	
MAXIMUM PUMP ABSORBED POWER	kW	1.47	2.94	2.94	2.94	2.94	6.12	6.12	8.30	8.30	
MAXIMUM PUMP ABSORBED CURRENT	A	2.86	5.83	5.83	5.83	5.83	10.40	10.40	14.10	14.10	
HYDRAULIC CONNECTIONS	BSP/DN	1 1/2"	1 1/2"	1 1/2"	1 1/2"	1 1/2"	2"	2"	2"	2"	
TANK VOLUME	dm³	270	270	270	270	270	410	410	410	410	
EXPANSION VESSEL VOLUME (6)											
lites											
AXIAL VENTILATOREN											
RV "fan speed cut-phase regulator" included, RV inklusive											
TOTAL AIR FLOW	m³/h	13800	13000	30000	30000	28000	36000	36000	36000	49500	
FANS	nr.	2	2	2	2	2	2	2	2	3	
FANS ABSORBED POWER	kW	1.62	1.62	3.88	3.88	3.88	3.88	3.88	3.88	5.82	
FANS ABSORBED CURRENT	A	3.08	3.08	7.80	7.80	7.80	7.80	7.80	7.80	11.70	
TOTAL ELECTRIC DATA											
NOMINAL ABSORBED POWER (7)	kW	9.7	11.3	16.5	18.4	22.2	23.4	25.6	28.4	34.3	
MAXIMUM ABSORBED CURRENT (F.L.A.) (7)	A	21.4	24.7	36.5	42.0	48.5	52.6	57.8	63.1	78.0	
MAXIMUM PEAK CURRENT (L.R.A.) (7)	A	102.4	120.4	144.2	178.2	229.2	151.4	173.4	178.6	222.0	
ELECTRIC FEED											
V/Ph/Hz											
ELEKTRISCHE EINSPEISUNG											
400/3/50											
GERÄUSCHE											
SOUND PRESSURE (3) (7)	dB(A)	57.3	57.3	59.0	59.1	59.9	59.1	59.2	59.3	60.8	
SOUND PRESSURE FOR LOW NOISE CONFIGURATION(3) (7)	dB(A)	57.1	57.1	58.8	58.8	59.1	58.8	58.8	58.9	60.4	
ABMESSUNGEN UND GEWICHT											
LENGTH	mm	1610	1610	2220	2220	2220	3355	3355	3355	3355	
WIDTH	mm	860	860	1100	1100	1100	1105	1105	1105	1105	
HEIGHT	mm	1540	1540	2100	2100	2100	2180	2180	2180	2180	
WEIGHT EMPTY	kg	460	470	635	650	740	1120	1125	1150	1180	
WEIGHT OPERATIVE	kg	745	755	930	950	1035	1590	1595	1620	1650	

Die Daten beziehen sich auf:
 (1) Inlet/Outlet water temperature = +12/+7 °C - Condenser air temperature = +35°C; fouling factor = 0.000043 m²K/W
 (2) Inlet/Outlet water temperature = +15/+10 °C - Condenser air temperature = +30°C; 30% Ethylene Glycol
 (3) Sound pressure level referred to measures according to normative ISO3744, pressure level at distance of 10 m, referred to free field on reflecting surface
 (4) Evaporator + valve + piping pressure drop (no free cooling)
 (5) Free cooling coil + evaporator + pipe + piping pressure drop
 (6) With option XY (expansion vessel kit)
 (7) Data related to standard configuration WP (with pump P3)

Notes:
 (1) Inlet/Outlet water temperature = +12/+7 °C - Condenser air temperature = +35°C; fouling factor = 0.000043 m²K/W
 (2) Inlet/Outlet water temperature = +15/+10 °C - Condenser air temperature = +30°C; 30% Ethylene Glycol
 (3) Sound pressure level referred to measures according to normative ISO3744, pressure level at distance of 10 m, referred to free field on reflecting surface
 (4) Evaporator + valve + piping pressure drop (no free cooling)
 (5) Free cooling coil + evaporator + pipe + piping pressure drop
 (6) With option XY (expansion vessel kit)
 (7) Data related to standard configuration WP (with pump P3)

The manufacturer reserves the right to modify specifications without notice. Der Hersteller behält sich das Recht vor, Spezifikationen ohne vorherige Ankündigung zu ändern.

Updated on 26/09/2018

ENRF SERIES

Free cooling chillers ENRF series, scroll compressors R410A / R32, coaxial (CX) / shell and tube evaporator, condenser with copper tubes and aluminium finned core and axial fans
Luftgekühlte Kältemaschinen ENRF Serie, Scroll Kompressoren R410A, Koaxialverdampfer (CX) / Schale und Rohrverdampfer, Kondensatoren mit Kupfer / Leitungen Lamellenrippen aus Aluminium und Axial-Ventilatoren

Process Cooling Application		Industriellen Kühlung												
		Model												
		100	130	160	185	200	230	280	340	370				
NOMINAL COOLING CAPACITY (1)		kW												
TOTAL COMPRESSORS NOMINAL ABSORBED POWER (1)		kW												
EER		(1)												
SEPR (HT) (8)		SEPR (HT) (8)												
AIR TEMPERATURE 100% FREE COOLING (1)		°C												
NOMINAL COOLING CAPACITY (2)		kW												
TOTAL COMPRESSORS NOMINAL ABSORBED POWER (2)		kW												
EER		(2)												
AIR TEMPERATURE 100% FREE COOLING (2)		°C												
COMPRESSORS / REFRIGERATING CIRCUITS / PARTITION STEP		nr.												
HYDRAULIC SECTION		CX												
NOMINAL WATER FLOW		m ³ /h												
WATER FLOW RANGE		m ³ /h												
EVAPORATOR PRESSURE DROP (4)		kPa												
FREE COOLING PRESSURE DROP (5)		kPa												
AVAILABLE PRESSURE		kPa												
MAXIMUM PUMP ABSORBED POWER		kW												
MAXIMUM PUMP ABSORBED CURRENT		A												
AVAILABLE PRESSURE		kPa												
MAXIMUM PUMP ABSORBED POWER		kW												
MAXIMUM PUMP ABSORBED CURRENT		A												
HYDRAULIC CONNECTIONS		BSP/DIN 2"												
TANK VOLUME		dm ³												
EXPANSION VESSEL VOLUME (6)		liters												
FAN SECTION (AXIAL)		RV "fan speed cut-phase regulator" included, RV inklusive												
TOTAL AIR FLOW		m ³ /h												
FANS		nr.												
FANS ABSORBED POWER		kW												
FANS ABSORBED CURRENT		A												
TOTAL ELECTRIC DATA		IP54 protection rating, chillers suitable for outdoor installation, Schutzart IP54												
NOMINAL ABSORBED POWER (6)		kW												
MAXIMUM ABSORBED CURRENT (F.L.A.) (6)		A												
MAXIMUM PEAK CURRENT (L.R.A.) (6)		A												
ELECTRIC FEED		V/Ph/Hz												
NOISE DATA														
SOUND PRESSURE (3) (7)		dB(A)												
SOUND PRESSURE FOR LOW NOISE CONFIGURATION(3) (7)		dB(A)												
DIMENSIONS AND WEIGHT														
LENGTH		mm												
WIDTH		mm												
HEIGHT		mm												
WEIGHT EMPTY		kg												
WEIGHT OPERATIVE		kg												

Die Daten beziehen sich auf:
 (1) Wassereintrittstemperatur/Wasseraustrittstemperatur = +12/+7 °C-Umgebungstemperatur = +35°C;
 Verschmutzungsfaktor = 0,000043 m²/Kw
 (2) Wassereintrittstemperatur/Wasseraustrittstemperatur = +15/+10 °C-Umgebungstemperatur = +30°C, 30% ethylen glycol
 (3) Schalldruckpegel Maßnahmen nach normative ISO3744, Druckniveau bei einem Abstand von 10 m,
 bezogen auf freiem Feld auf reflektierender Oberfläche bezeichnet
 (4) Verdampfer + Ventile + Druckverlust über Verdampfer + Ventile + Druckverlust über Verdampfer
 (5) Freikühlung Register + Verdampfer + Ventile + Druckverlust über Verdampfer
 (6) Mit der option XV (ausdehnungsgefäß-set)
 (7) Die Daten beziehen sich auf Standard-Konfiguration WP (mit Pumpe P3)
 (8) Die Daten entsprechen der Europäischen Verordnung (EU) 2016/2281 und beziehen sich auf Hochtemperaturprozesskühler
 * In den Ausführungen NT, NP, NT, WP und NT, PH beträgt die Breite des Gerätes 1105 mm
 The manufacturer reserves the right to modify specifications without notice. Der Hersteller behält sich das Recht vor, Spezifikationen ohne vorherige Ankündigung zu ändern.
 Updated on 26/09/2018

CSE SERIES

Aircooled liquid chillers CSE series, scroll compressors R410A, coaxial / shell and tube evaporator, condenser with copper tubes and aluminium finned core and centrifugal fans.
Luftgekühlte Kältemaschinen CSE Serie, Scroll Kompressoren R410A, Koaxialverdampfer / Schale und Rohrverdampfer, Kondensatoren mit Kupfer Leitungen, Lamellenrippen aus Aluminium und Radialventilatoren

Process Cooling Application		Industriellen Kühlung											
Model	030	038	045	061	075	100	130	160	185	230	280	340	370
NOMINAL COOLING CAPACITY (1)	kW												
TOTAL COMPRESSORS NOMINAL ABSORBED POWER (1)	kW												
EER	nr.												
SEPR (HT) (6)	nr.												
COMPRESSORS	nr.												
REFRIGERATING CIRCUITS	nr.												
PARTION STEP	nr.												
REFRIGERANT	R												
HYDRAULIC SECTION													
NOMINAL WATER FLOW	m ³ /h												
WATER FLOW RANGE	m ³ /h												
TYPE OF EVAPORATOR (4)	Self-cleaning coaxial evaporator, selbstreinigender Koaxial Verdampfer												
EVAPORATOR PRESSURE DROP	kPa												
AVAILABLE PRESSURE	kPa												
MAXIMUM PUMP ABSORBED POWER	kW												
MAXIMUM PUMP ABSORBED CURRENT	A												
AVAILABLE PRESSURE	kPa												
MAXIMUM PUMP ABSORBED POWER	kW												
MAXIMUM PUMP ABSORBED CURRENT	A												
HYDRAULIC CONNECTIONS	BSP/DN												
TANK VOLUME	dm ³												
EXPANSION VESSEL VOLUME (5)	liters												
FAN SECTION (CENTRIFUGAL)													
TOTAL AIR FLOW	m ³ /h												
FANS	nr.												
FANS ABSORBED POWER	kW												
FANS ABSORBED CURRENT	A												
TOTAL ELECTRIC DATA													
NOMINAL ABSORBED POWER (3)	kW												
MAXIMUM ABSORBED CURRENT (F.L.A.) (3)	A												
MAXIMUM PEAK CURRENT (L.R.A.) (3)	A												
ELECTRIC FEED	V/Ph/Hz												
NOISE DATA													
SOUND PRESSURE (2) (3)	dB(A)												
SOUND PRESSURE FOR LOW NOISE CONFIGURATION (2) (3)	dB(A)												
DIMENSIONS AND WEIGHT													
LENGTH	mm												
WIDTH	mm												
HEIGHT	mm												
WEIGHT EMPTY	kg												
WEIGHT OPERATIVE	kg												

The manufacturer reserves the right to modify specifications without notice. Der Hersteller behält sich das Recht vor, Spezifikationen ohne vorherige Anündigung zu ändern.

Data referred to:
 (1) Inlet/Outlet water temperature = +12/+7 °C - Condenser air temperature = +32 °C; cooling factor = 0.00043 m³/kW
 (2) Sound pressure level referred to measures according to normative ISO3744, pressure level at distance of 10 m, referred to free field on reflecting surface
 (3) Data referred to model that mounts the pump P3
 (4) Stainless steel coaxial evaporator available on request
 (5) With option XV (expansion vessel kit)
 (6) Data comply with the European Regulation (EU) 2016/2281, referring to high temperature process chillers

NOTE:
 - Each model has a available pressure at air side about 200Pa
 - Chillers for indoor installation

Die Daten beziehen sich auf:
 (1) Wassereintrittstemperatur/Wasseraustrittstemperatur = +12/+7 °C - Umgebungstemperatur = +32 °C; Verschmutzungsfaktor = 0.00043 m³/kW
 (2) Schalldruckpegel Maßnahmen nach normative ISO3744, Druckniveau bei einem Abstand von 10 m, bezogen auf freiem Feld auf reflektierender Oberfläche bezeichnet
 (3) Die Daten beziehen sich auf Modell, das die Pumpe P3 montiert
 (4) Koaxial Verdampfer in Edelstahl Ausführung auf Anfrage
 (5) Mit der option XV (Ausdehnungsgefäß-set)
 (6) Die Daten entsprechen der Europäischen Verordnung (EU) 2016/2281 und beziehen sich auf Hochtemperaturprozesskühler

HINWEIS:
 - Verfügbarer Druck für die Modelle 200Pa
 - Kaltwassersätze zur Innenaufstellung

Updated on 10.01.2018

16 Working limits

The following graph shows the operating limits of the units listed below:

17 Arbeitsgrenzen

Die folgende Graphik zeigt die Arbeitsgrenzen der unten aufgelisteten Anlagen:

ENR models 001, 002, 003, 004

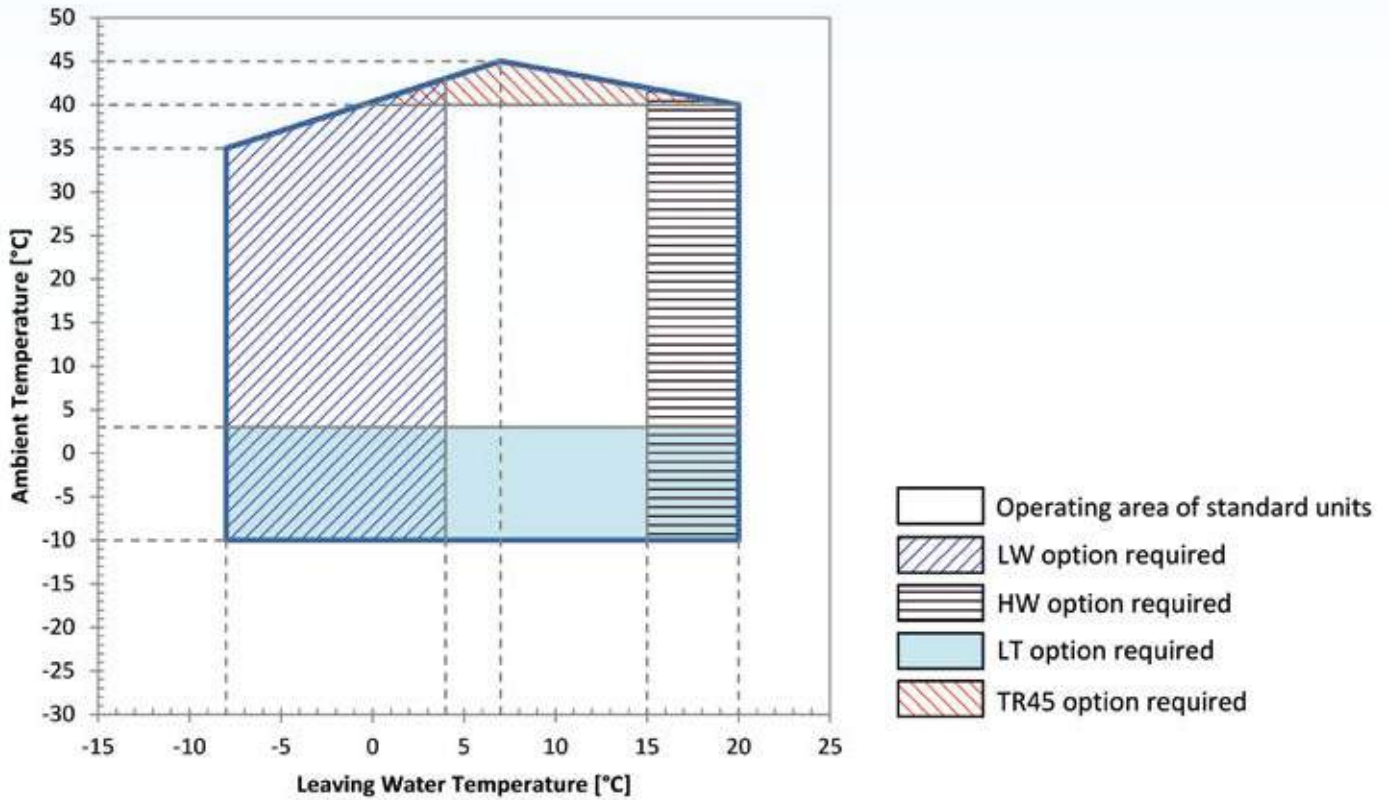

ENR models 005

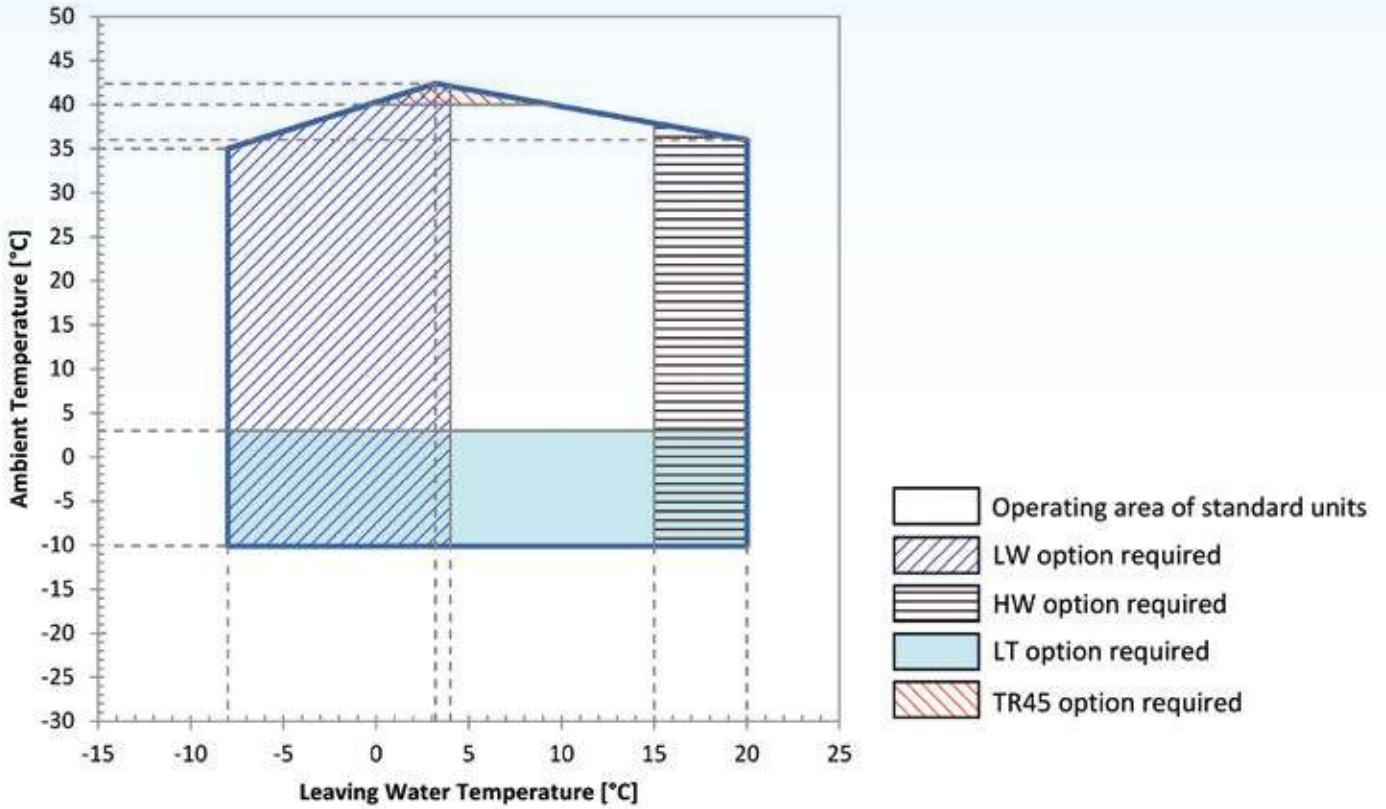

ENR models 008, 010, 012, 018

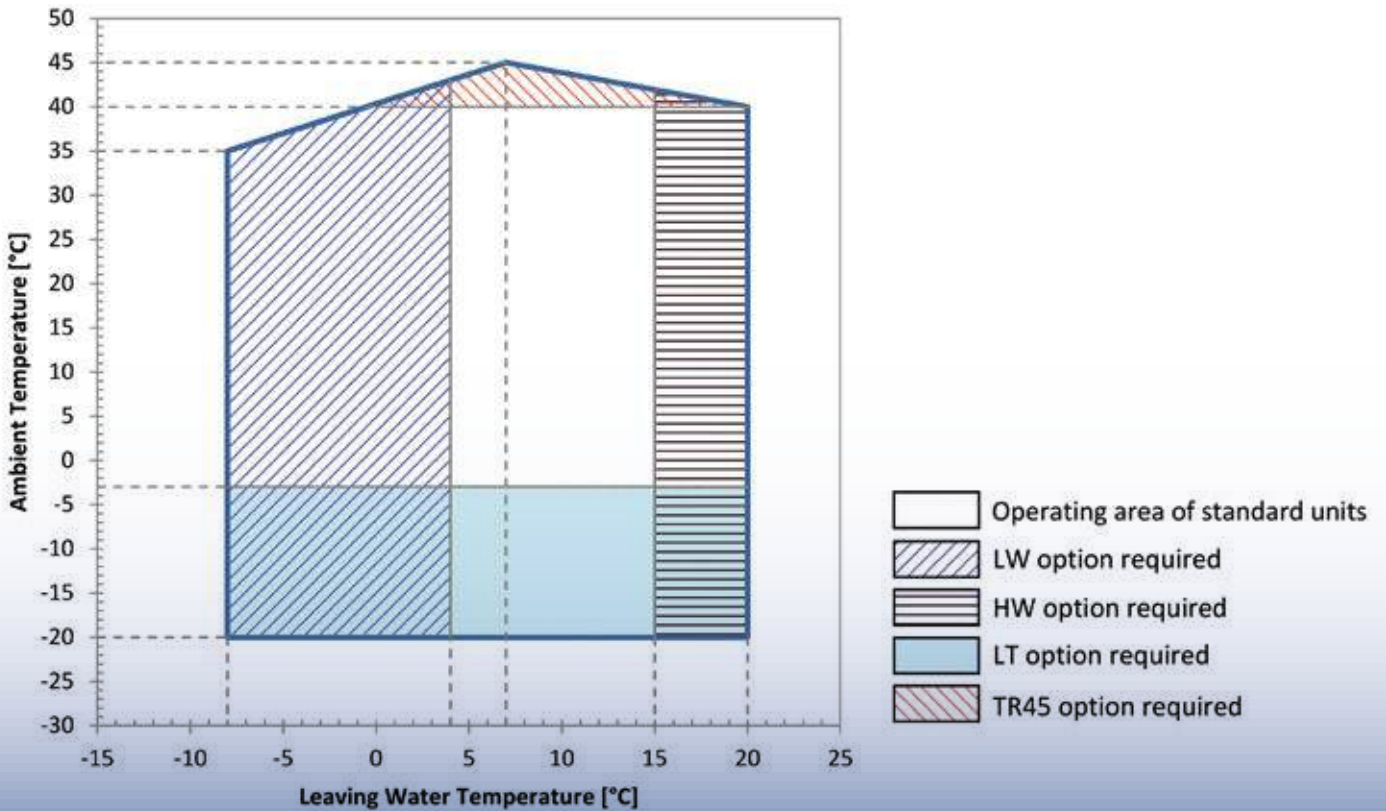

ENR models 016, 022

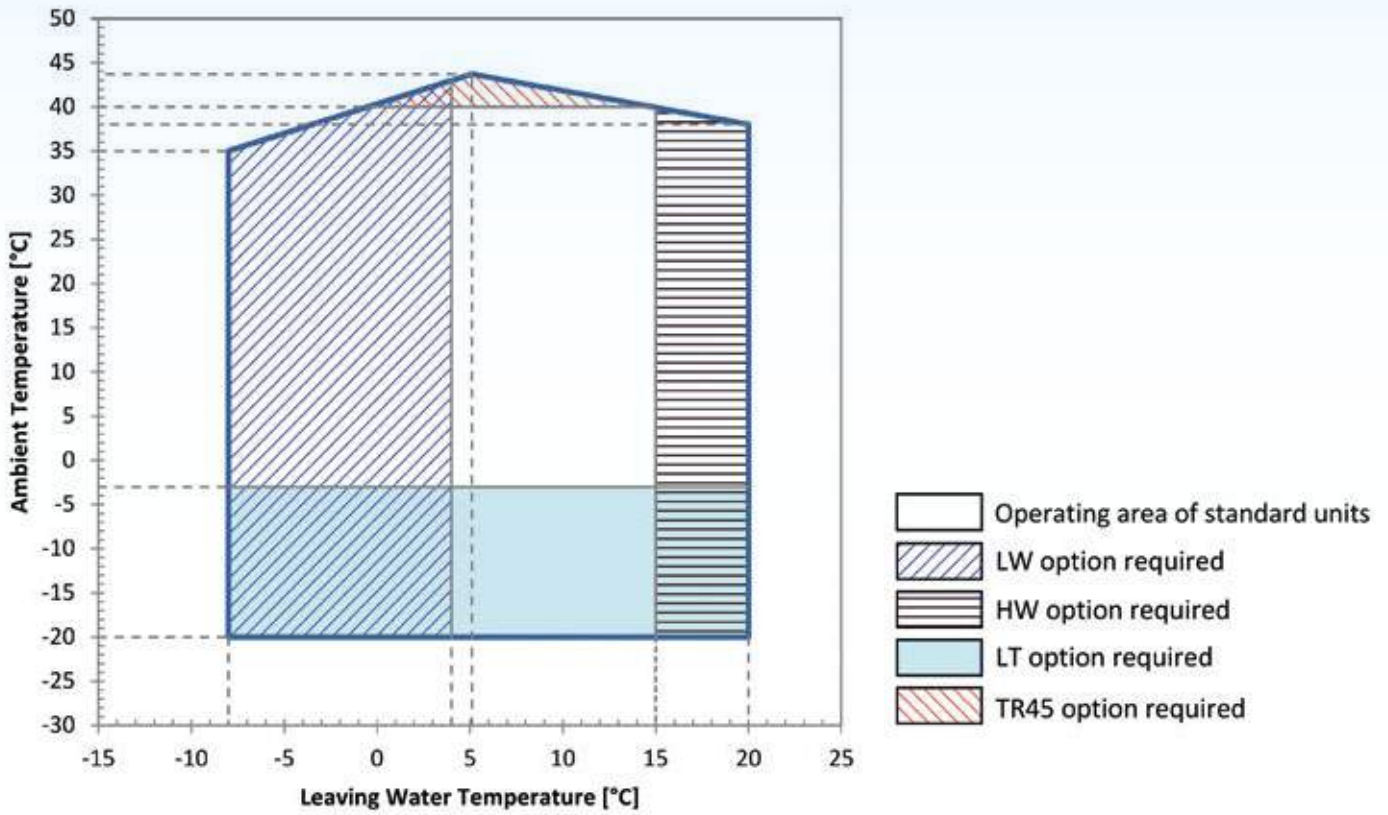



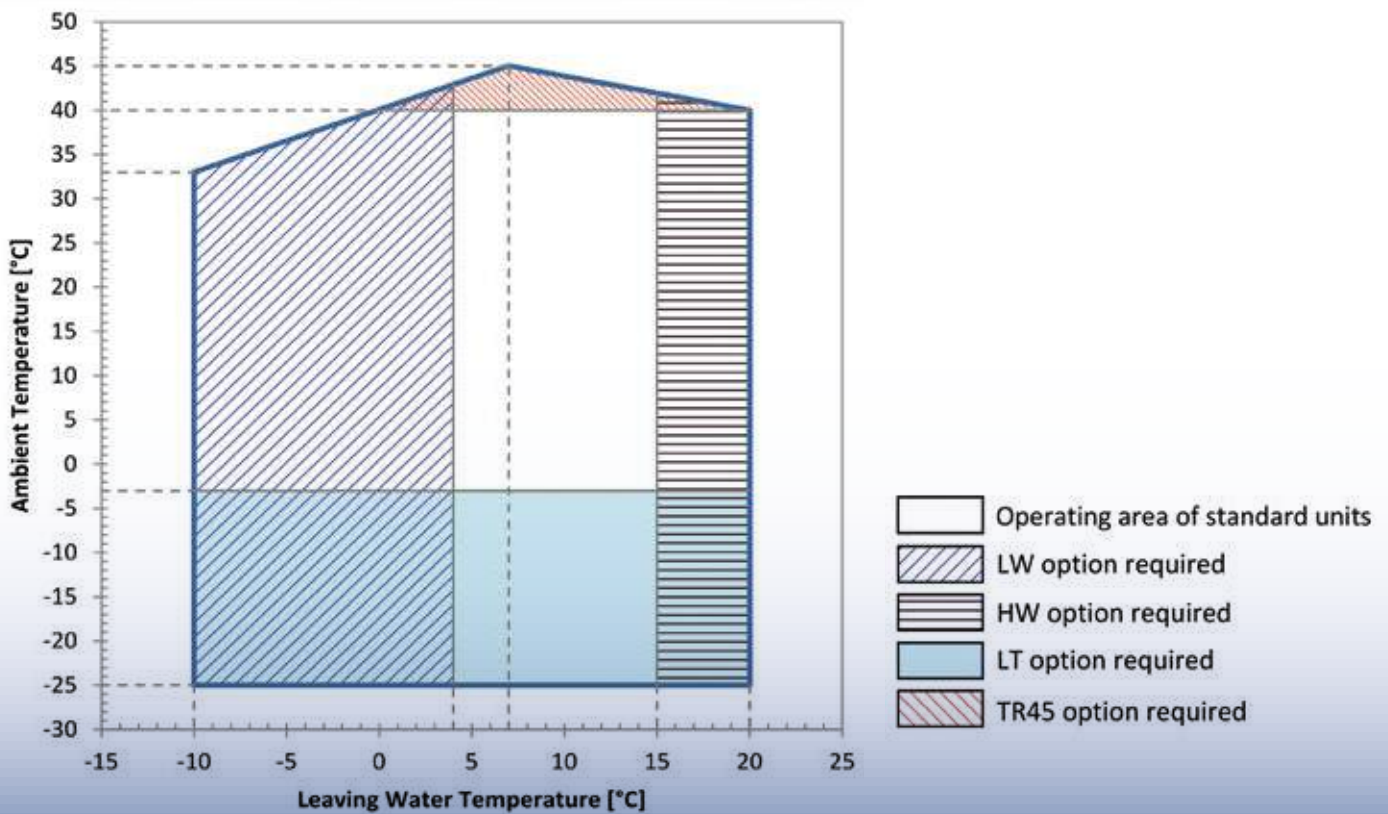

ENR models 030, 038, 045, 061, 070, 075, 090, 130, 160, 185

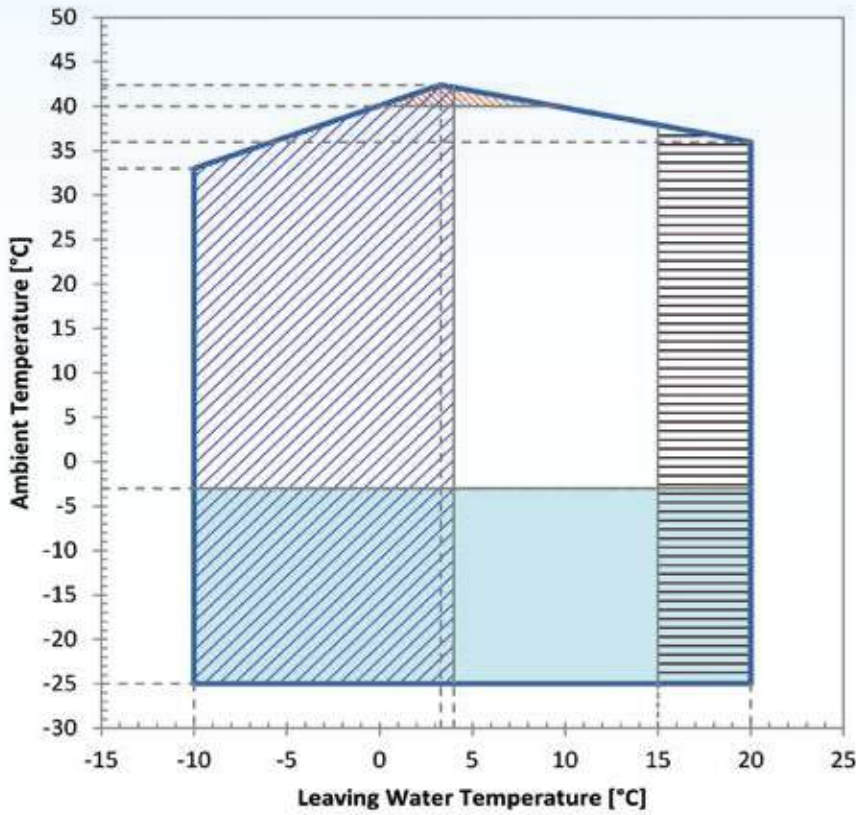







ENR models 055

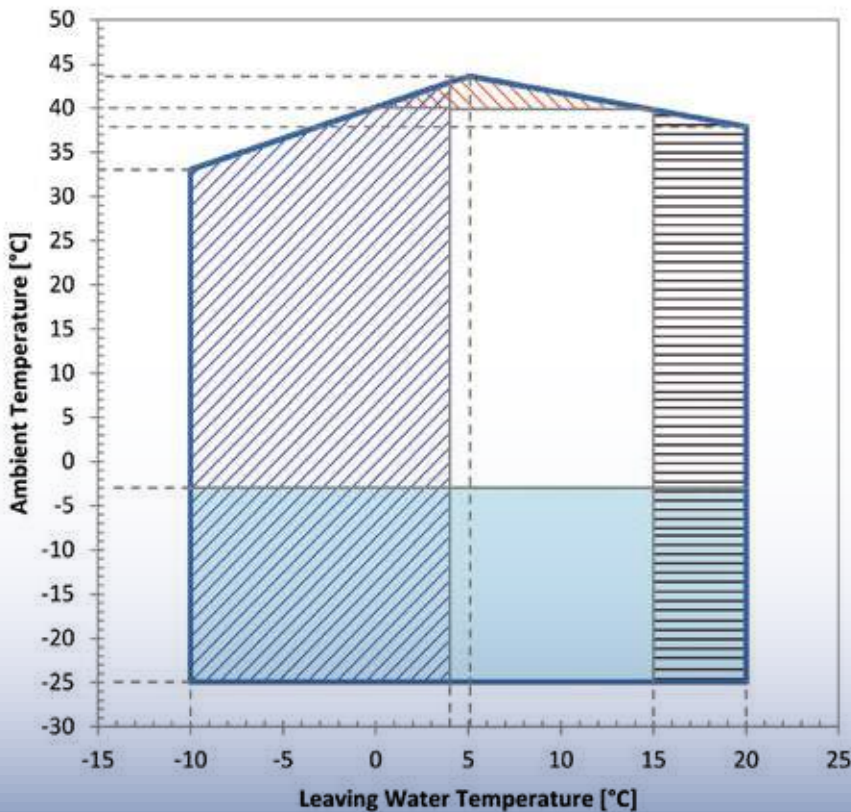

-  Operating area of standard units
-  LW option required
-  HW option required
-  LT option required
-  TR45 option required

ENR models 100



-  Operating area of standard units
-  LW option required
-  HW option required
-  LT option required
-  TR45 option required

ENR models 200, 230, 280

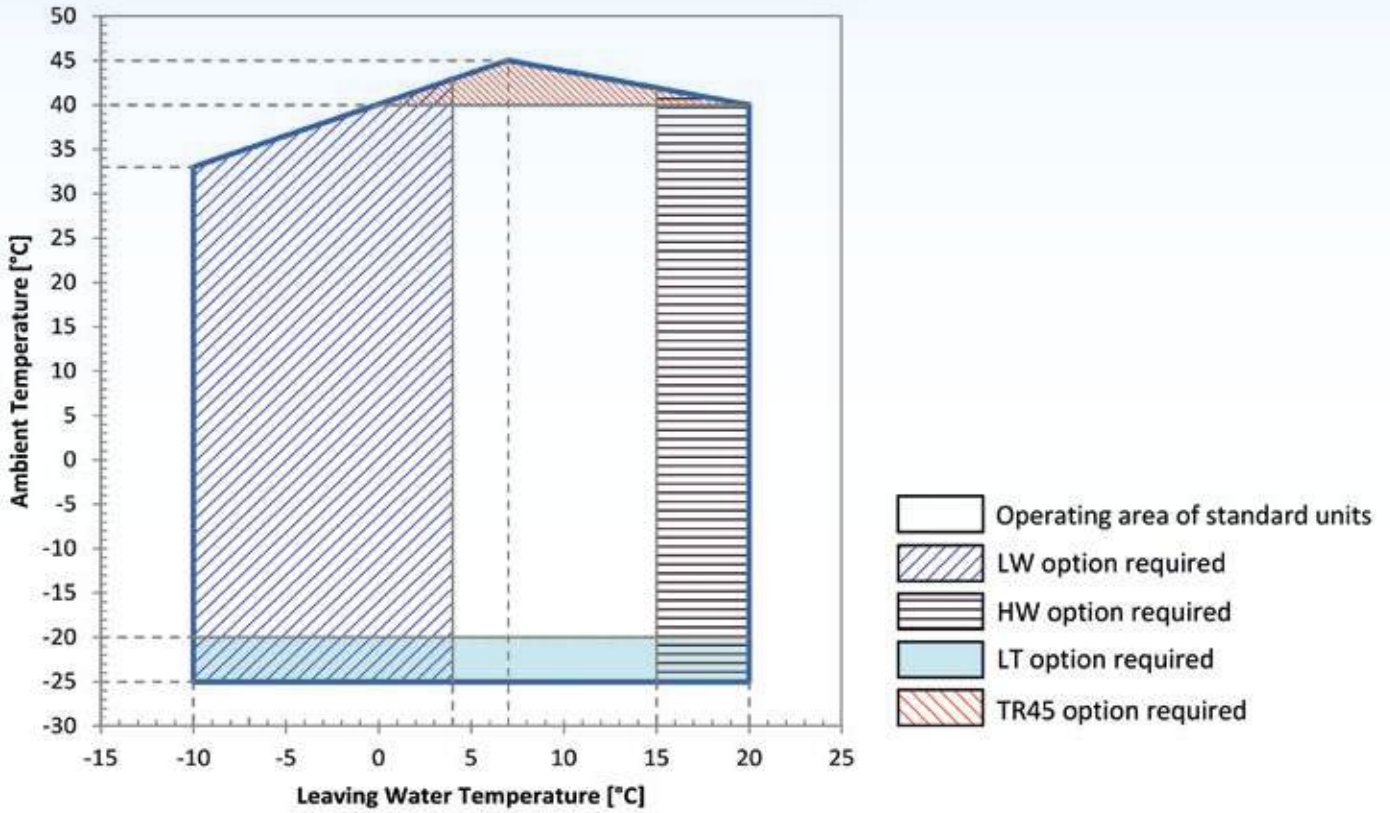

ENR models 340, 370

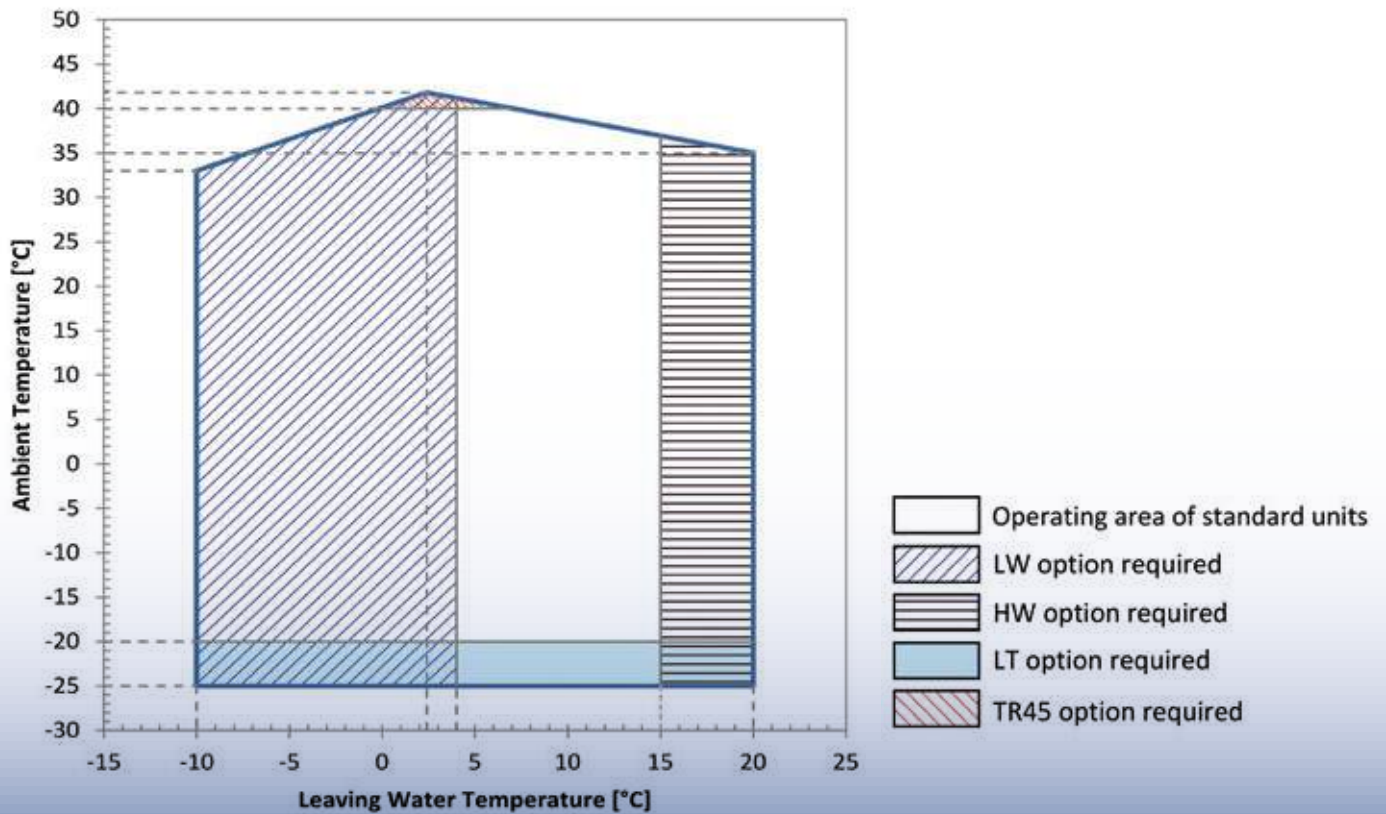

ENR models 430

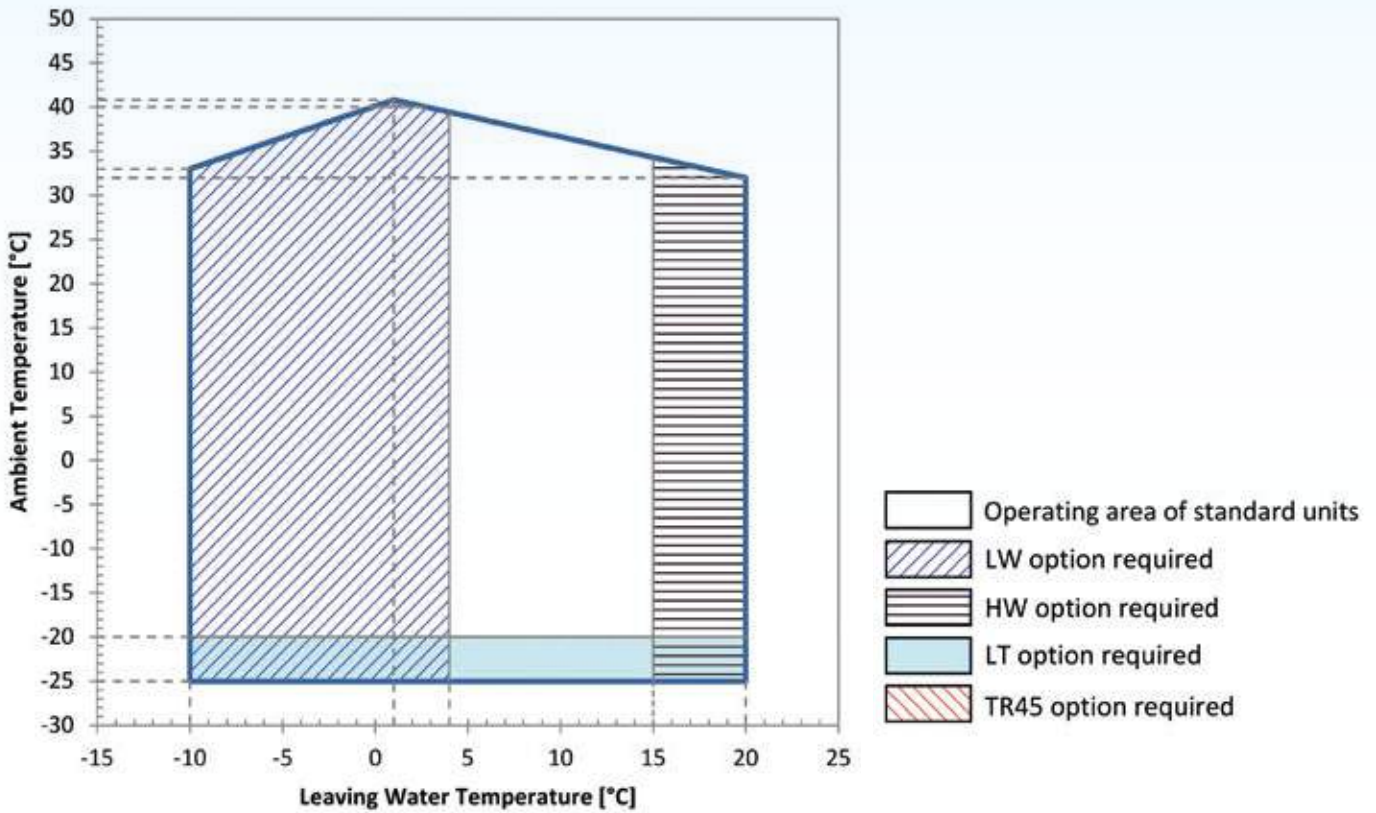

ENRF models 022, 030, 038, 045, 055, 061, 070, 075, 090, 100, 130, 160

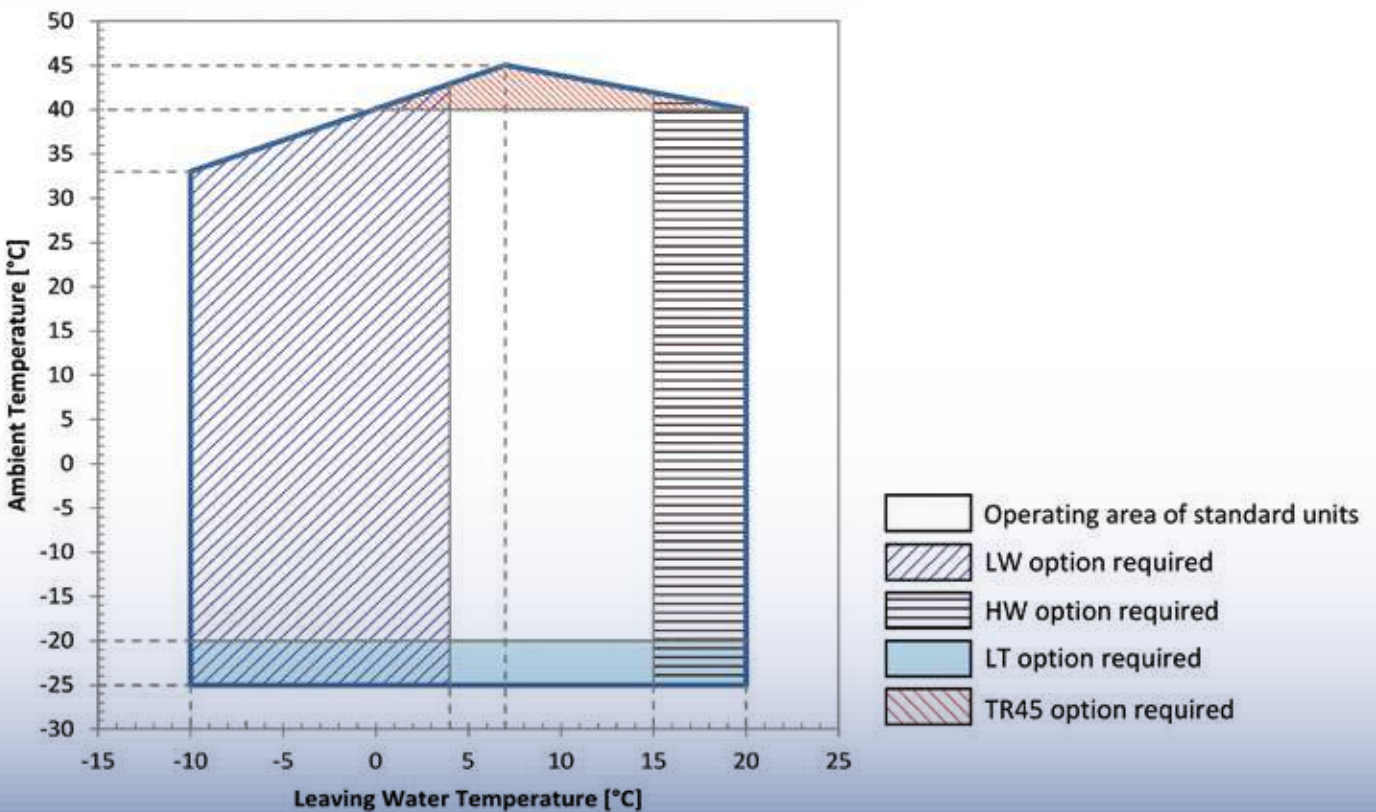

ENRF models 185, 200, 230

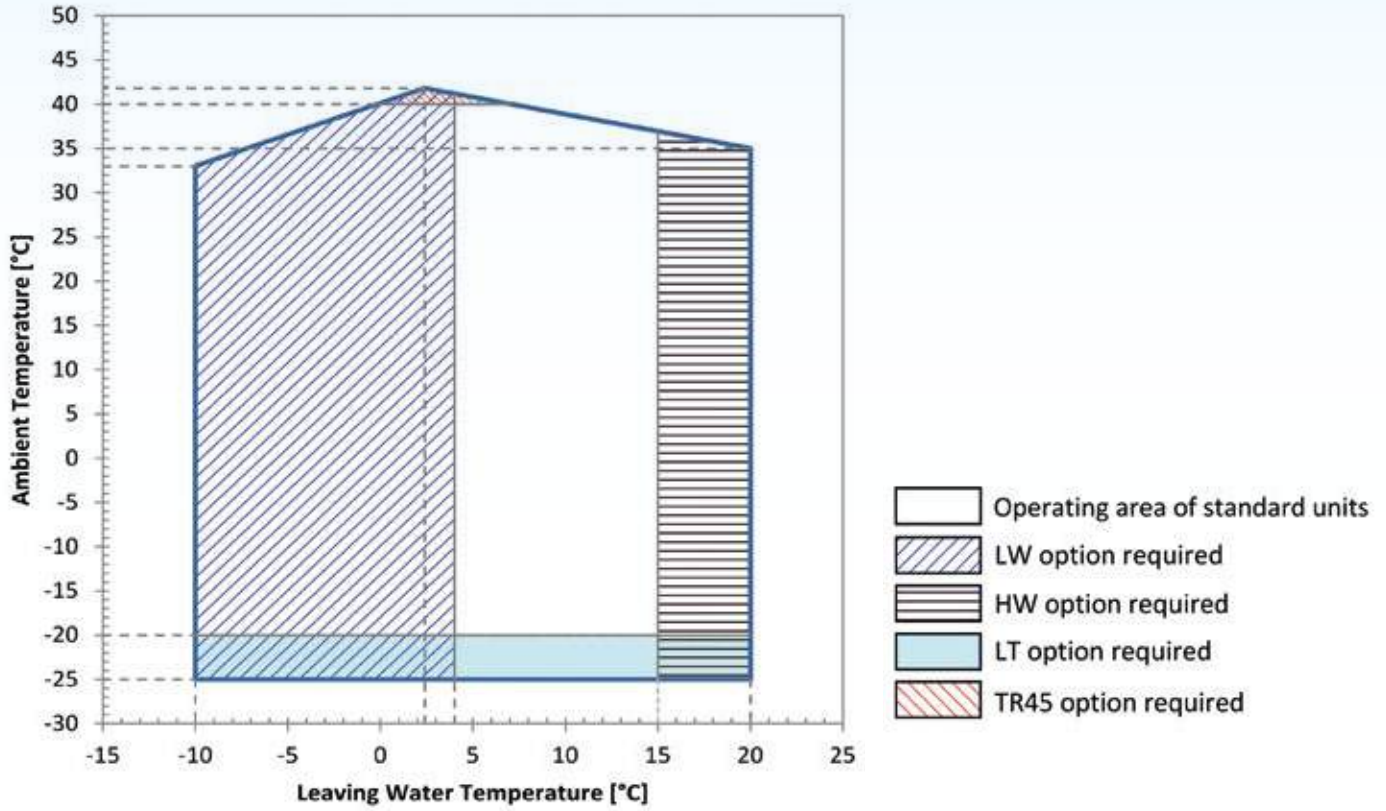

ENRF models 280, 340, 370

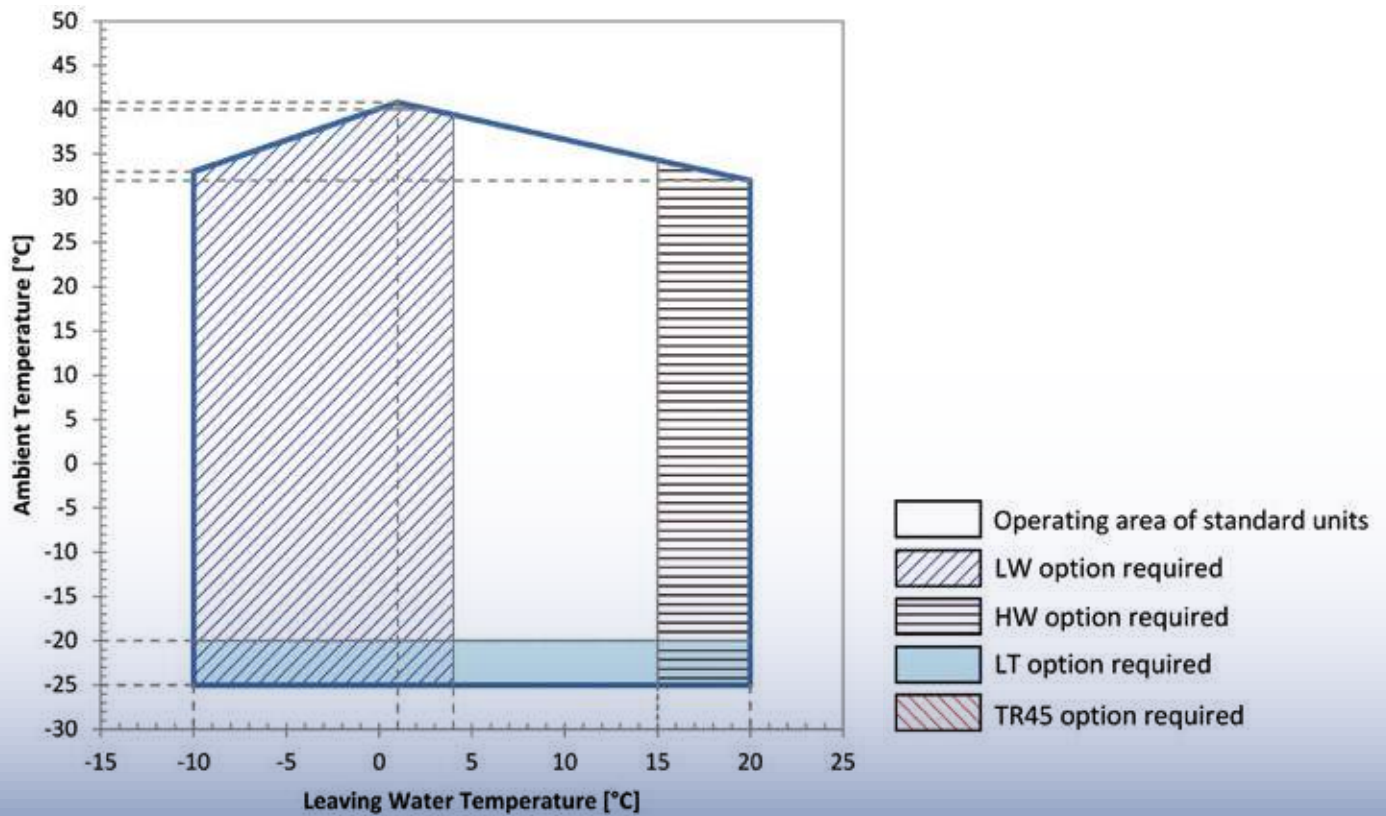

CSE models 030, 038, 045, 061, 075, 100

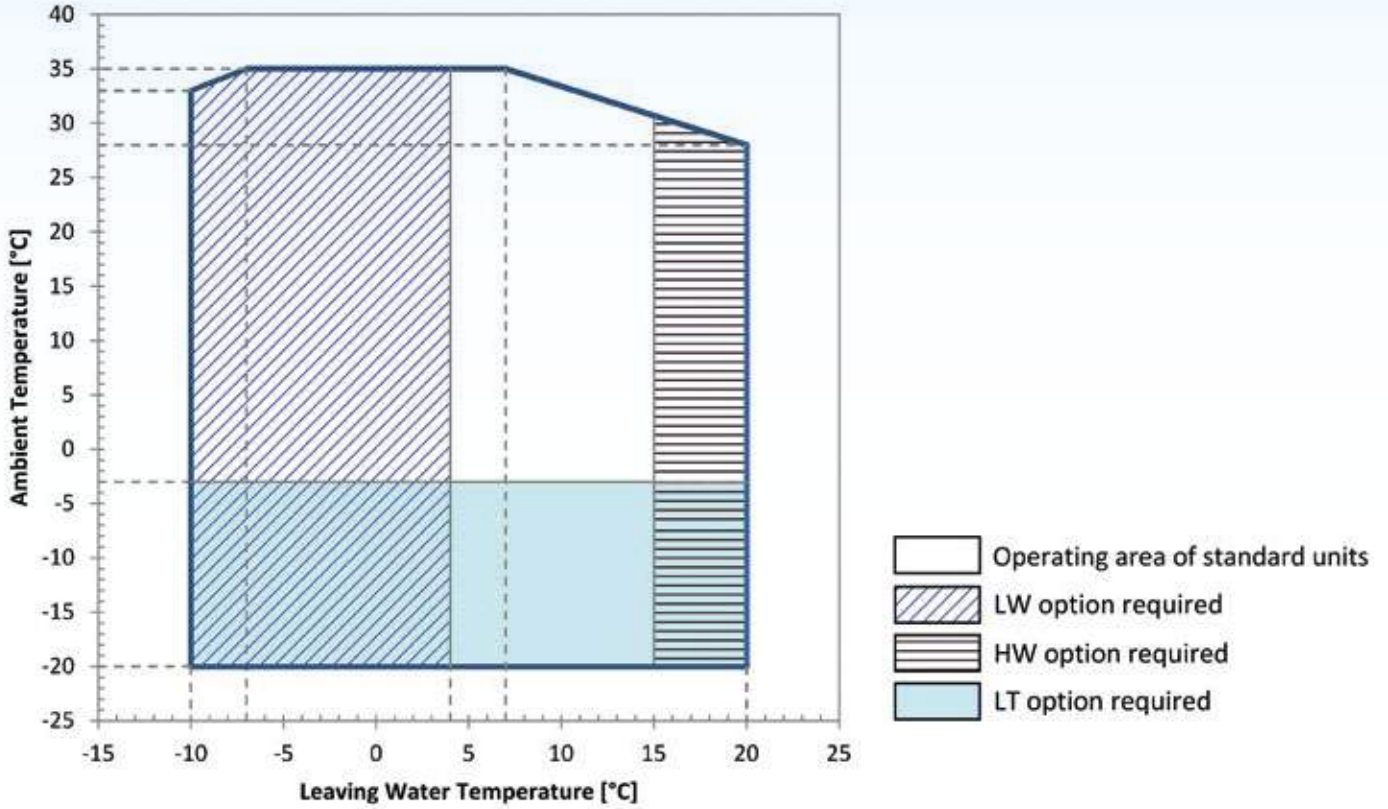

CSE models 130, 160, 185, 230, 280, 340, 370

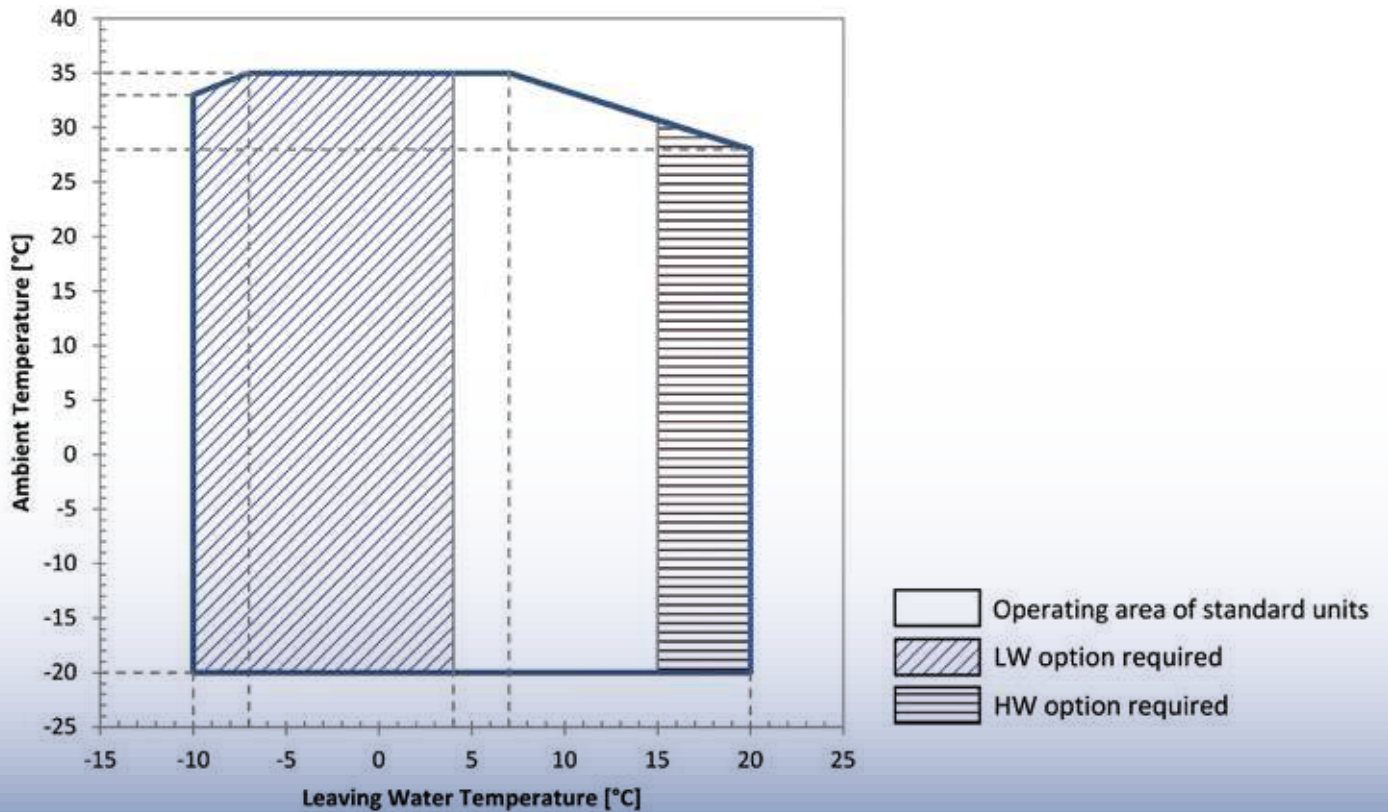

All the chillers need to operate with water flow rate internal of the range specified for each chiller at Chapter 16 "Technical Data".

If leaving water temperature is lower than 5°C it is necessary to use antifreeze solution, it is suggested to use antifreeze solution with freezing temperature at least 10K lower than the leaving water temperature.

It is necessary to use antifreeze solution also in case of ambient temperature lower than 0°C.

Freezing temperatures for mixtures of water and ethylene or propylene glycol as follows:

Alle Kühler müssen bei einer Wasserdurchflussrate innerhalb des Bereichs, der für jeden Kühler im Kapitel 16 "Technische Daten" angegeben ist, laufen.

Wenn die Auslasswassertemperatur unter 5°C fällt, muss ein Gefrierschutzmittel verwendet werden. Es wird empfohlen, Gefrierschutzmittel mit einem Gefrierpunkt zu verwenden, der mindestens 10 K unter der Wasserauslasstemperatur liegt.

Es muss auch ein Gefrierschutzmittel bei Umgebungstemperaturen unter 0°C verwendet werden.

Die Gefrierpunkte der Ethylen- oder Propylglycol-Wasser-Mischungen sind:

Freezing Point [°C] Gefrierpunkt [°C]	Ethylene Glycol [% by weight] Ethylenglycol [% Gewichtsanteil]	Propylene Glycol [% by weight] Propylenglycol [% Gewichtsanteil]
-5	12	16
-10	22	26
-15	30	34
-20	36	40
-25	40	44
-30	44	48
-35	48	52
-40	52	56

Available pressure for water pumps and evaporator pressure drops.

The following graphs shows the pump head pressure curve

Verfügbarer Druck für Wasserpumpen und Druckverlust am Verdampfer

Die folgenden Grafiken zeigen die Förderhöhe der Pumpe

pump P3 for **ENR models 001÷055** and **CSE models 030÷045**

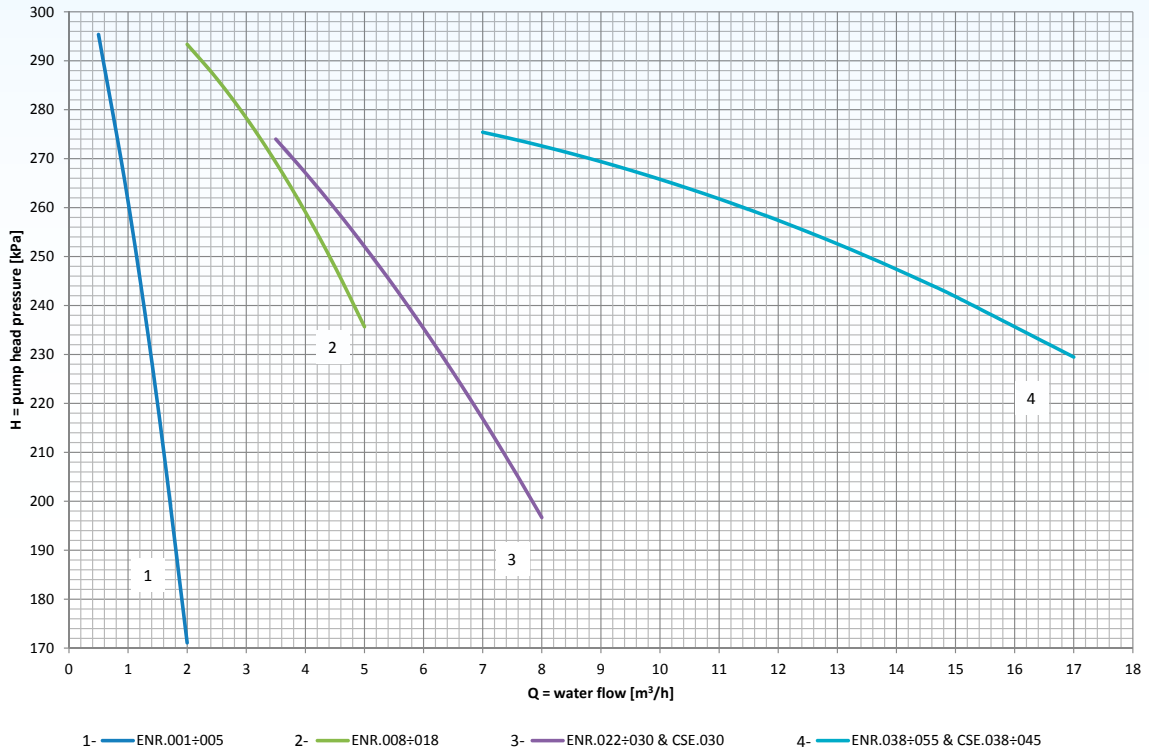

pump P3 for **ENR models 061÷480** and **CSE models 061÷370**

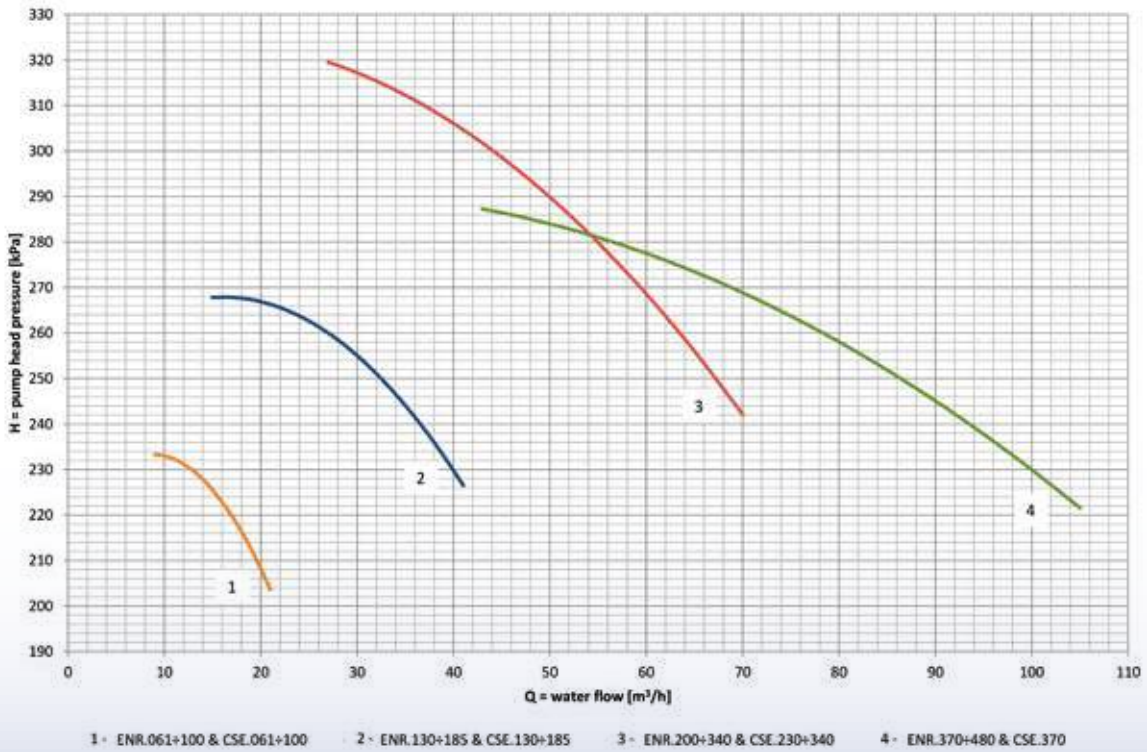

pump P3 for **ENRF models 022÷370**

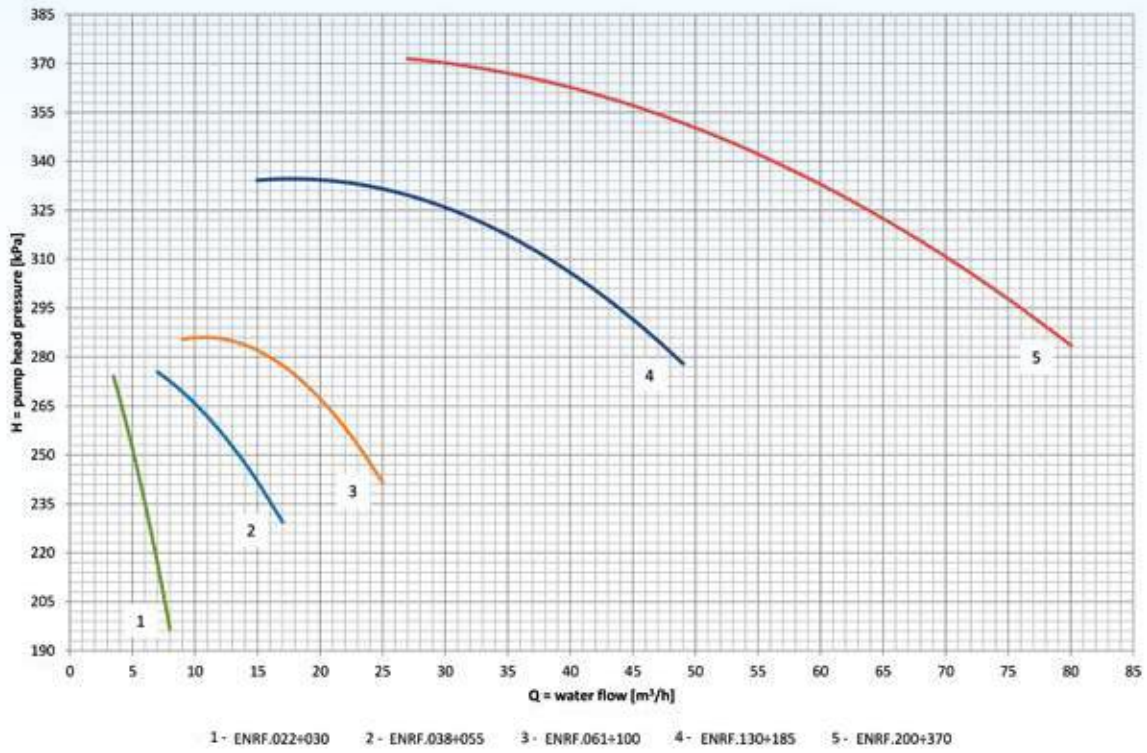

pump P5 for **ENR models 001÷055** and **CSE models 030÷045**

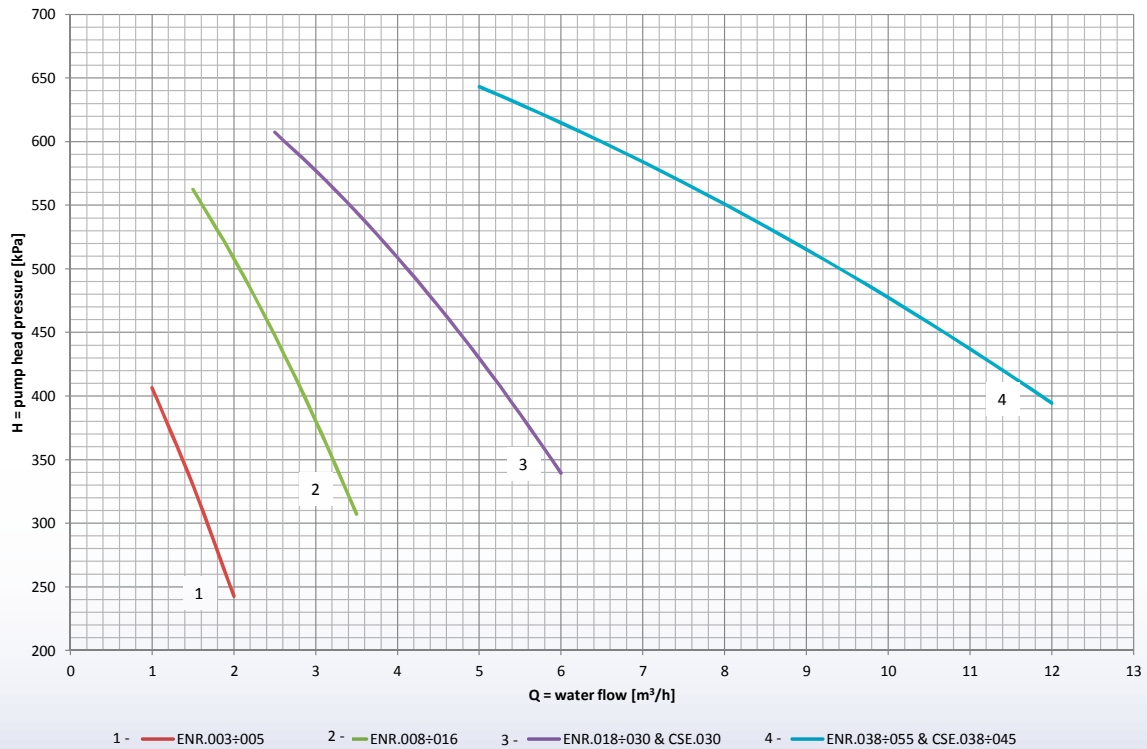

pump P5 for **ENR models 061÷480** and **CSE models 061÷370**

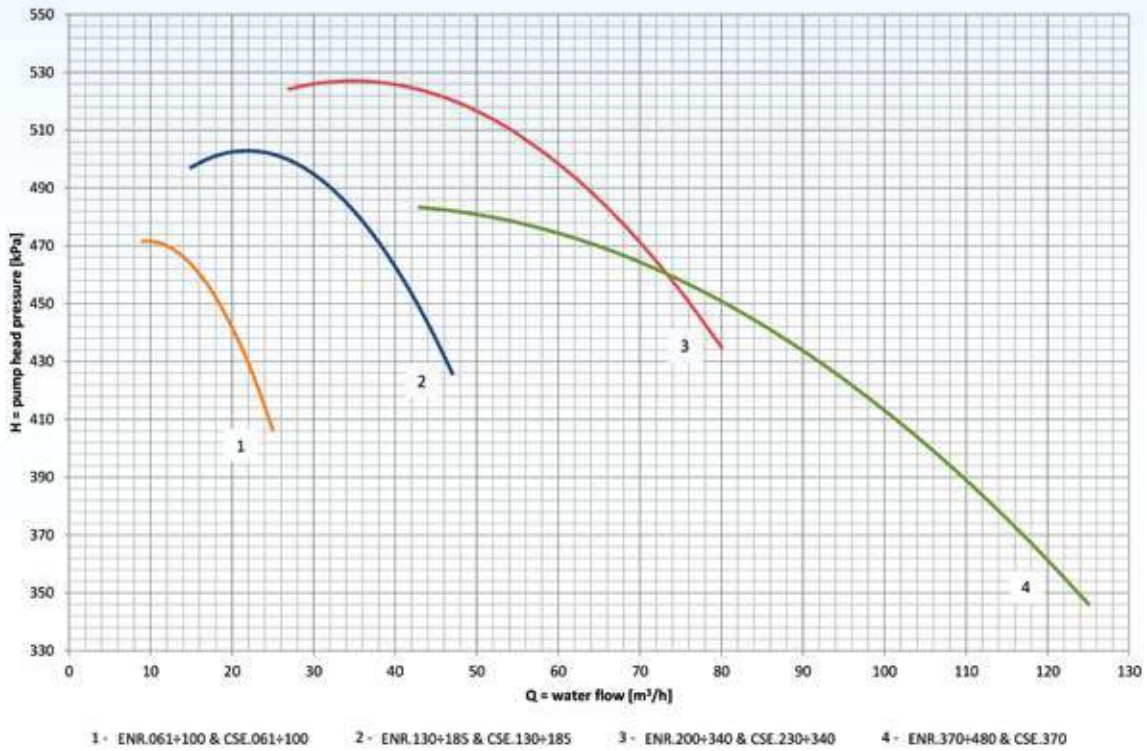

pump P5 for **ENRF models 022÷370**

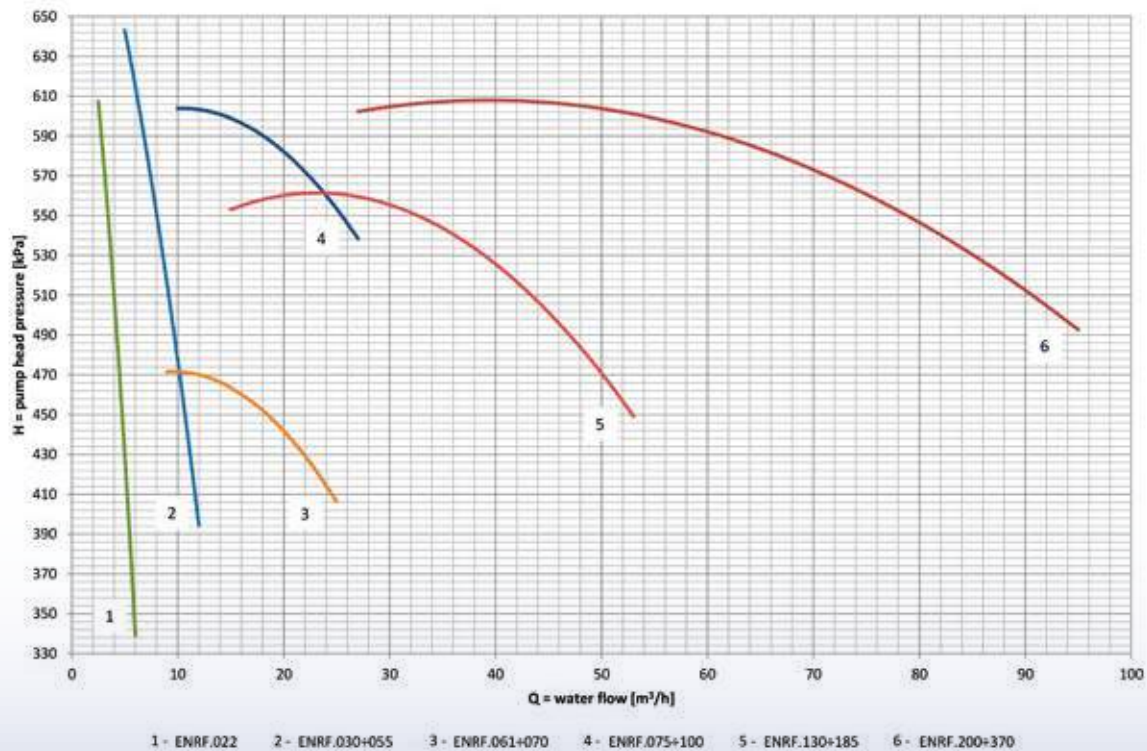

The table below summarizes the flow rate and the pressure drop for the series **ENR**, **ENRF** and **CSE**:

Die nachstehende Tabelle zeigt die Durchflussrate und den Druckabfall für die Serie **ENR**, **ENRF** und **CSE**:

Model	ENR	001	002	003	004	005	008	010	012	016	018	
NOMINAL WATER FLOW , Qn	m ³ /h	0,3	0,4	0,6	0,7	0,9	1,4	1,8	2,1	2,7	3,1	
WATER FLOW RANGE	m ³ /h	0,3 ÷ 2	0,3 ÷ 2	0,6 ÷ 2,2	0,6 ÷ 2,2	0,8 ÷ 2,2	1,2 ÷ 2,4	1,4 ÷ 3	1,2 ÷ 2,9	1,2 ÷ 2,9	2,5 ÷ 5	
TYPE OF EVAPORATOR	type	Plate evaporator			Coaxial evaporator							
CHILLER PRESSURE DROP WITH SINGLE PUMP , ΔPn	kPa	20	22	22	23	23	26	25	27	28	28	
CHILLER PRESSURE DROP WITH DOUBLE PUMP , ΔPn _{DP}	kPa	N.A.	N.A.	N.A.	N.A.	N.A.	N.A.	N.A.	N.A.	N.A.	35	

Model	ENR	022	030	038	045	055	061	070	075	090	100
NOMINAL WATER FLOW , Qn	m ³ /h	3,9	5,3	6,4	7,7	9,5	10,5	11,5	12,4	15,1	17,2
WATER FLOW RANGE	m ³ /h	3 ÷ 6	4 ÷ 6	6 ÷ 12	6 ÷ 12	6 ÷ 12	8 ÷ 18	10 ÷ 20	10 ÷ 20	10 ÷ 20	10 ÷ 20
TYPE OF EVAPORATOR	type	Coaxial evaporator									
CHILLER PRESSURE DROP WITH SINGLE PUMP , ΔPn	kPa	31	34	34	39	51	23	20	20	28	39
CHILLER PRESSURE DROP WITH DOUBLE PUMP , ΔPn _{DP}	kPa	42	55	42	51	69	36	35	38	37	50

Model	ENR	130	160	185	200	230	280	340	370	430	480
NOMINAL WATER FLOW , Qn	m ³ /h	19,8	25,8	29,2	35,1	39,0	47,6	54,9	62,8	70,5	75,7
WATER FLOW RANGE	m ³ /h	14 ÷ 27	15,4 ÷ 31	17,5 ÷ 35	25 ÷ 46	25 ÷ 46	31 ÷ 58	38 ÷ 70	45 ÷ 80	52 ÷ 100	54 ÷ 100
TYPE OF EVAPORATOR	type	Shell and tube evaporator									
CHILLER PRESSURE DROP WITH SINGLE PUMP , ΔPn	kPa	54	54	55	48	56	56	48	55	61	59
CHILLER PRESSURE DROP WITH DOUBLE PUMP , ΔPn _{DP}	kPa	69	63	66	52	64	68	65	76	71	70

Model	ENRF	022	030	038	045	055	061	070	075	090	100
NOMINAL WATER FLOW , Qn	m ³ /h	4,0	5,1	6,7	7,7	10,0	10,3	12,0	12,9	15,0	17,5
WATER FLOW RANGE	m ³ /h	3,2 ÷ 6	4 ÷ 8	6 ÷ 12	6 ÷ 12	6 ÷ 12	8,6 ÷ 19	10 ÷ 22	10 ÷ 22	10 ÷ 22	11,5 ÷ 23
TYPE OF EVAPORATOR	type	Coaxial evaporator									
CHILLER PRESSURE DROP WITH SINGLE PUMP , ΔPn	kPa	75	76	74	82	107	58	63	60	85	112
CHILLER PRESSURE DROP WITH DOUBLE PUMP , ΔPn _{DP}	kPa	87	95	83	94	127	70	80	79	94	124

Model	ENRF	130	160	185	200	230	280	340	370		
NOMINAL WATER FLOW , Qn	m ³ /h	20,3	25,8	29,9	34,4	38,9	47,5	55,9	61,1		
WATER FLOW RANGE	m ³ /h	14 ÷ 27	17,6 ÷ 31	26 ÷ 35	26 ÷ 46	26 ÷ 46	31 ÷ 58	38 ÷ 72	42 ÷ 80		
TYPE OF EVAPORATOR	type	Shell and tube evaporator									
CHILLER PRESSURE DROP WITH SINGLE PUMP , ΔPn	kPa	121	120	128	102	98	120	117	122		
CHILLER PRESSURE DROP WITH DOUBLE PUMP , ΔPn _{DP}	kPa	136	129	139	113	106	132	134	142		

Model	CSE	030	038	045	061	075	100	130	160	185	230	
NOMINAL WATER FLOW , Qn	m ³ /h	5,2	6,7	7,7	10,4	12,7	17,6	20,8	26,1	29,4	40,8	
WATER FLOW RANGE	m ³ /h	4 ÷ 6	6 ÷ 12	6 ÷ 12	8 ÷ 18	10 ÷ 20	10 ÷ 20	14 ÷ 27	15,4 ÷ 31	17,5 ÷ 35	25 ÷ 46	
TYPE OF EVAPORATOR	type	Coaxial evaporator					Shell and tube evaporator					
CHILLER PRESSURE DROP WITH SINGLE PUMP , ΔPn	kPa	54	53	56	52	55	54	67	66	62	68	
CHILLER PRESSURE DROP WITH DOUBLE PUMP , ΔPn _{DP}	kPa	72	66	67	64	75	67	89	76	74	90	

Model	CSE	280	340	370							
NOMINAL WATER FLOW , Qn	m ³ /h	49,9	58,0	64,8							
WATER FLOW RANGE	m ³ /h	31 ÷ 58	38 ÷ 70	45 ÷ 80							
TYPE OF EVAPORATOR	type	Shell and tube evaporator									
CHILLER PRESSURE DROP WITH SINGLE PUMP , ΔPn	kPa	67	59	63							
CHILLER PRESSURE DROP WITH DOUBLE PUMP , ΔPn _{DP}	kPa	116	104	106							

The available head pressure is calculated by the following expression:

Der verfügbare Druck wird durch die folgende Gleichung berechnet:

In case of single pump:

Bei Einzelpumpe

$$P = H - \left[\Delta P_n \cdot \left(\frac{Q}{Q_n} \right)^2 \right] \cdot C_g$$

In case of double pump:

Bei Doppelpumpe

$$P_{DP} = H - \left[\Delta P_{n,DP} \cdot \left(\frac{Q}{Q_n} \right)^2 \right] \cdot C_g$$

Where:

Woher:

- P [kPa], is the available head pressure with single pump;
- P_{DP} [kPa], is the available head pressure with double pump;
- H [kPa], is the pump head pressure from the above graphs;
- ΔP_n [kPa], is the nominal chiller pressure drop with single pump from the above table;
- ΔP_{n,DP} [kPa], is the nominal chiller pressure drop with double pump from the above table;
- Q [m³/h], is the volumetric water flow for the chiller working point;
- Q_n [m³/h], is the volumetric water flow for the nominal working point of chiller from the above table;
- C_g, is a coefficient that consider the increment of pressure drop due to the presence of glycol in mixture with water. C_g values from the table below.

- P [kPa], ist der verfügbare Druck mit Einzelpumpe;
- P_{DP} [kPa], ist der verfügbare Druck mit Doppelpumpe;
- H [kPa], Ist die Förderhöhe aus den obigen Graphen
- ΔP_n [kPa], ist der Nenndruckabfall des Kaltwassersatzes mit einzelner Pumpe aus der vorherigen Tabelle;
- ΔP_{n,DP} [kPa], ist der Nenndruckabfall des Kaltwassersatzes mit Doppelpumpe aus der vorherigen Tabelle;
- Q [m³/h], ist der Durchfluss im Arbeitsbereich des Kaltwassersatzes
- Q_n [m³/h] ist der Durchfluss des nominalen Arbeitsbereiches des Kaltwassersatzes aus der vorherigen Tabelle;
- C_g, ist der Koeffizient bei einer Mischung von Wasser mit Glykol. CG-Werte entnehmen Sie der folgenden Tabelle.

Glycol [% by weight] Glycol [% Gewichtsanteil]	0	20%	30%	40%	50%
Cg in case of Ethylene Glycol Cg im Falle von Ethylenglycol	1,000	1,091	1,182	1,242	1,333
Cg in case of Propylene Glycol Cg im Falle von Propylenglycol	1,000	1,182	1,273	1,394	1,515

17 Table Standard/Optional/Not Available

PROCESS COOLING APPLICATION **ENR**

STD = STANDARD
 OPT = OPTIONAL
 NA = NOT AVAILABLE

abbreviation	description	note \ model
PL	Private label	
1.0 MECHANICAL CONFIGURATION		
AM - ANTIVIBRANT MOUNTING		
ATS	spring type antivibrant mounting	AM variant
ATV	rubber type antivibrant mounting	AM variant
CC	copper tubes and copper fins condenser	
CF	condenser filter	NA with GPC
CG	condenser treatment (ElectroFin)	NA with CV
CV	epoxy coated condenser coil	NA with CG
FRAME COLOUR		
-	standard color RAL 7035	
CRAL	costumized color	
GALV	galvanized version (main frame and panels)	
GPC	condenser metallic grid protection	NA with CF
IFG	internal fan guard	
LNJ	low noise version	include: compr. Jackets, RV.
SSF	Stainless steel frame	
PAN	panel to separate refrigerating and electrical section from hydraulic and condenser section	
WHE	wheels (kit)	
2.0 HYDRIC CIRCUIT CONFIGURATION		
B1	evaporator inlet water temperature sensor (work probe)	
B2	evaporator outlet water temperature sensor (antifreeze probe)	
BP	internal by-pass	
BPA	automatic by-pass	BPA kit
VBA	automatic by-pass valve	BPA kit
CIRCUT CONFIGURATION		
OWC	open circuit configuration	CIRCUIT CONFIGURATION variant
CWC	closed circuit configuration	CIRCUIT CONFIGURATION variant
VSW	water safety relief valve	CWC kit
ASFA	automatic air vent	XV kit, replaces SFA, NA with OWC
RA	automatic feeder with check valve and filter incorporated	XV kit, NA with OWC
XV	expansion vessel	XV kit, NA with OWC
FL	flow switch	
MP - PROCESS PUMP		
WP	single pump P3	MP variant
DP	double pump P3	MP variant
NT.DP	no tank double pump P3	MP variant
PH	single pump P5	MP variant
DPH	double pump P5	MP variant
NT.DPH	no tank double pump P5	MP variant
GL50	special pump for glycol concentration from 30% to 50%	available only with WP or PH
GL50D	special double pump for glycol concentration from 30% to 50%	available only with DP or DPH
VRAP	double pump check valve	DP and DPH kit
VTPD	double pump ball valve	DP and DPH kit
MW	water pressure gauge	OPT with NP
RAGE	evaporator antifreeze heater	
RAGP	pump antifreeze heater	available only with WP or PH
RAGDP	pump antifreeze heater	available only with DP or DPH
RAGT	tank antifreeze heater	NA with NT
SCA - WATER HEAT EXCHANGER (EVAPORATOR)		
CX	self-cleaning coaxial evaporator	SCA variant
B-ES	brased plate evaporator	SCA variant
ST	shell and tube evaporator	SCA variant
SFA	manual air vent	
T - TANK		
NT	no tank	T variant
NT.NP	no tank no pump	T variant
CST	tank in carbon steel	T variant
CST.NP	tank in carbon steel no pump	T variant, NA with OWC
SST	tank in stainless steel	T variant
SST.NP	tank in stainless steel no pump	T variant, NA with OWC
SST.B-ES	tank in stainless steel with plate evaporator	T variant
LLA	electric float low water level alarm	NA with NT
RM	manual filling cap	NA with NT
SFAS	tank manual air vent	NA with NT
VSCS	tank water drain valve	NA with NT
VSWS	tank safety relief valve	NA with OWC or NT
VSC	water drain valve	
VTP	ball valve between tank and pump	NA with NP
WATER CONNECTIONS		

PROCESS COOLING APPLICATION **ENR**

STD = STANDARD
 OPT = OPTIONAL
 NA = NOT AVAILABLE

abbreviation	description	note \ model
-	flanged	
-	threaded	

3.0 REFRIGERANT CIRCUIT CONFIGURATION

CP	capillary tube	
CSV	compressors shut off valve	
DRV	dual safety relief valve	DRV kit
RSAP	VSAP changeover valve	DRV kit
RSBP	VSBP changeover valve	DRV kit
EXPANSION VALVE		
VTS	thermostatic expansion valve	EXPANSION VALVE variant
ETS	electronic expansion valve	ETS kit, EXPANSION VALVE variant
B11, B12	compressor suction temperature sensor for the electronic exp. valve	ETS kit
B13, B14	low pressure trasducer for the electronic expansion valve	ETS kit
FLT	dehydrating filter	
HP	high pressure switch	
HPG	high pressure gauge	
HW	leaving water temperature between 15°C to 20degC	
LIQ	sight glass	
LP	low pressure switch	
LPG	low pressure gauge	
LT	low ambient temperature until -25°C (-20°C until model ENR.022)	include: RC, RV, EB.
LW	low water temperature until -10°C outlet (-8°C until model ENR.022)	include: RC, RV, thicker insulation.
MC - COMPRESSOR		
-	rotary	
-	scroll	
OIL	sight glass for equalisation line of oil	
RC	compressor crankcase heater	
NUMBER OF REFRIGERANT CIRCUITS		
-	single refrigerant circuit	
DC	double refrigerant circuit	NA with ST until model ENR.100
PDS	partial desuperheater	
PMC	hot gas bypass	PMC kit, include µC2SE (008-022)
RGC	hot gas shut off valve	PMC kit
Y19, Y20	hot gas bypass valve (solenoid valve)	PMC kit
SCE	air heat exchanger (condenser)	
SCR	charge valve (schrader)	
VSAP	high pressure safety relief valve	
VSBP	low pressure safety relief valve	
Y4, Y8	liquid line solenoid valve	

4.0 ELECTRIC CIRCUIT CONFIGURATION

CONTROLLER		
XR30CX	thermostat XR30CX Dixell (230V)	
µC2SE	microchiller 2SE base board (24V)	NA with XR30CX
EB	control box heater	
EL	air/liquid heat exchanger for the control box cooling	NA with EV
ELECTRICAL FEED		
-	230V/1ph/50Hz	
-	400V/3ph/50Hz with neutral	
SN	400V/3ph/50Hz without neutral	
EV	forced ventilation of the control box	NA with EL
HRM	Hours run meter	
MC - COMPRESSOR		
IRC	inverter for compressors	include: DC, iCHILL
SF	soft start	
MP - PROCESS PUMP		
AT	automatic management pumps	DP and DPH kit
IRP	inverter pump speed regulation	available only with WP
IRD	inverter pump speed regulation	available only with DP
IRPH	inverter pump speed regulation	available only with PH
IRDPH	inverter pump speed regulation	available only with DPH
MV - AXIAL FAN MOTOR		
-	AC fans	MV variant
EC	EC fans	MV variant
ECH	EC fans with high head pressure	MV variant
PV	fans pressure switch	NA with EC
RV	electronic fan speed control	RV kit, replaces PV, NA with EC
CPRV	capillary tube for the RV	RV kit, NA with EC
B5÷6	high pressure trasducer	RV or EC kit
OFC	on-off compressors signal	
OFR	remote control (on/off)	NA with OFRC

PROCESS COOLING APPLICATION **ENR**

STD = STANDARD
 OPT = OPTIONAL
 NA = NOT AVAILABLE

abbreviation	description	note \ model
OFRC	remote control display with on/off remote+alarm management	NA with OFR, include mC2SE (008-022)
PD	display cover protection	
PFC	power Factor Correction, cos(phi) > 0,95	
PROTECTION RATING	protection rating IP54	
Q0	general switch of the chiller	
RS485	serial card for modbus RS485	NA with OFRC
RVG	volt-metric relay (phase sequence relay CSF included)	
TROPICALIZED VERSION		
-	max ambient temperature until 40°C	
TR45	max ambient temperature until 45°C	include: EV, el comp. for amb. 45°C.
TR50	max ambient temperature until 50°C	include: EV, el comp. for amb. 50°C, EC
GENERAL ALARM	voltage free-contact for general alarm	
VAL	acoustic and visual alarm	available with GENERAL ALARM
REMOTE ON/OFF	voltage-free contact for remote on/off	

5.0 PACKING

ANS	rubber pad antivibrating (shipment)	
NCC - STANDARD PACKING		
NCC0	full cardboard protection	
NCC1	full cardboard protection with wooden spacers on bottom	
NCC2	vertical cardboard protection on unit corners, nylon covering and wooden spacers on bottom	
PLT	pallet on bottom	
WC - WOODEN PROTECTION		
WCA	wooden cage	WC variant
WCR	wooden crate	WC variant

Doc. code: SCO-PCA-ENR
 Area: IPT-CS

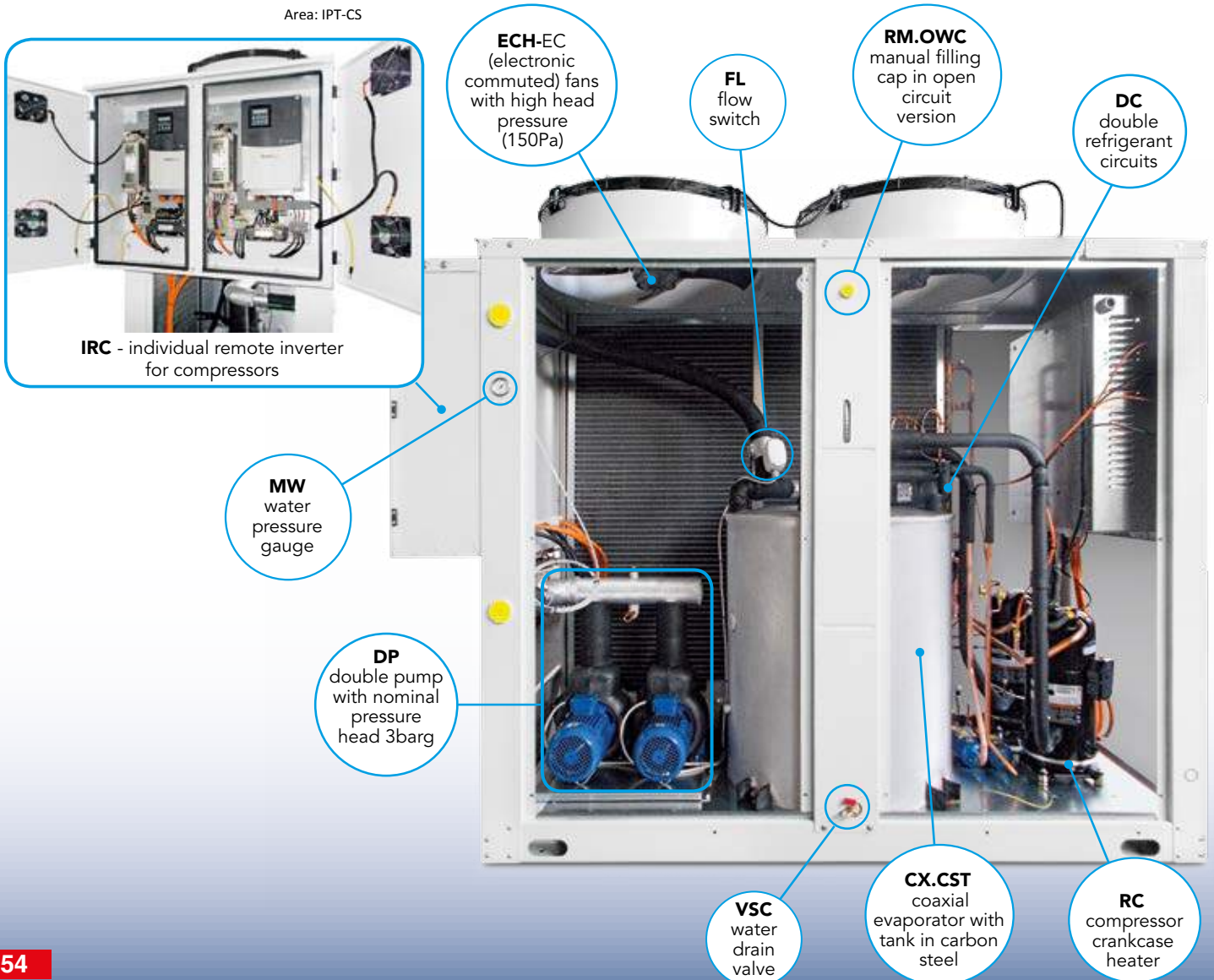

001	002	003	004	005	008	010	012	016	018	022	030	038	045	055	061	070	075	090	100	130	160	185	200	230	280	340	370	430	480
NA	NA	NA	NA	NA	OPT	OPT	OPT	OPT	OPT	OPT	OPT	OPT	OPT	OPT	OPT	OPT	OPT	OPT	OPT	OPT	OPT	OPT	OPT	OPT	OPT	OPT	OPT	OPT	OPT
NA	NA	NA	NA	NA	OPT	OPT	OPT	OPT	OPT	OPT	OPT	OPT	OPT	OPT	OPT	OPT	OPT	OPT	OPT	OPT	NA	NA	NA	NA	NA	NA	NA	NA	NA
NA	NA	NA	NA	NA	NA	NA	NA	NA	NA	NA	NA	NA	NA	NA	NA	NA	NA	NA	NA	NA	OPT	OPT	OPT	OPT	OPT	OPT	OPT	OPT	OPT
STD	STD	STD	STD	STD	STD	STD	STD	STD	STD	STD	STD	STD	STD	STD	STD	STD	STD	STD	STD	STD	STD	STD	STD	STD	STD	STD	STD	STD	STD
STD	STD	STD	STD	STD	STD	STD	STD	STD	STD	STD	STD	STD	STD	STD	STD	STD	STD	STD	STD	STD	STD	STD	STD	STD	STD	STD	STD	STD	STD
OPT	OPT	OPT	OPT	OPT	OPT	OPT	OPT	OPT	OPT	OPT	OPT	OPT	OPT	OPT	OPT	OPT	OPT	OPT	OPT	OPT	OPT	OPT	OPT	OPT	OPT	OPT	OPT	OPT	OPT
NA	NA	NA	NA	NA	OPT	OPT	OPT	OPT	OPT	OPT	OPT	OPT	OPT	OPT	OPT	OPT	OPT	OPT	OPT	OPT	OPT	OPT	OPT	STD	STD	STD	STD	STD	STD
STD	STD	STD	STD	STD	STD	STD	STD	STD	STD	STD	STD	STD	STD	STD	STD	STD	STD	STD	STD	STD	STD	STD	STD	STD	STD	STD	STD	STD	STD
NA	NA	NA	NA	NA	OPT	OPT	OPT	OPT	OPT	OPT	OPT	OPT	OPT	OPT	OPT	OPT	OPT	OPT	OPT	OPT	OPT	OPT	OPT	OPT	OPT	OPT	OPT	OPT	OPT
NA	NA	NA	NA	NA	NA	NA	NA	NA	NA	NA	NA	NA	NA	NA	NA	NA	NA	NA	NA	NA	NA	NA	NA	NA	NA	NA	NA	NA	NA
OPT	OPT	OPT	OPT	OPT	OPT	OPT	OPT	OPT	OPT	OPT	STD	STD	STD	STD	STD	STD	STD	STD	STD	STD	STD	STD	STD	STD	STD	STD	STD	STD	STD
NA	NA	NA	NA	NA	OPT	OPT	OPT	OPT	OPT	OPT	OPT	OPT	OPT	OPT	OPT	OPT	OPT	OPT	OPT	OPT	OPT	OPT	OPT	OPT	OPT	OPT	OPT	OPT	OPT
NA	NA	NA	NA	NA	STD	STD	STD	STD	STD	STD	STD	STD	STD	STD	STD	STD	STD	STD	STD	STD	STD	STD	STD	STD	STD	STD	STD	STD	STD

NA	NA	NA	NA	NA	NA	NA	NA	NA	NA	NA	NA	NA	NA	NA	NA	NA	NA	NA	NA	NA	OPT	OPT	OPT	OPT	OPT	OPT	OPT	OPT	OPT
NA	NA	STD	STD	STD	STD	STD	STD	STD	STD	STD	STD	STD	STD	STD	STD	STD	STD	STD	STD	STD	STD	STD	STD	STD	STD	STD	STD	STD	STD
STD	STD	NA	NA	NA	NA	NA	NA	NA	NA	NA	NA	NA	NA	NA	NA	NA	NA	NA	NA	NA	NA	NA	NA	NA	NA	NA	NA	NA	
NA	NA	NA	NA	NA	NA	NA	NA	NA	NA	NA	NA	NA	NA	NA	STD	STD	STD	STD	STD	STD	STD	STD	STD	STD	STD	STD	STD	STD	STD
OPT	OPT	OPT	OPT	OPT	OPT	OPT	OPT	OPT	OPT	OPT	NA	NA	NA	NA	NA	NA	NA	NA	NA	NA	NA	NA	NA	NA	NA	NA	NA	NA	
OPT	OPT	OPT	OPT	OPT	OPT	OPT	OPT	OPT	OPT	OPT	OPT	OPT	OPT	OPT	OPT	OPT	OPT	OPT	OPT	OPT	OPT	OPT	OPT	OPT	OPT	OPT	OPT	OPT	OPT
OPT	OPT	OPT	OPT	OPT	OPT	OPT	OPT	OPT	OPT	OPT	OPT	OPT	OPT	OPT	OPT	OPT	OPT	OPT	OPT	OPT	OPT	OPT	OPT	OPT	OPT	OPT	OPT	OPT	OPT

Updated on: 18/07/2017
Revision number: 6

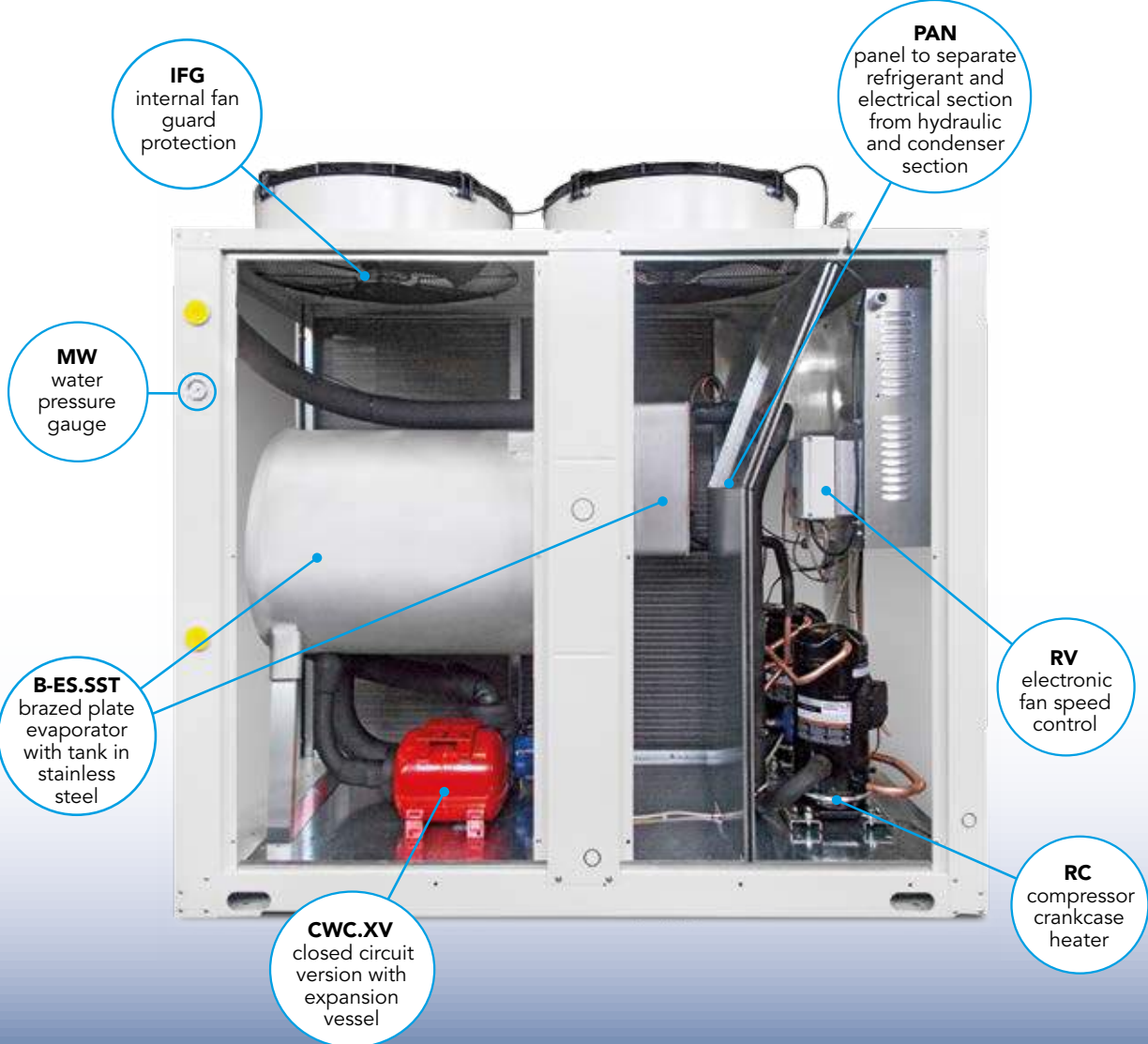

PROCESS COOLING APPLICATION **ENRF**

STD = STANDARD
 OPT = OPTIONAL
 NA = NOT AVAILABLE

abbreviation	description	note \ model
PL	Private label	
1.0 MECHANICAL CONFIGURATION		
AM - ANTIVIBRANT MOUNTING		
ATS	spring type antivibrant mounting	AM variant
ATV	rubber type antivibrant mounting	AM variant
CC	copper tubes and copper fins condenser	
CF	condenser filter	NA with GPC
CG	condenser treatment (ElectroFin)	NA with CV
CV	epoxy coated condenser coil	NA with CG
FRAME COLOUR		
-	standard color RAL 7035	
CRAL	customized color	
GALV	galvanized version (main frame and panels)	
GPC	condenser metallic grid protection	NA with CF
IFG	internal fan guard	
LNJ	low noise version	include: compr. Jackets, RV.
SSF	Stainless steel frame	
2.0 HYDRIC CIRCUIT CONFIGURATION		
B1	evaporator inlet water temperature sensor (work probe)	
B2	evaporator outlet water temperature sensor (antifreeze probe)	
BPA	automatic by-pass	BPA kit
VBA	automatic by-pass valve	BPA kit
CIRCUIT CONFIGURATION		
CWC	closed circuit configuration	
VSW	water safety relief valve	CWC kit
ASFA	automatic air vent	XV kit, replaces SFA
RA	automatic feeder with check valve and filter incorporated	XV kit
XV	expansion vessel	XV kit
FL	flow switch	
MP - PROCESS PUMP		
WP	single pump P3	MP variant
DP	double pump P3	MP variant
NT.DP	no tank double pump P3	MP variant
PH	single pump P5	MP variant
DPH	double pump P5	MP variant
NT.DPH	no tank double pump P5	MP variant
GL50	special pump for glycol concentration from 30% to 50%	available only with WP or PH
GL50D	special double pump for glycol concentration from 30% to 50%	available only with DP or DPH
VRAP	double pump check valve	DP and DPH kit
VTPD	double pump ball valve	DP and DPH kit
MW	water pressure gauge	OPT with NP
RAGE	evaporator antifreeze heater	
RAGP	pump antifreeze heater	available only with WP or PH
RAGDP	pump antifreeze heater	available only with DP or DPH
RAGT	tank antifreeze heater	NA with NT
SCA - WATER HEAT EXCHANGER (EVAPORATOR)		
CX	self-cleaning coaxial evaporator	SCA variant
B-ES	brased plate evaporator	SCA variant
ST	shell and tube evaporator	SCA variant
SFA	manual air vent	
SFC - AIR-WATER HEAT EXCHANGER (FREE COOLING)		
B3	free cooling inlet water temperature sensor	
B4	ambient temperature sensor	
SFAF	free cooling manual air vent	
VSCF	free cooling water drain valve	
Y15	FREE COOLING VALVE SERVOCONTROL	
-	2 ways valve	Y15 variant
-	3 ways valve	Y15 variant
Y16	evaporator 2 ways valve servocontrol	
T - TANK		
NT	no tank	T variant
NT.NP	no tank no pump	T variant
CST	tank in carbon steel	T variant
CST.NP	tank in carbon steel no pump	T variant
SST	tank in stainless steel	T variant
SST.NP	tank in stainless steel no pump	T variant
SST.B-ES	tank in stainless steel with plate evaporator	T variant
LLA	electric float low water level alarm	NA with NT
RM	manual filling cap	NA with NT
SFAS	tank manual air vent	NA with NT
VSCS	tank water drain valve	NA with NT

PROCESS COOLING APPLICATION **ENRF**

STD = STANDARD
 OPT = OPTIONAL
 NA = NOT AVAILABLE

abbreviation	description	note \ model
VSW	tank safety relief valve	NA with NT
VSC	water drain valve	
VTP	ball valve between tank and pump	NA with NP
WATER CONNECTIONS		
-	flanged	
-	threaded	

3.0 REFRIGERANT CIRCUIT CONFIGURATION

CSV	compressors shut off valve	
DRV	dual safety relief valve	DRV kit
RSAP	VSAP changeover valve	DRV kit
RSBP	VSBP changeover valve	DRV kit
EXPANSION VALVE		
VTS	thermostatic expansion valve	EXPANSION VALVE variant
ETS	electronic expansion valve	ETS kit, EXPANSION VALVE variant
B11, B12	compressor suction temperature sensorfor the electronic exp. valve	ETS kit
B13, B14	low pressure trasducer for the electronic expansion valve	ETS kit
FLT	dehydrating filter	
HP	high pressure switch	
HPG	high pressure gauge	
HW	leaving water temperature between15°C to 20degC	
LIQ	sight glass	
B7,B8	low pressure trasducer	
LPG	low pressure gauge	
LT	low ambient temperature until -25°C	include: RC, RV, EB.
LW	low water temperature until -10°C outlet	include: RC, RV, thicker insulation.
MC - COMPRESSOR		
-	scroll	
OIL	sight glass for equalisation line of oil	
RC	compressor crankcase heater	
NUMBER OF REFRIGERANT CIRCUITS		
-	single refrigerant circuit	
DC	double refrigerant circuit	NA with ST until model ENRF.100
PDS	partial desuperheater	
SCE	air heat exchanger (condenser)	
SCR	charge valve (schrader)	
VSAP	high pressure safety relief valve	
VSBP	low pressure safety relief valve	
Y4, Y8	liquid line solenoid valve	

4.0 ELECTRIC CIRCUIT CONFIGURATION

CONTROLLER	pCO5 control board (master, 24V)	
EB	contol box heater	
EL	air/liquid heat exchanger for the control box cooling	NA with EV
ELECTRICAL FEED	400V/3ph/50Hz without neutral	
EV	forced ventilation of the control box	NA with EL
HRM	Hours run meter	
MC - COMPRESSOR		
IRC	inverter for compressors	include: DC
SF	soft start	
MP - PROCESS PUMP		
AT	automatic management pumps	DP and DPH kit
IRP	inverter pump speed regulation	available only with WP
IRD	inverter pump speed regulation	available only with DP
IRPH	inverter pump speed regulation	available only with PH
IRDPH	inverter pump speed regulation	available only with DPH
MV - AXIAL FAN MOTOR		
-	AC fans	MV variant
EC	EC fans	MV variant
ECH	EC fans with high head pressure	MV variant
RV	electronic fan speed control	RV kit, NA with EC
B5÷6	high pressure trasducer	RV or EC kit
OFC	on-off compressors signal	
OFR	remote control (on/off)	NA with OFRC
OFRC	remote control display with on/off remote+alarm management	NA with OFR
PD	display cover protection	
PFC	power Factor Correction, cos(phi) > 0,95	
PROTECTION RATING	protection rating IP54	
Q0	general switch of the chiller	
RS485	serial card for modbus RS485	NA with OFRC
RVG	volt-metric relay (phase sequence relay CSF included)	
TROPICALIZED VERSION		
-	max ambient temperature until 40°C	

PROCESS COOLING APPLICATION **ENRF**

abbreviation	description	note \ model
TR45	max ambient temperature until 45°C	include: EV, el comp. for amb. 45°C.
TR50	max ambient temperature until 50°C	include: EV, el comp. for amb. 50°C, EC
GENERAL ALARM VAL	voltage free-contact for general alarm acustic and visual alarm	available with GENERAL ALARM
REMOTE ON/OFF	voltage-free contact for remote on/off	

5.0 PACKING

ANS	rubber pad antivibrating (shipment)	
NCC - STANDARD PACKING		
NCC1	full cardboard protection with wooden spacers on bottom	
NCC2	vertical cardboard protection on unit corners, nylon covering and wooden spacers on bottom	
WC - WOODEN PROTECTION		
WCA	wooden cage	WC variant
WCR	wooden crate	WC variant

Doc. code: SCO-PCA-ENRF
 Area: IPT-CS

STD = STANDARD
 OPT = OPTIONAL
 NA = NOT AVAILABLE

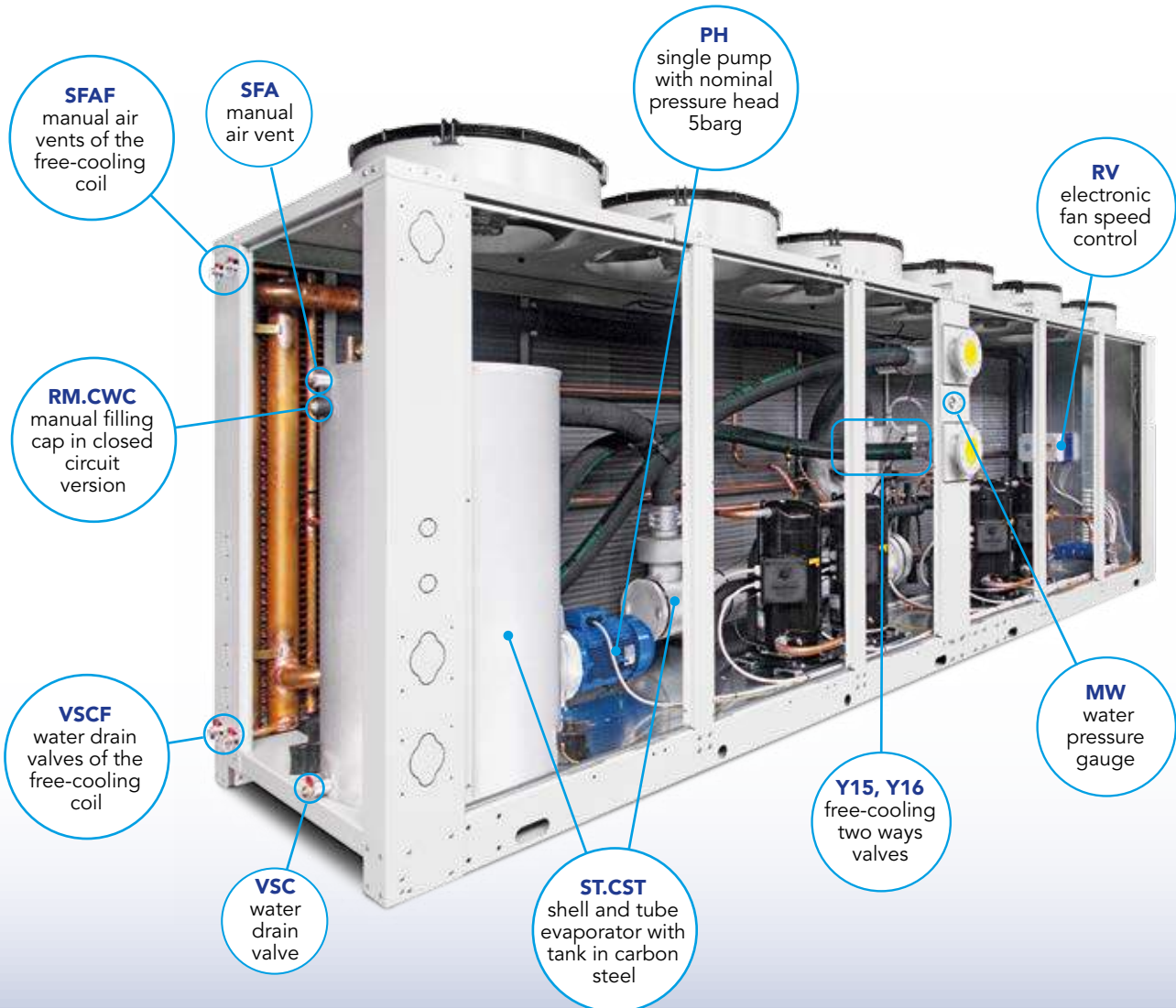

022	030	038	045	055	061	070	075	090	100	130	160	185	200	230	280	340	370
OPT	OPT	OPT	OPT	OPT	OPT	OPT	OPT	OPT	OPT	OPT	OPT	OPT	OPT	OPT	OPT	OPT	OPT
OPT	OPT	OPT	OPT	OPT	OPT	OPT	OPT	OPT	OPT	OPT	OPT	OPT	OPT	OPT	OPT	OPT	OPT
STD	STD	STD	STD	STD	STD	STD	STD	STD	STD	STD	STD	STD	STD	STD	STD	STD	STD
OPT	OPT	OPT	OPT	OPT	OPT	OPT	OPT	OPT	OPT	OPT	OPT	OPT	OPT	OPT	OPT	OPT	OPT
STD	STD	STD	STD	STD	STD	STD	STD	STD	STD	STD	STD	STD	STD	STD	STD	STD	STD

NA	NA	NA	NA	NA	OPT	OPT	OPT	OPT	OPT	OPT	OPT	OPT	OPT	OPT	OPT	OPT	OPT
STD	STD	NA	NA	NA	NA	NA	NA	NA	NA	NA	NA	NA	NA	NA	NA	NA	
NA	NA	STD	STD	STD	STD	STD	STD	STD	STD	STD	STD	STD	STD	STD	STD	STD	
OPT	OPT	OPT	OPT	OPT	OPT	OPT	OPT	OPT	OPT	OPT	OPT	OPT	OPT	OPT	OPT	OPT	
OPT	OPT	OPT	OPT	OPT	OPT	OPT	OPT	OPT	OPT	OPT	OPT	OPT	OPT	OPT	OPT	OPT	



PROCESS COOLING APPLICATION **CSE**

STD = STANDARD
 OPT = OPTIONAL
 NA = NOT AVAILABLE

abbreviation	description	note \ model
PL	Private label	
1.0 MECHANICAL CONFIGURATION		
AM - ANTIVIBRANT MOUNTING		
ATV	rubber type antivibrant mounting	AM variant
CC	copper tubes and copper fins condenser	
CF	condenser filter	NA with GPC
CG	condenser treatment (ElectroFin)	NA with CV
CV	epoxy coated condenser coil	NA with CG
FRAME COLOUR		
-	standard color RAL 7035	
CRAL	customized color	
GALV	galvanized version (main frame and panels)	
GPC	condenser metallic grid protection	NA with CF
LNJ	low noise version	include: compr. Jackets, IR.
SSF	Stainless steel frame	
2.0 HYDRIC CIRCUIT CONFIGURATION		
B1	evaporator inlet water temperature sensor (work probe)	
B2	evaporator outlet water temperature sensor (antifreeze probe)	
BPA	automatic by-pass	BPA kit
VBA	automatic by-pass valve	BPA kit
CIRCUIT CONFIGURATION		
OWC	open circuit configuration	CIRCUIT CONFIGURATION variant
CWC	closed circuit configuration	CIRCUIT CONFIGURATION variant
VSW	water safety relief valve	CWC kit
ASFA	automatic air vent	XV kit, replaces SFA, NA with OWC
RA	automatic feeder with check valve and filter incorporated	XV kit, NA with OWC
XV	expansion vessel	XV kit, NA with OWC
FL	flow switch	
MP - PROCESS PUMP		
WP	single pump P3	MP variant
DP	double pump P3	MP variant
NT.DP	no tank double pump P3	MP variant
PH	single pump P5	MP variant
DPH	double pump P5	MP variant
NT.DPH	no tank double pump P5	MP variant
GL50	special pump for glycol concentration from 30% to 50%	available only with WP or PH
GL50D	special double pump for glycol concentration from 30% to 50%	available only with DP or DPH
VRAP	double pump check valve	DP and DPH kit
VTPD	double pump ball valve	DP and DPH kit
MW	water pressure gauge	OPT with NP
RAGE	evaporator antifreeze heater	
RAGP	pump antifreeze heater	available only with WP or PH
RAGDP	pump antifreeze heater	available only with DP or DPH
RAGT	tank antifreeze heater	NA with NT
SCA - WATER HEAT EXCHANGER (EVAPORATOR)		
CX	self-cleaning coaxial evaporator	SCA variant
B-ES	brased plate evaporator	SCA variant
ST	shell and tube evaporator	SCA variant
SFA	manual air vent	
T - TANK		
NT	no tank	T variant
NT.NP	no tank no pump	T variant
CST	tank in carbon steel	T variant
CST.NP	tank in carbon steel no pump	T variant, NA with OWC
SST	tank in stainless steel	T variant
SST.NP	tank in stainless steel no pump	T variant, NA with OWC
SST.B-ES	tank in stainless steel with plate evaporator	T variant
LLA	electric float low water level alarm	NA with NT
RM	manual filling cap	NA with NT
SFAS	tank manual air vent	NA with NT
VSCS	tank water drain valve	NA with NT
VSWs	tank safety relief valve	NA with OWC or NT
VSC	water drain valve	
VTP	ball valve between tank and pump	NA with NP
WATER CONNECTIONS		
-	flanged	
-	threaded	

PROCESS COOLING APPLICATION **CSE**

STD = STANDARD
 OPT = OPTIONAL
 NA = NOT AVAILABLE

abbreviation	description	note \ model
3.0 REFRIGERANT CIRCUIT CONFIGURATION		
CSV	compressors shut off valve	
DRV	dual safety relief valve	DRV kit
RSAP	VSAP changeover valve	DRV kit
RSBP	VSBP changeover valve	DRV kit
EXPANSION VALVE		
VTS	thermostatic expansion valve	EXPANSION VALVE variant
ETS	electronic expansion valve	ETS kit, EXPANSION VALVE variant
B11, B12	compressor suction temperature sensor for the electronic exp. valve	ETS kit
B13, B14	low pressure trasducer for the electronic expansion valve	ETS kit
FLT	dehydrating filter	
HP	high pressure switch	
HPG	high pressure gauge	
HW	leaving water temperature between 15°C to 20degC	
LIQ	sight glass	
LP	low pressure switch	
LPG	low pressure gauge	
LT	low ambient temperature until -25°C	include: RC, IR, EB.
LW	low water temperature until -10°C outlet	include: RC, IR, thicker insulation.
MC - COMPRESSOR		
-	scroll	
OIL	sight glass for equalisation line of oil	
RC	compressor crankcase heater	
NUMBER OF REFRIGERANT CIRCUITS		
-	single refrigerant circuit	
DC	double refrigerant circuit	NA with ST until model CSE.100
PDS		
-	partial desuperheater	
PMC		
-	hot gas bypass	PMC kit
RGC	hot gas shut off valve	PMC kit
Y19, Y20	hot gas bypass valve (solenoid valve)	PMC kit
SCE		
-	air heat exchanger (condenser)	
SCR		
-	charge valve (schrader)	
VSAP		
-	high pressure safety relief valve	
VSBP		
-	low pressure safety relief valve	
Y4, Y8	liquid line solenoid valve	
4.0 ELECTRIC CIRCUIT CONFIGURATION		
CONTROLLER		
μC2SE	microchiller 2SE base board (24V)	
EB	control box heater	
EL	air/liquid heat exchanger for the control box cooling	NA with EV
ELECTRICAL FEED		
-	400V/3ph/50Hz without neutral	
EV	forced ventilation of the control box	NA with EL
HRM	Hours run meter	
MC - COMPRESSOR		
IRC	inverter for compressors	include: DC, i CHILL
SF	soft start	
MP - PROCESS PUMP		
AT	automatic management pumps	DP and DPH kit
IRP	inverter pump speed regulation	available only with WP
IRD	inverter pump speed regulation	available only with DP
IRPH	inverter pump speed regulation	available only with PH
IRDPH	inverter pump speed regulation	available only with DPH
MV - CENTRIFUGAL FAN MOTOR		
PV	fans pressure switch	
IR	inverter fan speed control	IR kit, replaces PV
B5÷6	high pressure trasducer	IR kit
OFC		
-	on-off compressors signal	
OFR	remote control (on/off)	NA with OFRC
OFRC	remote control display with on/off remote+alarm management	NA with OFR
PD		
-	display cover protection	
PFC		
-	power Factor Correction, cos(phi) > 0,95	
PROTECTION RATING		
-	IP44	STD with IR
-	IP54	OPT with IR
Q0		
-	general switch of the chiller	
RS485	serial card for modbus RS485	NA with OFRC
RVG		
-	volt-metric relay (phase sequence relay CSF included)	
TROPICALIZED VERSION		
-	max ambient temperature until 35°C	
GENERAL ALARM		
VAL	voltage free-contact for general alarm	
-	acustic and visual alarm	available with GENERAL ALARM
REMOTE ON/OFF		
-	voltage-free contact for remote on/off	

030	038	045	061	075	100	130	160	185	230	280	340	370
-----	-----	-----	-----	-----	-----	-----	-----	-----	-----	-----	-----	-----

OPT	OPT	OPT	OPT	OPT	OPT	OPT	OPT	OPT	OPT	OPT	OPT	OPT	OPT
NA	NA	NA	OPT	OPT	OPT	OPT	OPT	OPT	OPT	OPT	OPT	OPT	OPT
NA	NA	NA	OPT	OPT	OPT	OPT	OPT	OPT	OPT	OPT	OPT	OPT	OPT
NA	NA	NA	NA	NA	NA	NA	NA	NA	OPT	OPT	OPT	OPT	OPT
STD	STD	STD	STD	STD	STD	STD	STD	STD	STD	STD	STD	STD	STD
OPT	OPT	OPT	OPT	OPT	OPT	OPT	OPT	OPT	OPT	OPT	OPT	OPT	OPT
OPT	OPT	OPT	OPT	OPT	OPT	OPT	OPT	OPT	OPT	OPT	OPT	OPT	OPT
OPT	OPT	OPT	OPT	OPT	OPT	OPT	OPT	OPT	OPT	OPT	OPT	OPT	OPT
STD	STD	STD	STD	STD	STD	STD	STD	STD	STD	STD	STD	STD	STD
STD	STD	STD	STD	STD	STD	STD	STD	STD	STD	STD	STD	STD	STD
OPT	OPT	OPT	STD	STD	STD	STD	STD	STD	STD	STD	STD	STD	STD
OPT	OPT	OPT	OPT	OPT	OPT	OPT	OPT	OPT	OPT	OPT	OPT	OPT	OPT
STD	STD	STD	STD	STD	STD	STD	STD	STD	STD	STD	STD	STD	STD
STD	STD	STD	STD	STD	STD	STD	STD	STD	STD	STD	STD	STD	STD
STD	STD	STD	STD	STD	STD	STD	STD	STD	STD	STD	STD	STD	STD
STD	STD	STD	STD	STD	STD	STD	STD	STD	STD	STD	STD	STD	STD
STD	STD	STD	STD	STD	STD	STD	STD	STD	STD	STD	STD	STD	STD
STD	STD	STD	STD	STD	STD	STD	STD	STD	STD	STD	STD	STD	STD
STD	STD	STD	STD	STD	STD	STD	STD	STD	STD	STD	STD	STD	STD
STD	STD	STD	STD	STD	STD	STD	STD	STD	STD	STD	STD	STD	STD
STD	STD	STD	STD	STD	STD	STD	STD	STD	STD	STD	STD	STD	STD
STD	STD	STD	STD	STD	STD	STD	STD	STD	STD	STD	STD	STD	STD
STD	STD	STD	STD	STD	STD	STD	STD	STD	STD	STD	STD	STD	STD
STD	STD	STD	STD	STD	STD	STD	STD	STD	STD	STD	STD	STD	STD
STD	STD	STD	STD	STD	STD	STD	STD	STD	STD	STD	STD	STD	STD

STD	STD	STD	STD	STD	STD	STD	STD	STD	STD	STD	STD	STD	STD
OPT	OPT	OPT	OPT	OPT	OPT	OPT	OPT	OPT	OPT	OPT	OPT	OPT	OPT
NA	NA	NA	NA	NA	NA	OPT	OPT	OPT	OPT	OPT	OPT	OPT	OPT
STD	STD	STD	STD	STD	STD	STD	STD	STD	STD	STD	STD	STD	STD
OPT	OPT	OPT	OPT	OPT	OPT	OPT	OPT	OPT	STD	STD	STD	STD	STD
OPT	OPT	OPT	OPT	OPT	OPT	STD	STD	STD	STD	STD	STD	STD	STD
OPT	OPT	OPT	OPT	OPT	OPT	NA	NA	NA	NA	NA	NA	NA	NA
OPT	OPT	OPT	OPT	OPT	OPT	OPT	OPT	OPT	OPT	OPT	OPT	OPT	OPT
NA	NA	NA	OPT	OPT	OPT	OPT	OPT	OPT	OPT	OPT	OPT	OPT	OPT
NA	NA	NA	OPT	OPT	OPT	OPT	OPT	OPT	OPT	OPT	OPT	OPT	OPT
NA	NA	NA	OPT	OPT	OPT	OPT	OPT	OPT	OPT	OPT	OPT	OPT	OPT
STD	STD	STD	STD	STD	STD	STD	STD	STD	STD	STD	STD	STD	STD
OPT	OPT	OPT	OPT	OPT	OPT	STD	STD	STD	STD	STD	STD	STD	STD
OPT	OPT	OPT	OPT	OPT	OPT	STD	STD	STD	STD	STD	STD	STD	STD
OPT	OPT	OPT	OPT	OPT	OPT	OPT	OPT	OPT	OPT	OPT	OPT	OPT	OPT
OPT	OPT	OPT	OPT	OPT	OPT	OPT	OPT	OPT	OPT	OPT	OPT	OPT	OPT
OPT	OPT	OPT	OPT	OPT	OPT	NA	NA	NA	NA	NA	NA	NA	NA
NA	NA	NA	NA	NA	NA	OPT	OPT	OPT	OPT	OPT	OPT	OPT	OPT
STD	STD	STD	STD	STD	STD	STD	STD	STD	STD	STD	STD	STD	STD
OPT	OPT	OPT	OPT	OPT	OPT	OPT	OPT	OPT	OPT	OPT	OPT	OPT	OPT
STD	STD	STD	STD	STD	STD	STD	STD	STD	STD	STD	STD	STD	STD
OPT	OPT	OPT	OPT	OPT	OPT	OPT	OPT	OPT	OPT	OPT	OPT	OPT	OPT
OPT	OPT	OPT	OPT	OPT	OPT	OPT	OPT	OPT	STD	STD	STD	STD	STD
STD	STD	STD	STD	STD	STD	STD	STD	STD	STD	STD	STD	STD	STD
STD	STD	STD	STD	STD	STD	STD	STD	STD	STD	STD	STD	STD	STD
OPT	OPT	OPT	OPT	OPT	OPT	OPT	OPT	OPT	OPT	OPT	OPT	OPT	OPT
STD	STD	STD	STD	STD	STD	STD	STD	STD	STD	STD	STD	STD	STD
STD	STD	STD	STD	STD	STD	STD	STD	STD	STD	STD	STD	STD	STD



PROCESS COOLING APPLICATION

CSE

abbreviation	description	note \ model
5.0 PACKING		
ANS	rubber pad antivibrating (shipment)	
NCC - STANDARD PACKING		
NCC1	full cardboard protection with wooden spacers on bottom	
NCC2	vertical cardboard protection on unit corners, nylon covering and wooden spacers on bottom	
WC - WOODEN PROTECTION		
WCA	wooden cage	WC variant
WCR	wooden crate	WC variant

STD = STANDARD
 OPT = OPTIONAL
 NA = NOT AVAILABLE

Doc. code: SCO-PCA-CSE
 Area: IPT-CS

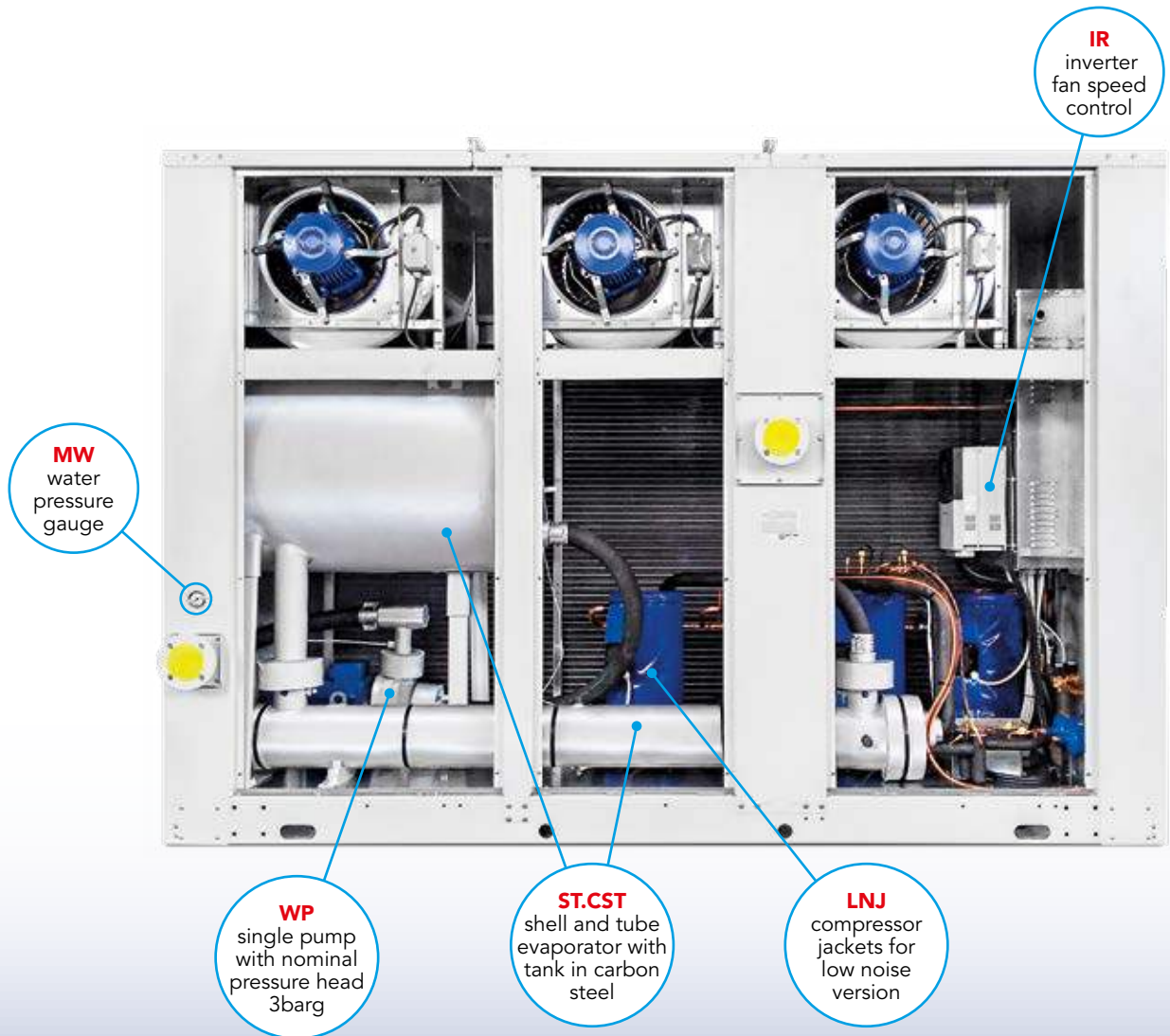

030	038	045	061	075	100	130	160	185	230	280	340	370	
NA	NA	NA	NA	NA	NA	OPT	OPT	OPT	OPT	OPT	OPT	OPT	
STD	STD	STD	NA	NA	NA	NA	NA	NA	NA	NA	NA	NA	
NA	NA	NA	STD	STD	STD	STD	STD	STD	STD	STD	STD	STD	
OPT	OPT	OPT	OPT	OPT	OPT	OPT	OPT	OPT	OPT	OPT	OPT	OPT	
OPT	OPT	OPT	OPT	OPT	OPT	OPT	OPT	OPT	OPT	OPT	OPT	OPT	

Updated on: 18/07/2017
 Revision number: 4

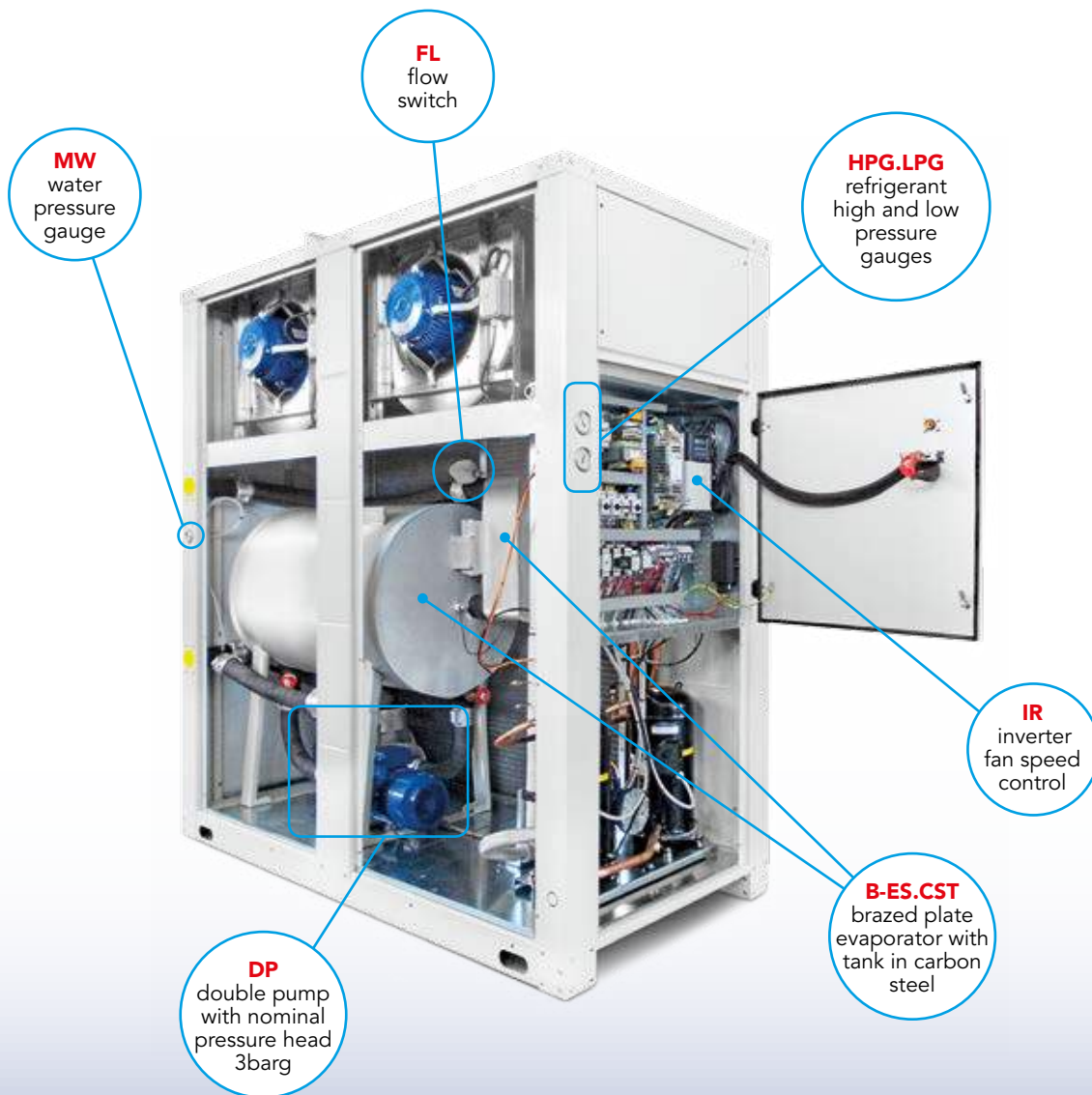

ENR models 001, 002

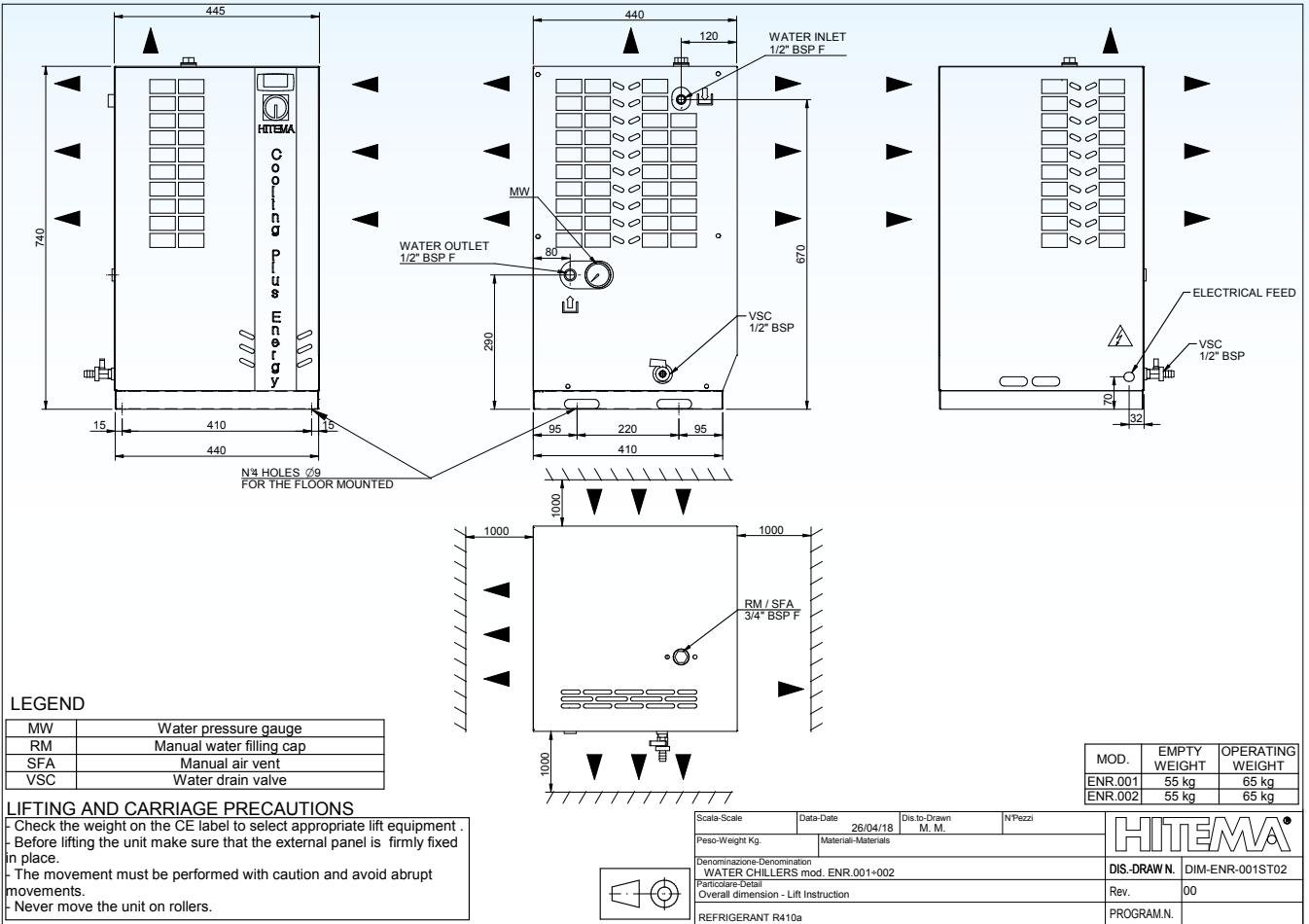

ENR models 003, 004, 005

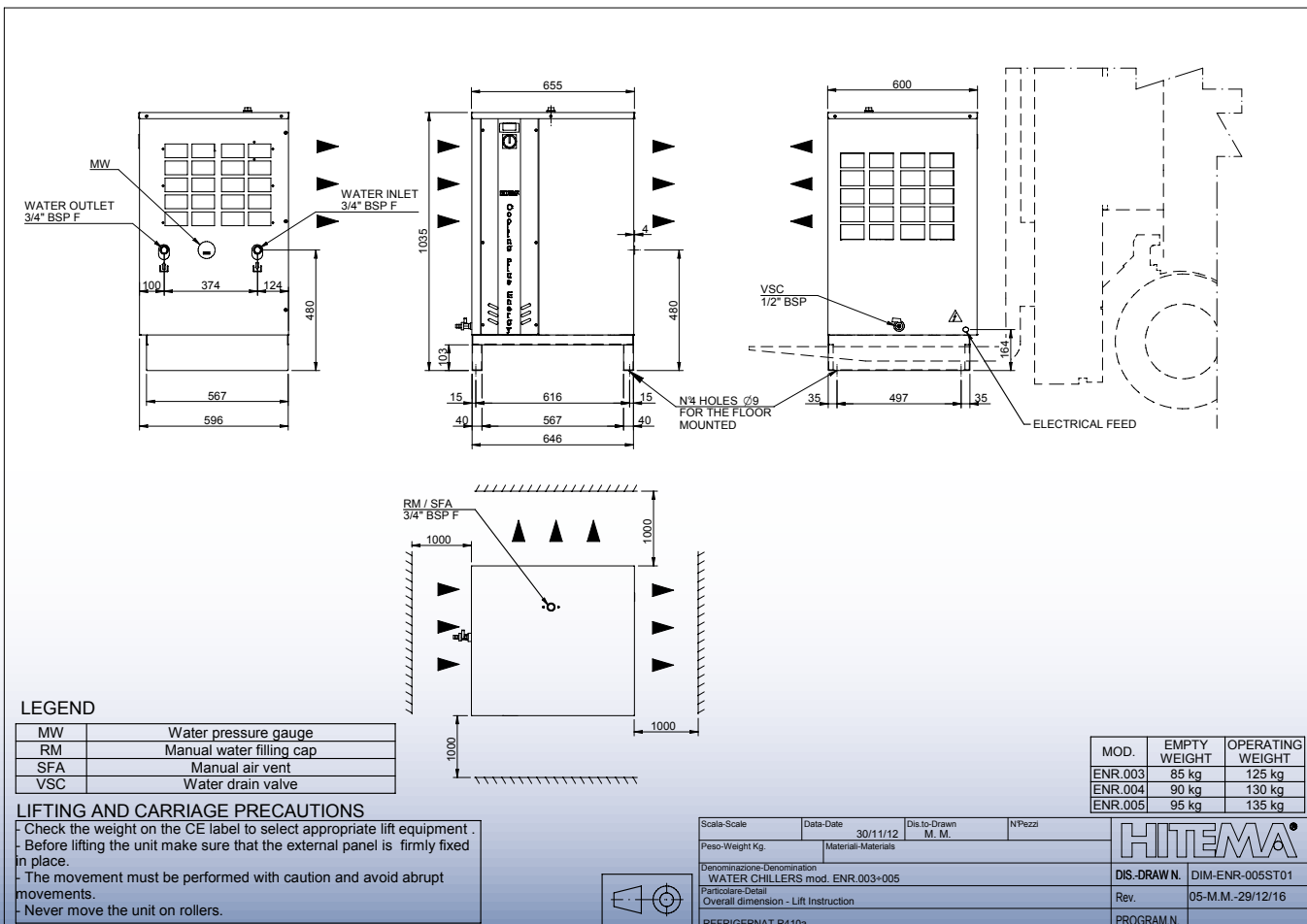

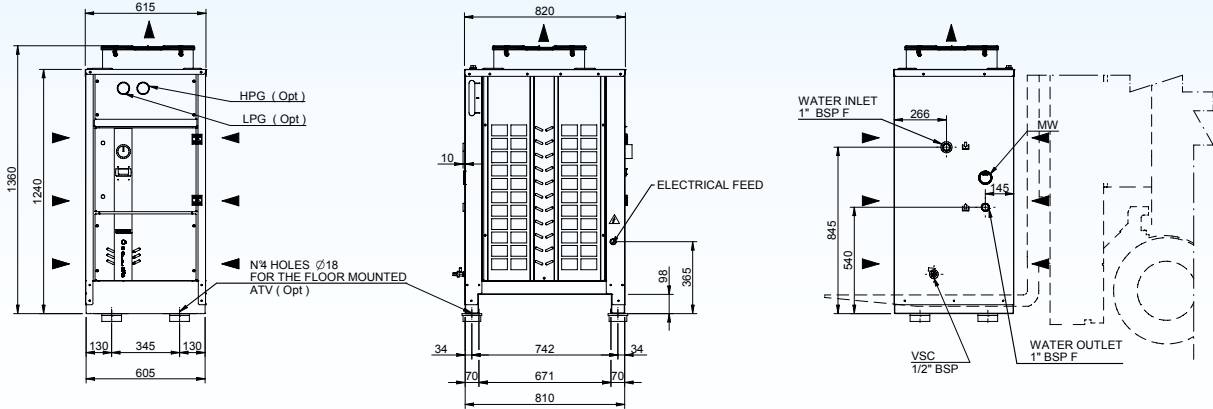

LEGEND

HPG	High pressure gauge (Opt)
LPG	Low pressure gauge (Opt)
MW	Water pressure gauge
RM	Manual water filling cap
SFA	Manual air vent
VSC	Water drain valve
ATV	Rubber type antivibrant mounting (Opt)

LIFTING AND CARRIAGE PRECAUTIONS

- Check the weight on the CE label to select appropriate lift equipment .
- Before lifting the unit make sure that the external panel is firmly fixed in place.
- The movement must be performed with caution and avoid abrupt movements.
- Never move the unit on rollers.

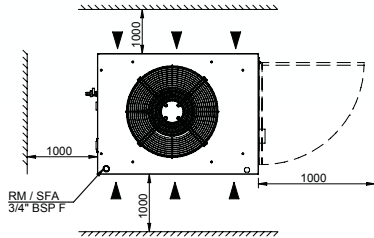

MOD.	EMPTY WEIGHT	OPERATING WEIGHT
ENR.008	160 kg	210 kg
ENR.010	165 kg	215 kg
ENR.012	170 kg	220 kg
ENR.016	175 kg	225 kg

Scale-Scala	Data-Date	24/07/15	Dis.to-Drawn	M. M.	N°Pezzi	HITEMA	
Peso-Weight Kg.	Material-Materials						
Denominazione-Denomination						DIS-DRAW N.	DIM-ENR-008ST03
WATER CHILLERS mod. ENR.008+016						Rev.	01-M.M.-29/12/16
Particolare-Detail						PROGRAM.N.	
Overall dimension - Lift Instruction							
REFRIGERANT R410a							

Copyright - Nachdruck verboten

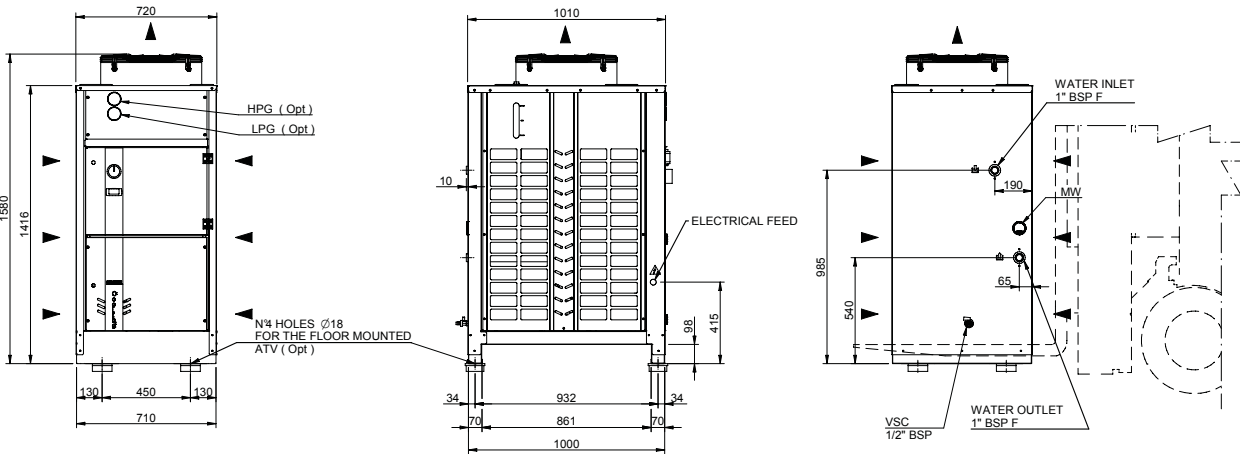

LEGEND

HPG	High pressure gauge (Opt)
LPG	Low pressure gauge (Opt)
MW	Water pressure gauge
RM	Manual water filling cap
SFA	Manual air vent
VSC	Water drain valve
ATV	Rubber type antivibrant mounting (Opt)

LIFTING AND CARRIAGE PRECAUTIONS

- Check the weight on the CE label to select appropriate lift equipment .
- Before lifting the unit make sure that the external panel is firmly fixed in place.
- The movement must be performed with caution and avoid abrupt movements.
- Never move the unit on rollers.

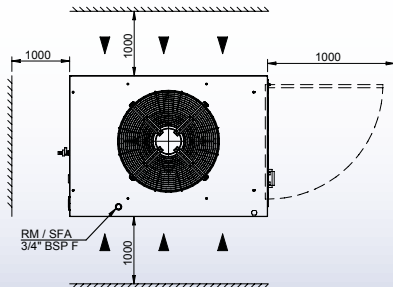

MOD.	EMPTY WEIGHT	OPERATING WEIGHT
ENR.018	210 kg	340 kg
ENR.022	260 kg	390 kg

Scale-Scala	Data-Date	13/01/14	Dis.to-Drawn	B.C.	N°Pezzi	HITEMA	
Peso-Weight Kg.	Material-Materials						
Denominazione-Denomination						DIS-DRAW N.	DIM-ENR-018ST01
WATER CHILLERS mod. ENR.018+022						Rev.	02-M.M.-29/12/16
Particolare-Detail						PROGRAM.N.	
Overall dimension - Lift Instruction							
REFRIGERANT R410a							

Copyright - Nachdruck verboten

ENR models 030, 038, 045, 055

LEGEND

HPG	High pressure gauge (Opt)
LPG	Low pressure gauge
MW	Water pressure gauge
RM	Manual water filling cap
SFA	Manual air vent
VSC	Water drain valve
ATV	Rubber type antivibrant mounting (Opt)

LIFTING AND CARRIAGE PRECAUTIONS

- Check the weight on the CE label to select appropriate lift equipment .
- Before lifting the unit make sure that the external panel is firmly fixed in place.
- To use only lifting points provided.
- The chains or slings must be of equal length.
- To use a spread-bar to avoid damage to the unit.
- The movement must be performed with caution and avoid abrupt movements.
- Never move the unit on rollers.

Scale-Scala	Data-Date	11/04/13	Dis.to-Drawn	M. M.	N°Pezzi
Peso-Weight Kg.	Material-Materials				
Denominazione-Denomination	WATER CHILLERS mod. ENR.030+055				
Particolare-Detail	Overall dimension - Lift Instruction				
REFRIGERANT R410a					

MOD.	EMPTY WEIGHT	OPERATING WEIGHT
ENR.030	375 kg	675 kg
ENR.038	390 kg	690 kg
ENR.045	410 kg	710 kg
ENR.055	500 kg	800 kg

Copyright - Nachdruck verboten

ENR models 061, 070, 075, 090, 100

LEGEND

HPG	High pressure gauge
LPG	Low pressure gauge
MW	Water pressure gauge
RM	Manual water filling cap
SFA	Manual air vent
VSC	Water drain valve
ATV	Rubber type antivibrant mounting (Opt)

LIFTING AND CARRIAGE PRECAUTIONS

- Check the weight on the CE label to select appropriate lift equipment .
- Before lifting the unit make sure that the external panel is firmly fixed in place.
- To use only lifting points provided.
- The chains or slings must be of equal length.
- To use a spread-bar to avoid damage to the unit.
- The movement must be performed with caution and avoid abrupt movements.
- Never move the unit on rollers.

Scale-Scala	Data-Date	21/06/13	Dis.to-Drawn	M. M.	N°Pezzi
Peso-Weight Kg.	Material-Materials				
Denominazione-Denomination	WATER CHILLERS mod. ENR.061+100				
Particolare-Detail	Overall dimension - Lift Instruction				
REFRIGERANT R410a					

MOD.	EMPTY WEIGHT	OPERATING WEIGHT
ENR.061	740 kg	1180 kg
ENR.070	765 kg	1185 kg
ENR.075	770 kg	1190 kg
ENR.090	785 kg	1205 kg
ENR.100	890 kg	1310 kg

Copyright - Nachdruck verboten

With DPH option the chiller width is 200mm more.
 Attention: the weight will be different.

LEGEND

HPG	High pressure gauge
LPG	Low pressure gauge
MW	Water pressure gauge
RM	Manual water filling cap
SFAS	Tank manual air vent
SFA	Manual air vent
VSCS	Tank water drain valve
ATS	Spring type antivibrant mounting (Opt)
ATV	Rubber type antivibrant mounting (Opt)

LIFTING AND CARRIAGE PRECAUTIONS

- Check the weight on the CE label to select appropriate lift equipment .
- Before lifting the unit make sure that the external panel is firmly fixed in place.
- To use only lifting points provided.
- The chains or slings must be of equal length.
- To use a spread-bar to avoid damage to the unit.
- The movement must be performed with caution and avoid abrupt movements.
- Never move the unit on rollers.
- Never lift the unit using a fork-lift.

Scale-Scala	Date-Date	Dis. Io-Drawn	N°Pezzi
	02/07/13	B.C.	
Peso-Weight Kg.	Materiali-Materials		
Denominazione-Denomination			
WATER CHILLERS mod. ENR.130+185/CS.ST.T.WP.			
Particolare-Detail			
Overall dimension - Lift Instruction			
REFRIGERANT R410a		DIS.-DRAW N.	DIM-ENR-130ST01
		Rev.	01 - B.C. - 19/12/16
		PROGRAMM.	

MOD.	EMPTY WEIGHT	OPERATING WEIGHT	N° FANS
ENR.130	1190 kg	1610 kg	2
ENR.160	1260 kg	1695 kg	3
ENR.185	1320 kg	1760 kg	3

Copyright - Nachdruck verboten

ENR models 130, 160, 185

With DP and DPH option the chiller width is 200mm more.
 Attention: the weight will be different.

LEGEND

HPG	High pressure gauge
LPG	Low pressure gauge
MW	Water pressure gauge
RM	Manual water filling cap
SFAS	Tank manual air vent
SFA	Manual air vent
VSCS	Tank water drain valve
ATS	Spring type antivibrant mounting (Opt)
ATV	Rubber type antivibrant mounting (Opt)

LIFTING AND CARRIAGE PRECAUTIONS

- Check the weight on the CE label to select appropriate lift equipment .
- Before lifting the unit make sure that the external panel is firmly fixed in place.
- To use only lifting points provided.
- The chains or slings must be of equal length.
- To use a spread-bar to avoid damage to the unit.
- The movement must be performed with caution and avoid abrupt movements.
- Never move the unit on rollers.
- Never lift the unit using a fork-lift.

Scale-Scala	Date-Date	Dis. Io-Drawn	N°Pezzi
	14/03/16	M.M.	
Peso-Weight Kg.	Materiali-Materials		
Denominazione-Denomination			
WATER CHILLERS mod. ENR.200/CS.ST.T.WP.			
Particolare-Detail			
Overall dimension - Lift Instruction			
REFRIGERANT R410a		DIS.-DRAW N.	DIM-ENR-200ST01
		Rev.	01 - B.C. - 11/01/17
		PROGRAMM.	

MOD.	EMPTY WEIGHT	OPERATING WEIGHT
ENR.200	1815 kg	2275 kg

Copyright - Nachdruck verboten

ENR model 200

ENR models 230, 280, 340

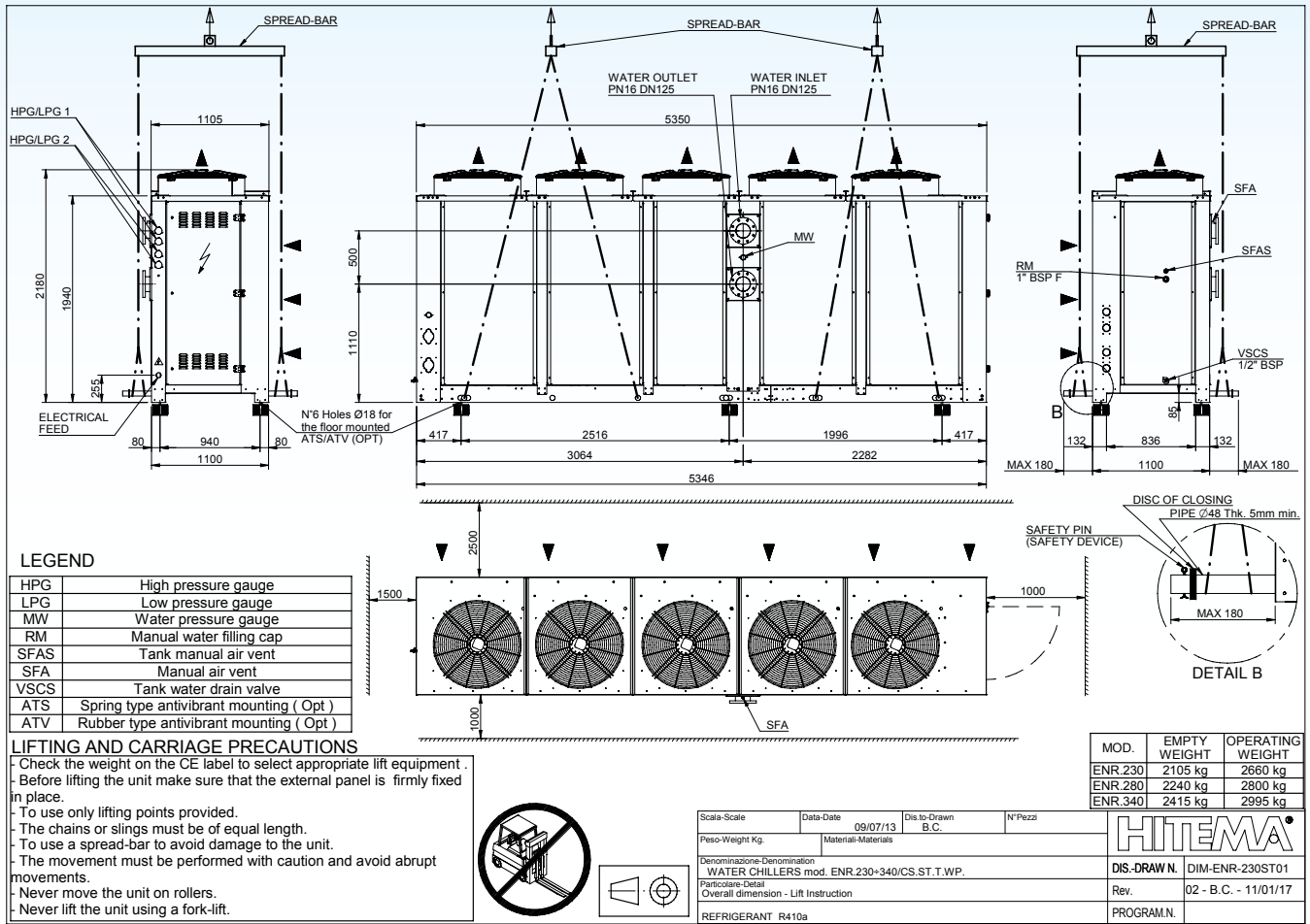

ENR models 370, 430, 480

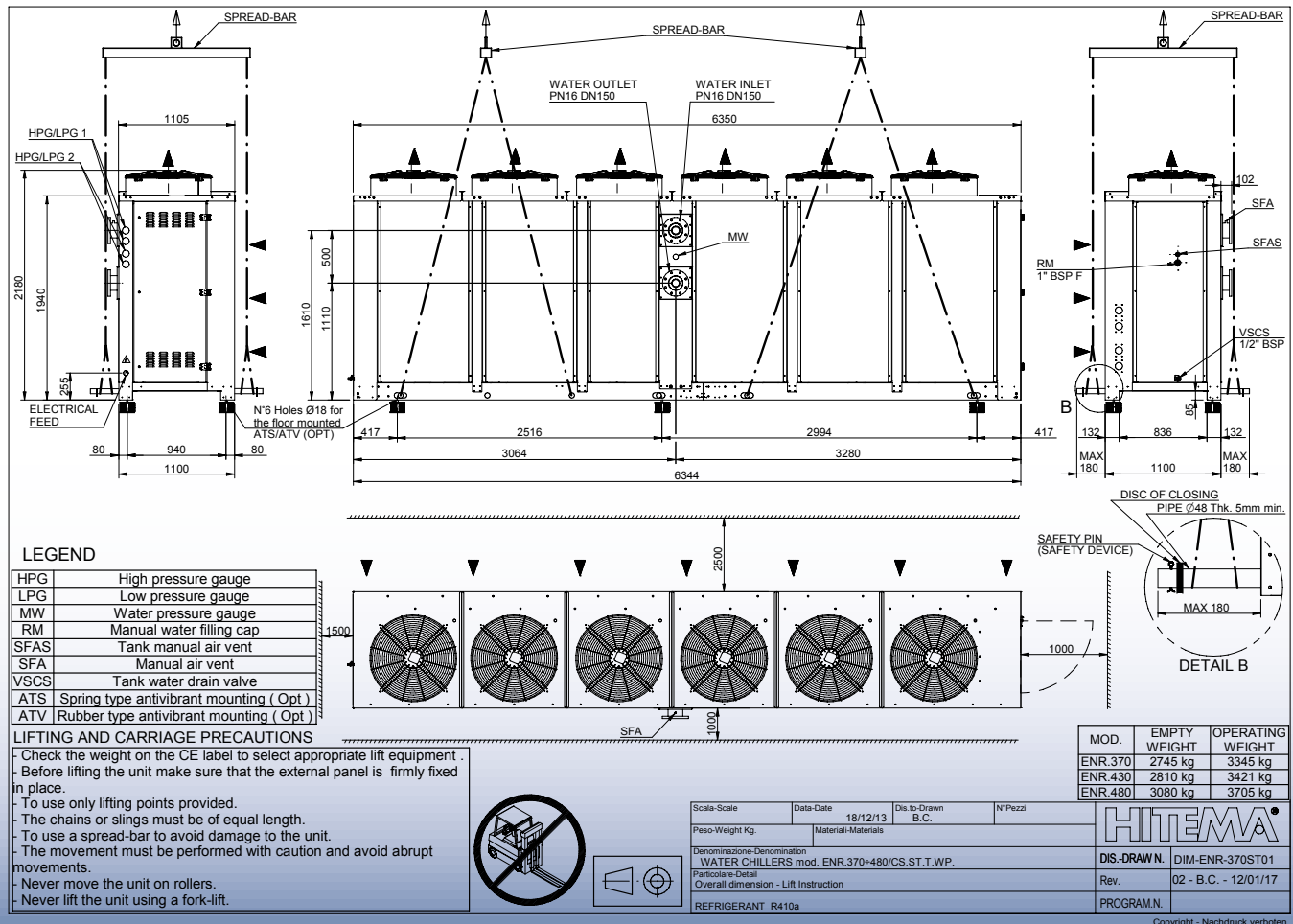

LEGEND

HPG	High pressure gauge (Opt)
LPG	Low pressure gauge
MW	Water pressure gauge
RM	Manual water filling cap
VSC	Water drain valve
SFAF	Free cooling manual air vent
VSCF	Free cooling water drain valve
PD	Display cover protection
ATV	Rubber type antivibrant mounting (Opt)

LIFTING AND CARRIAGE PRECAUTIONS

- Check the weight on the CE label to select appropriate lift equipment .
- Before lifting the unit make sure that the external panel is firmly fixed in place.
- To use only lifting points provided.
- The chains or slings must be of equal length.
- To use a spread-bar to avoid damage to the unit.
- The movement must be performed with caution and avoid abrupt movements.
- Never move the unit on rollers.

Scale- Scale	Date- Date	Dis. to- Drawn	N°Pezzi
Peso- Weight Kg.	Material- Materials	HITEMA	
Denominazione- Denomination			
Particolare- Detail		Rev.	03- M. M. - 12/01/17
Overall dimension - Lift Instruction		PROGRAM.N.	
REFRIGERANT R410a			

MOD.	EMPTY WEIGHT	OPERATING WEIGHT
ENRF.022	460 kg	745 kg
ENRF.030	470 kg	755 kg

Copyright - Nachdruck verboten

ENRF models 022, 030

LEGEND

HPG	High pressure gauge
LPG	Low pressure gauge
MW	Water pressure gauge
RM	Manual water filling cap
VSC	Water drain valve
SFAF	Free cooling manual air vent
VSCF	Free cooling water drain valve
PD	Display cover protection
ATV	Rubber type antivibrant mounting (Opt)

LIFTING AND CARRIAGE PRECAUTIONS

- Check the weight on the CE label to select appropriate lift equipment .
- Before lifting the unit make sure that the external panel is firmly fixed in place.
- To use only lifting points provided.
- The chains or slings must be of equal length.
- To use a spread-bar to avoid damage to the unit.
- The movement must be performed with caution and avoid abrupt movements.
- Never move the unit on rollers.

Scale- Scale	Date- Date	Dis. to- Drawn	N°Pezzi
Peso- Weight Kg.	Material- Materials	HITEMA	
Denominazione- Denomination			
Particolare- Detail		Rev.	02- M. M. - 13/01/17
Overall dimension - Lift Instruction		PROGRAM.N.	
REFRIGERANT R410a			

MOD.	EMPTY WEIGHT	OPERATING WEIGHT
ENRF.038	635 kg	930 kg
ENRF.045	650 kg	950 kg
ENRF.055	740 kg	1035 kg

Copyright - Nachdruck verboten

ENRF models 038, 045, 055

ENRF models 061, 070, 075, 090

LEGEND

HPG	High pressure gauge
LPG	Low pressure gauge
MW	Water pressure gauge
RM	Manual water filling cap
VSC	Water drain valve
SFAF	Free cooling manual air vent
VSCF	Free cooling water drain valve
ATS	Spring type antivibrant mounting (Opt)
ATV	Rubber type antivibrant mounting (Opt)

LIFTING AND CARRIAGE PRECAUTIONS

- Check the weight on the CE label to select appropriate lift equipment.
- Before lifting the unit make sure that the external panel is firmly fixed in place.
- To use only lifting points provided.
- The chains or slings must be of equal length.
- To use a spread-bar to avoid damage to the unit.
- The movement must be performed with caution and avoid abrupt movements.
- Never move the unit on rollers.
- Never lift the unit using a fork-lift.

MOD.	EMPTY WEIGHT	OPERATING WEIGHT	N° FANS
ENRF.061	1120 kg	1590 kg	2
ENRF.070	1125 kg	1595 kg	2
ENRF.075	1150 kg	1620 kg	2
ENRF.090	1180 kg	1650 kg	3

Scale-Scale	Date-Date	30/09/13	Dis. to Drawn	N°Pezzi
Peso-Weight Kg.	Material-Materials		B.C.	
Denominazione-Denomination				
WATER CHILLERS mod. ENRF.061+090/T.W.P.				
Particolare-Detail				
Overall dimension - Lift Instruction				
REFRIGERANT R410a				
DIS.-DRAW N.				
DIM-ENRF-061ST01				
Rev.				
04-M.M.-16/01/17				
PROGRAM.N.				

ENRF models 100

LEGEND

HPG	High pressure gauge
LPG	Low pressure gauge
MW	Water pressure gauge
RM	Manual water filling cap
VSC	Water drain valve
SFAF	Free cooling manual air vent
VSCF	Free cooling water drain valve
ATS	Spring type antivibrant mounting (Opt)
ATV	Rubber type antivibrant mounting (Opt)

LIFTING AND CARRIAGE PRECAUTIONS

- Check the weight on the CE label to select appropriate lift equipment.
- Before lifting the unit make sure that the external panel is firmly fixed in place.
- To use only lifting points provided.
- The chains or slings must be of equal length.
- To use a spread-bar to avoid damage to the unit.
- The movement must be performed with caution and avoid abrupt movements.
- Never move the unit on rollers.
- Never lift the unit using a fork-lift.

MOD.	EMPTY WEIGHT	OPERATING WEIGHT	N° FANS
ENRF.100	1480 kg	1970 kg	3

Scale-Scale	Date-Date	23/01/14	Dis. to Drawn	N°Pezzi
Peso-Weight Kg.	Material-Materials		B.C.	
Denominazione-Denomination				
WATER CHILLERS mod. ENRF.100/CS.T.W.P.				
Particolare-Detail				
Overall dimension - Lift Instruction				
REFRIGERANT R410a				
DIS.-DRAW N.				
DIM-ENRF-100ST0100				
Rev.				
02 - B.C. - 12/01/17				
PROGRAM.N.				

LEGEND

HPG	High pressure gauge
LPG	Low pressure gauge
MW	Water pressure gauge
RM	Manual water filling cap
SFAS	Tank manual air vent
SFA	Manual air vent
VSCS	Tank water drain valve
SFAF	Free cooling manual air vent
VSCF	Free cooling water drain valve
ATS	Spring type antivibrant mounting (Opt)
ATV	Rubber type antivibrant mounting (Opt)

LIFTING AND CARRIAGE PRECAUTIONS

- Check the weight on the CE label to select appropriate lift equipment .
- Before lifting the unit make sure that the external panel is firmly fixed in place.
- To use only lifting points provided.
- The chains or slings must be of equal length.
- To use a spread-bar to avoid damage to the unit.
- The movement must be performed with caution and avoid abrupt movements.
- Never move the unit on rollers.
- Never lift the unit using a fork-lift.

Scale-Scale	Date-Date	Dis-Drawn	N°Pezzi
	29/06/16	M.M.	
Peso-Weight Kg	Material-Materials	HITEMA	
Denominazione-Denomination WATER CHILLERS mod. ENRF.130/CS.T.WP.			
Particolare-Detail Overall dimension - Lift Instruction			
REFRIGERANT R410a		DIS-DRAW N.	DIM-ENRF-130ST01
		Rev.	01 - B.C. - 12/01/17
		PROGRAMN.	

Copyright - Nachdruck verboten

ENRF models 130

LEGEND

HPG	High pressure gauge
LPG	Low pressure gauge
MW	Water pressure gauge
RM	Manual water filling cap
SFAS	Tank manual air vent
SFA	Manual air vent
VSCS	Tank water drain valve
SFAF	Free cooling manual air vent
VSCF	Free cooling water drain valve
ATS	Spring type antivibrant mounting (Opt)
ATV	Rubber type antivibrant mounting (Opt)

LIFTING AND CARRIAGE PRECAUTIONS

- Check the weight on the CE label to select appropriate lift equipment .
- Before lifting the unit make sure that the external panel is firmly fixed in place.
- To use only lifting points provided.
- The chains or slings must be of equal length.
- To use a spread-bar to avoid damage to the unit.
- The movement must be performed with caution and avoid abrupt movements.
- Never move the unit on rollers.
- Never lift the unit using a fork-lift.

Scale-Scale	Date-Date	Dis-Drawn	N°Pezzi
	23/01/14	B.C.	
Peso-Weight Kg	Material-Materials	HITEMA	
Denominazione-Denomination WATER CHILLER mod. ENRF.160+185/CS.ST.T.WP			
Particolare-Detail OVERALL DIMENSIONS - LIFT INSTRUCTIONS			
REFRIGERANT R410a		DIS-DRAW N.	DIM-ENRF-160ST0100
		Rev.	02 - B.C. - 12/01/17
		PROGRAMN.	

Copyright - Nachdruck verboten

ENRF models 160, 185

ENRF models 200, 230, 280, 340, 370

LEGEND

HPG	High pressure gauge
LPG	Low pressure gauge
MW	Water pressure gauge
RM	Manual water filling cap
SFAS	Tank manual air vent
SFA	Manual air vent
VSCS	Tank water drain valve
SFAF	Free cooling manual air vent
VSCF	Free cooling water drain valve
ATS	Spring type antivibrant mounting (Opt)
ATV	Rubber type antivibrant mounting (Opt)

LIFTING AND CARRIAGE PRECAUTIONS

- Check the weight on the CE label to select appropriate lift equipment .
- Before lifting the unit make sure that the external panel is firmly fixed in place.
- To use only lifting points provided.
- The chains or slings must be of equal length.
- To use a spread-bar to avoid damage to the unit.
- The movement must be performed with caution and avoid abrupt movements.
- Never move the unit on rollers.
- Never lift the unit using a fork-lift.

MOD.	EMPTY WEIGHT	OPERATING WEIGHT	N° FANS
ENRF 200	2465 kg	3130 kg	5
ENRF 230	2695 kg	3365 kg	5
ENRF 280	2820 kg	3510 kg	6
ENRF 340	2920 kg	3625 kg	6
ENRF 370	2980 kg	3700 kg	6

Scale-Scale	Date-Date	24/01/14	Dis.to-Drawn	B. C.	N°Pezzi
Peso-Weight Kg.	Material-Materials				
Denominazione-Denomination WATER CHILLER mod. ENRF 200+370/CS.ST.T.WP					
Particolare-Detail OVERALL DIMENSIONS - LIFT INSTRUCTIONS					
REFRIGERANT R410a					

HITEMA[®]
DIS.-DRAWN. DIM-ENRF-230ST0100
Rev. 02 - B.C. - 12/01/17
PROGRAM.N.

Copyright - Nachdruck verboten

CSE models 030, 038, 045

LEGEND

HPG	High pressure gauge (Opt)
LPG	Low pressure gauge
MW	Water pressure gauge
RM	Manual water filling cap
SFA	Manual air vent
VSC	Water drain valve
ATV	Rubber type antivibrant mounting (Opt)

LIFTING AND CARRIAGE PRECAUTIONS

- Check the weight on the CE label to select appropriate lift equipment .
- Before lifting the unit make sure that the external panel is firmly fixed in place.
- To use only lifting points provided.
- The chains or slings must be of equal length.
- To use a spread-bar to avoid damage to the unit.
- The movement must be performed with caution and avoid abrupt movements.
- Never move the unit on rollers.

MAKE STRAIGHT PIPING FOR AIR FOR EACH FAN WITH SAME DIMENSION OF FAN DELIVERY AND WITH A LENGTH BIGGER THAN 1,2 METERS

MOD.	EMPTY WEIGHT	OPERATING WEIGHT
CSE 030	445 kg	720 kg
CSE 038	465 kg	740 kg
CSE 045	495 kg	770 kg

Scale-Scale	Date-Date	07/04/15	Dis.to-Drawn	M. M.	N°Pezzi
Peso-Weight Kg.	Material-Materials				
Denominazione-Denomination WATER CHILLERS mod. CSE.030+045					
Particolare-Detail Overall dimension - Lift Instruction					
REFRIGERANT R410a					

HITEMA[®]
DIS.-DRAWN. DIM-CSE-030ST01
Rev. 02-M.M.-17/01/17
PROGRAM.N.

Copyright - Nachdruck verboten

SPREAD-BAR

HPG

LPG

WATER INLET 2" BSP F

WATER OUTLET 2" BSP F

RM / SFA 1" BSP F

MW

VSC 1/2" BSP

ELECTRICAL FEED

MAKE STRAIGHT PIPING FOR AIR FOR EACH FAN WITH SAME DIMENSION OF FAN DELIVERY AND WITH A LENGTH BIGGER THAN 1,2 METERS

SPREAD-BAR

1900

1853

1100

80

930

1090

N°4 HOLES Ø20 FOR THE FLOOR MOUNTED ATV (Opt)

2220

65

875

1030

755

164

1884

164

2210

1/2" BSP

1000

1500

350

395

350

1000

204

342

288

342

288

342

1000

SAFETY PIN (SAFETY DEVICE)

PIPE Ø48 Thk. 5mm min.

DISC OF CLOSING

MAX 180

DETAIL B

LEGEND

HPG	High pressure gauge
LPG	Low pressure gauge
MW	Water pressure gauge
RM	Manual water filling cap
SFA	Manual air vent
VSC	Water drain valve
ATV	Rubber type antivibrant mounting (Opt)

LIFTING AND CARRIAGE PRECAUTIONS

- Check the weight on the CE label to select appropriate lift equipment .
- Before lifting the unit make sure that the external panel is firmly fixed in place.
- To use only lifting points provided.
- The chains or slings must be of equal length.
- To use a spread-bar to avoid damage to the unit.
- The movement must be performed with caution and avoid abrupt movements.
- Never move the unit on rollers.

MOD.	EMPTY WEIGHT	OPERATING WEIGHT
CSE 061	770 kg	1190 kg
CSE 075	800 kg	1220 kg

Scale-Scale	Data-Date	Dis.to-Drawn	N°Pezzi
Peso-Weight Kg.	29/05/15	M. M.	
Material-Materials			
Denominazione-Denomination			
WATER CHILLERS mod. CSE.061+075			
Particolare-Detail			
Overall dimension - Lift instruction			
REFRIGERANT R410a			

HITEMA

DIS-DRAW N. DIM-CSE-061ST01

Rev. 01-M.M.-17/01/17

PROGRAMM.

Copyright - Nachdruck verboten

CSE models 061, 075

SPREAD-BAR

HPG

LPG

WATER INLET 2" BSP F

WATER OUTLET 2" BSP F

RM / SFA 1" BSP F

MW

VSC 1/2" BSP

ELECTRICAL FEED

MAKE STRAIGHT PIPING FOR AIR FOR EACH FAN WITH SAME DIMENSION OF FAN DELIVERY AND WITH A LENGTH BIGGER THAN 2 METERS

SPREAD-BAR

2350

2312

10

1100

80

930

1090

N°4 HOLES Ø20 FOR THE FLOOR MOUNTED ATV (Opt)

2220

65

755

1480

755

164

1884

164

2210

1/2" BSP

1000

1500

326

567

213

1000

372

478

503

478

386

1000

SAFETY PIN (SAFETY DEVICE)

PIPE Ø48 Thk. 5mm min.

DISC OF CLOSING

MAX 180

DETAIL B

LEGEND

HPG	High pressure gauge
LPG	Low pressure gauge
MW	Water pressure gauge
RM	Manual water filling cap
SFA	Manual air vent
VSC	Water drain valve
ATV	Rubber type antivibrant mounting (Opt)

LIFTING AND CARRIAGE PRECAUTIONS

- Check the weight on the CE label to select appropriate lift equipment .
- Before lifting the unit make sure that the external panel is firmly fixed in place.
- To use only lifting points provided.
- The chains or slings must be of equal length.
- To use a spread-bar to avoid damage to the unit.
- The movement must be performed with caution and avoid abrupt movements.
- Never move the unit on rollers.

MOD.	EMPTY WEIGHT	OPERATING WEIGHT
CSE.100	990 kg	1410 kg

Scale-Scale	Data-Date	Dis.to-Drawn	N°Pezzi
Peso-Weight Kg.	20/07/15	M. M.	
Material-Materials			
Denominazione-Denomination			
WATER CHILLERS mod. CSE 100			
Particolare-Detail			
Overall dimension - Lift instruction			
REFRIGERANT R410a			

HITEMA

DIS-DRAW N. DIM-CSE-100ST01

Rev. 01-M.M.-17/01/17

PROGRAMM.

Copyright - Nachdruck verboten

CSE model 100

CSE models 130, 160

LEGEND

HPG	High pressure gauge
LPG	Low pressure gauge
MW	Water pressure gauge
RM	Manual water filling cap
SFAS	Tank manual air vent
SFA	Manual air vent
VSCS	Tank water drain valve
ATV	Rubber type antivibrant mounting (Opt)

LIFTING AND CARRIAGE PRECAUTIONS

- Check the weight on the CE label to select appropriate lift equipment .
- Before lifting the unit make sure that the external panel is firmly fixed in place.
- To use only lifting points provided.
- The chains or slings must be of equal length.
- To use a spread-bar to avoid damage to the unit.
- The movement must be performed with caution and avoid abrupt movements.
- Never move the unit on rollers.
- Never lift the unit using a fork-lift.

Scale- Scale	Date- Date	Dis. to- Drawn	N° Pezzi
Peso- Weight Kg.	16/07/15	B.P.	
Material- Materials			
Denominazione- Denomination	WATER CHILLERS mod. CSE.130-160/CS.ST.T.WP.		
Particolare- Detail	Overall dimension - Lift Instruction		
REFRIGERANT R410a			

MOD.	EMPTY WEIGHT	OPERATING WEIGHT
CSE.130	1315 kg	1740 kg
CSE.160	1365 kg	1800 kg

HITEMA
DIS.-DRAW N. DIM-CSE-130ST01
Rev. 01 - B.C. - 13/01/17
PROGRAMN.

Copyright - Nachdruck verboten

CSE models 185

LEGEND

HPG	High pressure gauge
LPG	Low pressure gauge
MW	Water pressure gauge
RM	Manual water filling cap
SFAS	Tank manual air vent
SFA	Manual air vent
VSCS	Tank water drain valve
ATV	Rubber type antivibrant mounting (Opt)

LIFTING AND CARRIAGE PRECAUTIONS

- Check the weight on the CE label to select appropriate lift equipment .
- Before lifting the unit make sure that the external panel is firmly fixed in place.
- To use only lifting points provided.
- The chains or slings must be of equal length.
- To use a spread-bar to avoid damage to the unit.
- The movement must be performed with caution and avoid abrupt movements.
- Never move the unit on rollers.
- Never lift the unit using a fork-lift.

Scale- Scale	Date- Date	Dis. to- Drawn	N° Pezzi
Peso- Weight Kg.	08/02/17	B.C.	
Material- Materials			
Denominazione- Denomination	WATER CHILLERS mod. CSE.185/CS.ST.T.WP.		
Particolare- Detail	Overall dimension - Lift Instruction		
REFRIGERANT R410a			

MOD.	EMPTY WEIGHT	OPERATING WEIGHT
CSE.185	1730 kg	2170 kg

HITEMA
DIS.-DRAW N. DIM-CSE-185ST01
Rev. 00
PROGRAMN.

Copyright - Nachdruck verboten

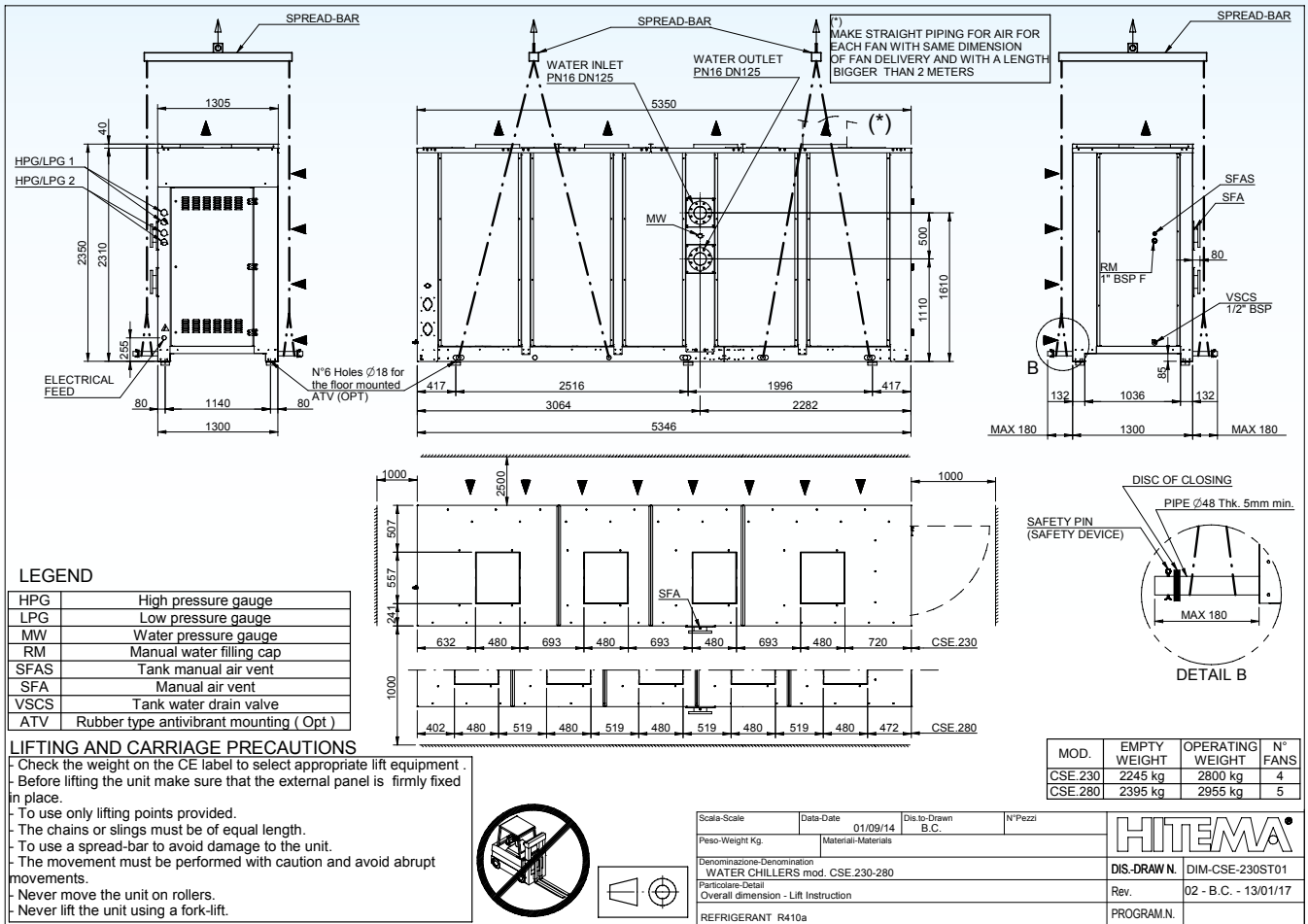

CSE models 230, 280

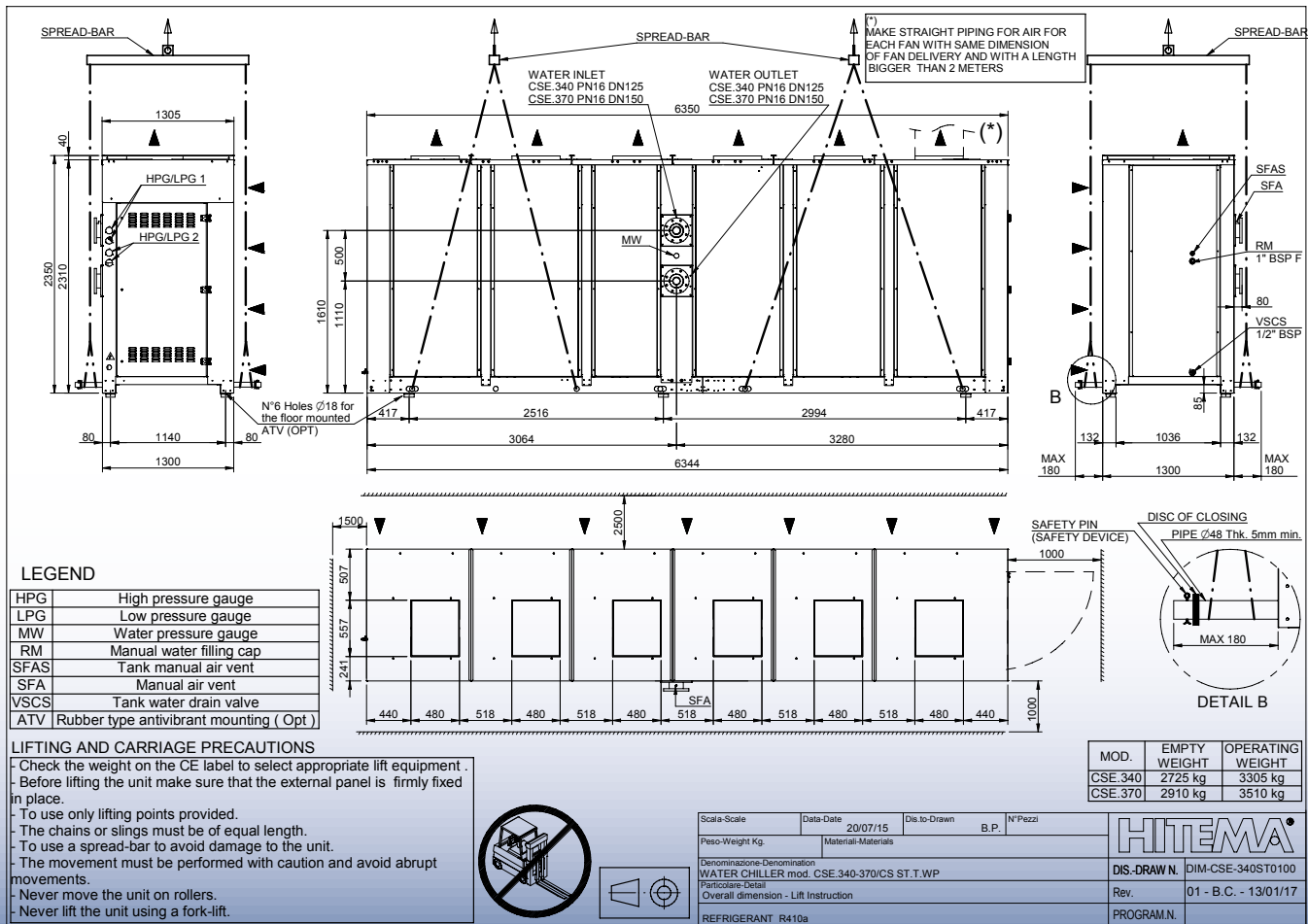

CSE models 340, 370

19 Installation Guide

To enable the operations of control, maintenance and repair, the unit must be accessible on each side. Each installation must have the perimeter spaces that guarantee both maintenance and spaces suitable for air circulation to the condenser coil (please refer at point n.18 "dimensional drawings"). A minimum lifting distance as indicated in the figure is recommended. Also ensure the free movement of air, without obstacles, both in lifting and in delivery.

19 Zugänglichkeit

Um die Kontrolle, Wartung und Reparatur zu ermöglichen, hat das Gerät auf beiden Seiten zugänglich zu sein. Jede Installation hat über die Perimeter-Freiräume zu verfügen, durch die die Wartung und die Freiräume für Luftzirkulation zur Kühleispeule sichergestellt werden (bitte unter Punkt 18 "Maßzeichnungen" zu Rate ziehen). Ein Mindest-Hubweg so wie in der Abbildung wird empfohlen. Zudem ist ein freier Luftzug ohne Hindernisse sicherzustellen, sowohl beim Anheben und bei Lieferung.



ATTENTION!



The base must be stable, able to support the weight of the unit, perfectly horizontal in the area of placement on the ground of the machine and must be positioned in such a way as to prevent the stagnation of water. It is advisable to interpose between the machine and the suitable rubber base anti-vibration devices or a neoprene rubber sheet.

ACHTUNG!

Die Unterlage muss das Gewicht der Anlage tragen können, stabil und in dem Bereich waagrecht sein, in dem die Maschine auf den Boden gestellt wird, außerdem muss sie so positioniert werden, dass sich kein Wasser darunter oder darauf sammeln kann. Es ist ratsam, zwischen der Maschine und der passenden Gummi-Unterlage vibrationsdämmende Vorrichtungen oder eine Neopren-Gummimatte zu legen.

20 Unit packing

- for mod. 001÷055 full cardboard protection and pallet or wooden spacers on bottom (see the following reported picture A).
- for mod. 061÷480 vertical cardboard protection on unit corners, nylon covering and wooden spacers on bottom (B).

20 Verpackung der Einheit

- für Mod. 001 ÷ 055 Kartonschutz und Palette oder Platzhalter aus Holz auf der Unterseite (siehe im Folgenden für bild A).
- für Mod. 061 ÷ 480 vertikaler Kartonschutz an den Ecken des Gerätes, Nylonüberzug und Platzhalter aus Holz auf der Unterseite (B).



Work with our software



Choose the best solution to cool your business with our **SELECTION SOFTWARE**

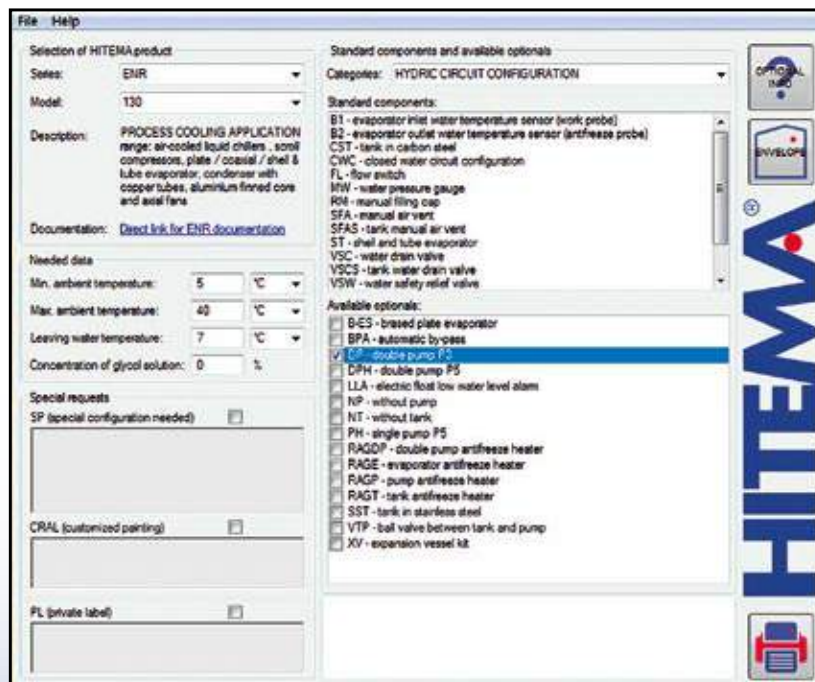

Choose amongst more than 100 options to customize your chiller with our **HITEMA CONFIGURATOR**

The complete Hitema range of products
Our focus is keeping Customers' business
running 100% efficiently

Die komplette Hitema produktpalette
Unser fokus liegt darauf, die geschäfte
unserer Kunden zu 100% effizient und
zuverlässig zu gestalten

PROCESS COOLING APPLICATION
series (R410A, R32):

- ENR series, air-cooled liquid chillers with axial fans. Cooling range 1,6÷410kW
- ENRF series, free-cooling liquid chillers with axial fans. Cooling range 23÷355kW
- CSE series, air-cooled liquid chillers with centrifugal fans. Cooling range 30÷377kW
- ENW series, water-cooled liquid chillers. Cooling range 3,8÷476kW



PROZESSKÜHLUNG ANWENDUNGSSERIE
(R410A, R32):

- ENR, luftgekühlte Flüssigkeitsabkühler mit Axialventilatoren. Kühlbereich 1,6÷410kW
- ENRF, freikühlende Flüssigkeitsabkühler mit Axialventilatoren. Kühlbereich 23÷355kW
- CSE, luftgekühlte Flüssigkeitsabkühler mit Radialventilatoren. Kühlbereich 30÷377kW
- ENW, wassergekühlten Flüssigkeitsabkühler. Kühlbereich, 3,8÷476kW

AIR CONDITIONING COOLING
APPLICATION series (R410A, R32):

- CFT series, air-cooled liquid chillers with axial fans. Cooling range 7,9÷410kW
- HFT series, reversible air to water heat pump for applications up to 0°C ambient temperature. Heating range 25÷350kW. Cooling range 31÷410kW



SERIE ZU KLIMAANLAGE
KÜHLUNGSANWENDUNGEN (R410A, R32):

- CFT, luftgekühlte Flüssigkeitsabkühler mit Axialventilatoren. Kühlbereich 7,9÷410kW
- HFT luftgekühlte, reversible Luft/Wasser-Wärmepumpe für Anwendungen bis 0 °C Umgebungstemperatur. Heizfläche 25÷350kW. Kühlbereich 31÷410kW

MULTI SCROLL
series (R410A, R32):

- SBS series, air-cooled liquid chillers with axial fans. Cooling range 98÷1.230kW
- SBSF series, free-cooling liquid chillers with axial fans. Cooling range 94÷1.033kW



SERIE MULTI SCROLL
(R410A, R32):

- SBS, luftgekühlte Flüssigkeitsabkühler mit Axialventilatoren. Kühlbereich 98÷1.230kW
- SBSF, freikühlende Flüssigkeitsabkühler mit Axialventilatoren. Kühlbereich 94÷1.033kW

COOLING BIG EVOLUTION
series (R134a, R513A or R1234ze):

- NOVA series, air-cooled liquid chillers with axial fans. Cooling range 223÷1.498kW
- NOVAF series, free-cooling liquid chillers with axial fans. Cooling range 237÷1.330kW



KÜHLUNGSSERIE BIG EVOLUTION
(R134a, R513A or R1234ze):

- NOVA, luftgekühlte Flüssigkeitsabkühler mit Axialventilatoren. Kühlbereich 223÷1.498kW
- NOVAF, freikühlende Flüssigkeitsabkühler mit Axialventilatoren. Kühlbereich 237÷1.330kW

COOLING BIG EVOLUTION
series (R134a, R513A or R1234ze):

- ISV series, air-cooled liquid chillers with axial fans and inverter driven screw compressors. Cooling range 224÷955kW
- ISVF series, free-cooling liquid chillers with axial fans and inverter driven screw compressors. Cooling range 224÷955kW



KÜHLUNGSSERIE BIG EVOLUTION
(R134a, R513A, R1234ze):

- ITC, luftgekühlte Flüssigkeitsabkühler mit Axialventilatoren und inverterbetriebene Schraubenkompressoren. Kühlbereich 224÷955kW
- ITF, luftgekühlte Flüssigkeitsabkühler mit Axialventilatoren und inverterbetriebene Schraubenkompressoren. Kühlbereich 224÷955kW

The complete Hitema range of products
Our focus is keeping Customers' business running 100% efficiently

Die komplette Hitema produktpalette
Unser fokus liegt darauf, die geschäfte unserer Kunden zu 100% effizient und zuverlässig zu gestalten

COOLING BIG EVOLUTION series (R134a, R513A, R1234ze):

- EWB series, water-cooled liquid chillers. Cooling range 291÷2.240kW
- EWBH series, water-cooled liquid heat pumps not reversible. Heating range 330÷2490kW
- CWB series, condenser less liquid chillers. Cooling range 270÷2004kW



KÜHLUNGSSERIE BIG EVOLUTION (R134a, R513A, R1234ze):

- EWB, wassergekühlten Flüssigkeitskühler. Kühlbereich 291÷2.240kW
- EWBH, wassergekühlte Flüssigkeitswärmepumpen nicht reversibel. Heizbereich 330÷2.490kW
- CWB, kondensatorlose Flüssigkeitskühler. Kühlbereich 270÷2.004kW

REVERSIBLE HEAT PUMP series (R410A, R290):

- SBS- HP series, reversible air to water heat pump for low ambient temperature application. Heating range 61÷105 kW. Cooling range 52÷90 kW



REVERSIBLE WÄRMEPUMPE (R410A, R290):

- SBS-HP, reversible Luft / Wasser-Wärmepumpe für Anwendungen mit geringer Umgebungstemperatur. Heizfläche 61÷105 kW. Kühlbereich 52÷90 kW

COOLING APPLICATION series (R290):

- PRP R290 series, air-cooled liquid chillers with axial fans. Cooling range 25÷820kW



SERIE ZU KÜHLUNGSANWENDUNGEN (R290):

- PRP R290, luftgekühlte Flüssigkeitsabkühler mit Axialventilatoren. Kühlbereich 25÷820kW

TURBOCOR series (R134a or R1234ze):

- AHA series, air-cooled liquid chillers with EC axial fans and Danfoss TurboCor oil free compressors. Cooling range 245÷1.400kW
- AHF series, free-cooling liquid chillers with EC axial fans and Danfoss TurboCor oil free compressors. Cooling range 245÷1.100kW



SERIE TURBOCOR (R134a oder R1234ze):

- AHA, luftgekühlte Flüssigkeitskühler mit EC-Axialventilatoren und Danfoss TurboCor ölfreie Kompressoren. Kälteleistung 245÷1.400kW
- AHF, freikühlende Flüssigkeitskühler mit EC-Axialventilatoren und Danfoss TurboCor ölfreie Kompressoren. Kälteleistung 245÷1.100kW

TURBOCOR series (R134a or R1234ze):

- AHW series, water-cooled liquid chillers and Danfoss TurboCor oil free compressors. Cooling range 260÷3.500kW



SERIE TURBOCOR (R134a oder R1234ze):

- AHW, wassergekühlte Flüssigkeitskühler und Danfoss TurboCor ölfreie Kompressoren. Kälteleistung 260÷3.500kW

Worldwide installations by Hitema

Weltweite Umsetzung durch Hitema



* Chiller installed in UK, 1070 kW

Chiller with Turbocor compressors, installed in Spain, 780 kW



* Chiller installed in Dusseldorf, Germany, 820 kW

Industrial application, installed in Spain with Turbocor compressors, 840kW



* Propane R290, installed in Germany, 270kW @ +7°C LWT

Chillers installed in France, total cooling capacity 1155 kw



* Seismic test, installed in Canada, 300 kW

Free-cooling chiller, 1240kW *
 460/3/60 UL, ASME evaporator
 Installed in USA for Data Center



* Water-cooled chiller with inverter driven screw compressors installed in UK for chemical application. 600kW @ -2°C LWT

Freecooling liquid chiller with double refrigerating circuit, double hydraulic circuit and double power supply installed in Russia. 522kW @ +3°C LWT





* Water-Cooled liquid chiller with marine condensers installed in UK. 765kW @ +7°C LWT

Chiller with double power supply *
installed in Russia
522kW @ 3°C LWT



* Chiller for high ambient temperature (55 °C) installed in UAE

Chiller with customized design *
installed in UK
236kW @ 10°C LWT



* Condenserless chiller with small footprint installed in USA
308kW @ 7,2°C LWT

Freecooling chiller for aggressive atmosphere installed in Canada
160kW @ 18,3°C LWT



* Modular reversible air to water heat pump installed in Switzerland for space heating/cooling. 105kW @ +45°C LWT

Water-cooled chiller with inverter screw compressors installed in UK
600kW @ -2°C LWT



* Condenserless chiller with tank and double pump installed in USA
145kW @ 7°C LWT

Freecooling chiller with special voltage installed in USA
319kW @ 4,4°C LWT



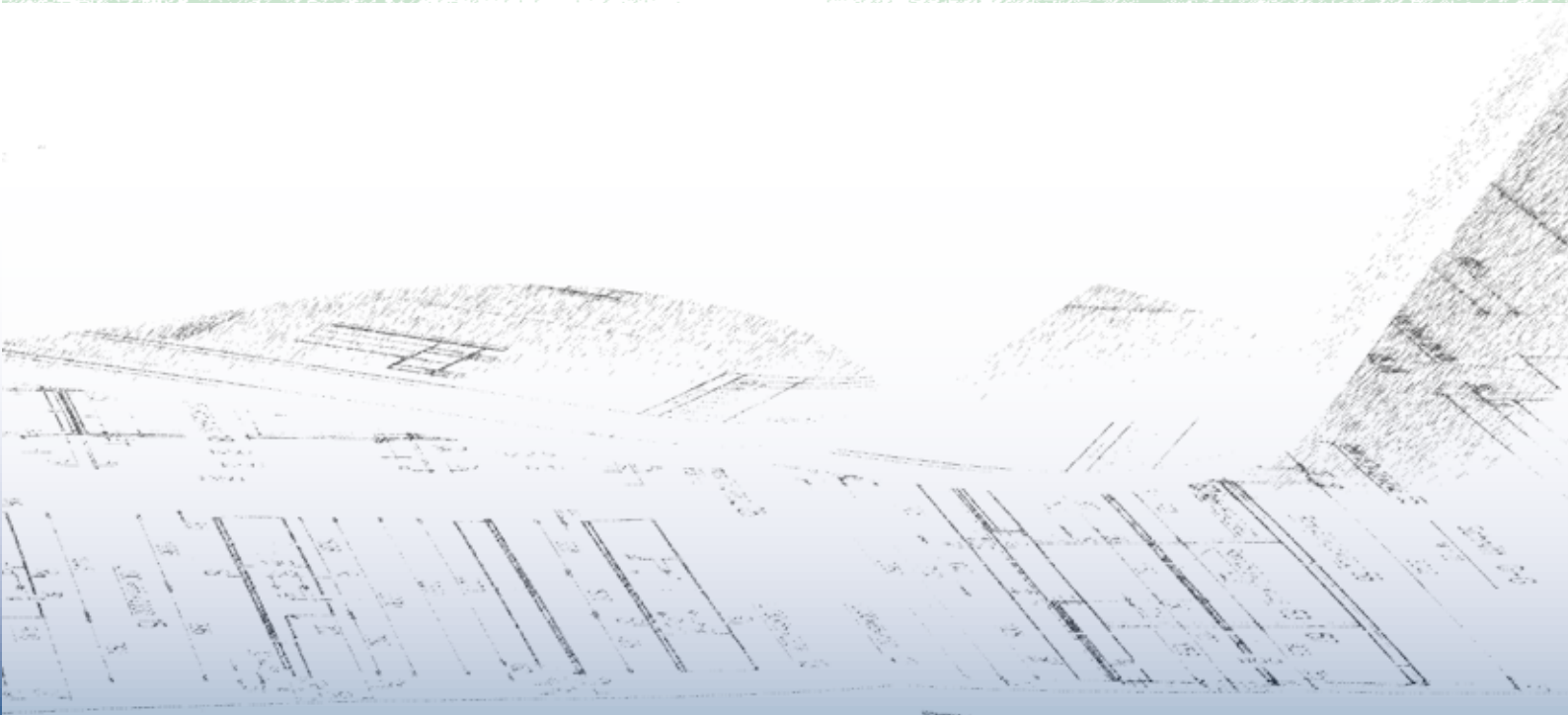



Bovolenta, Padua facilities - Italy

HITEMA[®]
international

HITEMA[®] S.r.l.
Via Mons. Giulio Babolin, 14
Z.I. SAN GABRIELE - 35024 BOVOLENTA
PADOVA - ITALY
C.F. e P.I. IT02349000279

Tel. +39 (0) 49.5386344 12 lines r.a.
Fax +39 (0) 49.5386300

info@hitema.it
Managing Director / *Direkten Kontakt:*
burbam@hitema.it



For details of our range of products & services, please visit
Details über unser Service-Angebot finden Sie unter

hitema.com

Series: ENR, ENRF, CSE	Cod: TDS-SCLS01-REV04	Checked by:
September 2018	Updated: TDS-SCLS01-REV03	✓ M. Burba