



JOHN KING

Conveyor Chains & Sprockets Worldwide

Timber Processing and Paper and Pulp Industry Chains.



Material Processing Solutions Since 1926.

Rev.14.09.2022
This design is the exclusive property of JOHN KING CHAIN Ltd
and copyright protected under the Designs and Patents Act 1988



Get in Touch With Us

John King Chains Limited
Lancaster Business Park, Sherburn-in-Elmet, LS25 6NS, UK
ENGLAND

or Call Us by Phone

+44 1977 681 910

From Survey to Drawing to Production to Installation

Your integrated supply partner.

In the aggressive environment of timber production there is an ongoing requirement for refurbishment and replacement of plant and equipment in all areas of the process. John King Group is a combined business uniquely equipped to serve the industry with a full spectrum of essential engineering services to ensure customers equipment is in the best condition in order to maintain essential processes.



Inspection, Survey and Consultation.

As part of the supply package qualified engineers will come to site and inspect items of plant and equipment to establish and report on the condition. Subsequent consultation generally includes means for improvement such as: materials employed, design, construction, implementation, additional operation and maintenance advice.



Industry Leading Steel Processors.

With decades of in-house experience in metal processing and fabrication, we use the latest technology and techniques to deliver quality, bespoke solutions for our clients. From laser cutting to punching, bending and welding our skilled team will deliver a high quality solution that is both on time and in budget.

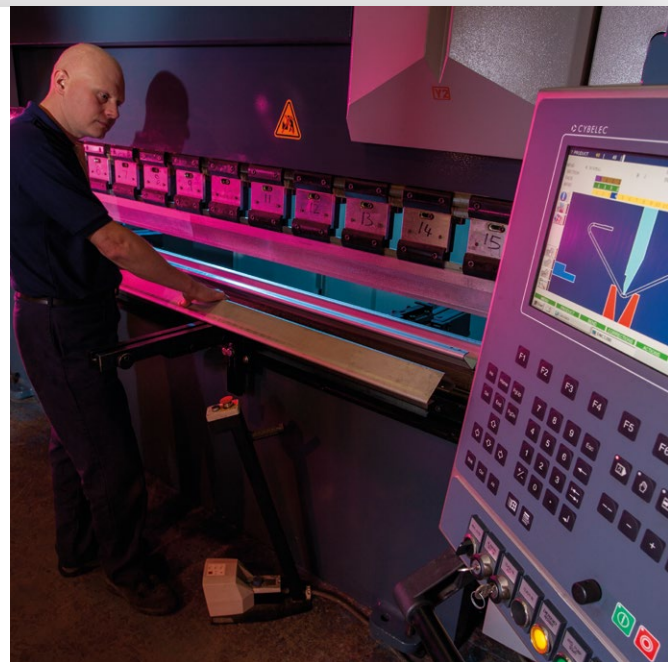



Design and Drawing Service.

Design and technical drawing is part of our service. We create the technical drawing directly from our site survey or work with you to create a full design brief to meet your fabrication needs. We will support you in developing and improving the plant and equipment.



Fully Integrated Installation.

Our site service team comprising experienced mechanical fitters and fabricators will install all types of mechanical handling equipment, metal fabrications and equipment at your premises in the agreed timescale with a high degree of competence whilst operating under strict safety protocol.

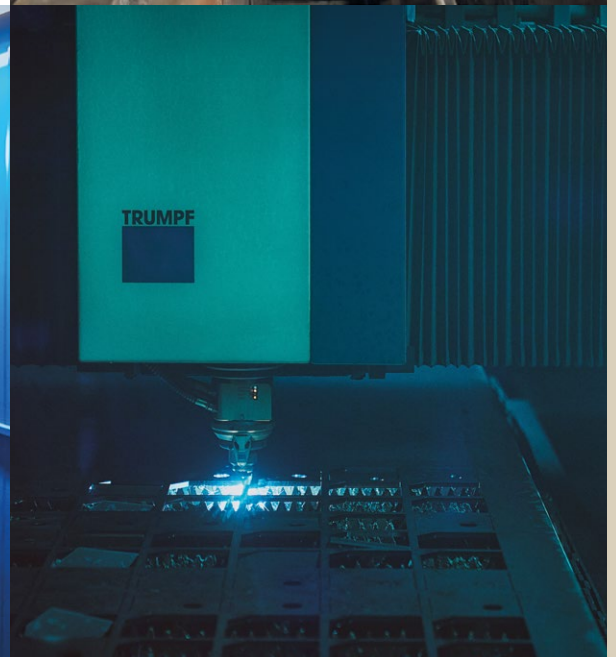
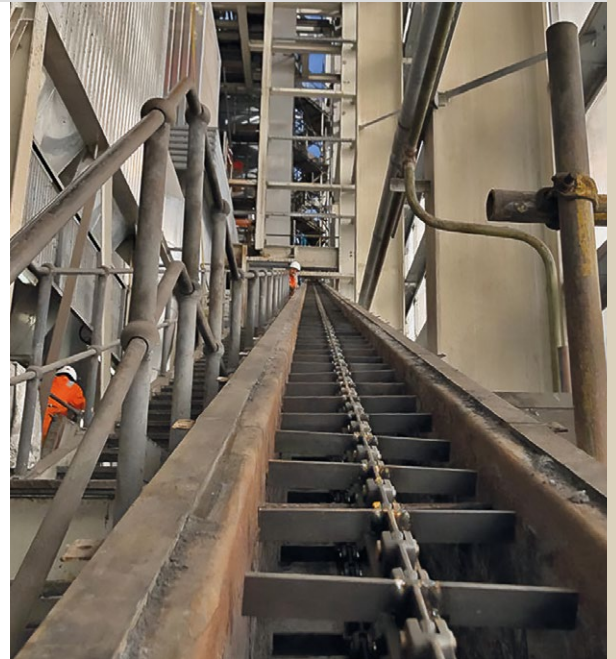



The Undisputed Kings of Laser Profiling and Fabrication.

FROM SURVEY TO DRAWING TO PRODUCTION – THE ONE STOP SHOP

John King Laser was established in 2007 primarily to service the mechanical handling division. It was well understood that the available capacity surpassed that of in-house requirements and the business model from the outset was to sell laser cut, formed and fabricated parts to a wide variety of customers producing a wide range of machinery and equipment.

More recently John King Laser has been able to support the groups site service division where bespoke fabrications have been required.

The laser division has remained autonomous from the start whilst critically benefitting as part of the Group structure in investing in new technology to give the division a distinct advantage in efficiency and quality of products produced. The recent installation of the newest and probably best laser capacity in the country is testament to this.

Manufacturing Capabilities.

The 2020s business is a lean enterprise working from a modern manufacturing facility employing best production techniques including fibre laser technology, plasma for thicker material sections, CNC machining and robotics. Group structure provides the internal resource to implement production management systems that ensures highest quality, consistent and competitive products produced in a safe environment. All manufacturing is conducted within the dictates of ISO 9001 to the latest 2015 standard to ensure quality objectives are monitored and maintained.

LASER CUTTING CAPABILITIES

- Mild and carbon steel up to 25 mm.
- Stainless steel up to 15 mm.
- Aluminium up to 12 mm.

FLAME CUTTING AND PLASMA CUTTING CAPABILITIES

- Machine bed size of 4 m x 2.5 m.
- Flame cutting up to 110 mm.
- Plasma cutting up to 30 mm.

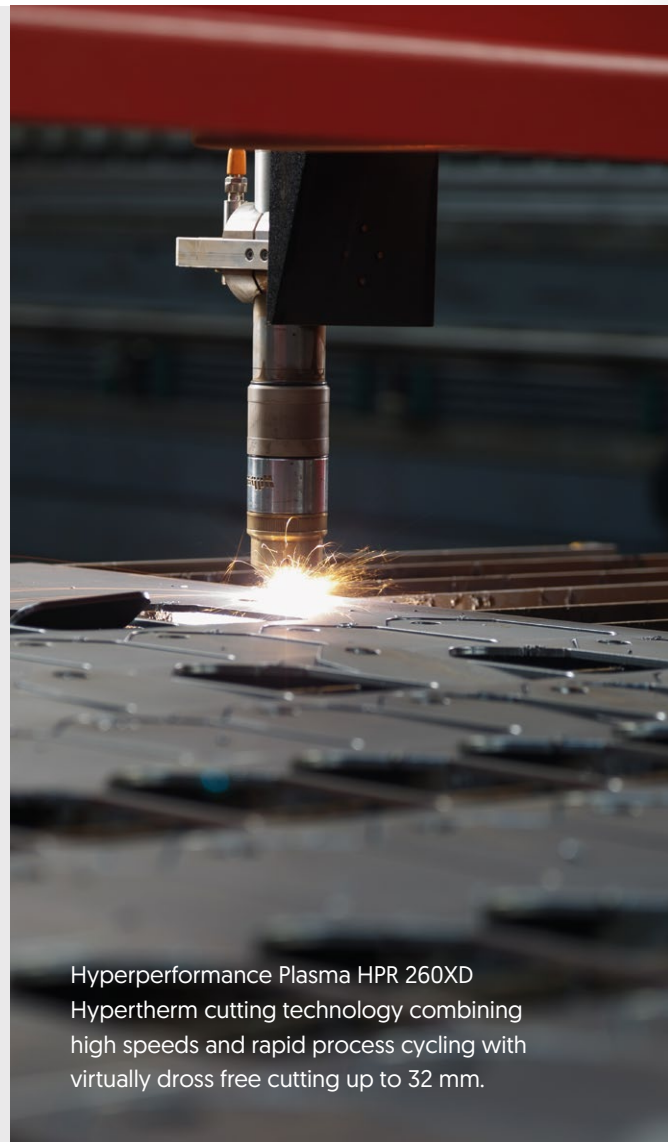

Hyperperformance Plasma HPR 260XD
Hypertherm cutting technology combining high speeds and rapid process cycling with virtually dross free cutting up to 32 mm.



Trulaser 3040 Fibre laser with increased 4000 x 2000 bed size including integrated lift master and plate storage tower for unrivalled efficiency in parts production.

Press Technology.

In support of our impressive range of flatbed processing capabilities we operate CNC Synchro press brake machines capable of pressing parts with capacities up to and including 220 tons and 4000 mm in length. With smaller machines with 2000 mm gap and 100 mm stroke for smaller parts in higher volume production.



Welding and Fabrication.

Our welding and fabrication capacity includes a high level of skill in both internal and external projects. This enables John King's laser and fabrication division to offer an all-encompassing manufacturing service. The site service division will thereafter take charge of the installation as required.

Ash hopper during fabrication as a direct replacement to an existing unit.

Replacement conveyor sections reproduced on a like for like basis.

A new precipitator dust conveyor during manufacture and prior to entering the paint shop.

Chute sections to make up a full arrangement ready for site service installation.





Site Services The Complete Supply Package.

Bulk handling experts you can rely on.

The **John King Site Service Division** employ a highly skilled team of engineers solely dedicated to the **service and maintenance of bulk material handling equipment** which includes – installing, servicing and maintaining all aspects of mechanical handling equipment and related plant and machinery.

The market demands **high quality chains** and **expert installation**. **John King Chains** uniquely **offer both**. Make the most of it.

- **Secure optimum reliability of your equipment** through **best quality chains** and **conveyor component spares**.
- Take advantage of **the quickest deliveries of conveyor spares** of any manufacturer in the market.
- Let **the conveyor specialist** look after your equipment to ensure **optimum performance** and **service life**.
- Allow us to highlight technical improvement **to enhance performance of your existing equipment**.
- Enter into **a professional partnership** to develop a service strategy tailored to suit your needs.

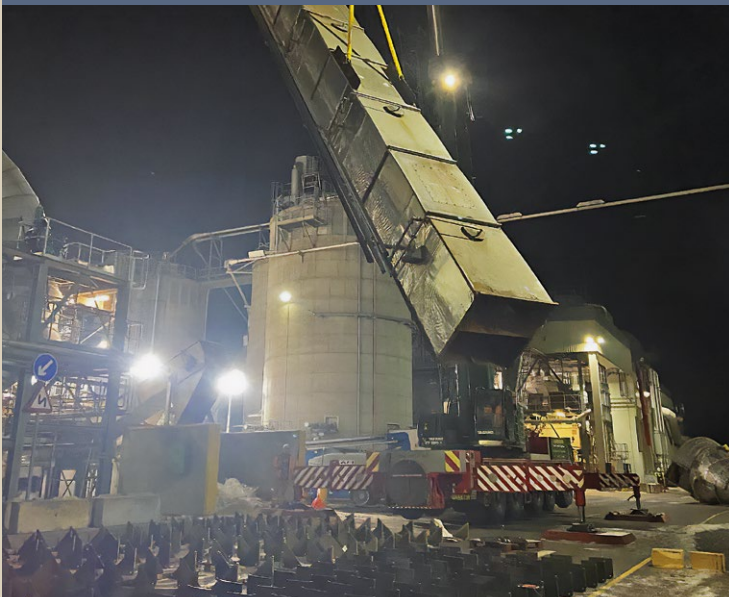



Site Services Scope of Supply.

- **Inspection and maintenance** of all mechanical handling equipment by specialist engineers
- **Trouble shooting** and problem solving within mechanical handling equipment.
- **Supply of high quality conveyor chain** and related conveyor spares.
- **Specialist in supply of heat resistant components.**
- **In house laboratory** for material and heat treatment analysis with full metallurgical support.
- **Manufacture and installation of all types of fabrications** from pre-hardened plate, stainless steels or standard materials.
- **Replacement of sections or full conveyors and elevators** including manufacture and installation.
- **Design and construction of complete bulk handling equipment** including installation service.
- **Repair and maintenance** of all related plant and equipment.

Safety at Work.

We are committed to providing and maintaining a healthy and safe environment for all employees and to protect the safety of contractors, customers, visitors and all other persons affected by our operations.

This is achieved by assessing all significant risks, designing safe systems of work and eliminating hazards where reasonably practicable. **This being encapsulated within the company HSE policy and enshrined in the everyday culture of our business.**

Offset Sidebar Welded Steel Chains.



John King welded steel chains have become North America's preferred choice in many materials handling applications. The simple and robust construction offers a superior method of conveying most materials. These chains employ an offset side plate and circumferentially welded bush. The pin is a high interference fit into the plate retained with a heavy hot rivet or cotter. The standard KING specification is updated over the industry standard with the proven IBR designation. This incorporates standard through hardening, but with additional surface induction hardening of both the bush and pin. The end result is a chain offering maximum toughness and high abrasion resistance for optimum performance in high duty applications.

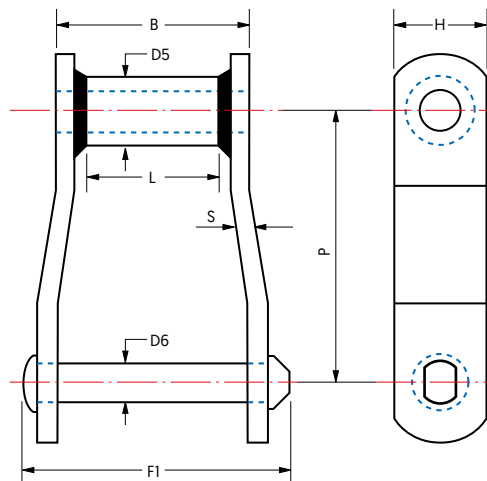

Offset Sidebar Welded Steel Chains

Chain Number	Pitch	Bushings	Rivets	Over-All Pin & Cotter	Between Sidebars	Length of Bearing	Sidebars		Breaking Load	Average Weight
		Outside Diameter	Diameter				Thickness	Height		
	P	D5	D6	F1	L	B	S	H	lbs	lbs/ft
	inches									
WH78/R	2.609	0.84	0.50	3.00	1.00	2.00	0.25	1.25	33,000	4.30
WH82/R	3.075	1.00	0.56	3.38	1.13	2.25	0.25	1.25	36,000	4.70
WH124/R	4.000	1.25	0.75	4.25	1.50	2.75	0.38	1.50	57,000	7.80
WH111/R	4.760	1.25	0.75	4.81	1.75	3.38	0.38	1.75	60,000	8.60
WH110/R	6.000	1.25	0.75	4.00	1.88	3.00	0.38	1.50	50,500	7.00
WH106/R	6.000	1.25	0.75	4.25	1.50	2.75	0.38	1.50	60,000	6.20
WH132/R	6.050	1.75	1.00	6.38	2.75	4.41	0.50	2.00	122,000	14.10
WH150/R	6.050	1.75	1.00	6.50	2.75	4.41	0.50	2.50	122,000	16.30
WH155/R	6.050	1.75	1.13	6.41	2.75	4.44	0.56	2.50	175,000	19.00
WH157/R	6.050	1.75	1.13	6.75	2.75	4.63	0.63	2.50	175,000	20.00
WH159/R	6.125	2.00	1.25	6.75	2.75	4.63	0.63	3.00	210,000	26.00
WH200/R	6.125	2.00	1.25	6.75	2.75	4.63	0.63	2.50	190,000	22.10

Add IBR for fully heat treated parts plus induction hardened barrels and rivets. Suffix R denotes riveted pin style.

King WHM Series Equivalent Welded Steel Chains



John King offer a unique range of welded steel chains dimensionally equivalent to M Series bush chains according to DIN8167. The chain offers all the benefits of the “offset” sidebar welded construction and can be offered as a direct replacement in existing conveyors and operate on same sprockets. This allows the user a unique opportunity to improve reliability and service life without major alteration.

Key Features:

- Direct replacement with Metric standard DIN 8167,
- Increased ultimate tensile strength of up to 65% as compared to standard M series chain,
- Welded bush for increased shock resistance,
- Best specification with all parts through hardened and surface induction hardening on pins and bushes,
- Crank link design as US standard ISO DP6972. A beneficial construction with maintenance advantages,
- Option to induction harden sliding surfaces,
- Grease lubrication can be included if required,
- Ease of maintenance with an option to remove one offset link not two as with straight sidebar chain.

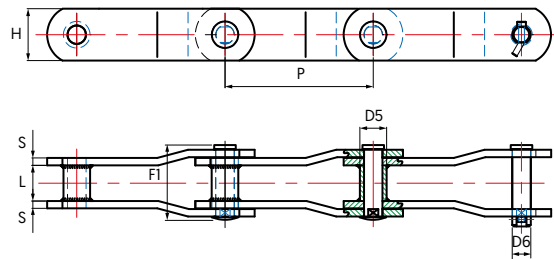

WHM M Series Equivalent Welded Steel Chains

Chain Number	Pitch	Bushings	Pins	Over All Pin	Between Sidebars	Sidebars		Breaking Load	Weight
		Diameter				Thickness	Height		
	P	D5	D6	F1	L	S	H	kN	kg/m
	mm								
WHM160/100/IBR*	100	25	18	72	37	7	50	270	9.5
WHM160/125/IBR*	125	25	18	72	37	7	50	270	8.7
WHM160/160/IBR*	160	25	18	72	37	7	50	270	8.0
WHM224/160/IBR*	160	30	21	84	42	8	60	375	12.8
WHM224/200/IBR*	200	30	21	84	42	8	60	375	11.6
WHM224/250/IBR*	250	30	21	84	42	8	60	375	10.8
WHM315/160/IBR*	160	36	25	97	48	10	70	520	17.8
WHM315/200/IBR*	200	36	25	97	48	10	70	520	16.4
WHM450/200/IBR*	200	42	30	116	56	12	80	700	23.8
WHM450/250/IBR*	250	42	30	116	56	12	80	700	22.1
WHM630/200/IBR*	200	50	36	136	66	14	100	900	38.9
WHM630/250/IBR*	250	50	36	136	66	14	100	900	34.2
WHM630/315/IBR*	315	50	36	136	66	14	100	900	31.7

* IBR represents uprated specification with fully heat-treated components together with induction hardened barrel (bush) and pin.

Heavy Duty Narrow Series Welded Steel Chains.



John King offer a series of welded steel chains specifically designed for high impact and abrading resistance as encountered in timber decks and high duty timber applications. The chain includes fully heat treated chain parts with the addition of induction hardened barrels and rivets. Chains are primarily riveted construction with extra large formed rivet head to ensure maximum integrity.

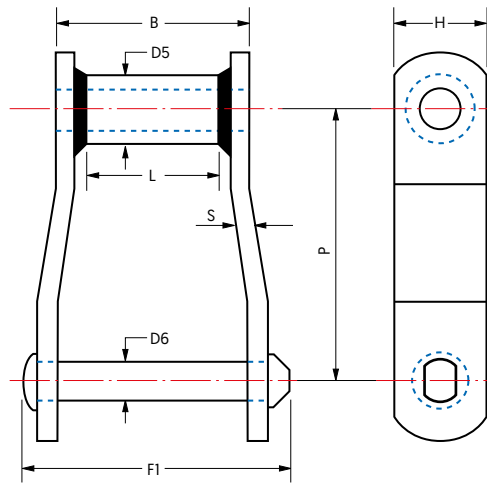

Extra Heavy-Duty Welded Steel Chains										
Chain Number	Pitch	Bushings	Rivets	Over-All Pin & Cotter	Between Sidebars	Length of Bearing	Sidebars		Breaking Load	Average Weight
		Outside Diameter	Diameter				Thickness	Height		
	P	D5	D6	F1	L	B	S	H	lbs	lbs/ft
	inches									
WH78XHD	2.636	1.00	0.56	3.38	1.00	2.00	0.38	1.25	36,000	6.30
WH82XHD	3.075	1.25	0.75	3.75	1.13	2.38	0.38	1.50	57,000	8.50
WH124XHD	4.063	1.63	1.00	4.88	1.50	3.00	0.50	2.00	122,000	14.60
WH106XHD	6.050	1.75	1.00	4.88	1.50	3.00	0.50	2.00	122,000	11.80
WH132XHD	6.050	1.75	1.00	6.75	2.75	4.66	0.63	2.00	122,000	15.30

Wide Series Welded Steel Drag Chains.



John King wide series WDH chains are intended to be used in applications where joint and barrel diameter wear are an issue.

Features include original formed barrel design for complete bearing pin to barrel contact. As with narrow series many material and heat treatment configurations are available. Special attention is paid to pitch control to ensure that in multiple strand applications, such as chipper infeeds or live bottom bins there is accurate matching between the strands.

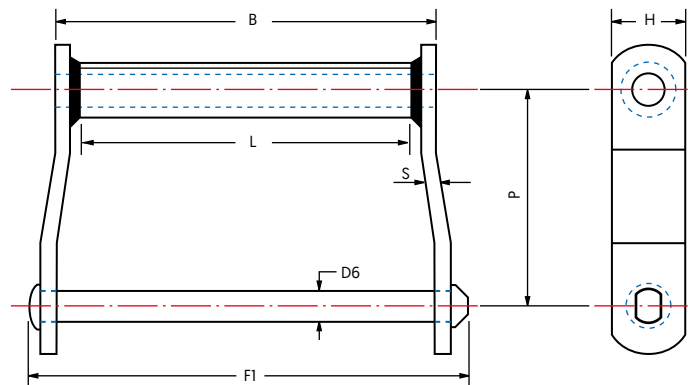

Wide Series Welded Steel Drag Chains									
Chain Number	P	Rivets	Over-All Width	Between Sidebars	Length Of Bearing	Sidebars		Breaking Load	Average Weight
		Diameter				Thickness	Height		
		D6	F1	L	B	S	H		
WDH102	5.00	0.75	9.25	6.38	7.75	0.38	1.50	55,000	11.80
WDH104	6.00	0.75	6.75	4.13	5.38	0.38	1.50	55,000	8.50
WDH110	6.00	0.75	11.75	9.00	10.25	0.38	1.50	55,000	12.00
WDH112	8.00	0.75	11.75	9.00	10.25	0.38	1.50	55,000	10.00
WDH116	8.00	0.75	15.50	13.00	14.13	0.38	1.75	59,000	18.50
WDH118	8.00	0.88	16.63	13.25	14.88	0.50	2.00	79,000	21.00
WDH120	6.00	0.88	12.00	8.75	10.25	0.50	2.00	79,000	20.00
WDH480	8.00	0.88	14.50	11.20	12.75	0.50	2.00	79,000	18.00
WDH580	8.00	1.00	14.63	11.20	12.10	0.50	2.00	108,000	19.40
WDH680	8.00	1.00	15.33	11.20	13.00	0.63	2.00	108,000	21.00

ISO 1977, DIN 8167

M Series Chains.



John King M series has become the most universally encountered European standard of Engineering class chain. It is available in standard bush series, with small “gearing” roller and large carrier roller with or without flange. The fundamental difference between the John King product is that in employing better materials and heat treatment characteristics we achieve higher strength and better wear performance. John Kings approach is always to seek improvements in specifications and or constructions that, where appropriate will enhance product performance.

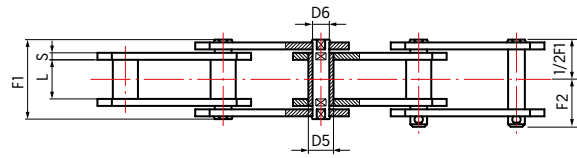
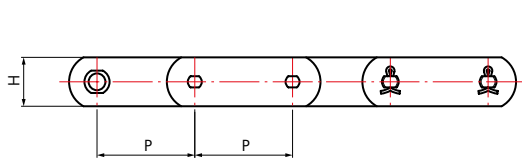

Type A – Bush type

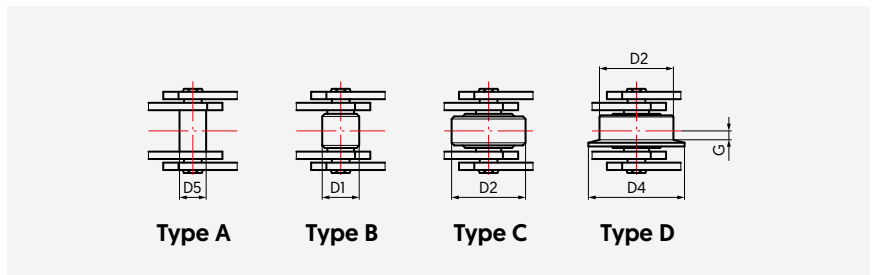

Type B – Small roller



Type C – Large roller



Type D – Flange roller

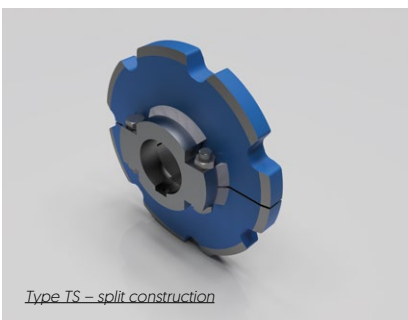

Sprockets with split construction are preferred for ease of replacement (Type TS). The tooth form incorporates John Kings unique profile allowing for increased gap angle and bottom line clearance to prevent material packing and reduced wear rate during operation.

Material options: • BS970 080M40 carbon steel suitable for surface hardening to 550Bnh at a minimum effective depth of 2.5 mm • BS EN 10025 S355J2 high strength steel • Other options available on request.



Pressed bush, welded pin



Welded bush, welded pin



Pressed bush, riveted pin

Special attention should be applied to options in construction.

M Series Metric Conveyor Chains DIN8167 (ISO1977)

Chain Number	Pitch	Rollers				Bushings	Pins	Over All Pin & Cotter		Between Sidebars	Sidebars		Breaking Load		
		Style			Flange thickness	Diameter		F1	F2	L	Thickness	Height	DIN standard	John King*	
	P	D1	D2	D4	G	D5	D6	F1	F2	L	S	H	DIN standard	John King*	
mm														kN	
M80	80	25	50	60	7	18	12	54.5	32	28	5	35	80	125	
M80	100	25	50	60	7	18	12	54.5	32	28	5	35	80	125	
M80	125	25	50	60	7	18	12	54.5	32	28	5	35	80	125	
M80	160	25	50	60	7	18	12	54.5	32	28	5	35	80	125	
M80	200	25	50	60	7	18	12	54.5	32	28	5	35	80	125	
M112	80	30	60	75	7.5	21	15	66	35	32	6	40	112	175	
M112	100	30	60	75	7.5	21	15	66	35	32	6	40	112	175	
M112	125	30	60	75	7.5	21	15	66	35	32	6	40	112	175	
M112	160	30	60	75	7.5	21	15	66	35	32	6	40	112	175	
M112	200	30	60	75	7.5	21	15	66	35	32	6	40	112	175	
M160	100	36	70	90	8.5	25	18	72	43	37	7	50	160	260	
M160	125	36	70	90	8.5	25	18	72	43	37	7	50	160	260	
M160	160	36	70	90	8.5	25	18	72	43	37	7	50	160	260	
M160	200	36	70	90	8.5	25	18	72	43	37	7	50	160	260	
M160	250	36	70	90	8.5	25	18	72	43	37	7	50	160	260	
M224	125	42	85	100	10	30	21	88	47	43	8	60	224	340	
M224	160	42	85	100	10	30	21	88	47	43	8	60	224	340	
M224	200	42	85	100	10	30	21	88	47	43	8	60	224	340	
M224	250	42	85	100	10	30	21	88	47	43	8	60	224	340	
M224	315	42	85	100	10	30	21	88	47	43	8	60	224	340	
M315	160	50	100	120	12	36	25	102	55	48	10	70	315	520	
M315	200	50	100	120	12	36	25	102	55	48	10	70	315	520	
M315	250	50	100	120	12	36	25	102	55	48	10	70	315	520	
M315	315	50	100	120	12	36	25	102	55	48	10	70	315	520	
M315	400	50	100	120	12	36	25	102	55	48	10	70	315	520	
M450	200	60	120	140	14	42	30	118	66	56	12	80	450	700	
M450	250	60	120	140	14	42	30	118	66	56	12	80	450	700	
M450	315	60	120	140	14	42	30	118	66	56	12	80	450	700	
M450	400	60	120	140	14	42	30	118	66	56	12	80	450	700	
M630	250	70	140	170	16	50	36	138	74	66	14	100	630	1050	
M630	315	70	140	170	16	50	36	138	74	66	14	100	630	1050	
M630	400	70	140	170	16	50	36	138	74	66	14	100	630	1050	
M630	500	70	140	170	16	50	36	138	74	66	14	100	630	1050	
M900	250	85	170	210	18	60	44	158	89	78	16	120	900	1250	
M900	315	85	170	210	18	60	44	158	89	78	16	120	900	1250	
M900	400	85	170	210	18	60	44	158	89	78	16	120	900	1250	
M900	500	85	170	210	18	60	44	158	89	78	16	120	900	1250	

Pressed bush with welded or riveted pin

Welded or pressed bush with welded or riveted pin

* Breaking Load with heat treated Plates

John King EXCEL Standard SFS2380

For M series [DIN 8167] and FV series [DIN 8165] John King offer an updated version to improve performance within more demanding applications. This comes under **the Scandinavian standard SFS2380**. Dimensionally as M and FV series, but with **pin and bush welded to the side plates**. This has the immediate and positive effect of **increasing breaking strength by up to 50% as well as improving impact resistance, shock loading and general service performance**.

DIN 8165

FV Series Chains.



The second series of metric conveyor chains is the FV standard comparable to M but varying in dimensions and breaking strengths. Construction of the chains is equivalent to M as are the higher specification materials and heat treatments employed by John King.

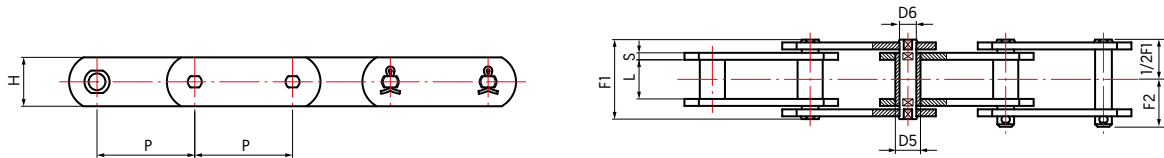

Type A – Bush type

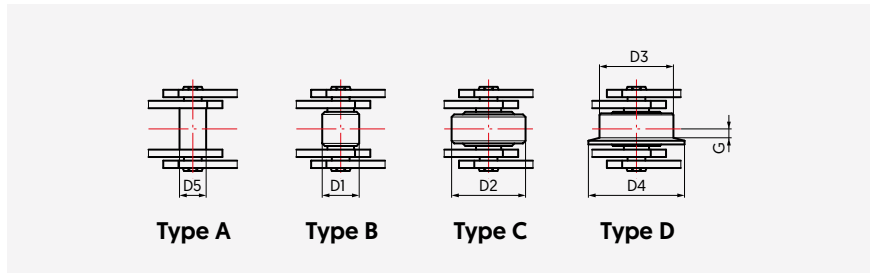

Type B – Small roller



Type C – Large roller



Type D – Flange roller

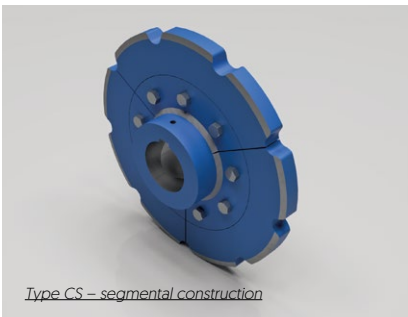

Sprockets of segmental construction include bolt on tooth rings for obvious benefit in replacement (Type CS). The tooth form incorporates John Kings unique profile allowing for increased gap angle and bottom line clearance to prevent material packing and reduced wear rate during operation.

Material options: • BS970 080M40 carbon steel suitable for surface hardening to 550Bnh at a minimum effective depth of 2.5 mm • BS EN 10025 S355J2 high strength steel • Other options available on request.



Pressed bush, welded pin



Welded bush, welded pin



Pressed bush, riveted pin

Special attention should be applied to options in construction.

FV Series Metric Conveyor Chains DIN 8165

Chain Number	Pitch	Rollers					Bushings	Pins	Over-All Pin & Cotter		Between Sidebars	Sidebars		Breaking Load	
		Style				Flange thickness	Diameter	Thickness				Height			
	P	D1	D2	D3	D4	G	D5	D6	F1	F2	L	S	H	DIN standard	John King*
	mm														kN
FV63	63	26	40	50	63	5	18	12	45	26	22	4	30	64	75
FV63	80	26	40	50	63	5	18	12	45	26	22	4	30	64	75
FV63	100	26	40	50	63	5	18	12	45	26	22	4	30	64	75
FV63	125	26	40	50	63	5	18	12	45	26	22	4	30	64	75
FV63	160	26	40	50	63	5	18	12	45	26	22	4	30	64	75
FV90	63	30	48	63	78	6.5	20	14	53	30	25	5	35	100	115
FV90	80	30	48	63	78	6.5	20	14	53	30	25	5	35	100	115
FV90	100	30	48	63	78	6.5	20	14	53	30	25	5	35	100	115
FV90	125	30	48	63	78	6.5	20	14	53	30	25	5	35	100	115
FV90	160	30	48	63	78	6.5	20	14	53	30	25	5	35	100	115
FV90	200	30	48	63	78	6.5	20	14	53	30	25	5	35	100	115
FV90	250	30	48	63	78	6.5	20	14	53	30	25	5	35	100	115
FV112	100	32	55	72	90	7.5	22	16	62	35	30	6	40	120	170
FV112	125	32	55	72	90	7.5	22	16	62	35	30	6	40	120	170
FV112	160	32	55	72	90	7.5	22	16	62	35	30	6	40	120	170
FV112	200	32	55	72	90	7.5	22	16	62	35	30	6	40	120	170
FV112	250	32	55	72	90	7.5	22	16	62	35	30	6	40	120	170
FV140	100	36	60	80	100	9	26	18	67	41	35	6	45	145	180
FV140	125	36	60	80	100	9	26	18	67	41	35	6	45	145	180
FV140	160	36	60	80	100	9	26	18	67	41	35	6	45	145	180
FV140	200	36	60	80	100	9	26	18	67	41	35	6	45	145	180
FV140	250	36	60	80	100	9	26	18	67	41	35	6	45	145	180
FV180	125	42	70	100	125	13	30	20	86	51	45	8	50	190	250
FV180	160	42	70	100	125	13	30	20	86	51	45	8	50	190	250
FV180	200	42	70	100	125	13	30	20	86	51	45	8	50	190	250
FV180	250	42	70	100	125	13	30	20	86	51	45	8	50	190	250
FV180	315	42	70	100	125	13	30	20	86	51	45	8	50	190	250
FV250	160	50	80	125	150	15	36	26	97	56	55	8	60	275	300
FV250	200	50	80	125	150	15	36	26	97	56	55	8	60	275	300
FV250	250	50	80	125	150	15	36	26	97	56	55	8	60	275	300
FV250	315	50	80	125	150	15	36	26	97	56	55	8	60	275	300
FV315	160	60	90	140	175	18	42	30	116	66	65	10	70	370	480
FV315	200	60	90	140	175	18	42	30	116	66	65	10	70	370	480
FV315	250	60	90	140	175	18	42	30	116	66	65	10	70	370	480
FV315	315	60	90	140	175	18	42	30	116	66	65	10	70	370	480
FV315	400	60	90	140	175	18	42	30	116	66	65	10	70	370	480
FV400	160	60	100	150	185	20	44	32	132	76	70	12	70	400	640
FV400	200	60	100	150	185	20	44	32	132	76	70	12	70	400	640
FV400	250	60	100	150	185	20	44	32	132	76	70	12	70	400	640
FV400	315	60	100	150	185	20	44	32	132	76	70	12	70	400	640
FV400	400	60	100	150	185	20	44	32	132	76	70	12	70	400	640
FV500	160	70	110	160	195	21	50	36	142	81	80	12	80	500	750
FV500	200	70	110	160	195	21	50	36	142	81	80	12	80	500	750
FV500	250	70	110	160	195	21	50	36	142	81	80	12	80	500	750
FV500	315	70	110	160	195	21	50	36	142	81	80	12	80	500	750
FV500	400	70	110	160	195	21	50	36	142	81	80	12	80	500	750
FV500	500	70	110	160	195	21	50	36	142	81	80	12	80	500	750

Pressed bush with welded or riveted pin

Welded or pressed bush with welded or riveted pin

* Breaking Load with heat treated Plates

METRIC CONVEYOR CHAINS DIN 8167 AND DIN 8165

Weight Table.

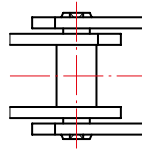

Type A

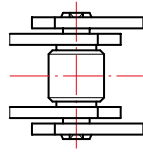

Type B

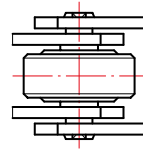

Type C

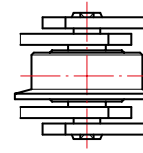

Type D

Metric Conveyor Chains ISO 1977, DIN 8167 (M Series)					
Chain Number	Pitch	Average Weight			
	P	Type A	Type B	Type C	Type D
	mm	kg/m			
M80	80	4.5	5.2	9.0	9.5
M80	100	4.2	4.7	7.8	8.1
M80	125	3.9	4.3	6.8	7.1
M80	160	3.7	4.0	5.9	6.1
M80	200	3.4	3.8	5.3	5.4
M112	80	6.7	7.7	14.0	14.6
M112	100	6.1	6.9	11.9	12.4
M112	125	5.6	6.3	10.3	10.7
M112	160	5.2	5.8	8.9	9.2
M112	200	4.6	5.5	7.9	8.2
M160	100	9.5	10.9	18.7	19.4
M160	125	8.7	9.9	16.1	16.6
M160	160	8.0	8.9	13.8	14.2
M160	200	7.5	8.2	12.1	12.5
M160	250	6.9	7.9	11.0	12.0
M224	125	12.8	14.5	25.6	26.8
M224	160	11.6	13.0	21.6	22.6
M224	200	10.8	11.9	18.8	19.6
M224	250	10.2	11.0	16.6	17.2
M224	315	9.0	10.9	14.9	15.2
M315	160	17.8	19.9	33.2	35.1
M315	200	16.4	18.1	28.8	30.3
M315	250	15.4	16.7	25.2	26.4
M315	315	14.5	15.5	22.3	23.2
M315	400	13.8	14.8	20.0	20.3
M450	200	23.8	26.8	44.9	46.9
M450	250	22.1	24.5	38.9	40.6
M450	315	20.6	22.6	34.0	35.3
M450	400	19.5	21.0	30.0	31.0
M630	250	34.2	38.0	57.4	60.8
M630	315	31.7	34.7	50.1	52.8
M630	400	29.6	32.0	44.1	46.3
M630	500	28.1	30.0	39.7	41.4
M900	250	50.7	57.4	97.5	103.9
M900	315	46.5	51.7	83.6	88.7
M900	400	43	47.2	72.2	76.2
M900	500	41.5	44.9	64.9	68.1

Metric Conveyor Chains DIN 8165 (FV Series)					
Chain Number	Pitch	Average Weight			
	P	Type A	Type B	Type C	Type D
	mm	kg/m			
FV90	63	4.84	5.98	9.17	–
FV90	80	4.40	5.52	8.12	–
FV90	100	4.07	4.78	6.79	9.59
FV90	125	3.80	4.38	5.98	8.22
FV90	160	3.57	4.02	5.28	7.02
FV90	200	3.41	3.76	4.77	6.17
FV90	250	3.28	3.56	4.37	5.48
FV112	100	5.84	6.78	10.27	14.95
FV112	125	5.43	6.18	8.97	12.71
FV112	160	5.06	5.65	7.83	10.76
FV112	200	4.80	5.27	7.02	9.36
FV112	250	4.60	4.97	6.37	8.24
FV140	100	7.09	8.34	12.98	19.63
FV140	125	6.52	7.52	11.23	16.55
FV140	160	6.02	6.81	9.70	13.86
FV140	200	5.66	6.29	8.61	11.94
FV140	250	5.38	5.88	7.74	10.10
FV180	125	10.04	11.87	18.44	30.70
FV180	160	9.22	10.85	15.78	25.36
FV180	200	8.63	9.77	13.88	21.54
FV180	250	8.16	9.07	12.36	18.49
FV180	315	7.77	8.50	11.11	15.97
FV250	160	12.11	14.56	22.25	42.01
FV250	200	11.19	13.16	19.30	35.11
FV250	250	10.46	12.03	16.95	29.60
FV250	315	9.86	11.10	15.01	25.05
FV315	160	18.76	23.22	33.83	–
FV315	200	17.21	20.78	29.26	53.72
FV315	250	15.96	18.82	25.60	45.18
FV315	315	14.94	17.20	22.59	38.12
FV315	400	14.10	15.88	20.12	32.36
FV400	160	22.06	26.41	39.80	–
FV400	200	20.29	23.77	36.45	66.19
FV400	250	18.87	21.65	31.79	55.59
FV400	315	17.70	19.91	27.95	46.84
FV400	400	16.74	18.48	24.82	39.69
FV500	160	27.07	34.28	54.41	–
FV500	200	24.67	30.44	46.55	83.05
FV500	250	22.75	27.36	40.25	69.05
FV500	315	21.17	24.83	35.06	58.23
FV500	400	19.87	22.76	30.81	49.06
FV500	500	18.91	21.22	27.66	42.26

METRIC CHAINS DIN 8167, DIN 8165

Typical attachments.

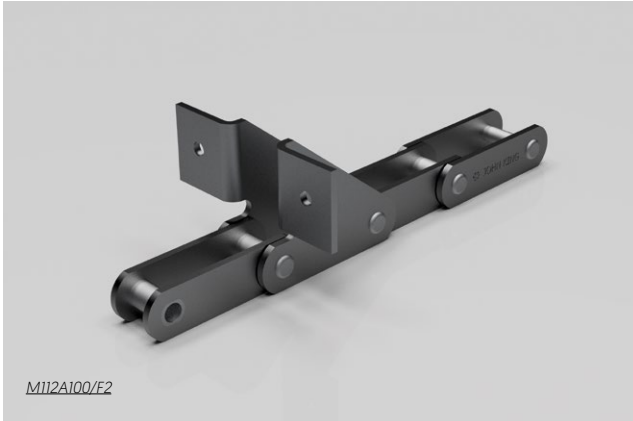

F pusher Style



L Type Style

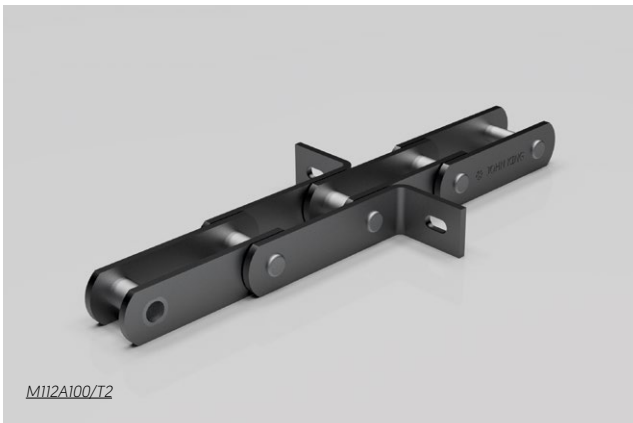

T Style

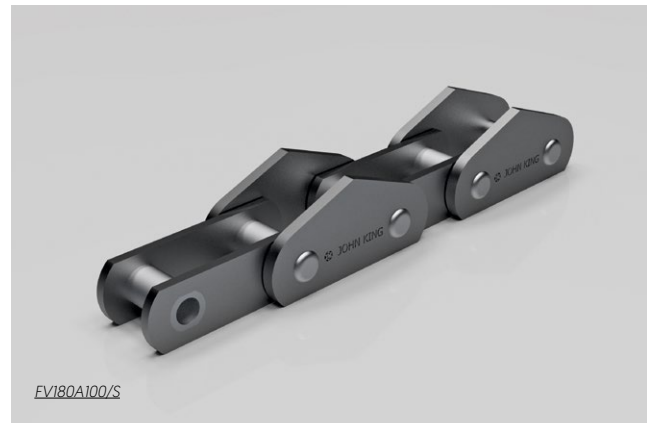

S Style

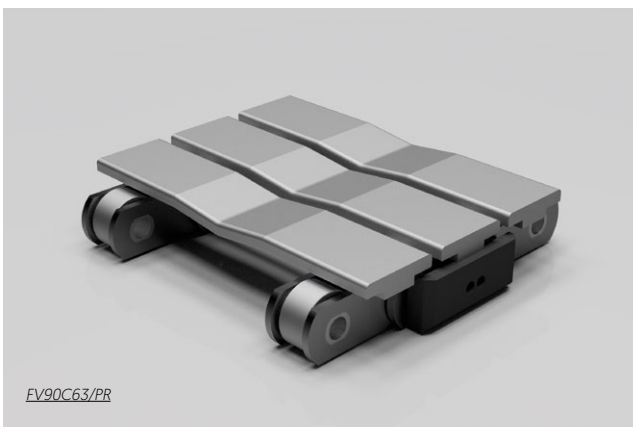

Paper Roll

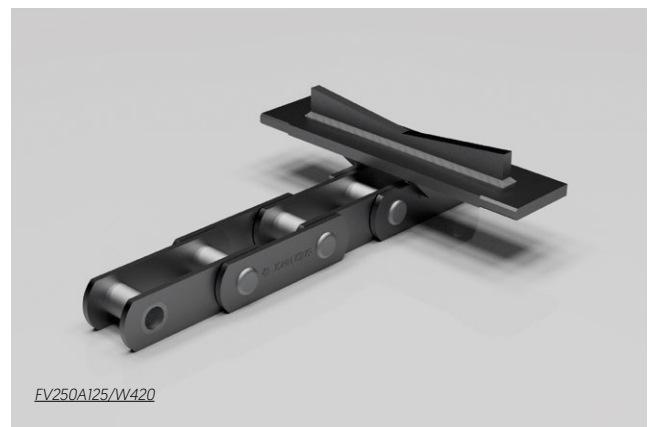

Log Cradle

CHAINS SMS 1698

Metric Welded Bush Chains.



These chains have proven to be the most reliable conveying medium when it comes to the aggressive nature of log yard applications. They are typical where continued impact and abrasion affect the operational life of the chain system employed. These chains include fully heat treated parts, with welded pin and bush to ensure maximum chain life and performance.

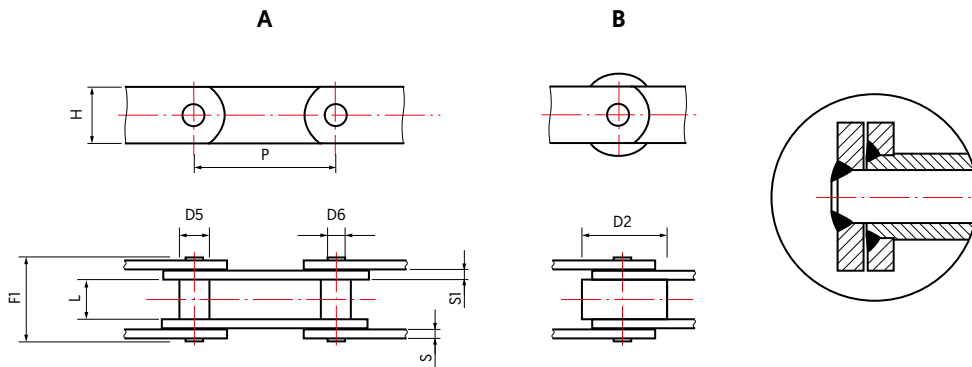

Metric Welded Bush Chains													
Chain Number	Pitch			Rollers	Bushings	Pins	Over-All	Between Sidebars	Sidebars				Breaking Load
				Diameter					Thickness			Height	
	P			D2	D5	D6	F1	L	S1	S	S, Grov	H	kN
	mm												
JKB5,5	63	80	100	40	18	12	50	22	5	4	6	30	55
JKB8,5	80	100	150	50	20	14	59	25	6	5	8	35	85
JKB12,5	100	150	–	60	25	18	75	35	8	6	8	40	125
JKB18	150	200	–	70	30	20	91	45	8	6	10	50	240
JKB24	150	200	250	80	36	26	110	55	10	8	12	60	350
JKB30	150	200	250	90	42	30	121	65	10	8	12	70	400
JKB40	200	250	–	110	50	36	142	80	12	10	12	80	520
JKB65	200	250	–	110	50	36	154	80	15	–	15	90	800
JKB500	160	200	–	55	40	26	124	65	12	–	12	70	500

Options [*] Specifications (x) = basic	JKB5,5	JKB8,5	JKB12,5	JKB18	JKB24	JKB30	JKB40	JKB65	JKB500
* Side plates with induction hardened wear surfaces	–	–	–	*	*	*	*	*	*
With case hardened bushings	x	x	x	x	x	x	x	x	x
With case hardened pins	–	–	–	x	x	x	x	x	x
With induction hardened pins	x	x	x	–	–	–	–	–	–
With welded pins	*	*	*/x	x	x	x	x	x	x
With welded bushings	–	–	–	*/x	x	x	x	x	x
With stainless pins + bushings	*	*	*	*	*	*	*	*	*
Side plates with smoothed corners	*	*	*	*	*	*	*	*	*
Lubricated joints	x	x	x	x	x	x	x	x	x

FVT Deep Link Chains with Top Plates.

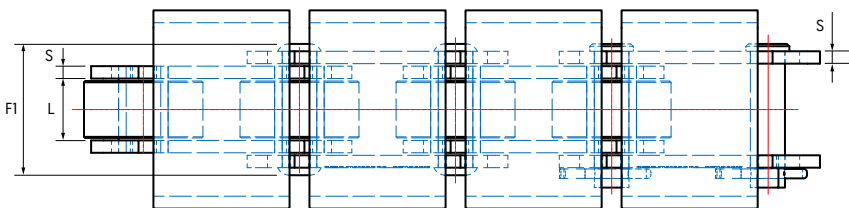
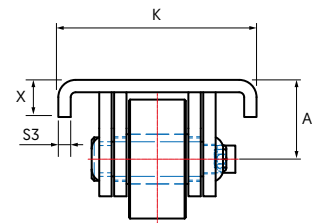
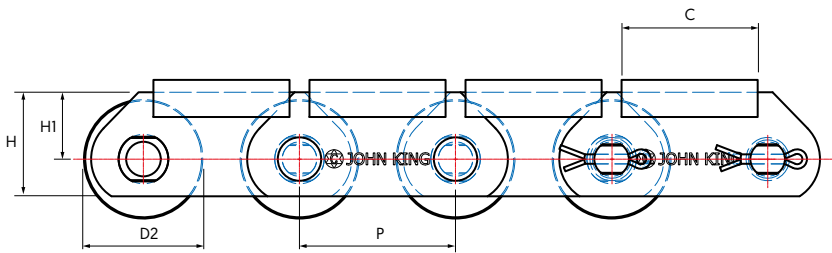
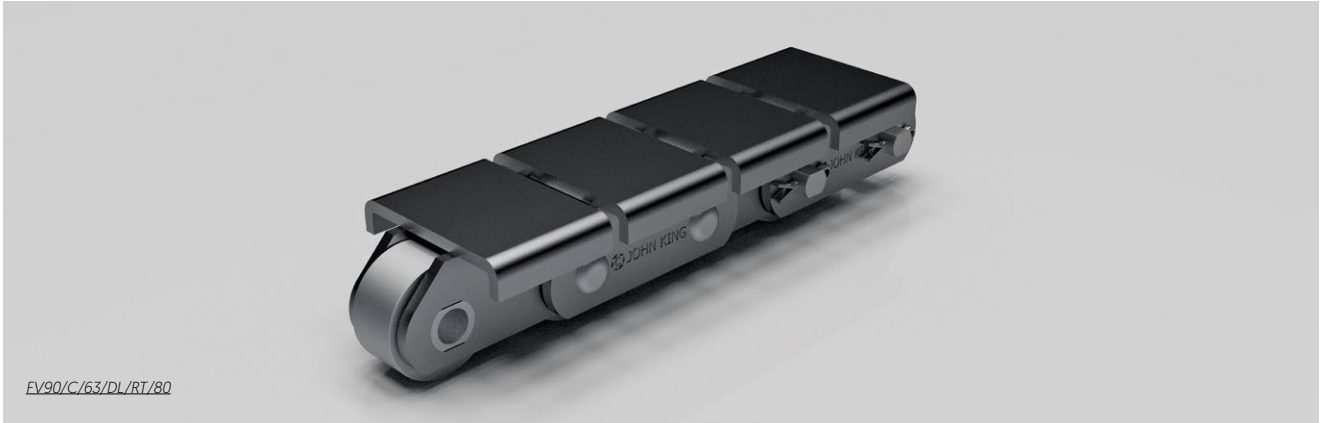

FVT Deep Link Chains with Top Plates

Chain Number	Pitch	Roller Diameter	Over-All Pin	Between Sidebars	Sidebars			K	C	A	S3	X	Ultimate Breaking Load	Maximum Allowable Load	Weight
					Thickness	H	Height								
	P	D2	F1	L	S	H	H1	mm			kN	kN	kg/m		
FVT40/C/S3/RT59.5	40	32	37.5	18	3	35	22.0	59.5	32	26.0	4	15	54	7.71	7.4
FVT40/C/S4/RT59.5	40	32	40.7	18	4	35	22.0	59.5	32	26.0	4	15	40	5.71	8.4
FVT90/C/RT80	63	48	51.9	25	5	45	27.5	80	55	32.5	5	15	107	15.28	14.5

Roller Chains with Carrier Pads.

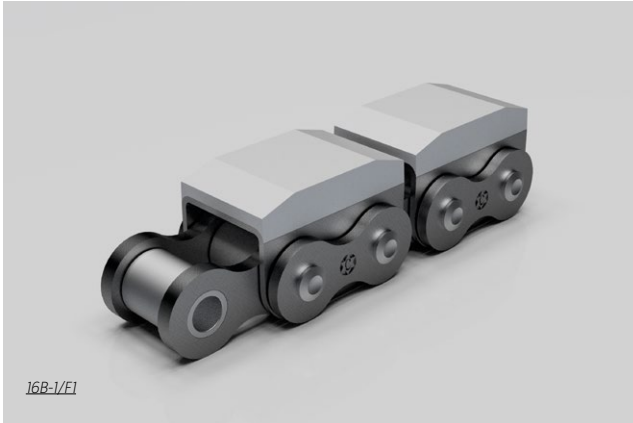

16B-1/F1

Nitrile Rubber

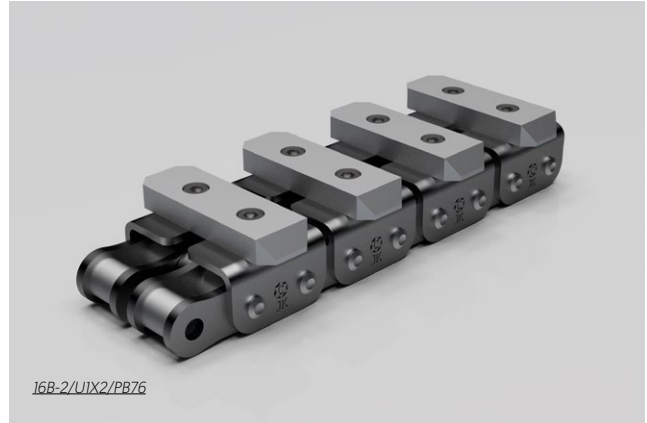

16B-2/U1X2/PB76

Aluminium Pad

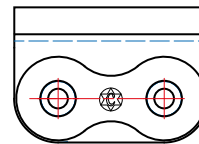
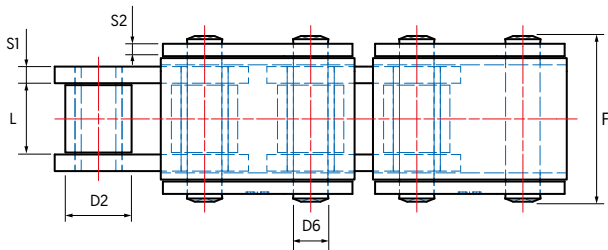
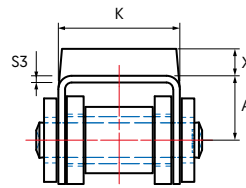
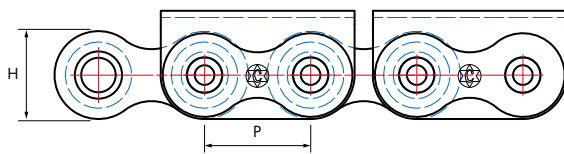

Profile G1

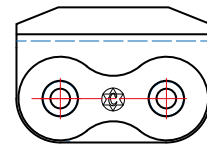

Profile F1

Roller Chains with Rubber Blocks

Chain Number	Pitch	Roller	Pins	Over-All Pin	Between Sidebars	Sidebars			K	A	S3	X	Ultimate Breaking Load	Maximum Allowable Load	Weight
		Diameter				Thickness	Height								
	P	D2	D6	F1	L	S1	S2	H	mm	kN	kN	kg/m			
08B-1/G1	12.70	8.51	4.45	20.00	7.75	1.60	1.60	11.80	14.60	8.30	1.60	4.00	18.00	2.57	1.19
10B-1/G1	15.88	10.16	5.08	23.20	9.65	1.60	1.60	14.70	16.80	11.30	1.60	5.70	19.00	2.71	1.62
12B-1/G1	19.05	12.07	5.72	25.70	11.68	1.80	1.80	16.00	19.60	13.00	1.85	8.00	29.00	4.14	2.01
16B-1/G1	25.40	15.88	8.28	39.70	17.02	4.00	3.00	21.00	29.10	15.40	1.60	6.00	58.00	8.28	3.83
16B-1/F1	25.40	15.88	8.28	39.70	17.02	4.00	3.00	21.00	29.10	15.40	1.60	6.00	58.00	8.28	3.83
20B-1/G1	31.75	19.05	10.19	48.00	19.56	4.50	3.50	26.40	36.00	21.00	3.50	6.00	85.00	12.14	6.19
24B-1/G1	38.10	25.40	14.63	63.40	25.40	6.00	5.00	33.40	47.00	28.00	4.50	6.00	160.00	22.85	11.25

Chip Press Chains.

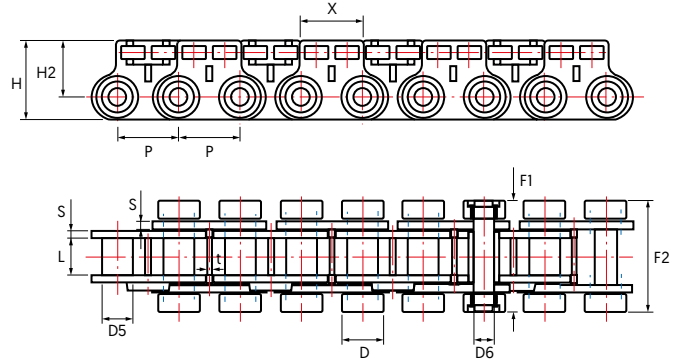
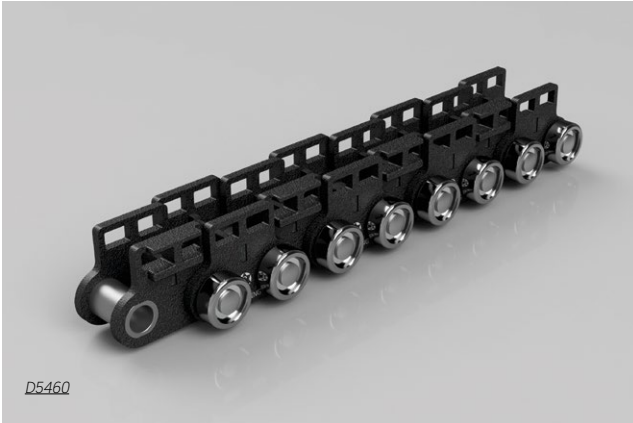

Chip Press Chains													
Chain Number	Pitch P	Bushings Diameter		D	Pins Length F1	Over-All F2	Between Sidebars L	Sidebars		H2	X	t	Tensile Strength kN
		D5	D6					Thickness S	Height H				
	mm												
D5460	40	25	14	28	73	75	20	5	53	38	42	4	90

Climax Case Chains.

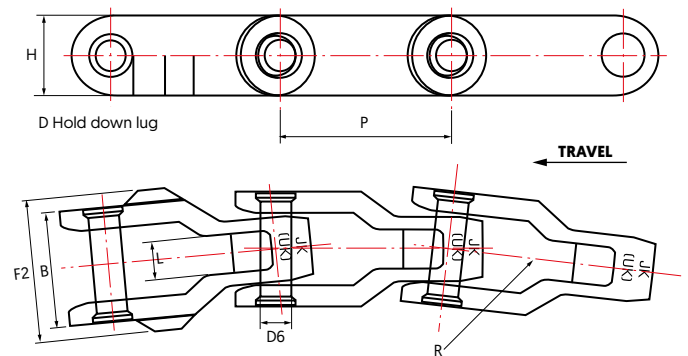

Climax Case Chains									
Chain Number	Average Pitch	Pin Diameter	Over-All	Sprocket Face	Length of Bearing	Sidebars Height	Number of Links in 10 Ft	Average Weight	Minimum Turning Radius
	P	D6	F1	L	B	H		lbs/ft	inches
	inches								
CC600	2.50	0.44	1.69	0.50	1.69	1.13	48	11.40	19
CC600D	2.50	0.44	2.13	0.50	1.69	1.13	48	12.20	19
CC1300	3.25	0.56	2.06	0.38	2.06	1.50	37	11.30	40
CC1300D	3.25	0.56	2.69	0.38	2.06	1.50	37	13.00	40

RHINO Cast Combination Chains for Log Infeed Conveyors.

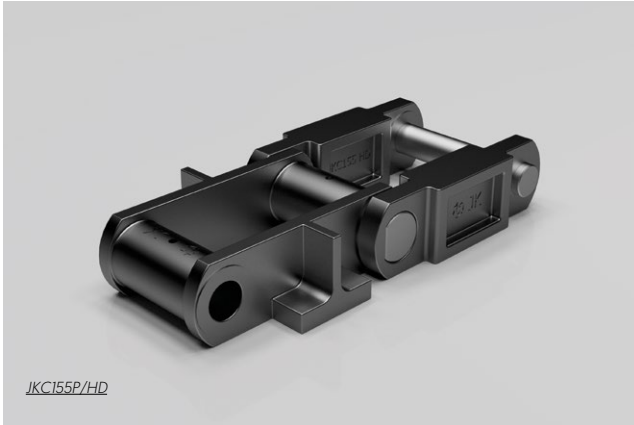

The Rhino series chain calls on John King's long experience going back to the middle of the last century as Manufacturers of cast link chains. In the case of Rhino series both centre block and sidebars are produced from a high alloy direct hardening steel according to JK/BT3. This is employed in the hardened and tempered condition at a level that maximises the mechanical properties in high duty applications where high impact and abrasion are commonplace. The chain has proven its value in the most demanding timber applications Worldwide.

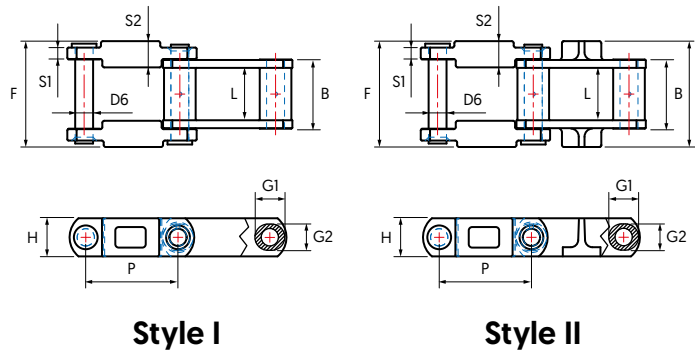

RHINO Cast Combination Chains for Log Infeed Conveyors

Chain Number	Style	Units	Pitch	Pins		G1	G2	Over-All	Between Sidebars	Length of Bearing	Sidebars			Maximum Working Load	Ultimate Strength	Average Weight
				Diameter	D6						Thickness		Height			
											S1	S2				
JKC124/HD	I	in	4.06	0.88	1.88	1.63	4.75	2.00	3.00	0.63	–	2.00	22,800 lbs	148,600 lbs	14.9 lbs/ft	
		mm	103.12	22.35	47.75	41.40	120.65	50.80	76.20	16.00	–	50.80	10,342 kg	67,404 kg	22.2 kg/m	
JKC132/HD	II	in	6.05	1.09	2.00	1.75	6.81	3.31	4.31	0.75	–	2.00	32,800 lbs	214,000 lbs	16.3 lbs/ft	
		mm	153.67	27.69	50.80	44.45	172.97	84.07	109.47	19.05	–	50.80	14,878 kg	97,069 kg	24.3 kg/m	
JKC155/HD	I	in	6.05	1.13	2.00	1.75	6.69	3.31	4.31	0.75	1.64	2.50	35,000 lbs	230,000 lbs	20.7 lbs/ft	
		mm	153.67	28.70	50.80	44.45	169.93	84.07	109.47	19.05	41.66	63.50	15,876 kg	104,326 kg	30.8 kg/m	
JKC155P/HD	II	in	6.05	1.13	2.00	1.75	6.69	3.31	4.31	0.75	1.64	2.50	35,000 lbs	230,000 lbs	23.0 lbs/ft	
		mm	153.67	28.70	50.80	44.45	169.93	84.07	109.47	19.05	41.66	63.50	15,876 kg	104,326 kg	34.2 kg/m	
JKC157/HD	I	in	6.08	1.22	2.13	1.84	6.95	3.38	4.63	0.84	1.73	2.50	41,800 lbs	270,000 lbs	23.6 lbs/ft	
		mm	154.43	30.99	54.10	46.74	176.53	85.85	117.60	21.34	43.94	63.50	18,960 kg	122,470 kg	35.1 kg/m	
JKC157P/HD	II	in	6.08	1.22	2.13	1.84	6.95	3.38	4.63	0.84	1.73	2.50	41,800 lbs	270,000 lbs	24.8 lbs/ft	
		mm	154.43	30.99	54.10	46.74	176.53	85.85	117.60	21.34	43.94	63.50	18,960 kg	122,470 kg	36.9 kg/m	
JKC159P/HD	II	in	6.13	1.28	2.25	2.00	6.95	3.37	4.62	0.84	1.73	3.00	50,000 lbs	324,000 lbs	28.8 lbs/ft	
		mm	155.70	32.51	57.15	50.80	176.53	85.60	117.35	21.34	43.94	76.20	22,680 kg	146,964 kg	42.9 kg/m	

John King RHINO range are the strongest, most wear resistant chain systems available designed to offer a simplified and robust construction as compared to the original OEM selection.

They are produced from cast alloy steels that provide the optimum combination of impact, fatigue and wear performance. John Kings were the innovators in cast link combination chains. There is nothing new about the one piece casting technology. It is our focus on continuous improvement that has made this product the best option in the market place.

The versatility of cast link chains can be highlighted in the material options. For the Rhino range chains can be produced in a multiplicity of material grades commensurate with the environment and the duty. John King offer two standards for best and proven performance. Other cast materials are available on request.

Material table																	
John King	British Standard Material Designation	American Material Designation	DIN	CHEMICAL COMPOSITION (figs are % maxima except where noted or where range is shown)									Tensile Strength	Proof Stress	CHARNY (impact value at 20°C unless otherwise shown)	Brinell Hardness	Elongation
				C	Si	Mn	S	P	Cr	Ni	Mo						
				%													
ALLOY STEELS																	
JK/BT3	BS10283 BT3	AISI 8630	1.6546	0.28-0.33	0.15-0.30	0.65-0.95	0.03	0.03	0.40-0.60	0.35-0.75	0.15-0.25	1000-1160 (65-75)	695 (45)	20	293-341	6	
WEAR RESISTANT STEELS																	
JK/MN	BS10283 BW10	AISI A128 Grade A	1.3401	1.00-1.25	1.00	11.00 min	0.06	0.07	2	-	-	-	-	-	-	-	

Note: Add suffix **MN** or **BT3** to chain code to denote material grade employed.

Cast Integral Log Cradle Attachments.

Integral Cast M attachment.

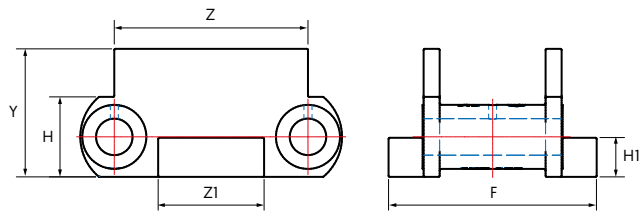
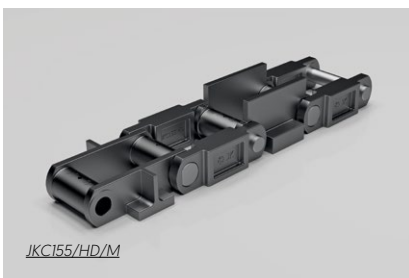

M Attachment (integral guide blocks)														
Chain Number	F		Z		Z1		Y		H		H1		Average Weight	
	inches	mm	inches	mm	inches	mm	inches	mm	inches	mm	inches	mm	lbs	kg
JKC132/HD/M300	6.50	165.1	6.05	153.67	3.31	84.0	3.00	76.20	2.00	50.8	0.75	19.05	10.00	4.54
JKC155/HD/M325	6.50	165.1	6.05	153.67	3.31	84.0	3.25	82.55	2.50	63.5	1.25	31.75	13.00	5.90
JKC155/HD/M350	6.50	165.1	6.05	153.67	3.31	84.0	3.50	88.90	2.50	63.5	1.25	31.75	13.50	6.12
JKC155/HD/M400	6.50	165.1	6.05	153.67	3.31	84.0	4.00	101.60	2.50	63.5	1.25	31.75	14.20	6.44
JKC157/HD/M325	7.09	180.0	6.08	154.43	3.37	85.6	3.25	82.55	2.50	63.5	1.25	31.75	13.28	6.02
JKC157/HD/M350	7.09	180.0	6.08	154.43	3.37	85.6	3.50	88.90	2.50	63.5	1.25	31.75	13.80	6.26
JKC157/HD/M400	7.09	180.0	6.08	154.43	3.37	85.6	4.00	101.60	2.50	63.5	1.25	31.75	14.83	6.73

Integral S Pusher.

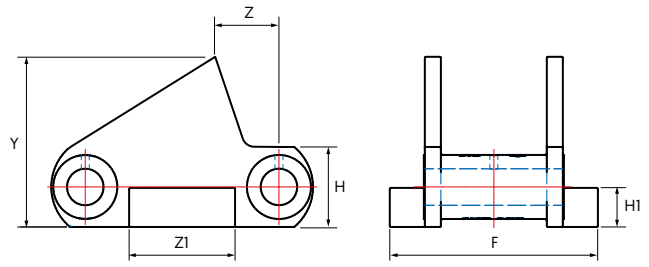
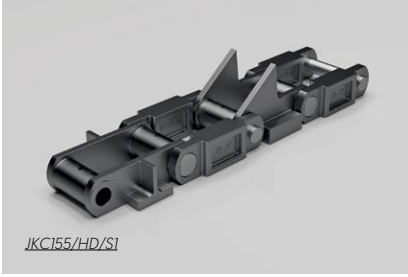

Integral S Pusher (integral guide blocks)

Chain Number	F		Z		Z1		Y		H		H1		Average Weight	
	inches	mm	inches	mm	inches	mm	inches	mm	inches	mm	inches	mm	lbs	kg
JKC124/HD/S1	6.50	165.1	0.5	12.7	3.43	87.12	5.25	133.35	2.50	63.5	1.25	31.75	13.00	5.90
JKC155/HD/S1	7.13	181.10	0.5	12.7	3.43	87.12	5.25	133.35	2.50	63.5	1.25	31.75	14.80	6.71

RT Style Round Top.

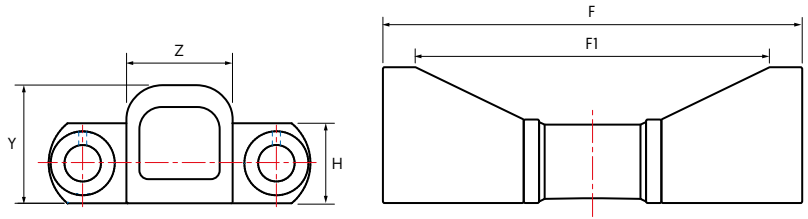
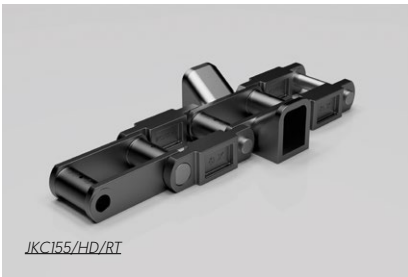

B Style Round Top

Chain Number	F		F1		H		Y		Z		Average Weight	
	inches	mm	inches	mm	inches	mm	inches	mm	inches	mm	lbs	kg
JKC124/HD/RT	10.00	250	9.00	230.00	2.0	50.8	2.50	63.50	2.5	63.50	14.85	6.75
JKC155/HD/RT	17.75	450	10.00	254.00	2.5	63.5	4.25	108.00	3.50*	88.90	28.70	13.00

ST Style Sharp Top Cradle Attachment.

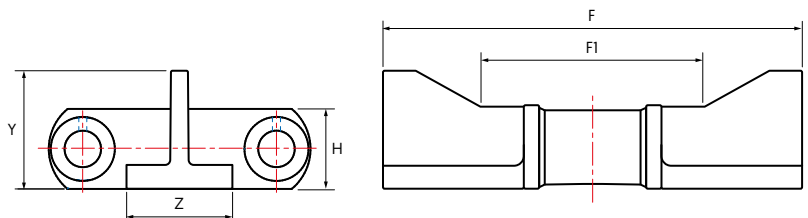
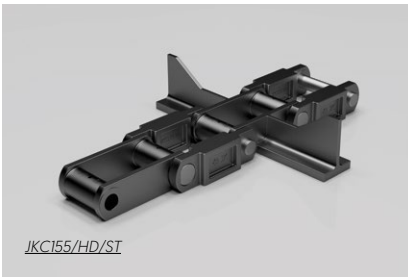

A Style Sharp Top Cradle Attachment

Chain Number	F		F1		H		Y		Z		Average Weight	
	inches	mm	inches	mm	inches	mm	inches	mm	inches	mm	lbs	kg
JKC124/HD/ST	15.74	250	9.00	230.00	2.0	50.8	3.88	63.50	2.50	63.50	11.00	5.00
JKC155/HD/ST	17.71	450	10.00	254.00	2.5	63.5	4.38	111.13	3.0	76.20	23.50	10.68

Flight width can be reduced to customer requirements.

Flight width can be reduced to customer requirements.

H Style Drop Centre Flight

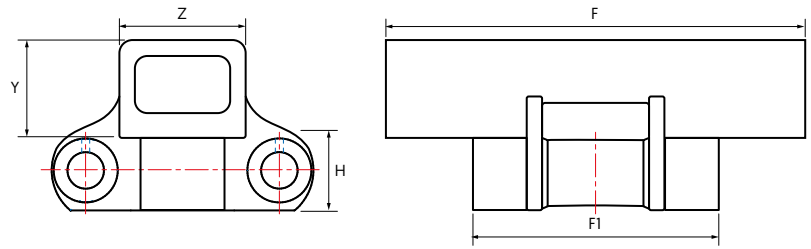
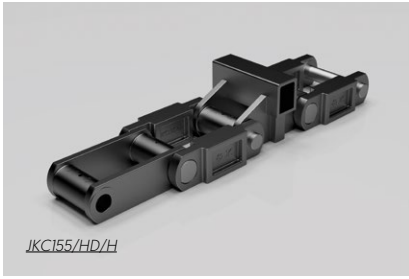

H Style Drop Centre Flight

Chain Number	F		F1		H		Y		Z		Average Weight	
	inches	mm	inches	mm	inches	mm	inches	mm	inches	mm	lbs	kg
JKC124/HD/H	4.25	108	–	–	2.0	50.8	1.25	31.80	1.25	31.80	7.40	3.36
JKC155/HD/H	6.38	162	6.5	111.25	2.5	63.5	2.50	63.50	2.00	63.50	15.60	7.00

RF Flush Style Pusher Flight

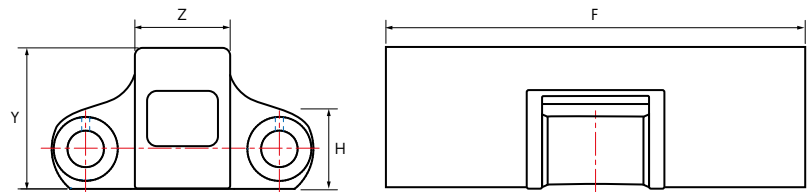
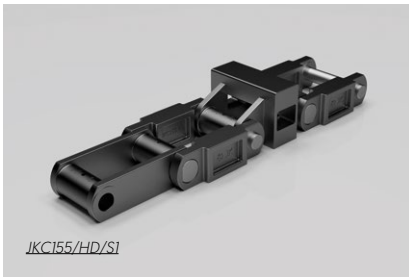

RF Flush Style Pusher Flight

Chain Number	F		H		Y		Z		Average Weight	
	inches	mm	inches	mm	inches	mm	inches	mm	lbs	kg
JKC124/HD/RF	4.25	108	2.0	50.8	2.25	57.15	2.00	50.80	8.36	3.80
JKC155/HD/RF	6.38	162	2.5	63.5	5.5	228.60	2.50	63.50	16.50	7.50

SQL Square Section Long Link Chains.



Chains of robust and simple construction that offer maximum reliability and extended service.

The technology applied is to produce a chain of the most simple and robust construction suitable for bark, chip and wood waste transport. The chain is therefore of an open and simple construction with square section as opposed to round section to maximise cross sectional area and contact surfaces to maximise interlink wear resistance and sliding surfaces within the conveyor. The casting techniques employed are unique with chains being cast in multiple link sections. John King offer two standard material grades which over time have proven to offer the best mechanical characteristics and consequentially service performance although the versatility of the casting process allows for a wide range of material grades to suit the customer's specific requirements. For more information visit the JK web site under 18.6 – John King irons and steels.



Material table																	
John King	British Standard Material Designation	American Material Designation	DIN	CHEMICAL COMPOSITION (figs are % maxima except where noted or where range is shown)									Tensile Strength	Proof Stress	CHARPY (impact value at 20°C unless otherwise shown)	Brinell Hardness	Elongation
				C	Si	Mn	S	P	Cr	Ni	Mo						
				%													
ALLOY STEELS																	
JK/BT3	BS10283 BT3	AISI 8630	1.6546	0.28-0.33	0.15-0.30	0.65-0.95	0.03	0.03	0.40-0.60	0.35-0.75	0.15-0.25	1000-1160 [65-75]	695 [45]	20	293-341	6	
WEAR RESISTANT STEELS																	
JK/MN	BS10283 BW10	AISI A128 Grade A	1.3401	1.00-1.25	1.00	11.00 min	0.06	0.07	2	-	-	-	-	-	-	-	

Note: Add suffix **MN** or **BT3** to chain code to denote material grade employed.

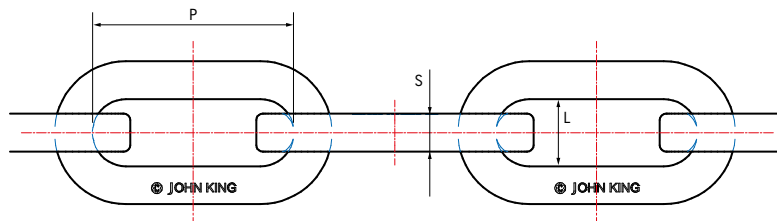

SQL Square Section Long Link Chains										
Chain Number	Pitch p	S	L	JK/MN Manganese Max. Working Load		JK/BT3 High Alloys Max. Working Load		Ultimate Strength		Estimated Weight lbs
				lbs	kN	lbs	kN	lbs	kN	
	JKSQ1.125X2X6	6	1.125	2	25,000	111.21	30,000	133.45	125,000	556.03
JKSQ1.25X2X6	6	1.25	2	30,000	133.45	36,000	160.14	150,000	667.23	16
JKSQ1.5X2.25X8	8	1.5	2.25	43,000	191.27	51,000	226.86	215,000	956.37	21
JKSQ1.75X2.5X8	8	1.75	2.5	58,000	258.00	69,000	306.93	285,000	1267.74	30

SQL Connecting links.

We have our own preferences as regards the type of connecting link, but two standards are available in materials to suit the main chain strands [stock production of JK/MN and JK/BT3].

JK/MN Lap link (L)



JK/BT3 Wedge link (W)

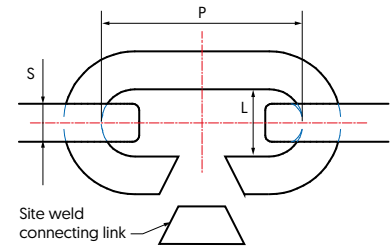

Note: Add suffix **MN** or **BT3** to chain code to denote material grade employed.

SQL Connecting links				
Chain Number	Pitch	S	L	Estimated Weight
	p			
47/JKSQ1.125X2X6	6	1.125	2	6
47/JKSQ1.25X2X6	6	1.25	2	7
47/JKSQ1.5X2.25X8	8	1.5	2.25	15
47/JKSQ1.75X2.5X8	8	1.75	2.5	21.5

SQL flight bars.

Flight bars are available in two formats dependent on the customer preference. The principal is that the flight does the work and the chain ends act as the conveying medium.

One piece FL series.

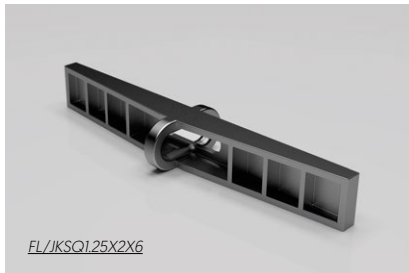

SQL One piece FL series.		
Chain Number	Height	Width
	inches	
FL/JKSQ1.125X2X6	4.5 and 5	24 up to 42
FL/JKSQ1.25X2X6	4.5 and 5	24 up to 42
FL/JKSQ1.5X2.25X8	5 and 6	26 up to 48
FL/JKSQ1.75X2.5X8	5 and 6	26 up to 48

The FL flight allows for connection of the chain ends either by utilising a **L** lap link or **W** wedge link to connect to the flight fixed loop.

Double tang chain flight DT series.

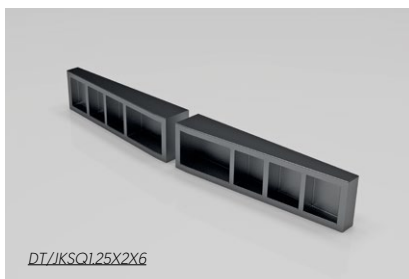

SQL One piece FL series.		
Chain Number	Height	Width
	inches	
DT/JKSQ1.125X2X6	4.5 and 5	24 up to 42
DT/JKSQ1.25X2X6	4.5 and 5	24 up to 42
DT/JKSQ1.5X2.25X8	6	26 up to 48
DT/JKSQ1.75X2.5X8	6	26 up to 48

The DT flight is made up of two identical flights that enclose the link and allow for welding of chain and flight tangs to make the elements one piece. The flight is cast from an alloy which is subsequently heat treated for toughness and wear resistance but remains fully weldable. The advantage of this option is that chain lengths can be increased and the flight bars dropped in at any preferred spacing within the chain.

Chain drive sprockets with detachable teeth.



John King favour replaceable tooth drums since maintenance is comparatively easy. The form allows for a generous lead in so the chain is guaranteed to contact in an orderly manner. The centre drive peg engages with the horizontal link allowing for a smooth gearing action.

Detachable teeth are produced from an alloy steel but tempered back to a hardness that is generous to the chain and establishes the teeth as the sacrificial element.

Chain drive sprockets of solid construction.



The one piece drive ring is produced in the same material options as the chain so JK/MN with work hardening qualities. The abrasive nature of bark and waste wood transport with a high level of contaminants allows the manganese steel to develop the work hardening qualities for which it its renowned achieving in excess of 500 Bnh in the right conditions. Guide drums are combined with the chain ring to create a support for the flights and prevent material build up in this critical area.

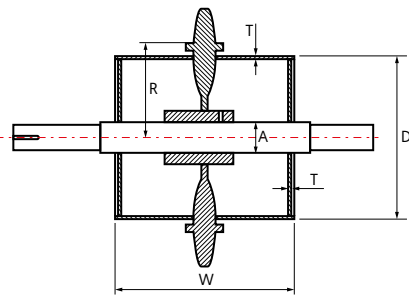

Chain drive sprockets of solid construction					
Sprocket Number	Drum			Radius	Bore Sizes
	D	W	T	R	A
inches					
5 TOOTH					
41/JKSQ1.125X2X6/5T	14	As required	0.5	8.875	2.4375 – 3.9375
41/JKSQ1.25X2X6/5T	14	As required	0.5	8.125	2.4375 – 3.9375
7 TOOTH					
41/JKSQ1.125X2X6/7T	20	As required	0.5	12.25	2.9375 – 5.4375
41/JKSQ1.25X2X6/7T	20	As required	0.5	12.1875	2.9375 – 7

Chain idler drums.



It is John King preference proven over time, to fabricate tail drums from pre hardened plate with a hardness of a minimum of 450 Bnh. This ensure the unit operates almost maintenance free for an extended period. The ends are closed with flanged plates preventing material accumulation whilst adding strength and rigidity.

The centre groove encapsulates the vertical link acting as a guide so the dimensions of the groove are critical to ensure easy entry and exit.

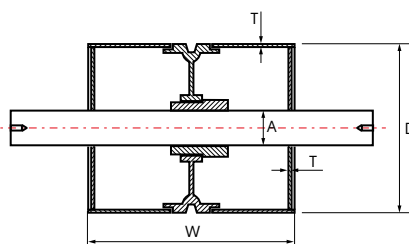

Chain idler drums			
D	Drum		Bore Sizes
	W	T	A
inches			
20	Flight width + 2	0.5	2.4375 – 3.9375
24	Flight width + 2	0.5	2.4375 – 4.9375
30	Flight width + 2	0.5	3.4375 – 5.9375
36	Flight width + 2	0.5	As required

81X Chains.

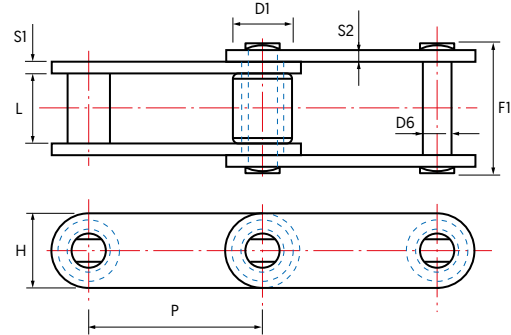

81X Chains									
Chain Number	Pitch	Rollers		Pins		Between Sidebars	Sidebars		Tensile Strength
		Diameter		Length			Thickness		
	P	D1	D6	F1	L	S1	S2	H	kN
	mm								
JKR81X	66.27	23	11.11	47.2	27	4	4	28.58	111
JKR81XH	66.27	23	11.11	58.2	27	7.94	5.56	31.75	176
JKR81XHH	66.27	23	11.11	63.5	27	7.94	7.94	31.75	186

81X RT Chains

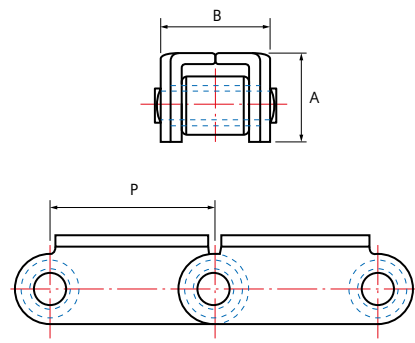

81X RT Chains			
Chain Number	Pitch	A	B
	P		
	mm		
JKR81X_RT	66.27	46.04	45

Available in XH and XHH version with UHMW or Steel Caps

Forged Link Standard Series.



This series represents the leading product within the John King programme. Forged fork link chain has proven to be one of the most reliable conveying mediums offering a combination of versatility, strength and abrasion resistance. These chains, originally of European origin, are now established worldwide. With a wide variety of materials, heat treatments and flight formats the chain is proven in both drag and enmasse handling.

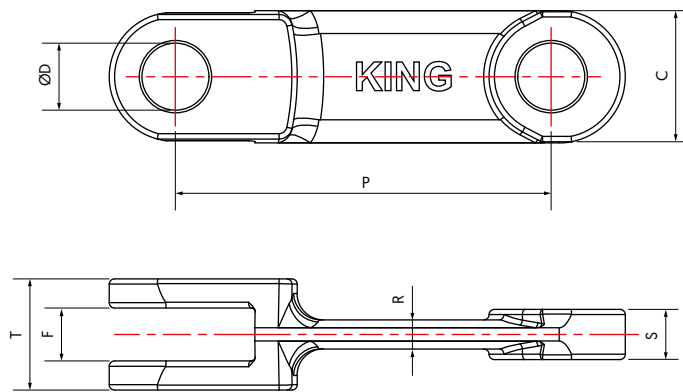

Forged Link Standard Series

Chain Number	P	T	C	S	F	R	Bolt Hole Diameter	Breaking Loads			Weight
								D	TN*	CN*	
mm								kN			kg/m
JKF 10160	101.6	24	36	8	10	6	14	110	120	210	3.50
JKF 10160R	101.6	30	36	13	14	9	14	180	195	330	4.80
JKF 12514	125	30	36	13	14	10	16	163	175	290	4.40
JKF 14214	142	30	40	13	14	9	18	180	195	330	4.90
JKF 14218	142	42	50	19	20	11	25	290	320	550	9.40
JKF 14222	142	54	50	25	27	16	25	370	400	655	12.20
JKF 14226	142	62	50	28	30	15	25	440	470	790	13.60
JKF 16018	160	46	46	22	24	15	22	320	342	560	9.30
JKF 16025	160	50	53	23	25	13	25	370	400	655	10.80
JKF 20025	200	60	50	25	27	18	25	380	410	670	11.30
JKF 20028	200	66	60	30	32	20	30	500	540	900	16.70
JKF 21640	216	64	72	26	28	20	35	585	630	1035	20.10
JKF 22040	220	64	72	26	28	20	35	585	630	1035	20.30
JKF 22050	220	58	75	28	30	25	32	710	760	1260	19.10
JKF 22060	220	71	75	31	33	21	35	735	790	1300	22.90
JKF 25040	250	70	75	32	34	18	32	735	860	1430	18.80
JKF 26035	260	65	75	31	33	20	32	840	900	1480	19.80
JKF 26040	260	70	75	31	33	20	32	840	900	1480	21.00
JKF 26045	260	78	75	35	37	20	32	930	1000	1650	21.80

Attachment hole positions and sizes can be varied to meet customer requirements.

Forged Link Double Series.



For double strand assemblies John King have a range of links following the standard format but with a forged “double clevis” into which a scraper can be mounted. The flight blade can be retained by either a U bolt or standard fasteners. The chain allows for some built in clearance between strands which obviates any potential problems that may be associated with mismatch. Double strand allows for improved discharge particularly relevant in conveying sticky materials.

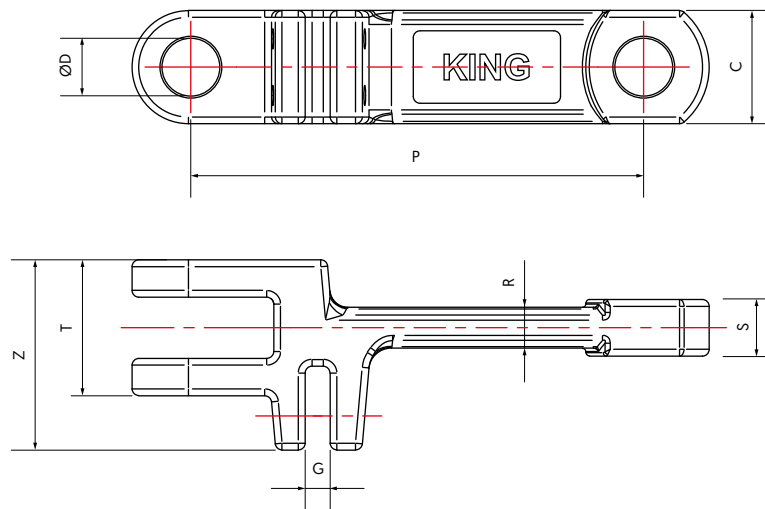

Forged Link Double Series											
Chain Number	P	T	C	S	Z	G	Bolt Hole Diameter D	Breaking Loads			Weight kg/m
								TN*	CN*	CD*	
JKF 142182	142	42	50	19	70	13	25	290	320	550	11.80
JKF 142262	142	62	50	28	87	13	25	440	470	790	16.70
JKF 160252	160	50	53	23	82	13	25	370	400	655	13.60
JKF 175402	175	72	60	30	95	16	30	540	580	955	20.30
JKF 200252	200	60	50	25	81	12	25	380	410	670	13.00
JKF 200402	200	70	60	30	95	13	30	540	580	955	19.30
JKF 250252	250	60	50	25	81	12	25	380	410	670	12.00
JKF 250402	250	70	60	30	95	13	30	540	580	955	17.70
JKF 250602	250	100	70	45	140	21	35	975	1050	1720	35.20

Forged conveyor chain.

King manufacture an unrivalled range of high quality forged chains. The standard is for an alloy steel forging and pin case hardened for wear resistance. Specifications can be varied dependent on the operating environment.

Drop forged chain links							
Material reference	JK Reference	Material No		Standard Hardening	JK Heat Treatment Designation	Standard hardening value	Standard hardening depth
		DIN	AISI				
STANDARD QUALITIES							
20CrMnTn	TN	1.8401	A29/A29M	CASE HARDENING	CH	58-62 HRC	0,8-1,0 mm
18MnCrB5	BN	1.7168	–	CASE HARDENING	CH	58-62 HRC	0,8-1,0 mm
20MnCr5	MN	1.7147	5120	CASE HARDENING	CH	58-62 HRC	0,8-1,0 mm
21NiCrMo4	CN	1.6523	8620H	CASE HARDENING	CH	58-62 HRC	0,8-1,0 mm
C45	C	1.0503	1045	HARDENING AND TEMPERING	TH	800-900 N/mm ²	
42CrMo4	CD	1.7225	4140	HARDENING AND TEMPERING	TH	1100-1300 N/mm ²	
CORROSION AND ACID RESISTANT MATERIAL							
X5CrNi 18-10 [V 2 A]	SS304	1.4301	304				
X6CrNiMoTi 17-12 2 [V 4 A]	SS316	1.4571	316				
X46Cr13	SS 420	1.4034	420	HARDENING AND TEMPERING	TH	50-52 HRC	
HEAT – RESISTANT MATERIAL							
				HEAT RESISTANCE IN AIR			
X10CrAlSi7	JK HK	1.4713		800° C MAX		420-620 N/mm ²	
X15CrNiSi 20-12	JK HH	1.4828	309	1000° C MAX		500-750 N/mm ²	
Chain pins							
Material reference	JK Reference	Material No		Standard Hardening	JK Heat Treatment Designation	Standard hardening value	Standard hardening depth
		DIN	AISI				
STANDARD QUALITIES							
	BS970 1991						
16MnCr5	590M17	1.7131	5115	CASE HARDENING	CH	58-62 HRC	0,8-1,0 mm
15NiCr13	633M13	1.5752	3310	CASE HARDENING	CH	58-62 HRC	0,8-1,0 mm
18CrNi8		1.592		CASE HARDENING	CH	58-62 HRC	0,8-1,0 mm
C45	080M46	1.0503	1045	INDUCTION HARDENING	IH	52-56 HRC	1,5-2,0 mm
				HARDENING AND TEMPERING	TH	45-50 HRC	
42CrMo4	708M40	1.7225	4140	INDUCTION HARDENING	IH	56-60 HRC	1,5-2,0 mm
				HARDENING AND TEMPERING	TH	56-60HRC	
CORROSION AND ACID RESISTANT MATERIAL							
X46Cr13	420S29	1.4034	420	HARDENING AND TEMPERING	TH	50-52 HRC	
X105CrMo17	440S49	1.4125	440	HARDENING AND TEMPERING	TH	50-55 HRC	
Circlips							
Material reference	JK Reference	Material No		Standard Hardening	JK Heat Treatment Designation	Standard hardening value	Standard hardening depth
		DIN	AISI				
STANDARD QUALITIES							
DD12	P12	1.0398	621				
Ferritic – Cromweld 3Cr12	SS410	1.4003	410				
Austenitic	SS304	1.4301	303				

Flights are robotically welded in one of three manufacturing facilities in the UK, Poland and the USA. The integrity of the welding is fundamental to best performance.

The configuration will vary dependent on the style of machine.

High Manganese Wear Rail.

The standard recommendation for forged chain wear rail is manganese steel, an austenitic structure, offering unique work hardening properties. In its rolled condition it offers a hardness value of 200-220 Bnh increasing up to 600 Bnh if the optimum conditions prevail.

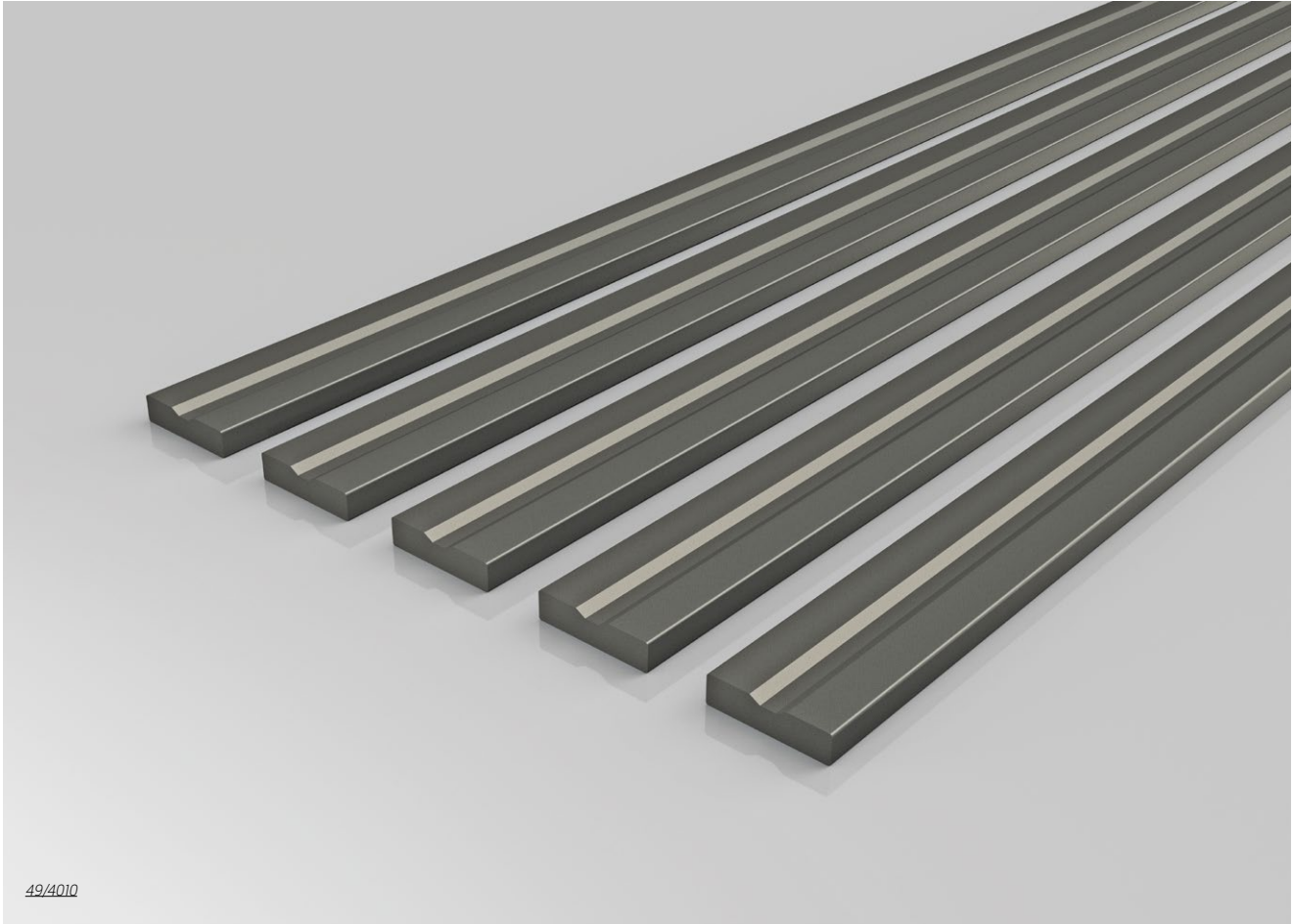

49/4010

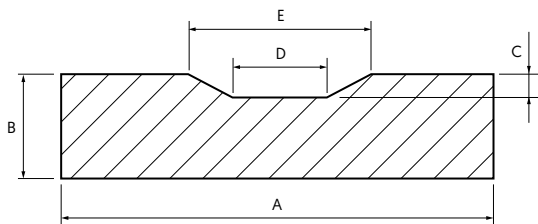

Material	DIN	Hardness	Standard Length
120mn12	1.3401	200-220 Bnh	3000mm -0/+5

High Manganese Wear Rail						
John King References	A	B	C	D	E	Weight
	mm					kg/m
49/25X10	25.0	10.0	2.0	5.0	12.0	1.83
49/40X10	40.0	10.0	2.0	5.0	12.0	3.01
49/50X10	50.0	10.0	2.0	5.0	12.0	3.82
49/60X10	60.0	10.0	2.5	6.0	16.0	4.45
49/60X12	60.0	12.0	2.5	6.0	16.0	5.50
49/60X20	60.0	20.0	3.0	6.0	16.0	9.15

Flight attachment options to Forged Chains.

T Type Attachments for Horizontal and Slightly Inclined Conveying

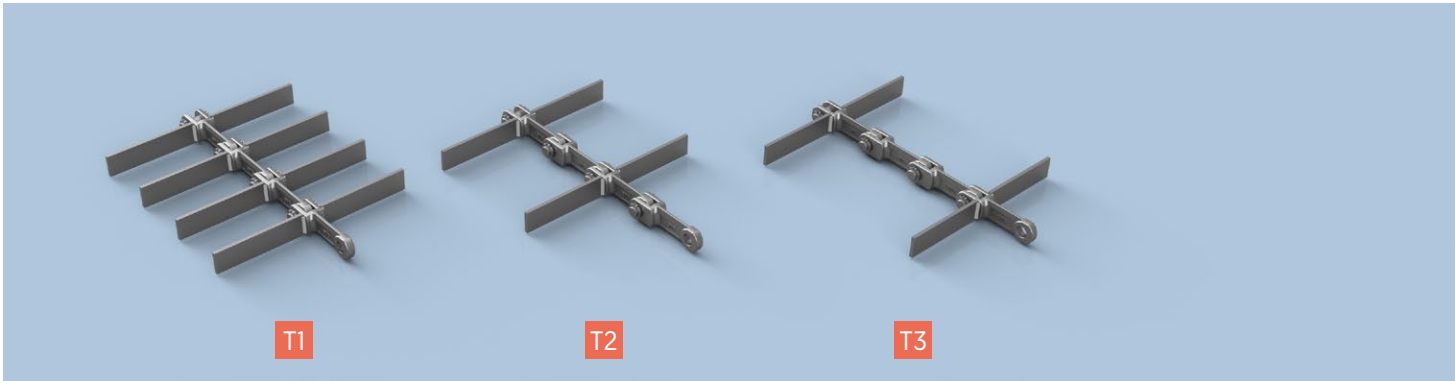

U Type Attachments for Horizontal and Inclined Conveying (with or without blanking plate)

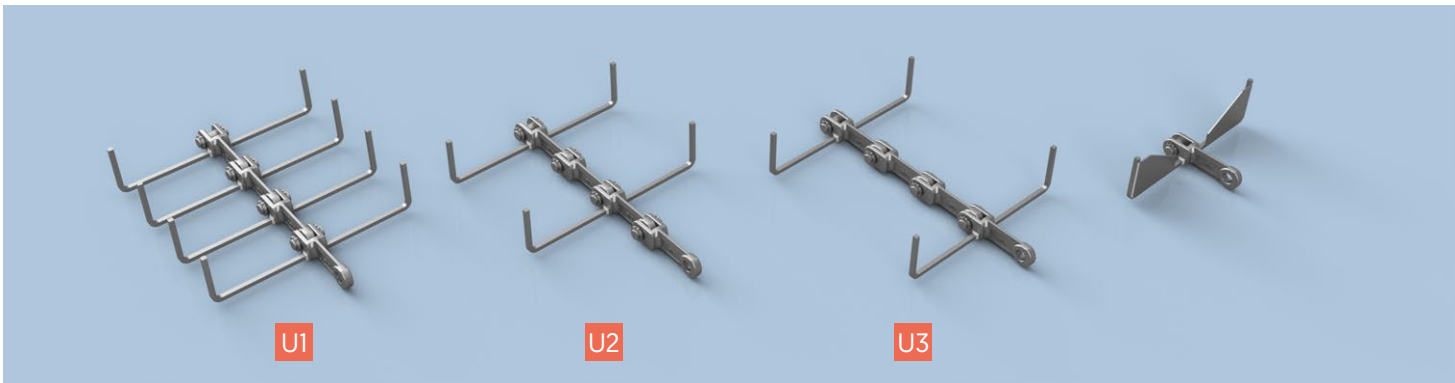

C Type Attachments for Horizontal, Inclined and Vertical Conveying (with or without blanking plate)

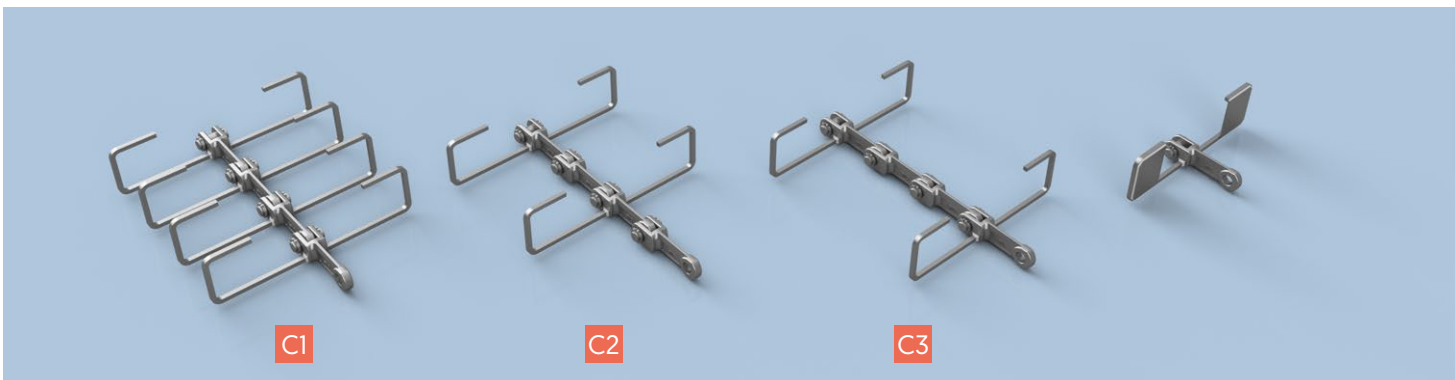

OO Type Attachments for Horizontal and Inclined Conveying (with or without blanking plate)

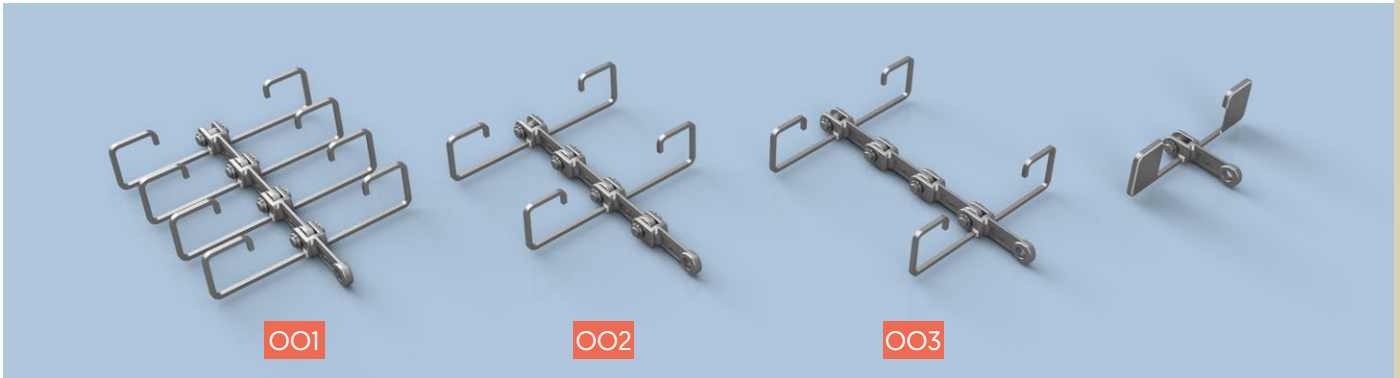

CO Type Attachments for Horizontal and Inclined Conveying (with or without blanking plate)

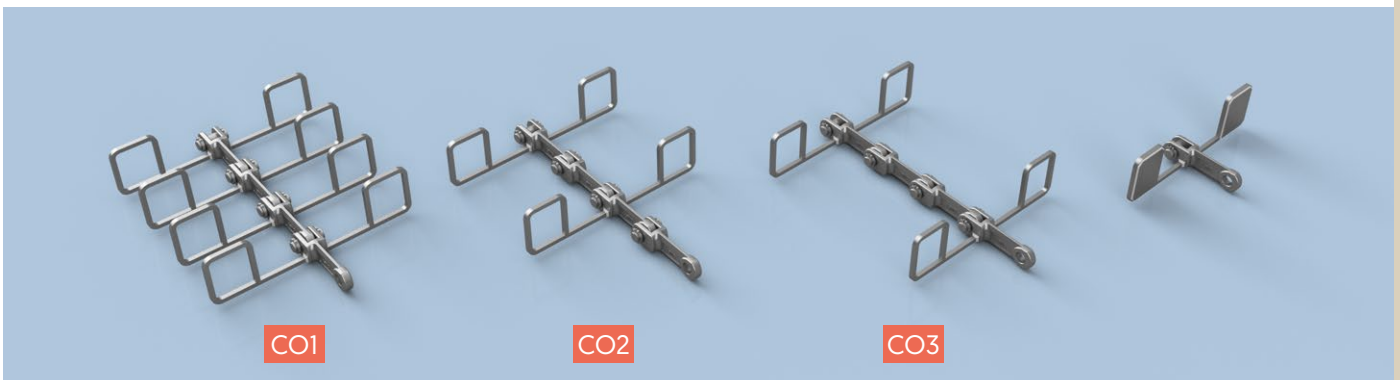

Double Series Flight Options I Format

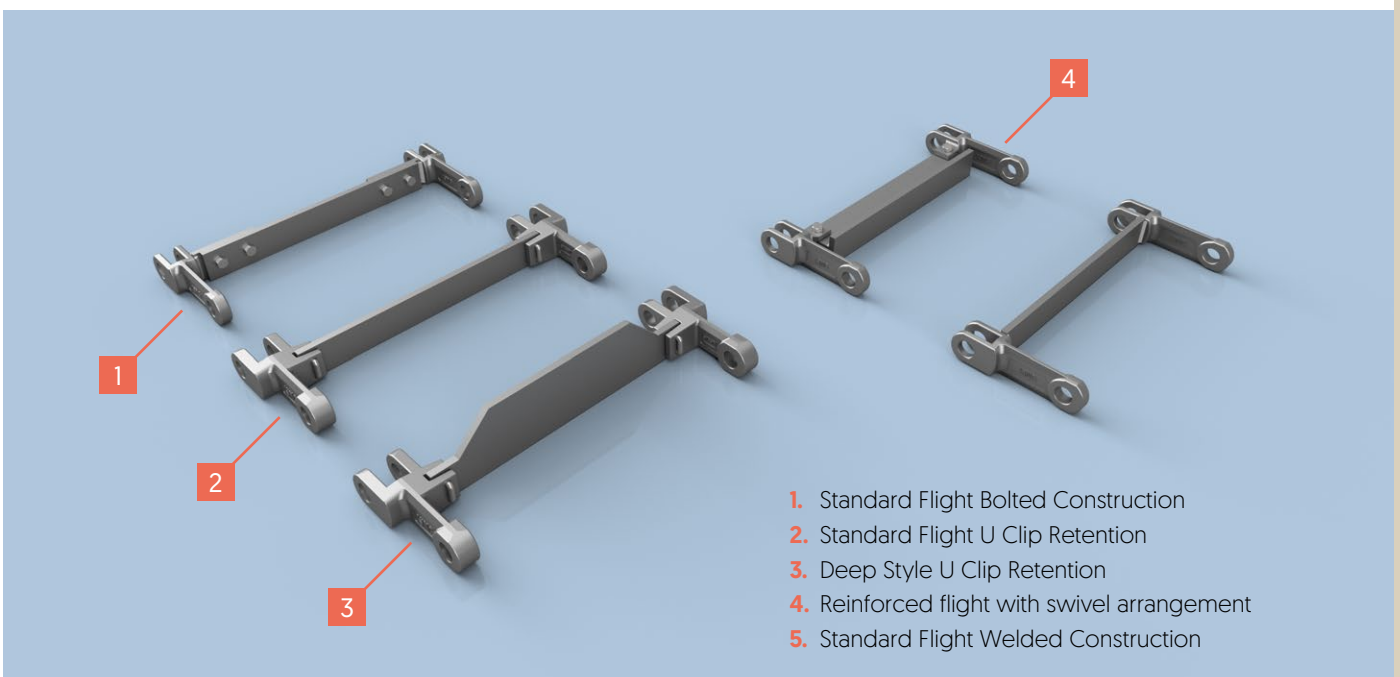



FM 77342
ISO 9001



Branches.

John King Chains USA Inc.

Birmingham, USA
Tel. +1 205 593 4279

John King Chains Central Europe Sp. z o.o.

Nakło nad Notecią, Poland
Tel. +48 600 871 077

Cadenas John King Ltda.

Concepción, Chile
Tel. +56 41 2214948

John King Chains (SA) (PTY) Ltd.

Boksburg, South Africa
Tel. +27 11 894 3570
Fax +27 11 894 3501

John King Chains Ltd Southern Office

Dursley, UK
Tel. +44 1453 543284

John King Chains Ltd.

Rosario, Argentina
Tel. +54 9 341 214 92 42

JOHN KING

Address

John King Chains Limited

New Climax Works,
Lancaster Business Park,
Sherburn-in-Elmet, LS25 6NS, UK

Phone & Fax

Phone: +44 1977 681 910
Fax: +44 1977 681 899

Online

Email 1: general@johnkingchains.co.uk
Email 2: sales@johnkingchains.co.uk

Website: www.johnkingchains.com