

Dealer's Manual

ROAD Wheel Set

WH-9000-C24-CL
WH-9000-C24-TL
WH-9000-C35-CL
WH-9000-C35-TU
WH-9000-C50-CL
WH-9000-C50-TU
WH-9000-C75-TU

WH-RS21
WH-RS61

CONTENTS

IMPORTANT NOTICE.....	3
TO ENSURE SAFETY.....	4
INSTALLATION	7
Tiresize	7
List of tools to be used	7
Cassette sprockets.....	7
Brake shoe setting position.....	8
MAINTENANCE	9
Spoke lacing	9
Replacing the spoke (WH-9000).....	10
Replacing the spoke (WH-RS61/RS21).....	15
Replacement of the freewheel body.....	18
Installing and removing tubeless tires.....	23

IMPORTANT NOTICE

- **This dealer's manual is intended primarily for use by professional bicycle mechanics.**

Users who are not professionally trained for bicycle assembly should not attempt to install the components themselves using the dealer's manuals.

If any part of the information on the manual is unclear to you, do not proceed with the installation. Instead, contact your place of purchase or a local bicycle dealer for their assistance.

- Make sure to read all instruction manuals included with the product.
- Do not disassemble or modify the product other than as stated in the information contained in this dealer's manual.
- All dealer's manuals and instruction manuals can be viewed on-line on our website (<http://si.shimano.com>).
- Please observe the appropriate rules and regulations of the country, state or region in which you conduct your business as a dealer.

For safety, be sure to read this dealer's manual thoroughly before use, and follow it for correct use.

The following instructions must be observed at all times in order to prevent personal injury and physical damage to equipment and surroundings.

The instructions are classified according to the degree of danger or damage which may occur if the product is used incorrectly.



DANGER

Failure to follow the instructions will result in death or serious injury.



WARNING

Failure to follow the instructions could result in death or serious injury.



CAUTION

Failure to follow the instructions could cause personal injury or physical damage to equipment and surroundings.

TO ENSURE SAFETY

WARNING

- **When installing components, be sure to follow the instructions that are given in the instruction manuals.**

It is recommended that you use only genuine Shimano parts. If parts such as bolts and nuts become loose or damaged, the bicycle may suddenly fall over, which may cause serious injury.

In addition, if adjustments are not carried out correctly, problems may occur, and the bicycle may suddenly fall over, which may cause serious injury.

-  Be sure to wear safety glasses or goggles to protect your eyes while performing maintenance tasks such as replacing parts.
- After reading the dealer's manual thoroughly, keep it in a safe place for later reference.

Be sure to also inform users of the following:

- Before use, check the wheels to make sure that there are no bent or loose spokes, dents, scratches or cracks on the rim surface. Do not use the wheel if any of these problems are found. The wheel may break, and you may fall. In the case of carbon wheels, check also that there is no carbon separation or cracking.
- If the quick release mechanism is not used correctly, the wheel may come off the bicycle and serious injury could result. Read the Service Instructions for the quick release mechanism thoroughly before use.
- These wheels are designed for riding on paved surfaces. If the wheels are used on unpaved surfaces, the wheels may become bent or damaged, and accidents may result.
- Check that the wheels are fastened securely before riding the bicycle. If the wheels are loose in any way, they may come off the bicycle and serious injury may result.

< Clincher wheel / Tubeless wheel >

- The hollow on the opposite side to the valve hole is an indicator for the amount of rim wear. If this hollow can no longer be seen, stop using the rim. If you continue using the rim, it may break, and the bicycle may fall over and an accident may result.

< Tubular wheel >

- Before riding, check if the tires are glued to the rims securely. If the tires come off while riding, you may fall and get severely injured.
- If the braking surfaces of the carbon fiber rims become extremely worn and the rims appear to have become deformed, stop riding the bicycle. If you continue to ride the bicycle in this condition, it may fall over and serious injury may occur as a result.

For Installation to the Bicycle, and Maintenance:

- Do not use in combination with bottom link-type suspension forks. With these types of forks, the clearance between the hub axle and the brake shoes can change due to the operation of the suspension, so that when the brakes are applied, the brake shoes may touch the spokes.

 **CAUTION**

Be sure to also inform users of the following:

- The tires should be inflated to the pressure indicated on the tires before use.

< C50/C75 wheel >

- Note that a higher rim is more affected by side winds and makes riding unstable.

< Clincher wheel >

- Use a high-pressure-resistant rim tape for a rim. Otherwise, a sudden puncture may occur, and you may fall off the bicycle.

< Tubeless wheel >

- Do not use rim tape. Rim tape may make it difficult to remove and install the tire, and the tire or tube may become damaged or the tires may suddenly puncture and come off, and severe injury may result.
- We do not recommend that you use general-purpose alkaline puncture repair agents, as they may cause the rims to corrode and allow air leaks to occur.

< Tubular wheel >

- Carbon fiber rims become worn due to friction from the brake shoes, and there may be a "run-in" period before the full performance of the rims can be obtained. As the run-in period progresses, the braking force will become stronger. You should take note of the increase in braking force during this time to ensure proper safety.

NOTE

Be sure to also inform users of the following:

- Before use, check that there are no pieces of metal or other foreign objects sticking to the brake pads. If any such items are present, they may cause damage to the rim when the brakes are applied.
- Do not apply any oil to the inside of the hub, otherwise the grease will come out.
- We recommend that you ask bicycle dealers to adjust the spoke tensions if there is any initial play in the spokes and after the first 1,000 km of riding.
- Spoke protectors are also sold separately. Check the model number on specifications and please ask your bicycle dealer for details.
- Reflectors (manufactured by CATEYE) are also sold separately. Please ask your bicycle dealer for details.

Model number	Specification	Color
RR-550-WUWSW	CPSC	White
RR-550-WUASW	AS	Amber
RR-317-WUASW	DIN	Amber

- Products are not guaranteed against natural wear and deterioration from normal use and aging.
- For maximum performance we highly recommend Shimano lubricants and maintenance products.

< Clincher wheel / Tubeless wheel >

- The Shimano R55HC (high performance) brake shoes use an aggressive compound designed with an emphasis on maximum performance in wet conditions, however they will cause accelerated rim wear. Shimano accepts no responsibility for reduced rim life which might occur from using R55HC brake shoes.

< Tubular wheel >

- Use R55C3 carbonfiber rim brake shoes with the Tubular wheel. If brake shoes such as the R55C standard shoes or R55C high-performance shoes are used, the braking force provided by the brakes may be insufficient, or the brake shoes may become abnormally worn. Shimano accepts no responsibility for reduced rim life which might occur from using R55HC brake shoes.
- Do not use an R55C3 carbon rim brake shoe which has already been used with an aluminum rim for a carbon rim again. Using the shoe on an aluminum rim will cause aluminum wear powder to be stuck on the brake shoe, which will damage the brake friction surface of the carbon rim.

For Installation to the Bicycle, and Maintenance:

- Be careful not to overtighten the nipples when adjusting the spoke tensions. If the nipples are overtightened, damage to the rim may result.
- If the wheel becomes stiff and difficult to turn, you should lubricate it with grease.
- Special nipple wrenches are available as optional accessories.

< Clincher wheel / Tubular wheel >

- Use of genuine Shimano spokes and nipples is strongly recommended. If non-Shimano parts are used, the area where the spokes fit into the hub unit may become damaged.

< Tubeless wheel >

- Use of genuine Shimano spokes and nipples is strongly recommended. If non-Shimano parts are used, the area where the spokes fit into the hub unit may become damaged.
- Use the rim-side plug to carry out truing and spoke tension adjustment.

The actual product may differ from the illustration because this manual is intended chiefly to explain the procedures for using the product.

INSTALLATION

■ Tire size

The recommended tire sizes for installation to each wheel are as follows.

model No.	Tire size
WH-9000-C24-CL	20c-25c
WH-9000-C24-TL	20c-25c
WH-9000-C35-CL	20c-25c
WH-9000-C35-TU	21mm-25mm
WH-9000-C50-CL	20c-25c
WH-9000-C50-TU	23mm-25mm
WH-9000-C75-TU	23mm-25mm

■ List of tools to be used

The following tools are needed to assemble this product.

Usage location	Tool
Lock ring	TL-LR15 / LR10

■ Cassette sprockets

For each sprocket, the surface that has the group mark should face outward and be positioned so that the wide parts of the gear projections on each sprocket and the A part (where the groove width is wide) of the freewheel body are aligned.

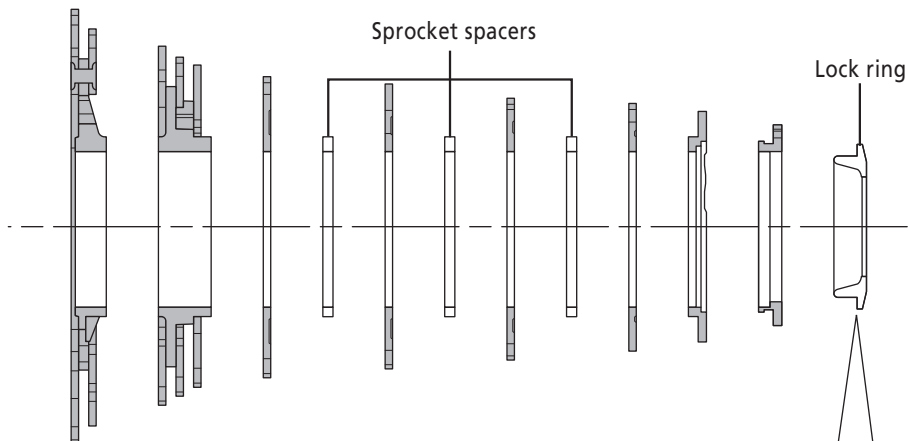
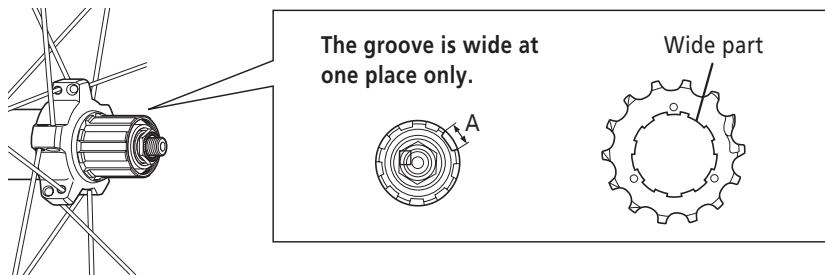

- For installation of the HG sprockets, use the special tool (TL-LR15) to tighten the lock ring.

Tightening torque:
30.0 - 50.0 N·m {262 - 437 in. lbs.}

- To replace the HG sprockets, use the special tool (TL-LR15) and TL-SR21 to remove the lock ring.

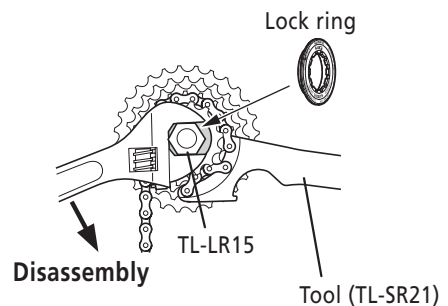

Note:

When installing a 10-step cassette other than CS-4600, install the included 1.85 mm low spacer and the 1.0 mm spacer included with the cassette at the positions indicated in the illustration.

For CS-4600, install only the 1.85-mm low spacer. (The 1.0 mm spacer is not necessary.)

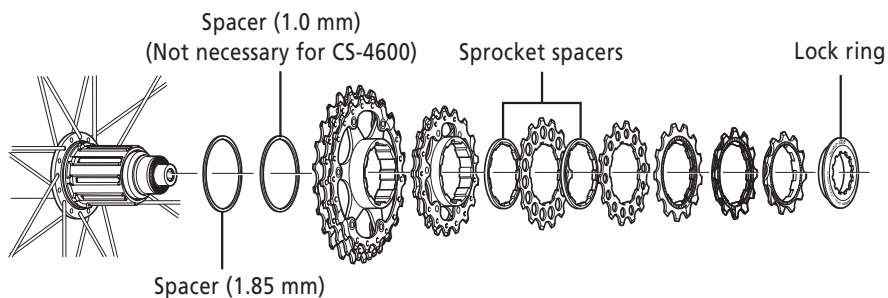

■ Brake shoe setting position

< WH-9000 >

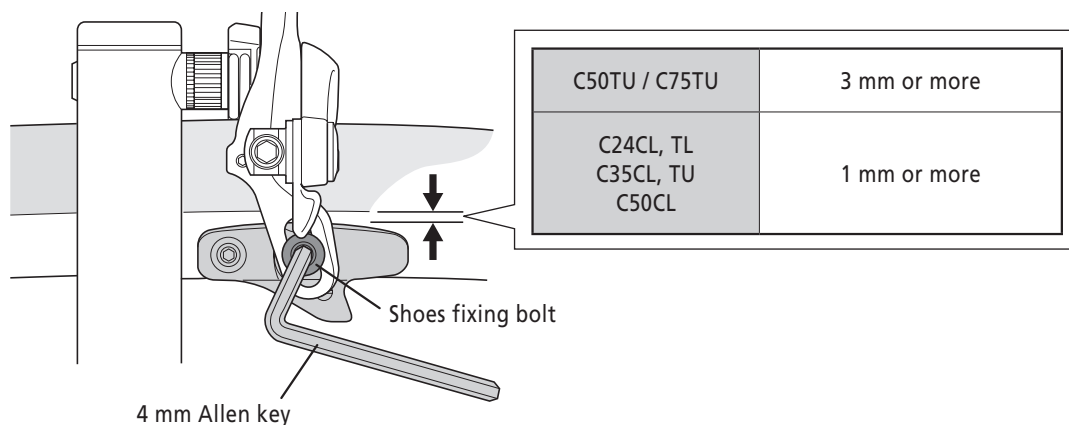

< WH-RS61, RS21 >

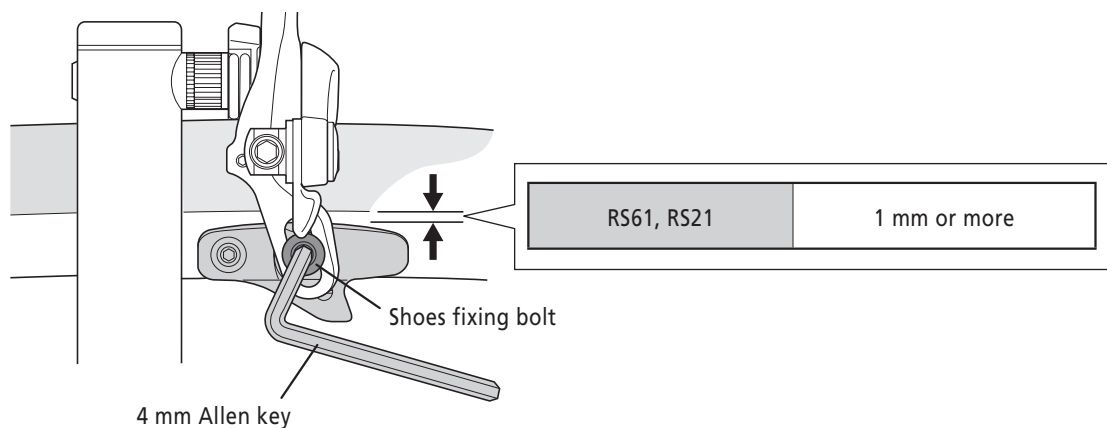

MAINTENANCE

Spoke lacing

Lace the spokes as shown in the illustration.

< Front >

At the front, a radial assembly is used at both the left and right.

< WH-9000-C24 / WH-RS21 / 61 >

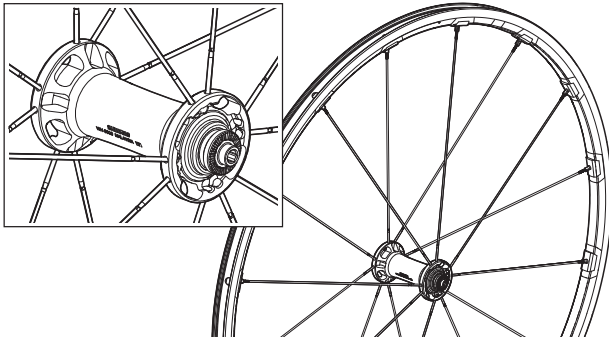

< WH-9000 C35, C50, C75 >

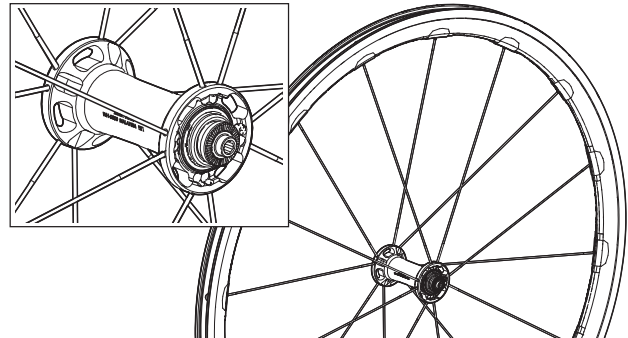

< Rear >

< WH-9000-C24 / WH-RS21 / 61 >

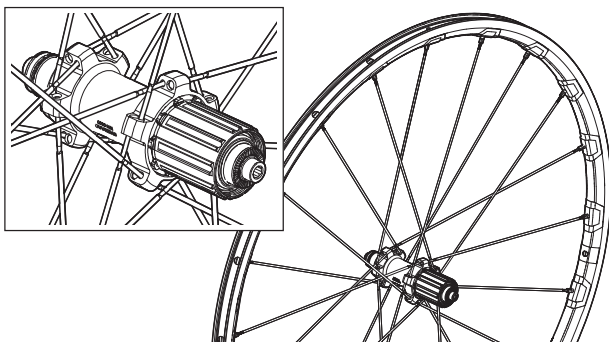

Both the left side and the right side are spoked tangentially.

< WH-9000 C35, C50, C75 >

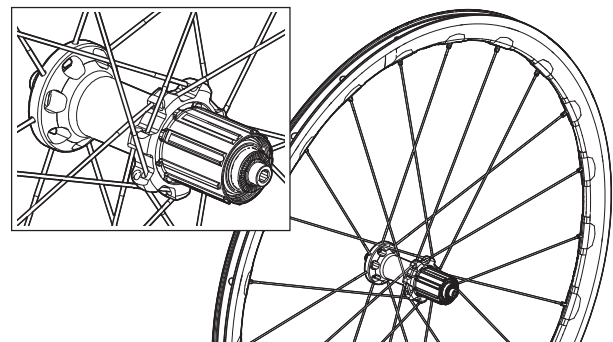

Right (gear) side: tangent spoke pattern
Left side: radial spoke pattern

Spoke tension value			
For front		For rear	
		Right (sprockets) side	Left side
C24	1000 - 1400 N (225 - 315 lbf)	1200 - 1500 N (270 - 337 lbf)	600 - 900 N (135 - 202 lbf)
C35			
RS21			
RS61			
C50	600 - 1000 N (135 - 225 lbf)	800 - 1100 N (180 - 247 lbf)	
C75		1000 - 1300 N (225 - 292 lbf)	

* These values should be used as a guide only.

■ Replacing the spoke (WH-9000)

When replacing the left-side spokes on the front and rear hubs, pull out the hub axle first.

- Follow the steps in the illustration to pull out the hub axle. Disassembly from the right side is not possible.

Pulling out a hub axle

< Front >

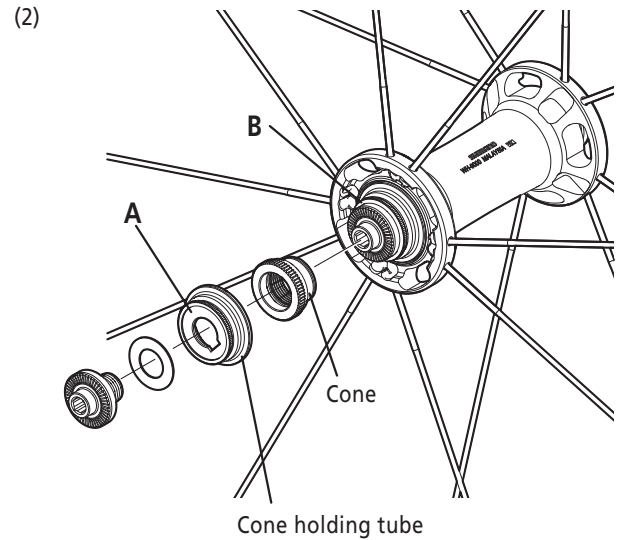
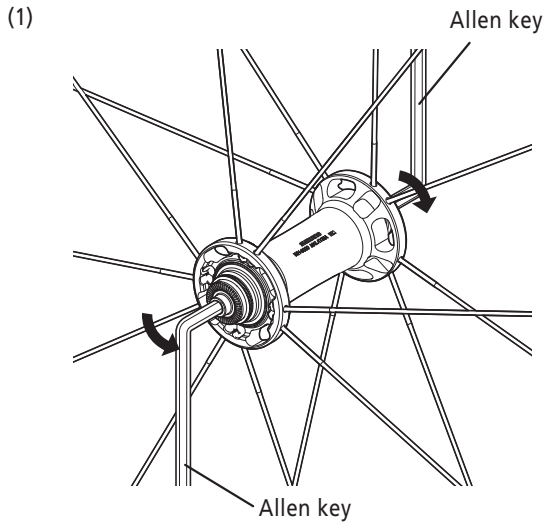

Tightening torque:
15.0 - 17.0 N·m {131 - 149 in. lbs.}

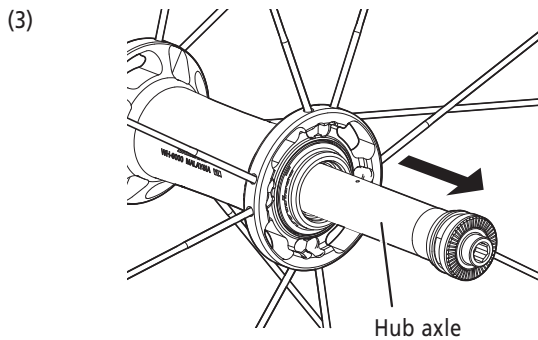

Note:

- When removing and installing the seal, do it very carefully so that the seal does not become bent. When reinstalling the seal, make sure that it is facing the right way, and insert it as far as it will go.
- Tighten the cone onto the hub axle until it has no looseness. While aligning the knurls of the cone and the knurls of the cone holding tube, align section A of the cone holding tube with section B on the hub axle.

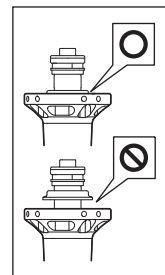

< Rear >

- First, pull out the hub axle by following the procedure shown in the illustration. Disassembly from the freewheel side is not possible.

(1)

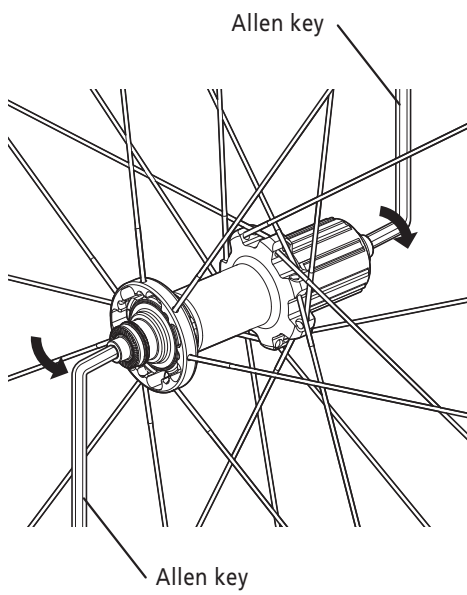

(2)

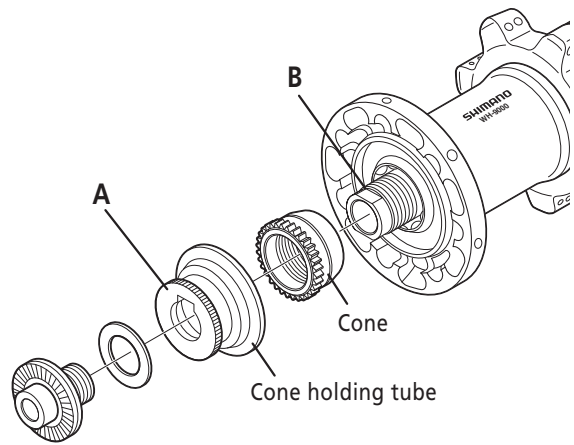

Tightening torque:
15.0 - 17.0 N·m {131 - 149 in. lbs.}

(3)

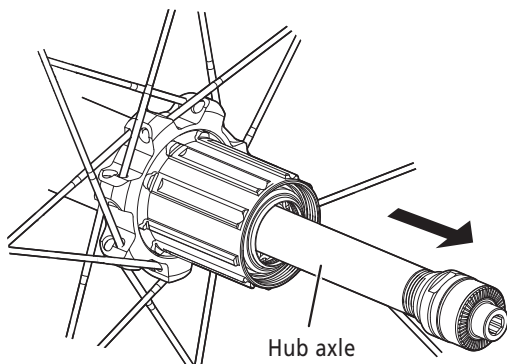

Note:

- When removing and installing the seal, do it very carefully so that the seal does not become bent. When reinstalling the seal, make sure that it is facing the right way, and insert it as far as it will go.
 - Tighten the cone onto the hub axle until it has no looseness. While aligning the knurls of the cone and the knurls of the cone holding tube, align section A of the cone holding tube with section B on the hub axle.
- When assembling the spokes, reverse the procedure.

Replacing front spokes

< C24-CL/C35-CL/C35-TU/C50-CL/C50-TU/C75-TU >

Hook the spokes through the hub as shown in the illustration to install them.

Right side

Left side

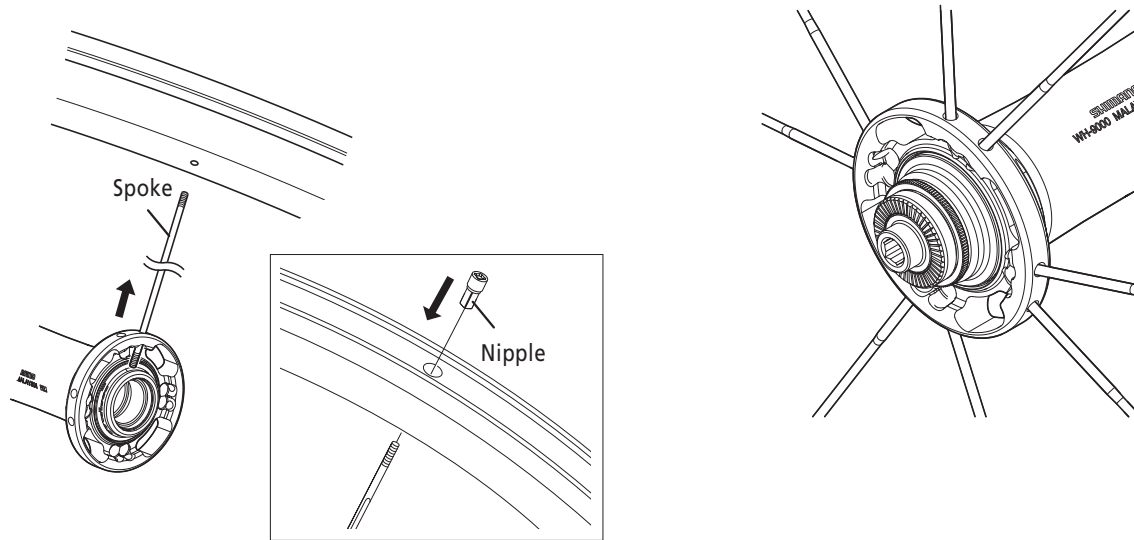

< C24-TL >

1. Pass the washer and plug over the spoke.
2. After inserting the spoke into the hole in the hub flange, tighten the nut. When installing, use the spoke plug wrench to secure the spoke so that it does not turn, and then insert a screwdriver or similar tool into the groove in the nut to screw in the nut.

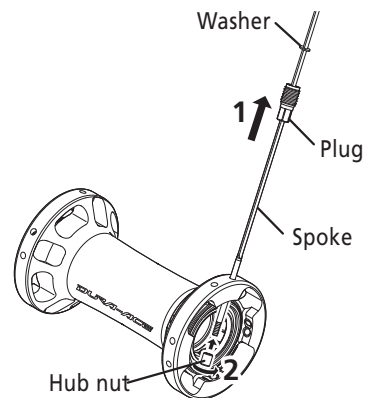

3. Turn the plug clockwise to screw it into the screw hole in the rim. At this time, use the spoke plug wrench to stop the spoke from turning.

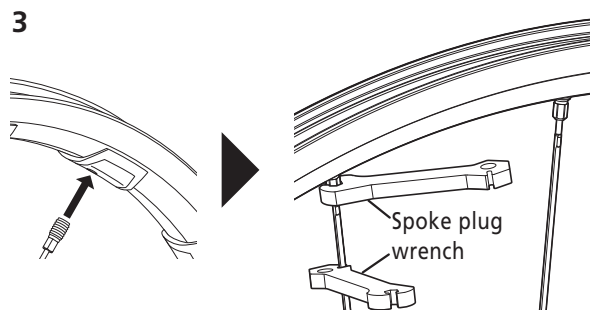

Note:

- If the washer is not installed, it will not be possible to adjust the spoke tension, so be sure to include the washer.
- Tighten the nut as far as the edges of the thread.

Replacing rear spokes

The right-side spokes can be replaced without removing the hub axle.

< C24-CL/C35-CL/C35-TU/C50-CL/C50-TU/C75-TU >

Precautions for replacing right-side spokes

When replacing a right-side spoke on the rear hub, slightly push the adjacent spokes before removal.
Do the same when you put a spoke through.

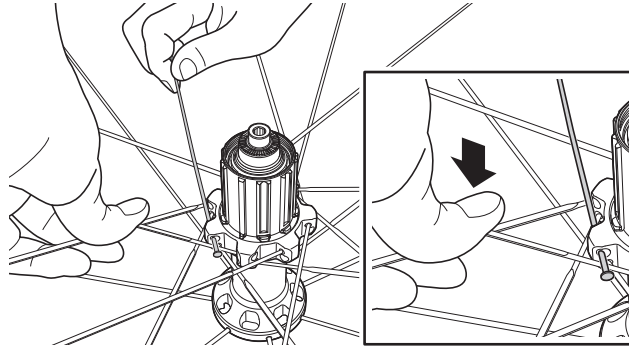

< C24-CL >

Hook the spokes through the hub as shown in the illustration to install them.

Right side

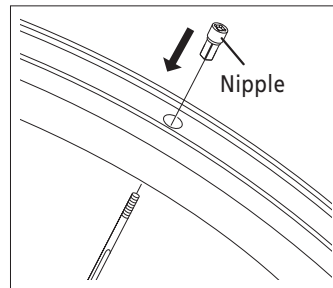
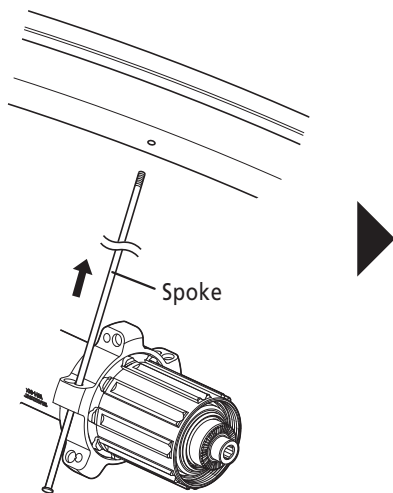

Left side

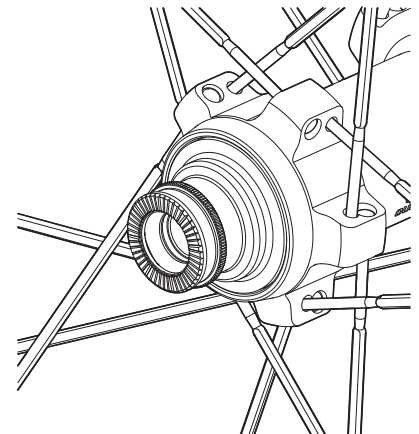

< C35-CL/C35-TU/C50-CL/C50-TU/C75-TU >

Hook the spokes through the hub as shown in the illustration to install them.

Right side

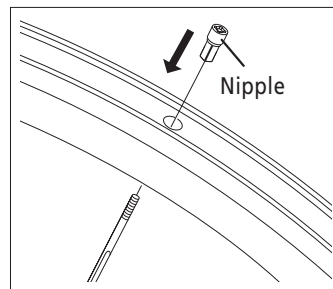
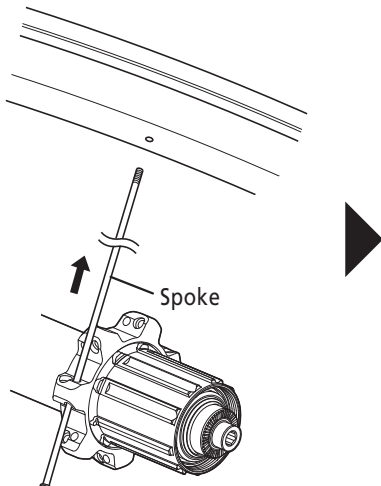

Left side

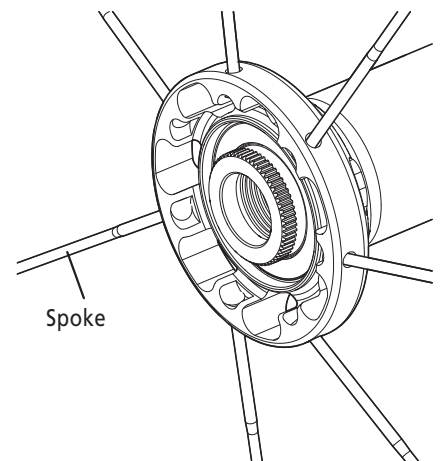

< C24-TL >

Hook the spokes through the hub as shown in the illustration to install them.

1. Pass the washer and plug over the spoke.
2. After inserting the spoke into the hole in the hub flange, tighten the nut. When installing, use the spoke plug wrench to secure the spoke so that it does not turn, and then insert a screwdriver or similar tool into the groove in the nut to screw in the nut.
3. Turn the plug clockwise to screw it into the screw hole in the rim.
At this time, use the spoke plug wrench to stop the spoke from turning.

Right side

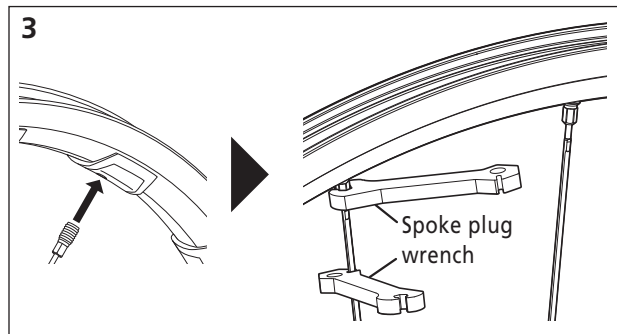
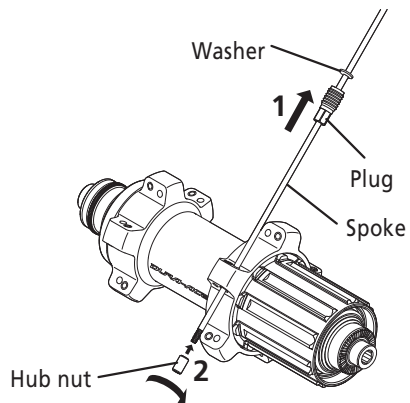

Left side

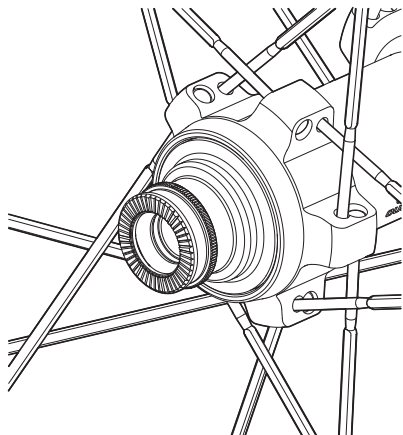

Note:

- If the washer is not installed, it will not be possible to adjust the spoke tension, so be sure to include the washer.
- Tighten the nut as far as the edges of the thread.

■ Replacing the spoke (WH-RS61/RS21)

< WH-RS61 >

1. Use the pliers to cut the spoke to remove it.

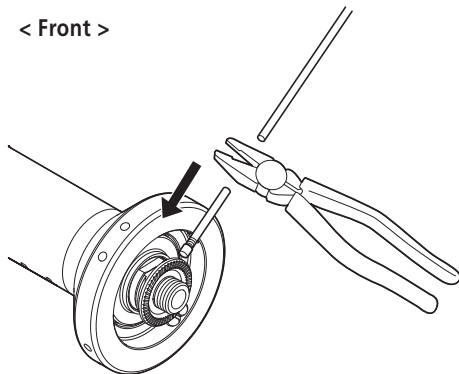

2. Pass the spoke through the hub and install the hub nut.

< Front >

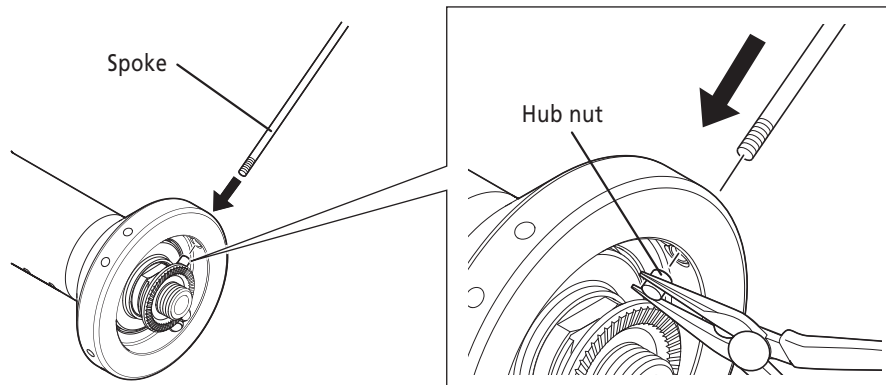

< Rear >

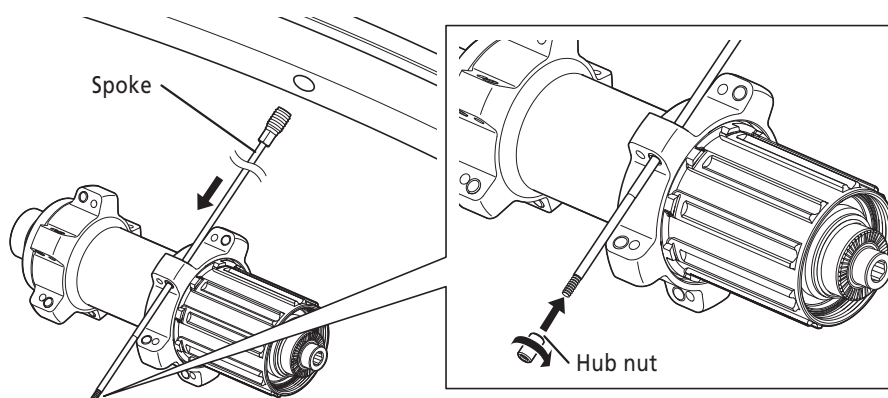

3. Hit the rim lightly to align the rim nut with the spoke hole position.

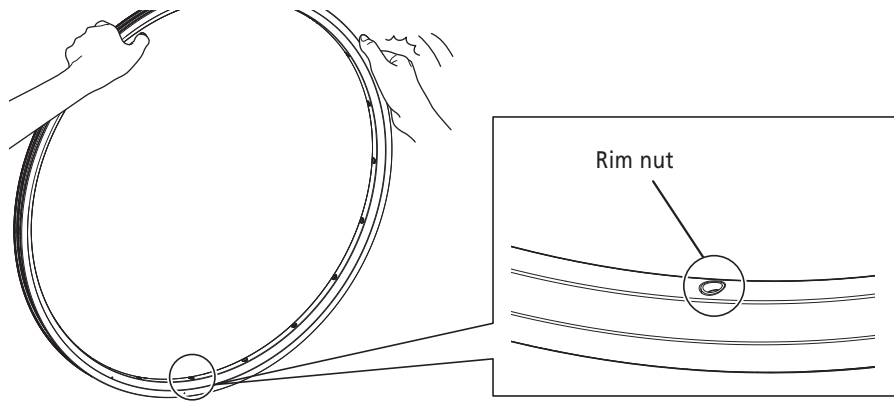

4. After confirming that a spoke can be passed into the rim hole, temporarily tighten the spoke plug.

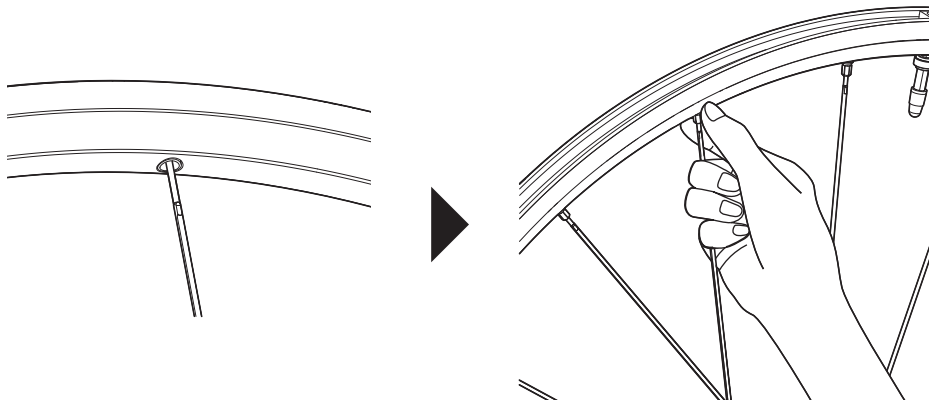

5. Tighten the spoke plug with the included wrench.

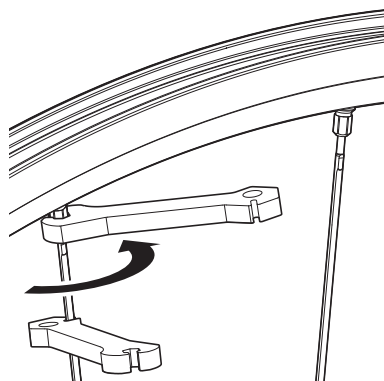

< WH-RS21 >

< Front >

To prevent the front side from being damaged, set the spoke head completely into the groove in the hub body.

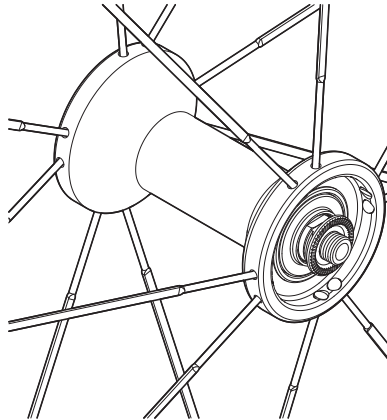

< Rear >

Hook the spokes through the hub as shown in the illustration to install them.

Right side

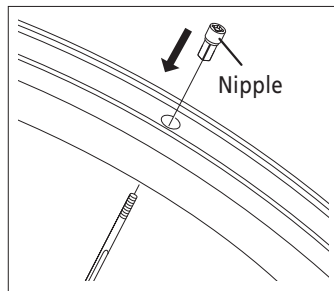
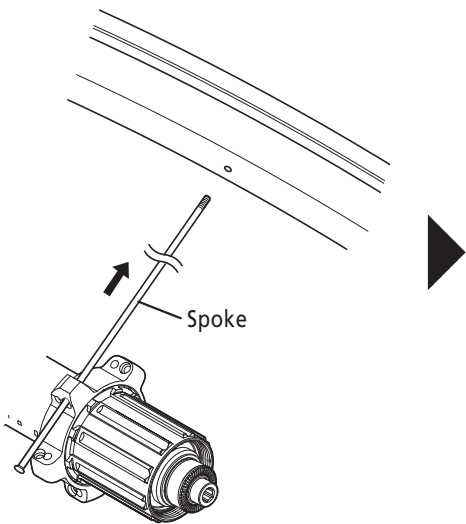

Left side

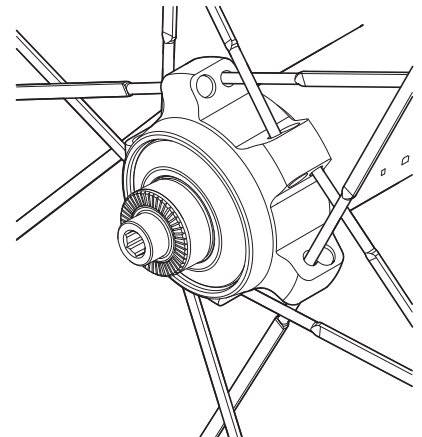

Pull out the hub axle by following the procedure shown in the illustration.
Disassembly from the right side is not possible.

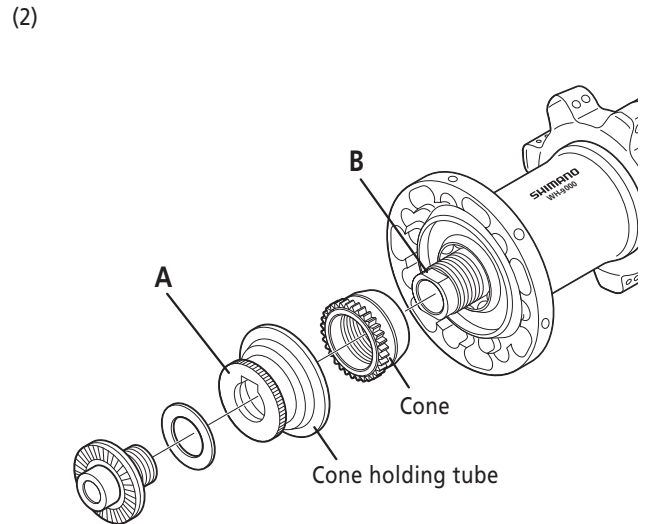
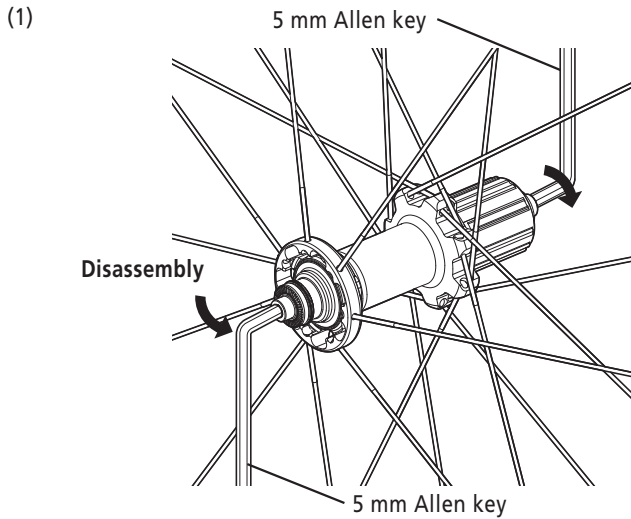

Tightening torque:
15.0 - 17.0 N·m {131 - 149 in. lbs.}

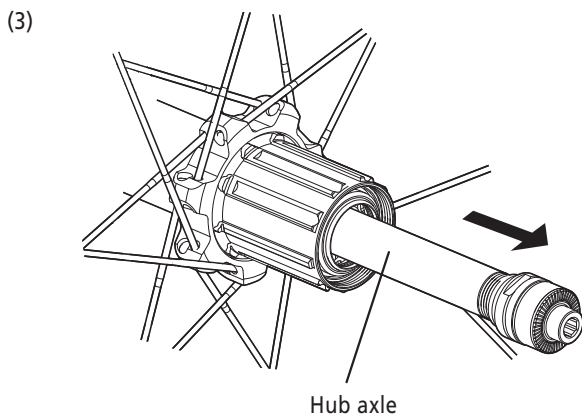

Note:

- When removing and installing the seal, do it very carefully so that the seal does not become bent. When reinstalling the seal, make sure that it is facing the right way, and insert it as far as it will go.
- Tighten the cone onto the hub axle until it has no looseness. While aligning the knurls of the cone and the knurls of the cone holding tube, align section A of the cone holding tube with section B on the hub axle.

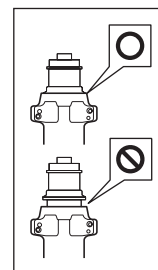

After removing the hub axle, remove the freewheel body fixing bolt (inside the freewheel body), and then replace the freewheel body.

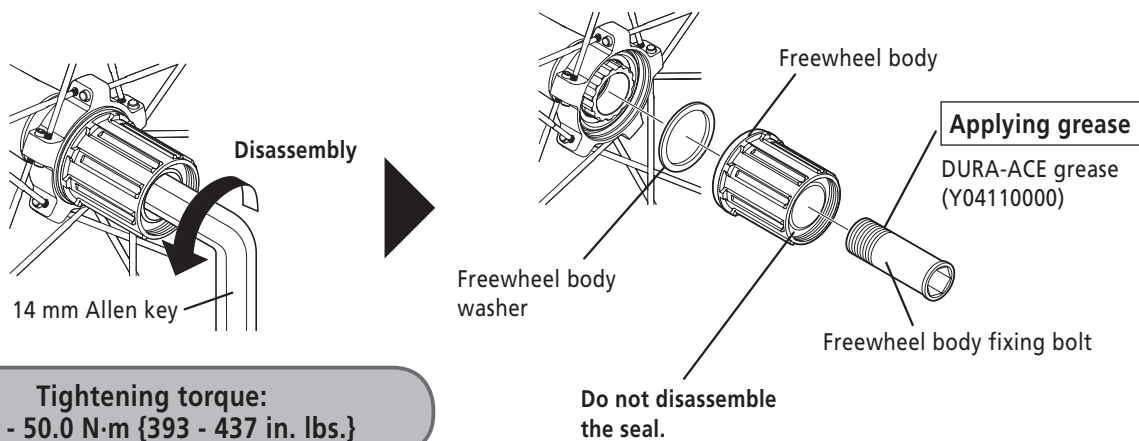

Tightening torque:
45.0 - 50.0 N·m {393 - 437 in. lbs.}

Note:

When replacing the freewheel body, replace the freewheel body fixing bolt at the same time. Be sure to apply grease to the the thread of the freewheel body fixing bolt, otherwise looseness or sticking may occur.

Do not disassemble the freewheel or apply oil or grease to it, otherwise problems with operation may occur.

Pulling out a hub axle

(1)

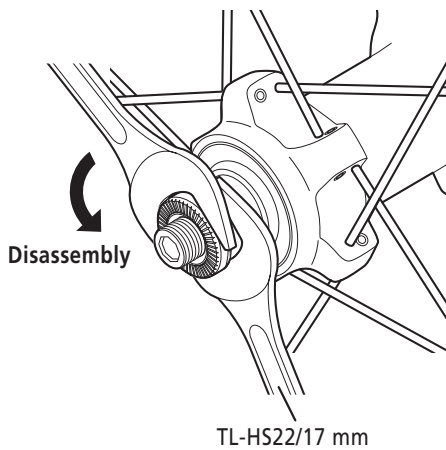

(2)

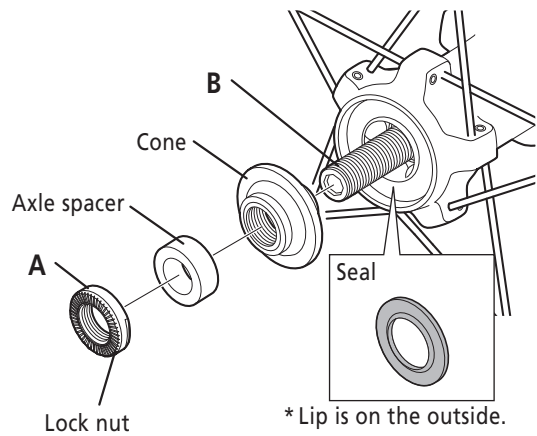

Tightening torque:
15.0 - 17.0 N·m {131 - 149 in. lbs.}

(3)

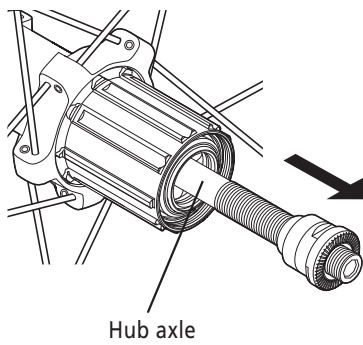

Note:

- When removing and installing the seal, do it very carefully so that the seal does not become bent. When reinstalling the seal, make sure that it is facing the right way, and insert it as far as it will go.
- Tighten the cone onto the hub axle until it has no looseness. While aligning the knurls of the cone and the knurls of the cone holding tube, align section A of the cone holding tube with section B on the hub axle.

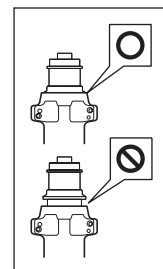

After removing the hub axle, remove the freewheel body fixing bolt (inside the freewheel body), and then replace the freewheel body.

Note:

Do not attempt to disassemble the freewheel body, because it may result in a malfunction.

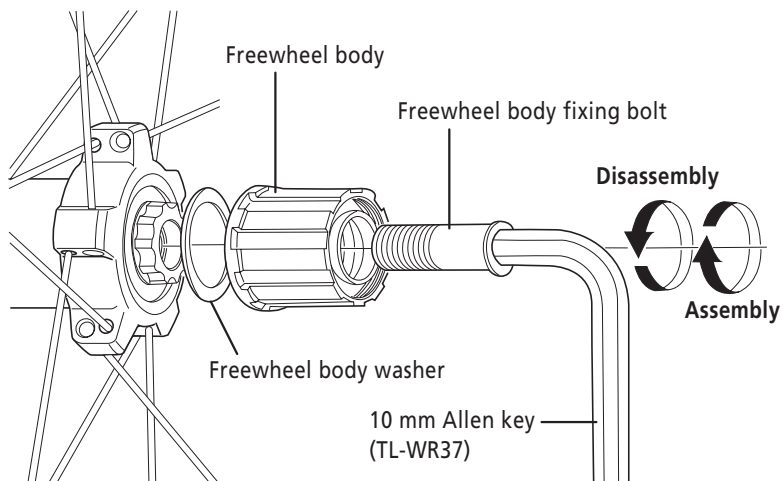

Tightening torque:
35.0 - 50.0 N·m {305 - 435 in. lbs.}

■ Installing and removing tubeless tires

TO ENSURE SAFETY

⚠ WARNING

- Read these Technical Service Instructions carefully, and keep them in a safe place for later reference.

⚠ CAUTION

- Do not use rim tape if using an inner tube either. Rim tape may make it difficult to remove and install the tire, and the tire or tube may become damaged or the tires may suddenly puncture and come off, and severe injury may result.

Note

- The tires should always be installed and removed by hand. Never use tools such as tire levers, as they can damage the seal between the tires and the rims and cause air to leak out from the tires.
- Do not tighten the valve nut too much, otherwise the valve seal may become warped and air leaks may occur.
- If the tires are difficult to fit, use plain water or soapy water to help them slide more easily.
- Products are not guaranteed against natural wear and deterioration from normal use and aging.

Technical Service Instructions

1. Installing tubeless tire valves

- Install the valve so that it faces as shown in the illustration.

When tightening the valve nut, check that the valve does not turn together with the valve nut.

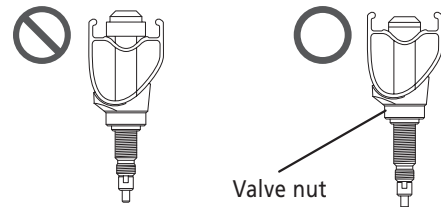

2. Installing the tires

- Insert the bead on one side of the tire as shown in the illustration.

Check that there are no foreign particles in the tire bead, rim and valve at this time.

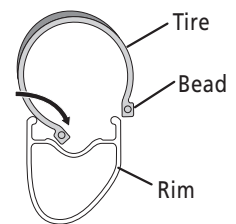

- Insert the bead on the other side of the tire starting from the point opposite the air valve.

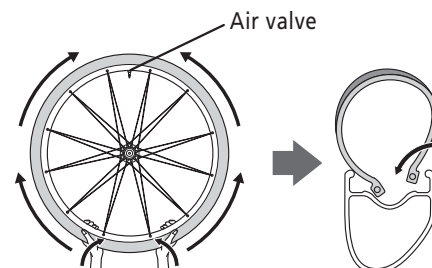

It will become more difficult to insert the bead at the side of the air valve. In such cases, lift up the bead by hand starting from the opposite side of the tire, and work your way around to the location of the air valve.

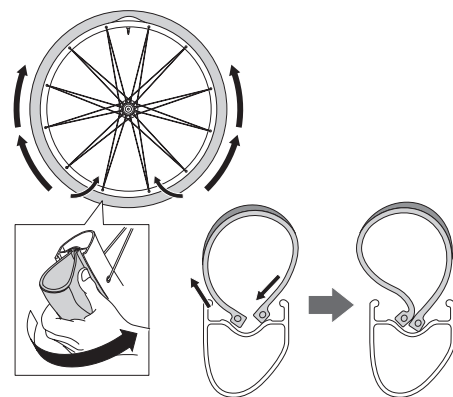

Lastly, grip the tire with both hands as shown in the illustration and insert the tire into the rim.

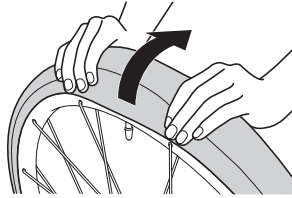

Inflate with air to lock the beads of the tires into the rim as shown in the illustration.

After this, deflate the tire and check that the bead is locked into the rim.

Then re-inflate the tire to the standard air pressure for use.

If the bead is not locked into the rim, the bead is separating from the rim when the tire is deflated.

(Max : 800kPa/116psi)

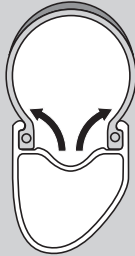

3. Removing the tires

- To remove a tire, deflate the tire and then push the bead on one side of the tire into the gorge of the rim as shown in the illustration.

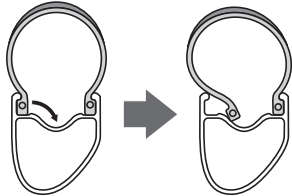

Note:

Be sure to only push in the bead on one side of the tire. If you push the beads in on both sides, the tires will be difficult to remove. If you push in the beads on both sides, inflate the tire once more to lock the beads, and then remove the tire by starting the procedure from the beginning again.

- Remove the bead on one side of the tire starting from the point closest to the air valve, and then remove the bead on the other side of the tire.

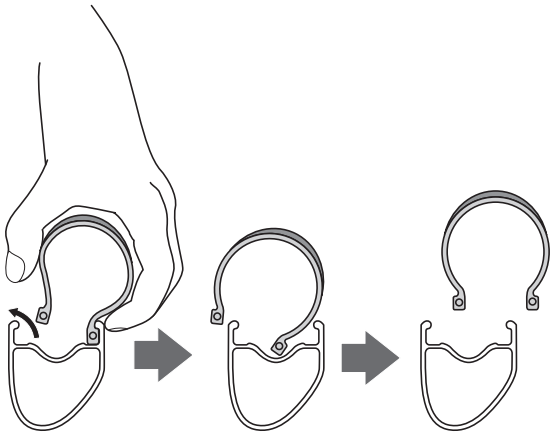

4. Notes when using inner tubes

- Loosen the locking ring of the air valve and remove the air valve.
- Insert the bead on one side of the tire as shown in the illustration.



- Liberalily moisten the outer edges of the rim and the tire beads, and place the slightly-inflated inner tube inside the tire so that it can slide smoothly.
- Check that the air valve of the inner tube is appropriate for use with the rim.
- Insert the bead on one side of the tire starting from the side of the rim opposite the air valve. Be careful not to pinch the tube at this time. If necessary, use soapy water.
- Inflate the inner tube until the tire locks into place.
- Contact your dealer for the specifications of inner tubes that can be used.

SHIMANO

SHIMANO AMERICAN CORPORATION

One Holland, Irvine, California 92618, U.S.A. Phone: +1-949-951-5003

SHIMANO EUROPE B.V.

Industrieweg 24, 8071 CT Nunspeet, The Netherlands Phone: +31-341-272222

SHIMANO INC.

3-77 Oimatsu-cho, Sakai-ku, Sakai-shi, Osaka 590-8577, Japan

Please note: specifications are subject to change for improvement without notice. (English)

© Sep. 2012 by Shimano Inc. HTR