

**A short manual for  
operation, installation, mounting and programming**

## **Door intercom system TFS-Dialog 200**

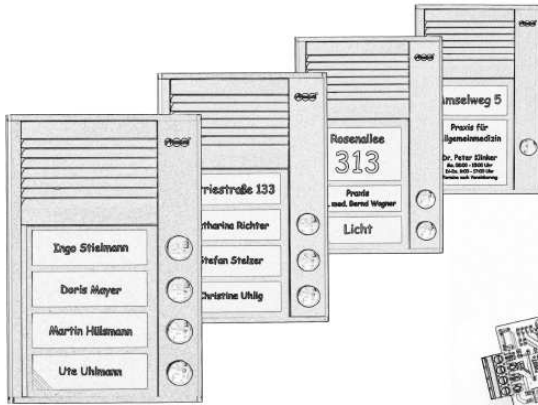

**TFS-Dialog 201**

**TFS-Dialog 202**

**TFS-Dialog 203**

**TFS-Dialog 204**

**a/b-Schaltmodul**



### **Contents**

Security Advice .....	2
Scope of Supply .....	2
Overview .....	3
Open the housing .....	3
Closing the housing .....	6
Labelling the name plates .....	8
Programming .....	9
Analog switch modules .....	12
Connection diagrams .....	14

#### **General limitation of legal responsibility and application**

Auerswald products are not designed or intended for use in any life-saving and/or life support application and/or nuclear facility. When using our products for such applications a written agreement by Auerswald for each individual case is necessary in advance.

#### **Copyright**

Passing on or duplicating the contents of this manual or parts of it is only allowed with our express written permission. Offenders will be subject to claims for damages. All Rights Reserved.  
© Auerswald GmbH & Co. KG, 38162 Cremlingen, 2007

## Security Advice



**Warning** *Touching the voltage carrying conductors or the telephone connections may cause an electric shock **dangerous to life**.*



**Warning** *Liquids entering the case may cause an electric shock **dangerous to life**.*

- Pay attention when **selecting the installation location** and when **cleaning the case** to prevent liquids from entering the case.



**Warning** *Touching defective connection cables may cause an electric shock **dangerous to life**. Damages to the case and the device itself may also be dangerous to life.*

- The mains cables of the electric devices and the connection cables must regularly be **checked** for damages. If you discover damages, the concerning cables must be **replaced**.
- **Replace damaged components** (e.g. components of the case) immediately.
- Use **original components only**. Otherwise the device may be damaged or security and EMC regulations may be violated.
- **Repairs may be made by a specialist only**. Talk to your authorized dealer or to the vendor directly.



**Attention** *Surge voltages e.g. generated by a thunderstorm and liquids entering the case, may damage or destroy the device.*

- Protect the components by installing an **over-voltage protection device**.
- Pay attention when **selecting the installation location** and when **cleaning** the case to prevent liquids from entering the case.
- All cables – also those to the door terminal system – must be **placed inside the building**.



**Important** *Mechanical loads and electromagnetic fields may influence the operation of the device.*

- Please **avoid mechanical stress** (e.g. vibrations) and the close neighbourhood to devices that radiate **electromagnetic fields** or interfere with these units (e.g. radios, HAM-radio installations, mobile telephones, DECT base stations, etc.).



**Warning** *Surge voltages e.g. generated by a thunderstorm, may cause an electric shock **dangerous to life**.*

- Therefore **do not install** the device during a thunderstorm. Also do not work on cable connections during a thunderstorm.
- All cables – also those to the door terminal system – must be **placed inside the building**.



**Attention** *Exceeding (even for a short time) the limits stated in the technical data may cause **considerable damages**.*

- Observe the **limits** stated in the technical data concerning voltage, current, power consumption, operating temperature and humidity.



**Attention** *Some components are sensitive against **electrostatic discharge** and can be destroyed by it.*

- **Discharge yourself** before touching the printed circuit boards with your hands or with tools. Touch a grounded bare metal surface like a radiator or PC case.

## Care instructions



### ATTENTION

*The surface can be damaged by detergents. Please do not use aggressive or solvent based detergents.*



### NOTE

*The device is weatherproof and does not need additional care. When dirty please clean the device using a damp cloth.*

## Scope of supply

- Base unit TFS-Dialog 200 (201 – 204 depending on model)
- Complete manual (German)
- This short manual (English)
- Labelling stripes
- Mounting material for wall mounting
- Special key for opening the housing

## TFS-Dialog 200 overview

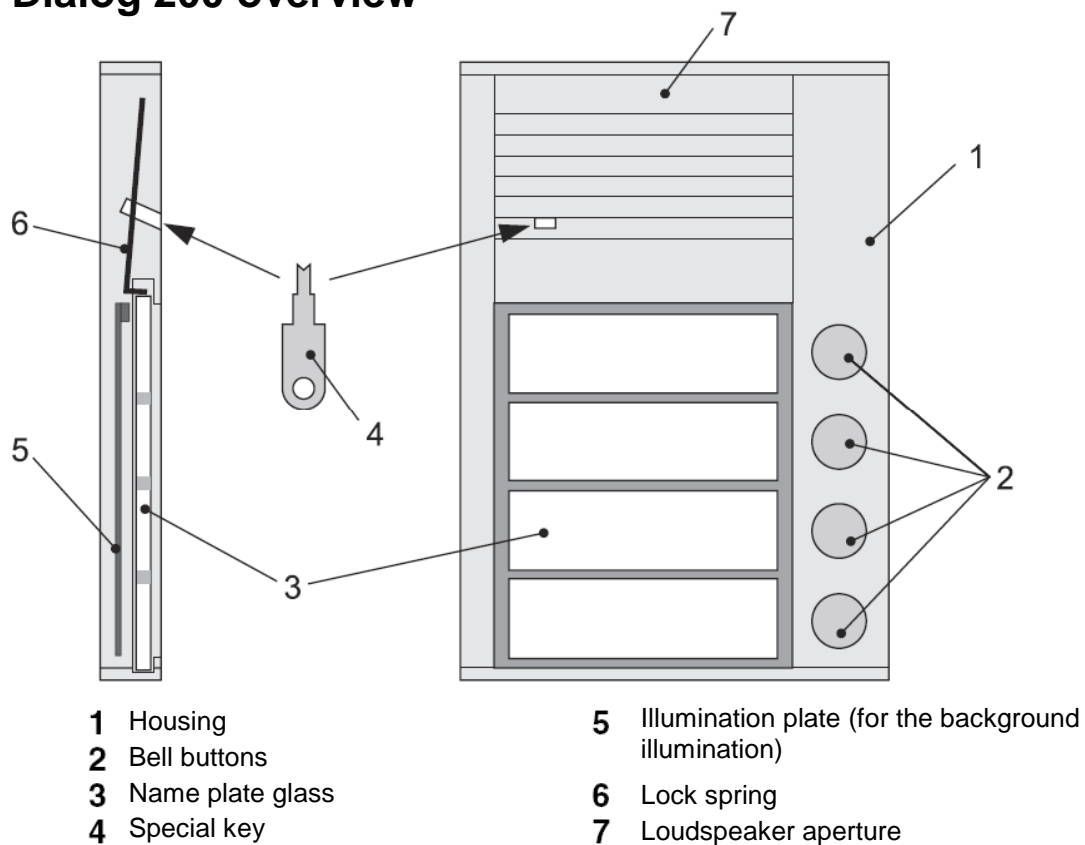

### Open the housing



**WARNING!**

**Danger of electric shock.**

- Please disconnect the connection to the analog port of the PBX and to the ringing transformer **BEFORE** opening the housing.



**CAUTION!**

**Possible damage due to wrong handling.**

- Please follow the steps mentioned below.

- 1 Push the special key (4) into the small opening in the loudspeaker aperture.
- 2 Press the key in the direction (A) against the force of the spring to the stop and hold it.
- 3 Push the name plate (3) with slight force into direction (B) until it comes out of the profile
- 4 Pull the key out of the hole.

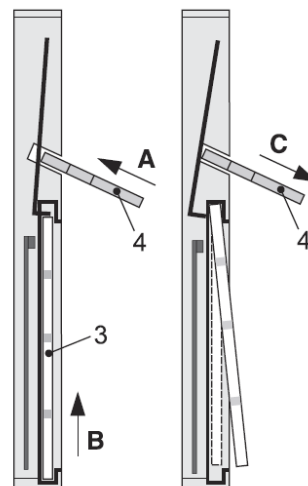

## Installation and mounting

- 5 Take out the name plate in direction **(D)**.
- 6 Pull out the name plate to the bottom in direction **(E)**.

Now the glass of the name plate is removed and can be labelled as described later.

For the next mounting and installation steps the illumination plate for the background illumination has to be taken out.

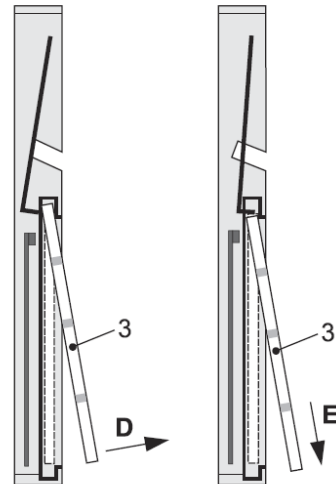

### CAUTION!

**Possible damage of the illumination panel with the loudspeaker blind.**

- It is mandatory to remove the illumination plate out of the housing.

- 7 Release the illumination plate with the special key by pressing on the spring in direction **(F)**.

Please observe: it is connected with a cable!

- 8 Take out the illumination plate
- 9 Pull out the connector in direction **(G)**.

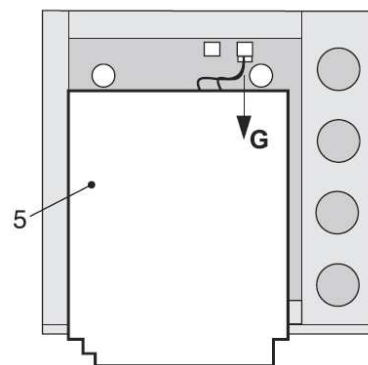
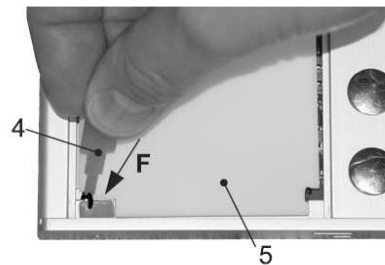

## Installation and mounting

10 Pull the loudspeaker blind in direction **(H)**.

Cable connectors: **8**

Holes for mounting: **9**

Hole for cabling: **10**

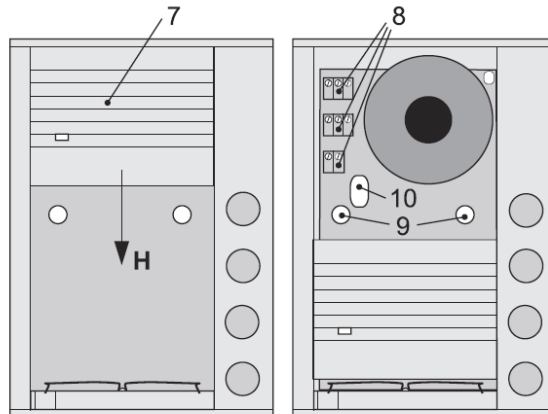

A description of the cable connectors you can find at the end of the manual.

### Mounting on the wall

#### WARNING!

*Fluids intruding into the housing may lead to a **perilous electric shock** or to the **damage or destruction** of this device.*

- Please observe when choosing the mounting location that this device is **not** exposed to direct rainfall.
- Do **not** mount this unit on free-standing objects which are not protected against rainfall.

*Before mounting the housing of TFS-Dialog 200 is to be opened (see also "Open the housing").*

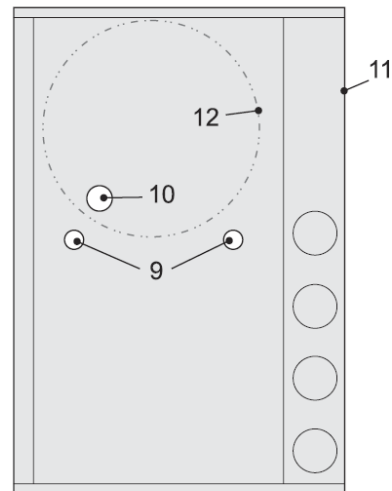

The housing (11) can be fixed to the wall with two screws using the holes (9).

For the storage of reserve cabling a flush mount socket can be used optionally (like indicated in the drawing above).

## Installation and mounting

### Mounting with a weather protection

The weather protection (13) available as an accessory will be fixed to the wall with two screws using the screw holes (14). For the marking of the drilling holes you can use the weather protection. The mounting material is included.

The mounting of the TFS-Dialog 200 will be made using the fixation holes (9) of the weather protection and screws.

#### WARNING!

**Fluids intruding into the housing** may lead to a **perilous electric shock** or to the **damage or destruction** of this device.

- Please observe when choosing the mounting location that this device is **not** exposed to direct rainfall.
- Do **not** mount this unit on free-standing objects which are not protected against rainfall.

Before mounting the housing of TFS-Dialog 200 is to be opened (see also "Open the housing").

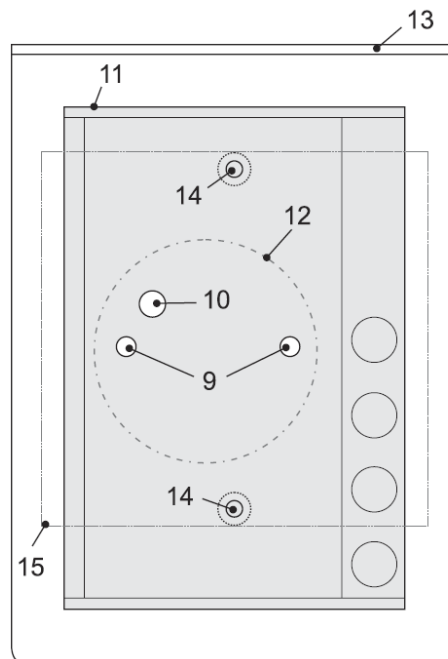

For the storage of reserve cabling a flush mount socket can be used optionally (like indicated in the drawing above).

### Closing the housing



#### CAUTION!

Possible damage of the loudspeaker when moving up the loudspeaker blind incorrect

- Please act as mentioned below.

- 1 Press down the loudspeaker gently a little bit in direction (L) and hold it.
- 2 Push the loudspeaker aperture up to the upper end in direction (M).
- 3 Connect the plug of the lighting plate with the base board in direction (N).

By choosing the according connector the operation mode of the power supply matching the implemented connection will be set.

- For **power supply using the analog port** please use the right connector (marked with a/b)
- For **power supply using a ringing transformer** please use the left connector (marked  $\simeq$ ).

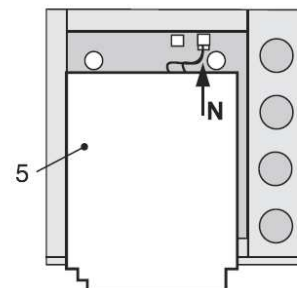
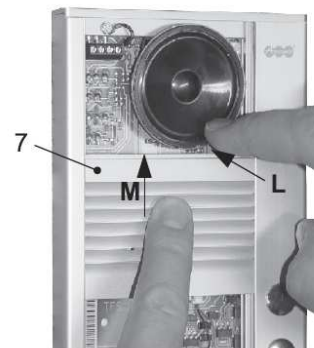

#### NOTE

With a connected lighting plate the TFS-Dialog is permanently occupying the analog port to get the necessary power. In that case it is not possible to call the door phone.

## Installation and mounting



### Important

Please observe that all cables are stored below the illumination plate.

platte

- 9 Put the lighting plate with its upper end first into the housing.
  - 10 Press down the lower end in a way that it is safely fixed between the two ends of the spring.
- Please observe the correct position of the cut-outs at the low end of the plate!

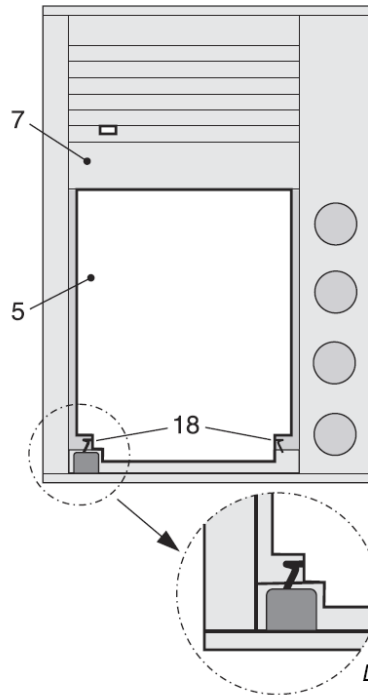

### Hint

Should the illumination plate slide out of the holding springs during further mounting please fix it again in a correct way because otherwise an optimal illumination cannot be guaranteed..

- 4 Press down the lighting plate with slight pressure in direction **(O)** and hold it.
- 5 Place the name plate in the slide rail on the two sides while holding the lighting plate.
- 6 Slide the name plate in direction **(P)** under the loudspeaker aperture until it stops and hold it in direction **(R)**.

Please observe: do not push the lighting plate out of its hold when pushing up the name plate!

- 7 Release the lighting plate – it is fixed now.
- 8 Push the special key into its hole and press down the spring in direction **(Q)**.

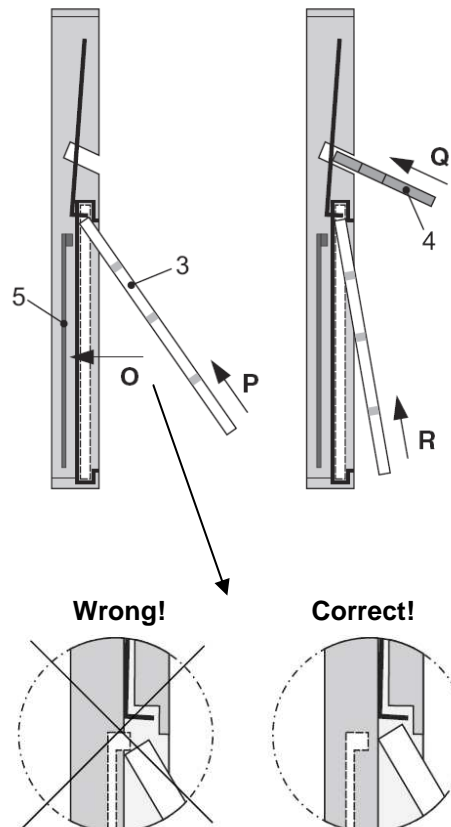

- 11 Now you can push the name plate further up in direction **(R)**.
- 12 Pull out the special key in direction **(S)**.
- 13 Press the name plate down in direction **(T)** against the springs until it stops.
- 14 Slide the name in direction **(U)** into the profile until it locks in place audible.

Now the door phone is usable.

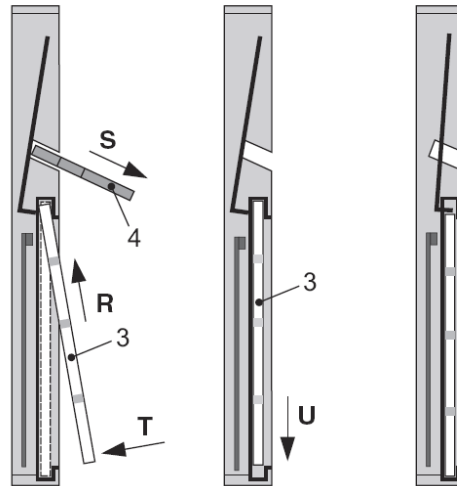

### Labelling and inserting of the name plates

- 1 Open the housing using the special key and take out the name plate glass **(3)**.
- 2 Label the name plates **(17)** directly with a pen or use the print templates you can find on [www.auerswald.de](http://www.auerswald.de) under „Service ... Download ... Handbücher ... Zubehör“
- 3 Insert the finished plates into the slots **(16)** at the back of the name plate glass in the direction **(K)**.



#### HINT

*If the edges of the slots are too tight to the glass you can open the slots by pressing slightly towards the middle with both thumbs. To take out the labels you could use tweezers.*

- 4 Insert the name plate glass **(3)** as described above.

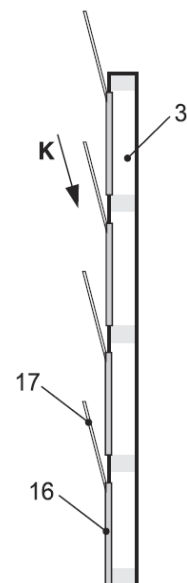



## Start the programming



Press any bell button (you will hear a tone) and hold it for approx. 5 seconds until a second signal tone can be heard.

**Within 3 minutes:**  
Pick up the handset of one of the internal telephones

Dial the internal number of the TFS-Dialog 200 – the connection is established.

## Execute the programming

First programming or after a programming break of more than 3 minutes



Dial star.



Short tone.

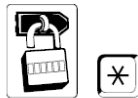

Input PIN and close with star



Wait for the end of the tones (five short tones)



Dial the programming code of the desired function.



Wait for the end of the acknowledgement tone

## Additional programming



Dial star.



Wait for the end of the acknowledgement tone



Dial the programming code of the desired function.



Wait for the end of the acknowledgement tone



### Hint

You can make more than one programming one after the other without putting the handset back. Exceptions are described. Correct input will lead the acknowledgement tone (six tones). Wrong input will give an occupied signal for 1-2 seconds. Start again with star (\*).

For protection please set a PIN. At subsequent programming the PIN must not be entered again. The programming mode ends 3 minutes after the last programming or when a bell button is pressed.

**Allocation of numbers to the bell buttons 1 -4 (default: 31 – 34)**

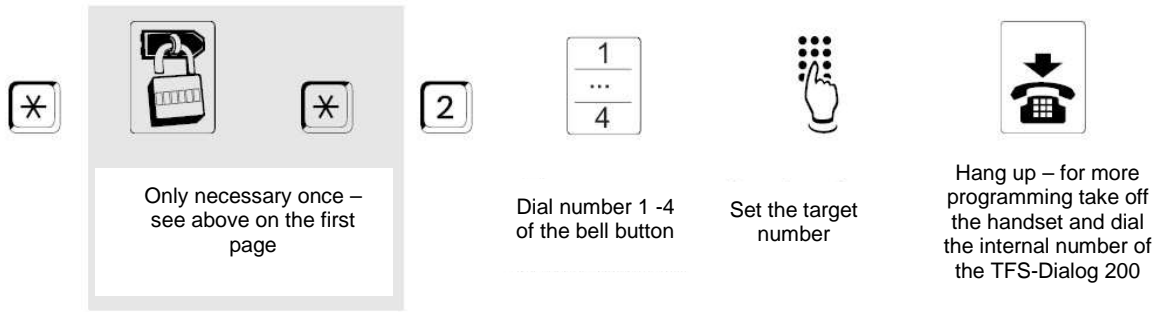

**Allocation of switching frequencies to the bell buttons 1 -4 (default: 1 – 4)**



**Allocation of additional door bells to the bell buttons 1 -4 (default: 1, 2, 0, 0)**

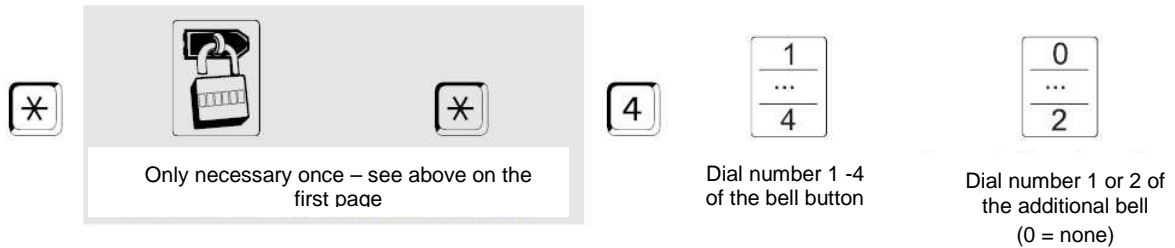

**Setting of the switching time for lighting (default: 0,5 sec.)**

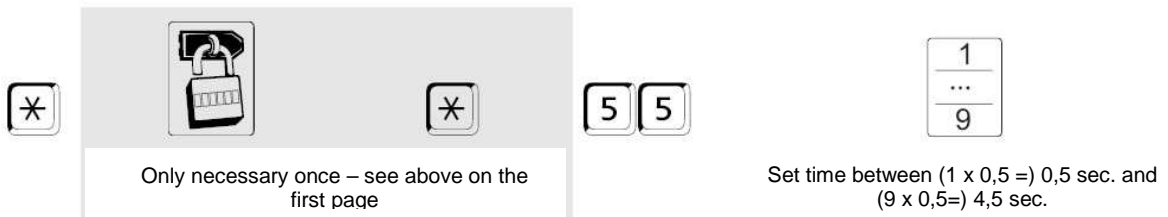

**Switching on the light during a door call (default number: 8)**



Will be activated from the phone by dialling # + above set digits

**Setting the time for the door opener (default: 2 sec.)**

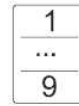
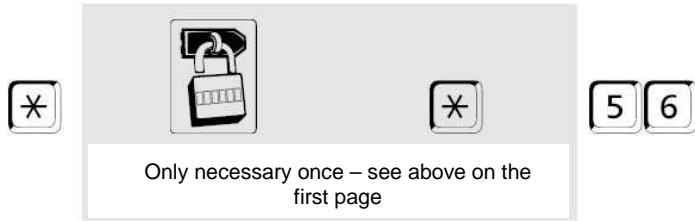

Set time between (1 x 0,5 =) 0,5 sec. and (9 x 0,5=) 4,5 sec.

**Opening the door during the call (default number: 9)**

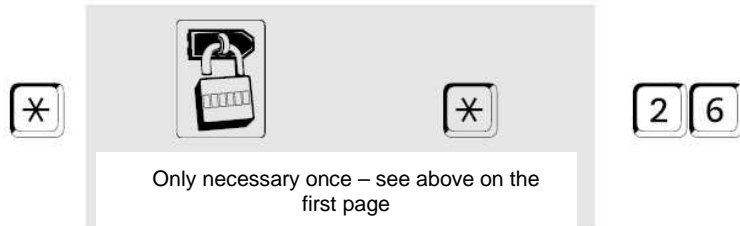

Any series of digits possible (1-6 digits)

Will be activated from the phone by dialling # + digits

**Setting of the input sensitivity (default:1)**

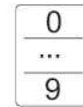
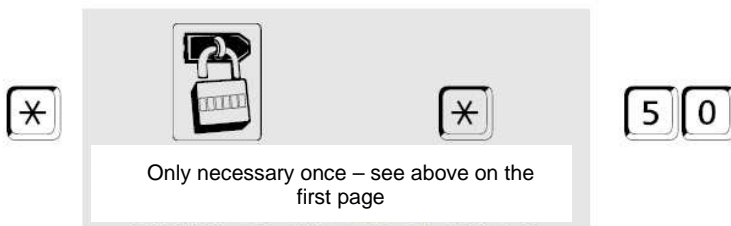

Set the input sensitivity between low (1) and high (9)

**Setting the environment sound level (default number: silent)**

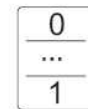
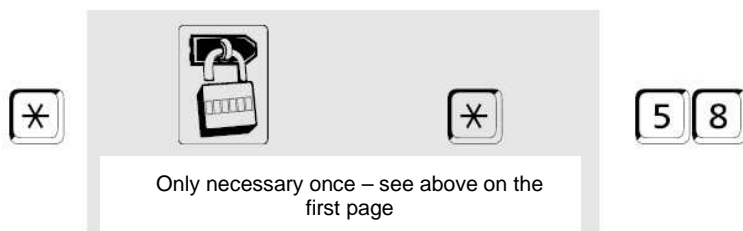

Set silent (0) or loud (1)

**Setting the volume of the loudspeaker (default: 6)**

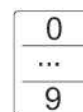
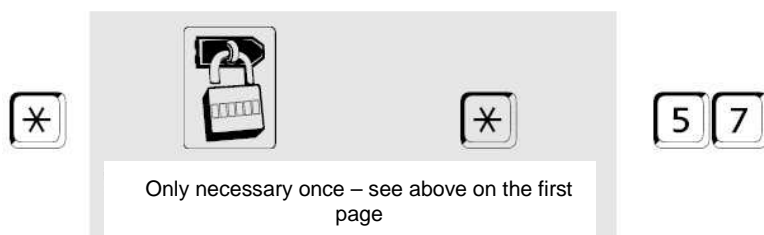

Set the volume between low (0) and high (9).

## Reset to factory settings

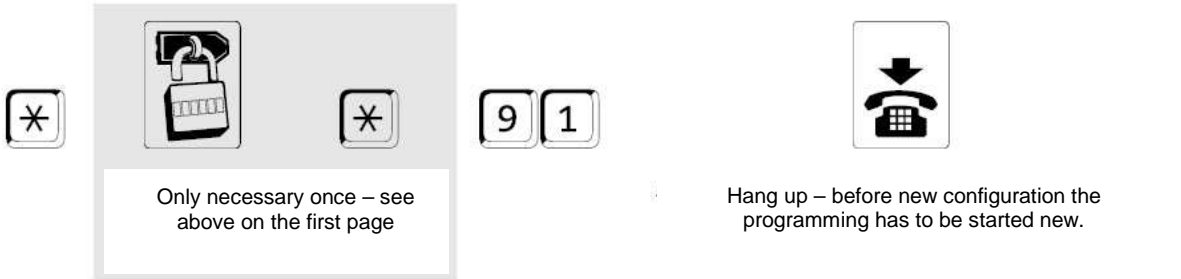

## Change of the PIN (default: 0000)



## A short intro to: a/b Switching Modules

It has six switching frequencies: No. 1 - 4 are related to bell buttons on the TFS-Dialog 200 with free allocation. The other two can be used for door opening (No. 6) and light (No. 5) controlled by the telephone which is doing the door call by dialling of certain numbers.

Please observe: the a/b switching modules are not made for 230 V!! For this you would have to use a matching relay in between. The switching lasts for 1 to 4,5 seconds - if you need a longer time (e.g. staircase lighting) you will need a time relay. For some installations with high internal resistance (e.g. staircase lighting) the included resistor has to be connected parallel (see picture page 24 - top right corner).

You can set the switching frequencies like this:

\* PIN \* 3 (number of button 1 - 4) (number of frequency 1 - 4)

Example: \*0000\*312 (button 1 (the top button) activates switching frequency 2)

How to start the programming see above.

Door opening is: \* PIN \* 56 (time 1 = 0,5 sec. - 9 = 4,5 sec.)

example: \*0000\*564 (for 2 sec. of door opener)

... and you will have to switch the module itself to "5" with the DIP switch.

## Expansion of the installation with a/b switching modules

### Basic parts a/b switching module

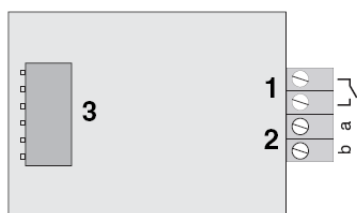

- 1 Connection for the device that should be switched
- 2 Connection to the two-wire line parallel to the TFS-Dialog 200 and the internal analog port.
- 3 DIL switch

The TFS-Dialog 200 can be expanded with the optional a/b switching modules to get more switching functions (e.g. switching of additional door bells, a second door opener or a stairway lighting) not having to install additional lines to the TFS-Dialog 200.

An a/b switching module switches on the connected device only when a signal in a certain frequency has been sent via the line. In total up to six different switching frequencies are available which can be controlled by using the integrated DIL switch.

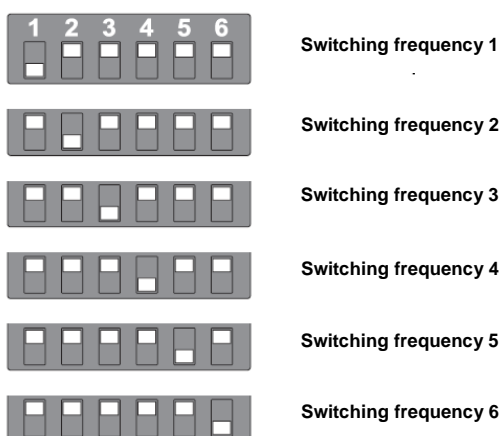

**Four** switching frequencies (frequency 1 to 4) are meant for the door bells 1 to 4 and can be allocated to these buttons freely.

**Two** additional switching frequencies can be used for door opening (frequency 6) or

for lighting control (frequency 5).

The control of both functions (door opener and light) is done with the telephone which has the door call at that time and is executed by dialling a certain sequence of digits.

Only the lighting control can be executed additionally by one or all bell buttons.



#### NOTE!

The a/b switching modules are not made for the direct connection of 230 V mains!

- For the switching of 230 V devices an additional relay circuit has to be used.



#### IMPORTANT!

The a/b switching can hold the switching mode only for 1 to 4,5 seconds!

- If longer times are necessary please use a time relay like a staircase light controller.



**HINT!**

Alternatively to the door bell buttons you can use the switching frequencies 1 to 4 during a door call (e.g. for the switching of a second staircase light controller). The control is done with the telephone which has the door call at that time and is executed by dialling a certain sequence of digits.

How to connect this:

- For this case every a/b switching module comes with an additional resistor which can be connected to the electronic door bell or a staircase light controller to guarantee a minimal standby current for the feeding of the module..

1. Connect the a/b switching modules with the clamps named **a** and **b** to the line between the TFS-Dialog 200 and the internal analog port.
2. Connect the device which should be switched and the power supply to the other two clamps.

### Control of additional door bells with a/b switching modules

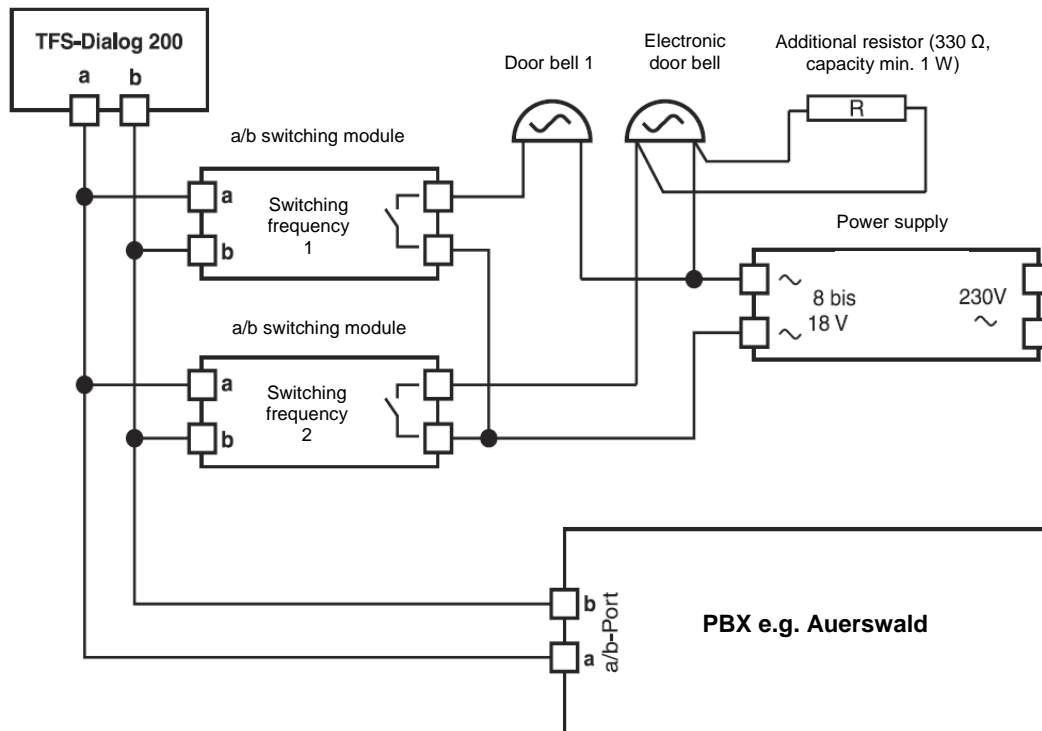

## Control of door openers and staircase lighting with a/b switching modules

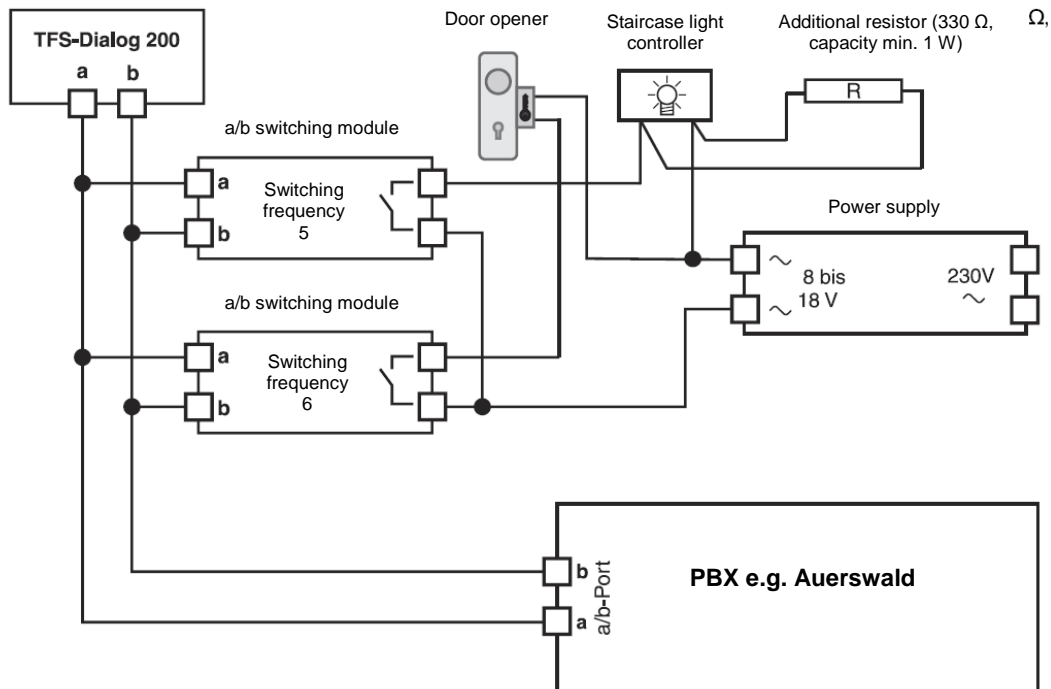

## Control of additional bells, door opener and staircase lighting

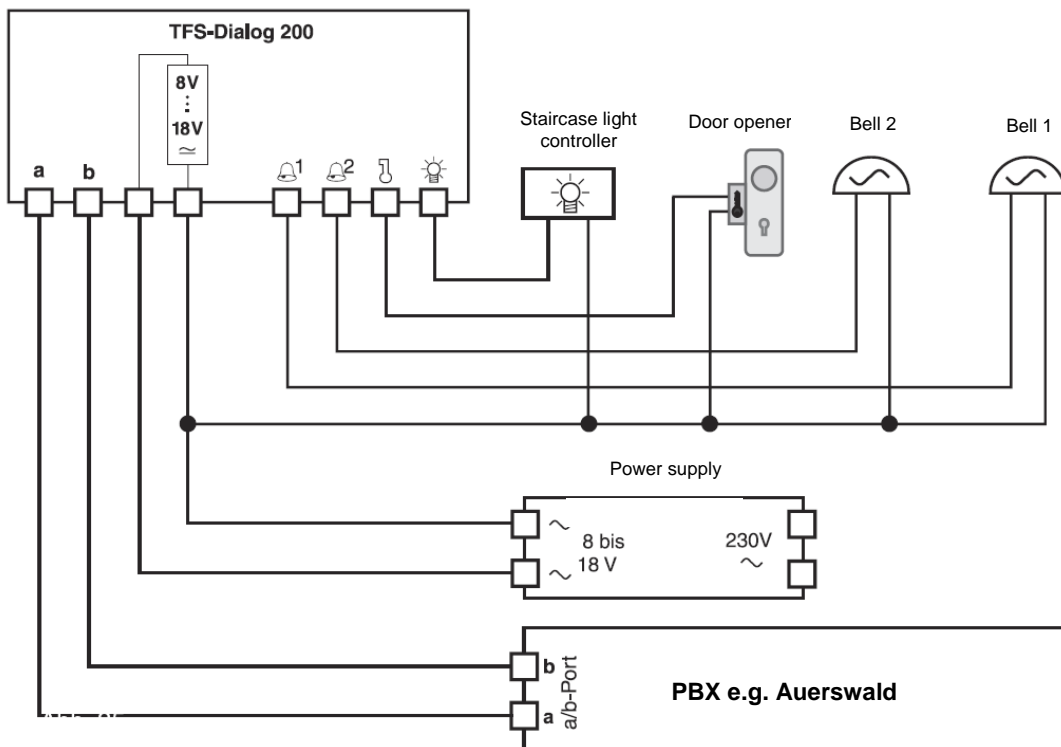

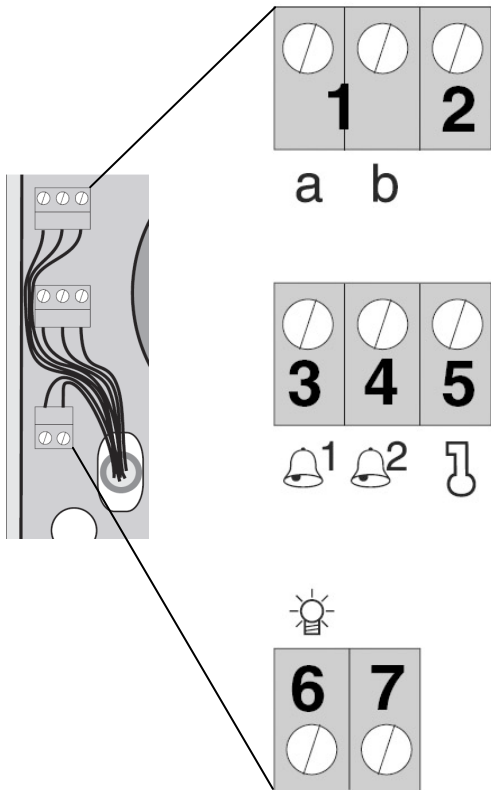

- 1 To the analog port of the PBX
- 2 Supply voltage out of the ringing transformer
- 3 Bell output 1
- 4 Bell output 2
- 5 Connection for the door opener
- 6 Connection for stairway lighting
- 7 Common connection for the Supply voltage out of the ringing transformer

Example: basic connection

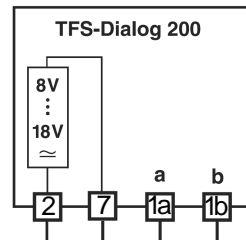

Connection to analog PBX port:  
Connection of the ringing transformer:

1a and 1b  
7 and 2

NOTES