

chapter four

Line-commutated converters

4.1 Introduction

The operating principle of a converter depends on the type of power switches and commutation methods employed. We consider two groups of power electronic switches.

- Incompletely controlled switches
- Self-commutated (full controlled) switches

The first group includes diodes, whose controllability is limited because they are switched under the action of forward voltage, and silicon-controlled rectifiers (thyristors). The second group contains all electronic switches that are turned on and off by currents or voltages arriving at their control input.

A fundamental difference between the two groups is the commutation method. In an electronic converter, commutation is understood to mean the transfer of current from one or more simultaneously conducting switches to other switches during a finite interval in which all the switches being turned on and off are in the conducting state. For the power electronic switches in the first group, commutation is possible by means of an ac voltage such as a grid voltage. For single-throw thyristors, such commutation is said to be natural if the conducting thyristors are turned off as a result of polarity reversal of an external supply voltage. Therefore, converters with power switches from the first group are sometimes known as line-commutated converters (International Electrical-Engineering Dictionary, 1998, IEC, BO050-551). They correspond to the operational principles of many converter circuits and hence will be the focus of attention in the present chapter (Rozanov, 1992; Rozanov et al., 2007). They are also sometimes classified on the basis of less significant characteristics such as the following:

- The rated power (low, moderate, high, etc.)
- The working voltage and current (low-voltage, high-voltage, low-current, high-current, etc.)
- The frequency of the input or output voltage (low-frequency, high-frequency, etc.)
- The number of phases (single-phase, three-phase, multiphase, etc.)

- The modular design principle (multicell, multilevel, etc.)
- The method of thyristor commutation (with capacitor commutation, commutation by an LC circuit, commutation under the action of load resonances, etc.)
- The presence of resonant circuits to reduce switching losses (quasi-resonant dc converters, etc.)
- The control method (in terms of the input or the output, modification of the switch control algorithm, etc.)

In practice, other aspects of converter operation are sometimes used for classification purposes. However, they usually lack clear definitions and are not mentioned in the corresponding standards.

4.2 Rectifiers

4.2.1 The rectification principle

In electronic power rectification, the ability of power electronic switches to conduct unidirectional current is employed to convert alternating current to direct current without significant energy losses. The specifics of the rectification process will depend on factors such as the following:

- The type of switch and its control method
- The dc load
- The characteristics of the ac source

In considering the rectification principle, we make the following assumptions:

1. A sinusoidal voltage source with stable frequency is connected to the dc side.
2. The switches employed are diodes VD or thyristors VS with ideal characteristics.
3. The load consists of specific point components.
4. There are no additional losses in the rectification circuit.

For a more detailed study of the factors affecting the rectification process, we consider the simplest possible circuit, with a single switch; this is known as a half-wave circuit (Figure 4.1a). The switch employed is a diode VD or thyristor VS. If the thyristor is turned on at moments when the firing angle $\alpha = 0$ (Figure 4.1a), the processes in the circuit will correspond to those observed when a diode is turned on. The following loads are considered.

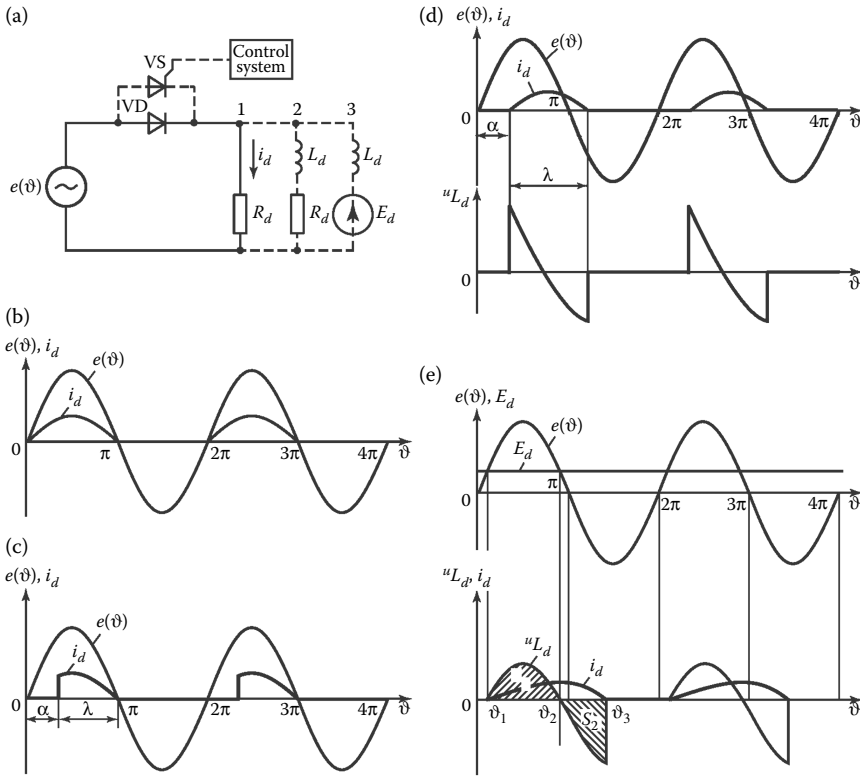

Figure 4.1 (a) A single-phase half-wave rectifier, voltage and current waveforms with an active load when (b) $\alpha = 0$ and (c) $\alpha = \pi/6$, with a resistive–inductive load when (d) $\alpha = \pi/6$, and (e) with a counter-emf load.

- An active load with resistance R_d (branch 1 in Figure 4.1a)
- An active–inductive load with resistance R_d and inductance L_d (branch 2 in Figure 4.1a)
- An opposing dc voltage source E_d with inductance L_d (counter-emf load; branch 3 in Figure 4.1a)

4.2.1.1 Circuit with active load

Here and in what follows, the time diagrams are plotted in terms of the angle $\vartheta = \omega t$, where ω is the angular frequency of the ac source. Thus, the input voltage is $e(\vartheta) = E_m \sin \vartheta$. In the circuit with diode VD , the current i_d begins to flow as soon as the forward voltage is applied. In other words, it conducts from the time $\vartheta = 0$ to $\vartheta = \pi$, when the voltage is zero and the diode is turned off. Negative voltage is applied to diode VD in the next half-period, and it is nonconducting. The current in load R_d reproduces

the input voltage during the conducting interval from 0 to π . At time $\vartheta = 2\pi$, the cycle repeats (Figure 4.1b).

When diode VD is replaced by thyristor VS, current flow begins when the control pulse is supplied to the thyristor gate from the control system (CS). The delay after time $\vartheta = 0$ will depend on the firing angle α (Figure 4.1c). The thyristor will be switched off when voltage $e(\vartheta)$ (and hence current i_d) falls to zero, that is, when $\vartheta = \pi$. As a result, current i_d will flow for a shorter time than with a diode, specifically, for time $\lambda = \pi - \alpha$.

In this interval, the current reproduces the form of the voltage $e(\vartheta)$. As a result, periodic unidirectional currents i_d appear at load R_d , which indicates rectification. In other words, a constant component of current I_d will appear in the load R_d when voltage $e(\vartheta)$ is supplied by an ac source.

4.2.1.2 Circuit with resistive–inductive load

The character of the load on the dc side has considerable influence on the rectification process. For example, if a thyristor is turned on at time $\vartheta = \alpha$ in a load containing not only resistor R_d , but also a reactor with inductance L_d (branch 2 in Figure 4.1a), the current i_d will be determined by the equation

$$E_m \sin \vartheta = i_d R_d + L_d \frac{di_d}{dt}, \quad (4.1)$$

which is derived from the equivalent circuit in the presence of thyristor VS. With zero current in the inductance L_d when the thyristor is turned on, the solution of Equation 4.1 takes the form

$$i_d(\vartheta) = \frac{E_m}{\sqrt{R_d^2 + (\omega L_d)^2}} \left(\sin(\vartheta - \varphi) - \sin(\alpha - \varphi) \cdot e^{(-\vartheta + \alpha)/\tau\omega} \right), \quad (4.2)$$

where

$$\varphi = \arctg \frac{\omega L_d}{R_d} \quad \text{and} \quad \tau = \frac{L_d}{R_d}.$$

Figure 4.1d shows the input voltage $e(\vartheta)$ and current i_d when $\alpha = \pi/3$. It is evident that the current i_d continues to flow through the thyristor after voltage $e(\vartheta)$ passes through zero. This is possible because the energy stored in the inductance L_d during the first half-period maintains the current i_d after the voltage reverses the sign until the time $\vartheta = \alpha + \lambda - \pi$, when current i_d is again zero.

4.2.1.3 Counter-emf load

A load in the form of a dc emf with polarity opposite to the switch may also be of practical interests. Such rectification circuits are used, for instance, in battery chargers and in systems for power recuperation from a dc source to an ac grid.

In some operating conditions, a large filter capacitor at the rectifier output may be regarded as a counter-emf source.

Branch 3 in Figure 4.1a corresponds to a half-wave rectifier circuit with diode VD and counter-emf E_d . At time $\vartheta = \vartheta_1$ (Figure 4.1e), the source voltage $e(\vartheta)$ exceeds the counter-emf E_d . Hence, forward voltage is applied to diode VD and it begins to conduct current i_d in the opposite direction to E_d . Under the assumptions already noted, connecting a source with voltage $e(\vartheta)$ to the counter-emf E_d will result in infinite growth in current i_d . To prevent this, a reactor with inductance L_d is introduced in the dc circuit. In that case, the current i_d will be

$$i_d(\vartheta) = \frac{1}{\omega L_d} \int_{\vartheta_1}^{\vartheta} (e(\vartheta) - E_d) d\vartheta. \quad (4.3)$$

The period corresponding to flow of current i_d may be divided into two parts an increase in i_d in the interval ϑ_1 – ϑ_2 and a decrease in i_d in the interval ϑ_2 – ϑ_3 . At time ϑ_2 , $e(\vartheta)$ is again equal to the counter-emf E_d . The second interval corresponds to voltage regions of opposite polarity at inductance L_d . The integral areas S_1 and S_2 of these regions (shaded in Figure 4.1e) are equal. That corresponds to balance of the stored and consumed energy in inductance L_d

$$\int_{\vartheta_1}^{\vartheta_2} u_L(\vartheta) d\vartheta + \int_{\vartheta_2}^{\vartheta_3} u_L(\vartheta) d\vartheta = 0. \quad (4.4)$$

When $\vartheta = \vartheta_2$, the current i_d is maximum. At specified values of $e(\vartheta)$ and E_d , the replacement of diode VD by a controllable thyristor permits the regulation of i_d by adjusting the firing angle α . This angle corresponds to the switching delay of the thyristor relative to the time ϑ_1 at which a forward voltage is applied to the thyristor.

4.2.2 Basic rectification circuits

We will consider idealized rectification circuits, under the following assumptions:

1. The semiconductor components are ideal. In other words, when they are on, their resistance is zero; when they are off, their conductivity is zero.
2. The semiconductor components are switched on and off instantaneously. In other words, the switching process takes no time.
3. The resistance of the circuits connecting the components is zero.
4. The resistance of the transformer windings (active and inductive), the energy losses in its magnetic system, and the magnetizing current are all zero.

The electromagnetic processes associated with rectification are considered for two types of static load: active and active-inductive. Such loads are typical of most moderate- and high-power rectifiers.

In this section, we consider thyristors operating with active and active-inductive loads when the firing angle $\alpha > 0$. Obviously, when $\alpha = 0$, the processes in the circuit will be the same as for uncontrollable diode-based rectifiers. As the three-phase bridge circuit is most common, we will consider processes with $\alpha = 0$ in that case.

4.2.2.1 Single-phase circuit with center-tapped transformer

A single-phase full-wave circuit with a center tap is shown in Figure 4.2a. The full-wave circuit is sometimes known as a two-cycle or two-phase circuit, as it rectifies both voltage half-waves. In this circuit, the secondary half-windings of the transformer relative to the tap create a system of voltages with a mutual phase shift $\vartheta = \pi$.

We will consider the operation of the circuit with an active load (when switch S in Figure 4.2a is closed). Suppose that, beginning at $\vartheta = 0$, both thyristors are off, and no current flows. We assume that the potential of point a of the secondary winding is positive relative to the tap (point 0), whereas point b is negative. (In Figure 4.2a, this polarity is noted outside the parentheses.) Obviously, with this polarity of the secondary-winding voltage, the forward voltage $u_{VS1} = u_{a0}$ will be applied to thyristor $VS1$, whereas inverse voltage u_{b0} will be applied to thyristor $VS2$. Suppose that at time $\vartheta = \alpha$ (i.e., with delay α relative to the moment when voltage u_{a0} passes through zero), a control pulse is supplied to the control electrode of thyristor $VS1$. Then $VS1$ is switched on, and current $i_d = i_{VS1}$ begins to flow in load R_d under the action of voltage u_{a0} . Beginning at that moment, inverse voltage u_{ab} will be applied to thyristor $VS2$. Here u_{ab} is the difference between the voltages in the secondary half-windings u_{a0} and u_{b0} .

Thyristor $VS1$ will be on until the current flow falls to zero. As the load is active and the current passing through the load—and hence through thyristor $VS1$ —is of the same form as voltage u_{a0} , thyristor $VS1$ is switched off at time $\vartheta = \pi$. As the voltage at the secondary winding

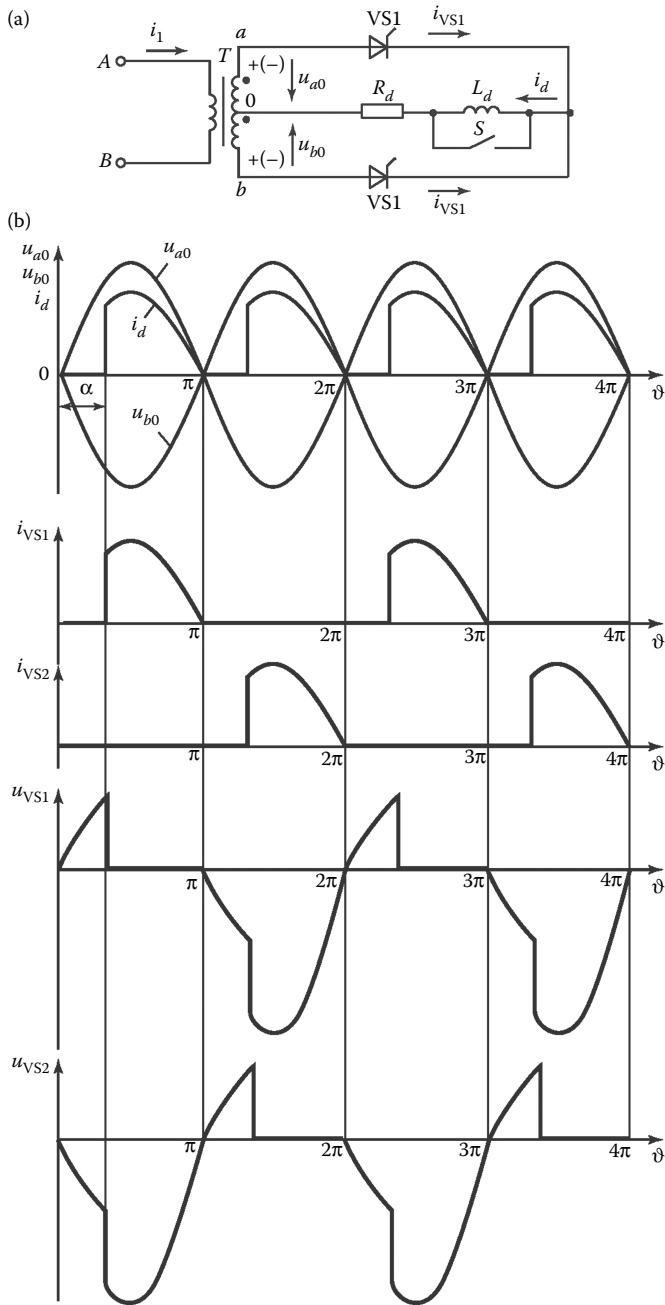

Figure 4.2 (a) A single-phase full-wave rectifier with center-tapped transformer and (b) corresponding voltage and current waveforms.

reverses polarity after half of the period, the supply of a control pulse at time $\vartheta = \pi + \alpha$ switches thyristor VS2 on. These processes are repeated in each period.

The possibility of a specific phase delay α in the moments at which the thyristors are switched on permits change in the output voltage. We measure α from the moments of natural thyristor switching ($\vartheta = 0, \pi, 2\pi, \dots$), corresponding to the moments when diodes are turned on in an uncontrollable circuit. It is evident from Figure 4.2b that, with an increase in α , the average output voltage U_d will decline. Analytically, this dependence takes the form

$$U_d = \frac{1}{\pi} \int_{\alpha}^{\pi} \sqrt{2} U_2 \sin \vartheta d\vartheta = \frac{\sqrt{2}}{\pi} U_2 (1 + \cos \alpha), \quad (4.5)$$

where U_2 is the real voltage at the transformer's secondary winding.

If we denote the average rectified voltage for an uncontrolled rectifier ($\alpha = 0$) by U_{d0} , determined from Equation 4.5, we may write

$$U_d = U_{d0} \frac{1 + \cos \alpha}{2}. \quad (4.6)$$

According to Equation 4.6, an increase in α from 0 to π reduces the average output voltage from U_d to zero. The dependence of the average output voltage on the firing angle is known as the control characteristic.

The presence of inductance L_d in the dc circuit at $\alpha > 0$ means that current will flow through the thyristor after the voltage at the secondary half-winding passes through zero, on account of the energy stored in the inductance. For example, thyristor VS1 continues to conduct current after the voltage u_{a0} becomes negative (Figure 4.3a). As a result, the period λ of current flow through the thyristor increases, and the rectified voltage will include a section of negative polarity from 0 to ϑ_1 , when the current in the thyristors falls to zero. With an increase in L_d , the thyristors will conduct for a time $\lambda = \pi$, and $\vartheta_1 = \alpha$. This corresponds to a boundary-continuous rectified current i_d . In these conditions, each thyristor conducts current for half-period π , with zero current at the beginning and end of each half-period. The inductance L_d at which such behavior is observed is said to be the boundary or critical inductance. With a further increase in L_d or with an increase in the rectifier load, the rectified current remains continuous and its pulsations are smoothed. At large values $\omega L_d / R_d > 5-10$, the current i_d is practically completely smoothed, and rectangular current flows through the thyristors (Figure 4.3b). Obviously, with an increase in α , the area of the negative sections in the rectified voltage increases, and hence the average rectified voltage declines. The average rectified voltage corresponds to its

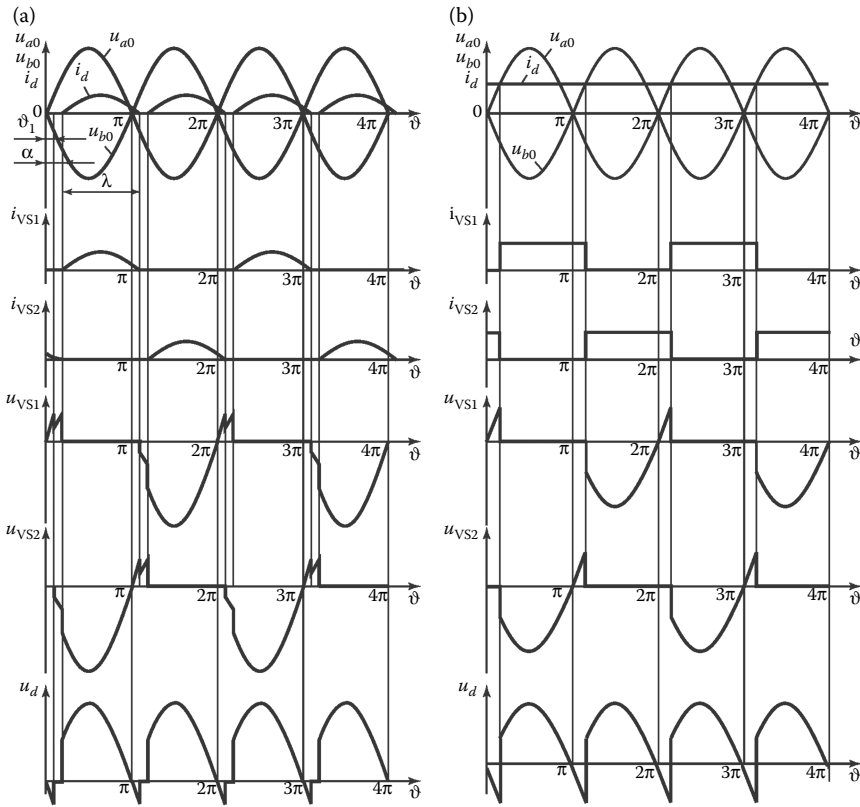

Figure 4.3 Voltage and current waveforms for a single-phase center-tapped full-wave rectifier in the case of a resistive–inductive load ($\alpha = \pi/6$): (a) discontinuous load current and (b) smoothed continuous load current ($\omega L_d = \infty$).

constant component. When $\omega L_d = \infty$, the constant component is applied at resistance R_d and the variable component at inductance L_d .

As the form of the rectified voltage is repeated in the interval from α to $\pi + \alpha$, its average value may be found from the formula

$$U_d = \frac{1}{\pi} \int_{\alpha}^{\pi+\alpha} \sqrt{2} \cdot U_2 \sin \vartheta d\vartheta = \frac{\sqrt{2}}{\pi} U_2 \cos \alpha = U_{d0} \cos \alpha. \quad (4.7)$$

According to Equation 4.7, the average rectified voltage is zero when $\alpha = \pi/2$. In that case, the areas of the positive and negative sections in the rectified voltage are equal, and there is no constant component (Figure 4.4). The control characteristic for a resistive–inductive load corresponds to curve 2 in Figure 4.5.

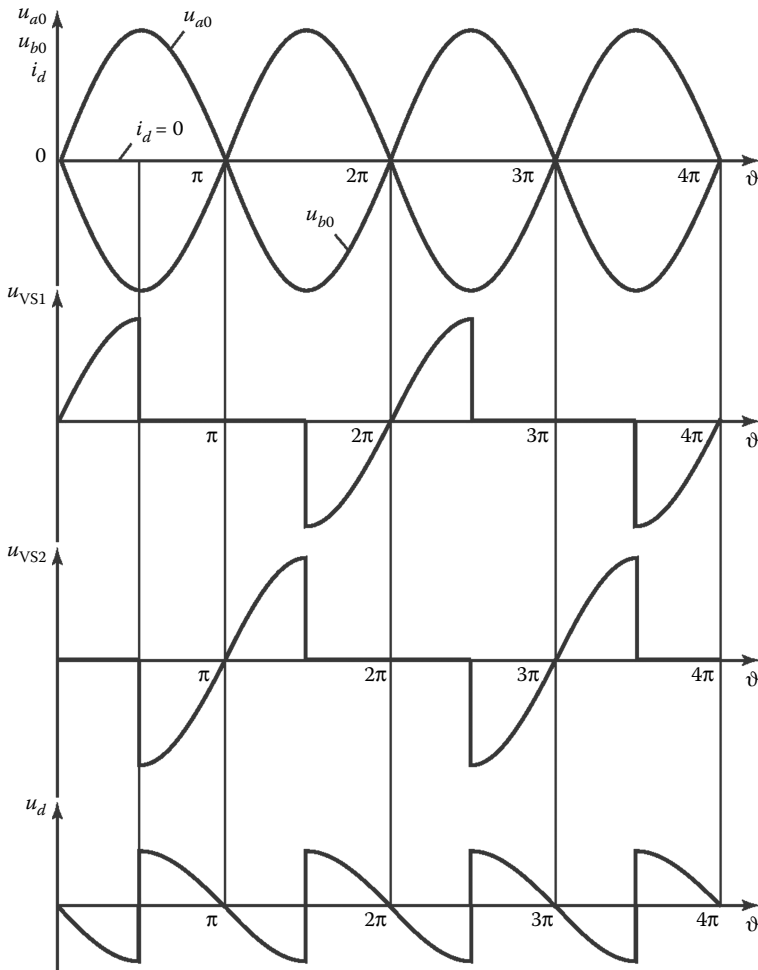

Figure 4.4 Voltage waveforms for a single-phase center-tapped full-wave circuit in the case of a resistive-inductive load and $\alpha = \pi/2$.

If the value of $\omega L_d/R_d$ is such that the energy stored in inductance L_d in the interval when $u_d > 0$ is insufficient for current flow over half of the period, the thyristor that is conducting this current will be switched off before the control pulse is supplied to the other thyristor. In other words, current i_d will be discontinuous. If we compare Figure 4.3a and b, we see that, at the same α , the average rectified voltage will be greater for discontinuous current than for continuous current, due to the decrease in the area of the negative section on the rectified-voltage curve, but less than for rectifier operation with an active load (with

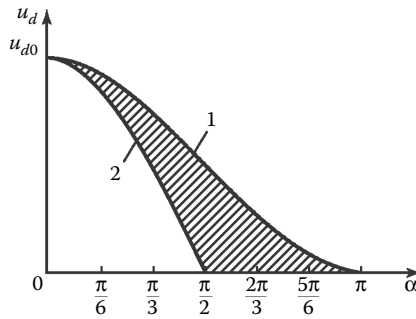

Figure 4.5 Control characteristics of a single-phase full-wave rectifier in the case of an active load (1) and RL load (2).

no negative sections). Therefore, with discontinuous current, the control characteristics will be between curves 1 and 2, within the shaded region in Figure 4.5.

With discontinuous current, the transformer and thyristor circuits operate in more challenging conditions, as the effective value of the currents in the circuit elements is greater at the same average rectified current. Therefore, in powerful rectifiers operating with a wide variation of α , the inductance L_d is usually selected so as to ensure the continuous rectified current at near-rated loads.

The parameters of the circuit components are calculated by classical electrical-engineering methods. For example, the average thyristor current is

$$I_{avVS1} = I_{avVS2} = \frac{1}{\pi} \int_0^{\pi} i_{VS}(\vartheta) d\vartheta. \tag{4.8}$$

When $\omega L_d = \infty$, the ideally smoothed constant load current I_d is conducted alternately by the thyristors. Hence

$$I_{avVS1} = I_{avVS2} = \frac{1}{2} I_d. \tag{4.9}$$

If the current i_d is ideally smooth, it is simple to determine the effective and maximum currents and voltages at all the circuit components. Their determination is more complex in the case of poorly smoothed or discontinuous current i_d . In that case, equivalent circuits must be formulated for the thyristor conduction periods.

4.2.2.2 Single-phase bridge circuit

For a single-phase bridge circuit (Figure 4.6) operating with $\alpha > 0$, the voltages and currents at its components are of the same form as in a single-phase center-tap full-wave circuit (Figures 4.2 through 4.5). The basic difference is that a single-phase voltage U_{ab} is supplied, rather than the half-winding voltages U_{a0} and U_{b0} . As a result, two thyristors VS1 and VS3 or VS2 and VS4 participate in the rectification of each voltage half-wave. Therefore, when the firing angle $\alpha = 0$ (or in an uncontrollable diode-based rectifier), the average rectified voltage at the load is

$$U_{d0} = \frac{2\sqrt{2}}{\pi} U_2, \quad (4.10)$$

where U_2 is the effective voltage in the transformer's secondary winding.

Depending on whether the load is active or active-inductive, the average rectified voltage U_d may be calculated as follows.

a. With an active load

$$U_d = U_{d0} \frac{1 + \cos \alpha}{2}, \quad (4.11)$$

where U_{d0} is the average rectified voltage at the output when $\alpha = 0$.

b. With an active-inductive load (when ωL_d is such that the rectified current is continuous)

$$U_d = U_{d0} \cos \alpha. \quad (4.12)$$

The control characteristics of the circuit depend on the ratio $\omega L_d/R_d$ and take the form as in Figure 4.5.

In this case, as in the center-tapped circuit, the power of the components increases with an increase in α in the case of an active load and an active-inductive load with discontinuous currents. This must be taken into account in the calculation and design of the corresponding power components.

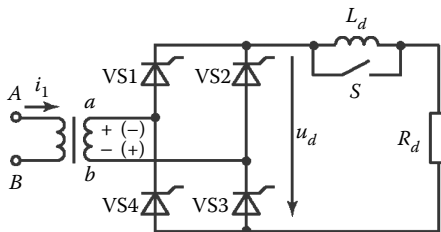

Figure 4.6 A single-phase bridge rectifier.

4.2.2.3 Three-phase circuit with center-tapped transformer

1. *Operation with $\alpha = 0$.* The three-phase circuit with a tap (Figure 4.7) is a three-phase single-cycle circuit, as only one half-wave of the alternating voltage in each phase is rectified. We will consider the operating principle of this circuit for the case in which the primary transformer windings are in a delta configuration, whereas the secondary windings are in a star configuration. First, we assume that switch S is closed. In other words, the circuit has an active load. The relations are then refined for the case in which switch S is open, on the assumption that $\omega L_d = \infty$.

In the interval $\vartheta_0 < \vartheta < \vartheta_1$ (Figure 4.8), thyristor VS1, connected to phase a , is conducting. Beginning at time ϑ_1 , the potential of phase b exceeds that of phase a , and the anode of thyristor VS2 is at a positive voltage relative to the cathode. If a control pulse is supplied to thyristor VS2 at time ϑ_1 , it is switched on, whereas thyristor VS1 is switched off under the action of the shutoff voltage u_{ab} . The load current i_d begins to flow through thyristor VS2, which is connected to phase b .

The conducting state of thyristor VS2 continues for a period of 120° , until time ϑ_2 , when the potential of phase c exceeds that of phase b and a control pulse is supplied to thyristor VS3. At time ϑ_2 , thyristor VS3 begins to conduct, and thyristor VS2 is switched off. Then, at time ϑ_3 , current flow resumes at thyristor VS1, and the preceding sequence is cyclically repeated.

Obviously, each thyristor will conduct for a third of the grid voltage period ($2\pi/3$). For the remainder of the period ($4\pi/3$), the thyristor is off and is subject to reverse voltage. Thus, when thyristor VS1 is off, the line voltage u_{ba} is applied to VS1 during the period when thyristor VS2 is conducting, whereas voltage u_{ca} is applied when thyristor VS3 is conducting. As a result, reverse voltage u_{VS1} is applied to thyristor VS1 (Figure 4.8).

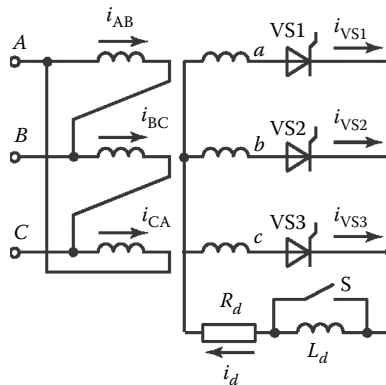

Figure 4.7 A three-phase center-tapped rectifier.

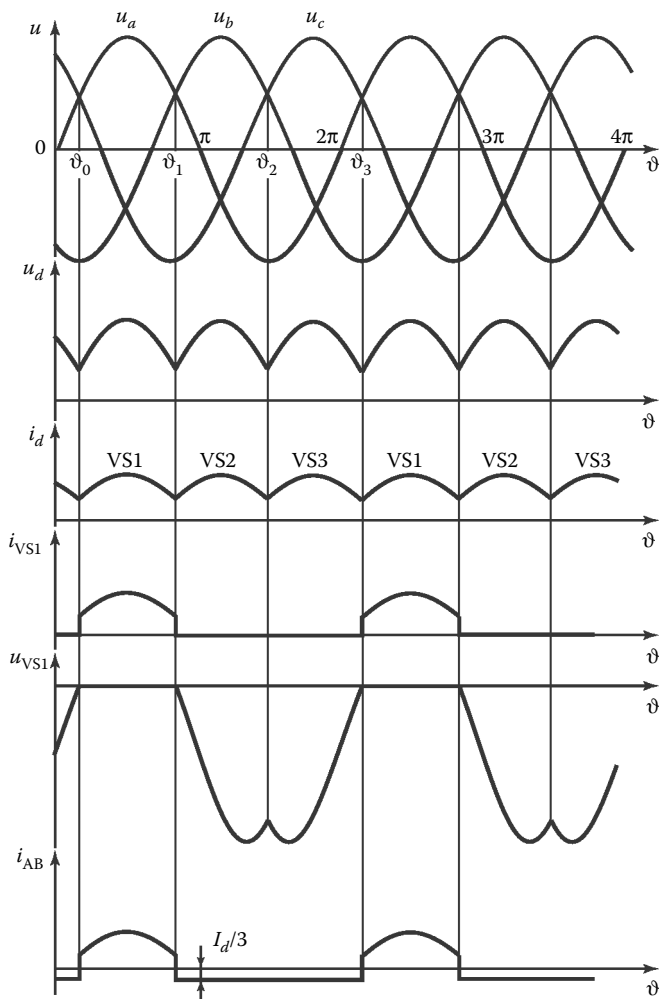

Figure 4.8 Voltage and current waveforms for a center-tapped three-phase rectifier when $\alpha = 0$.

The average rectified voltage is found by integrating the voltage at the transformer's secondary winding over the interval corresponding to repetition of the rectified voltage form

$$U_d = \frac{3}{2\pi} \int_{\pi/6}^{5\pi/6} \sqrt{2}U_2 \sin \vartheta \, d\vartheta = \frac{3\sqrt{6}}{2\pi} U_2 = 1.17 U_2, \quad (4.13)$$

where U_2 is the effective phase voltage at the transformer's secondary winding.

The basic parameters characterizing thyristor operation in the circuit are as follows.

- The circuit coefficient is

$$k = 3 \frac{\sqrt{6}}{2\pi}. \quad (4.14)$$

- The maximum reverse voltage at the thyristor (equal to the line voltage at the secondary windings) is

$$U_{R\max} = \sqrt{3} U_{2m} = \sqrt{6} U_2 = \frac{\pi}{3} U_d, \quad (4.15)$$

where U_{2m} is the amplitude of the phase voltage.

- The maximum thyristor current is

$$I_{\max} = \frac{U_{2m}}{R_d} = \frac{\pi}{3\sqrt{3}} U_d. \quad (4.16)$$

- The average current through the thyristor, given that each thyristor conducts for a third of the period, is

$$I_{\text{avVS}} = \frac{I_d}{3}. \quad (4.17)$$

As the secondary-winding currents in this circuit are pulsating and include a constant component, an induced magnetization flux appears in the transformer magnetic system and can result in magnetic saturation. That entails increase in the calculated transformer power. The currents in the primary windings only contain variable components, as the constant components are not transformed. Therefore, the currents in the primary windings take the form

$$\left. \begin{aligned} i_{AB} &= \left(i_{VS1} - \frac{1}{3} I_d \right), \\ i_{BC} &= \left(i_{VS2} - \frac{1}{3} I_d \right), \\ i_{CA} &= \left(i_{VS3} - \frac{1}{3} I_d \right). \end{aligned} \right\} \quad (4.18)$$

We consider the currents in the thyristors and the transformer windings and the calculated transformer power for a circuit with an active–inductive load, which is most typical of three-phase and multiphase rectification systems. In the case of an active–inductive load, the circuit operation is the same as with an active load, but the current i_d is ideally smoothed, whereas the currents through the thyristors are rectangular. Correspondingly, the currents in the transformer windings are also rectangular. In that case, the curves of the rectified voltage u_d and the reverse voltages at the thyristors are the same as in the case of an active load, and the currents are as follows

$$\left. \begin{aligned} I_{\max} &= \frac{I_d}{3}, \\ I_2 &= I_{VS} = \frac{I_d}{\sqrt{3}}, \\ I_1 &= \frac{1}{k_T} \frac{\sqrt{2}}{3} I_d. \end{aligned} \right\} \quad (4.19)$$

The calculated power of the transformer's primary and secondary windings may be written in the form

$$\left. \begin{aligned} S_1 &= 3U_1I_1 = \frac{2\pi}{3\sqrt{3}} P_d, \\ S_2 &= 3U_2I_2 = \frac{2\pi}{3\sqrt{2}} P_d, \end{aligned} \right\} \quad (4.20)$$

where U_1 and U_2 are the effective phase voltages of the primary and secondary windings, I_1 and I_2 are the effective currents in the primary and secondary windings, respectively, and P_d is the average load power.

2. *Operation with $\alpha > 0$.* In this case, in contrast to an uncontrollable rectifier or a controllable rectifier with $\alpha = 0$, the control pulses reach the thyristors alternately, with a delay α relative to the time at which the sinusoid of the line voltage in the secondary transformer windings passes through zero. The times at which the sinusoidal line voltage passes through zero correspond to intersection of the sinusoidal phase voltages u_a , u_b , and u_c . When the firing angle $\alpha > 0$, different operating conditions may be observed, depending on the type of load and the range of α .

If α varies in the range from 0 to $\pi/6$ (Figure 4.9), the rectified current is continuous for both active and active–inductive loads. The average rectified voltage in this range of α is described as follows:

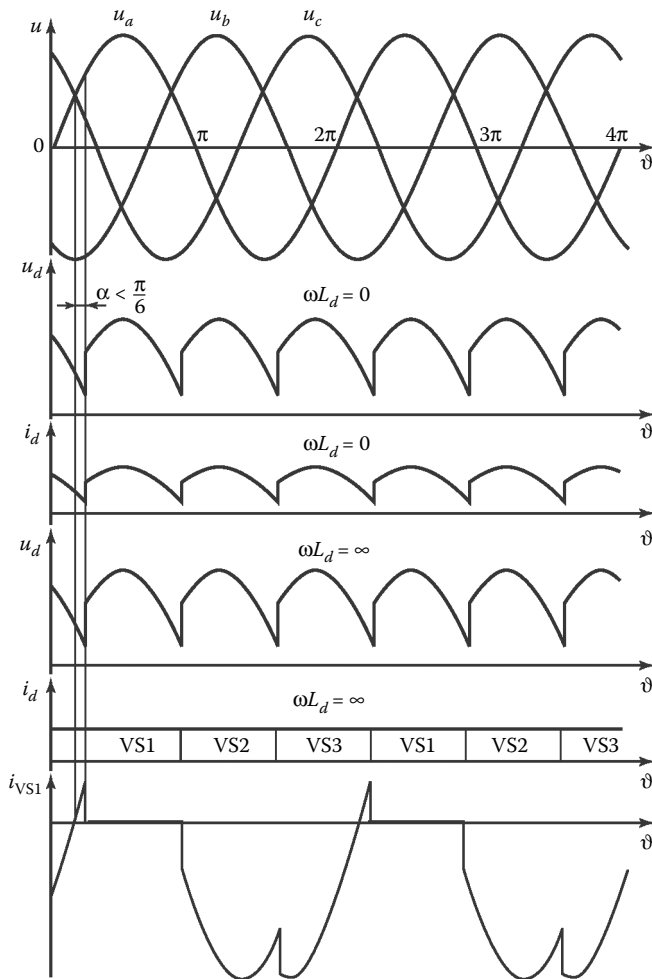

Figure 4.9 Voltage and current waveforms for a center-tapped three-phase rectifier when $\alpha < \pi/6$.

$$U_d = \frac{3}{2\pi} \int_{(\pi/6)+\alpha}^{(5\pi/6)+\alpha} \sqrt{2} U_2 \sin \vartheta \, d\vartheta = \frac{3\sqrt{6}}{2\pi} U_2 \cos \alpha = U_{d0} \cos \alpha. \quad (4.21)$$

When $\alpha = \pi/6$, the instantaneous rectified voltage is zero at the thyristor switching times (Figure 4.10, left). This is said to be a boundary-continuous operation. When $\alpha > \pi/6$, the rectified current i_d becomes discontinuous in the case of active load, and there are sections where the

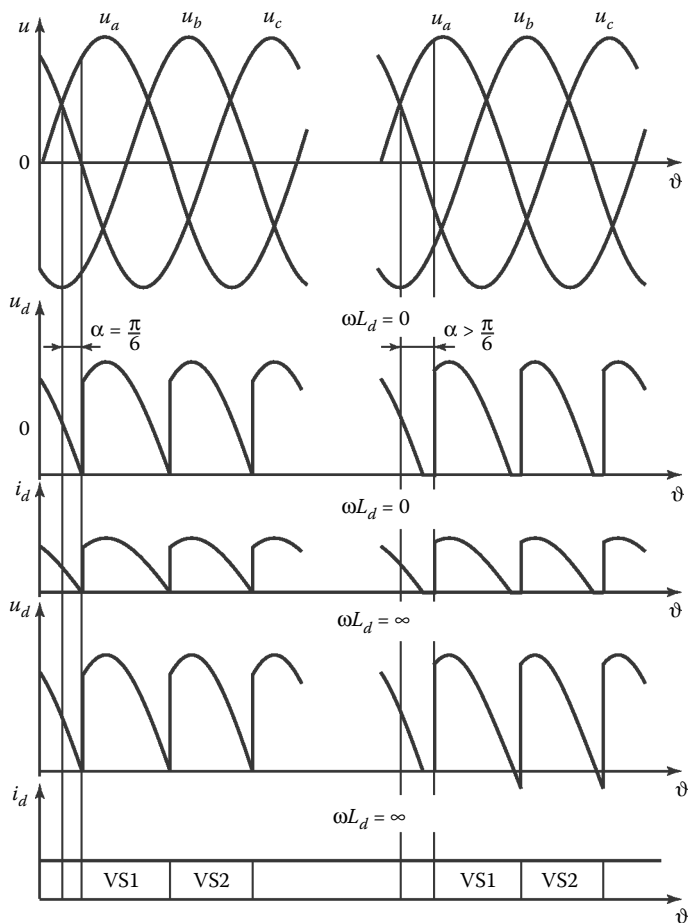

Figure 4.10 Voltage and current waveforms for a center-tapped three-phase rectifier when $\alpha = \pi/6$ and $\alpha > \pi/6$.

rectified voltage u_d is zero (Figure 4.10, right). The interval in which the thyristors are conducting becomes less than $2\pi/3$. In this case, the average voltage is

$$\begin{aligned}
 U_d &= \frac{3}{\pi} \int_{(\pi/6)+\alpha}^{\pi} \sqrt{2} U_2 \sin \vartheta \, d\vartheta = \frac{3\sqrt{2}}{2\pi} U_2 \left[1 + \cos\left(\frac{\pi}{6} + \alpha\right) \right] \\
 &= U_{d0} \left[\frac{1 + \cos\left(\frac{\pi}{6} + \alpha\right)}{\sqrt{3}} \right].
 \end{aligned} \tag{4.22}$$

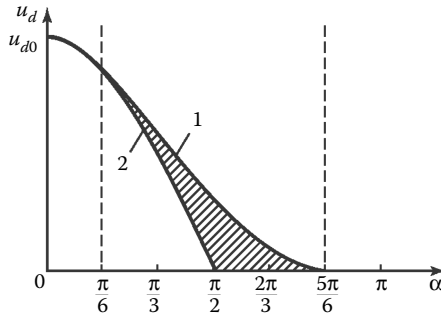

Figure 4.11 Control characteristics for a center-tapped three-phase rectifier with an active load (1) and an RL load (2).

With an active-inductive load, the energy stored in the inductance L_d sustains the rectified current i_d in the load even after the rectified voltage becomes negative. If the energy stored in the inductance L_d lasts until the thyristors are switched again, operation with continuous current i_d is possible. When $\omega L_d = \infty$, continuous current will be observed for any α in the range from 0 to $\pi/2$. In that case, the average output voltage U_d may be determined from Equation 4.21. When $\alpha = \pi/2$, the positive and negative sections within the rectified voltage curve are equal in area. That indicates the lack of a constant component in the rectified voltage; in other words, the average value of U_d is zero.

In accordance with the foregoing, we can distinguish two characteristic intervals of α in the control characteristics (Figure 4.11). In the first ($0 < \alpha < \pi/6$), with either active load or active-inductive load, the control characteristics correspond to Equation 4.21. In the second ($\pi/6 < \alpha < 5\pi/6$), with an active load, the control characteristic is analytically described by Equation 4.22, and the average value of U_d is zero when $\alpha = 5\pi/6$. In the case of an active-inductive load, with continuous current i_d , the control characteristic in the range $\pi/6 < \alpha < 5\pi/6$ corresponds to Equation 4.21. The shaded region indicates the family of control characteristics in the case of discontinuous current i_d with different values of $\omega L_d/R_d$.

4.2.2.4 Three-phase bridge circuit

1. *Operation with $\alpha = 0$.* The three-phase bridge circuit is shown in Figure 4.12. The corresponding current and voltage waveforms are shown in Figure 4.13 for the case in which $\alpha = 0$. We now consider circuit operation for an active load (with switch S closed). Beginning at time ϑ_1 , current flows through thyristors $VS1$ and $VS6$, whereas the other thyristors are off. In that case, the line voltage u_{ab} is applied to load R_d , and current i_d flows through the circuit consisting of phase winding a, thyristor $VS1$, load R_d ,

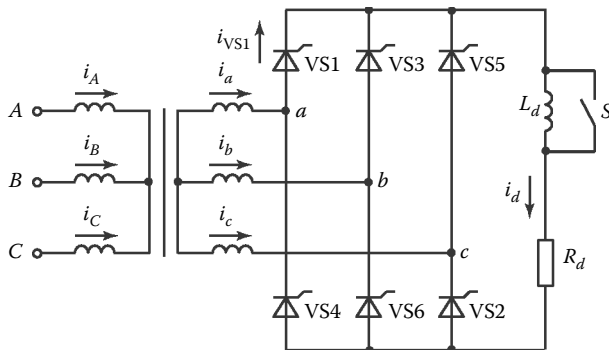

Figure 4.12 A three-phase bridge rectifier.

thyristor VS6, and phase winding b. This process continues until time ϑ_2 (for a period of $\pi/3$), when the potential of phase b becomes more positive than that of phase c. At time ϑ_2 , voltage u_{bc} becomes positive; in other words, it is a forward voltage for thyristor VS2. If a control pulse is supplied at that moment to thyristor VS2, it begins to conduct, while thyristor VS6 is switched off. (There is commutation of thyristors VS6 and VS2.) For thyristor VS6, u_{bc} is a reverse voltage. As a result, thyristors VS1 and VS2 are on, while the others are off.

At time ϑ_3 , a pulse is supplied to thyristor VS3, which is switched on. Thyristor VS1 is off, as the potential of phase b is greater than that of phase a. Then, at intervals of $\pi/3$, commutation of the following thyristor pairs is observed: VS2–VS4, VS3–VS5, VS4–VS6, and VS5–VS1. Thus, within the period of the supply voltage, there will be six commutations at intervals of $\pi/3$. Three occur in the cathode group of thyristors VS1, VS3, and VS5 (with connected cathodes), and three in the anode group of thyristors VS4, VS6, and VS2 (with connected anodes). Note that the number of thyristors in this circuit is not random but corresponds to the order in which they operate for the specified transformer phase sequence in Figure 4.12.

The sequential operation of different thyristor pairs in the circuit leads to the appearance of a rectified voltage at resistance R_d ; it consists of parts of the line voltages of the secondary transformer windings (Figure 4.13). It is evident that, at commutation, the line voltages pass through zero (when two phase voltages— u_a and u_b , say—are equal). Current flows through each thyristor for a time $2\pi/3$; for the remainder of the period, reverse voltage consisting of segments of the corresponding line voltages is applied to the thyristors.

The constant component of the rectified voltage (the average value) is calculated over the interval of repetition of the rectified voltage ($\pi/3$)

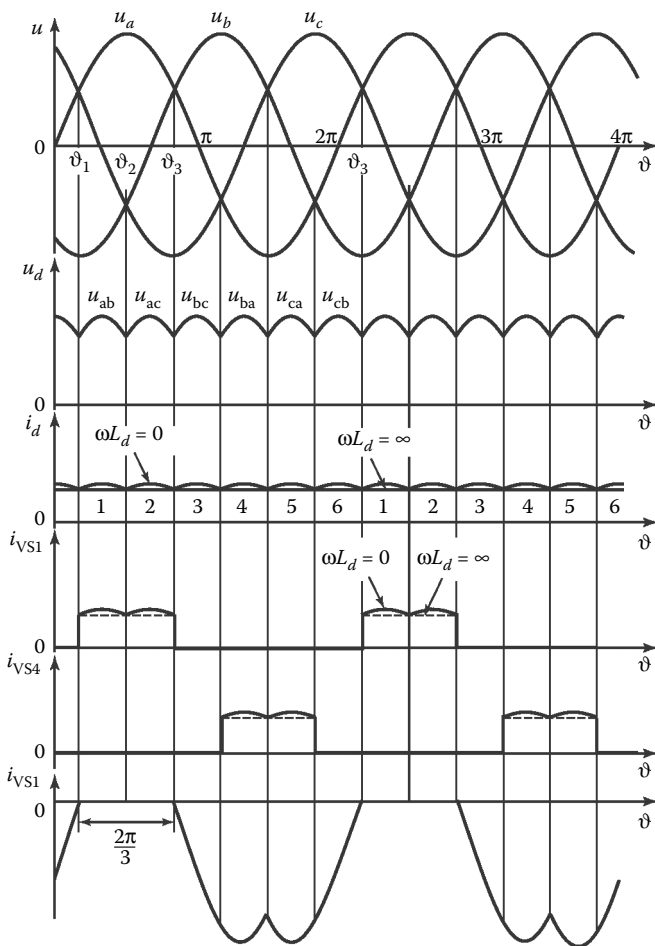

Figure 4.13 Voltage and current waveforms for a three-phase bridge rectifier ($\alpha = 0$).

$$U_d = \frac{3}{\pi} \int_{\pi/3}^{2\pi/3} \sqrt{6} \cdot U_2 \sin \vartheta d\vartheta = \frac{3\sqrt{6}}{\pi} U_2, \quad (4.23)$$

where U_2 is the effective value of the phase voltage at the secondary transformer windings.

Equation 4.23 applies to both active and active-inductive loads. When $\omega L_d = \infty$, the operation of the thyristors in the circuit is characterized by the following parameters.

- The maximum reverse voltage at the thyristor (equal to the amplitude of the line voltage at the secondary winding) is

$$U_{R\max} = \sqrt{2} \cdot U_{2\text{line}}. \quad (4.24)$$

- The maximum thyristor current is

$$I_{\max} = I_d. \quad (4.25)$$

- The average thyristor current is

$$I_{\text{avVS}} = \frac{I_d}{3}. \quad (4.26)$$

2. *Operation with $\alpha > 0$.* In a three-phase bridge circuit based on thyristors, the control pulses are sent with delay α relative to the zeros of the line voltages (the moments when sinusoidal phase voltages intersect; Figure 4.14).

Due to the delay α , the average rectified voltage formed from the corresponding segments of the line voltages is reduced. As long as the instantaneous rectified voltage u_d remains above zero (in the range $0 < \alpha < \pi/3$), the rectified current I_d will be continuous, regardless of the load. Therefore, in that range of α , the average rectified voltage for active and active-inductive loads is

$$U_d = \frac{3}{\pi} \int_{-(\pi/3)+\alpha}^{(2\pi/3)+\alpha} \sqrt{3} \cdot U_2 \sin \vartheta d\vartheta = \frac{3\sqrt{6}}{\pi} U_2 \cos \alpha = U_{d0} \cos \alpha. \quad (4.27)$$

With an active load, the firing angle $\alpha = \pi/3$ corresponds to boundary-continuous operation (Figure 4.15, left). When $\alpha > \pi/3$, with an active load, intervals of zero voltage u_d and zero current i_d appear. In other words, operation with discontinuous rectified current begins. In that case, the average rectified voltage is reduced.

When $\alpha = \pi/2$, the positive and negative sections within the rectified voltage curve are equal in area. That indicates the lack of a constant component in the rectified voltage; in other words, the average value of U_d is zero (Figure 4.15, right).

Note that, with discontinuous current i_d , double control pulses separated by some interval or single pulses of length greater than $\pi/3$ must be supplied to the thyristors not only to ensure operation of the circuit, but

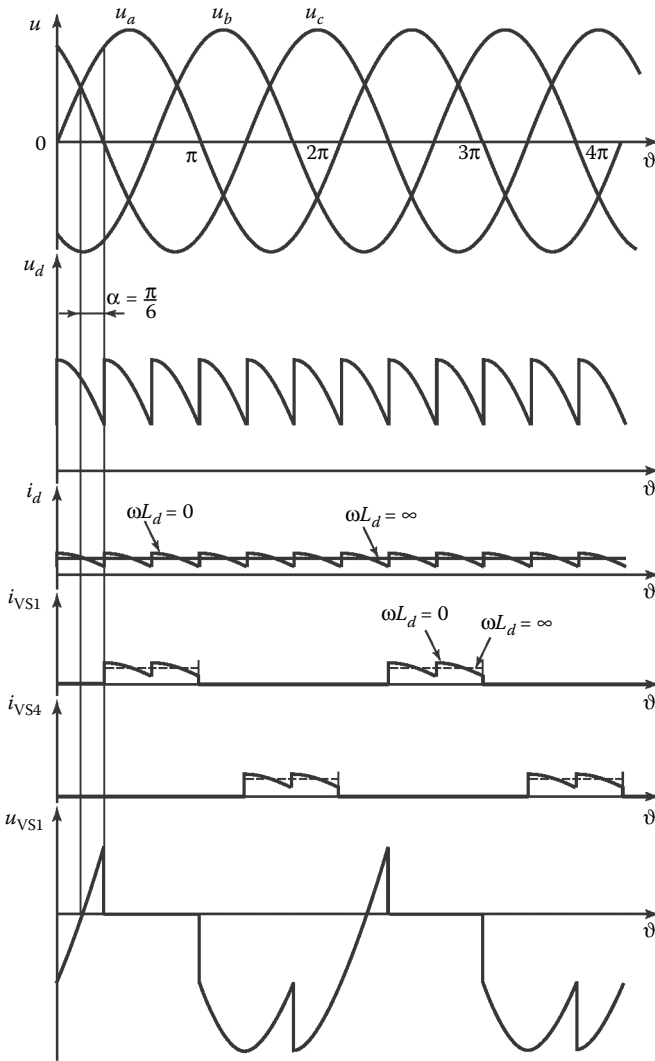

Figure 4.14 Voltage and current waveforms for a three-phase bridge rectifier ($\alpha = \pi/6$).

also for initial startup, because the thyristors of the anode and cathode groups must be switched on simultaneously in order to create a circuit suitable for current flow.

Figure 4.16 shows the control characteristics for a three-phase bridge circuit. With variation in α from 0 to $\pi/3$, the control characteristic for an active or active-inductive load is described by Equation 4.27. When

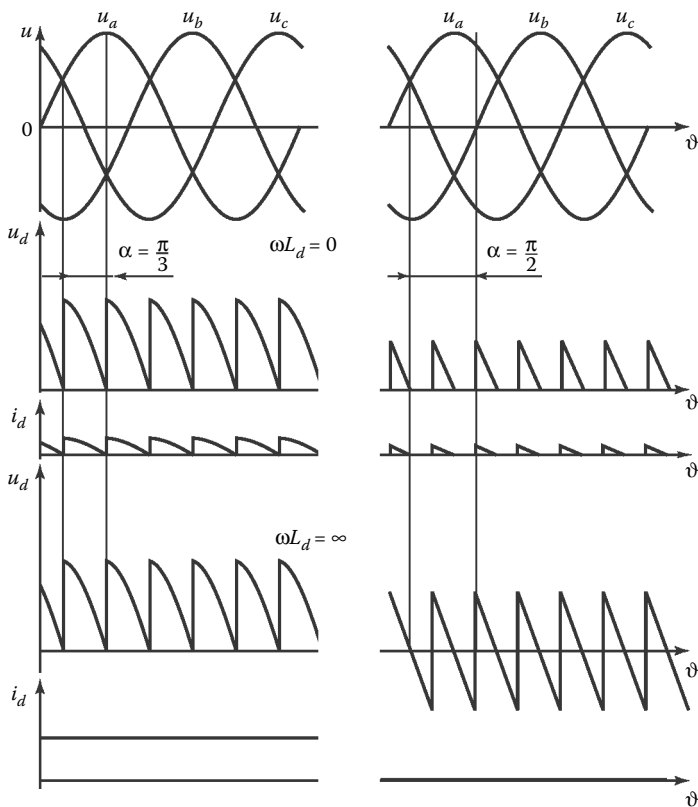

Figure 4.15 Voltage and current waveforms for a three-phase bridge rectifier when $\alpha = \pi/3$ and $\alpha = \pi/2$.

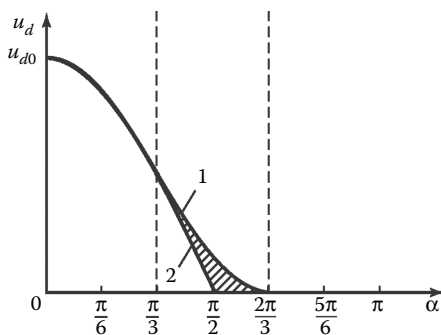

Figure 4.16 Control characteristics for a three-phase bridge rectifier with an active load (1) and an RL load (2).

$\alpha > \pi/3$, with an active–inductive load, current i_d is continuous, and the control characteristic is again described by Equation 4.27. The shaded region in Figure 4.16 corresponds to the family of control characteristics with discontinuous current i_d at different firing angles α .

For high-power rectifiers (above 1000 kW), with high voltage and current, we use multiphase circuits consisting of several bridges in series or parallel.

4.2.2.5 Multiple-bridge circuits

We may distinguish between multiple-bridge circuits with a single transformer and those with two or more transformers coupled in different configurations. The main purpose of multiple-bridge circuits is to reduce the ripple of rectified voltage and to improve the form of the current consumed from the grid, so that it is more sinusoidal.

Figure 4.17 shows two types of two-bridge circuits. The first consists of a three-winding transformer in a star/star–delta configuration and two three-phase bridges. The second includes two two-winding transformers and two three-phase bridges. One transformer is in star/star configuration, and the other in delta–star configuration.

In both cases, the phase shift of the transformer secondary voltages is $\pi/6$.

The two circuits operate analogously. Therefore, we will consider only one in more detail: the circuit with two transformers. As the primary windings of transformers T1 and T2 are in different configurations, there will be a phase shift of $\pi/6$ between the pulsations of the rectified voltage U_{d1} of one circuit and U_{d2} of the other circuit. To balance the instantaneous values of the rectified voltages, the bridges are connected in parallel through a compensating inductor. As a result, the total voltage at the load will have a ripple frequency twice that of each circuit. In the present case, each bridge circuit has six pulsations per period, and the total voltage will have 12 pulsations per period. Therefore, this is sometimes known as a 12-phase circuit. (Likewise, in view of the number of pulsations per period, a three-phase bridge circuit is sometimes known as a six-phase circuit.) The difference in instantaneous voltages is experienced by the equalizing reactor, whose two coils are mounted on a single core. The instantaneous values of the rectified voltage may be written in the form

$$U_d = u_{d1} - \frac{u_p}{2} = u_{d2} + \frac{u_p}{2}, \quad (4.28)$$

where u_p is the instantaneous voltage at the compensating inductor.

Figure 4.18 shows the current waveforms for 12-phase circuits (when $\omega L_d = \infty$). It is evident that the current consumed from the grid is more sinusoidal than that for a single-transformer circuit.

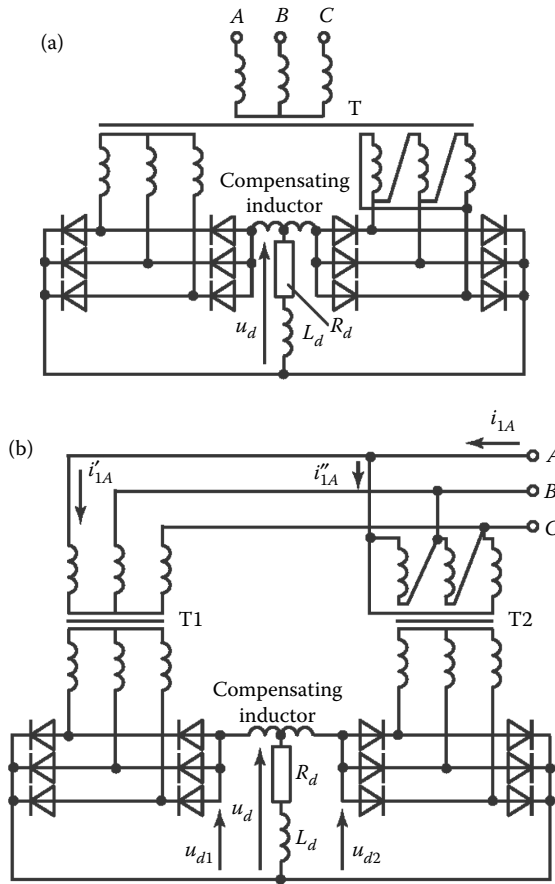

Figure 4.17 A three-phase two-bridge rectifier with parallel bridges.

Note that normal circuit operation requires the selection of the transformation ratios of transformers T1 and T2, so that the average voltages U_{d1} and U_{d2} are equal.

Figure 4.19 shows a two-bridge circuit with the bridges in series. In that case, the average rectified voltage at the load is

$$U_d = U_{d1} + U_{d2}, \tag{4.29}$$

where U_{d1} and U_{d2} ($U_{d1} = U_{d2}$) are the average output voltages of each bridge.

The 12-phase rectification circuit is based on the transformers with different winding configurations.

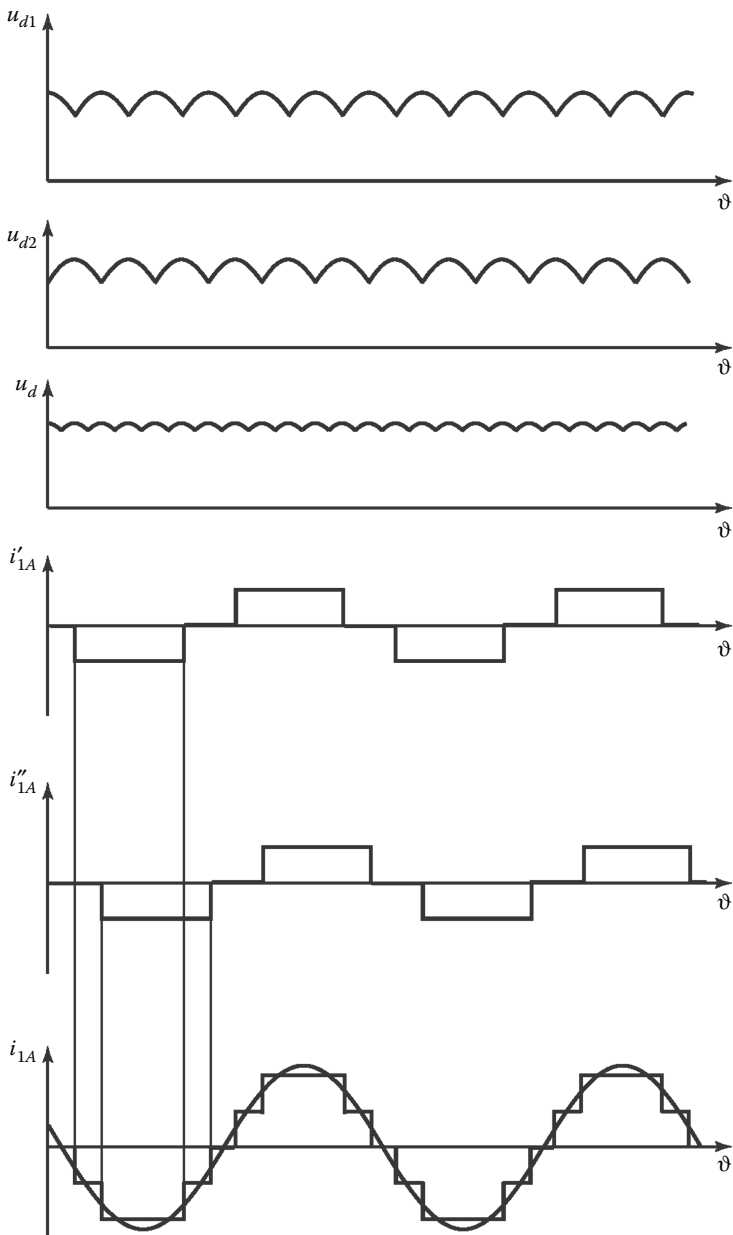

Figure 4.18 Voltage and current waveforms for a two-bridge rectifier.

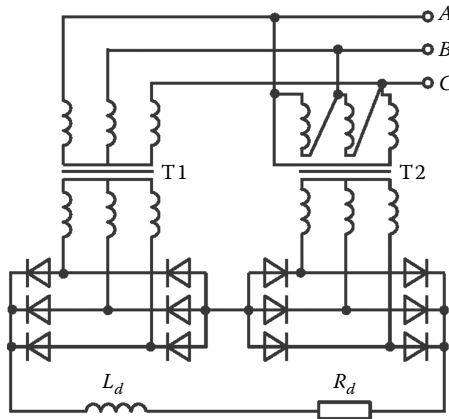

Figure 4.19 A three-phase two-bridge rectifier with series bridges.

In practice, 18- and 24-phase circuits are generally produced, respectively, by connecting three and four bridges in parallel (Rozanov, 1992).

4.2.3 Characteristics of rectifiers

4.2.3.1 Output voltage ripple

The rectified voltage may be represented as the sum of two components: one constant and the other variable. The variable component, in turn, is the sum of harmonic (sinusoidal) voltages

$$u_{-}(t) = \sum_{n=1}^{\infty} U_{nm} \sin(nm \cdot \omega t + \varphi_n), \quad (4.30)$$

where n is the number of harmonics, m the number of pulsations in the rectified voltage within the period of the variable component, ω the angular frequency of the grid voltage, U_{nm} the amplitude of harmonic n , and φ_n the initial phase of harmonic n .

The frequency of the rectified-voltage components is

$$f_n = nf_1 = mnf, \quad (4.31)$$

where f is the frequency of the grid voltage and $f_1 = mf$ is the frequency of the first harmonic of the pulsations.

For example, at a grid frequency $f = 50$ Hz, the frequency of the first harmonic ($n = 1$) takes the following values.

- a. 100 Hz for a single-phase full-wave circuit ($m = 2$)
- b. 150 Hz for a center-tapped three-phase circuit ($m = 3$)
- c. 300 Hz for a three-phase bridge circuit ($m = 6$)

The amplitude of the n th voltage harmonic for a circuit with firing angle $\alpha = 0$ is (Rozanov, 1992)

$$U_{nm} = \frac{2U_d}{m^2 n^2 - 1}. \quad (4.32)$$

According to Equation 4.32, the amplitude of the first harmonic ($n = 1$) is the greatest. The others decline in inverse proportion to n^2 .

The effective value of the variable component in the rectified voltage may be expressed in the form

$$U_{\text{eff}} = \sqrt{\sum_{n=1}^{\infty} U_n^2}, \quad (4.33)$$

where U_n is the effective value of the n th harmonic.

In practice, the ripple (the content of the variable component) in the rectified voltage is estimated on the basis of the ripple factor K_r . The delay α in supplying the control pulses to the thyristors (with respect to the natural commutation times) changes the harmonics in the rectified voltage. It is evident from plots of the rectified voltage that the variable component (the ripple) increases with α rising. However, the period of the ripple pulsations does not depend on α .

4.2.3.2 Distortion of the input current

It follows from the operating principles of the rectifier circuits that they mostly consume nonsinusoidal current from the grid. Only a single-phase full-wave rectifier with an active load, when $\alpha = 0$, consumes sinusoidal current, with zero amplitude of the higher harmonics. With a resistive-inductive load, when $\omega L_d = \infty$, the current is rectangular and may be expressed as the sum of harmonics

$$i_1(\vartheta) = \frac{4I_d}{\pi \cdot k_T} \left[\sin \vartheta + \frac{1}{3} \sin 3\vartheta + \dots + \frac{1}{n} \sin n\vartheta \right], \quad (4.34)$$

where k_T is the transformation ratio.

It is evident from Equation 4.34 that the primary current of the full-wave circuit ($m = 2$) contains only odd current harmonics. The influence of

higher harmonics on the grid is particularly pronounced when the power of the ac source is comparable with the rectifier power.

The harmonic composition of the current consumed from the grid by a controllable rectifier depends significantly on the load. If the load is active or active–inductive but does not ensure continuous current i_d , the amplitude of the higher current harmonics will increase with an increase in α (with constant amplitude of the first harmonic).

With an active–inductive load and ideally smoothed rectified current, the firing angle α has no influence on the harmonic composition of the consumed current. Note that this conclusion assumes zero inductive impedance of the transformer windings.

Usually, passive or active filters are employed to reduce the voltage ripple and the distortion of the rectifier input and output current.

4.2.3.3 *The commutation of the thyristors*

In theoretical analysis, switching of the current from one thyristor to another (commutation) is assumed to be instantaneous. In practice, commutation will have certain duration on account of inductive impedance in the ac circuit—in particular, the impedance of the transformer windings, which is mainly due to scattering fluxes in the transformer's magnetic system.

This impedance is determined in experimental short-circuiting of the secondary transformer windings and is taken into account in circuit analysis on the basis of general (for each phase) equivalent inductances L_s , which correspond to the total inductance of the secondary winding and the reduced (in terms of the number of turns) inductance of the primary winding. In addition to the inductive impedance, the commutation processes also depend on the active impedance of the windings, but to a much smaller degree, in normal conditions. Therefore, in considering commutation, we only take account of the windings' inductive impedance; the rectified current is assumed to be ideally smoothed ($\omega L_d = \infty$). Given that the commutation processes are qualitatively the same in different circuits, we will consider a simple rectifier: a single-phase full-wave circuit.

Figure 4.20a presents the equivalent circuit of a thyristor-based single-phase full-wave rectifier, together with voltage and current diagrams. The inductive impedance of the windings is taken into account by introducing inductance L_s . Suppose that thyristor VS1 is on. At time ϑ_1 , a control pulse is supplied to thyristor VS2. As its anode potential is positive with respect to the cathode at that moment, thyristor VS2 is switched on.

Beginning at time ϑ_1 , both thyristors will be on, and the transformer secondary half-windings short-circuit one another. Under the action of emfs e_a and e_b of the secondary half-windings, the short-circuit current i_{sc} appears in the short-circuited circuit (the commutation loop), which is the

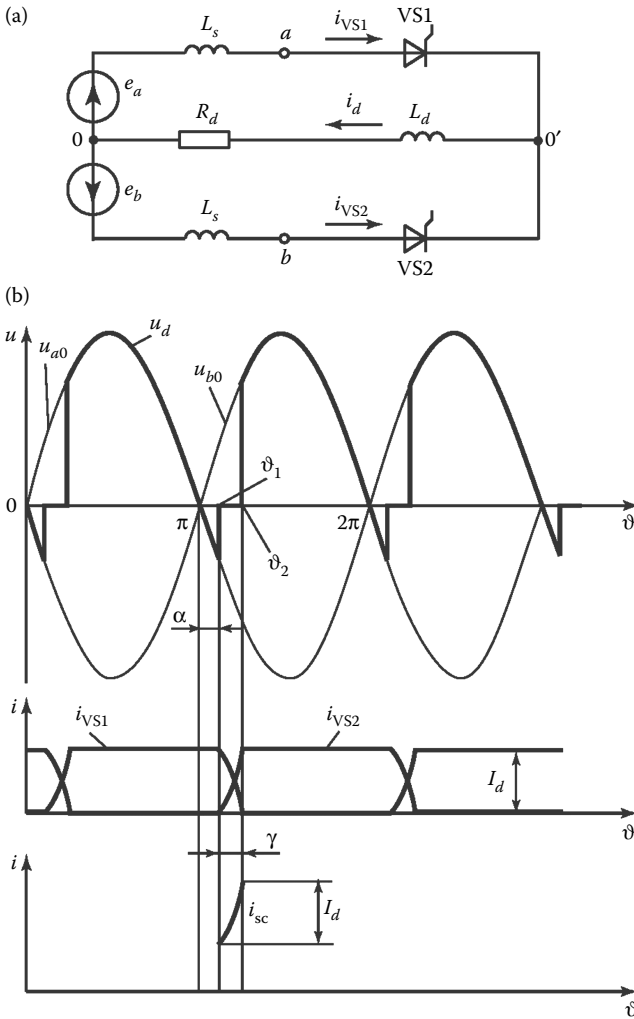

Figure 4.20 (a) Equivalent circuit of a full-wave thyristor rectifier and (b) corresponding voltage and current waveforms.

commutation current. At any time from ϑ_1 on, this current may be determined as the sum of the two components: a steady component i'_{sc} and a free component i''_{sc}

$$i'_{sc} = \frac{2\sqrt{2}}{2x_s} U_2 \cos(\vartheta + \alpha) \quad (4.35)$$

and

$$i''_{sc} = \frac{\sqrt{2} \cdot U_2}{x_s} \cos \alpha, \quad (4.36)$$

where U_2 is the effective voltage of the secondary half-winding and $x_s = \omega L_s$.

Taking account of Equations 4.35 and 4.36, we may write the resultant short-circuit current in the form

$$i_{sc} = i'_{sc} + i''_{sc} = \frac{\sqrt{2}U_2}{x_s} [\cos \alpha + \cos(\alpha + \vartheta)]. \quad (4.37)$$

When thyristor VS2 is switched on and thyristor VS1 is switched off, the resultant short-circuit current i_{sc} runs from the half-winding b with higher potential to the half-winding a with lower potential. As the rectified current remains constant in the commutation period when $\omega L_d = \infty$, we may write the following current equation for point 0 as

$$i_{VS1} + i_{VS2} = I_d = \text{const}, \quad (4.38)$$

where I_d is the average rectified current or load current.

Equation 4.38 is valid for any time. If the current flows only through thyristor VS1, we obtain $i_{VS1} = I_d$ and $i_{VS2} = 0$. With simultaneous conduction of thyristors VS1 and VS2 (during commutation of the current from thyristor VS1 to thyristor VS2), $i_{VS1} = I_d - i_{sc}$ and $i_{VS2} = i_{sc}$. When the current flows only through thyristor VS2, we obtain $i_{VS2} = I_d$ and $i_{VS1} = 0$.

The length of the commutation interval is characterized by the commutation angle γ , which can be determined from the following equation:

$$I_d = \frac{\sqrt{2}U_2}{x_s} [\cos \alpha - \cos(\alpha + \gamma)]. \quad (4.39)$$

If the value of γ when $\alpha = 0$ is denoted by γ_0 , we can write

$$1 - \cos \gamma_0 = \frac{I_d x_s}{\sqrt{2}U_2}. \quad (4.40)$$

Substituting γ_0 into the initial equation, we obtain

$$\gamma = \arccos[\cos \alpha + \cos \gamma_0 - 1] - \alpha. \quad (4.41)$$

According to Equation 4.41, γ declines with an increase in α . In physical terms, we may say that an increase in α boosts the voltage under which the current i_{sc} in the commutation circuit develops, and hence i_{sc} reaches I_d more rapidly.

Note that the duration of current flow in the thyristors is greater by γ than in the idealized circuit. It is $\pi + \gamma$.

Commutation has a significant influence on the rectified voltage U_d , as the instantaneous rectified voltage in the given circuit falls to zero in the commutation intervals (Figure 4.20b). As a result, the average rectified voltage is reduced by

$$\Delta U_x = \frac{1}{\pi} \int_{\alpha}^{\alpha+\gamma} \sqrt{2} U_2 \sin \vartheta \, d\vartheta. \quad (4.42)$$

From Equations 4.39 through 4.42, we conclude that

$$\Delta U_x = \frac{I_d X_s}{\pi}. \quad (4.43)$$

Taking account of Equation 4.43, we write the average rectified voltage in the form

$$U_d = U_{d0} \cos \alpha - \frac{I_d X_s}{\pi}. \quad (4.44)$$

4.2.3.4 External rectifier characteristic

The rectifier characteristic is the dependence of the average rectified voltage on the average load current: $U_d = f(I_d)$. It is determined by the internal resistance of the rectifier, which results in a decrease in the rectified voltage with an increase in the load. The decrease in the voltage includes components due to the active circuit impedance ΔU_R , the voltage drop in the thyristors ΔU_{VS} , and the inductive impedance ΔU_x that appears in commutation.

Correspondingly, the rectifier characteristic (when $\omega L_d = \infty$) may be written in the form

$$U_d = U_{d0} \cos \alpha - \Delta U_R - \Delta U_{VS} - \Delta U_x. \quad (4.45)$$

According to Equation 4.45, the rectifier's output voltage declines with an increase in the load current I_d on account of the internal voltage drop. The influence of the active and reactive circuit components will depend on the rectifier power. Usually, the active impedance of the

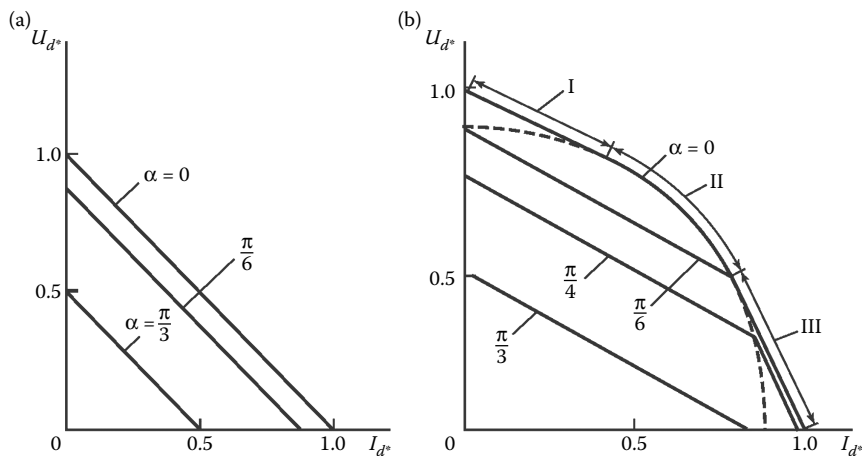

Figure 4.21 (a) External characteristics for a single-phase rectifier and (b) a three-phase bridge rectifier in different operating conditions (I–III).

transformer windings predominates in low-power rectifiers, whereas the transformer's inductive scattering impedance predominates in powerful rectifiers.

Note that, at loads not exceeding the rated value, as a rule, the rectifier's internal voltage drop is not more than 15%–20% of the voltage. However, in the case of overloads and proximity to short-circuits, the internal impedance of the circuit becomes significant. In addition, with overloads in three-phase and multiphase circuits, qualitative changes are observed in the electromagnetic processes that affect the rectifier characteristic. In Figure 4.21, as an example, the characteristics of single-phase and three-phase rectifiers are presented.

4.2.3.5 Energy characteristics of rectifiers

The power factor and efficiency of a rectifier require careful interpretation. We must distinguish between its output power, in which the ripple of the rectified voltage is taken into account, and the power determined by the average output voltage U_d and load current I_d . The latter is usually regarded as the useful power and therefore employed in calculations. When the ripple is slight, the difference between these two quantities may be ignored.

The main losses of active power occur in the following components of power rectifiers: in the transformer (ΔP_T), in the thyristors (ΔP_{VS}), and in auxiliary equipment such as control, safety, cooling, and monitoring systems (ΔP_{aux}). Accordingly, we may calculate the efficiency in the following form for a rectifier with small current pulsations

$$\eta = \frac{U_d I_d}{U_d I_d + \Delta P_T + \Delta P_{VS} + \Delta P_{aux}} \tag{4.46}$$

For the moderate- and high-power rectifiers manufactured today, the efficiency is 0.7–0.9.

The power factor is the ratio of the active power to the total power. It permits the determination of the total power consumed by a power converter if its active load power and efficiency are known. In determining the rectifier power factor, we must take account of the nonsinusoidal component of the power that it draws from the grid. Figure 4.22 shows the grid voltage u_c and grid current i_c consumed by a single-phase controllable rectifier, on the assumption that the rectified current is ideally smoothed and there is no commutation angle. An analysis of the nonsinusoidal current yields the first harmonic i_{c1} , which lags the voltage u_c by φ_1 . Correspondingly, the active power P consumed by the rectifier may be expressed as

$$P = U_s I_{s1} \cos \varphi_1, \tag{4.47}$$

where U_s is the effective grid voltage at the rectifier, I_{s1} the first effective harmonic of the current drawn from the grid, and φ_1 the phase shift of the first current harmonic with respect to the grid voltage.

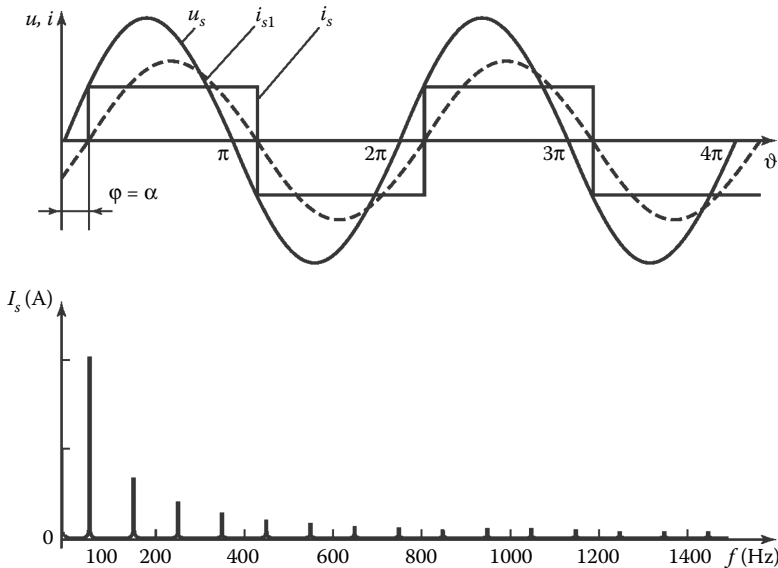

Figure 4.22 Current waveform for a single-phase bridge rectifier ($L_d = \infty$) and its spectrum analysis.

On the basis of the general definition, we can write the apparent power consumed by the rectifier in the form

$$S = U_s I_s = U_s \sqrt{I_{s1}^2 + \sum_{n=3}^{\infty} I_{sn}^2}, \quad (4.48)$$

where I_s is the effective nonsinusoidal current drawn from the grid and I_{sn} is the effective value of its n th harmonic.

According to Equations 4.47 and 4.48, the power factor of the rectifier can be expressed in the form

$$\chi = \frac{P}{S} = \frac{I_{s1} \cos \phi_1}{\sqrt{I_{s1}^2 + \sum_{n=3}^{\infty} I_{sn}^2}}. \quad (4.49)$$

Controllable rectifiers are characterized by a firing angle α , which is equal to the phase shift of the first current harmonic with respect to the grid voltage, as a rule. Hence, for circuits with ideally smoothed current, according to Equation 4.49, the power factor may be calculated in the form

$$\chi = v \cos \alpha. \quad (4.50)$$

For nonsinusoidal current, we must consider not only the active power P and the reactive power Q but also the distortion power T (Chapter 1).

4.3 Grid-tie inverters

4.3.1 Operating principle

Inversion is the conversion of dc electrical energy to ac energy. Linguistically, the term comes from the Latin *inversio*, which signifies overturning. It was introduced in power electronics to denote the process inverse to rectification. In inversion, the flux of electrical energy is reversed and supplied from the dc source to the ac grid. Such a converter is said to be a grid-tie inverter, as it is switched under the action of the alternating voltage in the external grid. As the electrical parameters of the converter are completely determined by the parameters of the external ac grid in this case, it is sometimes referred to as a dependent inverter.

We will consider the operating principle of the grid-tie inverter for the simple example in Figure 4.23a. We assume that the circuit components are ideal, and the internal resistance of the storage battery is zero.

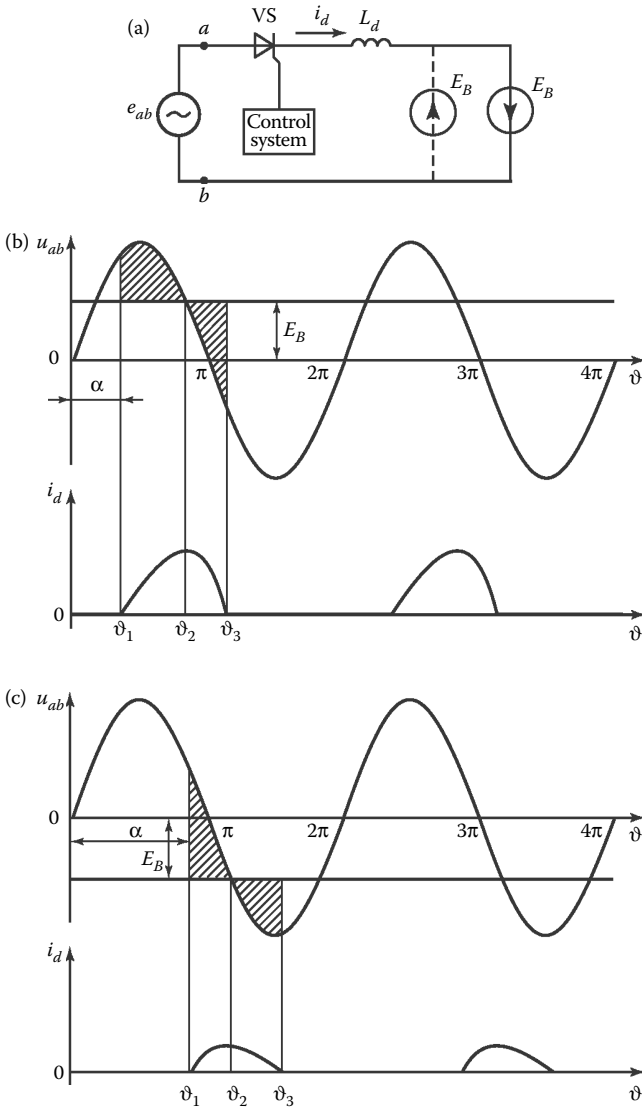

Figure 4.23 (a) A half-wave reversible converter and its voltage and current waveforms in (b) rectifier mode and (c) inverter mode.

Figure 4.23b shows voltage and current waveforms, illustrating the operation of the circuit in the rectifier mode. Under the assumption that the internal resistance of the ac and dc sources is zero, we may conclude that their voltages are equal to the emfs: $e_{ab} = u_{ab}$ and $E_B = U_B$. If the positive terminal of the battery is connected in accordance with the dashed

line in Figure 4.23, the circuit may operate in the rectifier mode with a counter-emf load, which corresponds to battery charging. With reversal of the battery potential, an operation in the inverter mode is possible. We now consider these processes in more detail.

If a control pulse is supplied to the thyristor at time $\vartheta = \vartheta_1$, determined by firing angle α , the thyristor is switched on. As a result, the supply of current i_d from the grid to the battery begins. Due to the smoothing reactor L_d , the current i_d will vary smoothly over time: it increases when $u_{ab} > U_d$ and decreases when $U_d > u_{ab}$. At time ϑ_3 (when the shaded areas in Figure 4.23b are equal), current i_d is zero and thyristor VS is switched off. The passage of current i_d through the thyristor in the interval from ϑ_2 to ϑ_3 , when $U_d > u_{ab}$, is due to the electromagnetic energy stored in the reactor L_d . Subsequently, these processes repeat periodically. As a result, the battery is charged by the rectified current. (Current i_d opposes the emf E_B .)

For conversion of the circuit to the inverter mode, the battery polarity must be reversed.

Energy is transferred from one source to another when the current from the source opposes the emf of the source that is receiving this energy. In the present case, energy will be transferred to the grid from the battery when the grid emf e_{ab} opposes the current i_d . Voltage and current waveforms for the inverter mode are shown in Figure 4.23c. If a control pulse is supplied to thyristor VS at time ϑ_1 , the thyristor is switched on, under the action of a positive forward voltage. The forward voltage at the thyristor exists until time ϑ_2 . Thereafter, the voltage u_{ab} will exceed the emf E_B in an absolute value. Under the action of the voltage difference $U_B - u_{ab}$, the current i_d will flow in the circuit, in the direction opposite to the grid voltage u_{ab} . The smoothing reactor L_d in the circuit limits the rate of increase and the maximum value of i_d . Due to the energy stored in the reactor, current continues to flow in the thyristor after the voltage u_{ab} exceeds U_d in absolute value. The current i_d is zero at time ϑ_3 , when the shaded regions in Figure 4.23c are equal in area.

In terms of circuit structure, dependent inverters are not significantly different from controllable rectifiers. Therefore, they may be regarded as reversible converters, capable of transmitting electrical energy from the grid to a dc source (rectifier mode) or from a dc source to the grid (inverter mode). Therefore, such converters are also known as ac–dc converters (International Electrical-Engineering Dictionary: Power Electronics, 1998).

4.3.1.1 Operation in the inverting mode

As already noted, we can switch from the rectifier to the inverter mode and back by reversing the polarity of the ac source relative to the common terminals of the anode and cathode thyristor groups in the bridge circuit.

Figure 4.24a shows the bridge circuit of a single-phase converter. The dashed line corresponds to the connection of the dc source with emf E_{inv}

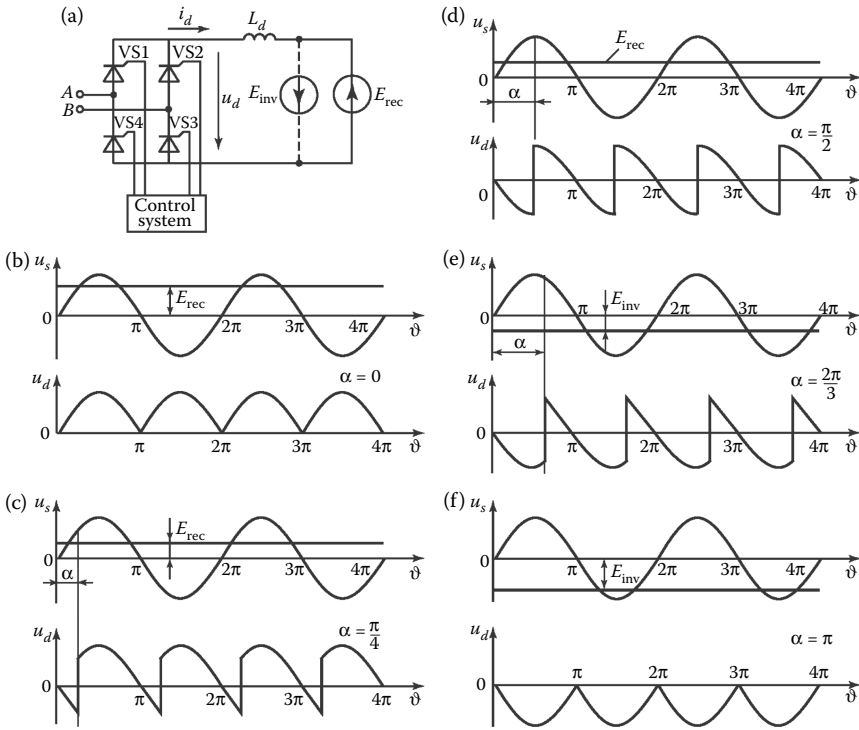

Figure 4.24 (a) A single-phase bridge converter and (b–f) its voltage and current waveforms for rectifier and inverter modes.

in the inverter mode and the continuous line to the connection with emf E_{rec} in the rectifier mode.

We assume that the inductance L_d is relatively large and the dc ripple may be neglected. In other words, we assume that $\omega L_d = \infty$ in the case of steady operation with different values of the firing angle α , which determines when the CS delivers the current pulses to the thyristors.

Figure 4.24 presents instantaneous values of the voltage $u_d(\vartheta)$ on the dc side of the converter (ahead of the reactor L_d). Under the given assumptions, the emfs in the reactor and the inverter mode are equal: $E_{inv} = E_{rec}$. We consider steady operation, with $\alpha = 0, \pi/4, \pi/2, 2\pi/3$, and π . The current in the reactor L_d is assumed to be equal to the average value of the current I_d , in all steady operating conditions. With variation in α as in Figure 4.24, this will be the case if the voltage of the dc source (consumer) also varies in accordance with the firing angle α .

In Figure 4.24, the angles $\alpha = 0$ and $\pi/4$ correspond to the rectifier mode. When $\alpha = \pi/2$, the average voltage on the dc side of the converter is $U_d = 0$, and the current I_d stored in the reactor L_d remains constant in

view of our assumption that there are no power losses in the circuit components. As a result, when $\alpha = \pi/2$, reactive power is exchanged between the ac sources and the reactor L_d . When $\alpha = 2\pi/3$ and π , the average voltage U_d reverses the sign (so as to oppose current I_d). This corresponds to the inverter mode, that is, transfer of energy flux from the source E_{inv} through the converter's thyristor bridge to the ac grid. Figure 4.25 presents the grid voltage and inverter input current i_s on the grid side, which alternates slightly under the given assumptions. If we only consider the first harmonic of this current, we can plot vector diagrams for different operating conditions (Figure 4.26). We see that a thyristor-based ac/dc converter with natural commutation may operate in two quadrants of the complex plane, corresponding to possible vector values of the first current harmonic.

It is evident from Figure 4.26 that, on switching to the inverter mode, α becomes greater than $\pi/2$. In that case, the thyristor converter produces alternating current from direct current and transfers the energy of a dc source with emf E_{inv} to the grid. On the dc side (ahead of the reactor L_d), an inverter emf with the polarity opposite to the rectifier emf is formed.

4.3.2 Basic circuits operation in the inverting mode

4.3.2.1 Single-phase bridge inverter

An inverter bridge circuit is shown in Figure 4.27a. Suppose that thyristors VS1 and VS3 are conducting. In that case, energy from the dc source E_{inv} is sent through the transformer to the grid, because current i_s in the primary winding of transformer T opposes the voltage there u_{ab} . On the assumption that $L_d = \infty$, the voltage pulsation due to the difference in instantaneous voltages of the secondary transformer windings and the dc source will be applied to the reactor L_d .

To ensure inverter mode, the firing angle α must be greater than $\pi/2$. Therefore, in the circuit analysis, the control angle in the inverter mode is usually measured with respect to the natural commutation times in circuits with uncontrollable diodes (or to the angles $\alpha = 0, \pi, 2\pi$, etc. in circuits with thyristors). The angle measured in this way is the lead angle β . The relation between β and α is as follows:

$$\beta = \pi - \alpha. \quad (4.51)$$

Suppose that thyristors VS2 and VS4 conduct in the interval from 0 to ϑ_1 . At time ϑ_1 , control pulses are sent to thyristors VS1 and VS3. At that moment, the thyristor anode is positive relative to the cathode ($u_{\text{ab}} > 0$), and so the thyristors are switched on. The secondary transformer winding is short-circuited. As a result, the short-circuit current i_{sc} appears, opposing the current through the thyristors. In other words, natural commutation begins. When commutation ends at time ϑ_2 (as in the rectifier mode, the

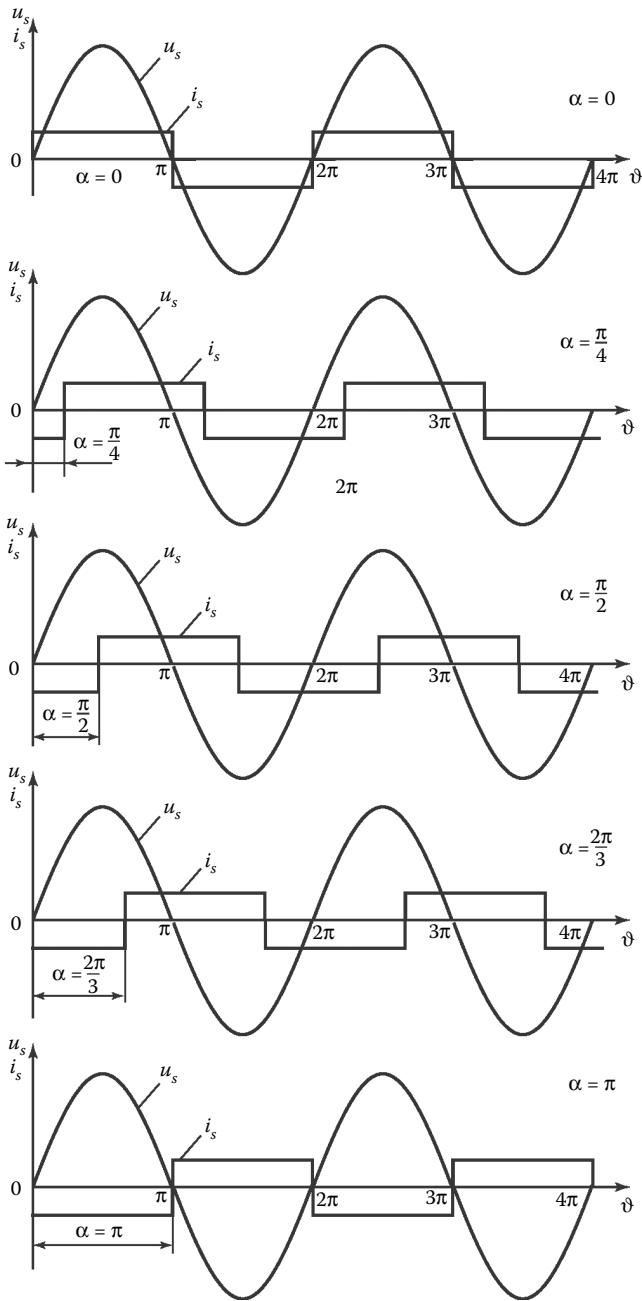

Figure 4.25 Source voltage and consumption current waveforms for a single-phase bridge converter in different values of firing angle α .

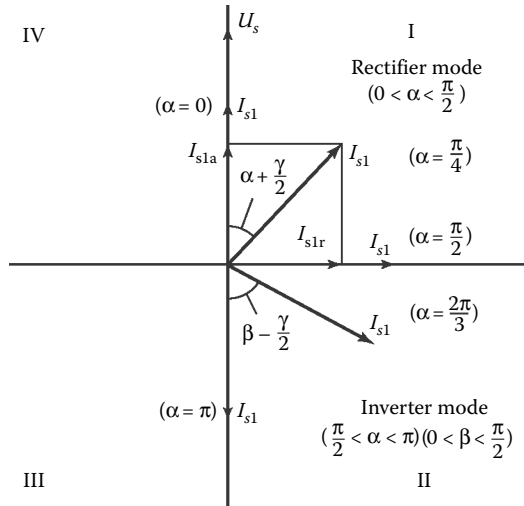

Figure 4.26 Vector diagram for a thyristor-based converter (rectifier and inverter operation).

duration of commutation is expressed by the angle γ), the thyristors are switched off; the inverse voltage u_{ab} is applied to them. As a result, thyristors VS2 and VS4 are able to recover their switching properties until u_{ab} changes sign (when the potential is greater at point b than at point a). The angle corresponding to this interval is the reserve angle δ . The relation between β , γ and δ is as follows:

$$\beta = \gamma + \delta. \tag{4.52}$$

Thyristors VS1 and VS3 conduct up to time ϑ_4 . Before that, at time ϑ_3 , control pulses are sent to thyristors VS2 and VS4. As a result, commutation occurs and thyristors VS2 and VS4 are switched on, whereas thyristors VS1 and VS3 are switched off. At that point, the processes periodically repeat.

It is evident from the form of the electromagnetic processes that they are largely similar to rectifier operation with a counter-emf. The main difference is that, in the inverter mode, the dc source is switched on with the opposite polarity to the thyristors and sends energy to the grid. Because the control pulses are sent to the thyristors with lead β relative to the commutation times (with phase shift π), the current i_s sent to the grid passes through zero to positive values before the voltage passes through zero to negative values. Therefore, the first harmonic of the current i_s is ahead of the voltage u_{ab} by an angle of about $\beta - \gamma/2$ (Figure 4.27b).

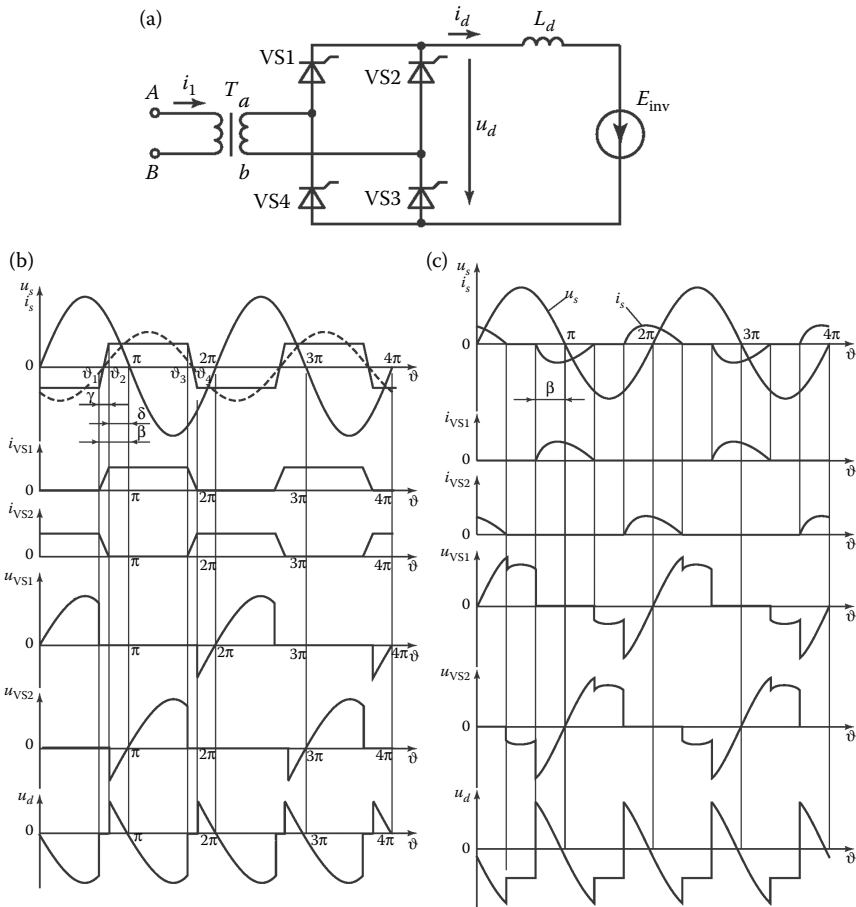

Figure 4.27 (a) A single-phase bridge inverter and voltage and current waveforms in the case of (b) continuous and (c) interrupted load currents.

The vector diagrams of the current i_{s1} and voltage u_{ab} for the rectifier mode and the inverter mode are shown in Figure 4.26. In the rectifier mode, the first current harmonic lags the voltage by about $\alpha + \gamma/2$. It is evident from the vector diagram that, in the inverter mode, the active current component I_{s1a} opposes the grid voltage. This corresponds to the supply of active power to the grid. As in the rectifier mode, the reactive current I_{s1r} lags the grid voltage by $\pi/2$. Hence, in both cases, the converter is a consumer of reactive power. The voltage on the dc side of the converter, known as the counter-emf of the inverter, has pulsations, depending on the angles β and γ . The relations for these pulsations are the same as for the rectifier mode if α is replaced by β . The average voltage U_d is equal to the source voltage E_{inv} .

The relation between the effective voltage U_{ab} at the secondary transformer winding (which depends on the ac grid voltage and the transformation ratio) and the dc source voltage U_d is similar to that for the average rectified voltage of a rectifier. With no inverter load, we obtain

$$U_{d0} = \frac{2\sqrt{2}}{\pi} U_2 \cos \beta, \quad (4.53)$$

where U_2 is the effective voltage at the secondary transformer winding.

The other relations are also similar to those in Section 4.2.2 for a resistive–inductive load of a single-phase rectifier with a continuous reactor current. In the case of discontinuous current i_d (Figure 4.27c), the analytical relations between the circuit parameters are considerably complicated, as in the rectifier mode.

4.3.2.2 Three-phase bridge inverter

Figure 4.28 shows a thyristor-based three-phase bridge inverter, together with voltage and current waveforms in the case of ideally smoothed current I_d . In this circuit, as in a single-phase bridge inverter, control pulses are sent to thyristors with lead β relative to the times corresponding to the onset of thyristor commutation in an uncontrollable rectifier mode ($\alpha = 0, \pi, 2\pi$, etc.). At those times, the line voltages of the secondary transformer windings pass through zero; in other words, the sinusoidal phase voltages u_a, u_b , and u_c intersect. In the interval $\vartheta_0 - \vartheta_1$, under the action of the source voltage U_d , the current I_d flows through the thyristors VS1 and VS2 and the secondary transformer windings (phases a and c). The instantaneous counter-emf of the inverter (Figure 4.28b) is then equal to the difference of u_c and u_a (Zinov'ev, 2003).

At time ϑ_1 , determined by the lead angle β , which is specified by the inverter's control signal, a control pulse is supplied to thyristor VS3. This thyristor is switched on. As a result, phases a and b of the secondary transformer windings are short-circuited. The corresponding short-circuit current in those phases opposes the current i_{VS1} in thyristor VS1. In other words, commutation begins, analogous to the processes in a three-phase rectifier bridge circuit (Section 4.2.2). The duration of commutation is γ . The voltage U_d in the commutation interval is calculated as u_c minus the half-sum of voltages u_a and u_b . At the end of commutation, thyristors VS2 and VS3 will transmit current I_d , whereas reverse voltage is applied to the thyristor VS1 for time δ .

Subsequently, the commutation of the thyristors occurs in accordance with their numbering (Figure 4.28b). For each thyristor, the conduction interval is $2\pi/3 + \gamma$.

In both inverter mode and rectifier mode, commutation processes are responsible not only for periodic voltage dips on the dc side, but also

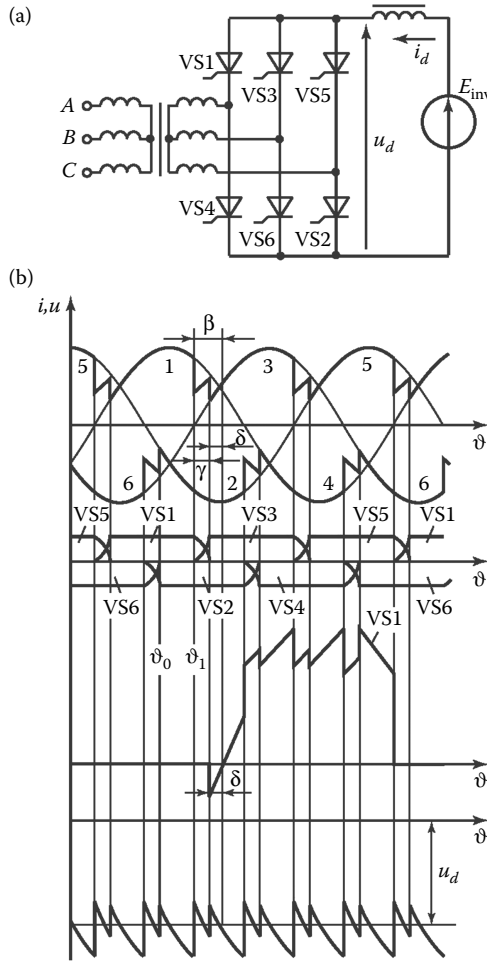

Figure 4.28 (a) A three-phase bridge inverter and (b) its voltage and current waveforms.

for dips and surges in the ac grid voltage. For example, if we assume the equivalent phase inductance (including mainly the transformer’s scattering induction), connected directly to the outputs of the converter circuit in Figure 4.29a, the voltage at the outputs will take the waveform as shown in Figure 4.29b. The areas of the voltage dips and surges may be determined as follows:

$$\Delta S_1 = \frac{X_S}{2} I_d, \quad \Delta S_2 = 2X_S I_d X_S = \omega L_S. \tag{4.54}$$

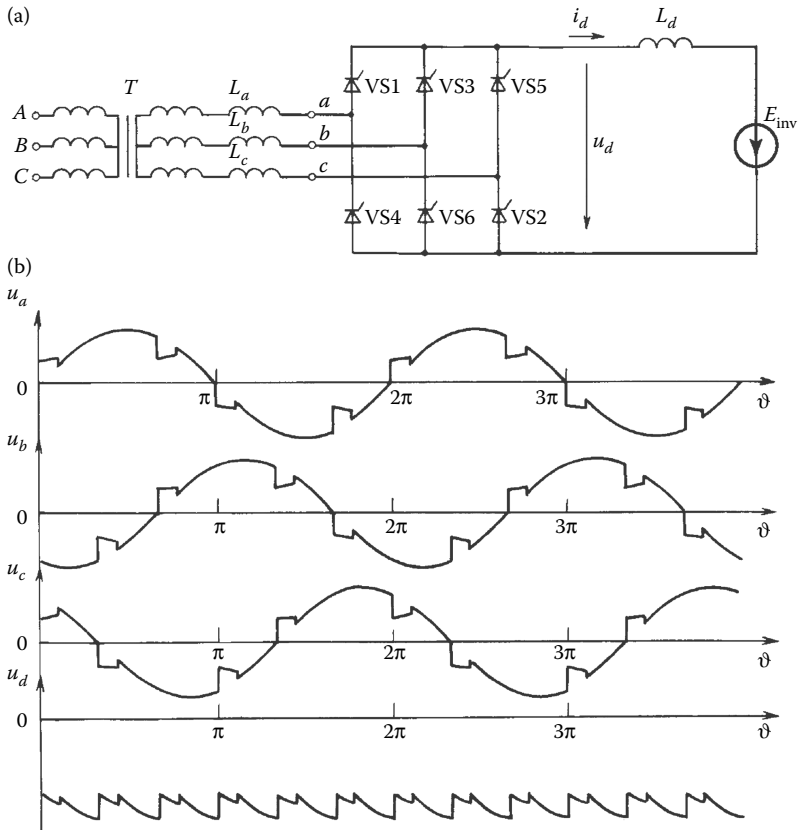

Figure 4.29 (a) A three-phase bridge inverter with equivalent input inductance and (b) voltage waveforms.

Analogous surges and dips are observed in the rectifier mode (Figure 4.2).

The average source voltage U_{d0} with no load is related to the effective phase voltage U_{ph} at the transformer output as follows:

$$U_{d0} = \frac{3\sqrt{6}}{\pi} U_{ph} \cos \beta. \quad (4.55)$$

The other relations for the inverter mode are similar to those for a three-phase system operating in the rectifier mode in the case of an active-inductive load with continuous current I_d .

4.3.3 Active, reactive, and apparent powers of inverters

In considering the operating principle of the grid-tie inverter, we noted that the first harmonic of the nonsinusoidal grid current is shifted relative to the grid voltage by $\beta - \gamma/2$. As a result, the grid-tie inverter, which transmits the active power from the dc source to the grid, also draws reactive power from the grid. We now consider the power balance in the system consisting of the dc source, a single-phase inverter, and the grid. We assume unit efficiency of the inverter.

The active power consumed by the inverter from the dc source is

$$P = U_d I_d, \quad (4.56)$$

where U_d and I_d are the source voltage and the average current at the inverter input, respectively.

The same power on the ac side (e.g., for a single-phase circuit) may be expressed by the familiar formula if we take into account that the phase shift between the first harmonic of the grid current and the grid voltage is about $\beta - \gamma/2$:

$$P = U_s I_{s1} \cos\left(\beta - \frac{\gamma}{2}\right), \quad (4.57)$$

where U_s and I_{s1} are the effective values of the voltage and the first current harmonic in the grid, respectively.

From Equations 4.56 and 4.57,

$$I_{s1} = I_d \frac{U_d}{U_s \cos \varphi_1}, \quad (4.58)$$

where

$$\cos \varphi_1 \approx \cos\left(\beta - \frac{\gamma}{2}\right).$$

The reactive power of the first current harmonic generated by the grid in the inverter may be expressed in the familiar form as

$$Q = U_s I_{s1} \sin\left(\beta - \frac{\gamma}{2}\right) = P \cdot \tan\left(\beta - \frac{\gamma}{2}\right). \quad (4.59)$$

The inverter also creates higher current harmonics in the grid. For example, for a single-phase center-tap circuit, when $\omega L_d = \infty$, if we neglect the commutation angle γ , the grid current is rectangular and may be described by the harmonic series as

$$i_s = \frac{4I_d}{\pi} \left(\sin \vartheta + \frac{1}{3} \sin 3\vartheta + \frac{1}{5} \sin 5\vartheta + \dots \right). \quad (4.60)$$

The harmonic composition of the primary current is analogous for a circuit operating in the rectifier mode (Section 4.2.3).

The nonsinusoidal form of the current may be assessed in terms of the distortion factor v , which depends on the type of the circuit, the angle γ , the inductance L_s , the average current I_d , and other factors (Rozanov, 2009).

The total (apparent) inverter power S on the ac side is

$$S = U_s I_s = U_s \sqrt{I_{s1}^2 + \sum_{n=3}^{\infty} I_{sn}^2}. \quad (4.61)$$

Taking account of higher harmonics, we can write the inverter power factor in the form

$$\chi = \frac{P}{S} \equiv v \cos \left(\beta - \frac{\gamma}{2} \right). \quad (4.62)$$

The potential for increasing the power factor by reducing β is constrained by the conditions for natural commutation of the thyristors: the angle $\delta = \beta - \gamma$ must always be greater than a specific value δ_{\min} . This will be discussed in greater detail later.

Note that if the inverter begins to operate with a lag β , rather than a lead β , it becomes a generator of reactive power, rather than a consumer. If we look again at Figure 4.26, we can isolate two regions on the plane of possible variation in the first harmonic vector of the grid current for a converter with natural commutation of the thyristors.

- I. Rectifier mode when the firing angle $\alpha = 0 - \pi/2$, with the consumption of reactive power from the grid.
- II. Inverter mode when $\alpha = \pi/2 - \pi$ ($\beta = 0 - \pi/2$), with the consumption of reactive power from the grid.

4.3.4 Characteristics of inverters

In the analysis of normal inverter operation, it is important to know the inverter's input and boundary characteristics.

The input characteristic is the dependence of the inverter's average input voltage U_d on the average input current I_d .

The inverter's input voltage may be represented by the sum of two components, if we assume zero voltage drop at the thyristors and active impedances in the circuit. The first component is the no-load voltage U_{d0} , which is equal to the input voltage in instantaneous commutation (with $\gamma = 0$). The second component is the average voltage drop ΔU at the commutation intervals. In contrast to rectifiers, for which the voltage drop is subtracted from the no-load voltage, these components are summed in grid-tie inverters

$$U_d = U_{d0} + \Delta U. \quad (4.63)$$

For inverter circuits, U_{d0} and ΔU may be calculated from the relations analogous to those for controllable rectifiers. The voltage drop ΔU depends on the converter's input current: $\Delta U = f(I_d)$. Therefore, the input characteristic of the grid-tie inverter takes the form

$$U_d = \frac{2\sqrt{2}}{\pi} E_2 \cos \beta + \frac{I_d x_s}{\pi}. \quad (4.64)$$

Figure 4.30 shows the input characteristics of a single-phase inverter obtained from Equation 4.64 for different β . We see that, in contrast to the characteristics of a rectifier (shown in the left half-plane of Figure 4.30), these characteristics are ascending: the voltage rises with the current. The rectifier characteristics may be regarded as the continuation of the inverter's input characteristics with the same α and β .

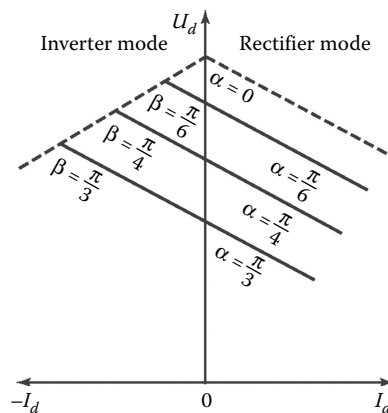

Figure 4.30 Input characteristics of a single-phase converter.

An increase in the input voltage U_d is associated with an increase in the current I_d and hence in the commutation angle γ . In other words, with the constant lead β , the thyristor cutoff angle δ declines. The minimum permissible value δ_{\min} is determined by the frequency of the grid voltage and the type of thyristors. It follows from Equation 4.64 that an increase in β is associated with an increase in the permissible commutation angle γ and, hence, in the current I_d . The limiting permissible value of I_d can be determined as follows.

Suppose that the circuit operates in the rectifier mode and that α is numerically equal to δ_{\min} . At this value of α , the rectifier characteristic is shown by the dashed line in the section of Figure 4.30, corresponding to the rectifier mode. We continue this characteristic in the section corresponding to the inverter mode. (It is again shown by a dashed line.) The intersection of this characteristic with the inverter's input characteristic will determine the inverter's limiting possible operating conditions in terms of I_d , for different β . For a single-phase inverter, these conditions correspond to the equation

$$U_d = \frac{2\sqrt{2}}{\pi} E_2 \cos \delta_{\min} + \frac{I_d x_s}{\pi}. \quad (4.65)$$

As this characteristic indicates the inverter's limiting possible operating conditions, it is known as the boundary characteristic.

The voltage at the converter's dc buses when $I_d = 0$ (with no load) is the same for the rectifier and inverter modes and depends on β (or α). This dependence is usually known as the control characteristic. The converters here considered are reversible. In other words, by adjusting the firing angles and reversing the polarity of the dc source, we may switch between the rectifier mode and the inverter mode. In the rectifier mode, energy is sent from the ac grid to the dc source (which is, thus, a consumer in this case). The reversibility of such converters is utilized in engineering, especially in dc drives.

4.4 Direct frequency converters (cycloconverters)

4.4.1 Thyristor-based ac-ac converters

Frequency conversion involves the production of alternating current of one frequency from alternating current of another frequency. Numerous power electronic frequency converters exist (Zinov'ev, 2003). In the present section, we confine our attention to frequency converters based on thyristors with a natural commutation. Direct frequency converters—converters with a single transformation of electrical energy—are sometimes also known as direct-coupled converters or cycloconverters.

The number of phases of the input and output voltages in direct-coupled converters is of great importance, as it largely determines the converter structure. Note that multiphase direct-coupled converters are characterized by satisfactory performance and are widely used.

We will consider the operating principle of a direct-coupled converter with natural commutation for the example of a three-phase/single-phase circuit (Figure 4.31a). We can identify two groups of thyristors in the

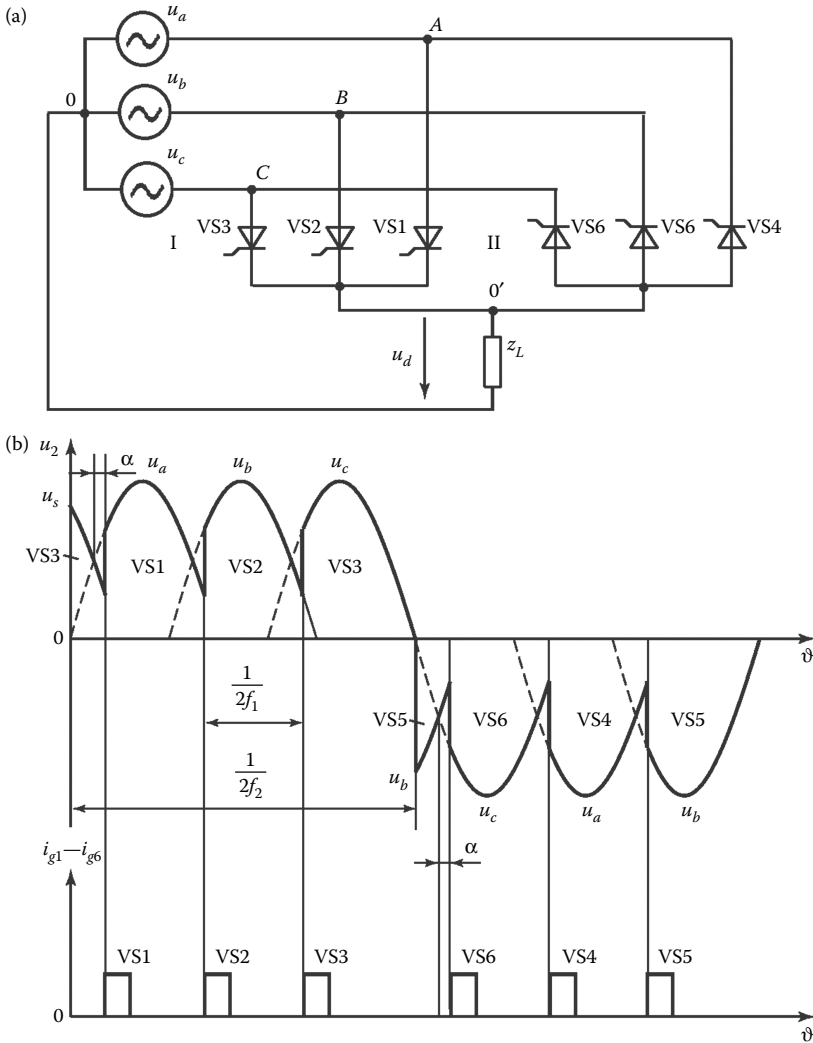

Figure 4.31 (a) A direct-coupled frequency converter and (b) the corresponding voltage waveforms and control pulses in the case of an active load.

converter: cathode group I (VS1, VS2, and VS3) and anode group II (VS4, VS5, and VS6). We assume that the load Z_L is active. In converter operation, control pulses are sent alternately to the anode and cathode groups. When control pulses i_{g1} – i_{g3} , synchronized in frequency with the grid voltage, are sent successively to thyristors VS1, VS2, and VS3 in the cathode group, the system operates in the rectifier mode (as a center-tapped three-phase circuit), and a positive voltage half-wave relative to the transformer tap is formed at the load (Figure 4.31b). The control pulses are sent to the thyristors with a phase shift α relative to the zeros of the grid's line voltage. With the operation of thyristors VS4, VS5, and VS6 in the anode group, a negative voltage half-wave relative to the transformer tap is formed at the load. As a result of the cyclic operation of groups I and II, an alternative voltage with a fundamental frequency f_2 lower than the grid frequency f_1 is created at the load.

The frequency f_2 is determined by the time for which the thyristors of each group are conducting. By adjusting α , the output voltage may be regulated. To eliminate the constant component in the voltage at the load, the operating times of the anode and cathode groups must be equal. The output voltage with an active load is shown in Figure 4.31b. We see that the thyristors of the cathode group operate only after the voltage half-wave formed by the anode group falls to zero and vice versa. That may be explained in that the thyristor is on until its current (in phase with the voltage, in the present case) falls to zero.

In the three-phase/single-phase circuit, commutation within each group (intragroup commutation) lasts for an interval of $\pi/3$. Therefore, if we disregard the commutation interval, we may write the following formula for the length of the output-voltage half-wave:

$$\frac{1}{2f} = \frac{2\pi}{3}n + \left(\pi - \frac{2}{3}(2+1)\right), \quad (4.66)$$

where n is the number of sinusoidal sections in the half-wave and $\pi - 2\pi/3$ is the angle corresponding to zero tail of the output-voltage half-wave.

In general, when the number of grid phases is m , the frequencies of the output voltage f_2 (fundamental frequency) and input voltage f_1 are related as follows:

$$f_2 = \frac{mf_1}{2+m}. \quad (4.67)$$

It is evident from Equation 4.67 that the frequency f_2 of the output voltage may take only discrete values with variation in n ($n = 1, 2, 3, \dots$). For example, with $m = 3$ and $f_1 = 50$ Hz, f_2 may take values of 30, 23.5, 16.7 Hz, and so on. To ensure smooth frequency variation, we need a

pause φ between the end of operation of one group and the onset of operation of the next. In that case, the relation between f_1 and f_2 takes the form

$$f_2 = \frac{f_1 m \pi}{\pi(n + m) + \varphi m}. \tag{4.68}$$

With a resistive-inductive load, the moments at which the output-voltage half-wave passes through zero do not correspond to zero load currents, as the load inductance delays the current relative to the voltage. To ensure that current is sent from the load to the grid in this case (which corresponds to recuperation, the return of the energy stored in the inductance to the grid), the appropriate thyristor group is switched to the inverter mode. For example, if group I operates in the rectifier mode at firing angle α , then, after a specific time, the control pulses are sent to the thyristors of group I with lead β relative to the grid voltage. That pulse sequence corresponds to the inverter mode of the thyristors. In this case, the dc source driving the inverted current is the load or, more precisely, the inductive component of the load. When the group-I thyristors are in the inverter mode, the energy stored in the inductance is returned to the grid and the load current falls to zero. Then the converter CS ensures a pause φ before the group-II thyristors begin to operate in the rectifier mode. Some of those thyristors switch to the inverter mode at a time specified by the control program. Subsequently, these processes repeat periodically.

A direct-coupled three-phase/single-phase converter can be based on two thyristor groups, each with a three-phase bridge configuration. Many direct-coupled circuits produce a three-phase voltage system at the output. Figure 4.32 shows some frequency converters with a three-phase

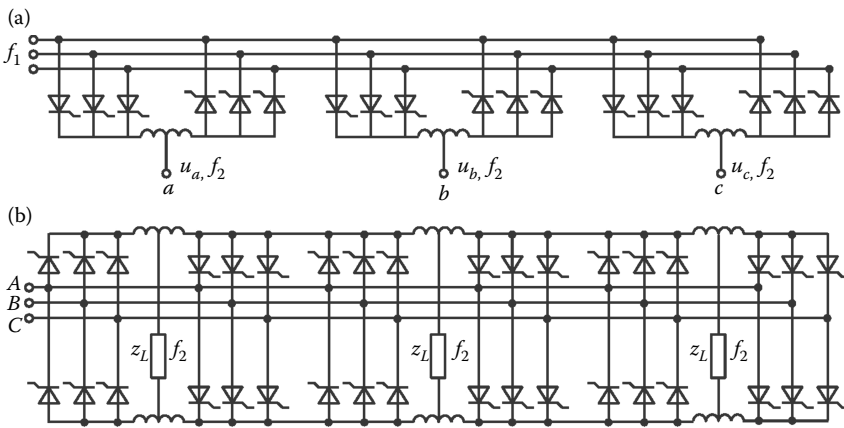

Figure 4.32 A three-phase frequency converter based on (a) center-tapped thyristor groups and (b) bridge groups.

output. In Figure 4.32a, each phase consists of two groups in a three-phase center-tapped configuration; in Figure 4.32b, each phase consists of two groups in a three-phase bridge configuration.

Direct-coupled converters with natural thyristor commutation are relatively simple (at least in terms of the power circuit) and tend to be light and compact. A deficiency is low quality of the output voltage. For example, if each thyristor group operates with constant control angles $\alpha = \beta$ for a half-period, as in Figure 4.32, the output voltage will be seriously distorted, with many higher harmonics. To reduce those harmonics and to ensure a sinusoidal output voltage, regulation of the control angles is required. In addition, the number of pulsations due to thyristor commutation is increased, as in multiphase rectifier circuits.

4.4.2 Reduction of the output-voltage distortion

Usually, converters have an active-inductive load. For such converters, in the case of a continuous output voltage, operation of each thyristor group in both inverter and rectifier modes is required.

As the current conduction in the thyristor groups is unidirectional, the positive wave of the current is formed by group I and the negative wave by group II. Therefore, with an active-inductive load, the current will pass through both groups during each half-period of the output voltage. Figure 4.33, as an example, shows the first harmonics of the current i_L and voltage u_L at the converter output, with a power factor $\cos \varphi$ in the case of an active-inductive load. The interval $0 - \vartheta_1$ corresponds to an inverter mode Π_b , and the current passes through the thyristors in group II. Subsequently, the current begins to pass through the thyristors in group I, which operate in rectifier mode I_a during the interval $\vartheta_1 - \pi$. At time $\vartheta = \pi$, the thyristors in group I switch to inverter mode I_b and so on.

To prevent discontinuity on switching from the rectifier mode to the inverter mode, we employ consistent control of the thyristors.

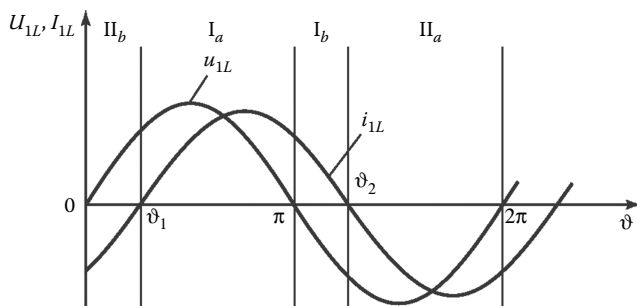

Figure 4.33 Ensuring sinusoidal output voltage in a direct-coupled frequency converter by adjusting the firing angle.

In that case, the delivery of control pulses is such that the thyristors in group I may operate for a single half-period in the rectifier mode with $\alpha \leq \pi/2$, but in the next half-period in the inverter mode with $\alpha = \pi - \beta$. Thyristor group II is prepared for the inverter mode in the first half-period and for the rectifier mode in the second half-period. In such control, considerable balance currents may appear between the two groups. They may be reduced if α and β are selected so that the average voltages in the rectifier and inverter modes are the same, that is, so that $\alpha = \beta$. The balance current due to difference in the instantaneous group voltages is limited by a reactor in the circuit between the two groups.

The output voltage of such a converter is nonsinusoidal, in the general case. Its harmonic composition depends on factors such as the variation in α and β , the number of grid phases, and the frequency ratio of the input and output voltages.

The content of higher harmonics in the output voltage can be reduced if

$$\alpha = \pi - \beta = \arccos(k \sin \omega_2 t), \quad (4.69)$$

where k is the amplitude ratio of the converter's input and output voltages and ω_2 is the frequency of the output voltage.

It follows from Equation 4.69 that, if $k = 1$, α and β must be linear functions of the time. (In that case, the arc cosine becomes a linear function of $\vartheta_2 = \omega_2 t$, which varies from 0 to π .) Figure 4.34 illustrates the control principle more clearly.

In the first half-period (from $\vartheta_2 = \pi/2$ to $\vartheta_2 = \pi$, where $\vartheta_2 = \omega_2 t$), group I is prepared for the rectifier mode, and the control pulses are sent to the thyristors of this group at firing angle α , which varies from 0 to $\alpha - \pi/2$. (Note that the output-voltage half-wave passes through a maximum at $\vartheta_2 = \pi/2$ and through zero at $\vartheta_2 = 0$.) In Figure 4.33, we show the notation for the intervals of thyristor-group operation in the rectifier and inverter modes: I_a and I_b correspond, respectively, to operation of group I in the rectifier and inverter modes during the interval $\pi/2 - \pi$. At this time, the thyristors in group II are prepared for the rectifier mode, with $\beta = 0 - \pi/2$. Likewise, II_a and II_b correspond, respectively, to operation of group II in the rectifier and inverter modes.

In such control, the content of higher harmonics in the output voltage is considerably reduced, as it becomes close to sinusoidal, with some ripple. The ripple diminishes with an increase in the frequency and in the number of grid phases. With an increase in the number of phases (pulsations) in the output voltage, we note a reduction not only in the higher harmonics of the output voltage, but also in the input current of the frequency converter. Figure 4.35 shows output voltage waveforms for 6 and 12-pulse converters with arc cosine control.

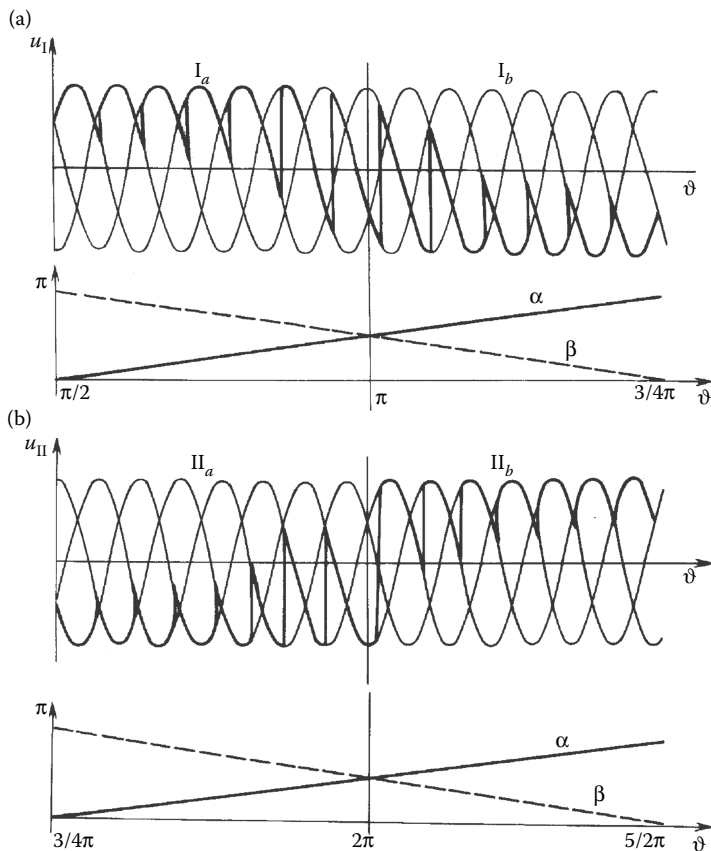

Figure 4.34 Output voltage waveform and firing angle variation for a frequency converter with the operation of thyristor groups (a) I and (b) II.

Note that the power factor of a direct frequency converter is determined not only by the power factor of the load, but also by the ratio of the input and output voltages. With a decrease in the output voltage, the control angles α and β increase, with a consequent decrease in the converter's input power factor. Low input power factor is one of the deficiencies of direct frequency converters with natural thyristor commutation.

4.5 ac voltage regulators based on thyristors

4.5.1 Single-phase ac voltage regulators

According to the IEC definition, an ac thyristor regulator can operate both as a direct ac voltage controller and as an electronic circuit breaker. The

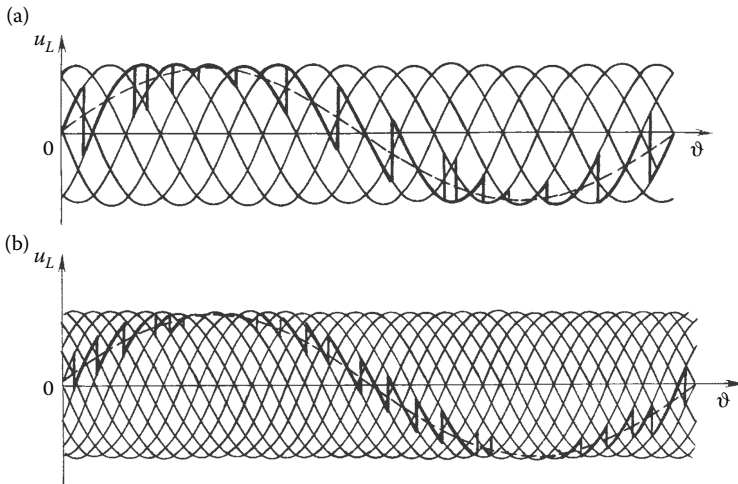

Figure 4.35 Output voltage for a (a) 6-pulse and (b) 12-pulse frequency converter.

function of an electronic circuit breaker is to switch an ac circuit off and on. We now consider regulators based on thyristors with natural commutation in the case of an ac grid.

A single-phase circuit with antiparallel thyristors is shown in Figure 4.36a. This is the basic circuit for thyristor regulators with natural commutation. Obviously, symmetric thyristors may take the place of two opposed thyristors.

We assume that the regulator has an active load. That corresponds to the connection of a resistor R_L to the regulator input. The other circuit components, including thyristors, are assumed to be ideal. In other words, they correspond to the assumptions stated earlier. The thyristors are switched on by the supply of control pulses i_{g1} and i_{g2} to the thyristors' control electrodes. The CS forms the pulses synchronously with the grid voltage $u_s = u_{ab}(\vartheta)$, in a phase corresponding to the firing angle α (Figure 4.36b).

When thyristor VS1 is turned on at time $\vartheta_1 = \alpha$, the input voltage is applied to load resistance R_L . The current i_L in the active-load circuit reproduces the form of voltage u_s . When it falls to zero, thyristor VS1 is switched off. At time $\vartheta_1 = \pi + \alpha$, thyristor VS2 is switched on, and the processes repeat periodically if $\alpha = \text{const}$. We can write the following dependence of the effective output voltage $U_{L,\text{eff}}$ on the firing angle α in the case of an active load

$$U_{L,\text{eff}} = \sqrt{\frac{1}{\pi} \int_{\alpha}^{\pi} (\sqrt{2} U_{ab} \sin \vartheta)^2 d\vartheta} = U_{ab} \sqrt{1 - \frac{\alpha}{\pi} - \frac{\sin 2\alpha}{2\pi}}, \quad (4.70)$$

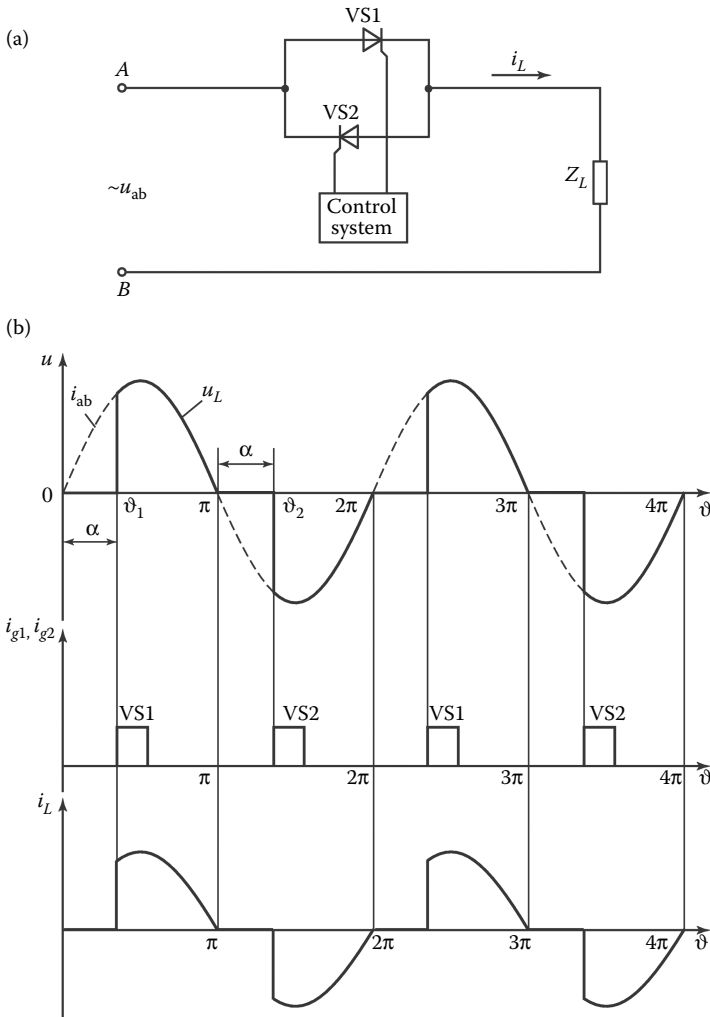

Figure 4.36 (a) An ac regulator based on antiparallel thyristors and (b) voltage and current waveforms.

where U_{ab} is the effective input voltage of the regulator, $\vartheta = \omega t$, and ω is the angular frequency of the grid voltage.

It is evident from Figure 4.36 that adjustment of α from 0 to π permits regulation of the average voltage (and hence also the effective voltage) from the maximum value (equal to the corresponding input voltage) to zero.

Various single-phase regulator circuits are shown in Figure 4.37. Note, in particular, the single-thyristor circuit in Figure 4.37b. However, this

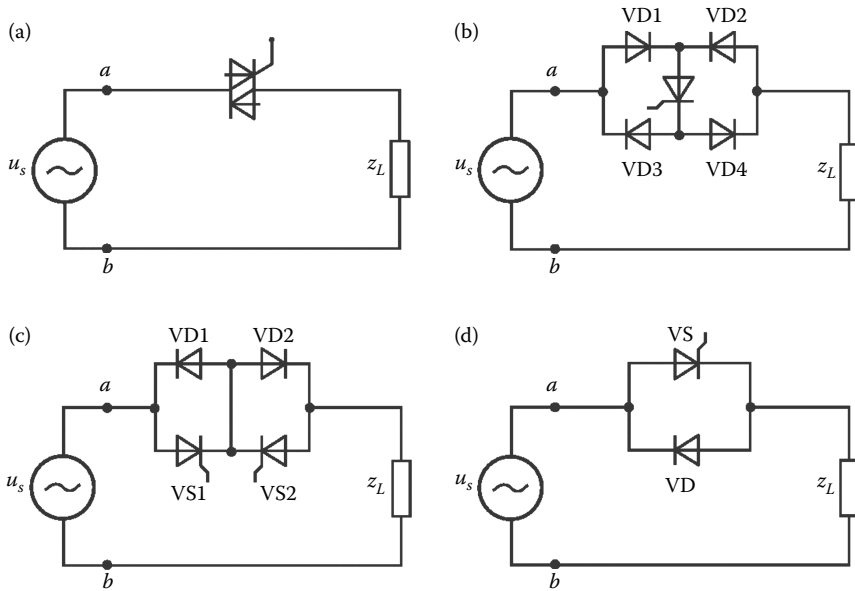

Figure 4.37 Single-phase thyristor regulators: (a) symistor based circuit; (b) single-thyristor circuit with four diodes; (c) circuit based on two thyristors with antiparallel diodes; (d) circuit with thyristor and antiparallel diode.

circuit has a significant drawback. Because the current flows through three semiconductor components (two diodes and a thyristor) in each half-period, the voltage drop will increase, according to the actual volt-ampere characteristics of these components, and hence the power losses will increase. That limits the use of this design at low voltages and low load currents.

The performance of a regulator is largely determined by its control characteristic, which relates the effective output voltage $U_{L,\text{eff}}$ and the thyristor firing angle α . This characteristic depends significantly on the type of load. In the present case, active, active-inductive, and inductive loads are significant. We will consider each in turn.

4.5.1.1 Operation with active load

The dependence of the effective output voltage on the firing angle is described by Equation 4.70. It follows from the regulator operating principle that the output voltage $u_L(\vartheta)$ is nonsinusoidal, and the severity of the higher harmonics depends greatly on α . Figure 4.38 shows the harmonic content as a function of the firing angle α for an active load.

Obviously, an increase in α not only distorts the load current and voltage, but also impairs the input power factor χ , which can be determined

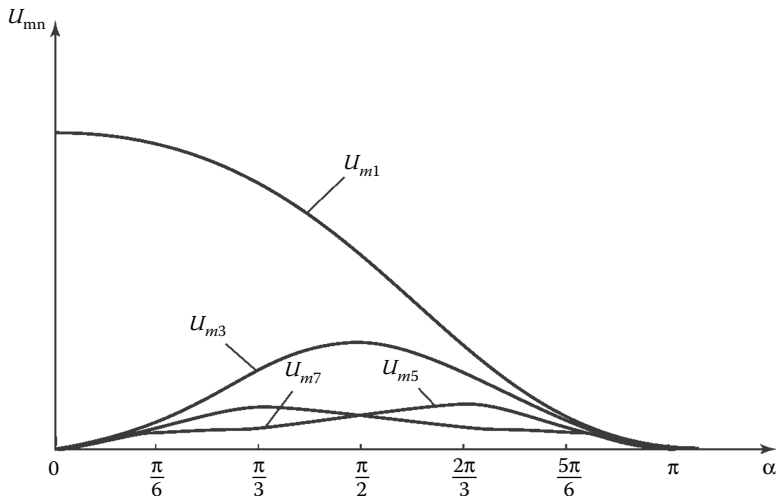

Figure 4.38 Amplitude of the higher harmonics as a function of the firing angle in the case of an active load.

from the series expansion of the current and formulas for the active and total power. The dependence of χ on α for an active load is shown in Figure 4.39.

4.5.1.2 Operation with resistive–inductive load

We assume that the load is a resistor R_L and a reactor (inductance L_L) in series. Turning on any of the thyristors in Figure 4.36a will initiate a transient process in the system consisting of the input-voltage source and the

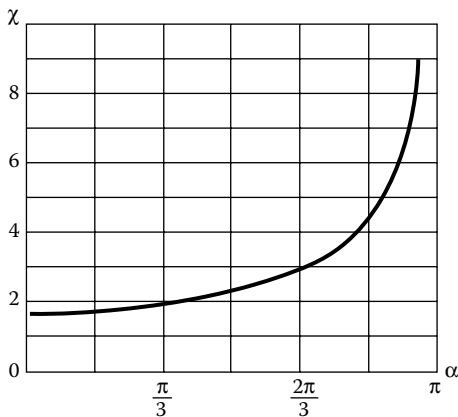

Figure 4.39 Power factor χ of the thyristor regulator as a function of the firing angle for a single-phase regulator with an active load.

load. Under the assumption that the components of the regulator are ideal and also that the input-voltage source is ideal, we may describe the transient process in the form

$$u_{ab}(t) = L_L \frac{di_L}{dt} + i_L R_L, \quad (4.71)$$

where ω is the angular frequency of the voltage source.

The solution is expressed as the sum of a transient component $i_{L, \text{tr}}$ and a steady-state component $i_{L, \text{st}}$:

$$i_L = i_{L, \text{tr}} + i_{L, \text{st}} \quad (4.72)$$

in the form

$$i_L(\vartheta) = \frac{\sqrt{2}U_{ab}}{\sqrt{R_L^2 + (\omega L_L)^2}} \left[\sin(\vartheta - \varphi_L) - \sin(\alpha - \varphi_L) e^{-(\alpha - \vartheta)/\omega\tau} \right]. \quad (4.73)$$

We can distinguish between three types of behaviors of $i_L(\nu)$, depending on α and φ_L :

$$\begin{cases} \alpha > \varphi_L, & \lambda < \pi, & (1) \\ \alpha < \varphi_L, & \lambda > \pi, & (2) \\ \alpha = \varphi_L, & \lambda = \pi. & (3) \end{cases} \quad (4.74)$$

In case (3), there is no transient component $i_{L, \text{tr}}$. Steady-state conditions begin as soon as the thyristor is turned on. In case (2), the transient component extends the first half-wave of the transient process to a duration greater than π . The corresponding conditions in the regulator are such that the second thyristor VS2 will not be turned on at the angle α . Instead, it will be shunted by the first thyristor, which continues to conduct during the second half-period. As a result, regulator operation is asymmetric. That leads to loss of voltage quality and unbalanced thyristor load. These problems may be eliminated by ensuring regulator operation with firing angles $\alpha \geq \varphi_L$.

4.5.1.3 Operation with inductive load

If we assume zero active-power losses in the circuit and in the load, regulator operation with an inductive load differs from operation with an active-inductive load, in that there is no damping of the free component. In symbolic form, the time constant $\tau = L_L/R_L \rightarrow \infty$.

Figure 4.40c shows the equivalent inductance X_{eq} as a function of α . We see that a regulator with input inductance L_0 may be regarded as the controllable inductance of the electronic CS in the range from $X_0 = \omega L_0$ to ∞ .

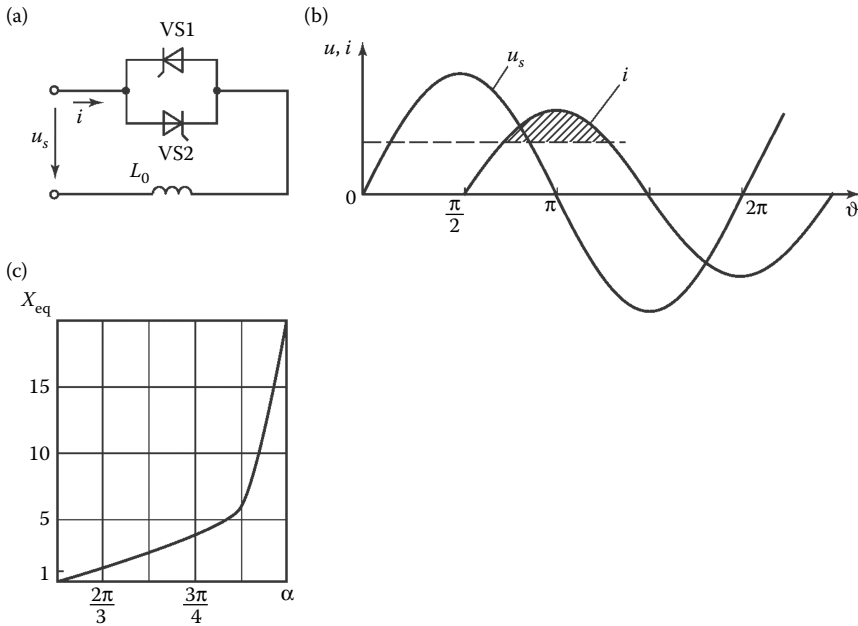

Figure 4.40 A thyristor-based ac regulator with an inductive load: (a) circuit; (b) voltage and current waveforms; and (c) dependence of the equivalent inductance on the firing angle.

This control method is widely used in the power industry for reactive-power compensation in devices consisting of parallel capacitor groups and a resistor antiparallel thyristor.

4.5.2 Three-phase ac voltage regulators

Figure 4.41 shows two characteristic designs for three-phase regulators: with a star configuration of the load and an isolated neutral and with a delta configuration. Switching from a single-phase system to a three-phase system complicates the topology and hence the analysis of the processes in the regulator. Some general laws for the operation of three-phase systems may be obtained for individual control-angle ranges (Williams, 1987). Thus, in the star configuration (Figure 4.41a) with an isolated neutral, three different operational modes of the regulator's thyristors may occur in the case of an active load. We will assume that control pulses are supplied at intervals of $\pi/3$ to the thyristors, in accordance with the numbering in Figure 4.41a. The origin $\vartheta = 0$ is the moment at which the phase voltage passes through zero to positive values. The three thyristor modes are as follows.

- I. When $0 \leq \alpha \leq \pi/3$, only two thyristors are on in some intervals, whereas three thyristors are on in others: for example, VS5 and VS6; then VS5, VS6, and VS1; and so on.
- II. When $\pi/3 \leq \alpha \leq \pi/2$, two thyristors are always on: for example, VS5 and VS6 and then VS1 and VS6.
- III. When $\pi/2 \leq \alpha \leq 5\pi/6$, there are alternating periods in which two thyristors are on and all the thyristors are off. For example, there may be current flow through thyristors VS1 and VS6, but then they are turned off and a period follows in which all the thyristors are off. Then VS2 and VS1 are turned on and so on.

It is evident from these examples that, even for the simplest case of an active load, the processes in the three-phase regulator are considerably

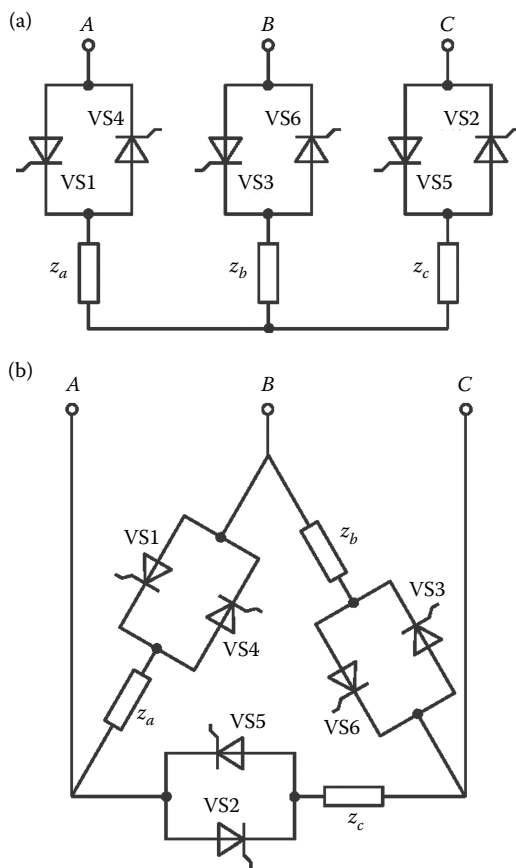

Figure 4.41 Three-phase thyristor regulator circuits: (a) star configuration with an isolated neutral; (b) delta configuration.

more complicated than those in a single-phase regulator. That is also the case for the delta configuration (Figure 4.41b). Note that the regulators with an active-inductive load are most common in practice. In that case, the processes are even more complex, and it is difficult to obtain formulas suitable for practical use. We may note that single-phase regulators are characterized by better spectral composition of the output voltage. In particular, in the delta configuration, current harmonics that are multiples of three do not reach the grid.

To reduce the distortion of the output voltage and output current and also to increase the input power factor χ , voltage stabilization may expediently be based on a thyristor regulator in combination with an autotransformer. Figure 4.42a shows a simplified voltage stabilizer in which the connection to the transformer winding is switched by means of thyristors VS1–VS4. In this system, the output voltage is stabilized by adjusting the switching times. In the positive half-period of the input voltage, thyristor VS1 or VS2 may be on; in the negative half-period, thyristor VS3 or VS4

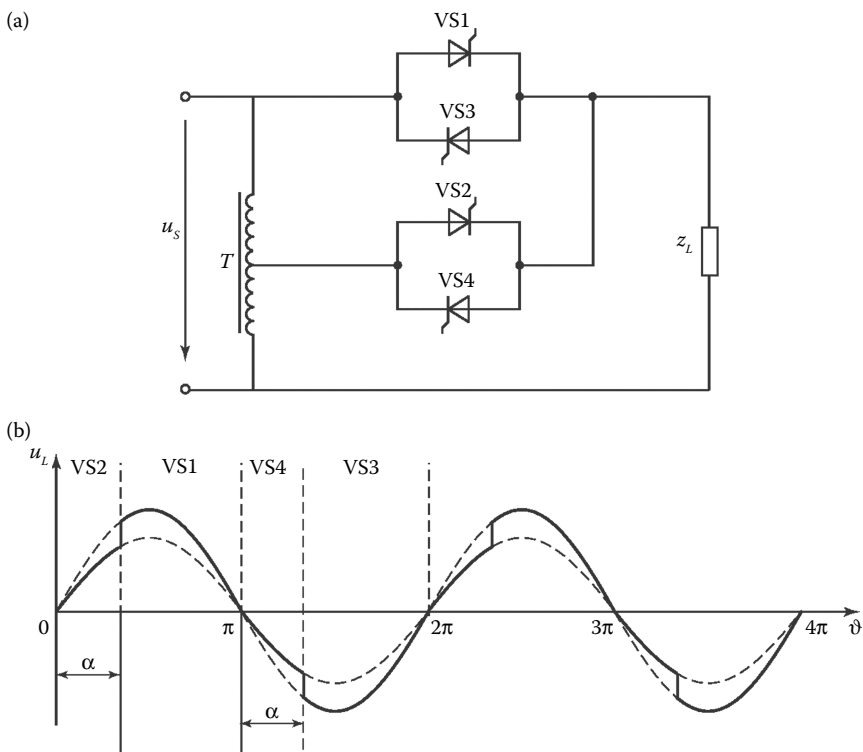

Figure 4.42 (a) A transformer-based voltage stabilizer and (b) its output voltage waveform.

may be on. The commutation of the thyristors in this system depends on the transformer voltage. To ensure natural commutation, switching to the terminals at high potential is required. For example, in the positive half-wave of the output voltage, first thyristor VS2 and then thyristor VS1 will be turned on. In this case, when thyristor VS1 is turned on, a short-circuit is formed. The short-circuit current opposes the load current at thyristor VS2. As a result, thyristor VS2 is turned off, and current begins to flow through thyristor VS1. In this system, the effective value of the output voltage may be regulated by adjusting the switching times of the thyristors. The output voltage of the stabilizer with an active load is shown in Figure 4.42b.

With an active–inductive load, the control of the thyristors is more complicated, because the load current lags the voltage at the transformer winding, and the thyristors are switched off when the load current passes through zero.

References

- International Electrical-Engineering Dictionary, IEC BO050-551. 1998. *Mezhdunarodnyi elektrotekhnicheskii slovar'.* *Power Electronics, Silovaya elektronika, MEK BO050-551.* Moscow: Izd. Standartov (in Russian).
- Rozanov, Yu.K. 1992. *Osnovy silovoi elektroniki (Fundamentals of Power Electronics).* Moscow: Energoatomizdat (in Russian).
- Rozanov, Yu.K. 2009. Power in ac and dc circuits. *Elektrichestvo*, 4, 32–36 (in Russian).
- Rozanov, Yu.K., Ryabchitskii, M.V., and Kvasnyuk, A.A., Eds. 2007. *Silovaya elektronika: Uchebnik dlya vuzov (Power Electronics: A University Textbook).* Moscow: Izd. MEI (in Russian).
- Williams, B.W. 1987. *Power Electronics: Devices, Drivers, and Applications.* New York: John Wiley.
- Zinov'ev, G.S. 2003. *Osnovy silovoi elektroniki (Fundamentals of Power Electronics).* Novosibirsk: Izd. NGTU (in Russian).