

# CLARK MASTS™

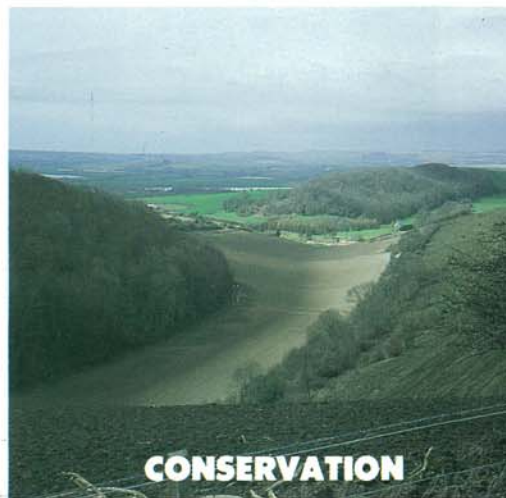

# Models 802/21 & 802/30

These Trailer Mounted Telescopic Clark Masts have an unbelievable range of uses in telecommunications and many fields of scientific study. They are highly mobile, fast and easy for one man to set up practically anywhere, for work which otherwise might be impossible or too expensive. They are long lasting. Earlier models are still in service after 20 years. With the optional equipment now offered, Series 802 is truly a most valuable, flexible and economical tool for all those needing to raise radio antennas and other apparatus up to 30 metres for short periods.

Deze teleskopische Clark Masten hebben enorme toepassingsmogelijkheden op gebied van telekommunikatie en wetenschappelijk onderzoek dank zij hun montage op een zeer mobiele aanhangwagen. Hun robuuste konstruktie en korte opbouwtijd vergemakkelijken vele werkzaamheden die anders onmogelijk of te duur zouden zijn. Ondanks intensief gebruik in dikwijls moeilijke omstandigheden zijn vele modellen reeds 20 jaar in dienst. Met de nu aangeboden uitrusting is de serie 802 een waardevol gereedschap voor iedere toepassing van radio-antennes of meetapparatuur tot op 30 meter hoogte voor een korte termijn.

Diese teleskopischen Masten können für fast alle Telekommunikations- und wissenschaftlichen Zwecke eingesetzt werden. Große Beweglichkeit und schnelle Errichtung, die nur 1 Mann beansprucht, sind dank Montage auf einem Anhänger gewährleistet. Viele Modelle sind bereits 20 Jahre im Dienst, trotz intensiven Gebrauch, oft unter schweren Umständen. Mit angebotenen Zubehör sind die 802-Maste, bis zu 30 Meter kurzfristig errichtet, ein wertvolles und wirtschaftliches Werkzeug für alle Verwendungen von Antennen oder Meßgeräten.

Les mâts Clark, montés sur remorque, sont appréciés dans tous domaines de télécommunication ou recherches scientifiques. Etant très mobiles, un seul opérateur peut les ériger très vite sur n'importe quel terrain. Sa qualité de construction assure une durée de vie exceptionnelle, prouvée par des exemples livrés il y a 20 ans et encore toujours en service. Avec les accessoires présentés, un mât de série 802 est vraiment un outil efficace et économique pour chacun qui doit appliquer jusqu'à une hauteur de 30 mètres des antennes ou appareils scientifiques pour une période courte.



# Some Applications

## Police Temporary Communications Centre

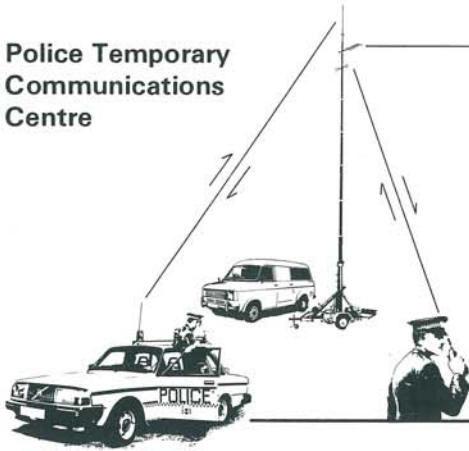

A long-standing application for Trailer mounted Clark Masts is with Police Forces. The mast supports the antenna necessary to link an incident centre to its manpower and its higher authority.

The easy towability of the trailer makes it possible to equip a patrol van as communications centre and give it a 30 metre mast for maximum coverage without sacrificing mobility. No technical staff required for operation.



## Train/Track Communications Repeater Siting

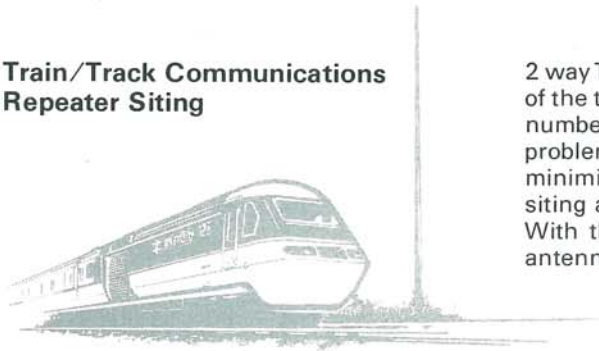

2 way Train/Track Radio Systems require reliable communication over 100% of the track mileage. For various reasons this is best achieved by the use of a number of repeater stations overcoming geographical and topographical problems. Large economies in investment and maintenance are achieved by minimising the number of stations. This calls for optimum relay antenna siting achievable only by practical tests before permanent installation.

With the mobility of the 802 equipment, position and height of optimum antenna siting is easily established.



## Site Surveying Base Station Antenna for Radio Telephone Systems

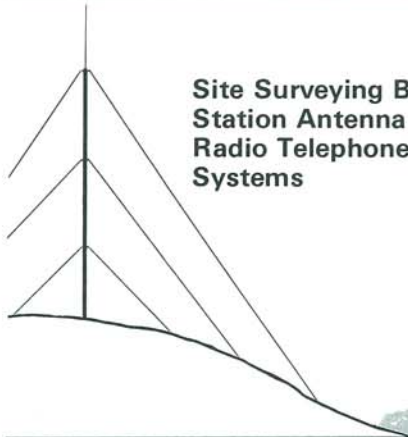

In hilly country or places where there are buildings with bulk, the efficiency of a given 2 way communications system can depend on the positioning and height of the base station antenna.

With one mobile all the optional open sites may be explored and demonstrated before sites are leased or fixed masts erected. Compared with the total value of a wide range system and the reputation of a given marque of equipment, the use of an 802 Trailer Mast makes good economic sense.

## Checking Glide-slope and Localiser at Airport ILS Installations

The use of a 21 metre Clark Mast to check the accuracy and stability of the Glide-slope propagation was developed in collaboration with British Royal Air Forces Signals Command in the early 60's.

Whilst not intended to replace the actual flying of the glide slope and localiser on initial set up and periodic calibration, the system does provide a most useful ground based check of function at the threshold in all weather and visibilities or after pilot-reported problems. Typical total check time on the runway : less than 10 minutes.

Clark Masts does not offer the signal measuring equipment which can be locally produced by using a normal aircraft receiver and indicator. Height is measured by a recently developed improved device.



## DIMENSIONS

Model	A	B	C	D
802/21	21.6 m.	4.84	1.90	1.84
802/30	30.7 m.	5.59	1.90	1.90
802/21 & 802/30	E	F	G	H
	3.30 m.	3.40	.66/.85	0.22

Weight	802/21 802/30	540 kg 660 kg
Towing eye	50mm Ball Socket	
Mast load attachment	Socket 40 mm x 150 deep	
Tyre size	5.90 x 13	

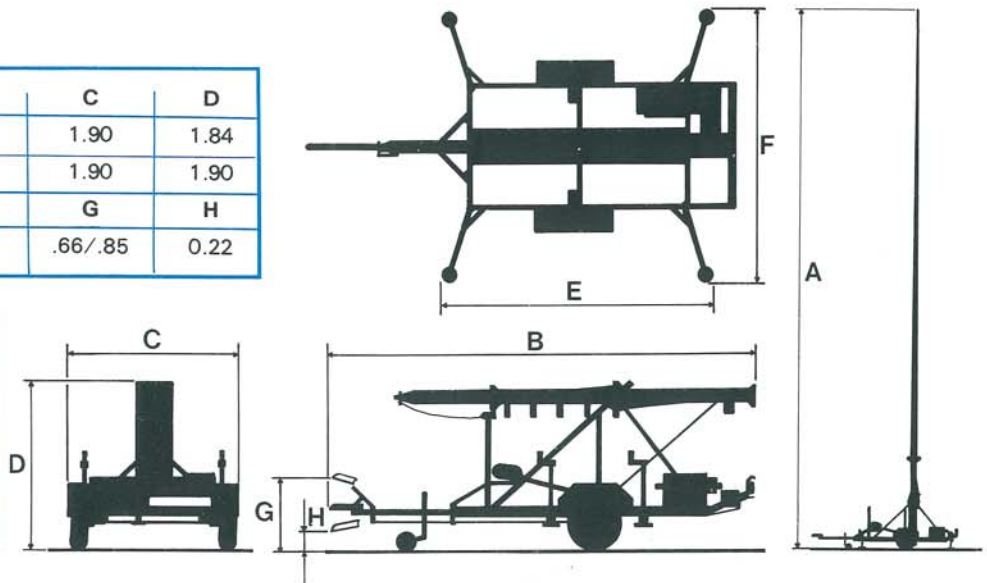

## SHIPPING

Both trailers may be knocked down for shipping, Dimensions as follows :

### Model 802/21

1 case 3050 × 1750 × 750 mm  
weight gross 560 kg  
1 case 4180 × 280 × 280 mm  
weight gross 130 kg

### Model 802/30

1 case 3050 × 1750 × 750 mm  
weight gross 620 kg  
1 case 5150 × 280 × 280 mm  
weight gross 165 kg

Approximate re-assembly time for 2 men : 5 hours

## BRIEF SPECIFICATION

Mast : Light alloy anodised, telescopic, air operated from petrol engine driven vee-twin compressor.

Trailer lighting : Conforming to current EEC Normes.

Mast extension and retraction controlled by single control lever. Mast turnable 360°.

Chassis : All tubular steel welded.

Brakes : Mechanical over-run and handparking.

Finish : Painted to Military Specification.

Standard colour : Yellow RAL1007.

## PERFORMANCE

Headload, maximum recommended	<b>802/21</b> 40 kg	<b>802/30</b> 15 kg	Operating temperature limits : -30° (dry) to +45°C. Minimum operating crew : 1 person.
Time to set up and extend mast	5 min.	8 min.	
Max. windspeed unguyed with 0.5m <sup>2</sup> side area load	35 km/hr	10 km/hr	
Max. windspeed guyed with 0.5m <sup>2</sup> side area load	110 km/hr	80 km/hr	

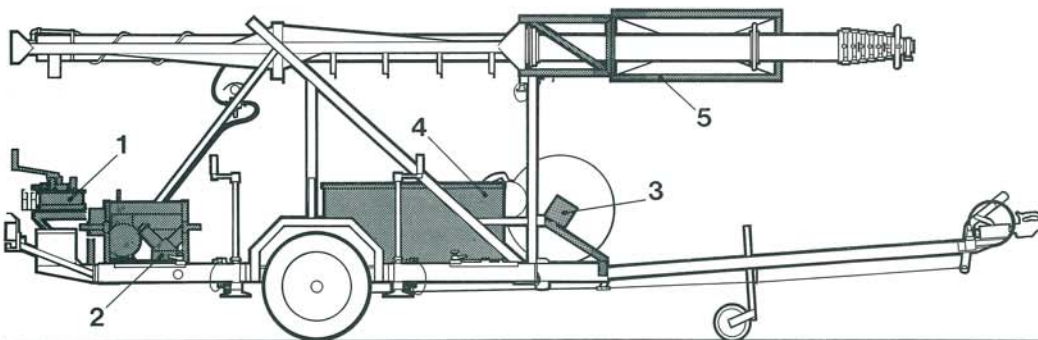

## OPTIONAL ITEMS

1. Winch Unit for Guys (Standard on 802/30).
2. Compressor Unit 230V AC or 12/24V DC.
3. Spare Wheel.
4. Large Equipment Box.
5. Operator Safety Cage (Standard on 802/30).

**NOTE:** This Safety Cage is for a maximum of **1 person only** at any one time.

# CLARK MASTS™

All details in this publication are approximate and may be subject to change without notice.

Distributor :

**CLARK MASTS TEKSAM NV**, Woudstraat 21, B-3600 Genk, Belgium  
Tel : +32 (0)89 38 44 72 - Fax : +32 (0)89 38 61 41 - E-mail : info@teksam.be

CLARK MASTS is a division of Clark Masts Teksam NV

# PIONEER IN FAST ERECTING MAST SYSTEMS