

\$1.25 ■ Mo

Radio-^{IND}Electronics

THE MAGAZINE FOR NEW IDEAS IN ELECTRONICS

Easy to build
BOWLING-ALLEY GAME

How to quick fix
CITIZENS-BAND RADIOS

What's happening in
RECHARGEABLE BATTERIES

Build this
AUDIO TEST STATION

Special roundup
STEREO AMPLIFIERS

Two reports from
R.E.A.L. SOUND LAB

Build for your bench
TIME/VOLTAGE CALIBRATOR



A
GERNSBACK
PUBLICATION



★ HOBBY CORNER
 ★ COMPUTER CORNER
 ★ SERVICE CLINIC ★ STATE-OF-SOLID-STATE

You can't beat The System.

The Experimentor System™ — a quicker transition from imagination through experimentation to realization.

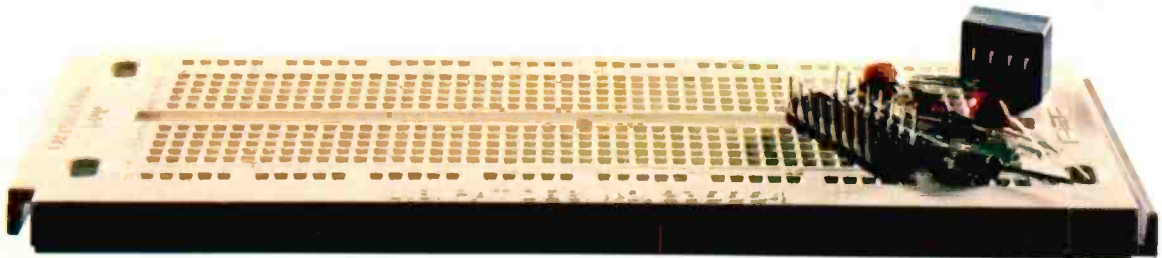

Experimentor solderless breadboard.

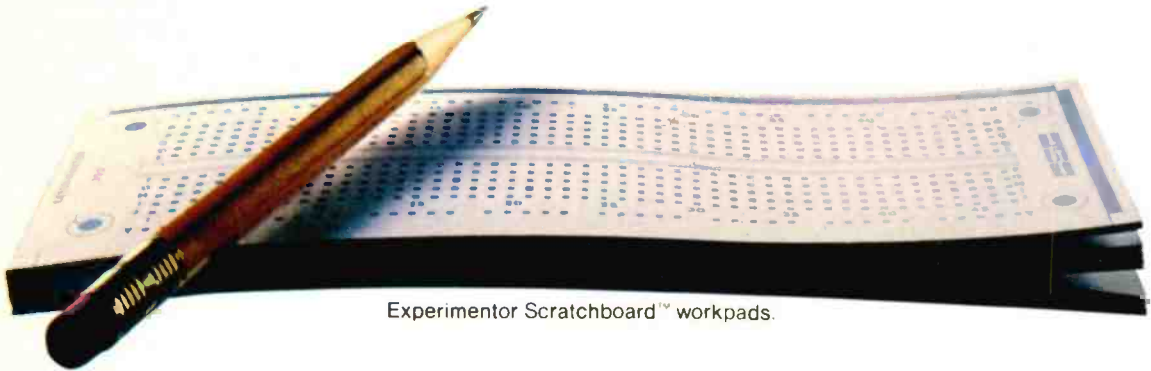

Experimentor Scratchboard™ workpads.



Experimentor Matchboard™ pre-drilled PCBs.

When you have a circuit idea that you want to make happen, we have a system to make it happen quicker'n'slicker'n ever before: The Experimentor System.

You already know how big a help our Experimentor solderless breadboards can be. Now we've taken our good idea one step farther. Twice.

We've added Experimentor Scratchboard workpads, with our breadboard hole-and-connection pattern printed in light blue ink. To let you sketch up a layout you already have working so you can reproduce it later.

With Experimentor Matchboard you can go from breadboard to finished nonstop! We've matched our breadboard pattern again, this time on a printed circuit board, finished and ready to build on. All for about \$2.69*.

There's even a letter-and-number index for each hole, so you can move from breadboard (where they're molded) to Scratchboard™ (where they're printed) to Matchboard™ (where they're silkscreened onto the component side) and always know where you are.

When you want to save time and energy, you can't beat The Experimentor System.

CONTINENTAL SPECIALTIES CORPORATION

70 Fulton Terr. New Haven, CT 06509 (203) 624-3103 TWX 710-465-1227
OTHER OFFICES: San Francisco (415) 421-8872, TWX 910-372-7992
Europe: CSC UK LTD. Phone Saffron-Walden 0799-21682, TLX 817477
Canada: Len Finkler Ltd., Ontario



Call toll-free for details
1-800-243-6077

* Suggested U.S. resale. Available at selected local distributors. Prices, specifications subject to change without notice. © Copyright 1979 Continental Specialties Corporation

CIRCLE 6 ON FREE INFORMATION CARD

The Personal Computer Line by OHIO SCIENTIFIC



C1P: \$349! A dramatic breakthrough in price and performance. Features OSI's ultra-fast BASIC-in-ROM, full graphics display capability, and large library of software on cassette and disk, including entertainment programs, personal finance, small business, and home applications. It's a complete programmable computer system ready to go. Just plug-in a video monitor or TV through an RF converter, and be up and running. 15K total memory including 8K BASIC and 4K RAM — expandable to 8K.

C1P MF: \$995! First floppy disk based computer for under \$1000! Same great features as the C1P plus more memory and instant program and data retrieval. Can be expanded to 32K static RAM and a second mini-floppy. It also supports a printer, modem, real time clock, and AC remote interface, as well as OS-65D V3.0 development disk operating system.

C2-4P: \$598! The professional portable that has over 3-times the display capability of 1P's. Features 32 x 64 character display capability, graphics, full computer type keyboard, audio cassette port, and 4 slot BUS (only two used in base machine). It has 8K BASIC, 4K RAM, and can be expanded to 32K RAM, dual mini-floppies and a printer.

C2-4P MF: \$1599! It's a big personal computing mini-floppy system at a special package price. Contains the famous C2-4P microcomputer with 20K static RAM, 5" mini-floppy unit for instant program and data loading, RS-232 circuitry (for optional modem and printer), and four diskettes featuring exciting games, personal, business and education applications.

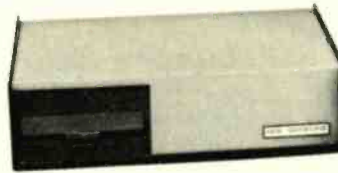

C2-8P: \$799! The personal class computer that can be expanded to a full business system. Has all the features of the C2-4P plus an 8 slot BUS (3-times greater expansion ability than the C2-4P). Can be expanded to 48K RAM, dual floppies, hard disk, printer and business software.

C2-8P DF: \$2599! A full business system available at a personal computer price! The system includes the powerful C2-8P microcomputer (32K RAM expandable to 48K), dual 8" floppy unit (stores 8-times as much information as a mini-floppy), and 3 disks of personal, educational and small business applications software. Has all the capabilities of a personal system including graphics plus the ability to perform Accounting, Information Management, and Word Processing tasks for small business. Contact your local Ohio Scientific dealer

All prices, suggested retail

OHIO SCIENTIFIC

America's largest full-line microcomputer manufacturer
1333 S. CHILLICOTHE RD., AURORA, OHIO 44202 (216) 562-3101

* Monitors and cassette recorders not included. Ohio Scientific offers a combination TV/Monitor (AC-3P) for \$115.

Automotive "brain" astounds the experts, puts both computer and cruise control at your fingertips!

For the first time ever, you can put a true computer in your car, truck or RV which gives you the most effective and functional cruise control ever designed, plus complete trip computing, fuel management system, and a remarkably accurate quartz crystal time system. It is called CompuCruise™.

So simple a child can operate, the new CompuCruise combines latest computer technology with state-of-the-art reliability in a package which will not likely be available on new cars for years to come.

CRUISE CONTROL WITH A MEMORY, UNIQUE SEEK-AND-HOLD CAPABILITY.

CompuCruise remarkable cruise control performs in a totally different manner than any other unit because it is more than a simple speed maintaining device. With CompuCruise, you establish your desired cruising speed even before you reach the highway and activate the system any time by simply pressing a button. CompuCruise then seeks and maintains the desired speed until you override or shut off the system. You resume cruise control again at any time by pressing the same button. CompuCruise, unlike most vacuum-mechanical systems, is fully electronic, more accurate and more reliable than any other unit you can buy.

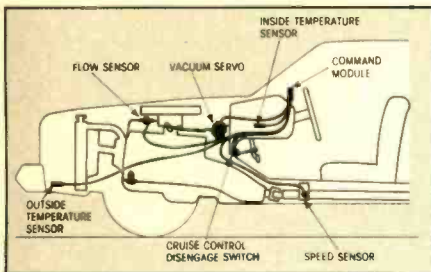

AIRLINE PILOTS COMPARE COMPUCRUISE™ TO SOPHISTICATED AVIONICS EQUIPMENT.

Similar to types of computers used on modern airliners, the CompuCruise slim panel-mounted control module contains a digital readout and back-lighted control buttons, both readily visible in the dark. By quickly learned systems of inquiry, the driver can elicit virtually any informa-



tion relating to time, distance, fuel and performance of his vehicle.

There are a number of digital-type instruments on the market which can be purchased for your car, purporting to provide functional data on performance, but all are basically calculators, operating on fixed information provided by the driver.

CompuCruise is a true computer, operating from automatic data sensors which constantly react to changing conditions, automatically recomputing vital data every second. Each function operates independently, with data displayed and updated constantly until you change your request of the computer.

Fuel management takes on new significance because CompuCruise tells you the most effective driving speeds, the type and brand of gasoline most suitable for your vehicle. It will tell you the effects of different types of tires and different tire pressures, road conditions, and engine tune-up condition. You can get instantaneous computations on current gas mileage, fuel required to arrival, and actual fuel remaining.

Battery condition can be checked regularly, saving you from the potential embarrassment of being stranded without warning.

TYPICAL DATA:

- ✓ Cruise Control
- ✓ Time, E.T., Lap Timer, Alarm
- ✓ Time, Distance, Fuel to Arrival
- ✓ Time, Distance, Fuel to Empty
- ✓ Time, Distance and Fuel on Trip
- ✓ Current or Average MPG, GPH
- ✓ Fuel Used, Distance since Fillup
- ✓ Current and Average Vehicle Speed
- ✓ Inside, Outside or Coolant Temperature
- ✓ Battery Voltage
- ✓ English or Metric Display

COMPUCRUISE™ DIGITAL QUARTZ CRYSTAL TIME SYSTEM IS INCREDIBLE.

CompuCruise digital time system performs four independent time functions encompassing (a) stop watch and lap timer functions, (b) hours, minutes and seconds, (c) alarm or warning function, and (d) trip time indicator. The time system operates full time, whether your vehicle is operating or not. It will even wake you up after a short roadside nap.



YOUR COMPUCRUISE IS SMART! IF YOU PUSH THE WRONG BUTTON IT WILL LET YOU KNOW BY DISPLAYING "ERROR".

COMPUCRUISE™ WORKS ON FOREIGN OR AMERICAN CARS; IS PRICED FOR THE AVERAGE MAN'S BUDGET

You do-it-yourselfers can readily install the unit, but complete and detailed instructions are also included for the automotive service facility. CompuCruise units are fully operable on most foreign or American cars, trucks or RV's. At \$199.95 the unit is only a few dollars more than the cost of cruise control alone on most vehicles, yet offers a whole new world of computerized management functions.

This is an exclusive system, fully warranted for 90 days from installation, delivered to you complete with all required hardware. You need only basic tools for the total job.

When you receive your unit, inspect it completely. If you are not 100% satisfied, return the complete unit before installation and your money will be refunded without question.

TO ORDER YOUR UNIT, complete the coupon below, enclosing \$199.95 (ADD \$5.50 if front-wheel drive). This covers all shipping, insurance and handling costs. Your unit will be shipped within three weeks.

NOTE: Mountable on foreign or domestic vehicles including standard trans. EXCEPT FOR DIESEL OR FUEL INJECTED ENGINES.

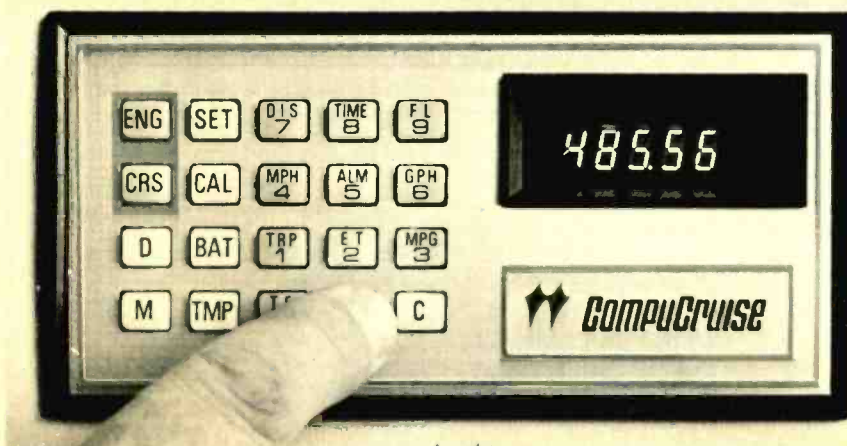

(415) 838-8060

Technically competent personnel available to answer your questions.

COMPUCRUISE

TO: ZEMCO, Inc. (415) 838-8060
12907 Alcosta Blvd.
San Ramon, Ca. 94583

Ship _____ CompuCruise™ units @ \$199.95
Model 44 (WITH CRUISE CONTROL)
 Add \$5.50 for front-drive

Ship _____ CompuCruise™ Units @ \$159.95
Model 41 (WITHOUT CRUISE CONTROL)
 Add \$5.50 for front-drive

Total enclosed: \$ _____
(CA residents add Sales Tax)

Charge to my Master Charge Visa

Card Number _____

Date Expires _____

Signature _____

Make vehicle: _____

Name: _____

Address: _____

City: _____ State & Zip _____

Radio-Electronics®

THE MAGAZINE FOR NEW IDEAS IN ELECTRONICS

Electronics publishers since 1908

MAY 1979 Vol. 50 No. 5

BUILD ONE OF THESE

- 35 **Time/Voltage Calibrator**
Provides the time and voltage references that you must have to calibrate your digital test equipment.
- 40 **Bowling Game**
Electronic game that simulates rolling that ball down the alley. Requires some mechanical construction.
- 59 **Audio Test Station**
Part 4—The voltmeter and digital frequency meters are described.

GENERAL ELECTRONICS

- 4 **Looking Ahead**
Tomorrow's news—today.
- 6 **What's News**
Pictures and briefs of news highlights.
- 44 **What's New in Rechargeable Batteries**
NiCad, Alkaline . . . and now Lithium.
- 86 **Computer Corner**
Direct memory access—What it is and how it's used.
- 94 **State of Solid State**
The mysterious I^2L logic process revealed.

HI-FI STEREO PRO-SOUND

- 47 **Buyers Guide to Hi-Fi Amplifiers**
- 48 **How to Select the Best Amplifier**
- 53 **Front-Panel Controls and Features**
- 55 **Amplifier Specifications Roundup**

RADIO

- 64 **Troubleshooting CB Receivers**
Basic circuits and suitable test equipment.
- 68 **Communications Corner**
New monthly column devoted to developments in CB, SWL, UHF, VHF, and amateur radio.
- 80 **Hobby Corner**
BFO for shortwave receivers helps clarify reception.

TELEVISION

- 98 **Jack Darr's Service Clinic**
Fast recovery diodes and DC power supplies.
- 98 **Service Questions**
R-E's Service Editor solves technician problems.

EQUIPMENT REPORTS

- 24 **Heath H17 Floppy Disc System**
- 26 **Sylvania Module Extension Cable Kits**
- 32 **Microproducts Apple II Assembler/Editor**

DEPARTMENTS

- | | | | |
|-----|-----------------------|-----|-----------------|
| 130 | Advertising Index | 107 | Market Center |
| 14 | Advertising Offices | 78 | New Literature |
| 14 | Editorial | 102 | New Products |
| 131 | Free Information Card | 103 | Stereo Products |
| 16 | Letters | | |

ON THE COVER

A Time/Voltage Calibrator is a must if you have digital test equipment. It's the only way available to most of us to keep our test gear calibrated. Learn how to build your own calibrator. Story starts on page 35.

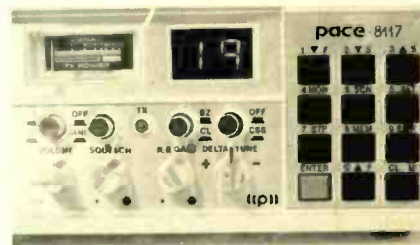

PACE 8117 is a computerized CB transceiver. For more data see our new Communications Corner on page 68.

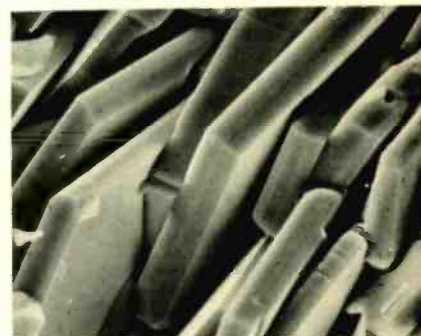

TITANIUM DISULFIDE COMPOUND is used in new Exxon rechargeable lithium battery. Read the whole story starting on page 44.

Radio-Electronics, Published monthly by Gernsback Publications, Inc., 200 Park Avenue South, New York, NY 10003. Phone: 212-777-6400. Controlled Circulation Privileges Pending at Concord, NH. One-year subscription rate: U.S.A. and U.S. possessions, \$9.98, Canada, \$12.98. Other countries, \$14.98. Single copies \$1.25. © 1979 by Gernsback Publications, Inc. All rights reserved. Printed in U.S.A. (ISSN 0033-7862)

Subscription Service: Mail all subscription orders, changes, correspondence and Postmaster Notices of undelivered copies (Form 3579) to Radio-Electronics Subscription Service, Box 2520, Boulder, CO 80322.

A stamped self-addressed envelope must accompany all submitted manuscripts and/or artwork or photographs if their return is desired should they be rejected. We disclaim any responsibility for the loss or damage of manuscripts and/or artwork or photographs while in our possession or otherwise.

As a service to readers, Radio-Electronics publishes available plans or information relating to newsworthy products, techniques and scientific and technological developments. Because of possible variances in the quality and condition of materials and workmanship used by readers, Radio-Electronics disclaims any responsibility for the safe and proper functioning of reader-built projects based upon or from plans or information published in this magazine.

Looking ahead

AM stereo: The battle for stereo on the standard broadcast band is taking some interesting new turns. Although the industry-wide National AM Stereo Radio Committee (NAMSRC) submitted field-test data to the FCC, the Commission seemed dissatisfied and asked for more broadcast testing and more information, with the indication that selection of a system would take longer than expected—if, indeed, the FCC decides to authorize AM stereo broadcasting at all. The second surprise was the choice by the ABC Radio Network of the Kahn-Hazeltine independent sideband (ISB) system as the one it feels “will best serve the interests of the broadcasters and the public.” The ISB system, which carries left-channel information on the left sideband, right-channel on the right sideband, was not one of the systems tested by NAMSRC, although it is the oldest proposed system. ABC is currently testing the system on its New York station.

Teletext: EIA has established a special committee to evaluate various home video data systems and eventually establish standards for their use in the U.S. Several European countries already are using these systems, which present graphic data on home TV screens. Teletext systems display data broadcast during the vertical interval of the television picture. A second basic system, viewdata, is transmitted on telephone lines and provides the home user with access to a wide variety of material. Both systems can provide information on demand—such as weather forecasts, news, sports, stock market reports, highway information, etc., while viewdata eventually can serve as the home display terminal for a central computer.

Projection: Henry Kloss, who as founder and president of Advent Corporation was the father of home color projection television, has re-entered the business with a new projection TV system (he quit Advent in 1976). The “Novabeam” system, scheduled for marketing next fall, is based on a new Kloss-designed tube-and-lens system. Claims made for Novabeam are higher brightness, sharper resolution, lower cost than comparable three-tube two-piece television projectors now on the market.

Electronic gamesmanship: The toy business has discovered electronics with a vengeance, and things will never be quite the same. The major impact currently is in games, where even the familiar Scrabble is available in a handheld electronic version called *Sensor*. Although the first electronic games used the family TV set, toy manufacturers now have discovered they can accomplish many of the same effects without tying up the home video outlet. Many of the new handheld games were inspired by video games and include both visual displays and audio effects. While Mattel is the undisputed pioneer in the handheld game, the game that created the most talk at the recent New York Toy Fair was Milton Bradley’s *Microvision*. This \$50 unit is programmable, like a sophisticated TV game—and it has a screen, a two-inch-square liquid-crystal panel with 16 X 16 resolution. It can be used to play all of the familiar “TV games” plus new ones to come. How big is the pocket

electronic game business? Just ask Mattel. It sold more than 2,000,000 of them last year.

Digital VTR: Television broadcasters are in a bit of a tizzy these days about videotape recorders. The “standard” four-head quad VTR, first introduced by Ampex in 1956, is an expensive two-inch-tape-gobbling monster and current technology has made possible its replacement by a far more economical one-inch helical-scan type of recorder that is superior in virtually every way. So naturally, broadcasters are beginning to replace their big quad recorders with the new standard helical unit—or are they? There’s still a nagging worry that analog recording is obsolete and that digital VTR’s represent the true wave of the future.

This is a real problem for the VTR manufacturers, who want to sell recorders now without encouraging a wait-for-digital attitude but who still want to impress potential customers that they’re up to date on digital technology. Britain’s Independent Broadcasting Authority demonstrated a digital recorder at a recent industry conference, impressing broadcast engineers and putting pressure on VTR leader Ampex. So at a major digital recording seminar sponsored by the Society of Motion Picture and Television Engineers, Ampex felt it was necessary to present something concrete along with its technical papers, without discouraging broadcasters from buying the latest in analog recorders. What Ampex did was take one of its four-head broadcast recorders, modify it for eight heads (and about twice the tape usage) and demonstrate perhaps the best digitally recorded video pictures ever shown. At the same time, it warned broadcasters that a practical, commercial digital recorder was still five to seven years away. It remains to be seen whether broadcasters will buy the new generation of helical-scan analogs or patch up their old quad machines and hold out for the start of the digital age.

Longitudinal scan: The home videocassette recorder business is also faced with a problem in standards and formats, but digital recording doesn’t enter the picture. In the consumer field, the issue may become helical vs. longitudinal scan. Longitudinal recording, of the type used in audio, was attempted for video in the 1950’s and abandoned. Now it promises to make a comeback in portable recorders, thanks to new tape transport systems. BASF is building a factory in California to turn out its multitrack LVR (longitudinal video recorder) which uses 8-mm tape in a portable format. Eastman Kodak, which is actively developing video recorders, is believed to be working on a longitudinal format. Toshiba recently demonstrated a longitudinal-scan system using half-inch tape with 220 video tracks in an endless-loop cartridge. The company gave no indication of when it would produce the unit, if ever, but pointed out it has one-third fewer mechanical parts than the Sony-developed Beta format. The simplicity of longitudinal systems is based on the use of a fixed head instead of the revolving-head system used in helical-scan recorders.

DAVID LACHENBRUCH
CONTRIBUTING EDITOR

How to listen to Moscow, Russia... Moscow, Idaho and your good buddy, Max Moscow.*



RF-2900

Introducing all-band readout in Command Series™ RF-2900 and RF-4900.

Tune in. Sit back. And travel the world with Panasonic's short wave radios—the Command Series. Set your itinerary by simply setting the dial. Get the news from Britain on the BBC. Be in Peking when they announce the new pecking order. Or visit old friends in the old country. Any old country. Even the good ol' U.S.A.

A fluorescent all-band readout in the RF-2900 (shown above) and the deluxe RF-4900 makes it easy to find thousands of overseas and domestic short wave transmissions as well as AM, FM and CB. The Panasonic fluorescent digital display is accurate to within 1 kHz. That's accuracy!

And if you want to hear more, both models give



RF-4900

you more. Like SSB (single sideband) amateur radio. All 40 CB channels. Even Morse communications. And, of course, there's AM and FM.

And like our deluxe short wave receiver, the RF-2900 has an RF-Gain Control to enhance

weak, distant stations or to prevent overload distortion from overstrong stations.

The Command Series from Panasonic. You can travel the world without ever leaving home.

*Short wave reception will vary with antenna, weather conditions, operator's geographic location and other factors. An outside antenna may be required for maximum short wave reception.

Panasonic®
just slightly ahead of our time.

CIRCLE 34 ON FREE INFORMATION CARD

what's news



RCA CELEBRATES ITS 50 MILLIONTH TV SET in 32 years. Here, Jack K. Sauter, RCA marketing vice president, displays on the left the 19-inch *ColorTrak* receiver produced in 1978 and costing \$570. On the right is the first TV set produced by RCA 32 years ago—a 10-inch black-and-white model, which sold in 1946 for \$375.



COMUS C-6 DIET COMPUTER is a micro-processor-based instrument used to determine an individual's proper caloric needs to keep in shape. Keyboard data entry uses the word "SHAPE" (Sex, Height, Age, Pounds and Exercise), to compute the correct daily caloric intake based on metabolism, daily exercise (in 5 code categories) and diet. The unit is handheld, portable and powered by a 9-volt battery; it also doubles as a 4-function calculator with floating decimal (so you can figure out cost-per-serving). The *Comus C-6* comes in an off-white plastic case; it features an 8-digit red LED display and provides 2K bytes of ROM and 128 bytes of RAM. The entire package consists of the computer, instructions, calorie counter and exercise-level table. Selling for a suggested retail price of \$34.95, and it is manufactured by Comus, Inc., 4550 Cascade Rd., Grand Rapids, MI 49506.

DUAL-VISION TV RECEIVER is manufactured by Sharp Electronics, who calls it the "TV of the Future." In the model 17D50, the 17-inch screen can display a 4-inch superimposed black-and-white picture in either the upper or lower corner of the screen, or it can eliminate it entirely. These pictures are also switchable, with the superimposed image becoming the main display and vice versa. The set also contains the following features: electronic varactor tuning; a 17-button/18-function capability; filter; a two-way/two-speaker system; a 75-ohm CATV connector; plus color-adjust, channel-hold and channel-lock controls. The picture tube used is Sharp's *Lynatron Plus High Focus* tube.



LX303

ALL THE MOST WANTED FEATURES AT A MOST WANTED PRICE...

BIG 1/2" HIGH LCD DISPLAY
USE INDOORS OR OUT
200 HOUR 9V BATTERY LIFE
AUTO ZERO, POLARITY,
OVERRANGE INDICATION
100 mV DC F.S. SENSITIVITY
19 RANGES AND FUNCTIONS



Removable cover stores test lead set furnished as part of the unit.



Available accessories include AC adapter, padded vinyl carrying case, 40KV DC probe, 10 Amp DC shunt.



X10 DCV probe adapter available for protecting input up to 10KV.



\$74.95
ONLY
HICKOK

THE HICKOK ELECTRICAL INSTRUMENT CO.
 10514 Dupont Avenue • Cleveland, Ohio 44108
 (216) 541-8060 • TWX: 810-421-8286

Here is the handful of accuracy you've been waiting for. Handsomely encased. Only 12 ounces. Hickok's exciting, new LX 303, 3 1/2 digit Mini-Multimeter with high quality components, one year guarantee and rugged Cyclo-lac® case offers features previously found only in expensive units... at a price under \$75.00! So why wait any longer? The amazing LX 303 is here, NOW! Another American made test equipment breakthrough from Hickok, The Value Innovator. Order today!

CIRCLE 48 ON FREE INFORMATION CARD

See your local Hickok distributor or order below

SPECIFICATIONS:

DC VOLTS (5 RANGES): 0.1mV to 1000V; Accuracy $\pm 0.5\%$ rdg $\pm 0.5\%$ f.s.; Input imped: 10M Ω ; Max. input 1kV except 50CV on 200mV range.

AC VOLTS (40Hz to 5kHz): 0.1V to 600V; Accuracy: $\pm 1.0\%$ rdg $\pm 0.5\%$ f.s. (-2dB max. at 5kHz); Max. input: 600V.

RESISTANCE (6 LOW POWER RANGES): 0.1 Ω to 20M Ω ; Accuracy: $\pm 0.5\%$ rdg $\pm 0.5\%$ f.s. ($\pm 1.5\%$ rdg on 20M Ω range); input protected to 120VAC all ranges.

DC CURRENT (6 RANGES): 0.1mA to 100mA; Accuracy: $\pm 1.0\%$ rdg $\pm 0.5\%$ f.s.

DIMENSIONS AND WEIGHT: 5-7/8" x 3-3/8" x 1-3/4", 12 oz.; **POWER:** 9V batt. (not incl.) or Hickok AC adapter; **READ RATE:** 3/sec. **OPERATING TEMPERATURE:** 0°-50°C.

ADVANCE ELECTRONICS

TO ORDER CALL TOLL FREE
 800-223-0474

54 West 45th Street, New York, NY 10036 212-687-2224



PLEASE SEND ME

_____ Hickok LX303 Digital Multimeters @ 74.95 ea.
 _____ RC-3 AC Adapter, 115VAC (220VAC avail.) @ 7.50 ea.
 _____ CC-3 Deluxe Carrying Case @ 7.50 ea.
 _____ VP-10 10 DCV Probe Adapter @ 14.95 ea.
 _____ CS-1 10A DC Current Shunt @ 14.95 ea.
 _____ VP-40 40 KV DC Probe @ 35.00 ea.

Payment encl. Bill by: Master Charge VISA

Account # _____ Exp. Date _____

Name _____

Address _____

City _____ State _____ Zip _____

Add \$3.00 Postage and Handling, N.Y. residents add sales tax.

Microcomputers are here! Get in on the ground floor with NRI's new "at home" training in computer technology.

Only NRI Gives You "Hands-on" Experience as You Build Your Own
Designed-for-learning Microcomputer

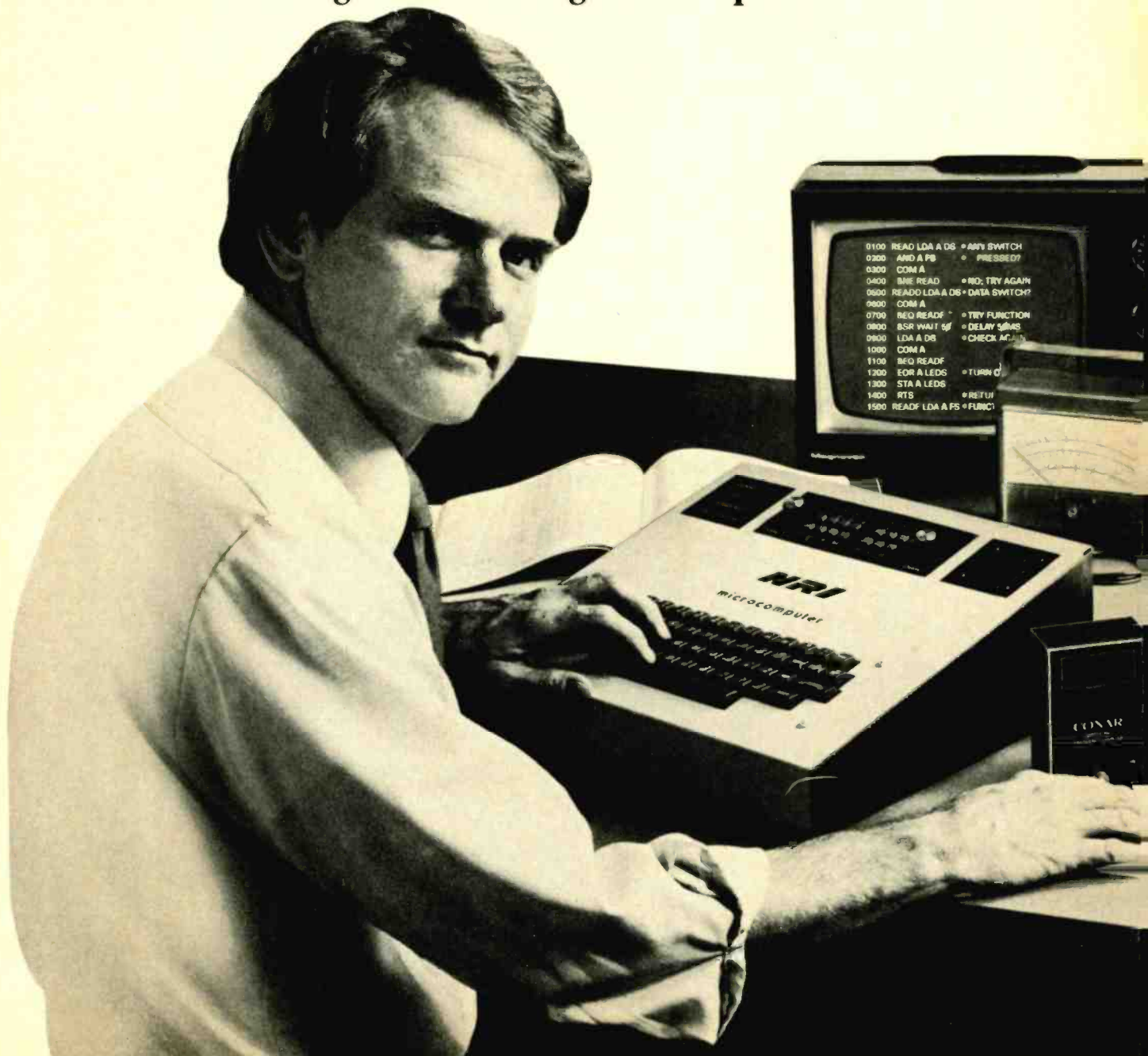

The microprocessor, that amazing little chip which shrinks electronic circuitry to microscopic size, has changed the world of the computer with dramatic speed. Now, big-performance computers are here in compact sizes...priced to make them practical for thousands of medium and small businesses, even homeowners and hobbyists.

Microcomputers are already being put to work on jobs like inventory control, payrolls, cost analysis, billing, and more. In homes, they're able to handle budgets and tax records, control environmental systems, index recipes, even play sophisticated games. And hobbyists across the country are expanding the state of the art while developing their own programs.

**Become a Part of This Incredible World ...
Learn at Home
in Your Spare Time**

NRI can give you the background you need to get into this booming new field. Microcomputers require a new discipline, a broader viewpoint... the ability to think in both hardware and software terms. And NRI's new course in computer technology is geared to bridge the gap.

You get a firm foundation of digital theory while you get practical,



"hands-on" experience working with the NRI Discovery Lab®, assembling test instruments you keep, and even building your own fully functional microcomputer.

Best of all, you do it at your own convenience. You learn at home with clearly written, "bite-size" lessons that carry you through the course in logical progression. There's no need to go to night school or quit your job...you progress at the pace that's most comfortable to you, backed by your personal NRI instructor and individual counseling whenever you want it.

Assemble an Advanced Microcomputer with Exclusive Designed-for-Learning Features

Only NRI trains you with a microcomputer that's specifically designed to teach you important principles as you build it. This state-of-the-art unit performs every function of comparable commercial units, has capabilities well beyond many. But each step of construction provides specific training, reinforces theory to make it come alive. And once you've finished, your microcomputer is ready to go to work for you. Or you can even sell it commercially.

You also assemble professional test instruments for use in your training. You get your own CMOS digital frequency counter and transistorized volt-ohm meter to keep and use in diagnosing problems and servicing computers. Together with up-to-the-minute lessons and NRI's 60-plus years of home study experience, you get the most in training and value.

Other Courses in Today's Electronics

Even the servicing of home entertainment equipment has taken quantum jumps forward. NRI keeps you right up with the latest, with training in stereo, video tape and disc players, and the latest TVs. You even build your own 25" diagonal color TV, the only one complete with built-in digital clock, varactor tuning, and computer control that lets you program an entire evening's entertainment. In our complete communications course, you learn to service two-way radio, microwave transmitters, radar, AM and FM transmitters, CB radio, paging equipment, and more. And you build your own 2-meter transceiver or 40-channel CB while you learn.



Free 100-Page Catalog No Salesman Will Call

Send the postage-paid card today for your personal copy of the NRI electronics course catalog. It shows all the equipment, training kits, and complete lesson plans for these and many other courses. There's no obligation of any kind and no salesman will ever bother you. Find out how you can learn new skills, keep up with technology, advance your future with training for new opportunities. Get in on the ground floor now! If card has been removed, write to:



NRI Schools
McGraw-Hill Continuing
Education Center
3939 Wisconsin Ave.
Washington, D.C. 20016

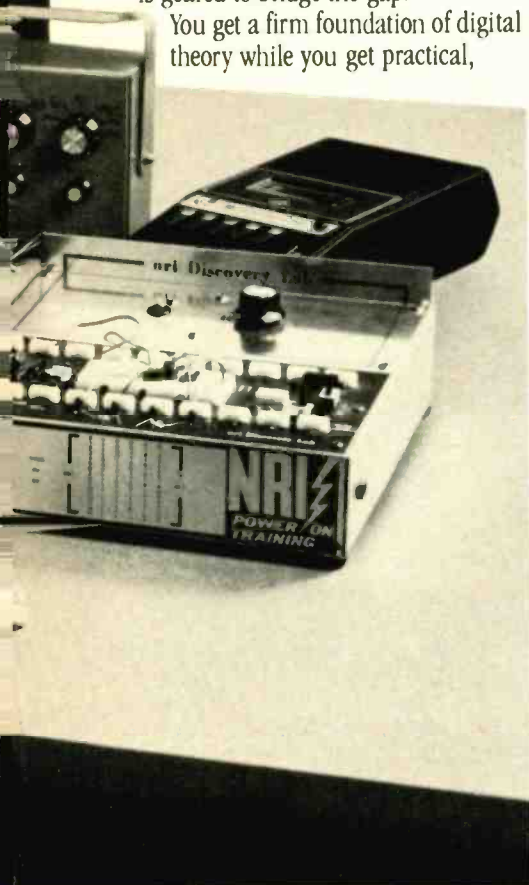



Fingertip control of all microprocessor calculations; data readout in bright LED digits from solid oiled walnut console.

Aerospace-designed transmitter!

Its wind speed and direction instruments are among the most sophisticated available. Rather than relying on friction-causing reed switches or other mechanical devices, they utilize solid-state infra-red sensors, and transmissive optical encoding. It offers unprecedented accuracy and within one-tenth of a mile per hour!

The remote transmitter unit with its windcup and weathervane mounts easily on your TV antenna mast, transmits data to your console through cable supplied.



Remote transmitter mounts on TV antenna mast, transmits data to your console through cable supplied.



THE Electronic Weatherman

New Heathkit Weather Computer

Now...with your own computerized weather station, you can have
 the *temperature* (indoors and out)...*wind speed and direction*
 ...*the wind chill factor* ...*the barometric pressure* ...*the time and date*
 ...*plus much more* ...*right at your fingertips!*

There's nothing else like it available today! A personal weather computer that not only monitors the current weather data, but also computes significant changes and stores wanted data in its memory! So now, for the first time, you'll have all the weather information you need for your personal and business planning!

Unique digital data display

The handsome solid oiled walnut computer console features large, bright, LED numerals, displaying up-to-the-second data on the time (AM, PM or 24 hour format) and date; indoor and outdoor temperatures (in your choice of Fahrenheit or Celsius); wind speed (in miles per hour, kilometers per hour or knots) and direction on a 16-point compass plus barometric pressure in millibars or inches of mercury.

The instrument's on-board microprocessor even calculates the wind chill factor at the touch of a button. It also stacks barometric pressure readings in memory, so it can compute the rate of rise or fall on command! The barometer readings are derived from a newly-developed piezo resistive silicon bridge transducer that senses the most minute changes in pressure. It's the first and only truly digital electronic barometer!

An electronic almanac!

The Weather Computer stores high and low temperatures as well as the time and date at which they were recorded. In addition, it records the highest wind gust speed and time, ready for instant recall. The data is stored in memory until you choose to clear it.

For serious weather research purposes, the instrument can be connected to a chart recorder for hard copy records. And, it can be interfaced with any compatible digital computer for even more sophisticated weather charting and forecasting. As a final thoughtful design touch, the instrument even makes provision for battery back-up to preserve the data stored in memory in case of power failure.

The Electronic Weatherman is a truly unique computerized weather instrument, offering capabilities never before available to the layman with a serious interest in the weather. For business or personal reasons, you'll find it an investment that can pay for itself many times over!

Easy-to-build kit form

If you want the fun (and savings) of building it yourself, you'll find the Heathkit Digital Weather Computer surprisingly easy to build, thanks to the fully-illustrated step-by-step assembly manual. Or, you can order yours assembled, ready to install and use.

The Heath Electronic Weatherman comes complete with remote transmitter unit, 100 feet of connecting cable and a solid oiled walnut console. Order yours now and be prepared for the weather, whatever comes!

**For Fastest Service, Order by Phone
 CALL (616) 982-3411**

HEATH
Schlumberger

HEATH COMPANY
 Dept. 020-534
 Benton Harbor
 Michigan 49022



Gentlemen: Please send me...

- Heathkit Weather Computer Kit(s) (ID-4001) with 100' of cable each (IDA-1290-2) @ \$383.90 plus \$3.95 shipping and handling each.
- Assembled Digital Weather Computer(s) with 100' of cable each (IDW-4001) @ \$595.00 plus \$3.95 shipping and handling each.

I enclose check money order for \$ _____;

or, Please charge to my VISA Master Charge: Code # _____

Acct. # _____ Exp. Date _____

Signature _____
 (Necessary to send merchandise)

Name _____
 (Please Print)

Address _____

City _____ State _____ Zip _____

Prices are mail order and effective through May 15, 1979. GX-360

Communications And You

We all communicate. You're reading this editorial. You talk to people on the telephone, you watch television, you write letters. And we all use equipment to aid us in our communications. This equipment can vary from the pencil to the computer.

The most commonly used communications equipment has electronic circuitry as its heart. It's a CB radio, a UHF/VHF radio, an amateur radio station, an all-wave receiver or a scanner and it is a hot item—an item many Radio-Electronics readers want to be kept up to date on.

Hearing this in your communications to us, we've added a new regular monthly column. It has been titled "Communications Corner." It will appear every month and is intended to be responsive to your needs. While no reader questions about communications will be answered directly, your comments about the column will be carefully considered as future columns are prepared.

I think you'll like it. Turn to page 68 now, and you can judge for yourself.

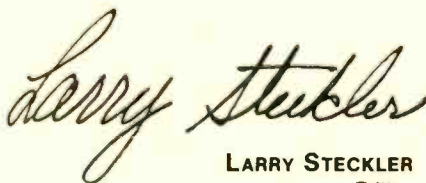
LARRY STECKLER
Editor

Radio-Electronics®

Hugo Gernsback (1884-1967) founder

M. Harvey Gernsback, editor-in-chief and publisher

Larry Steckler, KTX-3644, CET, editor

Arthur Kleiman, KTZ-3288,
managing editor

Robert F. Scott, CET, W2PWG,
KXK-8533, technical editor

Sonia Greenbaum, copy editor

Jack Darr, CET service editor

Leonard Feldman
contributing high-fidelity editor

Karl Savon, semiconductor editor

David Lachenbruch, contributing editor

Earl "Doc" Savage, K4SDS, hobby editor

Ruby Yee, production manager

Robert A. W. Lowndes, production
associate

Marie J. Stolfi, production assistant

Harriet I. Matysko, circulation director

Arline R. Bailey, advertising coordinator

Cover design by Louis G. Rubsamem
Cover photo by Mike Wilson

Radio Electronics is a member of the *Institute of High Fidelity* and is indexed in *Applied Science & Technology Index* and *Readers Guide to Periodical Literature*.

Gernsback Publications, Inc.
200 Park Ave. S., New York, NY 10003
(212) 777-6400

President: M. Harvey Gernsback
Vice President: Larry Steckler
Treasurer: Carol A. Gernsback
Secretary: Bertina Baer

ADVERTISING SALES

Paul McGinnis
Director of Marketing

EAST

Stanley Levitan
Radio-Electronics
200 Park Ave. South
New York, NY 10003
(212) 777-6400

MIDWEST/Texas/Arkansas/Okla.

Ralph Bergen
The Ralph Bergen Co.
540 Frontage Road—Suite 361-A
Northfield, Illinois 60093
(312) 446-1444

PACIFIC COAST Mountain States

Jay Eisenberg
J.E. Publishers Representative Co.,
8732 Sunset Blvd.,
4th Floor,
Los Angeles, CA 90069
(213) 659-3810
Sales Mart Building
1485 Bayshore Blvd., Box 140
San Francisco, CA 94124
(415) 467-0125



**“General Electric
is your most complete source
for general line and industrial
electronic components.”**

Your reputation is our reputation
Tube Products Department • Owensboro, Kentucky 42301

GENERAL  ELECTRIC

letters

T-100 THERMOMETERS

Optoelectronics, Inc., has now assembled a number of T-10Q thermometers and is satisfied with their performance, especially their accuracy. The linearity from 0°C to 100°C is typically .1° or .2°.

ROTATE
WHILE EPOXY
IS SETTING

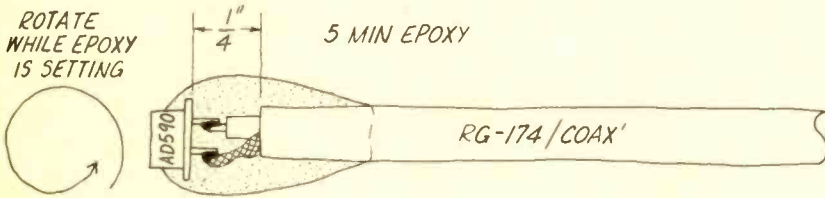

The company has decided to incorporate a change that will be included in all kits. It is recommended that a second 9-volt battery be added in series to boost the supply voltage to 18. This will insure that at least 4 volts is always across the sensor so that high Fahrenheit readings (> 150°F) can be produced. Battery life will be more than

doubled because each battery can discharge down to 5 volts rather than the single battery discharging to 7½ volts. Battery life will be typically greater than 100 hours with carbon-zinc cells, and 300 to 400 hours with alkaline cells. A second

the kits that are shipped.
BILL OWEN
Optoelectronics, Inc.
Fort Lauderdale, FL

WHERE ARE THE DESIGNERS?

Before semiconductors, was the only true designer the one who designed new vacuum tubes?

As some philosophers point out, we seem to have gotten confused over the extent of design versus the intent of design. The intent hasn't changed, but advancing technology has allowed brand-new "extents" especially suitable to reliance on interchangeable parts available in mass quantity at super-low cost. The designer still designs, but he's charged with operating at a different level that today's tools and components make possible. This means that the economies of when to customize—always an expensive proposition—have changed, too, and the good designer adapts to that also, because it

continued on page 22



Full Features
... Yet Portable

\$795
includes
probes

Say "Hello" to an excitingly new 15 lb., 15 MHz 'scope. Smart looking and really convenient — only 5¼" high yet features a large, bright 10cm x 8cm rectangular CRT.

Check this capability: Versatile triggering in excess of 25MHz, 2mV sensitivity, differential mode, and much more. Quality? You Bet! Backed by Exclusive Gould 2-yr. warranty.

It's a winner! Call us for the full story on the OS255.

For free brochure call:
TOLL FREE NUMBER
(800) 325-6400
In Missouri (800) 342-6600

Gould Inc., Instruments Division
3631 Perkins Ave., Cleveland, OH 44114



CIRCLE 12 ON FREE INFORMATION CARD



YESTERDAY



TODAY

AND TOMORROW

THE AMERICAN LEGION
IN ITS 60th ANNIVERSARY YEAR

TRI-COLOR

WIRE CUTTING AND STRIPPING DISPENSER



- 3 Rolls of wire in one convenient dispenser
- 3 Colors, Blue/White/Red, 50 ft. (15m) of each color
- AWG 30 (0.25mm) KYNAR® insulated wire
- Built-in cutting plunger cuts wire to desired length
- Built-in stripper strips 1" of insulation
- Easily refillable
- For wire-wrapping and other applications.

Model No. **WD-30-TRI**
Patent Pending

WD-30-TRI	DISPENSER WITH WIRE	\$5.95
R-30-TRI	TRI-COLOR REPLACEMENT SPOOLS	\$3.95

Kynar® Pennwalt

MINIMUM BILLING \$25.00 / ADD SHIPPING CHARGE \$1.00 / NEW YORK STATE RESIDENT ADD APPLICABLE TAX



MACHINE & TOOL CORPORATION 3455 CONNER ST. BRONX, N.Y. 10475 (212) 994-8600/Telex 125093

CIRCLE 42 ON FREE INFORMATION CARD

You gotta shop around.

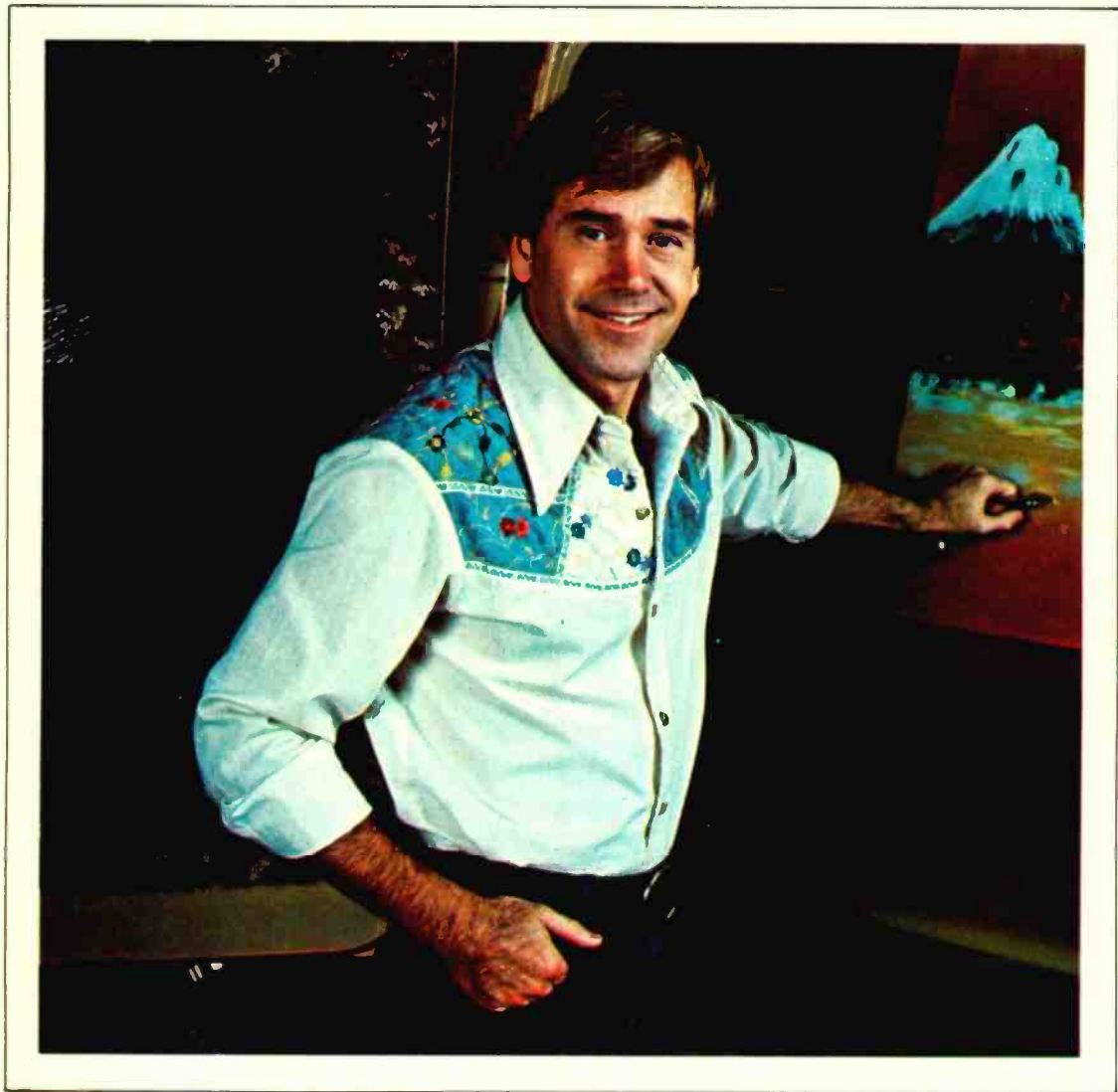

**When you do, you'll probably pick CIE.
You can't afford to settle for
less when it comes to something like
electronics training that could
affect your whole life.**

When you shop around for tires, you look for a bargain. After all, if it's the same brand, better price—why not save money?

Education's different. There's no such thing as "same brand." No two schools are alike. And, once you've made your choice, the training you get stays with you for the rest of your life.

So, shop around for your training. Not for the bargain. For the best. Thorough, professional training to help give you pride and confidence.

* * *

If you talked to some of our graduates, chances are you'd find a lot of them shopped around for their training. They pretty much knew what was available. And they picked CIE as number one.

Why you should shop around yourself.

We hope you'll shop around. Because, frankly, CIE isn't for everyone.

There are other options for the hobbyist. If you're the ambitious type—with serious career goals in electronics—take a close look at what we've planned for you at CIE.

What you should look for first.

Part of what makes electronics so interesting is it's based on scientific discoveries—on ideas! So the first thing to look for is a program that starts with ideas and builds on them!

That's what happens with CIE's Auto-Programmed® Lessons. Each lesson takes one or two principles and helps you master them—before you start using them!

How practical is the training?

This is the next big important question. After all, your career will be built on what you can do—and on how well you do it.

Here are ways some of CIE's troubleshooting programs help you get your "hands-on" training...

With CIE's Experimental Electronics Laboratory...



you learn and review the basics—perform dozens of experiments. Plus, you use a 3-in-1 precision Multimeter to learn testing, checking, analyzing!



When you build your own 5 MHz Triggered-Sweep, Solid-State Oscilloscope you take your first real professional step. You use it as a doctor uses an X-ray machine—to "read" waveform patterns... lock them in... study, understand and interpret them!

When you get your Zenith 19-inch Diagonal Solid-State Color TV you



Pattern simulated.

apply your new skills to some real on-the-job-type troubleshooting! You learn to trace signal flow... locate malfunctions... restore perfect operating standards—just as with any sophisticated electronics equipment!



When you work with a completely Solid-State Color Bar Generator—actually a TV signal transmitter—you study up to ten different patterns on your TV screen... explore digital logic circuits... observe the action of a crystal-controlled oscillator!

Of course, CIE offers a more advanced training program, too. But the main point is

simply this:

All this training takes effort. But you'll enjoy it. And it's a real plus for a troubleshooting career!

Do you prepare for your FCC License?

Avoid regrets later. Check this out before you enroll in any program.

For some troubleshooting jobs, you must have your FCC License. For others, employers often consider it a mark in your favor. Either way, it's government-certified proof of specific knowledge and skills!

More than half of CIE's courses prepare you for the government-administered FCC License exam. In continuing surveys, nearly 4 out of 5 CIE graduates who take the exam get their Licenses!

Shop around...but send for CIE's free school catalog first!

Mail the card. If it's gone, cut out and mail the coupon. If you prefer to write, mention the name and date of this magazine. We'll send you a copy of CIE's FREE school catalog—plus a complete package of independent home study information! For your convenience, we'll try to have a representative contact you to answer your questions. Mail the card or coupon—or write: CIE, 1776 East 17th St., Cleveland, OH 44114.

CIE Cleveland Institute of Electronics, Inc.
 1776 East 17th Street, Cleveland, Ohio 44114
Accredited Member National Home Study Council

YES... I'm shopping around for the **right** kind of career training in electronics troubleshooting—and CIE sounds well worth looking into. Please send me my FREE CIE school catalog—including details about troubleshooting courses—plus my FREE package of home study information! RE-63

Print Name _____

Address _____ Apt. _____

City _____

State _____ Zip _____

Age _____ Phone _____ (area code)

Check box for G. I. Bill information:
 Veteran Active Duty

Mail today!

LETTERS

continued from page 16

affords a whole new set of opportunities.

A related issue, and maybe not one you're concerned about, is that designers needn't be so skilled as in the past. That's true for the same products, and that's progress of a sort. But the super-designers are still there—in as limited quantity as ever—although they're working on difficult problems that couldn't even be approached with the old technology and not on matters that technology made easy to

cope with. That's *important* progress because it means that the pyramid of achievement and knowledge by which we tend to view civilized development is moving up another layer as far as technology is concerned.

Finally, I would like to mention that the feature article in the June 1978 issue was about a product designed with integrated components and that had sufficient design novelty to be awarded a U.S. patent!
DENNIS E. HAMILTON
Penfield, NY

If everyone uses the IC's, who's left to

design them! Does this mean that the future of the electronics industry is at the mercy of the IC designer? Does this mean that if I need only one of something I may not be able to build it? Plain and simple—is all future electronic design going to become dependent on a handful of engineers working for IC manufacturers?—Editor

TV ADAPTER CORRECTIONS

I must make some corrections to my letter which appeared in the August 1978 issue of *Radio-Electronics* (page 16) regarding the TV-to-stereo adapter.

In paragraph 3 regarding the sound detector takeoff in solid-state sets, a sentence reads, "the volume control immediately follows the sound detector in most cases. This, in turn, varies the gain of an amplifier stage. If so, audio does not appear on the volume control." This should read: "The volume control follows the sound detector in most cases, but in some sets, the volume control merely varies a DC voltage, which, in turn, varies the gain of an amplifier stage. In these cases, audio does not appear on the volume control, and must be found elsewhere."

I might add that most American-made sets using this DC volume control system use an IC for the sound detector/IF/audio amplifier functions; and pin 8 of this IC is the best place to pick off the audio. However, this may not always be the case, so to be sure, check with a scope or a signal tracer. Also, since the pin 8 output has about 5 to 6 VDC on it, make sure to use a blocking capacitor.

My apologies to the TV networks regarding my comments on their narrowband telephone lines. Both my letters (in May and August 1978 issues) were written in late December, 1977, before the AT&T switchover to multiplexed video-audio transmission links.

MICHAEL KILEY
Palos Heights, IL

NEW FROM LEADER

The 30MHz Dual Trace Scope with Delay Line.

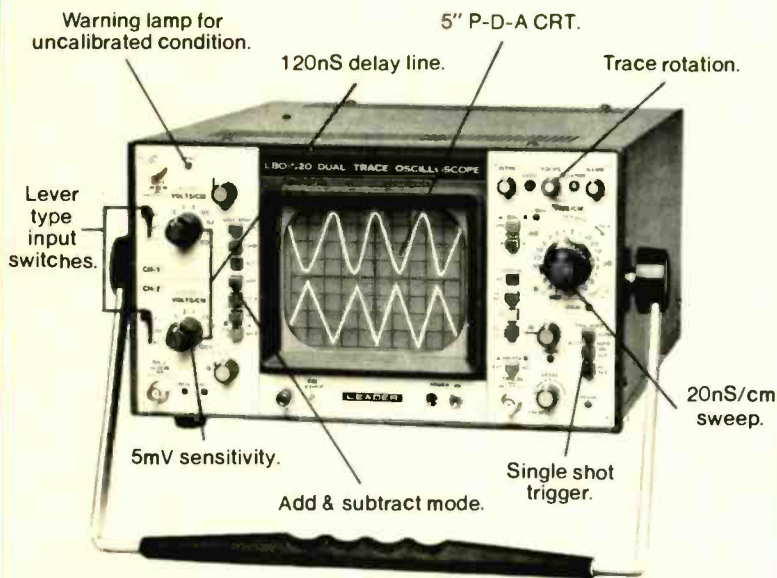

High Sensitivity. P-D-A CRT. Single Shot Trigger.

Model LBO-520 . . . \$ 1050. with accessories

Send For Complete Catalog

All Leader Instruments Are Backed By A **Two Year Warranty!**

When Quality Counts . . .

LEADER
Instruments Corp.

151 Dupont Street, Plainview, N.Y. 11803

Regional Offices Chicago & Los Angeles

East Coast (516) 822-9300 West Coast (213) 882-4335

Call Toll Free: (800) 645-7120 For the Name of Your Nearest Distributor

The good neighbor is you.

Belong.



1101-546 p.—How to Design & Build Your Own TV Games (\$14.95)



1035-434 p.—Instrumentation & Control Systems Engineering Handbook (\$19.95)

An Extraordinary Offer to introduce you to the benefits of Membership in

ELECTRONICS BOOK CLUB

take any **6** of these 24 unique electronics books **\$1.99** for **ALL SIX** (values to \$95.70) for only

with a Trial Membership in the Book Club that guarantees to save you 25% to 75% on a wide selection of electronics books



Facts About Club Membership

- The 6 introductory books of your choice carry publisher's retail prices of up to \$95.70. They are yours for only \$1.99 for all 6 (plus postage/handling) with your Trial Membership.
- You will receive the Club News, describing the current Selection, Alternates, and other books, every 4 weeks (13x a year).
- If you want the Selection, do nothing; it will be sent to you automatically. If you do not wish to receive the Selection, or if you want to order one of the many Alternates offered, you simply give instructions on the reply form (and in the envelope) provided, and return it to us by the date specified. This date allows you at least 10 days in which to return the form. If, because of late mail delivery, you do not have 10 days to make a decision and so receive an unwanted Selection, you may return it at Club expense.
- To complete your Trial Membership, you need buy only four additional monthly Selections or Alternates during the next 12 months. You may cancel your Membership any time after you purchase these four books.
- All books—including the Introductory Offer—are fully returnable after 10 days if you're not completely satisfied.
- All books are offered at low Member prices, plus a small postage and handling charge.
- Continuing Bonus: If you continue after this Trial Membership, you will earn a Dividend Certificate for every book you purchase. Three Certificates plus payment of the nominal sum of \$1.99 will entitle you to a valuable Book Dividend of your choice which you may choose from a list provided Members.

May we send you your choice of 6 of these practical time-and-money-saving books as part of an unusual offer of a Trial Membership in Electronics Book Club?

Here are quality hardbound volumes, each especially designed to help you increase your know-how, earning power, and enjoyment of electronics. Whatever your interest in electronics, you'll find Electronics Book Club offers practical, quality books that you can put to immediate use and benefit.

This extraordinary offer is intended to prove to you through your own experience, that these very real advantages can be yours...that it is possible to keep up with the literature published in your areas of interest, and to save substantially while so doing. As part of your Trial Membership, you need purchase as few as four books during the coming 12 months. You would probably buy at least this many anyway, without the substantial savings offered through Club Membership.

To start your Membership on these attractive terms, simply fill out and mail the coupon today. You will receive the 6 books of your choice for 10-day inspection. YOU NEED SEND NO MONEY. If you're not delighted, return the books within 10 days and your Trial Membership will be cancelled without cost or obligation.

ELECTRONICS BOOK CLUB, Blue Ridge Summit, Pa. 17214

ELECTRONICS BOOK CLUB

Blue Ridge Summit, Pa. 17214

Please open my Trial Membership in ELECTRONICS BOOK CLUB and send me the 6 books circled below. I understand the cost of the books I have selected is only \$1.99 for all 6, plus a small shipping charge. If not delighted, I may return the books within 10 days and owe nothing, and have my Trial Membership cancelled. I agree to purchase at least four additional books during the next 12 months after which I may cancel my membership at any time.

101 295 300 582 806 931 966 1015
1034 1035 1064 1071 1073 1076 1079 1082
1088 1095 1097 1101 1108 1113 1111 1135

Name _____ Phone _____

Address _____

City _____

State _____ Zip _____

(Valid for new Members only. Foreign and Canada add 10%.) RE-59

CIRCLE 30 ON FREE INFORMATION CARD

equipment reports

Heath Model H17 Floppy-Disc System



CIRCLE 50 ON FREE INFORMATION CARD

OWNERS OF HEATH'S MODEL H8 COMPUTER CAN now increase the versatility of their system with Heath's new model H17 floppy-disc system. A floppy-disc system provides a quick method of program storage and retrieval. The advantages over a cassette system include loading and storage of programs in seconds rather than minutes, deleting and updating program and data files, cataloging of files, and more.

The Heath Company's Dept. 570-070, Benton Harbor, MI 49022) H17 floppy-disc system consists of a factory-assembled control board that plugs into the H8 bus and is connected via a ribbon cable to a Wangco model 82 5 1/4-inch drive. The drive is housed in a cabinet that contains a power supply capable of powering a second drive. The cabinet also contains a cutout for an optional second drive.

Each 5 1/4-inch hard-sectored disc is divided into 40 tracks, and each track is subdivided into 10 sectors for a total storage capacity of 102,400 bytes-per-disc. The model 82 drives have a 30-ms track-to-track step-time specification, although some drives will operate much faster. Both drive units in my system operate reliably at a track-to-track step time of 8 ms. As Heath carefully points out, the track-to-track step time is not the same as the random-sector access time, which is the actual time required for the read/write head of the drive to get to a sector once it is requested. A track-to-track step time of 8 ms translates into an average track-to-track step time of 104 ms. Since the disc rotates (at 300 rpm), there is an

additional average time of 100 ms for the sector to come under the read/write head. So, the average random-sector access time is 204 ms. Once a sector on the disc is accessed, data is transferred between the drive and the controller board one bit at a time at a serial rate of 16,000 bits-per-second. To reference this speed, the H17 will load Extended Benton Harbor BASIC in about 2 seconds. Heath's standard 1200 baud cassette interface requires about 2 minutes.

Software

Software is required for a floppy-disc system to function. This software is called an operating system, and Heath supplies its own brand called HDOS. The operating system handles such functions as controlling the drive motor, positioning the read/write head, locating specific data on the surface of the floppy disc, creating files, transferring data, etc. It also provides communication with the user via command instructions.

After initially applying power to the system, HDOS must be "booted." Booting is the process of loading only those segments of HDOS that will enable the system to function. For example, one such portion, called the monitor, decodes the various commands and transfers control to the appropriate software segment to carry out the command. After the command is executed control returns to the monitor. Various other segments of HDOS are loaded into the H8 when necessary.

When HDOS is booted, the monitor program is automatically located in the upper address space of the H8 memory and occupies 2.4K. The other segments of HDOS are located in the lower address space of memory and occupy approximately 9K. Therefore, HDOS requires a total of approximately 12K RAM to operate. If you plan on using a BASIC interpreter, then you will need additional memory to support the BASIC, plus whatever "user" memory you require for your programs.

To boot HDOS, simply set the H8 program counter to 030 000 using the octal keypad on the H8 front panel and execute GO. HDOS will respond by printing ACTION? (BOOT) on the CRT terminal. To boot HDOS, simply type B on the terminal keyboard. After HDOS is loaded it will respond by identifying itself. It will then ask for the current date by printing DATE (DD-MM-YY)? After entering the current date and hitting the carriage return, HDOS is up and running. From now on, HDOS responds with a prompt character to indicate that it is ready to accept commands. There is a wide variety of commands available with HDOS. Among these commands is SYSGEN, which permits you to copy the minimal operating system onto a blank disc. You can use the COPY TO-FROM command to copy additional programs to this disc and store the origi-

continued on page 26

This is easy- anyone can solder- WITH KESTER SOLDER

KESTER
SOLDER

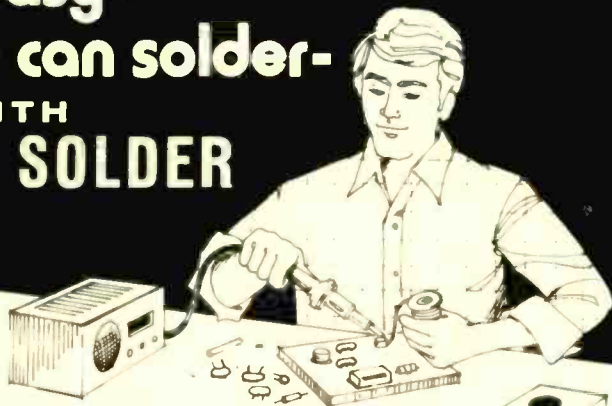

Handymen! Hobbyists! DO-IT-YOURSELFERS!

Let Kester Solder aid you in your home repairs or hobbies. For that household item that needs repairing — a radio, TV, model train, jewelry, appliances, minor electrical repairs, plumbing, etc. — Save money — repair it yourself. Soldering with Kester is a simple, inexpensive way to permanently join two metals.

When you Solder go "First Class" — use Kester Solder.

For valuable soldering information send self-addressed stamped envelope to Kester for a FREE Copy of "Soldering Simplified".



KESTER SOLDER

Litton 4201 WRIGHTWOOD AVENUE/CHICAGO, ILLINOIS 60639

CIRCLE 15 ON FREE INFORMATION CARD

How to be 16 places at once, logically.

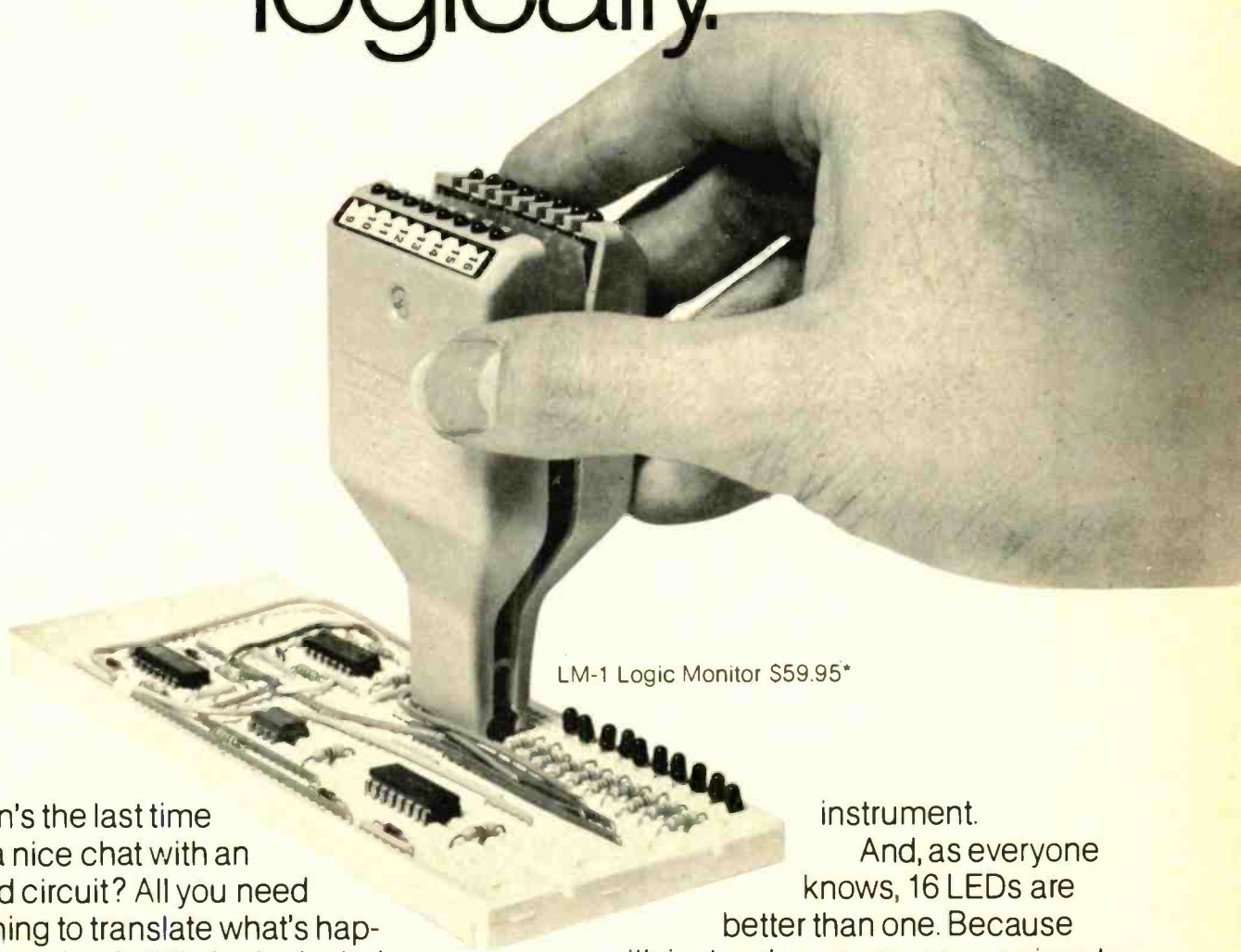

LM-1 Logic Monitor \$59.95*

When's the last time you had a nice chat with an integrated circuit? All you need is something to translate what's happening in its simple little logical mind. Something like our popular Logic Monitors.

Clip one onto an IC — any DIP up to 16 pins — and the 16 LEDs atop our Logic Monitor flash to the rhythm of the state of each pin. You have, in effect, 16 tiny logic probes in one pocket-size circuit-powered

instrument.

And, as everyone knows, 16 LEDs are better than one. Because with just a glance, you can see inputs affecting outputs, a whole IC at a time.

You can watch counters count, decoders decode, logic think its way through. And the more you watch it, the more it tells you. You'll call it smart, a timesaver. We just think it's logical.

CONTINENTAL SPECIALTIES CORPORATION

70 Fulton Terr., New Haven, CT 06509 (203) 624-3103, TWX 710-465-1227
OTHER OFFICES: San Francisco: (415) 421-8872, TWX 910-372-7992
Europe: CSC UK LTD. Phone Saffron-Walden 0799-21682, Telex 817477
Canada: Len Finkler Ltd., Ontario



Call toll-free for details
1-800-243-6077

* Suggested U.S. resale. Available at selected local distributors. Prices, specifications subject to change without notice. © Copyright 1979 Continental Specialties Corporation

CIRCLE 36 ON FREE INFORMATION CARD

EQUIPMENT REPORTS
continued from page 24

nal disc away for safekeeping. A PIP command (Peripheral Interchange Program) is included and is used to copy a file from one disc drive or peripheral device to another. Other commands include SYSHELP, which lists all the valid system commands; DELETE, which erases specific files from the disc; RENAME, which changes the name of a specified file; CAT, which lists the files contained on the disc; and other commands.

Among the many commands and features of HDOS, one in particular struck me as being interesting and unusual. This is a diagnostic routine called TEST 17. After executing this command, you can check the rotational speed of the disc drives. The normalized drive speed is displayed on the LED's on the front panel of the H8 as a decimal number, which should be as close to 1.000 as possible. Since the rotational speed tolerance is 1 percent, any number between 0.990 and 1.010 is acceptable. If it is out-of-tolerance, it can be trimmed by adjusting a pot on the drive assembly itself. Another test that can be performed under TEST 17 is a general checkout. Under this test, a specific bit pattern will be recorded on each sector of the disc and then read back. This test is automatically performed three times, and is intended to check the read/write head and the track seek mechanism. There is also a media check that locates all the bad sectors on the disc (if there are any) and a routine for minimizing the track seek time of the drive being tested.

Other commands are also available that are associated with the operation of the disc

system. For example, if you have various BASIC programs already stored on cassette tape, you can use BASCON to convert these programs into files that can be stored on the disc. If you have text files stored on cassette tape, you can use TXTCON in a similar manner to convert these into disc files. A ONECOPY command is included that allows you to copy files from one disc to another in a system that has only one drive. In addition to HDOS, the software disc also contains BASIC, BUG-8, HASL-8 and TED-8.

Overall, HDOS is a versatile operating system. The H17 disc system which sells for (\$695.00 including software) will greatly increase the versatility of your H8 system. **R-E**

Sylvania Module Extension Cable Kits

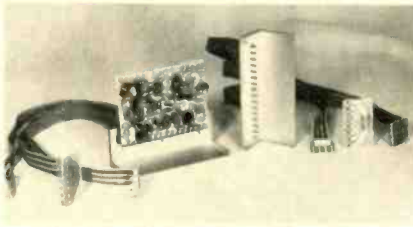

CIRCLE 141 ON FREE INFORMATION CARD

MANY YEARS AGO, WHEN SETS AND CIRCUITS (and I) were much simpler, I used extension cables a good deal. These cables let me get the chassis out onto the bench where I could actually get at it. When I started troubleshooting my first modular TV set, I thought it would be great if we had a set of extension cables so that

we could get each module out where we could get at it . . . since many of us repair such modules, especially larger ones.

Evidently, someone was listening! Sylvania has come up with module-extension cable sets; one of these fits Zenith modules, the other, RCA modules. The Zenith cable set is called the TV Module Extension Kit P/N KZ-2. It will fit 19 Zenith chassis, including the 17EC45, 19EC45, 23EC45, and several others. This set consists of six cables and two special brackets (plus pins) and can be used with 10 different Zenith modules.

The instructions state: "Each Zenith module listed has an even number of pins (8, 12 or 16) on one end and an odd number (7, 11 or 15) on the other. Each bracket has two four-conductor cables and a larger one. One with 7 conductors, the other with 8. By selecting the right cables and plugs, any of these modules can be hooked up correctly." A complete instruction sheet comes with each set, listing the modules and chassis with which it can be used. A special data sheet is also included showing the Sylvania ECG part number semiconductor for the original component used in each module.

The RCA extension cable set is the TV Module Extension Kit P/N KRX-5, with five separate cables for use with the RCA Accu-Color chassis from the model CTC-41 through the model CTC76. Three of the cables have six contacts each, and the two remaining cables have 12 contacts. By choosing the right combination of contacts, any of the 15 modules listed in these chassis can be hooked up. Full hookup data and instructions are provided, as well as a list of ECG replacement semiconductors.

Both extension cable sets use flat multicon-
continued on page 32

**Accuracy like a VTVM...
Convenience like a VOM...**

**NEW BATTERY-OPERATED FET
SOLID-STATE VOLT-OHMMETER #116**

Easy-to-build KIT

\$44.78 =116K

Factory-Wired & Tested

\$60.05 =116W

Now you can get all the benefits of a VTVM (laboratory accuracy, stability and wide range) but with its drawbacks gone: no plugging into an AC outlet, no waiting for warm-up, no bulkiness. New Field Effect Transistor (FET) design makes possible low loading, instant-on battery-operation and small size. Excellent for both bench and field work.

Compare these valuable features:

- High Impedance low loading: 11 meg-ohms input on DC, 1 megohm on AC
- 500-times more sensitive than a standard 20,000 ohms-per-volt VOM
- Wide-range versatility: 4 P-P AC voltage ranges: 0-3.3, 33, 330, 1200V; 4 RMS AC voltage ranges: 1-1.2, 12, 120, 1200V; 4 DC voltage ranges: 1-1.2, 12, 120, 1200V; 4 Resistance ranges: 1-K, 0-100K, 0-10 meg., 0-1000 meg.; 4 DB ranges: -24 to +56DB.

Sensitive easy-to-read 4 1/2" 200 micro-amp meter. Zero center position available. Comprises FET transistor, 4 silicon transistors, 2 diodes. Meter and transistors protected against burnout. Etched panel for durability. High-impact bakelite case with handle useable as instrument stand. Kit has simplified step-by-step assembly instructions. Both kit and factory-wired versions shipped complete with batteries and test leads. 5 1/4" H x 6 3/4" W x 2 7/8" D. 3 lbs.



Send FREE catalog of complete EMC line and name of nearest distributor. RE-5

Name _____
Address _____
City _____
State _____ Zip _____

EMC

ELECTRONIC MEASUREMENTS CORP.
625 Broadway, New York, N.Y. 10012

Come to Tucson, Arizona and to the 1979

**National Electronics Service
Convention of NESDA & ISCET
AUGUST 13-18, 1979**

and to the all-day
ELECTRONICS ROUNDUP

the ONLY national trade show devoted to the electronics service industry

PLUS

- Technical seminars: "Coping With the New Technology"
- Business Management School: "Meeting the Challenge of Change"
- Forums: "Manufacturing and Service - Where Do We Go From Here?"
- Industry problem-solving at the expanded "National Service Conference" and • Golf Tourney • Association Business • Elections • Technician, dealer and association awards • Speakers from Gov't. and Industry • Hospitality/Social affairs • Trips to Mexico and Old Tucson • 11 scheduled meals

ALL EVENTS INCLUDED IN ONE LOW REGISTRATION FEE

\$90 per initial registration; \$60 per each add'l family adult

REGISTER PRIOR TO JUNE 30 AND SAVE 10%

Special children's registration (for children's functions only) \$25

MAIL TO

1979 National Electronics Service Convention
1715 Expo Lane, Indianapolis, IN 46224 (Ph. 317-271-8160)

Name _____ Amt. \$ _____
Address _____
City _____ State _____ Zip _____



Take a good look at VACO.



THE SUPER CASE
70260

The world famous Super Case. Complete with 48 of the most popular and professional problem-solving tools. From screwdrivers and nutdrivers to pliers, wrenches, crimping tools and more. A super variety and super value. All unconditionally warranted from Vaco, of course. The Super Case and all the other fine Vaco tools can be seen in our new 1979 catalog. It's free, just write. Say you want to take a good look at VACO.

Vaco Products Company, 1510 Skokie Blvd.,
Northbrook, IL 60062 U.S.A.

VACO[®]

CIRCLE 46 ON FREE INFORMATION CARD

See The Newest In Quality Electronics You



Custom Car Accessories like the Heathkit GC-1406 Digital Quartz Car Clock shown, or it's companion car clock with trip timer and stopwatch functions for the rally enthusiast, are easy and fun to build. And you have the quality and dependability in custom car accessories you can show-off with pride. Now you can choose one of these fine car clocks, a windshield wiper delay, a deluxe mobile siren and P.A. system, an ultra-sonic intrusion alarm, an electronic speed control or a cab-to-camper intercomm — all in money-saving kit form you can build, service and install yourself.

A Super-Accurate Digital Alarm. The ideal choice for a 'first kit' — with snooze feature, AM and PM indicator, 12 or 24 hr. format and pleasant green-blue digital display. Budget priced, too!



A Doorbell That Plays Your Favorite Tune! A fun way to greet guests with any 16-note tune you program — and you can even add remote speakers!



Low-Cost Home Security with this Heathkit GD-600 Photoelectric Lamp Switch. Turns your lamp on at dusk — off at daylight, for that 'lived-in' look when you're away from home.

Super Coinshooter! The GD-1190 is Heath's finest metal locator with adjustable discrimination and push-button tuning that rejects junk and finds coins.



For Treasure Hunters! The Heathkit GD-348 finds buried metal objects with it's sophisticated "induction-balance" system. The tone from the built-in speaker grows louder as you pinpoint your find — or you can use the front panel meter or optional headphones.

Learn To Service and Maintain Your Car's Electrical System with this newest Heathkit Automotive Electrical Continuing Education Program. Think of the money you'll save when you really understand how your car's electrical system works and how you can service it. This 4-part self-learning program takes you through electrical principles, starting and charging systems and accessories and body electrical...all at your own pace and at lowest cost.

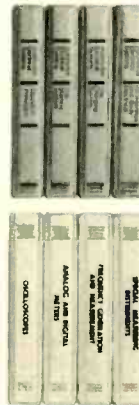

Learn How To Use Electronic Test Instruments with this new Heathkit self-learning program. A progressive 4-part program using Heath's famous programmed instruction with audio and visual aids for maximum efficiency. Learn to use electronic meters, oscilloscopes, frequency generators and special measuring instruments.

Radio Control Gear You Can Depend On! From the leader in R/C development. See this new 8-channel, open gimbal transmitter with Heath's instant plug-in frequency change feature...all Heath firsts!...plus sensational savings on complete systems and R/C Starter Sets.



Build Your Own Custom Stereo And Get Heath Quality Plus System Savings! Choose from Heath's complete line of quality audio products for the kind of custom sound reproduction you want...from the newest and finest professional rack-mounted components to a full range of super-value components including: receivers, tuners, amplifiers, pre-amps., custom control systems, speakers, and name-brand turntables and cartridges — all available individually at low catalog prices or at money-saving system discounts.



Choose from the nearly 400 quality Heathkit products for home or business, including the world's finest values in amateur radio equipment, complete personal computing systems and educational programs

Every Heathkit product is backed by world-famous technical service and counsel-plus sales and service facilities at 54 Heathkit Electronic Centers* coast-to-coast (*units of Schlumberger Products Corporation).

See the white pages of your phone directory for the center nearest you.

Can Build Yourself...All In This Big

FREE

HEATHKIT® CATALOG!

Have you seen a real computerized, digital home weather station ... or a precision electronic scale for your bathroom ... or advanced educational programs that let you learn electronics or automotive maintenance at home ... or a totally broadbanded amateur radio transceiver ... or the world's only programmable color TV with fully automatic antenna rotor? If you haven't, send for a free Heathkit Catalog.



You'll see nearly 400 unique electronic products — the latest technology, the newest features, the best values. The kind of quality products Heath Company has been offering for some 60 years! It's fascinating reading. But the excitement doesn't stop there.

These sophisticated products are easy to build kits. Illustrated step-by-step instructions guide you and detailed explanations help you learn how the product works from the inside out. It's fun, easy and educational.

...all in this
FREE CATALOG—
get yours now!

If coupon is missing, write
Heath Company, Dept. 020-530
Benton Harbor, Michigan 49022

CIRCLE 100 ON FREE INFORMATION CARD

SEND FOR YOUR FREE COPY TODAY!

HEATH		Heath Company, Dept. 020-530 Benton Harbor, Michigan 49022
Schlumberger		
Please send me my FREE Heathkit Catalog. I am not currently receiving catalogs.		
Name _____		
Address _____		
City _____		State _____
CL-695		Zip _____

**FREE
CATALOG**

How do you really use a multimeter?

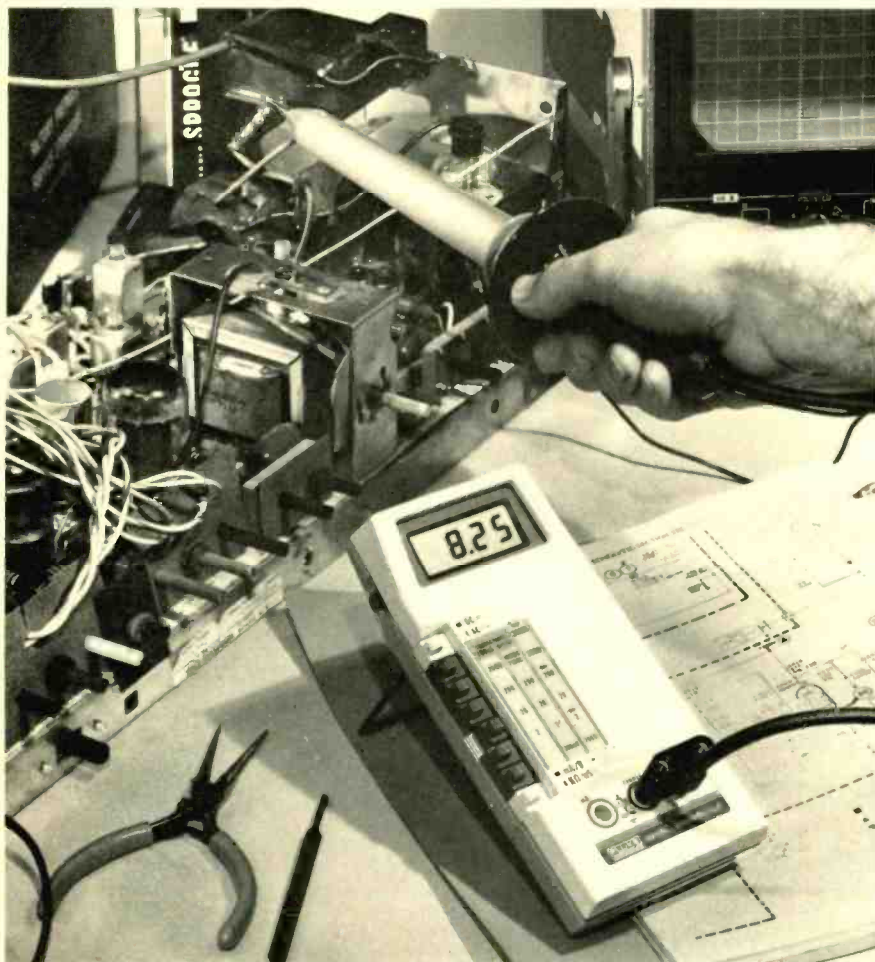

Usually at your bench, in the shop, shared with others. And, if it's a Fluke multimeter, you use it with confidence.

Now you can carry that same bench precision on the job. Introducing the new Fluke 8020A DMM for only \$169.

This rugged beauty packs more field-valuable features than any other DMM available, at any price. And that means field versatility when you need it most.

The 8020A has six resistance ranges, including a 20 megohm range for those special high-resistance TV components. Plus, you can measure focus dividers, pcb and capacitor leakage clear up to 10,000 megohms with the new conductance function. And conductance allows you to measure transistor beta—unique

with the 8020A.

Ever damaged your meter in the fly-back circuit? Rest easy. The 8020A is MOV-protected to 6000V against hidden spikes and transients.

Your 8020A comes with a full-year warranty, with worldwide service backup. Regardless of what happens to it, we'll fix it inexpensively and quickly, making the 8020A a truly cost-effective investment.



8020A DMM \$169.

212-687-2224

THE TEST EQUIPMENT SPECIALISTS

**TOLL FREE HOT LINE
800-223-0474**

54 West 45 Street, New York, N.Y. 10036

**ADVANCE
ELECTRONICS** 

EQUIPMENT REPORTS

continued from page 26

ductor cables, color-coded on one side and colored plain red on the other. This helps identify the position of the edge connector in the chassis socket. The terminal boards used for the socket end of these cables are made with what looks like a good grade of glass epoxy. Printed-circuit wiring on the other side of the board completes the circuit, and jumpers are added where used in the original socket that look as if they would stand up to hard use with no trouble.

I feel these extension module cable kits are a giant step forward in making our job just a little bit easier! The suggested retail prices for the extension cable sets are as follows: the Zenith model KZ-2, \$49.50; the RCA model KRX-5, \$54.50. The sets are available from Sylvania dealers and distributors. "Try 'em, you'll like 'em!" **R-E**

Microproducts Apple II Assembler/Editor

CIRCLE 142 ON FREE INFORMATION CARD

A CORESIDENT ASSEMBLER/TEXT EDITOR FOR the Apple II computer is now available from Microproducts (1024 17th Street, Hermosa Beach, CA 90254). This assembler is supplied on cassette tape, floppy-disc or EPROM, and features line renumbering, printer control and driver software for Microproducts' EPROM programmer. I used the disc-based assembler (Version 2.0), which also allows the program text files to be stored, retrieved and merged from the disc.

Writing in machine language yields fast and efficient programs. However, machine code is tedious and hard to debug. Even with a mini-assembler, such as the one in the Apple II, changing one line of a program usually necessitates a lot of machine code acrobatics. With a true assembler/editor such as the one described here, the program is written into a text file that can easily be read, documented, altered and debugged.

The Apple II assembler supports all standard 6502 mnemonics and address modes. Also included are six pseudo-op codes that allow you to originate variable codes as well as hexadecimal format and ASCII constants or tables. Labels can be 1 to 4 characters long, and the comment field handles up to 16 characters. Using this assembler makes writing machine-language programs almost as easy as using BASIC (well, maybe not quite). But with a little practice even the beginning computer user can break the "BASIC barrier."

I did find one bug that causes the assembler to generate false code—it does not always catch a BRANCH OUT OF RANGE error. Instead, it generates legitimate code, which can play havoc with your program and is very hard to debug. Fortunately, I also found the cure for this problem, and I notified Microproducts so that the company can correct any future units. (If anyone has an old version of this assembler and wishes to correct it, just send a self-addressed, stamped envelope to West Side Electronics, Dept. MP-F, P.O. Box 636, Chatsworth, CA 91311.)

The assembler on cassette tape (No. MP 78101-1) costs \$19.95; on disc (No. MP 78101-3), \$25.00; and on EPROM (No. MP 78101-2), \$40.00 and you must supply the two 5-volt 2716 EPROM's. **R-E**

**Blonder-Tongue's
new boosters are
making a lot of 'noise.'**

Disappear.

With the lowest noise figure on the market for a crisp, clean, clear T.V. reception.

Rather than a bigger, more expensive antenna, a booster may be just what your customers need to get a better picture. Your distributor can tell you. And when he does, ask him about the new line of Galaxy boosters from Blonder-Tongue.

He'll tell you they outperform any other booster made. With a lower noise figure which means less snow . . . a better picture.

So ask him all about the extraordinary new line of boosters Blonder-Tongue has just come out with. They're getting a great reception. Because that's precisely what they give.

Ask your electronics distributor for more information.



CIRCLE 74 ON FREE INFORMATION CARD

Hot Shot.

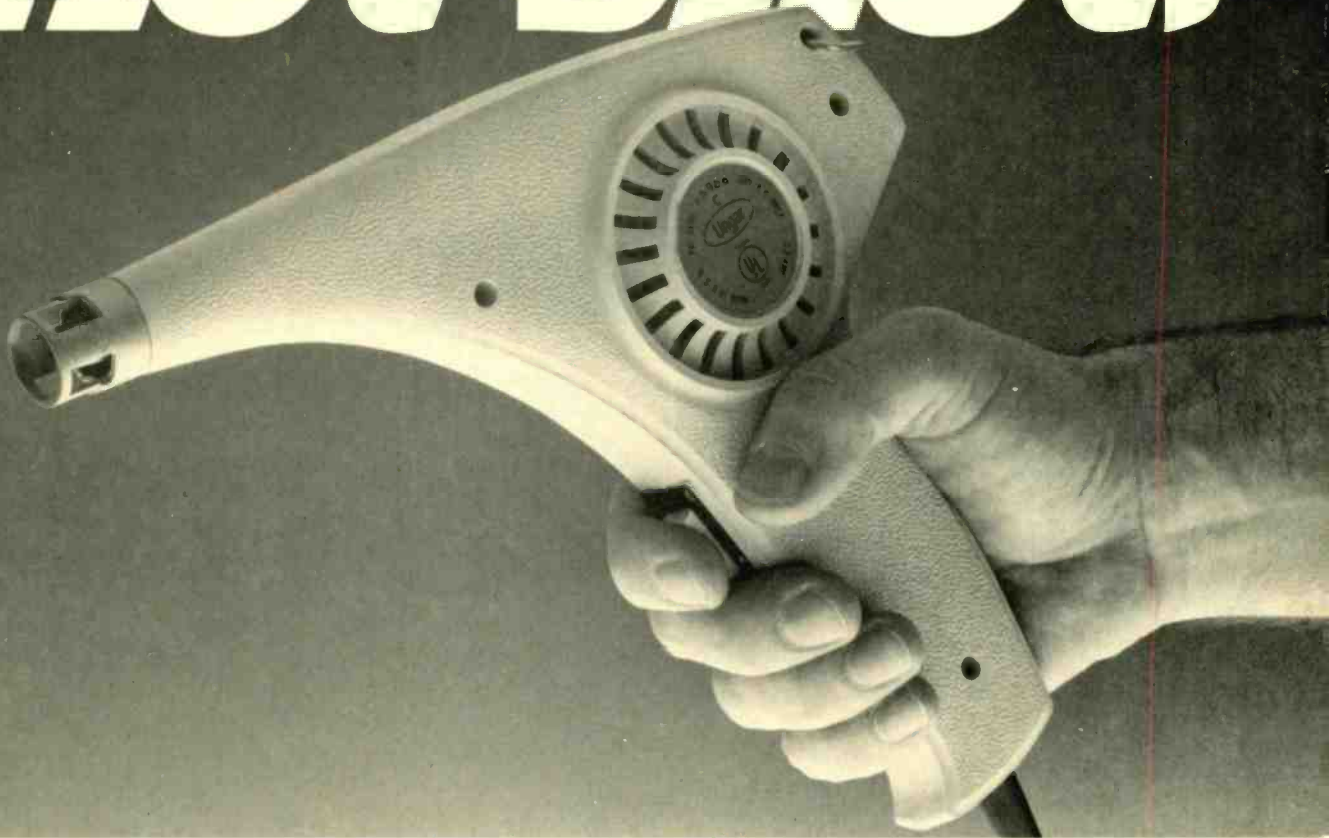

Our heat gun is light, tough and very easy to control. You get easier handling with precise hot air direction and built-in durability.

Weighing only 13 ounces, including its 3-wire cord, the heat gun sits comfortably in your hand. Its handle stays cool even during long hours on the job.

You can put the hot air stream exactly where you want it because the nozzle is smaller. And the four baffles that are included with the gun adapt it for a wide variety of uses.

There's a 3-way trigger switch with hot and cool positions. The nozzle temperature reaches 750° 800°F in seconds. And you can get our optional stand to hold the heat gun securely in several work positions.

In its high impact, heat resis-

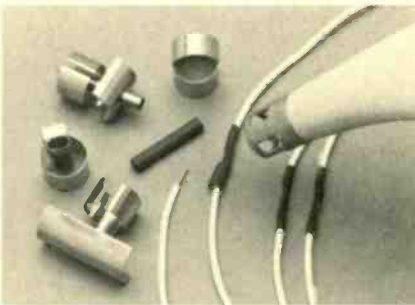

tant molded case, the heat gun can withstand the rigors of industrial, service shop or laboratory use.

Try our versatile, economical heat gun for everything from shrink tubing, to reflow soldering, to repairing plastics. You'll see why half of our heat guns are bought by or on the recommendation of a satisfied user.

For our new catalog, write to Ungar, Division of Eldon Industries, Inc., P.O. Box 6005, Compton, CA 90220.

Ungar.

The Heat Gun. For Precise Control Of Hot Air.

CIRCLE 54 ON FREE INFORMATION CARD

BUILD THIS

Time/Voltage Calibrator

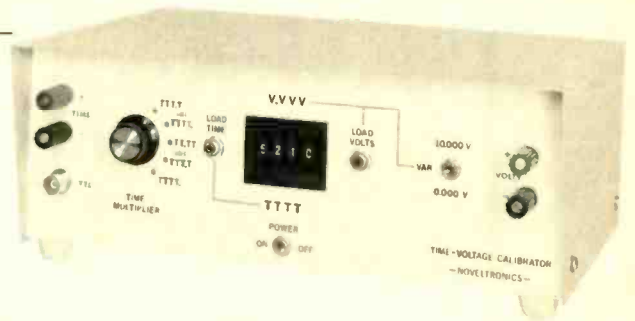

Precision digital test equipment requires special test instruments to insure that calibrations are within specified tolerances. This calibrator supplies time and voltage references you'll need.

DOUG FARRAR

FOR YEARS LARGE COMPANIES HAVE ENJOYED the benefits of highly accurate digital test equipment because only they could afford the substantial initial capital outlay and the periodic maintenance and calibration required in using this equipment. Recently, however, advances in digital and linear-integrated-circuit technology have brought the cost of these test instruments down to a price affordable to even the hobbyist.

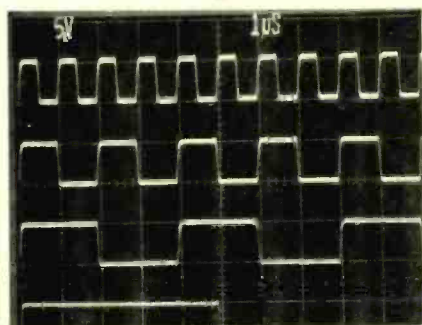
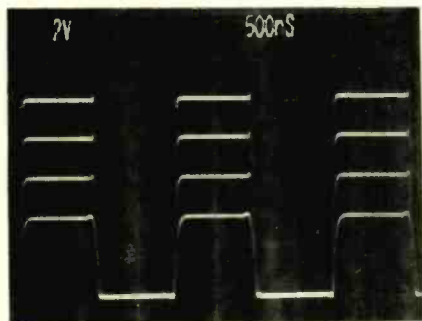

FIG. 1—MULTIPLE EXPOSURES of "time" outputs. At *a* programmed voltages are 4, 6, 8 and 10 with 2.0- μ s period. At *b* we have 5-volt swings at 1, 2, 4 and 10 μ s programmed periods.

However, there is a side to this story that is never mentioned: How is a hob-

byist going to keep his new gear calibrated? In the days of 1% to 5% accuracy, the known voltage of a battery or the approximate resonant frequency of a crystal were adequate enough for calibration standards. Nowadays, a 3½-digit digital voltmeter (DVM) needs a 0.1%-voltage standard; newer scopes need 1% (or better) time standards. And even inexpensive frequency meters need .01% time standards.

Of course, you can routinely send an instrument to a calibration lab (as the manuals tell you to do!), but this could easily become more expensive than the cost of the unit itself. Even if you're willing to do that, you may not have such a lab near you. What's the hobbyist to do?

The Time-Voltage Calibrator de-

scribed in this article can be the answer to your calibration problems, and could pay for itself many times over. This instrument has two separate sections for time and voltage, each controlled by a standard 4-digit thumbwheel-switch network. When you dial in the desired voltage and press the **LOAD VOLTS** pushbutton, a DC-voltage output is produced that is accurate to better than 0.1%. Dialing in the desired time and pressing the **LOAD TIME** pushbutton produces two time outputs with 0.005% accuracy. The first output is a standard TTL output with a duty cycle within 5 ns of 50%. The second time output has slower rise and falltimes than the first, but its voltage swing is highly accurate. The time period is controlled from the front panel, while the voltage

SPECIFICATIONS

VOLT SPECIFICATIONS

Range	0.000 to 10.000 volts in 1-mV steps
Total error	< $\pm 0.1\%$ of setting (untrimmed) < $\pm 0.05\%$ of setting (trimmed)
Settling time	stable to 1 mV within 15 seconds
Trim range	± 20 mV

TIME SPECIFICATIONS

Range	000.0 to 999.9 μ s in 0.1- μ s steps
Multiplier	$\times 1$, $\times 10$, $\times 100$, $\times 1,000$, $\times 10,000$
Total error	< 50 ppm (.005%) of setting (untrimmed) < 5 ppm (.0005%) of setting (trimmed)
Trim range	± 30 ppm, typical

	Time	TTL
V_{OL}	0 volts	< 0.4 volts
V_{OH}	programmed by VOLTS section; approx. 4 volts (min.), + 10 volts (max.), ± 10 mV	> 2.4 volts
Output impedance	< 100 ohms (typ.)	normal TTL
Rise/falltimes	< 50 ns (typ.)	< 5 ns
Duty cycle	within 20 ns of 50%	within 5 ns of 50%

swing is between ground and whatever is dialed into the volts section (± 10 mV). This last time output is very useful for calibrating oscilloscopes.

The maximum programmable output voltage is 10.000 in 1-mV steps. The time output is from 0.1 μ s to 999.9 μ s in 0.1- μ s steps; but a multiplier switch can be used to multiply all these time increments by 10, 100, 1000, or 10,000, even while maintaining the 0.005% accuracy. This results in a maximum time output of 9.999 seconds. The scope photos in Fig. 1 show some of the waveforms obtainable with the Time and Voltage Calibrator.

The best part about the entire project is that it requires no calibration to meet

these specifications! Using the components called out in the parts list, means you now have your own secondary time and voltage standards that are traceable to the National Bureau of Standards (NBS). But if you do have access to very accurate time- and voltage-measuring equipment, the calibrator can be trimmed to even tighter specs.

How it works

There are two almost separate sections to the calibrator: time (Fig. 2) and voltage (Fig. 3). Both sections are loaded with the thumbwheel-switch network, S1-S4 (Fig. 4). Two separate sets of latches (IC1-IC4 and IC5-IC8) latch the

state of the thumbwheels when their respective LOAD switches (LOAD VOLTS, S6 and LOAD TIME, S7) are depressed and then released. So, after a value is loaded into either set of latches, the thumbwheels can be set to any other value.

Let's examine the time section first. The design goals for this circuitry were:

- Time increments of 0.1 μ s;
- A squarewave output;
- A time range of 000.0 through 999.9 μ s, with a time multiplier on top of this.

To accomplish the first two goals, a divide-by-n counter, where n is the thumbwheel-latch value, is clocked at a 20-MHz rate (50-ns time period), and

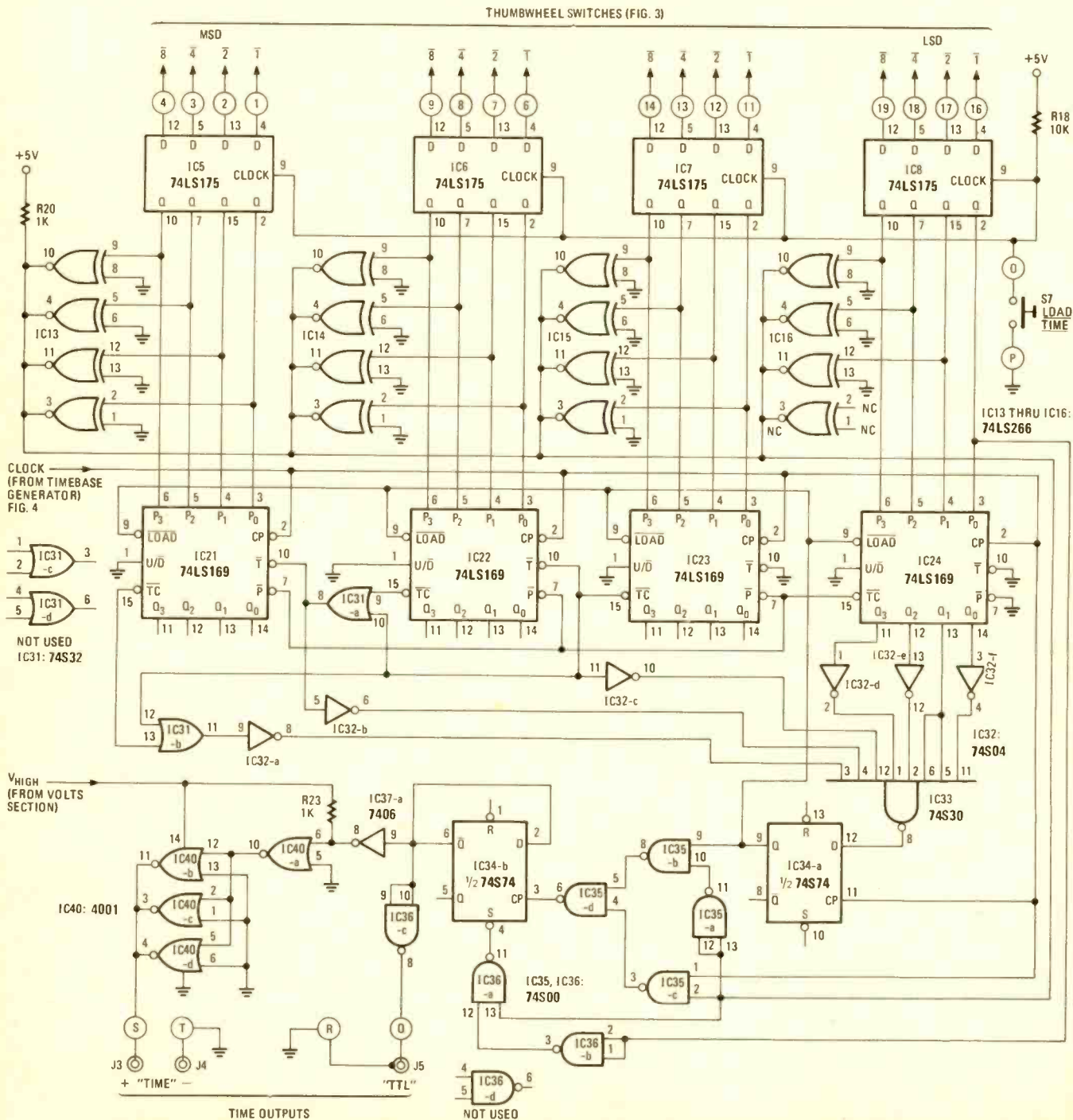

FIG. 2—THE TIME SECTION of the calibrator. Four thumbwheel switches select the time period of the waveforms at the TIME and TTL outputs when pushbutton S7 is depressed.

the counter output is divided by two to produce a squarewave with a time step of $2 \times 50 \text{ ns} = 100 \text{ ns}$ (or $0.1 \mu\text{s}$). The third and last design goal requires a four-decade counter network. By reducing the

counter's clock frequency by 10, 100, 1000 and 10,000, the time output can be multiplied by a similar number.

Decade up/down counters IC21-IC24 are wired in the down-count mode, with

IC21 being the most significant stage and IC24 the least significant. These IC's form a divide-by-n counter stage, where the value of n ranges from 2 to 9999. When the counter reaches a value of

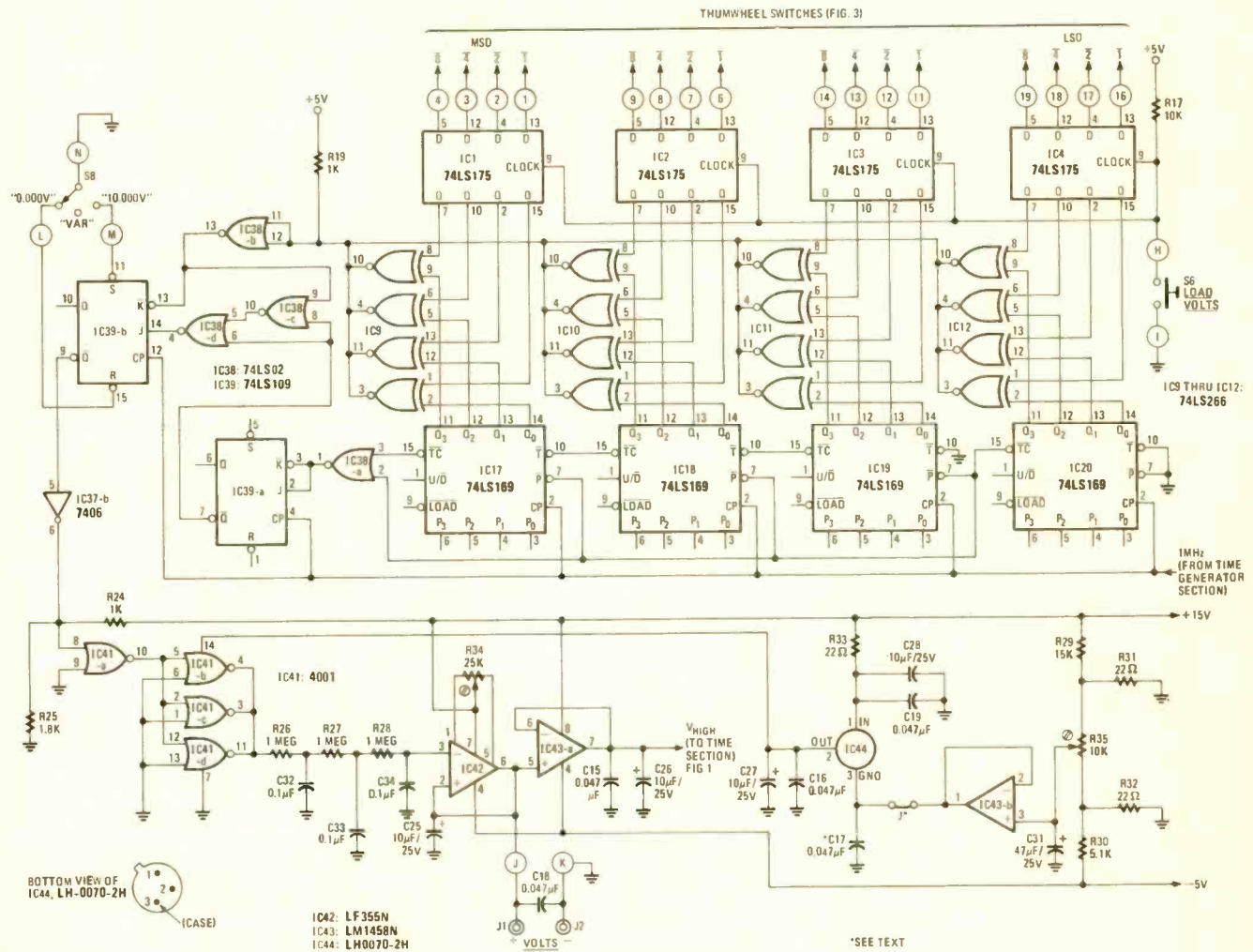

FIG. 3—THE VOLTAGE CALIBRATOR is based on a precision 10-volt reference that can be processed to deliver voltages down to 0 in 10-mV steps.

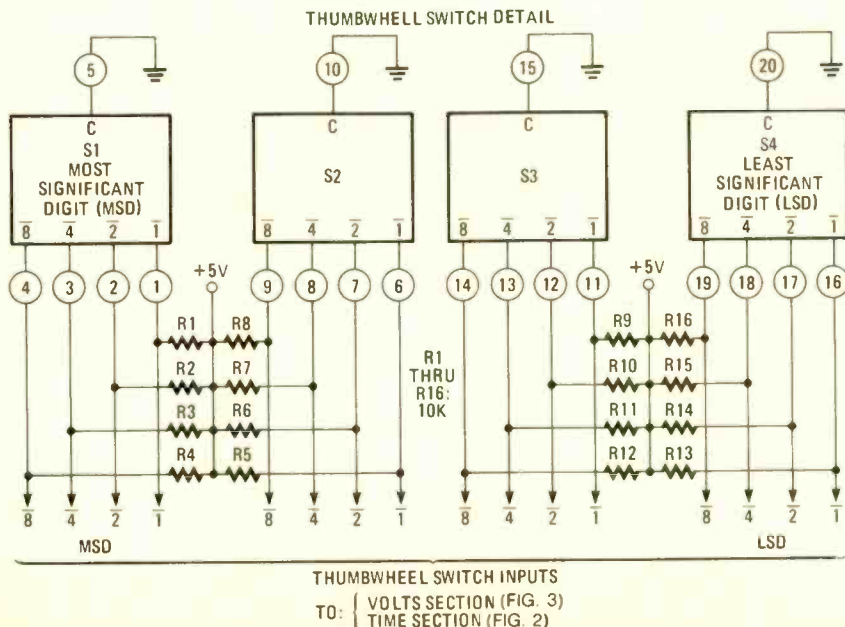

FIG. 4—THUMBWHEEL SWITCHES are BCD-complement types that provide the binary equivalent of analog numbers selected. Resistors R1 through R13 are pull-up resistors.

0002, all inputs to NAND gate IC33 go high, forcing the gate's output to a logic low level. This output drives the data input of the D-type flip-flop, IC34-a. On the next clock, IC34-a's output (Q) goes low, while the counter decrements to 0001. The output of IC34-a is connected to all four counters' synchronous parallel load inputs, so the counters are now prepared for a synchronous load on the next clock cycle, and will load the latched value of n from the thumbwheel switches at that time. The counter stage decrements in the following sequence:

$$n \rightarrow (n-1) \rightarrow (n-2) \dots 3 \rightarrow 2 \rightarrow 1 \rightarrow 0 \dots$$

So loading the n-value produces a low output from IC34-a every n clock cycles. Dividing this signal with a divide-by-two flip-flop (IC34-b) produces the desired squarewave output, and every step in n is a $0.1\text{-}\mu\text{s}$ change in the resulting squarewave output.

Invariably, a value of 0000 or 0001 will be loaded into the time section. Since a divide-by-zero or a divide-by-one counter does not exist, the circuitry would produce an ambiguous output. To circum-

vent the problem, an open-collector exclusive-NOR network consisting of IC13-IC16 is used as a comparator to monitor the latches' loaded value. When a 0000 or a 0001 is loaded, the OR-tied output of the comparator gates goes high, signaling the logic that this special condition now exists. The comparator output drives IC35-c-2, IC35-a and IC36-a (IC35 is wired as a 1-of-2 multiplexer). When the comparator output is low, the multiplexer selects the divide-by-n output to be applied to the clock input of divide-by-two flip-flop IC34-b, as discussed above. But when the comparator output is high, the multiplexer selects the down-counters' clock input as the clocking signal to IC34-b. This produces a divide-by-2 squarewave of 20 MHz, or 10 MHz, which is a 0.1- μ s period. But if a 0000 is loaded into the time thumbwheel latches, the input of NAND gate IC36-b is low, causing its output to go high. This means that both inputs to IC36-a are high, and the overriding asynchronous SET input to IC34-b is activated. The divide-by-two flip-flop output is now always low, regardless of the inputs on the synchronous inputs, producing a period of 0, as required.

The time-counter network can generate the correct squarewave for any value from 0 to 9999. All that remains to be done is to buffer the squarewave before applying the signal to the front panel. Buffer IC36-c inverts IC34-b's output, and is a standard TTL output (i.e., it has a precise time but no amplitude control). Open-collector buffer IC37-a drives CMOS buffer network IC40. This output swings between ground and its V_{DD} input (indicated as V_{HIGH} on the schematic diagram), which is a DC signal coming from the volts section (to be discussed shortly). While the rise and falltimes from buffer IC40 are slower than that of a TTL output, the amplitude and period are very accurate. However, reliable operation below about 4.5 volts cannot be expected.

Getting the time-counter network to operate at 20 MHz is not easy and requires more circuitry than a slower counter chain. Integrated circuit 31, IC32, IC33 and IC34 perform the necessary high-speed logic operations. It is important that these IC's be Schottky-type IC's, and not low-power Schottky or standard TTL types. Furthermore, if you believe in worst-case numbers, down-counters IC21-IC24 should be manufactured by either Fairchild, Motorola, or Raytheon, since the worst-case speed specifications of these companies are tighter than those of other makes. The "slower" devices may result in the counters not working with some n counts!

Up to this point, it has been assumed that the time counters work with a 20-MHz clock input. If a 2-MHz clock rate is used instead, each least-significant thumbwheel step would be 1.0 μ s, rather

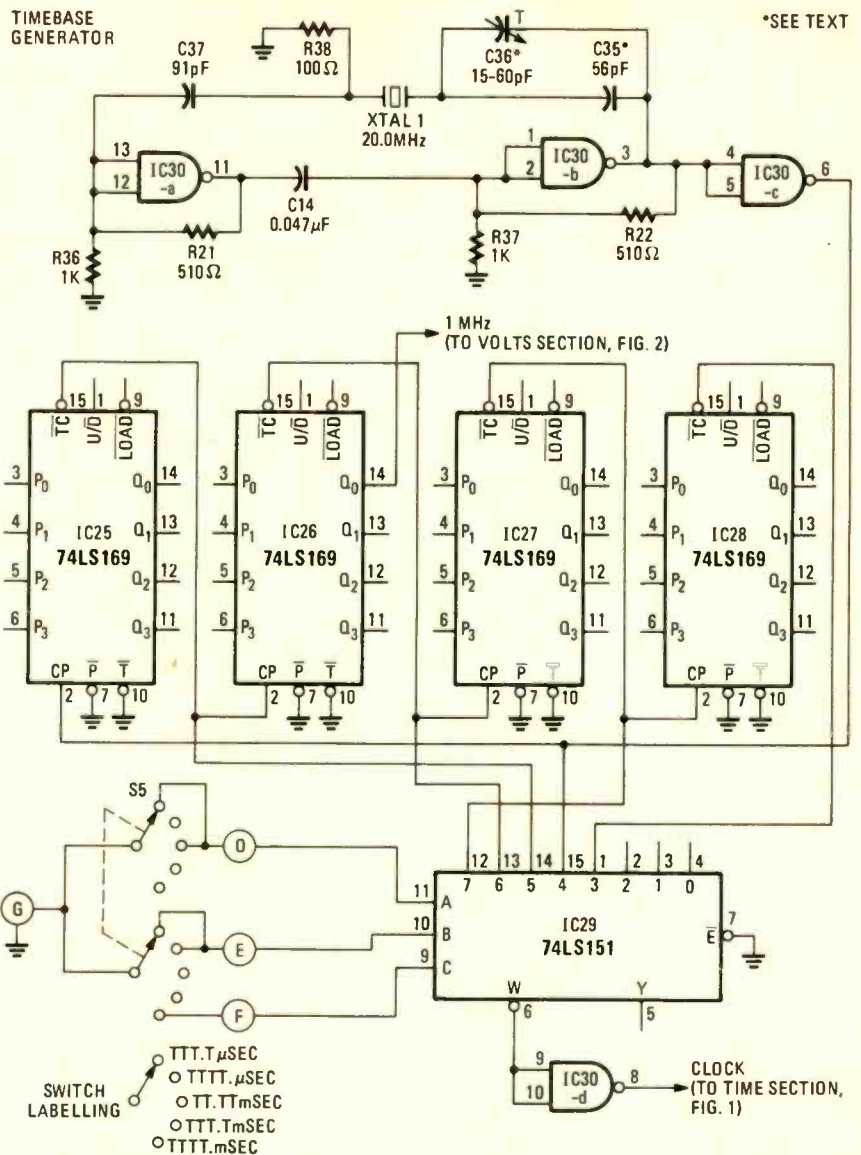
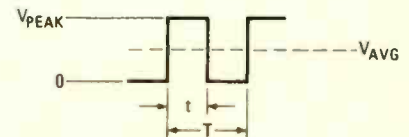

FIG. 5—DECADE COUNTERS in ripple configuration divide the 20-MHz clock frequency by a factor of 10 per counter.

than 0.1 μ s. Furthermore, 200-kHz, 20-kHz and 2-kHz clock inputs would produce minimum steps of 10 μ s, 0.1 ms and 1.0 ms, respectively. Generating these clock rates is a simple task, assuming that the 20-MHz frequency already exists. Decade counters IC25-IC28 (Fig. 5) are hooked up to divide the 20-MHz clock by factors of 10-per-counter.

The 20-MHz signal and the four counter outputs are connected to multiplexer IC29. Use of the multiplexer and TIME MULTIPLIER switch S5 allows front-panel "cold-switch" selection of a single clock to be applied to the time section. That is, a set of DC signals can select one AC signal to be applied to the time counters, thus avoiding the need to route the noise-producing AC signals to the chassis's front panel. The output of the multiplexer is buffered by IC30-d before being applied to the time calibrator's clock inputs.

The NAND gates, IC30-a and IC30-b, are the amplifying components of the crystal oscillator, whose frequency is set



$$V_{AVG} = V_{PEAK} \times DC/100$$

WHERE V_{PEAK} IS THE PEAK VOLTAGE
DC IS THE WAVEFORM DUTY CYCLE ($= \frac{t}{T}$)

FIG. 6—CHARACTERISTICS of the squarewave that determines the average voltage.

by the 20.0-MHz crystal. The NAND gates introduce a small amount of loop delay that is compensated for by the paralleled capacitor combination of C35, trimmer C36, capacitor C37 and resistor R38. Resistors R21, R22, R36 and R37 bias the gates in their linear regions. The oscillator output is buffered by IC30-c before being applied to the multiplexer and countdown string.

The volts calibrator: how it works

Anyone who has designed an automobile dwellmeter will recognize the operational principle behind the programmable

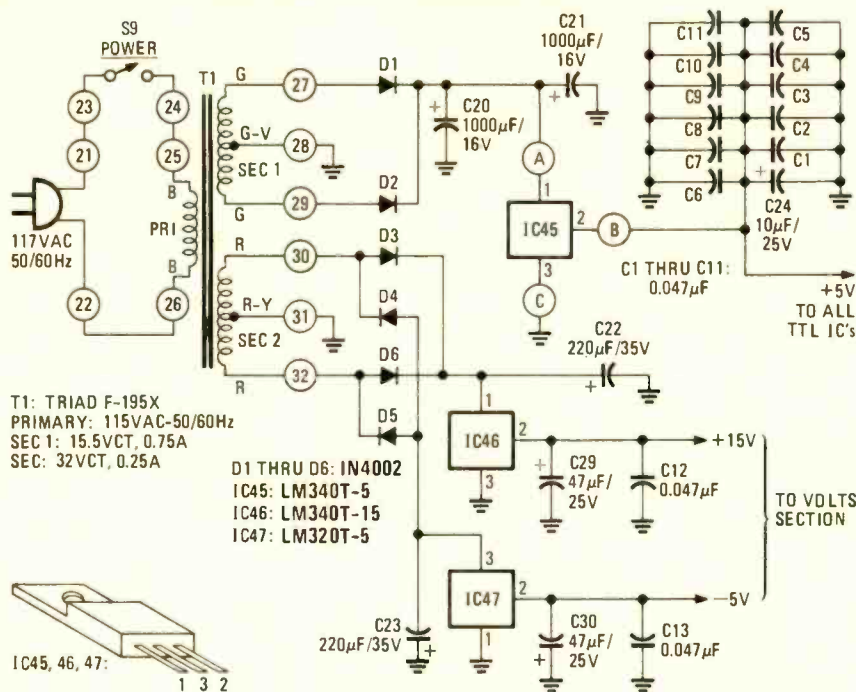

FIG. 7—POWER SUPPLY CIRCUIT. The power transformer with its two secondaries, supplies the IC voltage regulators that deliver the three regulated voltages used in the calibrator.

voltage generator. If a rectangular-wave voltage is allowed to swing between ground and some known voltage with some known duty-cycle, then the average voltage is given by the equations shown in Fig. 6.

So, with a duty-cycle of 0, the waveform never switches but remains at ground, and $V_{AVG} = 0$. A duty-cycle of 100 means that the waveform remains at V_{PEAK} , so $V_{AVG} = V_{PEAK}$. A duty-cycle at any point between the two extremes pro-

duces an average voltage between 0 and V_{PEAK} , as shown by the Fig. 6 equation.

How can this principle be used here? It's easy to generate an extremely accurate duty-cycle using standard digital technology. However, where do you obtain an accurate voltage source? Here comes linear IC technology to the rescue! National Semiconductor produces a linear IC voltage reference that is laser-trimmed to 10.000 volts. This IC comes in two accuracy grades: -1H is 10.000 volts ± 10 mV ($\pm 0.1\%$), while -2H is ± 5 mV ($\pm 0.05\%$). The latter value is specified here for the ultimate in untrimmed accuracy.

How do you generate an AC rectangular waveform that swings accurately between 0 and 10.000 volts; does it with the desired duty-cycle; and exhibits insignificant rise and falltimes between the two voltages? The answer is surprisingly simple: All CMOS circuits switch their outputs between ground and their supply voltage, V_{DD} . Because FET's behave in a resistive manner, there is no offset voltage at the outputs to contend with, as in TTL logic circuits. Thus, by applying the 10.000-volt reference to V_{DD} of a CMOS gate, and applying the specified duty-cycle to the gate's input, the desired signal conditioning appears at the CMOS output. All that remains to be done is to

continued on page 104

PARTS LIST

Resistors are 5%, 1/4 watt unless otherwise noted

- R1-R18—10,000 ohms
- R19,R20,R23,R24,R36,R37—1000 ohms
- R21, R22—510 ohms
- R25—1800 ohms
- R26-R28—1 megohm
- R29—15,000 ohms
- R30—5100 ohms
- R31-R33—22 ohms
- R34—25,000-ohm, PC-mount trimmer
- R35—10,000-ohm, PC-mount trimmer
- R38—100 ohms

Capacitors

- C1-C19—0.047 μ F, 25 volts, ceramic disc
- C20, C21—1000 μ F, 16 volts, radial electrolytic
- C22, C23—220 μ F, 35 volts, radial electrolytic
- C24-C28—10 μ F, 25 volts, radial electrolytic
- C29-C31—47 μ F, 25 volts, radial electrolytic
- C32-C34—0.1 μ F, 50 volts, Mylar
- C35—56 pF (or 91 pF), 50 volts, mica (see text)
- C36—15-60-pF trimmer (see text)
- C37—91 pF, 50 volts, mica

Semiconductors

- D1-D6—1N4002, 1A, 100-volt diode
- IC1-IC8—74LS175, quad D-type flip-flop
- IC9-IC16—74LS266, quad exclusive NOR gate
- IC17-IC20—74LS169, 4-bit up-down decade-counter
- IC21-IC28—74LS169 (Fairchild, Motorola or Raytheon, see text) 4-bit up-down counter

- IC29—74LS151, 8-input multiplexer
- IC30, IC35, IC36—74S00, quad 2-input NAND gate
- IC31—74S32, quad 2-input OR gate
- IC32—74S04, hex inverter
- IC33—74S30, 8-input NAND gate
- IC34—74S74, dual D-type flip-flop
- IC37—7406, hex inverter, open-collector
- IC38—74LS02, quad 2-input NOR gate
- IC39—74LS109, dual J-K flip-flop
- IC40, IC41—CD4001, quad 2-input CMOS NOR gate
- IC42—LF355N (National) JFET op-amp
- IC43—LM1458N (National) dual op-amp
- IC44—LH0070-2H (National) 10-volt reference
- IC45—LM340T-5 (National) 5-volt positive regulator
- IC46—LM340T-15 (National) 15-volt positive regulator
- IC47—LM320T-5 (National) 5-volt negative regulator

Miscellaneous

- S1-S4—Thumbwheel switches, BCD-complement, Unimax SF-18 or equal (Unimax Switch Corp., Ives Rd., Wallingford, CT 06492)
- S5—2-pole, 5-position rotary switch (CTS T-206 or equal)
- S6, S7—Momentary, normally open switch
- S8—SPDT, ON-OFF-ON switch
- S9—SPST switch
- J1-J4—5-way binding post
- J5—BNC female, panel-mount connector
- XTAL1—20.0-MHz quartz crystal, series-resonant, .005% or better tolerance, HC18/U holder

Thumbwheel switch end plates; line cord; strain relief; case (LMB #ME-7114); 4-40 \times 1/2-in. hardware; knob; 1/2-in. aluminum strips; wire and coax; BNC receptacle and ground lug; PC board; and dry transfer letters.

The following components are available postpaid from Noveltronics, P.O. Box 4044, Mountain View, CA 94040:
CK-TVC: Complete kit of parts and hardware—PC board, special 2-color dry transfer chassis lettering sheet, and unpunched chassis, \$150.

PK-TVC: Partial kit—complete thumbwheel switch assembly, LH0070-2H, transformer, crystal, case, special dry transfer lettering sheet, and PC board, \$100.

PCB-TVC: Etched, drilled and silk-screened PC board, \$25.

California residents add state and local taxes to the total order. Individual items are not available for sale. Orders paid by money order or bank-certified check can be discounted 5%, and guarantee shipment within 2 shipping days after receipt of order. Allow up to 2 weeks delay for personal check clearance time. No out-of-state P.O. boxes, please. Canadian and Mexican orders add 5% (non-discountable) of order, all other non-USA orders add 10% (non-discountable) to cover additional postage and handling. U.S. funds only.

BOWLING MAY BE ONE OF OUR EARLIEST sports, with origins dating back to the Egyptians of 5200 BC. Almost five million Americans bowl in sanctioned leagues, and over sixty million more bowl for recreation or exercise. However, it is hard to find a functional yet reasonably priced toy bowling game for the home. The game described in this article can be built to almost any size, uses materials that are easily obtainable and priced reasonably and is a faithful representation of the real thing.

Playing the game

Depending on the size of the alley you want to build, various objects can be selected as a "ball" or puck. I chose to size everything around a quarter (a twenty-five cent coin), but you could use a poker chip or any other circular opaque object. When the game is turned on and reset, all 10 display LED's are dark. If the "ball" slides down the alley and passes over several of the "pin" spots the photo-Darlington transistors embedded in the lane are blocked from light. This change in state is remembered by the internal CMOS bistable latches, and the display LED's indicate which pins would have been knocked down in a real game had the ball taken a similar path. For example, striking the 1 and 2 pins but missing the 3 pin is the same as hitting the "pocket" and it gives you a strike. Hitting the 1, 2 and 3 pins results in that nemesis of all bowlers, the 7-10 split. Other ball paths are similarly translated into the equivalent pin knockdown. If you get a "spare," (i.e., less than 10 pins are knocked down), the second ball is then thrown. Again, the gating tells the display which pins have been knocked down. For more realism, all the spares can be picked up except for the 7-10 split, which is unmakeable. After a strike or the second ball, pressing the RESET pushbutton clears the display for the next bowler. Scoring is done exactly as in real bowling; you can obtain bowling score sheets from a local bowling establishment.

The circuit

The block diagram in Fig. 1 shows the sequence that occurs when a ball or puck such as a quarter passes over the pin area of the board. Each of the front seven pin locations has a photo-Darlington transistor inserted in a slot flush with the lane surface. Normal room lighting is sufficient to cause logic-level switching when the photosensitive area is covered by the ball. Each phototransistor (Fig. 2) is wired to its own bistable latch circuit, which "remembers" a pass of the ball by flipping states. These latches, in turn, feed a series of CMOS AND gates (Fig.

BOWLING GAME

CHARLES L. STANFORD

If your gameroom is too small for that full-size bowling alley you've always wanted, here is an electronics-based bowling game for you to try.

3), which are wired to detect various pin combinations. A total of 30 gates in 10 IC packages is connected to provide 21 separate and distinct outputs. While there is no way to show the effect of a hook ball or a pin bouncing off the side boards, every possibility of one or two balls going over the pin area is considered. See Table 1 for the various input combinations and the resultant displays.

Twenty-one of the outputs are diode-Or'ed into a diode matrix ROM (Read Only Memory) with seven horizontal-input lines and 10 vertical-output lines (see Fig. 4). The input lines each have connecting diodes at the appropriate junctions of the output lines to drive the 10 display LED's.

The power supply for this circuit (Fig. 5) is noncritical since switching speed is not important. Any handy holder for 4 C or D batteries will suffice. I omitted the batteries and used a 6-volt calculator battery eliminator from my junk box instead. Diode D1, capacitor C1 and

resistor R1 provide the needed rectification and protection against reverse polarity and power surges. Note that both supplies can be installed if a shorting-type jack is used; standard dry cells can leak or explode if charging is attempted. A battery eliminator of from 4.5 to 12 volts can be used if LED current-limiting resistors R20-R29 are changed in value; the CMOS IC's will function on any DC supply between 3 and 15 volts.

Construction

Before starting construction, decide on the size of the ball. I chose a quarter, since the alley is a convenient size for table-top play and there is no danger of losing the ball and not easily finding another. The dimensions shown in Fig. 6 for constructing the lane, gutters and phototransistor holes are all determined by the diameter of a quarter. If a different size "ball," such as a poker chip, is chosen, all these dimensions must be multiplied by the ratio of the diameter of

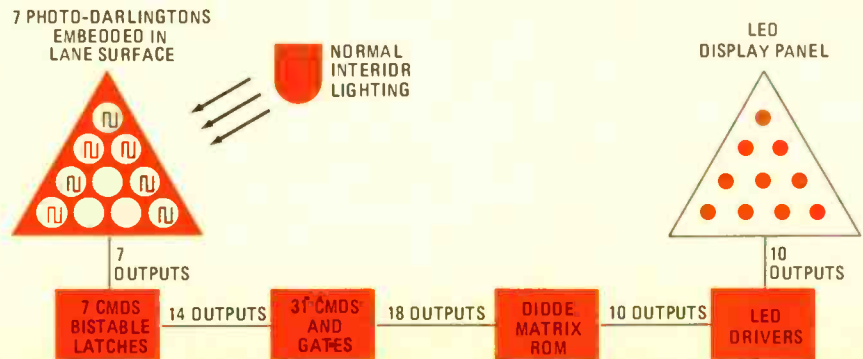

FIG. 1—BLOCK DIAGRAM of the bowling game. Action flows from pins at left to display at right.

the chosen ball to that of a quarter (this is approximately $1/16$ inch). In addition, you must be careful to shape the circuit board (see Fig. 7) so that it fits under the alley.

While an etched PC board could have been developed for this project, the labor and cost involved would have exceeded that of the rest of the components combined. This game, with its low-cost IC's and relatively straightforward schematic diagram, is a natural for wire-wrapping techniques. I went one step farther and used a modification of the IC bricklaying method (see "IC Bricklaying," *Radio-Electronics*, December 1977). The IC's were glued upside down to a sheet of $1/8$ -inch clear plastic, and the pins were direct-wired using a wiring pencil. Anyone trying this, however, must accept the risk of static damage to the sensitive CMOS IC's. A safer procedure is to use multilevel wire-wrap sockets on perforated board and connect the pins with several colors of 30-gauge Kynar-insulated wire.

First, insert the sockets in their relative locations, being careful to leave room for mounting the hardware and other components (see Fig. 7 for general guidelines and dimensions). At this point, it is generally easiest to wire the positive and ground leads on all IC's, using 22-gauge hookup wire and soldering them flush

Pin Code	Gate Combinations	Gate Output	Diode Matrix Input Lines	Diode Matrix Outputs											
				1	2	3	4	5	6	7	8	9	10		
1 2 3	B (1 2 3)	B	11, 14, 16	1	1	1	1	1	1	1	1	1	1	1	1
1 2 3	C (1 2 3)	C	11, 14, 16	1	1	1	1	1	1	1	1	1	1	1	1
1 2 3 4 6 7 10	A (1 2 3) & E (4 6 7 10)	N	11	1	1	1	1	1	1	1	1	1	1	1	1
1 3 4	H (1 4) & 3	U	12	0	0	1	0	1	0	1	1	1	1	1	1
3 4 6 7 10	M (3 4) & 6 7 10	T	13	0	0	0	0	1	0	0	1	1	1	1	1
1 4 6 10	H & L (6 10)	V	14	0	0	0	0	0	0	0	0	0	0	0	1
2 4 6 7 10	J (2 4) & G (6 7) & 10	P	15	0	0	1	0	0	1	1	0	0	1	1	0
1 4 6 7	H & G	W	16	0	0	0	0	0	0	1	0	0	0	1	0
1 2 3 10	A & 10	X	11, 14	1	1	1	1	1	1	1	1	1	1	1	1
1 2 3 6	A & 6	Y	11, 14	1	1	1	1	1	1	1	1	1	1	1	1
1 2 3	K (1 2) & 3	Z	12, 17	0	1	1	1	1	1	1	1	1	1	1	1
2 3 4 6	J & 3 6	Q	12, 15	0	0	1	1	1	1	1	1	1	1	1	1
1 3 4 7	H & 3 7	R	12, 16	0	0	1	0	1	1	1	1	1	1	1	1
2 3 4 6	F (2 3 4 6)	F	13, 17	0	1	0	1	1	1	1	1	1	1	1	1
2 4 6 7 10	J & D (6 7 10)	AA	13, 15	0	0	0	1	1	1	1	1	1	1	1	1
1 2 6	K & 6	BB	17	0	1	0	1	0	1	1	0	1	1	1	0
2 4 6 7 10	J & G & 10	S	14, 15	0	0	0	1	0	0	1	1	0	1	0	1
1 2 3 4	A & 4	CC	11, 16	1	1	1	1	1	1	1	1	1	1	1	1
1 2 3 7	A & 7	DD	11, 16	1	1	1	1	1	1	1	1	1	1	1	1
3 4 6 7 10	M (3 4) & D	EE	13, 16	0	0	0	0	1	1	0	1	1	1	1	1
1 2 6 10	K & L	FF	14, 17	0	1	0	1	0	1	1	1	1	1	1	1

with the PC board. This both holds the sockets in place and provides a pin reference. Note the nonstandard connections of IC's 15 and 16. Now, install R1 and R2 through R8, C1, D1 and the 22-gauge wires that will later be connected to S1, J1 and B1 (if used). Finally, label each socket and mark the pin 1 locations on both sides of the board.

Wiring between the pins of IC's 1-14 will be easier to perform and trace if one wire-insulation color is used for all the number-designated pins (1, 1, 2, etc.) and another color is used for all lettered pins A through FF. Start by connecting all the pins of each designation together, as shown in Fig. 8. For example, 1 (which means "not one") is found at IC1 pins 2

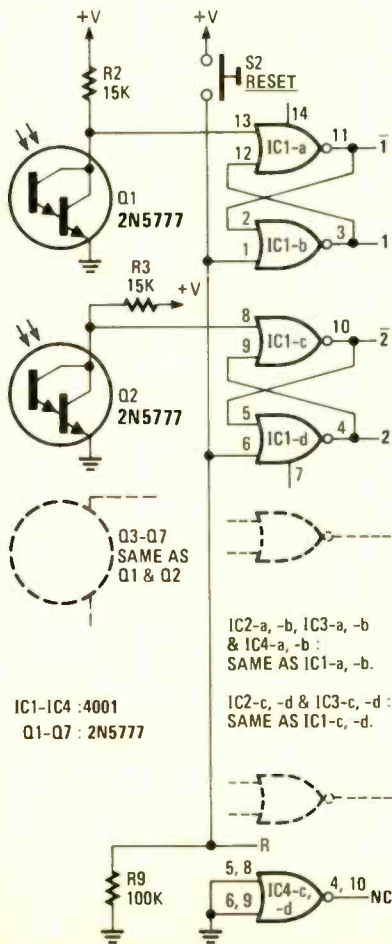

FIG. 2—DARLINGTON phototransistors Q-Q7 are wired to bistable latches using NOR gates.

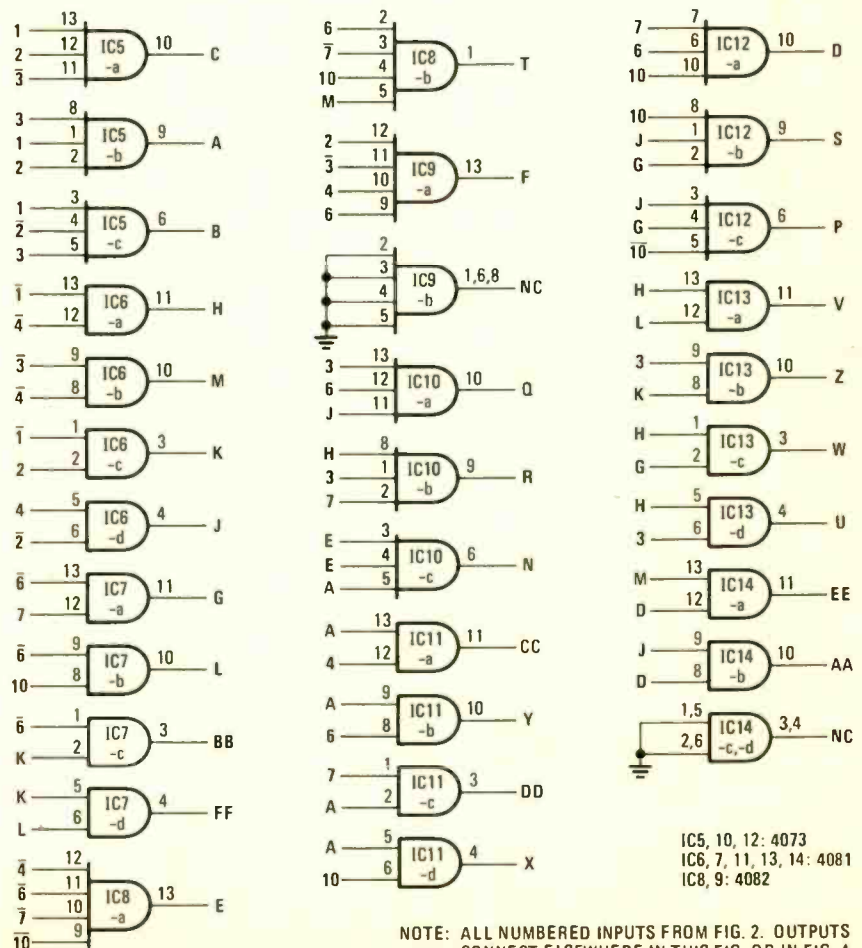
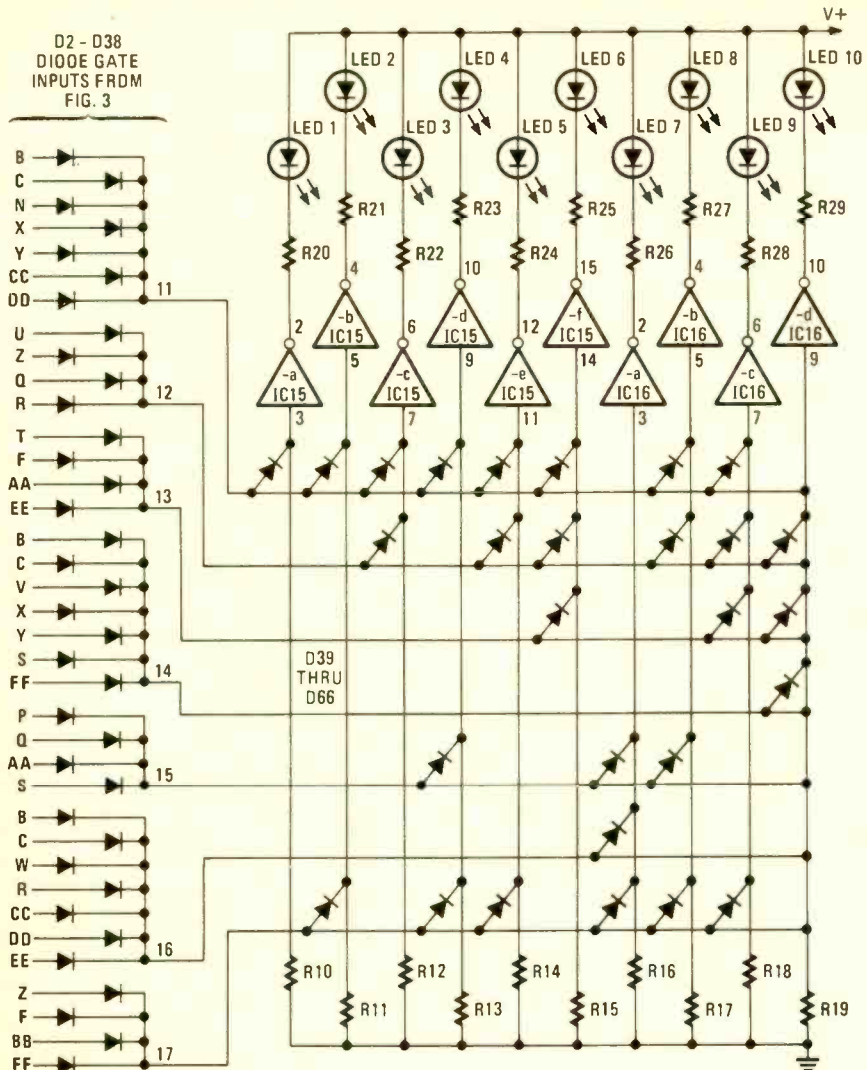

FIG. 3—THIRTY AND GATES provide 21 outputs generated by input from the phototransistors.



NOTES:

D2 - D66 = 1N914
 R10 - R19 = 100K
 R20 - R29 = 220 OHMS

IC15 = 4049
 V+ : PIN 1.
 GND : PIN 8.
 NC : PINS 13 & 16.

IC16 = 4049
 V+ : PIN 1.
 GND : PINS 8, 11 & 14.
 NC : PINS 12, 13, 15 & 16.

FIG. 4—DIODE OR GATES feed into a diode read-only-memory with seven horizontal input lines and ten vertical output lines. Ten inverters fed by the output lines, control the LED indicators.

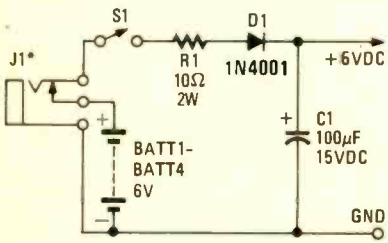

*SEE TEXT

FIG. 5—THE POWER SUPPLY. A 6-volt battery or four flashlight cells can be used away from AC lines. See text on AC input voltages.

and 11 and IC6 pins 1 and 13. Continue making pin connections until all numbered inputs have been checked off. Then, change wire colors and connect the pins with letter designations. Connect resistors R2-R8 to their respective leads on IC's 1 to 4 and to V+ at the power supply. Also connect all the pins designated R to each other and to R9; ground the other end of R9.

The diode matrix and its inputs (see Fig. 4) come next. Diodes D2-D38 com-

prise a wired-OR circuit. Generally, the outputs of CMOS gates cannot be connected, since an off gate directly connected to an on gate would short the power-supply rails through the IC's. However, small-signal diodes can be used instead of additional gates to avoid this problem. Insert the bent leads of the diodes through the circuit board from the top with the anodes nearest the IC sockets. Then, connect the appropriate lettered outputs to their respective diodes.

Using a felt-tip pen, draw the horizontal matrix lines on the board and mark the locations of matrix diodes D39-D66. Insert the unbent anode leads through the board from the top. Run a piece of bare 22-gauge hookup wire from the cathodes of the groups of OR diodes across each line, wrapping once around each matrix diode. Solder snugly against the board so the diodes stand erect on the other side of the board. The 10 bias resistors, R10-R19, are similarly inserted from the top and wired in parallel to ground.

Now, turn the circuit board over and connect a wire up each of the 10 vertical lines of diodes, starting at the resistor. Thread these leads through the board and connect to their respective pins of IC's 15 and 16. Finally, connect the output pins of IC's 15 and 16 to resistors R20-R29.

Building the cabinet

The construction of the alley is quite straightforward, requiring only simple hand tools, a few pieces of tempered *Masonite* or other smooth-surfaced board and some pine strips. First, cut both of the lane base pieces to the dimensions determined by the chosen ball size. Note that the T-shaped piece is the actual bowling surface and be careful not to mar or gouge it. Carefully mark and drill the photo-Darlington transistor mounting holes. Now, paint in a contrasting color the part of the bottom (rectangular) board that will be exposed as the gutters. Use black paint if a light shade of board is available, and white paint if you use dark *Masonite* or paneling. Do not paint the entire board because the glue will adhere better to bare wood or fiber. Next, glue the two pieces together.

When the lane is thoroughly dry, assemble it to the side boards using the 3/4-inch or 1-inch-square corner braces and glue.

When all the glueing is complete and set, drill two very small holes (1/16 inch or less) through the bottom lane piece near the edge of each of the front seven transistor mounting holes. Snip off the base lead of photo-Darlington transistors

PARTS LIST

- Resistors, 1/4 watt, 10% unless otherwise noted**
 R1—10 ohms, 2 watts
 R2-R8—15,000 ohms
 R9-R19—100,000 ohms
 R20-R29—220 ohms
 C1—100 μF, 15 volts, electrolytic
 D1—1N4001 or equal
 D2-D66—1N914 small-signal diode
 Q1-Q7—2N5777 photo-Darlington transistor
 IC1-IC4—4001 quad 2-input NOR gate
 IC5, IC10, IC12—4073 triple 3-input AND gate
 IC6, IC7, IC11, IC13, IC14—quad 2-input AND gate
 IC8, IC9—4082 dual 4-input AND gate
 IC15, IC16—4049 inverting-type hex buffer/converters
 LED1-LED10—Jumbo red LED, Radio Shack 276-041 or equal
 S1—SPST toggle or push-on/push-off switch
 S2—SPST momentary pushbutton switch
 J1—shorting-type phone jack, see text
 BATT1-BATT4—size-C or size-D dry batteries, see text
 Misc:
 (14) 14-pin wire-wrap-type DIP sockets; (2) 16-pin DIP wire-wrap sockets; battery holder; perforated board; 22-gauge and 30-gauge wire; pressed board or *Masonite*, etc.

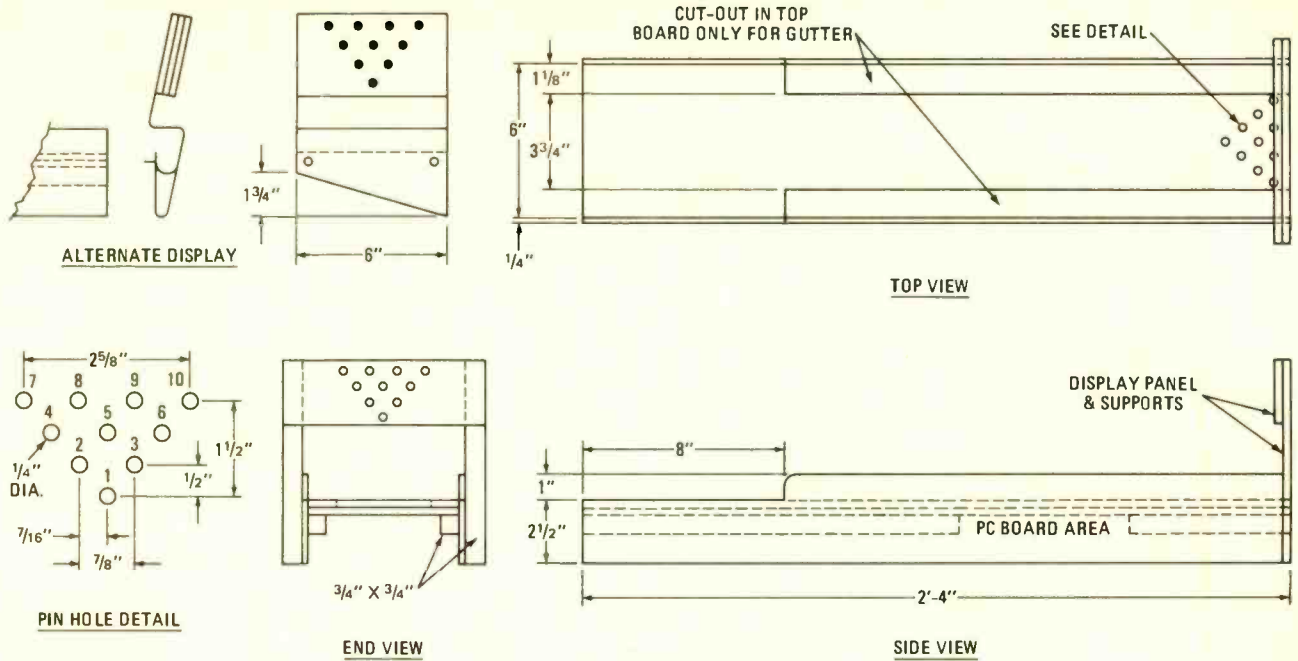

NOTE:
 LED1-LED10 MOUNT IN PIN POSITIONS 1-10 RESPECTIVELY ON DISPLAY PANEL
 PHOTOTRANSISTOR Q1 MOUNTS IN POSITION 1, Q2-P2, Q3-P3, Q4-P4, Q5-P6, Q6-P7, Q7-P10 ON ALLEY SURFACE
FIG. 6—SUGGESTED DIMENSIONS for the bowling alley. Pin hole spacings are for "ball" the size of a quarter. Alternate display mount has sloping "ball" return.

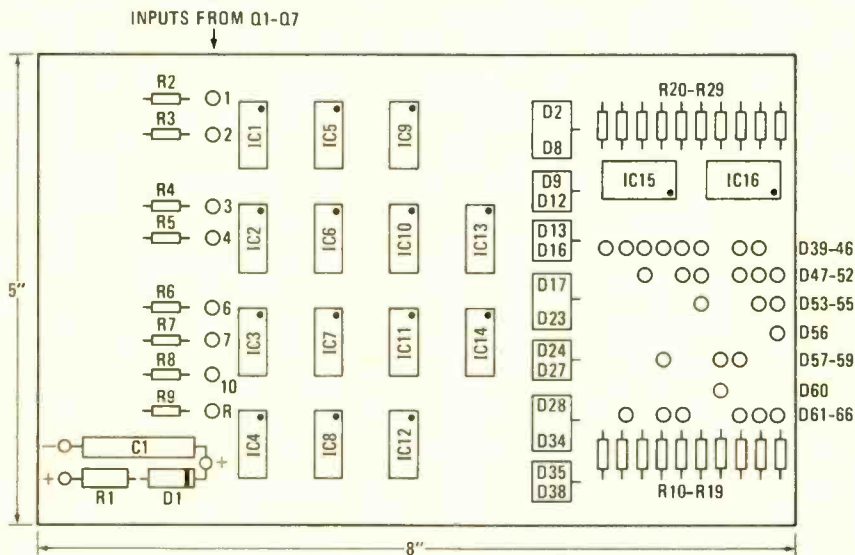

FIG. 7—HOW PARTS ARE POSITIONED on the circuit board. The transistors are cemented top-side-down so the pins are convenient for point-to-point wiring.

Q1-Q7, carefully bend the other two leads as shown in Fig. 9, and insert them into the two small holes. Press down gently, making sure each transistor is slightly below the playing surface. Now, wire all the emitters in parallel and hook a separate lead to each collector. Leave these eight wires long enough so that they reach the eventual locations of R2-R8.

Constructing the display panel

The size of the display board is determined by the mounting method chosen. The simplest type of mounting is to attach the display panel to two vertical posts attached to the side frame pieces near the far end of the alley. In this case, the width of the panel will be the overall width of the alley plus the thicknesses of the vertical mounting posts (a 1/4-inch

width is recommended). The actual display area is composed of two pieces of 1/4-inch or 3/16-inch particle board or Masonite. Drill two small holes (a maximum of 1/16 inch) at the location of each LED in the front piece, then paint the panel flat black. Insert the LED leads, hold the LED's flush and carefully bend the leads flat on the back of the panel. Wire all the anodes in parallel with a piece of 22-gauge hookup wire that is long enough to reach from the display to the circuit board. Then, connect a similar length of 30-gauge Kynar wire to each of the cathodes. Group all the wires together at a bottom corner of the panel, and bolt or screw the back-panel cover in place. This will both hide the wires and hold the LED's in place. Now, carefully strip the necessary length of outer insulation off a

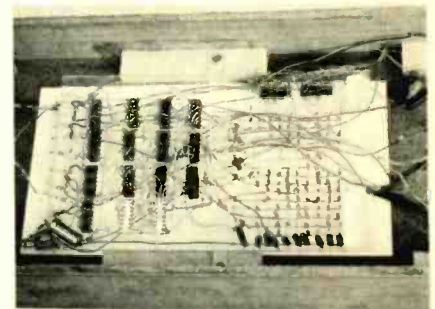

INTERIOR PHOTO showing circuit board of one version of the game. A PC board was not used because of circuit complexity.

piece of coax or other available wire of the proper size, and use it as a sheath for the eleven leads between the panel and the circuit board.

For a more professional look, drill the proper size holes in a piece of clear acrylic plastic and add it to the front of the panel. It will enhance the display brightness and give a finished appearance. I formed a convoluted shape out of clear plastic to form both a front panel and a sloping ball return.

Installation and testing

First, insert all the IC's into their proper sockets, observing polarity and CMOS-handling procedures. Then, screw the corners of the PC board to the mounting blocks and install power jack J1 and switches S1 and S2. If batteries are used, mount the battery holder. Finally, connect the display, power and switch leads. Be very careful to observe polarity at jack J1 and the battery holder. Unless the display wires are color-coded or tagged, they will have to be sorted out one

continued on page 106

WHAT'S NEW IN RECHARGEABLE BATTERIES

If we wanted rechargeable batteries to supply power to electronic equipment, we generally selected a NiCad or special alkaline type. Now, we can choose Lithium too

WALTER SALM

IF YOU USE BATTERIES (AND WHO doesn't), you're probably painfully aware of some of their limitations. Primary (nonrechargeable) batteries fill a definite need in our lives, but they have the distressing habit of becoming exhausted just when you need them the most.

The obvious answer to this has traditionally been the secondary (rechargeable) battery, and where electronic equipment is concerned, nickel-cadmium (Ni-Cad) has been king for the last 10 to 15 years. But there are many forms of rechargeable batteries with specifications that vary widely. In addition to nickel-cadmium, there is the lead-acid type which is now being trimmed down from its large automobile size to small sealed units that are supposed to compete with nickel-cadmium. The sealed lead-acid type uses a sulfuric acid gel for its electrolyte, making it about as dry as other "dry" secondary batteries. It has the big advantage of a lower cost per watt-hour—less than 1/4 as much as the nickel-cadmium type.

But the sealed lead-acid cell just hasn't caught on all that well with consumers. For one thing, the cell's nominal open-circuit potential of 2.0 volts means that it has little compatibility with the more traditional types of batteries used in consumer goods, such as appliances, radios, calculators and other devices. Remember, these devices were mainly designed to work with primary batteries that typically have a 1.5-volt open-circuit potential. The nickel-cadmium battery has been fairly interchangeable with them because of its 1.35 to 1.4-volt open-circuit rating. The slight difference in voltage is usually more than made up for by the NiCad's

higher current discharge rate.

A closer look at the nickel-cadmium cell shows that it has a lot of built-in safeguards—and some important variables. When most secondary batteries recharge, a certain amount of waste-product gas is produced by the charging process. The lead-acid batteries used in the family chariot vent this gas through the small holes in the water filler plugs. Periodically, this type of battery must have water added to offset normal evaporation and water lost during the recharging process.

In the sealed nickel-cadmium battery, the gas produced is oxygen, which is handled by two techniques: providing enough internal air expansion space to accommodate this gas within the cell until it goes back into solution in the electrolyte during discharge; and by providing chemicals that would combine with and absorb excess oxygen to prevent pressure buildup. Generally though, as used by consumers, nickel-cadmium batteries do not vent gas when used with chargers recommended by the battery manufacturer.

Most people think nothing of leaving a set of batteries plugged into the charger long beyond their recommended maxi-

mum charging period. It's quite familiar to notice the razor sitting on the shelf with red light still glowing a full 24 hours after it should have been unplugged. "Ohmygosh, how long has that been charging?" is the usual reaction.

Since one of the biggest abuses of NiCad's is overcharging (and overdischarging), most manufacturers now provide some kind of exhaust vent to prevent the ultimate catastrophe—an explosion or rupture due to overcharging, an event that rarely happens with consumer batteries but can occur in heavy-use industrial and commercial applications. There are basically two types of such vents—one-shot deals that effectively take the battery out of useful service, but prevent the explosion; and resealable vents that relieve pressure but maintain the battery's airtight integrity.

The secret of the resealable vent is that it opens only momentarily and then only when the internal gas pressure gets so high that the battery is in danger of rupturing. The vent opens, a puff of charging gas (oxygen) escapes, and the vent closes and reseals automatically. Actually, this vent can open and reseal many times during a heavy overcharge cycle,

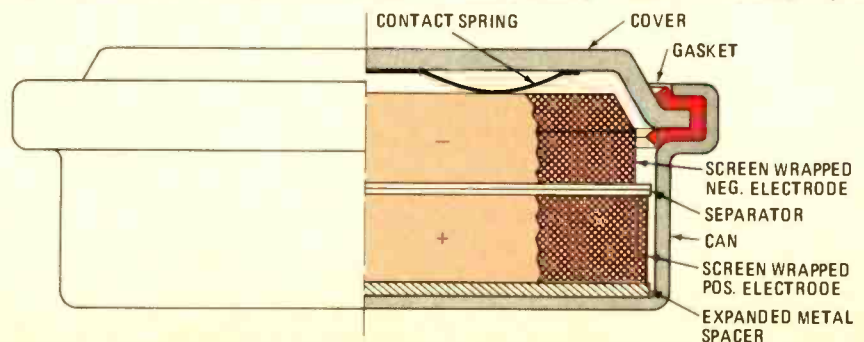

INTERNAL CONSTRUCTION of a sealed nickel-cadmium button cell.

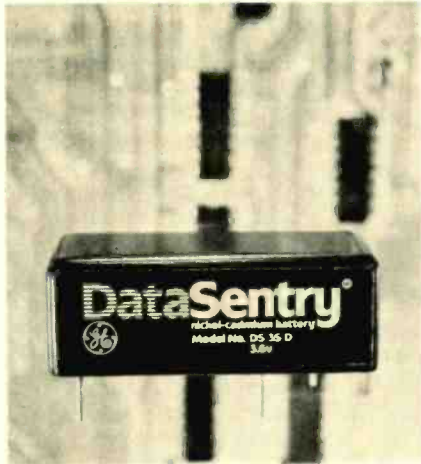

NI-CAD IN A DIP from General Electric mounts directly on PC boards to provide standby power for logic circuits.

and its presence greatly extends the life of the battery.

The non-resealable vents, while they avoid possible battery rupture, stay open once they break their seal, and the battery's electrolyte then proceeds to dry out fairly quickly.

The resealable vent is especially important in batteries used with quick-charge systems of 15 minutes or so.

Lead-acid in new dress

While it's fairly common to compare other rechargeable batteries with the venerable open-vented wet automotive lead-acid type, this old-time combination of materials has taken on new dress in recent years. The dry, sealed lead-acid battery has been on the scene for a couple of years now, and is gaining ground in many areas. Unfortunately, it still hasn't been able to displace the nickel-cadmium battery yet in its many consumer power applications.

In its basic form, the dry lead-acid battery consists of two strips of lead separated by a porous glass-fiber strip. This sandwich is wound up into a cylindrical form and then baked to harden the lead paste. Once in the case, a very tiny amount of sulfuric acid is squirted in to become the electrolyte, and the whole thing is sealed up. There's no venting needed (except for instances of battery abuse), since the battery chemistry uses up free oxygen as soon as it forms during charging, and the battery will not overcharge.

Weight is somewhat of a problem when comparisons are made with NiCad types, but there is even more of an obstacle—the 2.0 volt open-circuit cell potential obviates any possible direct replacement use for conventional carbon-zinc or man-

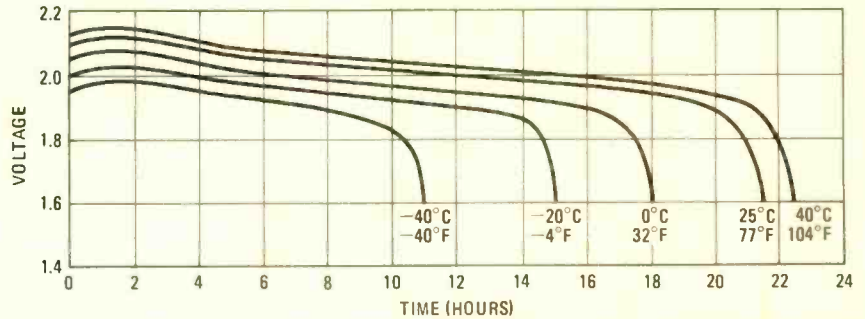

DISCHARGE CURVE for a sealed lead-acid 2.5 amp-hour D-size cell with a 125-mA current drain.

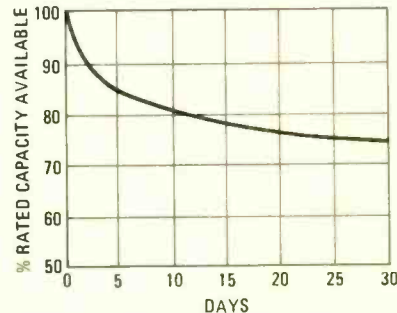

SELF-DISCHARGE CURVE of sealed nickel-cadmium cells in dry air.

ganese-alkaline types. Manufacturers of this type of battery instead feel that energy-consuming appliances should be designed around the battery, instead of the other way around. And there is certainly some validity in this viewpoint.

The discharge rate of both sealed-lead-acid batteries and nickel-cadmiums can be tailored to meet deep-discharge needs

in certain applications. A favorite place for such batteries today is electric-start lawnmowers, motorcycles and other devices ordinarily started by handcranking.

Lead-acid batteries have also appeared as rechargeable lantern batteries (they're 6 volts, so the 2-volt nominal doesn't present a design problem) and in certain kinds of high-consumption power tools and appliances that are more conveniently used in a cordless version.

Lead-acid battery manufacturers state that these units can be recharged at least 200 times, and deliver full rated power each time. Full discharge doesn't shorten the battery life as it can do with some other types, and the battery doesn't leak off the charge as rapidly as NiCad's or conventional wet lead-acid batteries. NiCad's, on the other hand, are often guaranteed for at least 500 charge/discharge cycles, but can hold a full charge only for a week or so before leaking it off. As with

POSITIVE AND NEGATIVE PLATES SPIRALLY-WOUND TO YIELD HIGH DISCHARGE CAPACITY, EVEN AT HIGH RATES.

HIGHLY RETENTIVE SEPARATOR THAT RETAINS ESSENTIALLY ALL OF THE ELECTROLYTE.

PURE LEAD GRIDS GIVE EXCELLENT CORROSION RESISTANCE AND LOW INTERNAL IMPEDANCE.

SAFETY VENT THAT ALLOWS FOR VERY ABUSIVE OVERCHARGE OR CHARGER FAILURE WITHOUT CELL RUPTURE.

ENCLOSED IN A RUGGED METAL CAN NO ACID OR ACID VAPOR IS VENTED FROM THE CELL. GAS IS RECOMBINED DIRECTLY WITH THE PLATE MATERIALS AT UP TO THE C/3 RATE OF OVERCHARGE. THE METAL CAN PROTECTS THE CELL FROM PHYSICAL DAMAGE.

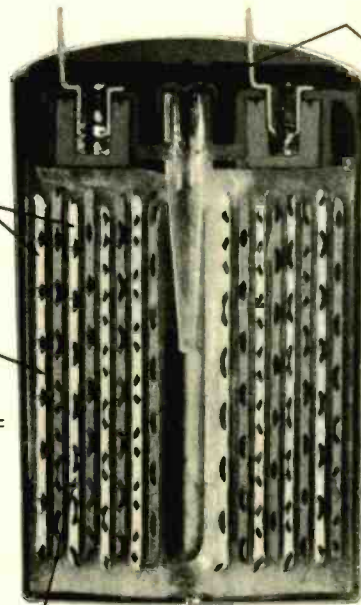

INTERNAL CONSTRUCTION of a typical sealed lead-acid cell.

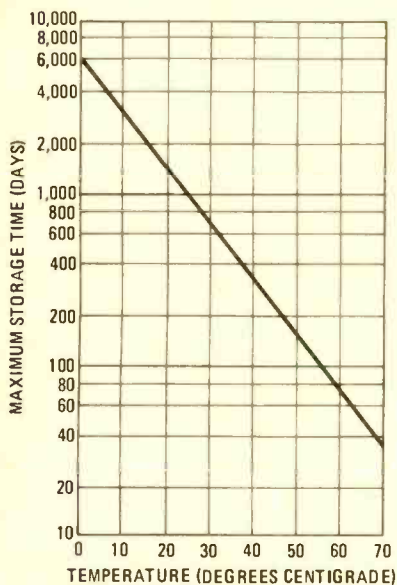

STORAGE TIME vs. temperature for sealed lead-acid cells.

anything, you pay your money and you take your choice.

Lithium to the rescue

Remember the big splash over lithium primary batteries a couple of years ago? These batteries were going to be the power source of the future—they had such fantastic energy density. But as with many new technological developments, they had their design problems, which have been pretty much cleaned up by now.

Lithium's prodigious energy-storing properties have now come to the rechargeable battery. Two companies—Bell Laboratories and Exxon Research and Engineering Co.—have developed lithium secondary battery technologies that could well be the beginning of a minor revolution in energy sources. Bell's battery is called lithium-vanadium disulfide, while Exxon's is lithium-titanium disulfide. They both use certain special properties of metal-disulfide combinations to make the batteries work.

These materials belong to a class known as "layered compounds" and the compounds are typically only three mole-

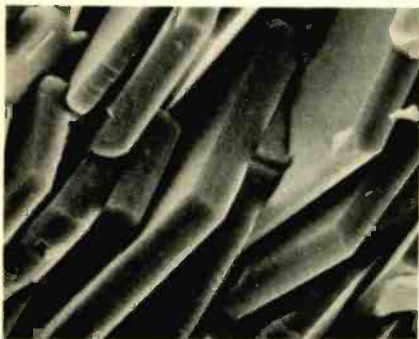

TITANIUM DISULFIDE compound used in lithium cells produced by the Exxon Engineering and Research Company. This view of the compound with a X1000 magnification shows the layering effect. The between the layers is filled with lithium.

cules thick—two molecular thicknesses of sulfur bonded with a layer of metal molecules in between, sandwich-fashion. The next layer consists of another sulfur-metal-sulfur bond and so on.

These layers are loosely bonded together like the pages in a book—with free space in between. A familiar layered material that comes to mind is mica, whose "pages" can be peeled apart rather easily.

In these layered compounds, the space between the layers is filled with lithium (full discharge state). When the battery is charged, the lithium migrates out from between the layers and is plated out as lithium metal. There is no reason for the lithium to move back between the layers until current is drawn from the battery. Thus, the battery retains its full charge.

Since the charge/discharge cycle doesn't involve any kind of chemical reaction, just a migration of lithium ions from one free space to another, there's no opportunity for any kind of chemical deterioration to occur. One scientist at Bell Labs described it as something like a sponge taking up water. The sponge may increase slightly in volume when all the spaces are filled, but it hasn't changed at all. The lithium ion migration into the space between layers acts much the same way.

Plastic separator

A further difference between the Bell and Exxon batteries is the plastic sheet separator used by Exxon. Here, the layered titanium disulfide is separated from a layer of metallic lithium by a porous plastic film. Once again, lithium ions migrate through the electrolyte mix, in this case a solution that's as dry as the paste in most "dry" batteries. Unlike the Bell battery, in which the layered compound is pressed or molded into a sponge-like shape, Exxon physically layers the material on a substrate, covers it with the plastic sheet, then covers it with a layer of lithium.

The other big difference between the two companies' approaches: Bell is licensing the manufacturing to other companies instead of producing batteries itself; Exxon is already in pilot production in a spanking-new plant and expects to have full-scale production underway soon. The new manufacturing subsidiary is part of Exxon Enterprises, Inc.

The new lithium rechargeables have several important features:

- Once charged, they can be stored indefinitely without leaking off any of the charge.
- No matter how many times the battery is cycled through charge/discharge, there is no chemical deterioration.
- Energy density is significantly higher than for other battery types—typically about two to five times as much as for comparable size nickel-cadmium batteries.

But that unlimited lifetime does have some qualifications. As one Exxon scientist put it, "Deep charging and discharging could have some adverse effects on battery lifetime. Actually, you can wreck any battery if you abuse it badly enough."

The frosting on the cake is a very practical application in a mind-blowing desk ornament proudly displayed by Exxon officials. Sealed into an acrylic plastic paperweight is an LCD digital watch movement, a lithium cell about the same diameter as the watch movement, and a tiny string of solar cells. The solar cells trickle-charge the battery, which keeps the watch running—indefinitely. Exxon believes that new products will be tailored to use these new batteries wired in permanently—just like so many transistors, resistors and capacitors. Since the battery will probably outlast whatever device it's powering, this doesn't sound like such a bad idea.

The one hitch is that the lithium rechargeables aren't directly interchangeable with batteries that have a nominal voltage of 1.5 volts; they can be designed for full-charge potential ranging from 2.1 to 2.4 volts per cell. The LCD watch desk ornament uses a tiny voltage-dropping resistor as a regulator to suit the voltage to existing watch circuits. But such "regulators" won't be needed with many products since they'll be designed with the lithium batteries in mind.

On the horizon, we'll probably soon see a whole new class of devices with permanent batteries. Overnight charging will become normal, while fast-charge systems will also undoubtedly be developed. It will be a boon for the person who can't afford to have a single day of downtime on his timepiece. It will be a godsend for the hearing-impaired whose hearing aids eat up expensive mercury batteries at a prodigious clip. The money saved on batteries will pay for a second hearing aid, so while one is being worn, the other can be hooked up to the charger.

The timetable is still a little fuzzy. But Exxon feels that the first product to feature its battery—probably a timepiece in the over-\$100 range—could be ready for the market in a year or less. From there, the sky's the limit for the new "Forever Battery."

R-E

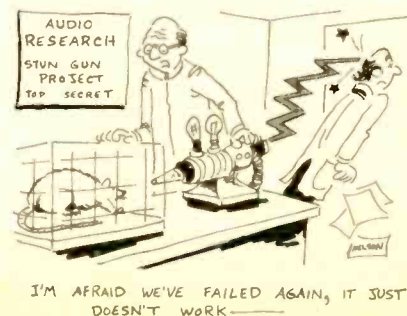

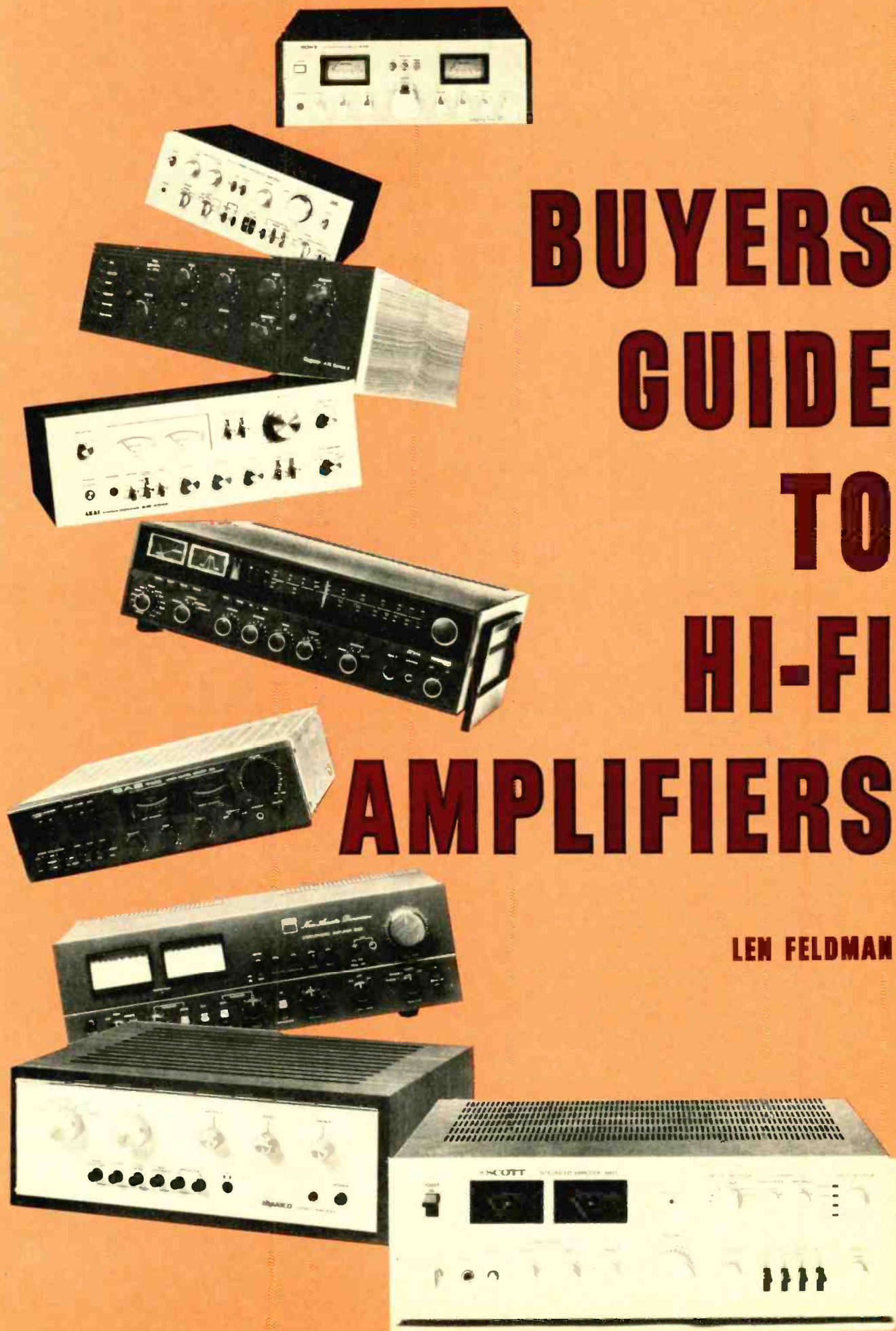

BUYERS GUIDE TO HI-FI AMPLIFIERS

LEN FELDMAN

How To Select The **BEST** Amplifier For Your Hi-Fi

Although the fidelity and response of an audio system can be no better than that of its poorest component, the amplifier may be the very heart of the hi-fi setup. Use this guide to amplifier selection.

LEN FELDMAN
CONTRIBUTING HI-FI EDITOR

THE AMPLIFIER OF A COMPONENT HIGH-FIDELITY SYSTEM may well be thought of as the "heart" of that system. All program source signals—whether they are from AM or FM broadcasts, phonograph records, tapes or TV—all pass through the amplifier before they are applied to the loudspeakers (or stereo headphones) for conversion back into audible sound.

When this article refers to a high-fidelity amplifier, we mean all the required amplification circuits, from the so-called preamplifier stages right on through to the power-output stages. In terms of high fidelity components, therefore, we might find the audio amplifier sections of a system contained in a single unit (a so-called integrated amplifier containing a preamplifier and a power amplifier); a two-unit system (a separate preamplifier/control unit and a so-called "basic" power amplifier); or even a subsection of a more all-encompassing component known as a stereo receiver (which, in addition to containing amplifier elements, also contains the FM tuner circuitry). Which of these three amplifier alternatives you choose for your system will depend upon your budget (usually, separate components end up costing more than an all-in-one receiver), the amount of space you have available for your components, and the degree of control flexibility and number of operating features you require.

Receivers, because of their compact size, generally offer a lower power output and fewer switches and controls than separate components. However, in recent years there has been a distinct tendency on the part of receiver manufacturers to offer higher and higher power outputs (the latest "record" set by one manufacturer is 250 watts-per-channel) as well as many, if not all, of the controls and switches normally found on separate components.

No matter which form of amplifier you elect to purchase, its performance specifications and the operating features you should be aware of are common to all types and can be discussed in similar terms. So, as we examine those specifications and features, we will use the

term "amplifier" regardless of whether the unit is an all-in-one receiver or a separate component.

Phono preamplifier and equalizer

Signals delivered by such program sources as an FM or AM tuner or a tape deck are generally much greater in amplitude than those produced by the tiny phono pickup, or cartridge, mounted in the pickup arm of your record changer or turntable. The latter signals may have an amplitude of just a few millivolts. Accordingly, the phono signals must be amplified to a greater extent than the other high-level signals. The phono preamplifier section of an amplifier performs this task, raising the signal-amplitude level produced by the phono cartridge from a couple of millivolts to perhaps one-half volt or more.

The phono preamplifier section performs another important task—that of equalization. Modern phonograph discs are recorded with anything but a flat frequency response. Low bass frequencies are deliberately attenuated, while high treble frequencies are boosted or pre-emphasized. These frequency-response modifications are made to accommodate a greater amount of music per-disc-side and to improve the signal-to-noise ratio of the resulting disc by decreasing the audible surface noise heard during playback. But, to play back a record properly, all frequencies must be restored to their correct relative intensities. This is done by introducing the converse frequency-response characteristic in the preamplifier section. The process is known as RIAA equalization (RIAA stands for *Record Industry Association of America*), and the same response curve is standard throughout the world. The RIAA playback response curve shown in Fig. 1 is the exact converse of the RIAA recording characteristic, so that the net effect of this two-part process is to restore flat response to the music we hear from phonograph records.

This response curve must be adhered to as accurately as possible, and, in quoting the frequency-response curve of a given preamplifier section, manufacturers generally use

the following statement: "Frequency response, Phono: RIAA \pm 'so-many' dB." The lower the dB value, the more precise the equalization. Thus, "RIAA \pm 0.5 dB" represents a more accurate equalization (and, hence, a flatter playback response) than "RIAA \pm 1.5 dB."

Another phono-input specification is the input sensitivity. This specification, rather than being a measure of the quality of the preamplifier, is given to enable you to properly match the phonograph cartridge to the preamplifier. Stated in millivolts (mV), the specification indicates how much of a signal must be fed to the preamplifier's phono inputs so that, with the volume control turned all the way up, the preamplifier delivers its rated output voltage (or, in the case of an integrated amplifier or receiver, delivers its full rated power output).

Obviously, if a preamplifier requires a signal input of 4 mV and a cartridge is connected to it that nominally delivers a signal of only 1 or 2 mV when tracing record grooves, the cartridge will have difficulty driving the amplifier or preamplifier to its rated output. Most state-of-the-art preamplifiers intended for use with magnetic cartridges (the type preferred for high-fidelity use) have input sensitivities ranging from 2 to 3 mV, a value that closely matches the typical output of most phono cartridges.

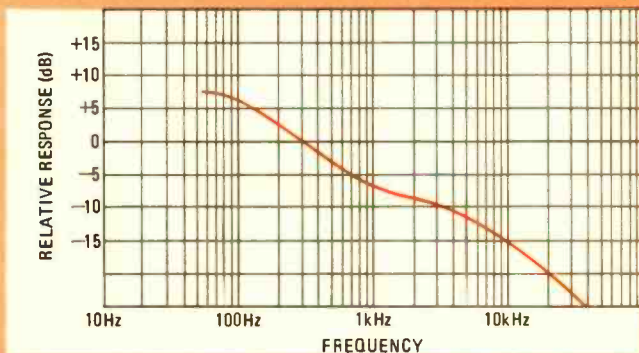

FIG. 1—RIAA PLAYBACK CURVE is the converse of the curve used during the recording process.

Recently, the Institute of High Fidelity (IHF), an American-based trade organization of high-fidelity component manufacturers, devised a new set of amplifier measurement standards. The new Standards (IHF-A-202, 1978) are an attempt to make amplifier measurement more uniform among manufacturers, so that when prospective purchasers compare specifications they can be sure that all the manufacturers' measurements are based upon the same reference points and can therefore be meaningfully compared.

One of the changes incorporated in these Standards concerns the measurement of input sensitivity of preamplifiers and amplifiers. The IHF felt that referencing phono-input sensitivity to the full rated output of an amplifier was not the best way to arrive at this specification. The reason will be clear if you consider the following example:

Suppose there are two amplifiers, one having a power-output rating of 10 watts-per-channel, the other with a power-output rating of 100 watts-per-channel. Suppose also that each manufacturer rates the phono sensitivity of these amplifiers as 2.0 mV (the voltage needed to drive the amplifier to its rated output). Clearly, the 100-watt-per-channel amplifier will *sound* much louder when driven with a 2-mV signal than the 10-watt-per-channel amplifier.

The IHF decided that it would be better to specify phono-input sensitivity (as well as the input sensitivity of other amplifier inputs) with reference to a constant, fixed *output* level of 1 watt, regardless of the amplifier's power rating.

Under these test conditions, the "new IHF" phono sensitivity of the 10-watt-per-channel amplifier would become 0.63 mV, while the phono sensitivity of the 100-watt-per-channel amplifier would be 0.20 mV. These results clearly indicate that if the *same* level of phono signal is applied to each amplifier, the 100-watt-per-channel amplifier will sound much louder, which is indeed the actual case.

Another important specification related to the preamplifier's phono input is known as "phono overload" or maximum phono-input level. Also stated in millivolts, this specification gives the maximum phono-input signal level that can be applied to the preamplifier before it produces audible distortion.

While average music signals imbedded in record grooves may cause a phono cartridge to produce a 2- or 3-mV signal, modern records have a great dynamic range and, during loud musical passages, cartridges may deliver much more voltage. Therefore, it is important that the preamplifier be able to handle higher signal levels without introducing distortion.

Phono S/N ratios

All electronic circuits generate some noise of their own. If the noise is very low compared with the signal being processed by the circuit, when the signal is finally reproduced with its added noise, the noise may be inaudible since it is so much lower in amplitude than the desired audio signal. In the case of very small phono-cartridge signals, the preamplifier stages must generate far less internal noise if that noise is to be inaudible after the extra phono-signal amplification. An all-important specification relating to the phono section is, therefore, the signal-to-noise (S/N) ratio.

Unfortunately, because not all manufacturers quote the S/N ratio in the same way, S/N specifications vary and cannot be easily compared with each other. The most conservative phono S/N specification references the residual hum and noise to the *rated* input sensitivity—i.e., how much lower the amplified noise and hum is compared with the amplified 2.0- or 3.0-mV phono-input signal.

On the other hand, some manufacturers refer the S/N figure to 10-mV input (a voltage value rarely produced by a cartridge tracing standard test record grooves). Clearly, the same amount of noise will be further removed or lower with respect to a 10-mV amplified phono signal than with a 2-mV or 3-mV signal, and the resulting S/N figure, quoted in dB (the higher the better), comes out anywhere from 10 dB to 14 dB higher than would be the case if it were referenced to the lower input signal level.

Often, certain weighting curves are inserted during phono hum-and-noise measurements. These curves tend to downplay the "hum" components of the resulting noise output, as well as the higher hiss frequencies of noise, on the theory that human hearing is less susceptible to these extreme frequencies than to middle-range musical frequencies. True as this theory may be, it nevertheless leads to still higher, or better, S/N figures when applied to amplifiers. Manufacturers who use this measurement technique will, at least, say so in quoting the results. Thus, the notation, "S/N, Phono (IHF "A" Weighted),"

means that such weighting networks have been used in making the measurement, and these weighted measurements should not be compared with unweighted measurements quoted for another product.

The new IHF Amplifier Measurement Standard addresses the problem of the many ways in which amplifier manufacturers have been specifying S/N ratio (and the attendant confusion this creates in the mind of the prospective consumer). The audio engineers who devised and wrote the new standard reasoned that, in the first place, users are not likely to listen to amplifiers with the volume control turned all the way up (the setting of this control normally used to measure S/N ratios). A standard phono cartridge output level of 5 mV was set as the reference level against which signal-to-noise should be measured for all amplifiers.

The procedure, therefore, is to apply a fixed 5-mV signal to the phono inputs and to reduce the volume control on the amplifier until the *output* at the speaker terminals is equal to 1 watt (0.5 volt for separate preamplifiers that do not include power-amplifier circuitry). Next, the 5-mV signal is removed, a dummy load equivalent to the impedance of a phono cartridge is inserted into the phono-input jacks, and the noise level is measured on a meter and expressed in dB below the new input and output reference levels. The "A" weighting measurement is also used in the new technique.

There is no direct way to correlate the new IHF S/N measurements with older methods. On the one hand, the 5-mV input level will tend to make the dB values look higher, compared with readings obtained when lower input levels (such as 2 mV) were used, but the values will be lower if a manufacturer had previously used a 10-mV input level as a reference signal. On the other hand, the 1-watt *output* reference to which the volume control must now be set tends to make the dB values *lower*. The use of an "A" weighting network (if none was used in earlier S/N measurements) further complicates the relationship between the old and new readings. As soon as all manufacturers begin to use this new measurement technique, however, comparisons of the S/N ratio between competing amplifiers will be more meaningful in terms of actual perceived noise and hum; the higher dB values will, as usual, mean a *better* specification. During the transition period, some manufacturers may continue to quote their old S/N ratios as well as the new IHF measurements.

The final specification usually associated with the phono-input section of an amplifier is the input impedance. Usually, the input impedance will be 47,000 ohms or 50,000 ohms, a figure that is most nearly ideal for most phono cartridges. Some preamplifier sections may be equipped with a switch selector that permits you to choose other input impedances to match the specific cartridge requirements, such as those for playing quadraphonic (CD-4) records, which generally perform optimally with a 100,000-ohm impedance.

Amplifier control section

Figure 2 is a block diagram that shows the various sections of a complete audio amplifier. Earlier this article discussed the phono-preamplifier section. Only a single stereo amplifier channel is shown in Fig. 2, since the opposite channel of the stereo pair is identical. Note that connection points for high-level tuner or tape signals bypass the preamplifier section and go directly to the

program selector switch. The signal selected by this switch is then fed to one or more tape monitor circuits that are nothing more than switchable circuit-interruption points in the signal chain.

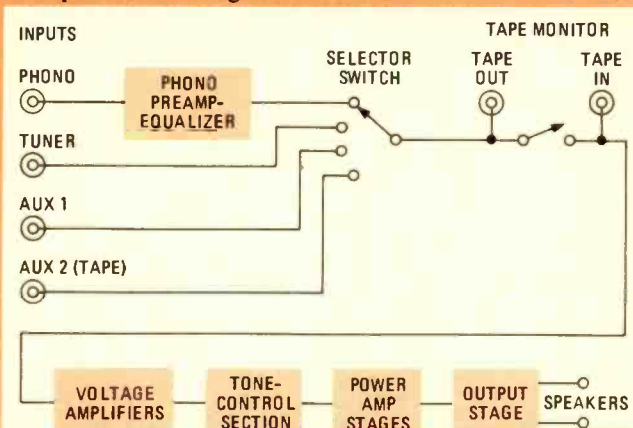

FIG. 2—BLOCK DIAGRAM of an amplifier.

Input and output jacks were originally devised as a connection point for tape decks—by connecting the amplifier's tape-out jack to the tape recorder input, and the tape-in or tape-play jack to the recorder's output, you can monitor the recorded results from three-headed tape machines a fraction of a second after the recording itself has been made. These input/output jacks are also useful as connection points for such audio accessories as graphic equalizers (they offer better tone control than more common bass and treble controls); noise reducers (Dolby decoders, or those using different noise-reduction designs); dynamic range expanders (they process music signals to restore an otherwise compressed dynamic music range); and even four-channel decoders. If you plan to expand your high-fidelity system to include a tape recorder and any of the above accessories, you should look for at least two separate tape-monitoring circuits on the amplifier you're considering.

Amplifier power

The most important question you will face in choosing an appropriate audio amplifier for your hi-fi system is: how much power output should the amplifier be able to produce? Much has been written about power requirements for audio systems, but here is a general guideline:

The louder you like your music, the more power you need. The larger the listening room, the greater the power requirement. The lower the efficiency of the speaker you select, the more power needed from the amplifier. The greatest variable of all is speaker efficiency. One type of speaker may require ten times as much power as another to deliver the same apparent loudness level. In fact, it is a good idea to choose speakers before any other component in your system. Then you can audition different amplifiers (or receivers) by hooking them up to your previously selected speakers to determine if the amplifier has sufficient power reserve to produce undistorted sound at your highest preferred listening levels.

Prior to November, 1974, many amplifier manufacturers specified the power-output ratings of their products in a variety of different ways, leading to all sorts of confusion regarding amplifier power ratings that was even worse than that associated with signal-to-noise ratios. After November, 1974, all amplifier manufacturers were required to state power ratings in very specific terms, as

AMPLIFIER CLASSES

AS YOU READ THROUGH THE BROCHURES SUPPLIED by various amplifier manufacturers you will probably come across terms such as "Class A," "Class AB," "Class B," etc. These terms all refer to the type of circuits used in the final power-output stages of audio amplifiers. There are many ways in which to arrange an amplifier's output stages, and these are identified by the "Class" notations. While it is possible to design good-sounding amplifiers in all classes, let's examine the difference between them.

In a Class-A amplifier, the transistor or transistors that supply power to the speaker load continuously conduct current, and that current value is essentially constant. In the absence of an audio signal, all the current (and power) is dissipated within the transistors themselves. When a signal appears, part of the power developed by the output stage is transferred to the speaker load. This arrangement is, therefore, highly inefficient, in that the same amount of power is drawn from the amplifier's power supply regardless of whether the amplifier is producing its maximum rated power, no power at all, or anything in between. Class-A amplifiers (what few exist these days) are therefore generally noted for their lower power-output ratings, and require unusually large heat-sink devices to dissipate the heat generated by the always fully on transistors. Class-A amplifiers are, however, capable of producing extremely low-distortion sound and are favored by those listeners to whom the unusually large energy consumption is of secondary importance.

A Class-B amplifier requires at least two output transistors. Each transistor is designed to amplify one-half of the alternating waveforms that constitute an audio signal. One transistor amplifies the positive-going wave, while the

other transistor amplifies the negative-going half-cycle of each alternation. In the absence of all audio input signals, each transistor draws almost no current, and a Class-B amplifier, in the absence of input signals, runs extremely cool. As signal levels increase, current drawn from the power supply also increases until maximum power-output levels are reached. Thus, a Class-B amplifier is much more efficient than a Class-A unit. Class-B efficiency (at full power output) can reach as high as 65% or so (it is less than that at lower power levels), as opposed to the typically low 20% to 25% for a Class-A design.

While Class-B amplifiers can be designed to produce equally low distortion, special care must be taken in their design to make sure that no discontinuities in output take place as the signal is switched from one transistor to the other. Failure to observe proper design techniques can result in "notch distortion," or "crossover distortion," which is particularly annoying at low listening levels.

Class-C amplifiers are not normally used in audio amplifier circuits, but are reserved for radio receivers and transmitters. A Class-C amplifier conducts for less than one-half of each cycle, and depends upon the flywheel action of an associated resonant circuit to fill in the missing portion of the waveform. A Class-C amplifier is therefore practical to use where the same single frequency is to be amplified continuously, but is impractical for amplifying constantly varying complex audio signals.

The so-called Class-D amplifier is also known as a "switching amplifier," or "pulse-width modulation" amplifier. One or two manufacturers offer limited quantities of Class-D amplifiers, and a great deal of experimentation with this type of amplifier contin-

ues. In a Class-D amplifier, a very high-frequency series of pulses are modulated in their width by the audio signal. The output stages need to conduct for a short interval only to amplify the tips of these pulses, and when they do conduct, they are highly efficient—conducting as much as 90% to 95%. The high-frequency pulses associated with Class-D amplifiers (500 kHz or more) present special problems in the transistor switching speed and suitable transistor availability.

The recently developed Class-G amplifier uses a minimum of two pairs of output transistors. One pair is powered by a lower voltage supply than the other. When signal levels are relatively low, only the low-powered pair of transistors does the amplifying. When signals exceed the low-voltage supply amplitude, the other transistor pair, which operates from the higher voltage supply, takes over, while the first pair is simultaneously turned off. In this way, each pair of transistors is always operating over its most efficient range, and overall amplifier efficiency is greater with a Class-B design. Thus, less massive heat sinks are needed for the output transistors, and the complete amplifier or receiver is lighter in weight.

Somewhat similar to Class-G operation is the new and tentatively labeled Class-H amplifier. Only one set of output transistors is used, but these transistors are connected to two different power-supply voltages. The lower voltage powers the output devices for low-level signals, while the higher voltage takes over when the input signal amplitudes exceed the limits of the low-voltage supply. As in Class-G, this approach results in a more efficient use of the output transistors, and the audio signals themselves do not have to be switched from one device to another during the process.

dictated by a Federal Trade Commission rule. Even this standardized rating system, however, leads to certain ambiguities that should be clarified when comparing the power ratings of competing products.

The FCC rule says that a manufacturer must state the amplifier's ability to deliver *continuous* power with both channels operating. The stated power rating must be referenced to a given speaker impedance (since most amplifiers generally deliver higher power to 4-ohm speakers than to 8-ohm speakers). Furthermore, the manufacturer must state over what frequency range the amplifier can deliver its full rated power (since most amplifiers reproduce mid-frequencies somewhat better than extremely low bass or high treble tones). Finally, a statement must be made regarding the distortion level that the amplifier will produce at any power level up to its rated output level.

Thus, a typical power-output specification might read: "Power Output: 50 watts minimum continuous power into 8-ohm loads, at any frequency from 20 Hz to 20,000 Hz, with no more than 0.5% total harmonic distortion." Since the rule simply states that all these facts must be given (but does not specify minimum acceptable numbers), some degree of care is still required. For example, suppose amplifier A has a power rating of 100 watts-per-channel, 8-ohm loads, from 20 Hz to 20 kHz at no more than 1.0% distortion, while amplifier B is rated at the same 100 watts-per-channel, 8-ohm loads, 20 Hz to 20 kHz at no more than 0.3% distortion. Clearly, amplifier B is the better of the two. Or, suppose amplifier A is rated at 100 watts-per-channel, 8-ohm loads, from 20 Hz to 20 kHz, with no more than 0.2% distortion; amplifier B also carries a 100-watt rating, 8-ohm loads, from 40 Hz to 15 kHz at no more than 0.2% distortion. In this case,

amplifier A is superior to amplifier B.

We have been using the word "distortion" without truly defining it. In fact, there are many forms of distortion that an amplifier can generate. Distortion is defined as any difference between the nature and composition of the signal input to the amplifier and the resulting output signal. The most common distortion is harmonic distortion. If, for example, a 400-Hz pure tone is fed to an amplifier, the output signal should contain an equally pure 400-Hz tone and nothing else. If multiples of that frequency show up in the output signal, such as 800 Hz, 1,200 Hz, 1,600 Hz, etc., the signal is said to contain harmonic distortion. While musical instruments produce complex harmonics or overtones, all of which should be faithfully reproduced by an amplifier, the amplifier should not generate its own harmonics, for these would change the overall musical timbre or coloration. Figures 3 and 4 show examples of amplifier-generated harmonic distortion. The upper trace of Fig. 3 shows that a single frequency or tone is reproduced by an amplifier with little or no distortion. The lower trace is a highly magnified representation of *only* the distortion components contained in the upper trace and appears as a virtual straight line (no distortion is present). If the same amplifier is

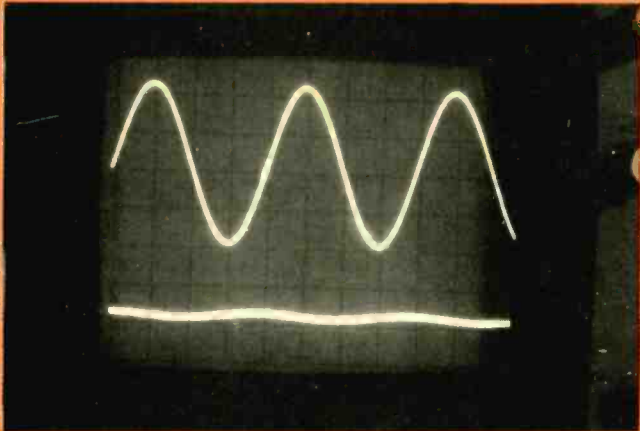

FIG. 3—HARMONIC DISTORTION CHARACTERISTICS. Upper trace shows output waveform. Lower trace shows only the harmonic components, which in this case is negligible.

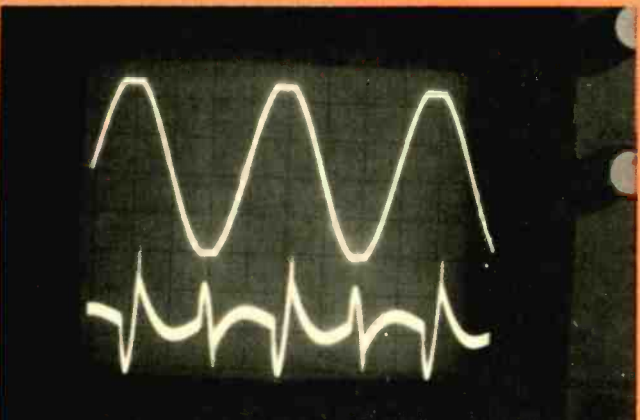

FIG. 4—AMPLIFIER CLIPPING produces harmonic distortion. Upper trace shows clipped output waveform; lower trace shows harmonic components.

driven beyond its power-output rating, the pure sine wave form will be clipped, as shown in Fig. 4. Under those circumstances, the distortion components (see the lower trace) are quite evident, and consist largely of third harmonic components. Harmonic distortion is specified in percent (%), and the lower the figure the better the amplification.

Another form of distortion that is usually specified is called IM (*Intermodulation Distortion*). This type of distortion arises when a complex of frequencies is fed to the amplifier instead of a single tone. In a poorly designed amplifier, high and low frequencies may beat against each other, causing sum-and-difference frequencies between the two to appear in the output of the amplifier. Since such musically unrelated frequency components were not present in the original signal, their presence at the amplifier's output, even in small percentages, can be quite disturbing to a listener. The IM distortion is also specified in percent, and the lower the figure the better.

More subtle forms of amplifier distortion have recently been discovered, but since accepted measurement standards for measuring them have not yet been agreed upon, harmonic and IM distortion are the two types most commonly found in the specifications sheets.

Figure 5 shows the IM and harmonic distortion-versus-power-output characteristics for a typical high-quality amplifier. Note that both forms of distortion remain quite low until the maximum power output is reached, at which time they tend to climb rapidly. That is why it is important to operate an amplifier within its power rating. To try to pump more power from an amplifier into a speaker that requires more than the amplifier can deliver leads to horrendous distortion levels.

We mentioned earlier that frequency response is cited for the preamplifier section in adherence to the prescribed RIAA equalization curve. In the case of the high-level sections of the amplifier, frequency response is quoted directly in hertz, and a tolerance or maximum deviation from flat response is included. The specification, "Frequency response: 20 Hz to 20 kHz" has no real meaning

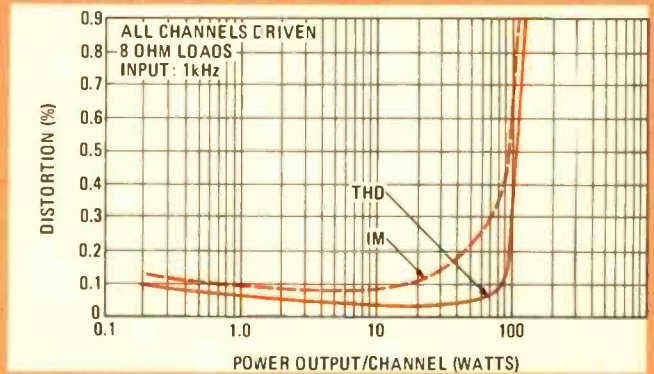

FIG. 5—HARMONIC AND IM distortion characteristics versus amplifier power output.

unless we also know the \pm dB-tolerance associated with the response over that frequency range. A proper response statement would read: Frequency response: flat from 20 Hz to 20,000 Hz, ± 0.5 dB, and this would be superior to one that stated: Frequency response: flat from 20 Hz to 20,000 Hz, ± 2.0 dB.

Signal-to-noise ratios relative to the high-level inputs also appear in the specifications and are quoted in dB (with the higher values being better), and are ordinarily higher than those listed for the phono section.

The specification called damping factor is a measure of an amplifier's ability to control or suppress unwanted residual motion of the speaker cone caused by the mechanical inertia or by forces other than the driving audio signal itself. Stated as a simple number, higher damping factor values are better, although damping factors higher than 40 to 50 contribute no audible improvement to an amplifier's performance.

Front-Panel Controls and Features

Unlike low-fidelity "table radios," most high-fidelity amplifiers are equipped with separate power on/off switches. This arrangement permits setting the volume control at preferred points when turning the unit on and off. The balance control adjusts right- and left-channel listening levels so that they are equal (or, if you must sit closer to one speaker system than to another, the balance control can be used to adjust for that situation).

The need for tone controls, whether simple bass and treble controls or more elaborate types, often puzzles audio neophytes. If all the components in an audio system produce a uniform or flat frequency response, why do you require tone controls, which, after all, are designed to provide adjustments that alter the overall system response from that flat quality? It is true that amplifiers can be made to have a frequency response which is "ruler flat"; however, this does not necessarily apply to the loudspeaker system or even to the listening room (which, in a very real sense, is a system component). For this reason, and because different people prefer different tonal balance, tone controls are a very necessary feature.

Some amplifiers, in an attempt to cater to the audio purist who prefers not to use tone controls, offer a tone DEFEAT switch or pushbutton that bypasses the tone control circuits completely. The standard BASS and TREBLE controls offer a wide range of adjustment, usually beginning above or below mid-frequencies (around 400 Hz to 1 kHz), as shown in Fig. 6. One disadvantage to this control range is the fact that when you want to boost extreme low or high frequencies (to compensate for deficient speaker bass or ultra-high treble) you necessarily also affect the response of frequencies that are closer to the middle of the audio range. To counteract this effect, some manufacturers offer tone controls having multiple turnover frequencies, as shown in Fig. 7. Still other amplifiers offer main- and sub-tone controls; the former effecting a wide frequency range, the latter boosting or attenuating only the extreme bass or treble range. Recently, some amplifiers have begun to include a mid-range tone control that acts upon the mid-frequency range similar to the way the bass and treble controls affect those frequencies. Fig. 8 shows the range typical of many mid-range tone controls.

A loudness switch is another control usually found on amplifier front panels. Studies of human hearing long ago confirmed that when we listen to music at lower-than-lifelike loudness levels, our hearing is less sensitive to extreme bass and treble frequencies than to mid-frequencies. Since in a home listening environment we often listen to music at "background" levels, reproduced music tends to sound thin and lacking in brilliance. To compensate for this effect, actuating the loudness control switch causes the amplifier to automatically boost the bass (and sometimes the treble) by an amount commensurate with the main volume-control setting. At high settings (where listening levels are presumably loud and therefore do not require compensation), no compensation is inserted, but as the volume is lowered, increased amounts of compensation are added automatically. Figure 9 shows the action of a volume/loudness control for different volume-control

settings. This compensates for the fact that the loudness of any tone is a function, not only of its intensity, but also of its frequency.

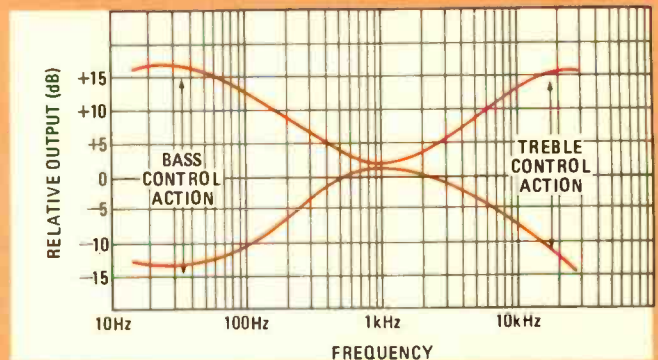

FIG. 6—TYPICAL RANGE of the bass and treble tone controls.

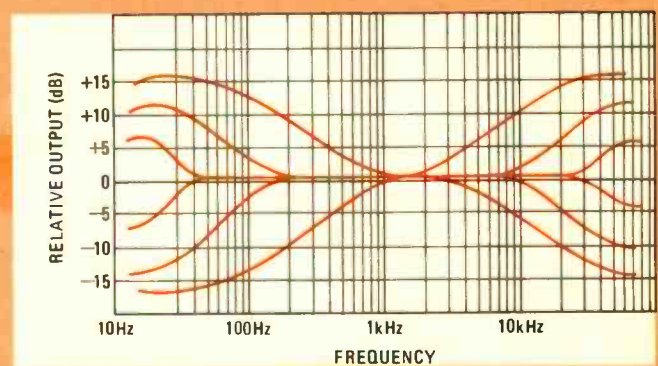

FIG. 7—ELABORATE TONE CONTROL circuitry include multiple user-selectable turnover frequencies.

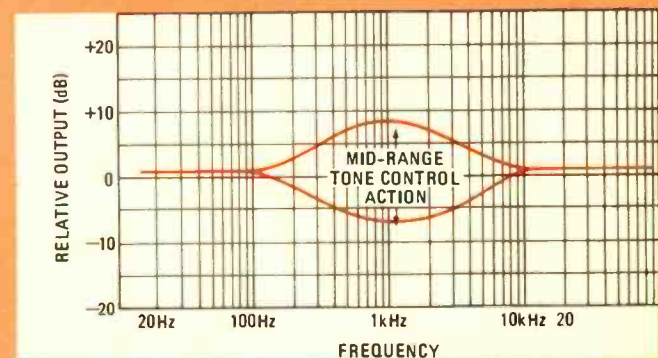

FIG. 8—MIDRANGE TONE CONTROL offers additional flexibility over standard bass and treble controls.

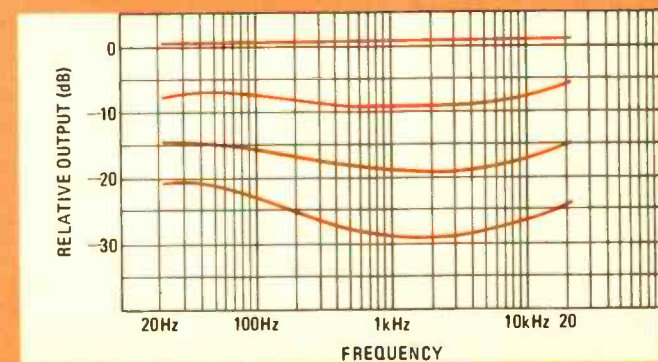

FIG. 9—LOUDNESS COMPENSATION decreases as the volume level is raised.

TABLE I
LOW-, MEDIUM- AND HIGH-PRICED AMPLIFIER SPECIFICATIONS AND RANGES

Specification	Low-cost	RANGES Mid-cost	High-priced
Harmonic distortion at rated output (%)	0.8-1.5	0.3-0.5	Less than 0.3
Harmonic distortion at 1-watt output (%)	0.2-0.5	0.05-0.1	Under 0.95
IM distortion at rated output (%)	1.0-2.0	0.3-1.0	Under 0.3
IM distortion at 1-watt output (%)	0.5-1.0	0.2-0.5	Under 0.2
Power bandwidth for full power (hz-kHz)	40-10	20-20	20-20 or better
Damping factor	10-15	15-30	30 or higher
Phono S/N, unweighted referred to input sensitivity (dB)	50-60	60-68	Above 68
Phono S/N, "A"-weighted, referred to 5-mV input & 1-watt (or 0.5 volt for preamplifiers) output, per new IHF Standards (dB)	60-65	65-75	Above 75
High-level input S/N, unweighted, referenced to full rated output (dB)	65-75	75-80	Above 80
High-level input S/N, "A"-weighted, referenced to 0.5-volt input and 1.0-watt (or 0.5-volt, for preamplifiers) output, per new IHF Standards (dB)	60-70	70-75	Above 75
Residual hum and noise referenced, to full output, unweighted (dB)	75-85	85-95	Above 95
Residual hum and noise, "A"-weighted, referenced to 1-watt (or 0.5-volt for preamplifiers) output (dB)	70-80	80-90	Above 90
Phono frequency response (RIAA—dB)	± 1.0-2.0	± 0.5-1.0	± 0.3 or less
High-level input frequency response (Hz-kHz, dB)	20-20, ± 2.0	15 Hz-25 kHz, ± 1	10-30, ± 0.5 or better
Phono overload (mV)	50-70	80-100	Greater than 100

(NOTE: The power output of an amplifier is not an indication of its quality, but is dictated by price and design objectives.)

Another form of tone-altering control is the filter circuit. Low- and high-cut filter switches, often found on the front panels of amplifiers, attenuate frequencies above or below their respective cutoff points more steeply than regular bass and treble controls. Figure 10 shows a comparison between the action of tone controls and steep-cut filters. Such filters, if properly designed, are effective in reducing high-frequency hiss or noise, and in lessening the audible effect of lower-frequency turntable rumble without impinging too severely on the music.

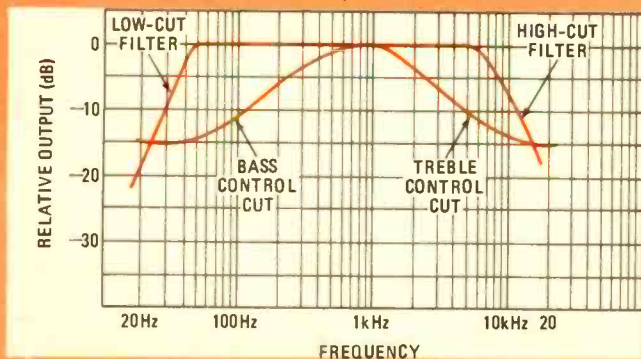

FIG. 10—COMPARISON of tone control action and the effects of the high- and low-cut filters.

The final decision

Up to this point, a great many amplifier specifications have been examined and, indeed, published specs are important parameters for choosing this important hi-fi component. We would never suggest, however, that published specifications tell the whole story. There are still a great many audio amplifier characteristics that cannot be defined or measured—at least not with state-of-the-art instruments and techniques.

There is one ultrasensitive instrument you should use in making a final choice—your own ears. Compare specifications and pricing, of course, but in the last analysis let your ears serve as the final judge. Listen to several amplifiers in the price and power category which you seek. Use a wide variety of musical programs to make these subjective sound quality judgments. Listen at low and high levels—until you are sure that you have chosen the right amplifier for your own selected high-fidelity system.

As a final aid, a brief summary of the specifications we have discussed appear in Table I. The values shown in the table can serve as a general guide only and may not conform in all cases to what is available in the audio marketplace. We hope, however, that this summary helps get you started and wish you good listening.

R-E

STEREO-AMPLIFIER ROUNDUP

MANUFACTURER	MODEL	PRICE	POWER OUTPUT CAPABILITY											DISTORTION					PHONO PREAMPLIFIER					HIGH-LEVEL INPUT				COMPONENT MATCHING		
			8 Ω , @ 1kHz (W)	8 Ω , @ 20Hz (W)	8 Ω , @ 20kHz (W)	4 Ω , @ 1kHz (W)	4 Ω , @ 20Hz (W)	4 Ω , @ 20kHz (W)	FREQUENCY LIMITS FOR RATED OUTPUT (Hz-kHz)	DYNAMIC HEADROOM (dB)	HD @ RATED OUTPUT, 1kHz (%)	IM @ RATED OUTPUT (%)	HD @ 1W, 1kHz (%)	IM @ 1W, 1kHz (%)	DAMPING FACTOR 50Hz, 8 Ω	FREQUENCY RESPONSE (Hz-kHz)	MAX INPUT BEFORE OVERLOAD (mV)	S/N RATIO "A", "WTO" RE, 1W OR 0.5V OUT FOR 5mV IN (dB)	FREQUENCY RESPONSE (Hz-kHz, \pm dB)	"A", "WTO, RE, 0.5V OR 1W OUTPUT (dB)	RESIDUAL NOISE "A", "WTO, MIN VOLUME, RE, 1W OUTPUT (dB)	HI LEVEL, RE, 1W OR 0.5V OUTPUT (mV)	HI LEVEL, RE, 1W OR 0.5V OUTPUT (mV)	HI LEVEL, RE, 1W OR 0.5V OUTPUT (mV)	TAPE OUTPUTS @ RATED OUTPUT (mV)	HEADPHONE JACK @ RATED OUTPUT (mV OR mW)				
AIWA	AA8700U	\$ 550.00	75	75	85	85	85	20-20	20-20	0.02	0.02	0.01	0.02	>401 30Hz~ 15kHz \pm 0.2dB	280	83	5-100 +0, -3	110	0.3mV	150	150	150	150	150	150	150	150	150		
	SCA-50	\$199K \$299W	25	25	85	85	20-20	20-20	<0.25	<0.1	<0.25	<0.1	80 \pm 1dB	100 ²	72 ³	15-45 \pm 0.5	89 ³	125 ⁴	150											
	2530	\$ 749.00	100	100	200	200	20-20	20-20	<0.05	<0.2	<0.05	<0.2	80 \pm 1dB	100 ²	80	10-50 \pm 0.5	85 ³	1.25 ⁵	150											
H. H. SCOTT	480A	\$ 499.95	75	75	85	85	20-20	20-20					100@ 1kHz	250/ 500	84	20-20 \pm 0.5	88	90	16.3	0.27/ 0.54	150	150	150	150	150	150	750mV @8 Ω			
	460A	\$ 429.95	75	75	85	85	20-20	20-20					100@ 1kHz	250/ 500	84	20-20 \pm 0.5	88	90	17.9	0.30/ 0.60	250	250	250	250	250	680mV @8 Ω				
	440A	\$ 349.95	75	75	85	85	20-20	20-20					100@ 1kHz	180	79	20-20 \pm 0.5	83	85	20.2	0.37	150	150	150	150	150	600mV @8 Ω				
	420A	\$ 249.95	65	65	85	85	20-20	20-20					60@ 1kHz	180	74	20-20 \pm 1	78	80	23.7	0.40	150	150	150	150	150	515mV @8 Ω				
HITACHI	HA3500	\$ 200.00	30	30	40	40	20-20	20-20	0.05	0.03	0.05	0.03	30 \pm 0.3	200	75				2.5											
	HA4500	\$ 250.00	40	40	50	50	20-20	20-20	0.05	0.03	0.05	0.03	30 \pm 0.3	200	75				2.5											
	HA5100	\$ 450.00	50	50	65	65	5-20	1.75	0.02	0.008	0.02	0.008	60 \pm 0.2	300	86	10-100 +0-2.5	100													
	HA7700	\$ 600.00	65	65	85	85	5-20	1.75	0.02	0.008	0.02	0.008	60 \pm 0.2	300	86	10-100 +0-2.5	100													

CIRCLE NUMBER 120 ON FREE INFORMATION CARD FOR LIST OF ADDRESSES.

MANUFACTURER	MODEL	PRICE	POWER OUTPUT CAPABILITY										DISTORTION					PHONO PREAMPLIFIER				HIGH-LEVEL INPUT				COMPONENT MATCHING		
			8 Ω , @ 1kHz (W)	8 Ω , @ 20Hz (W)	8 Ω , @ 20kHz (W)	4 Ω , @ 1kHz (W)	4 Ω , @ 20Hz (W)	4 Ω , @ 20kHz (W)	20-20 (Hz-kHz)	DYNAMIC HEADROOM (dB)	HD @ RATED OUTPUT, 1kHz (%)	IM @ RATED OUTPUT (%)	HD @ 1W, 1kHz (%)	IM @ 1W (%)	DAMPING FACTOR 50Hz, 8 Ω	FREQUENCY RESPONSE (RIIA \pm dB)	MAX INPUT BEFORE OVERLOAD (mV)	S/N RATIO "A"-WT.D RE. 1W OR 0.5V OUT FOR 5mV IN (dB)	FREQUENCY RESPONSE (Hz-kHz, \pm dB)	"A"-WT.D, RE. 0.5 OR 1W OUTPUT (dB)	RESIDUAL NOISE "A"-WT.D, MIN VOLUME, RE. 1W OUTPUT (dB)	RE. 1W OUTPUT (dB)	HI LEVEL, RE. 1W OR 0.5V OUTPUT (mV)	HI LEVEL, RE. 1W OR 0.5V OUTPUT (mV)	INPUT SENSITIVITY (mV)	TAPE OUTPUTS @ RATED OUTPUT (mV)	HEADPHONE JACK @ RATED OUTPUT (mV OR mW)	
JVC US JVC CORP	JA-S77	\$ 429.95	70	65	90	90	20-20	0.005	0.01	0.005	0.005	0.005	0.005	50	0.2	280	87	3-100 +0, -1	112	112	2.5	200	200	200	200	200	200	200
	JA-S55	\$ 339.95	65	60	70	70	20-20	0.005	0.01	0.005	0.005	0.005	50	0.3	230	87	5-100 +0, -1	112	112	2.5	200	200	200	200	200	200	200	
	JA-S44	\$ 339.95	48	45	60	60	20-20	0.005	0.01	0.005	0.005	0.005	30	0.3	200	86	5-100 +0, -2	108	108	2.5	160	160	160	160	160	160	160	
	JA-S22	\$ 239.95	43	40	50	50	20-20	0.01	0.01	0.01	0.01	0.01	30	0.3	200	86	5-100 +0, -2	108	108	2.5	160	160	160	160	160	160	160	
	A-M1	\$ 599.95	50	50	50	50	20-20	0.009					30	0.3	200	88		112	112	2.5	150	150	150	150	150	150	150	
	A-S7	\$ 229.95	50	50	50	50	20-20		0.05				50	0.5	200	86		107	107	2.5	107	107	2.5	200	200	200	200	
	A-S5	\$ 179.95	30	30	30	30	20-20		0.08				50	0.5	150	81		102	102	2.5	102	102	2.5	200	200	200	200	
A-S3	\$ 149.95	20	20	20	20	20-20		0.08				30	0.5	150	78		102	102	2.5	102	102	2.5	200	200	200	200		
NEW ACOUSTIC DIMENSION	3030	\$ 220.00	40	40	50	50	20-20	2.2	<.09	<.09	<.02	<.02	50	\pm 0.3	190	>74	\pm 0.5	>80 ⁶	>80 ⁶	150 ⁷	150 ⁷	150 ⁷	150 ⁷	150 ⁷	150 ⁷	150 ⁷	150 ⁷	
	3045	\$ 295.00	60	60	80	80	20-20	2.2	<.05	<.05	<.02	<.02	75	\pm 0.3	200	>76	\pm 0.5	>80 ⁶	>80 ⁶	150 ⁷	150 ⁷	150 ⁷	150 ⁷	150 ⁷	150 ⁷	150 ⁷	150 ⁷	
	3060	\$ 380.00	80	80	120	120	20-20	2.2	<.03	<.03	<.02	<.02	100	\pm 0.3	200	>76	\pm 0.5	>80 ⁶	>80 ⁶	150 ⁷	150 ⁷	150 ⁷	150 ⁷	150 ⁷	150 ⁷	150 ⁷	150 ⁷	
	3080	\$ 465.00	130	130	160	160	20-20	2.5	<.03	<.03	<.02	<.02	120	\pm 0.3	200	>76	\pm 0.5	>80 ⁶	>80 ⁶	150 ⁷	150 ⁷	150 ⁷	150 ⁷	150 ⁷	150 ⁷	150 ⁷	150 ⁷	
NIKKO	NA-590	\$ 209.95	35	35	50	50	20-20	1.00	0.05	0.05	0.05	60	1	138	82	10-50 \pm 0.5	90	90	2.3 ⁸	150	150	140	140	140	140	25mW		
	NA-690	\$ 249.95	50	45	55	55	20-20	1.07	0.04	0.04	0.04	60	\pm 0.2	210	85	20-20 \pm 0.5	100	100	2.3 ⁸	150	150	150	150	150	150	25mW		
	NA-890	\$ 349.95	75	70	80	80	20-20	0.84	0.04	0.04	0.03	60	\pm 0.2	220	85	10-20 \pm 0.5	100	100	2.3 ⁸	150	150	150	150	150	150	70mW		
OPTONICA	SM3201	\$ 250.00	45	40	40		20-20	0.19	0.1	0.15	0.1	>40 ²	0.3	240	82 ⁹	10-80 +1, -3	85 ¹⁰	65	23.7	23.7	23.7	150	150	150	150	630mV		
	SM3205	\$ 250.00	45	40	40		20-20	0.19	0.1	0.15	0.1	>40 ²	0.3	240	82 ⁹	10-80 +1, -3	85 ¹⁰	65	23.7	23.7	23.7	150	150	150	150	630mV		
	SM3636	\$ 320.00	65	60	60		20-20	0.09	0.1	0.09	0.1	>45 ²	0.25	240	86 ⁹	10-70 \pm 1.5	90 ¹⁰	70	23.7	23.7	23.7	150	150	150	150	630mV		
	SM4646	\$ 460.00	85	80	80		20-20	0.08	0.1	0.09	0.1	>45 ²	0.18	370	86 ⁹	10-80 \pm 1.5	90 ¹⁰	82	23.7	23.7	23.7	150	150	150	150	770mV		

MANUFACTURER	MODEL	PRICE	POWER OUTPUT CAPABILITY							DISTORTION				PHONO PREAMPLIFIER					HIGH-LEVEL INPUT				COMPONENT MATCHING								
			8 Ω , @ 1kHz (W)	8 Ω , @ 20kHz (W)	8 Ω , @ 20kHz (W)	4 Ω , @ 1kHz (W)	4 Ω , @ 20kHz (W)	4 Ω , @ 20kHz (W)	4 Ω , @ 20kHz (W)	10-50	FREQUENCY LIMITS FOR RATED OUTPUT (Hz-kHz)	DYNAMIC HEADROOM (dB)	HO @ RATED OUTPUT, 1kHz (%)	IM @ RATED OUTPUT (%)	HO @ 1W, 1kHz (%)	IM @ 1W (%)	DAMPING FACTOR 50Hz, 8 Ω	FREQUENCY RESPONSE (RIA A \pm dB)	MAX INPUT BEFORE OVERLOAD (mV)	S/N RATIO "A", W.T.O. RE 1W OR 0.5V OUT FOR 5mV IN (dB)	R.E. 1W OR 0.5V OUT	FREQUENCY RESPONSE (Hz-kHz \pm dB)	"A", W.T.O. RE 1W OR 0.5V OUTPUT (dB)	"A", W.T.O. RE 0.5 OR 1W OUTPUT (dB)	RESIDUAL NOISE RE 1W OUTPUT (dB)	"A", W.T.O. MIN VOL. RE 1W OUTPUT (dB)	HO LEVEL, RE 1W OR 0.5V OUTPUT (mV)	HI LEVEL, RE 1W OR 0.5V OUTPUT (mV)	INPUT SENSITIVITY (mV)	TAPE OUTPUTS @ RATED OUTPUT (mV)	OUTPUT LEVEL (mV OR mW)
PIONEER	SA-9800	\$ 750.00	100	100	100	120	120	120	10-50		0.005	0.002	0.004	0.002	55 \pm 2	\pm 0.2 \pm 1	250	90 \pm 3	5-100 +0, -1	110 \pm 4	.5	150	150			150	150	150	150	150	
	SA-8800	\$ 550.00	80	80	100	100	100	10-50		0.005	0.002	0.004	0.002	55 \pm 2	\pm 0.2 \pm 1	250	90 \pm 3	5-100 +0, -1	110 \pm 4	.5	150	150			150	150	150	150	150		
	SA-7800	\$ 450.00	65	65	80	80	80	10-50,000		0.009	0.003	0.007	0.003	55 \pm 2	\pm 0.2	200	87 \pm 3	5-100 +0, -1	110 \pm 4	.5	150	150			150	150	150	150	150		
	SA-7700	\$ 375.00	60	60	60	60	60	20-20,000		0.04	0.04	0.03	0.02	40 \pm 2	\pm 0.2	180	86 \pm 3	20-40 \pm 2	95 \pm 4	.5	150	150			150	150	150	150	150		
	SA-6700	\$ 250.00	40	40	40	40	40	20-20,000		0.05	0.05	0.03	0.02	30 \pm 2	\pm 0.3	180	78 \pm 3	20-40 \pm 2	95 \pm 4	.5	150	150			150	150	150	150	150		
RADIO SHACK	SA-1001	\$ 179.95	35	35	52	52	56	20-20		.014	0.5 \pm 24	.025			\pm 1.0	150		20-20 \pm 1.5	0.5mV	25	0.36	150	150			150	150	150	150	150	
	SA-2001	\$ 279.95	60	60	78	78	76	20-20		.04	0.1 \pm 25	.035			\pm 1.0	180		20-20	0.5mV	25	0.19	200	200			200	200	200	200	200	
ROGERS	A 75	\$ 520.00	55	45	50	45	36	40	30-30		0.08	0.08	0.005	0.006	30	\pm 2	>80	-70							2.7, 4.0, 63.0, 90.0	180	180	180	180	180	20
SAE	2922	\$ 850.00	100	100	100	100	100	20-20		0.05	0.05	0.05		150	\pm 0.25	150	84	20-20 \pm 0.25	85.6	80	80	60	60			60	60	60	60	60	
	3022	\$ 700.00	100	100	100	100	100	20-20		0.05	0.05	0.05		150	\pm 0.25	150	81	20-20 \pm 0.25	75.6	60	60	60	60			60	60	60	60	60	
	3031	\$ 550.00	50	50	50	50	50	20-20		0.05	0.05	0.05		150	\pm 0.25	150	81	20-20 \pm 0.25	75.6	60	60	60	60			60	60	60	60	60	
	SAE TWO C3A	\$ 325.00	50	50	50	50	50	20-20		0.05	0.05	0.05		30	\pm 0.25	150	79	20-20 \pm 0.25	70	60	60	60	60			60	60	60	60	60	
SANSUI	AU-X1	\$1450.00	160	160	160	160	160	5-20		0.007	0.007	0.007	0.007	100	0.2	330	97	5-500 +0, -3	110	200	110	200	200			200	200	200	200	200	
	AU-919	\$ 800.00	110	110	110	110	110	5-20		0.008	0.008	0.008	0.008	100	0.2	320	96	5-100 +0, -3	110	150	110	150	150			150	150	150	150	150	
	AU-717	\$ 550.00	85	85	85	85	85	10-20		0.015	0.015	0.015	0.015	60	0.2	350	86	5-100 +0, -3	110	150	110	150	150			150	150	150	150	150	
	AU-417	\$ 395.00	65	65	65	65	65	20-20		0.02	0.02	0.02	0.02	60	0.2	300	86	5-100 +0, -3	110	150	110	150	150			150	150	150	150	150	
	AU-317	\$ 350.00	50	50	50	50	50	20-20		0.03	0.03	0.03	0.03	70	0.2	200	83	5-70 +0, -1.8	110	150	110	150	150			150	150	150	150	150	
	AU-21711	\$ 230.00	40	40	40	40	40	20-20		0.06	0.06	0.06	0.06	80	0.5	200	82	10-50 \pm 0.5	105	150	105	150	150			150	150	150	150	150	
	AU-11711	\$ 190.00	50	50	50	50	50	20-20		0.17	0.17	0.17	0.17	50	0.5	160	82	10-40 +0.5, -2	105	150	105	150	150			150	150	150	150	150	

MANUFACTURER	MODEL	PRICE	POWER OUTPUT CAPABILITY										DISTORTION					PHONO PREAMPLIFIER					HIGH-LEVEL INPUT					COMPONENT MATCHING		
			82, @ 1kHz (W)	82, @ 20kHz (W)	82, @ 20kHz (W)	42, @ 1kHz (W)	42, @ 20kHz (W)	42, @ 20kHz (W)	82, @ 20kHz (W)	82, @ 1kHz (W)	IM @ RATED OUTPUT, 1kHz (%)	IM @ RATED OUTPUT (%)	HD @ 1W, 1kHz (%)	IM @ 1W (%)	DAMPING FACTOR 50Hz, 8Ω	FREQUENCY RESPONSE (RIAA ±dB)	MAX INPUT BEFORE OVERLOAD (mV)	S/N RATIO "A"-WT.O. RE. 1W OR 0.5V OUT FOR 5mV IN (dB)	FREQUENCY RESPONSE (Hz-kHz, ±dB)	"A"-WT.O. RE. 0.5V OR 1W OUTPUT (dB)	RESIDUAL NOISE "A"-WT.O. MIN VOLUME, RE. 1W OUTPUT (dB)	RE. 1W OUTPUT (dB)	OR 0.5V OUTPUT (mV)	OR 0.5V OUTPUT (mV)	HI LEVEL, RE. 1W OR 0.5V OUTPUT (mV)	HI LEVEL, RE. 1W OR 0.5V OUTPUT (mV)	TAPE OUTPUTS @ RATED OUTPUT (mV)	HEADPHONE JACK @ RATED OUTPUT (mV OR mW)		
SERIES 20	A-27	\$1300.00	120	120	180	180	180	180	180	180	0.012	0.006	0.008	0.005	170	±0.2	300	90 ¹⁵	100 ²³			8.33	500	150						
SONY	TA-F68	\$ 610.00	100	100						.03				50	±.2	250	91		2-150 +0, -1	105	150	150								
	TA-F5A	\$ 350.00	70	70						.01				40	±.2	250	91		3-70 +0, -1	100	150	150								
	TA-F3A	\$ 240.00	50	50						.5				30	±.5	250	81		10-60 +0, -3	95	150	150								
TECHNICS	SU-8099	\$1000.00	115	115	170	150	150	150	150		0.007 ¹⁶	0.007	0.0025 ¹⁷	100 ¹⁸	±0.15	250	96 ¹⁹	20-20 +0, -0.1	110 ²⁰	0.3mV ²¹	200 ²²	200								
	SU-8088	\$ 600.00	80	80	95	90	90	90	90		0.0116	0.01	0.003 ¹⁷	50 ¹⁸	±0.2	250	96 ¹⁹	20-20 +0, -0.1	110 ²⁰	0.3mV ²¹	200 ²²	200								
	SU-8077	\$ 450.00	60	60	80	65	65	65	65		0.0216	0.02	0.003 ¹⁷	40 ¹⁸	±0.2	150	94 ¹⁹	20-20 +0, -0.1	108 ²⁰	0.3mV ²¹	200 ²²	200								
	SU-8055	\$ 300.00	50	47	56	48	48	48	48		0.0216	0.02	0.00817	36 ¹⁸	±0.5	150	86 ¹⁹	20-20 ±0.5	97 ²⁰	0.6mV ²¹	150 ²²	150								
THORENS	SU-8044	\$ 260.00	40	38	46	40	40	40	40		0.0216	0.02	0.00817	32 ¹⁸	±0.8	150	86 ¹⁹	20-20 ±0.5	97 ²⁰	0.6mV ²¹	150 ²²	150								
	AT410	\$1195.00	50	50	55	55	55	55	55		<0.1	<0.05	<0.05	<50	±0.5	70	<65	20-20 ±0.5	<68	<68	180	180				10V INTO 600Ω				
	AT403	\$ 895.00	30	30	35	35	35	35	35		<0.1	<0.05	<0.05	<35	±0.5	70	<65	20-20 ±0.5	<68	<68	180	180						10V INTO 600Ω		

NOTES:

- 1-AT 20Hz~20kHz
- 2-AT 1kHz
- 3-UNWEIGHTED
- 4-FOR 25W OUT
- 5-FOR 100W@8Ω
- 6-S/N RATIO
- 7-FOR RATED POWER
- 8-FOR PHONO INPUT
- 9-10mV IN
- 10-RATED POWER
- 11-20Hz~20kHz
- 12-MINIMUM
- 13-REFERENCE TO 2.5mV INPUT PRODUCING 1.0V PRE-OUT AND RATED OUTPUT POWER
- 14-RE. 150mV INPUT PRODUCING 1.0V PRE-OUT AND RATED OUTPUT POWER
- 15-REF 120W, 205mV IN
- 16-THD AT RATED OUTPUT, 20Hz TO 20kHz
- 17-THD AT 1/2 POWER, 1kHz
- 18-DAMPING FACTOR AT 1kHz ACROSS 8 OHMS
- 19-S/N RATIO ("A"-WEIGHTED) WITH 5mV INPUT
- 20-"A"-WEIGHTED S/N RATIO AT RATED POWER
- 21-RESIDUAL NOISE "A"-WEIGHTED, IN mV
- 22-HIGH LEVEL INPUT SENSITIVITY FOR RATED OUTPUT. THE SAME FIGURE APPLIES TO AUX, TUNER AND TAPE POSITIONS
- 23-REF 120W, 150mV IN
- 24-AT 30 WATTS
- 25-AT 50 WATTS

Audio Test Station

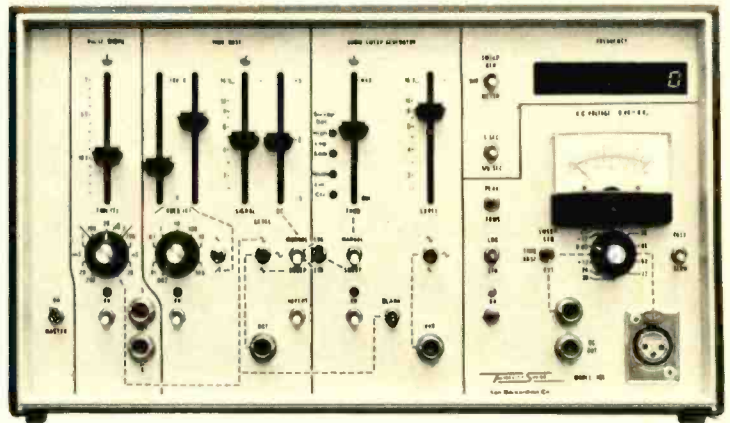

Part 4—This month we discuss in detail the theory of operation and the construction of the voltmeter and digital frequency meter that are essential to maximum usage of this audio test station.

RAY DAVISON

THIS MONTH, WE CONCLUDE THE CONSTRUCTION details of the Audio Test Station with the voltmeter and frequency counter sections.

Voltmeter section

The voltmeter circuit shown in Fig. 10 has two separate inputs. One is labelled EXT INPUT, which is a high-impedance low-gain input for line-level signals and the other is labelled MIKE INPUT, which is a low-impedance, high-gain input for low-level low-impedance signals. The front panel connector for the MIKE INPUT (J6) is a standard XLR type. The mike input circuitry consists of IC601 and its associated components, which form a balanced-line receiver. Resistor R601 terminates the line and R603 and R602 set the gain of IC601. The gain as seen from pin 3 of J6 is 16. The gain of the + input of IC601 is $16 + 1$ or 17. Therefore, R603 and R604 are added to form a voltage divider so the overall gain of a signal applied at J6 pin 2 is the same as for a signal applied at J6 pin 3. This satisfies the basic purpose for having a balanced transmission line, namely common-mode rejection.

The balanced transmission line reduces the effect of stray signals picked up by interconnecting cables. The most susceptible stray pickup point in sound systems is a microphone cable. It is not that the mike cable itself is more susceptible, but rather that the microphone supplies such a low-level signal that it is relatively easy to pick up enough of a stray signal to be audible when mixed and amplified with the mike signal. The stray signal is often induced into a mike cable when the cable is in the presence of an electric or

magnetic field.

The mike input circuitry inverts the signal applied to J6 pin 3, while the signal applied to pin 2 is not inverted. The actual mike signal that is applied to J6 pin 3 is of equal magnitude and opposite polarity of that which is applied to pin 2. Op-amp IC601 inverts the negative signal at pin 3, and adds this to the positive signal at pin 2.

When stray signals that are induced into the cable arrive at J6 pins 2 and 3 in phase, the signal at pin 3 is inverted and added to that at pin 2. However, this is subtraction. The result is what is known as common-mode rejection. A signal that was common to both inputs is rejected.

This circuit is normally shown with the four resistors of high precision and fixed value. In this circuit the common-mode rejection is simply trimmed by R604. To do this, connect a signal simultaneously at J6 pins 2 and 3. A mid-frequency sine-wave at about a half a volt peak-to-peak is suitable. Set S17 to -72 dB, adjust R604 for minimum output from IC603. The signal at the output of IC603 should be about the same magnitude as the input signal. Note that the same signal applied to either input alone would have been amplified by about 4,000 or 72 dB. Therefore, since the signal was passed with a gain of approximately 1, the common-mode rejection ratio is the 72 dB that the signal would ordinarily have been amplified by.

We have used this type of mike preamp in sound systems with mike cable lengths of well over 100 feet without any apparent extraneous pickup. However, for sound system use, the 748 is much too noisy. This can be easily remedied though by replacing the 748 with something like TI's TL071. The two parts are pin-compatible, and the 5-PE compensation

capacitors used for the 748 can even be left in place when switching to the TL071. The difference in noise levels is dramatic.

A second-stage preamp consisting of IC602 is included. Having the preamp in two stages accomplishes a couple of things. First, the supply voltages are rather close to the maximum output voltage. A single amplifier with 48-dB gain and with an attenuator at the output would clip at signal amplitudes intended for the low-gain attenuator setting. In fact a signal which yields full scale on the -30 -dB setting causes IC602 to clip.

Another reason for cascading is that the overall bandwidth is increased. This allows two common op-amps to be used in place of a single high-frequency unit.

Switch S16 selects one of three high-level inputs. The sweep generator and timebase pickup points are on the inboard side of the fuse that is used in conjunction with the output overvoltage sensors. Therefore, if there is no output from the sweep generator or timebase but its level can be read on the meter, it indicates a blown fuse. Capacitor C603 blocks any DC component present at S16. Resistors R610 through R615 form the actual input attenuator. Consider for the moment just this resistor string and S17. There is stray capacitance between every node of that resistor string and every other node. The result is a very complex R-C filter. At low frequencies, it is a simple voltage divider whose transfer function can be easily determined by simple arithmetic. Higher frequencies, however, travel from node to node in a manner that is quite difficult to predict accurately.

Capacitors C604 through C609 are added as an attempt to swamp out the internodal stray capacitance. This is

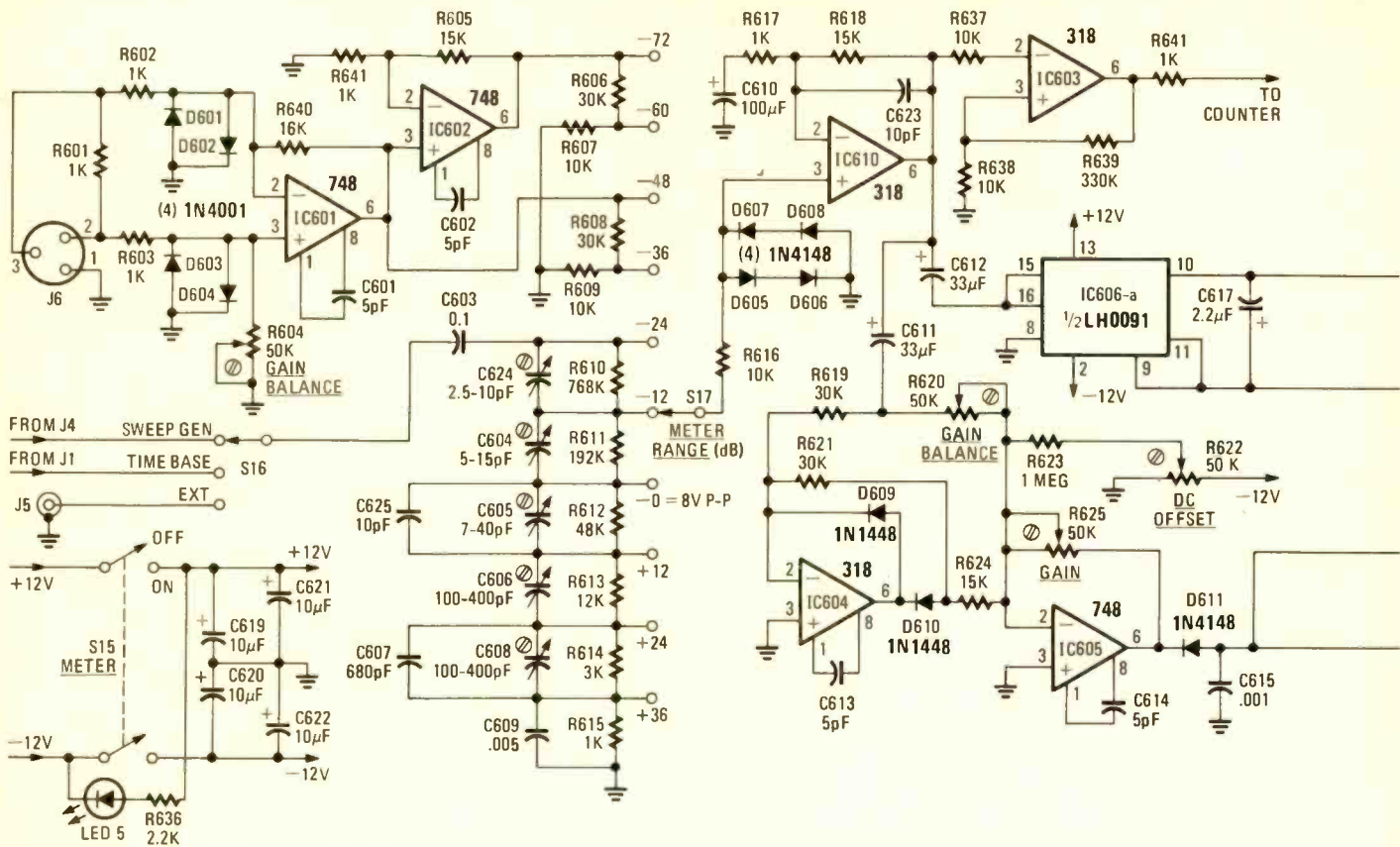

FIG. 10—SCHEMATIC DIAGRAM of the voltmeter. Its input circuitry uses frequency compensation. The separate preamp is for low-level inputs. The 1.5K resistor near the meter is R643, not R635.

called attenuator compensation. For purposes of simple compensation, the absolute capacitance values are relatively unimportant except that they must properly relate proportionately to the resistors that they are parallel with and the stray capacitances they are combining with. However, it is generally desirable to keep these capacitors small so as to minimize the total capacitance seen from the input.

If this were the input attenuator to an oscilloscope where waveform purity is of great importance, a low capacitance switch would be necessary. This is typically a large open-frame type with relatively large intercontact spacing. In this system, the problem is somewhat intensified by the use of a miniature switch where all nodes are in very close proximity. However, it is quite satisfactory up to at least 100 kHz, which should satisfy the needs of the system.

To adjust the compensating capacitors, monitor the output of IC603 with a scope. Apply a 10–15-kHz squarewave to the input and move S17 through each of the relevant positions. Adjust the capacitor immediately below the selected switch position for best squarewave response. Initial calibration of the attenuator will require several trials to bring the trimmers into proper relationship with each other. Once the adjustment is made with a squarewave input, a sinewave can be applied and swept from 10 kHz to 100 kHz to verify the overall response. Some fine tuning may be helpful at this time.

Assuming the sinewave from the time-

base would be used for this last check, recall that the timebase begins a noticeable rolloff around 100 kHz. So be sure that any compensation adjustments made with the sinewave input are not compensating for timebase rolloff.

An additional gain stage and attenuator buffer consisting of IC603 is provided. Diodes D605 through D608 provide protection against excessive voltage applied to the external input. With S17 in the –24-dB position, IC603 is connected essentially straight to the external input. The diodes conduct at about 1 volt and are capable of 50 milliamps. Resistor R616 is intended to limit the diode current to a safe level. However, R616 cannot be arbitrarily large since it combines with the capacitance at the input of IC603 to form a low-pass filter. Since the diodes can handle 50 milliamps, 500V can be applied without damaging them. However, the power-handling capability of R616 must be considered at a fraction of that voltage level. If R616 is a half-watt resistor, it will tolerate 70 volts. The resistor can tolerate larger voltage levels than that for short periods of time. Since even a much smaller level will cause the meter to peg, if the operator is attentive, a 10K half-watt resistor should be adequate.

However, for insured safety R16 can be replaced with a positive temperature coefficient thermistor of approximately 10,000 ohms cold resistance. Such a device is a self-protecting resistor, since as excessive power causes it to heat, its

resistance increases, which decreases the power and hence the heating effect. Also, keep in mind that R616 is of no-particular value and need only be large enough to protect the diodes and small enough not to degrade high-frequency performance.

IC610 is a comparator with hysteresis. A zero-crossing dejector is formed by applying a signal through an isolation resistor to the negative input. Applying positive feedback causes the detection point to shift, which results in a circuit that ignores signals smaller than the detection levels.

This circuit preconditions the voltmeter signal before it is applied to the counter. For the circuit shown, the overall result is that the counter will count an input whose magnitude is 10% of the full-scale setting selected by S17.

IC604 through IC607 form the AC-to-DC converter. IC604 and IC605 are a full-wave rectifier. One-half of an applied waveform is inverted and added to the noninverted half. Resistor R630 adjusts the relative gain of the inverted and noninverted parts of this waveform. Trimmer R625 adjusts the overall gain of the rectified waveform.

Components D611, C615 and IC606 form a peak detector. When the signal from IC605 goes positive, diode D611 conducts charging C615. Capacitor C615 is small and hence charges as fast as the voltage from IC605 rises. When the output of IC605 passes a peak and starts to decrease, diode D611 cuts off and IC606 is left with charged C615 on its input.

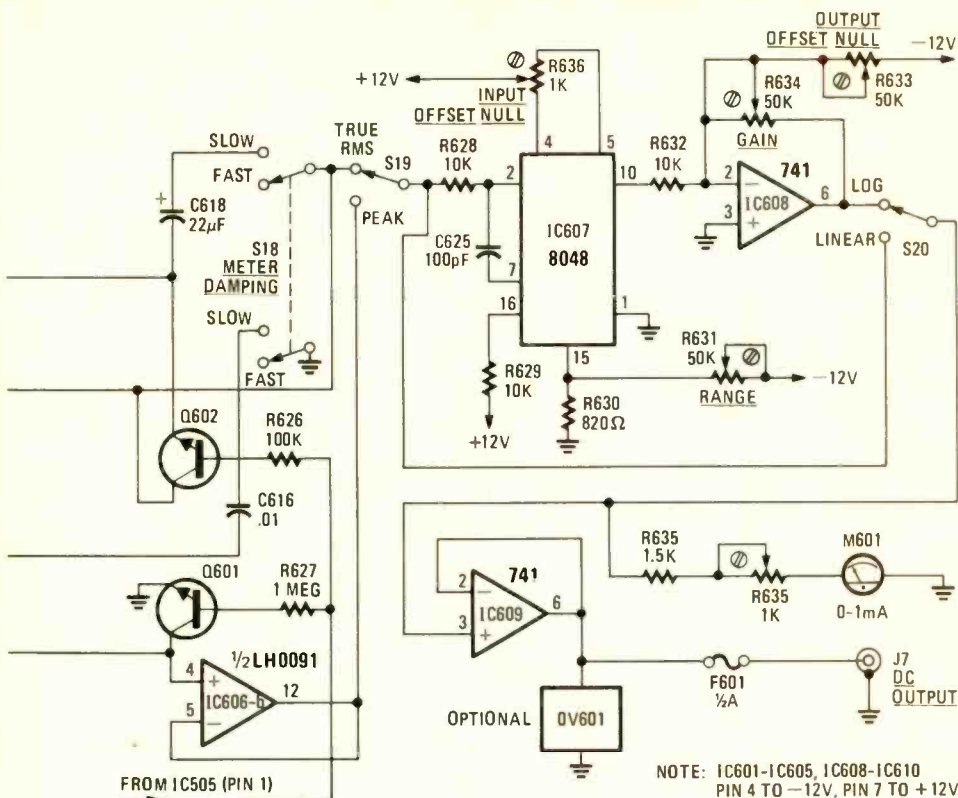

NOTE: IC601-IC605, IC608-IC610
PIN 4 TO -12V, PIN 7 TO +12V

Capacitor C615 discharges through the input of IC606. The rate at which C615 discharges is called the droop rate. Note that when D611 is cut off, IC606 has no DC bias on the + input. This results in a negative offset from IC606 equal to 1 diode-drop. Trimmer R622 shifts the output of IC605 enough to compensate for this and hence zero the output of IC606.

Note that the three diodes in the circuit do not exhibit the $\frac{1}{10}$ -volt threshold normally associated with a diode. The threshold is reduced to a negligible level by the active circuitry with which the diodes are associated.

The result so far then is a full-wave peak detector that will track an increasing amplitude instantaneously and track a decreasing amplitude at a slower rate, this rate being determined by the capacitor, and hence the droop rate is rather arbitrary and is based on the system under test.

If the acoustics of a large reverberant room are being analyzed, standing waves can cause wide fluctuation in amplitude. Tracing these rapid fluctuations requires a fast droop rate and hence a small capacitor. On the other hand, a fast droop rate will tend to track individual waveforms of a low-frequency signal. Therefore, to provide for difference response time requirements, S18 is provided to switch in a parallel capacitor, C616.

Also recall from the generator sections that there is a blanking mode that switches off the output of the audio generator at

the end of a sweep. The same trigger that switches off the output of the audio generator turns on Q601, which rapidly discharges the capacitor at the input of IC606. Therefore, a clean cutoff is provided at the end of a plot.

The same signal that is applied to the peak detector is also applied to IC607. This is a true RMS-to-DC converter. Capacitor C617 controls the amount of filtering of the DC output. Unlike the peak detector, the response of IC607 is equal regarding both increasing and decreasing signal levels. Again S18 provides for a variable response time by adding C618 in parallel. Also the blanking trigger turns on Q602 to rapidly zero the output at the end of a sweep.

IC607 is a linear-to-log converter. Voltage gain in dB is defined as 20 times the log of the linear voltage gain. There is a linear voltage at S19 that is zero for a zero level input and ranges up to 4 volts for either a 4-volt peak or RMS input. Since a true log function cannot be physically implemented because it is of infinite length, a decision must be made to use only part of the function and eliminate the region that extends below some practical limit.

To help select an appropriate range; note the effect of a log converter on a linear input signal. Input variations slightly above zero produce very large output variations. Therefore, such things as ripple from the peak detector would be greatly magnified at low levels. Eliminating the lower portion of the function

produces a dead zone, for any input voltage below the cutoff point is ignored. The cutoff-point trade off is between low-level excessive sensitivity and total dynamic range, which is the remaining portion of the function. Thus, it was rather arbitrarily decided to cut off the function at minus 40 dB.

VOLTMETER PARTS LIST

Resistors, $\frac{1}{4}$ watt, 5% or better

R601, R603, R617, R641—1000 ohms
R604, R620, R622, R625, R631, R633, R634, R640—50,000 ohms, trimmer
R605, R624—15,000 ohms
R606-R608—30,000 ohms, $\frac{1}{4}$ watt, 1%
R607, R609—10,000 ohms, $\frac{1}{4}$ watt, 1%
R610—768,000 ohms, $\frac{1}{4}$ watt, 1%
R612—48,000 ohms, $\frac{1}{4}$ watt, 1%
R613—12,000 ohms, $\frac{1}{4}$ watt, 1%
R614—3000 ohms, $\frac{1}{4}$ watt, 1%
R615—1000 ohms, $\frac{1}{4}$ watt, 1%
R616, R628, R629, R632, R637, R638—10,000 ohms, $\frac{1}{2}$ watt
R618, R621—30,000 ohms
R623, R627—1 megohm
R616—100,000 ohms
R630—820 ohms
R635, R636—1000 ohms, trimmer
R639—330,000 ohms
R642—2200 ohms
R643—1500 ohms

Capacitors

C601, C602, C613, C614—5 pF disc ceramic
C603—0.1 μ F disc ceramic
C604—5—15 pF trimmer
C605—7—40 pF trimmer
C606, C608—100—400 pF trimmer
C607—680 pF disc ceramic
C609—.005 μ F disc ceramic
C610—100 μ F electrolytic, 16 volts or higher
C611, C612—33 μ F, electrolytic, 16 volts or higher
C615—.001 μ F disc ceramic
C616—.01 μ F disc ceramic
C617—2.2 μ F electrolytic or tantalum
C618—22 μ F electrolytic, 16 volts or higher
C619-C622—10 μ F electrolytic, 16 volts or higher
C623—10 pF disc ceramic
C624—2.5—10 pF disc ceramic
C625—100 pF disc ceramic
C626—10 pF disc ceramic

Semiconductors

IC601, IC602, IC605—748
IC603, IC604, IC610—318
IC606—LH0091 (National)
IC607—8048 (Intersil)
IC608, IC609—741
D601-D604—1N4001
D609-D611—1N4148
Q601, Q602—TIS97

Miscellaneous

S15, S18—DPDT toggle switch
S16—SP3-position toggle switch
S17—SP10-position rotary switch
S19, S20—SPDT toggle switch
J6—3-terminal microphone connector
J7—BNC connector
M601—1-mA DC meter
OV601—LA10 overvoltage limiter (MCG Electronics)
F601—0.5-amp fuse

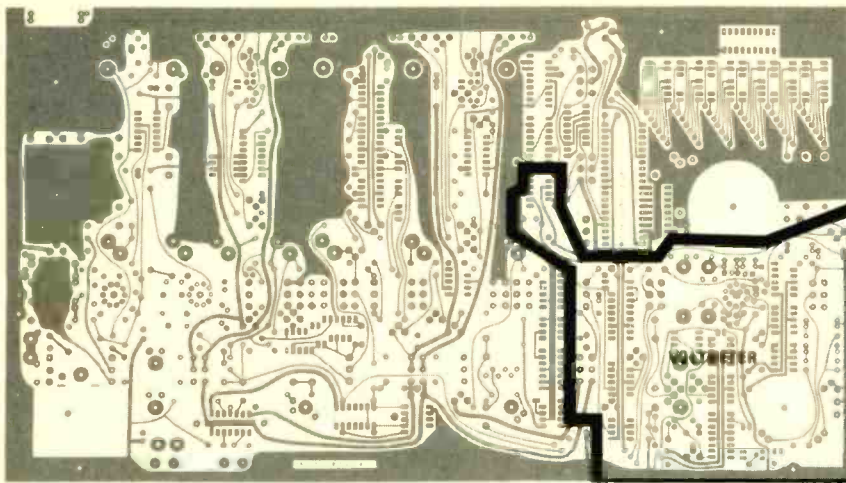

FIG. 11—FOIL PATTERN of the component side of the PC board overlaid with outlines of the area occupied by the voltmeter. The figure below shows the parts that are installed in this area.

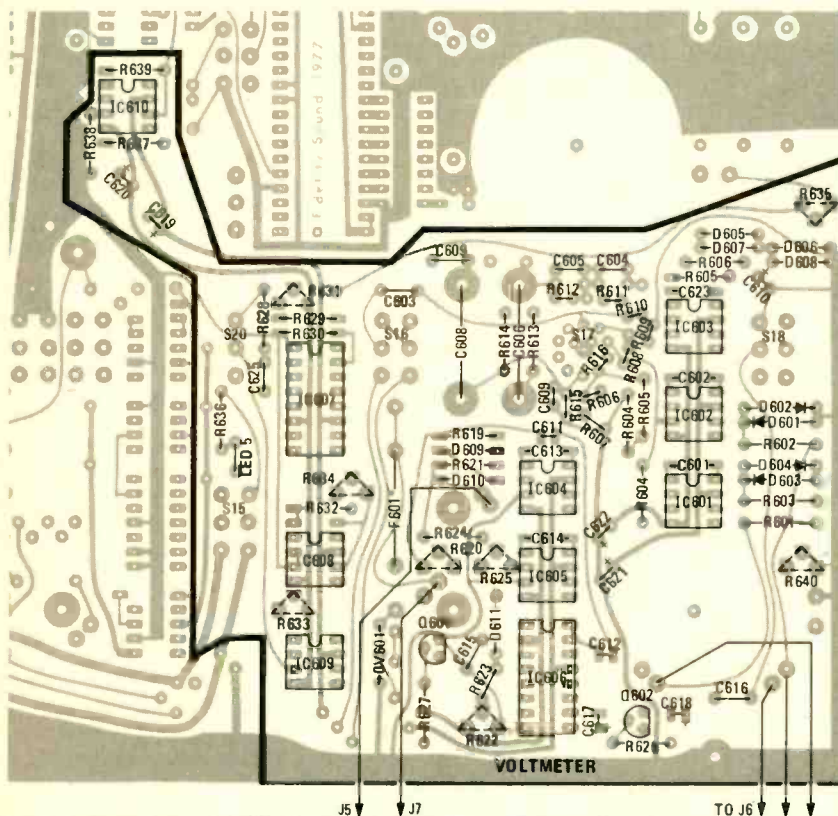

FIG. 12—COMPONENT LAYOUT diagram for the voltmeter. Parts used in this section are coded with numbers in the 600 series. See Fig. 10 for the schematic diagram.

The next task is to physically eliminate the lower portion of the function. To accomplish this, R631 applies a negative voltage to the inverting input of the output stage of IC607. This drives the log waveform up against a positive supply rail, which limits the transition or deflection. IC608 and its associated components provide proper polarity as well as gain and zero set.

Switch S20 selects the log signal, which was just described, or the linear signal, which is simply a bypass of the log converter. Resistor R635 converts the voltage signal to a current signal to drive the meter. A one-milliamp movement is quite satisfactory. Since audio measurements can sometimes be quite dynamic, it is preferable that the movement be critically damped.

IC609 is a very low-impedance output buffer. When connected in this manner, the impedance, looking back into the device, is that of the negative input, which is a virtual ground. IC609 is not really necessary but it does provide lower output impedance, isolation of the signal to the meter and better output protection than the circuit would have without it.

Overvoltage limiter OV601 limits the effect of the application of an external voltage; the same type optional unit is recommended here as was recommended for the other sections. Fuse F601 protects the overvoltage protector from excessive dissipation.

Assembly of this section is straightforward. Figure 11 shows the location of the voltmeter section with respect to the entire PC board and Fig. 12 shows the

location of the components.

Counter section

The schematic diagram of the frequency counter is shown in Fig. 13. Section b of S21 is the counter power switch; switch S21-a selects the signal to be counted. In one position the counter counts whatever signal is applied to the voltmeter. The voltmeter signal, however, can possibly be very low amplitude or altered in some way by the system under test so that it does not provide true and stable triggering of the counter. Therefore, S21-b can alternately select an internal signal from the audio sweep generator section. Stable counting of the sweep generator signal is thus always assured regardless of what happens to that signal as it is processed by the system under test.

The counter timebase establishes the counting period or window. The counting circuit counts each cycle of the input waveform that occurs during the time the window is open. If the counting window is 1 second, the total number of cycles counted is the average frequency of the input signal during that second in Hz.

This system uses both 1-second and 1/2-second counting windows. The one-half second window is more useful for tracking a swept frequency.

The timebase, which establishes a counting window, is derived from the power line and selected by switch S22. Resistor R702 is a pull-down resistor for the input of counter IC702. With pin 11 connected to ground, IC702 divides by 60. With pin 11 connected to V+ (which for the counter section is 12V), it divides by 50. On the circuit board, pin 11 is connected to ground. To convert the unit to a 50-cycle power line, it is only necessary to cut a circuit on the back side of the board and install a short bus wire jumper between two pads, which are provided for this purpose. Cutting the circuit disconnects pin 11 from ground. Adding the jumper connects pin 11 to V+. The output of IC702 then is a pulse train whose frequency is either 1 or 2 times the power-line frequency.

IC703 is a dual one-shot. For each input pulse, IC703 provides a negative going store pulse. This store pulse is about 10- μ s wide. This time is determined by C703 and R703. As the store pulse terminates, it triggers the second one-shot, which produces a positive going clear pulse. The width of the clear pulse is determined by C704 and R704 and is also about 10 μ s. The counting window then is from the end of the clear pulse to the beginning of the next store pulse. These two pulses shorten the counting window by about 25 μ s, inducing an error of 25 parts-per-million for a one-second update time or 50 parts-per-million for a half-second update. This error is insignificant in comparison to the normal power-line frequency variation. Line frequency er-

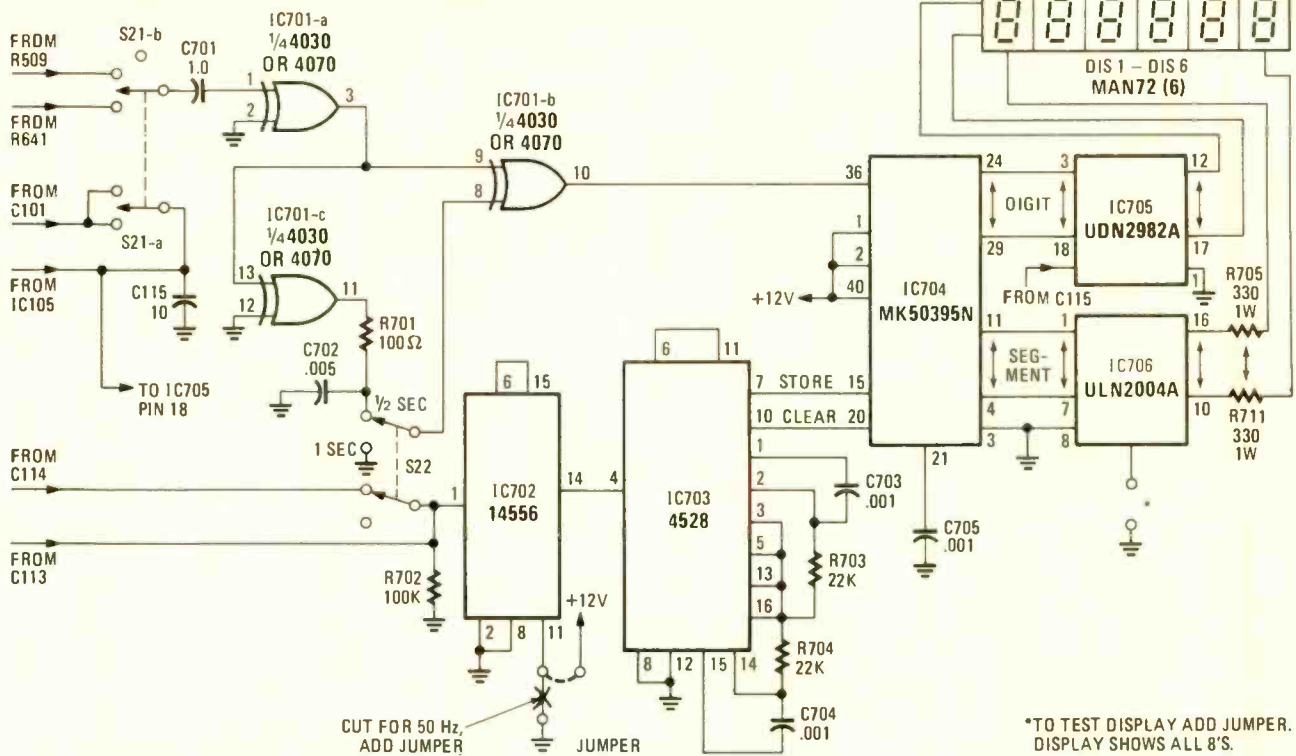

*TO TEST DISPLAY ADD JUMPER. DISPLAY SHOWS ALL 8'S.

FIG. 13 (above)—THE SCHEMATIC of the digital frequency meter. FIG. 14 (left)—THE AREA OCCUPIED BY the frequency meter. FIG. 15 (lower left)—LAYOUT OF PARTS in the frequency counter. IC105 at top center is a voltage regulator that is a part of the power supply.

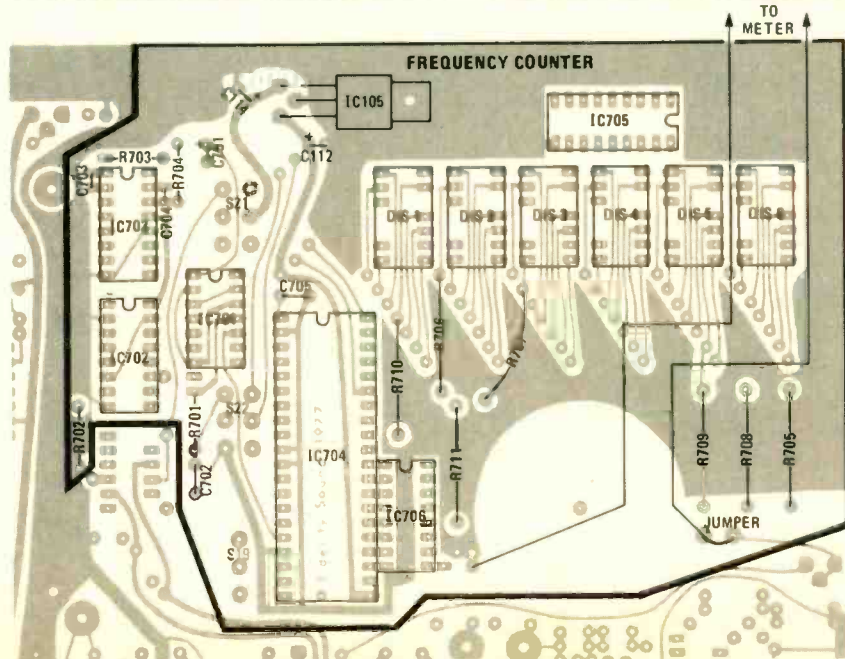
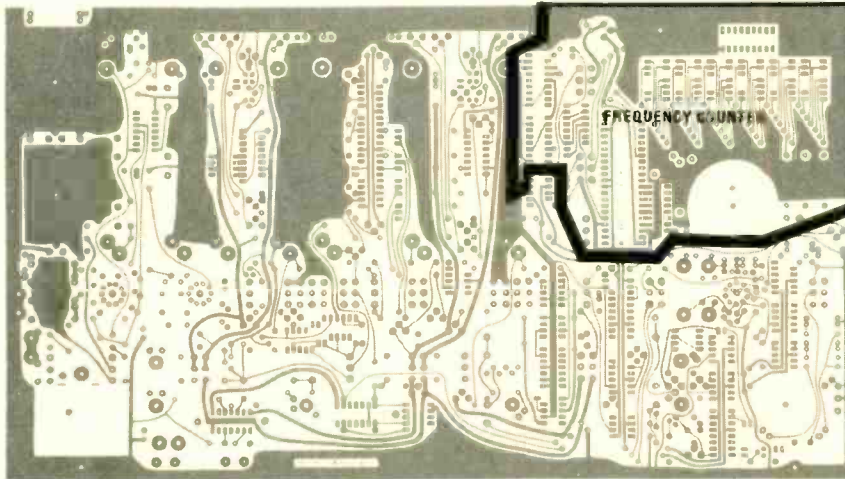

COUNTER PARTS LIST

- R701—100 ohms, ¼ watt, 5% or better
- R702—100,000 ohms, ¼ watt, 5% or better
- R703, R704—22,000 ohms, ¼ watt, 5% or better
- R705—R711—330 ohms, 1 watt, 5% or better
- C701—1 μ F electrolytic, 16 volts or higher
- C702—.005 μ F disc ceramic
- C703—C705—.001 μ F disc ceramic
- IC701—4030 or 4070
- IC702—4566
- IC703—4528
- IC704—MK50395
- IC705—UDN2982 (Sprague)
- IC706—ULN2004 (Sprague)
- DIS1-DIS6—MAN72 7-segment display
- S21—DP3-position toggle switch
- S22—DPDT toggle switch

The following are available from FSI, 1894 Commercenter W., No. 105, San Bernardino, CA 92408: Complete Kit, \$495.00; cabinet and circuit board, \$115.00. Set of semiconductors, \$195.00; seven slide pots with knobs, \$17.00, set of trimmers including four multitrans, \$17.00.

California residents add state and local taxes as applicable.

rors are a fraction of a percent. The overall result is a timebase-caused error in the fourth or fifth significant figure of the displayed frequency.

IC701 is a quad exclusive OR gate connected as a frequency doubler. Gate
continued on page 105

TROUBLESHOOTING CB Receivers

The receiver circuits in Citizens band transceivers can develop defects that affect range and performance. Here's a look at basic circuits and suitable test equipment.

FOREST BELT

THE SIGNALS NEEDED FOR CB RECEIVER servicing are not drastically different from those for FM two-way radios. Yet, because they are simpler, CB signal generators typically cost less than those designed for FM communications. Citizens band involves only a limited range of VHF signals—from 26.965 MHz to 27.405 MHz. You need IF (or high-IF) signals, usually, from 4 MHz to 12 MHz. Certain noise blankers take 21-MHz, 23-MHz and 25-MHz signals for correct alignment. And of course there's the 455-kHz IF that seems standard almost everywhere.

A CB generator uses AM modulation; and that's easy. However, there is one tricky concern: checking out the single-sideband function of AM/SSB receivers. Ordinary amplitude modulation doesn't suffice for that job. So, for SSB tests, you'll want your CB generator to have a *frequency-offset* feature. Various generators include this capability, but in different formats.

Basically, an overall alignment procedure follows the pattern for other communications receivers. There's no demodulator calibration for AM, nor any limiter stages. The first steps in an alignment procedure takes care of the 455-kHz IF stages.

The AM detector is a good—and usually convenient—place to connect your DC voltmeter as an alignment indicator. As the signal reaches the AM detector, the diode (or diodes) develops (by rectification) a DC component that is proportional to the carrier strength. This is often

the same DC voltage used for the automatic gain control (AGC) of RF and IF stages, and in many CB receivers to control the squelch system.

Find the AM detector. Three common versions are shown in Fig. 1. Identify the detector output side on the circuit board; usually it's at the anode end of the series diode. This orientation makes the rectified DC negative with respect to ground. So the negative or black lead of your DC voltmeter clips to the detector output. The other (red) voltmeter lead goes to the negative power bus (note—only in a few chassis is this bus the same as chassis ground). If the diodes are wired with the cathode to the output side (Fig. 1-c), you'll have to reverse the voltmeter leads.

If a receiver has an S-meter, you can usually depend on it as an alignment indi-

cator. Just make sure (using the schematic as a guide) that the S-meter senses signal strength *after* the last IF stage and not before. A few S-meters are driven directly by the AM detector or by a DC-driven AGC system; either of these systems is OK for alignment.

Set the signal generator for 455 kHz. Although accuracy is not so critical as for FM demodulator alignment; the frequency should be relatively close. And it must be stable—free of any significant drift. If you have any doubts, monitor the generator output with a frequency counter.

Feed the 455-kHz signal into the base of the mixer transistor just preceding the 455-kHz IF stages. Turn up the generator output just enough to show a noticeable DC meter reading at the AM detector. Do not turn it high enough to flatten out the indication. That is, if more input

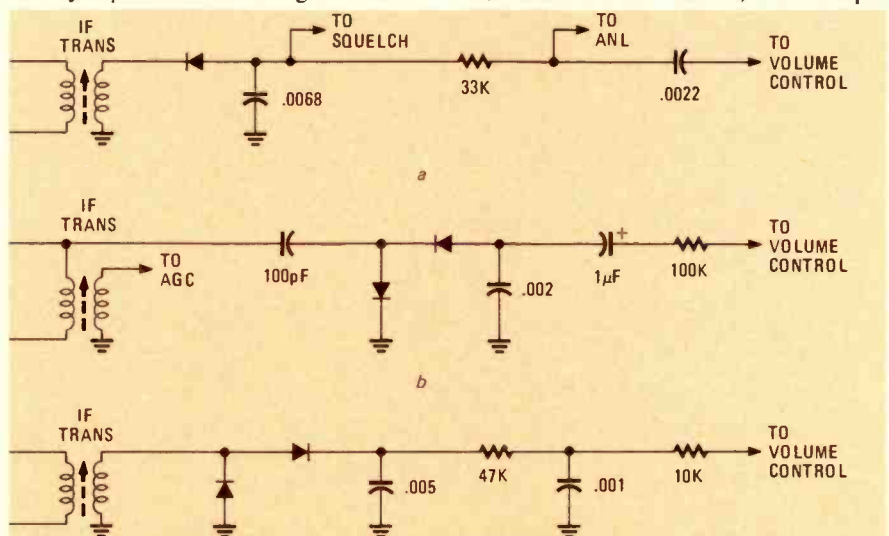
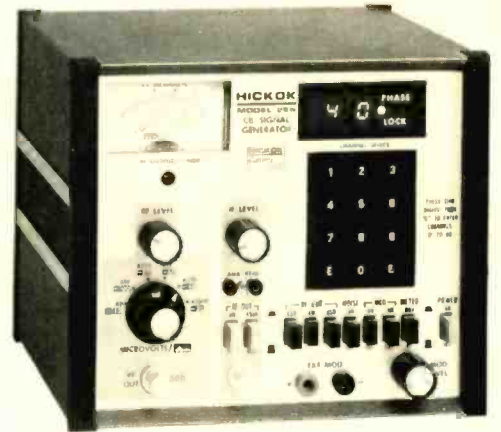

FIG. 1—MOST AM DETECTORS have diodes oriented for negative-going input, as shown in a and b. A few doubler detectors have diodes wired so that output is positive-going as in c.



SENCORE MODEL CB42



HICKOK MODEL 266



LEADER MODEL LSG-227

signal causes hardly any additional meter deflection, you've turned the generator output level too high.

Now adjust the mixer output coils and the 455-kHz IF transformers for a maximum DC reading. Where any core adjustment does not show a sharp peak, suspect trouble. The most likely culprits are: (1) a generator set for too much output; (2) a defective coil or slug; (3) an open decoupling capacitor for that winding; or (4) too much leakage from a transistor junction either before or after that coil. The cure for each should be obvious.

High-IF section

Some CB receivers do not have a 455-kHz IF. They use only one single-conversion mixer. The IF is in the megahertz

range, just as it would be for a double-conversion mixer. In this case, however, the high-IF signal feeds the AM detector directly.

This design is most often found in AM/SSB receivers. The block diagram of Fig. 2 shows why. Signal insertion for SSB demodulation takes place at the same frequency used for SSB signal generation in the transmitter, so that the same oscillator is used. Hence, the receiver high-IF is chosen to match.

During AM operation, the same IF signal feeds an AM detector, with no need to heterodyne down to 455 kHz. The main advantage of the second conversion, which would be useless during SSB reception anyway, would be greater AM selectivity. However, today's crystal filters for high-IF stages have very steep skirts. Further bandwidth filtering is not absolutely necessary. A designer can

choose an exceptionally sharp-sided high-IF filter, and get by without the extra mixer and extra IF section.

If you're dealing with a single-conversion receiver that has only the high-IF section, alignment procedure starts the same as for low-IF: Clip your DC voltmeter to the AM detector. (Never try to align in the SSB mode.) Feed the base of the mixer transistor with an accurate high-IF signal. Common frequencies are 7.8 MHz, 10.7 MHz and 12 MHz. Check the schematic or the service notes for the set you are aligning. The high-IF filter may have the frequency stamped on it. (This filter often does double duty as the SSB filter.)

Adjust the generator output as already described—enough for a DC reading at the AM detector, but not enough to saturate the RF or IF stages. Peak all the mixer and IF adjustments. As a troubleshooting aid, note any adjustments that peak too broadly.

In double-conversion sets, align the high-IF section after making sure the low-IF stages are OK. However, first verify that the second receive oscillator feeds the right frequency to the second mixer. The schematic usually gives the crystal frequency, but not always to fine enough accuracy. For example, a 7.8-MHz high-IF requires a 7.345-MHz crystal in the second conversion oscillator. The diagram could indicate only a 7.3-MHz frequency. Use your knowledge of heterodyning and a calculator to determine the exact frequency. Then, using your frequency counter, measure this frequency at the output of the oscillator.

You can use an alternative approach if your signal generator has digital dial-up accuracy. Use the high-accuracy generator for the 455-kHz alignment, as already described. Then, without changing the feed point, move the generator frequency to the high-IF. Keeping an eye on the DC voltmeter, raise and lower the frequency in 100-hertz steps. The highest DC voltmeter reading should coincide exactly with the high-IF design frequency.

If it doesn't, the crystal probably has

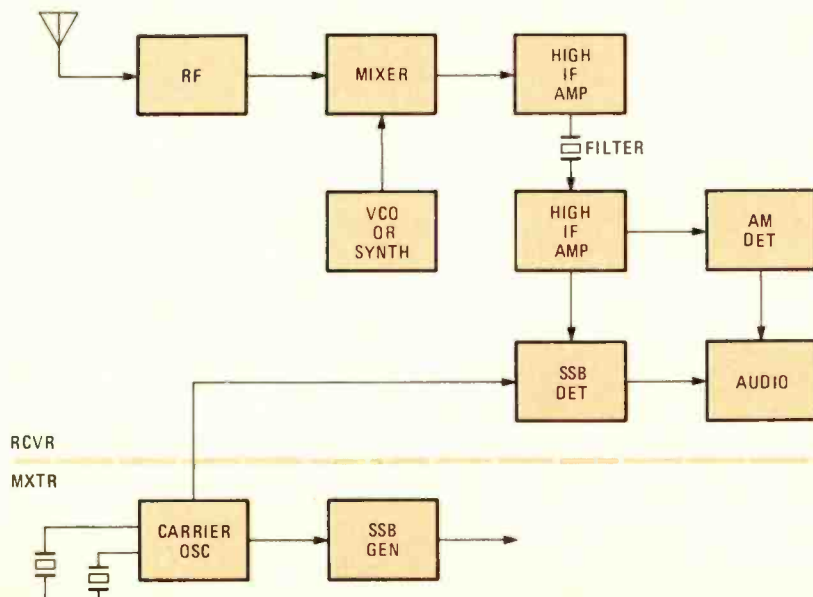

FIG. 2—MANY SSB RECEIVERS for CB convert (mix) only once, to the high intermediate frequency. Crystal or ceramic filter provides selectivity.

TABLE 1—CB SIGNAL GENERATORS

Mfr Brand	Model	Output (mV)	Accuracy (ppm) ¹	PLL	SSB offset	IF Signals		EIA NB test
						Low (kHz)	High (MHz)	
B&K/ Precislon	2040	100	5	✓	Var	455	—	Yes
Com-Ser ²	CB-2700 ²	1	5	✓	—	30 up	to 12	No
Hickok	266	100	5	✓	± 1 kHz	455	1-20 ³	Yes
Leader	LSG-227	100	5	✓	Var & ± 1 kHz	455	—	Yes
Logi-Metrics	981 ²	20	2		—	—	—	No
Sencore	CB42 ²	100	5	✓	± 1 kHz	375 up	to 12	No
Time & Frequency Technology	767	300	5		Digital	100 up	to 12	Yes

Note: Var = Variable.

1. ppm = parts per million. 5 ppm equals 0.00005 percent.

2. Has features in addition to signal generator.

3. Needs external crystal for each high-IF frequency.

shifted frequency. The second oscillator circuit may contain a frequency adjustment, but many do not. A shift in frequency of more than 300 Hz from the center can degrade reception enough to justify replacing the crystal. Besides, the error will only grow worse.

A quick trick

The crystal-controlled nature of a CB receiver offers an excellent opportunity to save some alignment time. This time-saving procedure works best for single-conversion, whether the IF is 455 kHz or several megahertz. It also—usually—works OK for double-conversion, if you follow the procedure carefully.

You need a highly accurate signal generator, any of the phase-locked models (see Table 1) will have sufficient accuracy and stability. Once you're familiar with the CB models you work on most, you may like this shortcut.

Follow the procedure shown in the block diagram of Fig. 3. Coils have been added to show the adjustments you may encounter; some sets have fewer, some have more.

First thing you do is jump in with your frequency counter and verify the frequencies generated by the phase-locked loop (PLL) (or use a frequency synthesizer if the CB is an older model). Keep the transceiver's RF input connected to a dummy load during these measurements. This is to avoid any stray inputs that might confuse the frequency counter. A test point is usually provided for the counter near the mixer input. Check all channels.

Next, measure the frequency of the receive oscillator. It may be adjustable, so you can set the frequency precisely. If the set is a single-sideband model, look for another oscillator or two in the same vicinity. Set these oscillators while you're at it. A test point or test points nearby accommodate the frequency counter. Certain elaborate CB models have three or four oscillators, for various modes. Measure the frequencies of them all, switching to the appropriate modes of transceiver operation. Correct any that are adjustable. Install a new crystal anywhere the error exceeds a couple of hundred kilohertz.

Feed an accurate generator signal right into the front end (remove the dummy load). Set the generator for Channel 21. (Use Channel 13 in 23-channel sets.) No modulation is needed from the generator. Connect your DC voltmeter at the AM detector, as already described. Set the receiver for Channel 21, and select the AM mode. Turn up the generator output so that a reading is obtained on the meter.

Since you've already determined that all conversion oscillators and the phase-locked loop (or synthesizer) are on-frequency, you can now peak all the IF and RF adjustments for maximum DC at the AM detector. If the reading goes too high with the peaks too broad, reduce the generator output somewhat.

The beauty of this procedure, once you know where to find the oscillator and PLL (or synthesizer) test points, is its simplicity and speed. It is also *thorough*. If there's a problem in the oscillator or the PLL, it appears during your frequency-counter tests. (Note—of course, the frequency counter must have enough sensitivity to measure oscillators directly. Oscillators in CB sets usually have an output range from 20 mV to 50 mV RMS.)

You complete RF and IF alignment both with one connection of your signal generator, which saves time. And, naturally, any weaknesses or oscillations in those stages become evident as you adjust.

Unwanted oscillations in the RF or IF stages appear generally as an uncontrollably high DC reading at the AM detector. Often, this appears as you peak an adjustment, and is usually because somebody detuned the stages to cure the squawk or distortion. The true cure is substituting a new decoupling capacitor, a new coil assembly, or (rarely) a transistor with less inter-element capacitance.

Selectivity filters

You can check the bandwidth filters in CB sets in much the same way as in FM

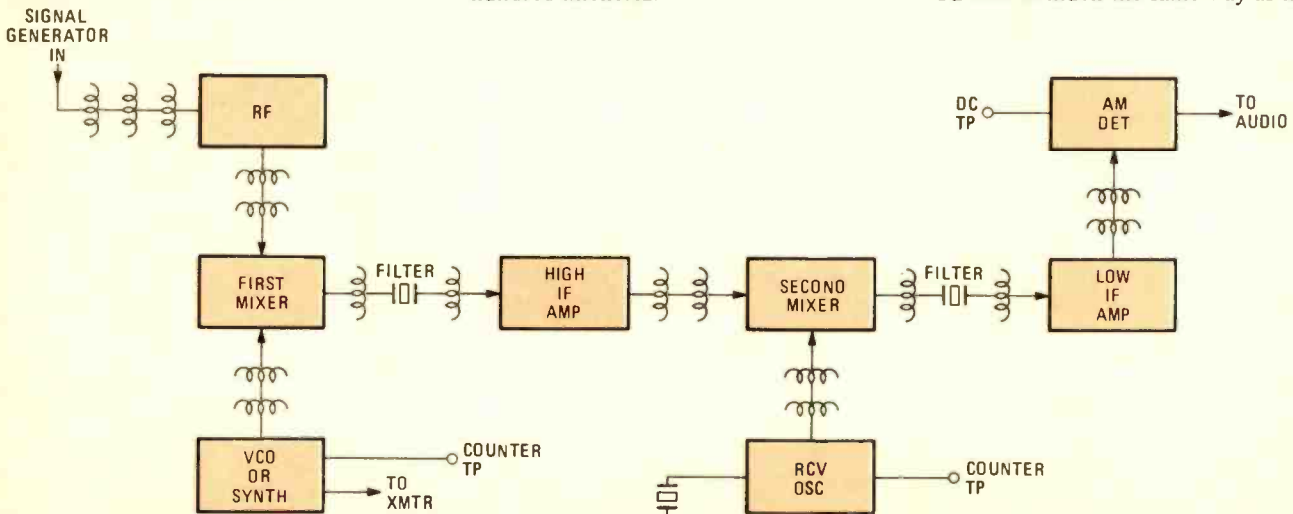

FIG. 3—CHECK OSCILLATORS FIRST with a frequency counter, and you can align with an accurate RF signal fed into the front end.

two-way receivers. But there is a handier evaluation, using the same test setup as for RF alignment.

The generator signal feeds into the antenna jack. The receiver and generator both operate on Channel 21 (or Channel 13). Keep the DC voltmeter at the detector output. However, here are two differences: Turn the generator output up to 50,000 μV , and add 30 percent modulation. Yes, the RF and IF stages will be saturated, the AGC will be fully operative, and the DC meter reading will be at its peak. Set the volume for comfortable listening.

Leaving the receiver set to Channel 21, change the generator frequency to Channel 20, which is 27.205 MHz. You'll note a drastic reduction in sound from the speaker, and in the DC meter reading. Turn up the volume enough to hear *some* sound, even if it's just noise with very little demodulated sound. Adjust the generator output, if there's enough, for a measurable DC meter reading.

Next, switch the generator frequency to Channel 22, or 27.225 MHz. The DC meter reading and the recovered sound should be the same as they were when you fed in Channel 20. If there is much difference, the alignment is faulty or the filter is off-center. Since a complete alignment procedure was performed before you made this test and you made sure all coils peak properly, the defect is likely to be in the filter.

You probably recognize what you're doing in this quick test—assessing *adjacent-channel rejection*. You can measure actual decibels of rejection. This test gives only an approximation. In a properly operating CB receiver, sound recovered under adjacent-channel conditions should drop to weak sound with some noise in the speaker. That signal drop represents about 50 dB of rejection, which is roughly equivalent to reducing the generator signal from 50 mV to 0.5 μV (on-channel).

Measuring adjacent-channel rejection takes only enough (or more) time to connect an audio voltmeter across the speaker. Set the generator to Channel 21, the output to 1 μV and modulation to 30 percent. Set the receiver to Channel 21, and adjust the volume control to give an audio output of 1.5 volts RMS. That's your reference audio level.

Switch the generator to Channel 20. Increase the generator RF signal, in decade steps, until the audio output meter again reads 1.5 volts RMS or close to it. Each RF increase by a factor of 10 represents 10 dB of adjacent-channel rejection. For example, if the adjacent-channel audio output comes up to 1.5 volts RMS again when the RF signal from the generator is increased from 1 μV to 1000 μV , the adjacent-channel rejection is 30 dB. If it takes 10,000 μV , the rejection is 40 dB. A 100,000- μV signal means 50 dB of rejection. The average modern CB receiver

shows a rejection of 40 dB or so.

With this approach, you can assume the selectivity filter is faulty if (1) adjacent-channel rejection is less than 20 dB, or (2) if rejection values above and below the receiver channel are more than 10 dB apart. This judgment presumes that you have finished troubleshooting and aligning the RF and IF sections before testing adjacent-channel rejection.

The cure for a faulty filter is usually a new filter. If adjacent-channel rejection is balanced but poor, check carefully the input and output loading of the suspected filter. This includes the transistor preceding the filter and following it, plus the decoupling capacitors in the base or collector circuits of those transistors. New filters are somewhat expensive in some models, so you want to be as sure as you can.

Noise blankers

Manufacturers of specialized CB generators seem to have overlooked noise-blanker adjustments. They provide no signal for aligning the RF input coils. Inexpensive CB receivers of course have no noise blanker to consider. Some blankers sense pulse noise *after* the first mixer; any input coils tune to the high-IF. Others have untuned inputs, but several still incorporate a system similar to the one shown by the block diagram of Fig. 4, in which the coils are included to indicate their positions. An IC chip contains most of the blanker stages in newer CB receivers.

For alignment purposes, what concerns you mainly are the input coils. In Fig. 4, these coils are shown to peak at 21 MHz. However, some set designers choose 23 MHz or 25 MHz. A significant part of the objective is rejection of 27-MHz signals. But the blanker system needs the gain these stages afford at their own RF frequencies. This gain assures efficient

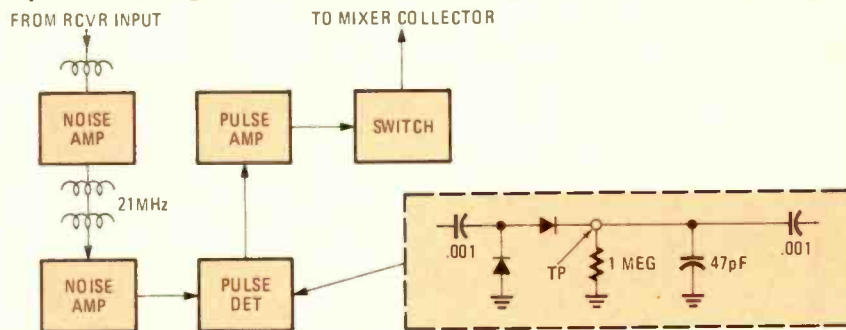

FIG. 4—MANY NOISE BLANKERS do not have tuned circuits; those that do should be aligned properly for optimum performance.

pick-up of ignition-noise pulses, because automotive-noise RF energy is strong in the 20–30-MHz frequency range.

In the absence of noise pulses, such as when an unmodulated RF test signal is used, the pulse-detector diode acts similar to an AM detector. That is, it produces a DC voltage that is proportional to RF signal strength.

Connect your DC voltmeter at the

diode output; an IC usually has a test point for this connection. Feed just enough signal into the antenna jack (at the listed blanker-coil frequency) to cause a meter reading, and peak the RF coils.

That's all there is to it. Accuracy isn't critical, but you use a stable signal source because even small frequency changes could lead to a broadening of blanker response.

SSB tests

When you've aligned and tested a CB receiver for AM operation, you've already covered almost everything in the RF and IF stages that could interfere with SSB reception. Any symptom present in SSB only indicates a demodulator or mode-switching fault. The SSB demodulator normally is the same circuit as the SSB modulator. Servicing it as a transmit function proves easier than troubleshooting its receive function. So, if the complaint is an SSB "receive-only" symptom, mode-switching seems about all that's left.

To corroborate your evaluations of receiver operation after you've finished all AM alignment and assessment, you can test SSB reception with your CB signal generator. Here's the way to do it, quick and easy if your generator has the right controls.

What does "right controls" mean? It means you must be able to offset the channel carrier by 1 kHz (1000 Hz), accurately. You see this easiest in a generator with digital frequency knobs. For example, for CB Channel 21 at 27.215 MHz, the frequency reading on a 500-MHz signal generator that has a 7-digit dial would be 027.2150 MHz. To raise the frequency (the upper sideband) by 1 kHz, change the dial to read 027.2160 MHz. For the lower sideband, set the dial at 027.2140 MHz. Use no

modulation, just RF.

Set the receiver for AM at first. With the generator frequency set to channel center (027.2150 MHz), you should hear no sound in the speaker. Set the receiver for LSB operation, and set the signal generator for 027.2140 MHz. You should hear a 1000-Hz tone, and a frequency counter across the speaker should

continued on page 79

communications corner

A new monthly column devoted to the latest developments in the communications field.

HERB FRIEDMAN, COMMUNICATIONS EDITOR

WELCOME TO "COMMUNICATIONS CORNER," a new monthly column devoted exclusively to the latest developments in the field of communications as they affect CB, SWL, VHF/UHF radio, amateur radio—and whatever else comes along as a result of new technologies.

Just a few short years ago, each of these individual branches in the field of communications would have been considered separately and covered by separate articles and feature stories. But because of the "crossover" factor, whereby a modern technological development for one branch finds instant application to other branches under the umbrella labelled "communications," a better picture of what's happening today and what will happen tomorrow is attained by combining all aspects of consumer communications into a single column.

We will try to describe not only the latest developments in general and specific communications, but how they are actually applied to the various pieces of equipment the average consumer, hobbyist and technician will find.

In many instances, we will introduce you to the "leading edge of the state of the art," although this leading edge could often be nothing more than a 30-year-old idea updated with modern devices, (such as the substitution of transistors for vacuum tubes). We plan (with cooperation from the manufacturers) to introduce you to new uses for old ideas, old uses for new ideas, and, of course, new uses for new ideas as they affect the world of communications.

To give you an idea of what to expect in future months, we're now going to touch all the bases with some of the very latest developments in all fields of consumer communications. Later columns will go into the nitty-gritty of individual circuits.

Computerized CB

Heading the list in terms of interest (or at least my own interest) is computerized CB transceivers. We've all been hearing about computerized CB for at least the past 12 months. Originally, the BIG NEWS was that "the biggie" company in

computers and calculators was on the verge of introducing a computerized CB. Many months (and a poor year for sales) later, the "biggie" has yet to introduce their model; but computerized CB has now been introduced by Robyn and Pathcom (among others), with more to follow.

Actually, the computerization of CB is really receiver-oriented. There are variations, of course, but the basic idea is a microprocessor that permits the user to program a specific group of channels to be scanned for activity (busy channel) or lack of activity (clear channel). Alternately, the computer can be programmed to scan all channels, or it could be programmed for operation on one channel with frequent checks of an alternate channel. (For example, Pathcom's *Pace 8117* can be programmed to monitor a second channel once every 10 seconds for 1/2 second.)

While you cannot scan with the transmitter keyed, the transmitter usually follows the receiver in a computerized transceiver; so if the receiver stops on a channel during a scan, the transmitter is similarly tuned to the same channel. One main feature of the computer is that it



FIG. 1

prevents operation on unauthorized frequencies. For example, if you attempted to program the *Pace 8117* for Channel 51 or even a 3-digit channel, as for example Channel 123, the computer says "tilt" to itself and defaults to Channel 19.

The *Pace 8117*'s touch-pad, used for both channel entry and microprocessor programming, is shown in Fig. 1. This touch-pad is more or less typical of a computerized CB keyboard, and in later

columns we'll cover touch-pad programming.

VHF/UHF

For several years, the more expensive VHF/UHF scanning monitor radios have allowed the user to digitally program a group of desired frequencies. Although somewhat more expensive than crystal-controlled scanners, the programmable scanners permitted the user to easily follow the special services—in particular the police—as they moved around the public-service bands. Usually, it took a not-very-accurate frequency list or handbook and some local undercover work to discover where the local safety services were moving as they hopscotched around the low VHF (30—50 MHz), high VHF (146—174 MHz) UHF (450—500 MHz) and the "T" (Television—unassigned low UHF television channels) bands. But for every need there's an invention, and this year's is the "searching scanner." Microprocessor-controlled searching scanners, such as those manufactured by Radio Shack and Bearcat, allow you to program high- and low-frequency limits, which are then continuously scanned until an active frequency is located. Some of the more sophisticated models, such as the Bearcat *model 250*, keep a running count of each active frequency; and at the end of a given time period, you can read back total activity to determine which frequencies in your immediate locality are most used.

And, finally, there's a searching scanner for the aviation enthusiast, the Regency *model ACT-T-720A* Digital Flight Scan. This scanner covers airport and aviation frequencies from 108 MHz to 136 MHz. Like the VHF/UHF monitor radios, the *model ACT-T-720A* can be directly programmed to a desired frequency, or can be programmed to search a selected range of frequencies.

Amateur radio

After having spent many years in the doldrums in terms of both membership and equipment, amateur radio, the oldest of electronically oriented hobbies, has been given new life by modern technology. From new all-band VHF mobile antennas, to broadband-tuned transmitters and receivers, to an ever-expanding two-meter FM band, and, finally, to dig-

continued on page 74

**ALL
NEW**

Real-State-of-the-Art

TWO NEW AC•DC•BATTERY PORTABLE COUNTERS

OPTO-8000 .1A 10Hz to 600 MHz — FREQUENCY COUNTER

- Precision TCXO time base 0.1 PPM Stability 17-40°C
- Super Sensitivity with preamps in both HI-Z & 50 Ohm inputs <10mV to 50MHz, 25 mV @ 150 MHz <50mV to 600MHz
- Auto Decimal Point • Aluminum Case • Socketed IC's
- Three position attenuator: X1, X10, X100 (avoids false counting)

#OPTO-8000.1A	Factory Assembled	\$329.95
#OPTO-8000.1AK	Kit Form	\$279.95
#NI-CAD-80	NI-CAD Battery Pack	\$ 19.95

OPTO-7000 10 Hz to 600 MHz MINIATURE COUNTER

- XTAL (TCXO) Time Base ± 0.08 PPM/°C
 - Aluminum Case • HI-Z & 50 Ohm inputs
 - 1 Sec. & 1/10 Sec. Gate times • Auto Dec. Pt.
 - Built-in Prescaler and Preamps Standard
- | | | | |
|-------------|---------------------------------|-------|----------|
| #OPTO-7000 | Factory Assembled - 1 Year-Guar | .. | \$139.95 |
| #OPTO-7000K | Kit Form | | 99.95 |
| #AC-70 | AC Power Pack | | 4.95 |
| #NI-CAD-70 | NI-CAD Battery Pack | | 19.95 |
| #TCXO-70 | Precision TCXO Time Base | | |
| | <0.1PPM, 17-40°C | | 79.95 |

ACCESSORIES

PROBES:

#P-100	50 Ohm, 1X	\$13.95
#P-101	Lo-Pass	16.95
#P-102	H1-Z, 2X	16.95
# AP- 8015	UHF Counter Preamp 20 MHz to 600 MHz 15-50 DB Gain		
	(Not Shown) ..	\$49.95/Kit	\$39.95

#D-450 Antenna
Rubber Duck RF Pick-up 450 MHz ... \$12.50

#D-146 Same as above
146.5MHz \$12.50
#RA-BNC Right-Angle BNC Adapter for
above Antenna 2.95

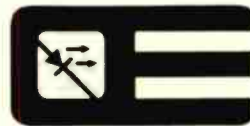
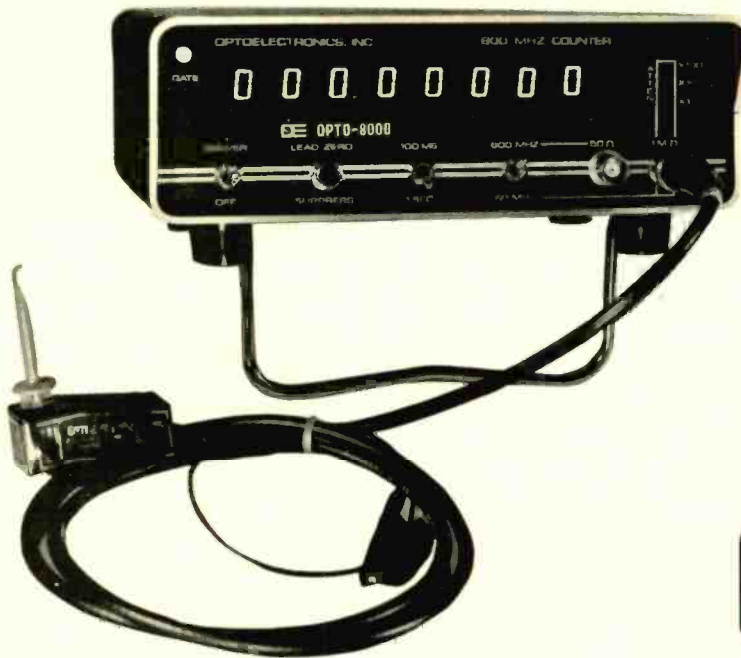

OPTOELECTRONICS, INC.

5821 NE 14 Avenue
Ft. Lauderdale, FL 33334
Phones: (305) 771-2050 771-2051

Phone orders accepted

ORDER FACTORY DIRECT — PHONE OR MAIL

TERMS: Orders to U.S. and Canada, add 5% to maximum of \$10.00 per order for shipping, handling and insurance. To all other countries, add 10% of total order. Florida residents add 4% state tax. C.O.D. fee: \$1.00. Personal checks must clear before merchandise is shipped.

Train with NTS for the MicroComputers, digital the first name



MicroComputers

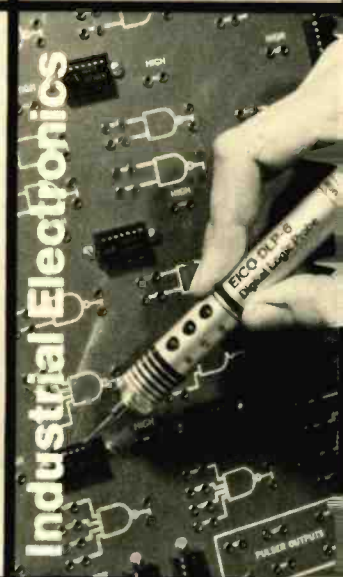

The world of electronics is daily becoming more challenging. Technology is growing more specialized, and the importance of digital systems increases every day. Test instruments, home entertainment units and industrial control systems are all going digital. And now, NTS training programs include a wider choice of solid-state and digital equipment than ever before offered in any home study course: Advanced NTS/Heath digital color TV (25" diagonal with optional programming capability), NTS/Heath microcomputer, digital test equipment, digital stereo receiver (70 watts per channel), NTS compu-trainer, plus much more state-of-the-art equipment to make your training exciting and relevant.

The equipment you receive with NTS training programs is selected to provide you with a solid

background in electronic systems. Kits and lessons are designed to work together to demonstrate electronic principles and applications. The kit-building not only shows you how electronic hardware functions, but how various circuit designs accomplish different purposes. Your lessons guide you through any number of experiments associated with many projects. This is the Project-Method, and it works. Step-by-step, you learn how and why digital electronics has become a part of our world, and the even bigger role it is sure to play in the future.

Whether you are looking for training in Consumer, Commercial, or Industrial electronics, NTS offers fourteen courses, some basic, many advanced, in several areas of electronics. An all-new full-color NTS catalog shows you what each course covers,

electronics of the future.

systems and more...from
in home study.



Test Instruments



Basic Electronics



Simulated TV Reception

Digital Color TV

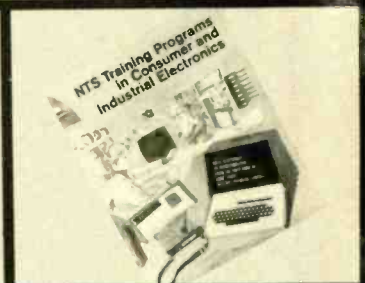
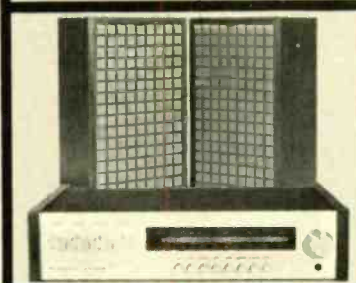

and every piece of equipment included.
Send for it today, and see for yourself what's really happening in electronics training technology at NTS. Find out how much has changed, and what new directions the field is taking. You'll probably want to be a part of it.
It's free. Just mail the card or coupon. Today.

**NO OBLIGATION. NO SALESMAN WILL CALL.
APPROVED FOR VETERAN TRAINING.**

NATIONAL TECHNICAL SCHOOLS

TECHNICAL-TRADE TRAINING SINCE 1905
Resident and Home-Study Schools
4000 South Figueroa St., Los Angeles, Calif. 90037

NATIONAL TECHNICAL SCHOOLS Dept. 206-059
4000 South Figueroa Street, Los Angeles, California 90037

Please send FREE Color Catalog and Sample Lesson.

- Color TV Servicing
- B & W TV and Radio Servicing
- FCC License Course
- Electronic Communications
- Electronics Technology
- Audio Electronics Servicing
- Digital Electronics
- MicroComputers/MicroProcessors

Name _____

Address _____

Apartment Number _____ Age _____

City _____

State _____ Zip _____

- Check if Interested in G.I. Bill information.
- Check if Interested ONLY In classroom training in Los Angeles.

COMMUNICATIONS CORNER
continued from page 68

tal readout and synthesis of VHF and UHF equipment, probably more technological excitement is going on in ham radio now than in all other electronic hobbies combined, other than personal computing. We'll cover many of the latest ham radio developments in detail in the coming months. Right now, let's look at digital-frequency readouts.

Digital readout

The price of a digital readout has decreased drastically. Everything from bathroom scales to set-back home ther-

mostats has a counter-driven digital readout. It's, therefore, not surprising that much of the recently introduced Ham gear also contains digital readouts. No more interpolating the position of cursors, or "in-between" 1-kHz calibrations, a digital readout now indicates precisely—usually by 100 Hz—the center frequency of a receiver or transmitter. Actually, the procedure isn't difficult since all it involves is a frequency counter connected to the local oscillator or VCO. An offset applied to the counter programs it to display the frequency directly, for example, 21.275.3 MHz. This is a lot easier than the digitally synthesized tuning (programmable frequency selection)

used in some gold-plated-special receivers.

We'll cover both digital readout and synthesized tuning in amateur gear in greater detail in future columns.

SWL

Finally, let's see what's happening in shortwave listening (SWL). For almost the entire history of broadcasting, SWL receiver dial calibration was a hit-or-miss affair. With very rare exceptions, the dial calibrations barely came near the correct frequency, let alone right on it.

Those SWL enthusiasts who were fortunate to know about the Barlow-Wadley receiver (and parted with several hundred dollars for it) were fortunate to end up with one of the very few noncommercial, nonmilitary receivers that could be preset to a frequency and actually be on the button when the power switch was turned on.

The Barlow-Wadley circuit is unique: It uses two VHF crystal-referenced oscillators—one fixed, the other variable. Because the operating frequency is around 50 MHz and because the reference frequency is 1 MHz, an unswitched tuning knob can step the tuning in quartz-referenced (drift-free), 1-MHz steps from almost 0 Hz to any desired frequency, usually 30 MHz. The output of the two oscillators (in the 1 MHz–3 MHz range, depending on design) is then tuned by a dial calibrated from 0–1 MHz in 1-kHz or 5-kHz increments. In short, this is a beautiful system with a drift-free dial calibration that provides accurate tuning on the first try.

The original Barlow-Wadley receiver was a small battery-portable unit that outperformed many of the "gold-plated boat anchors" we then called *communications receivers*.

If you wonder what a Barlow-Wadley circuit would be like using the latest digital readout, you can see for yourself at your local Radio Shack store in the form of the *DX-300* Quartz-Synthesized Communications Receiver (see front-view photograph Fig. 2).



FIG. 2

Using the Barlow-Wadley conversion format in a triple-conversion receiver, the *model DX-300* features a digital readout directly in MHz and kHz, to a 1-kHz dial accuracy. The rated frequency range

continued on page 76

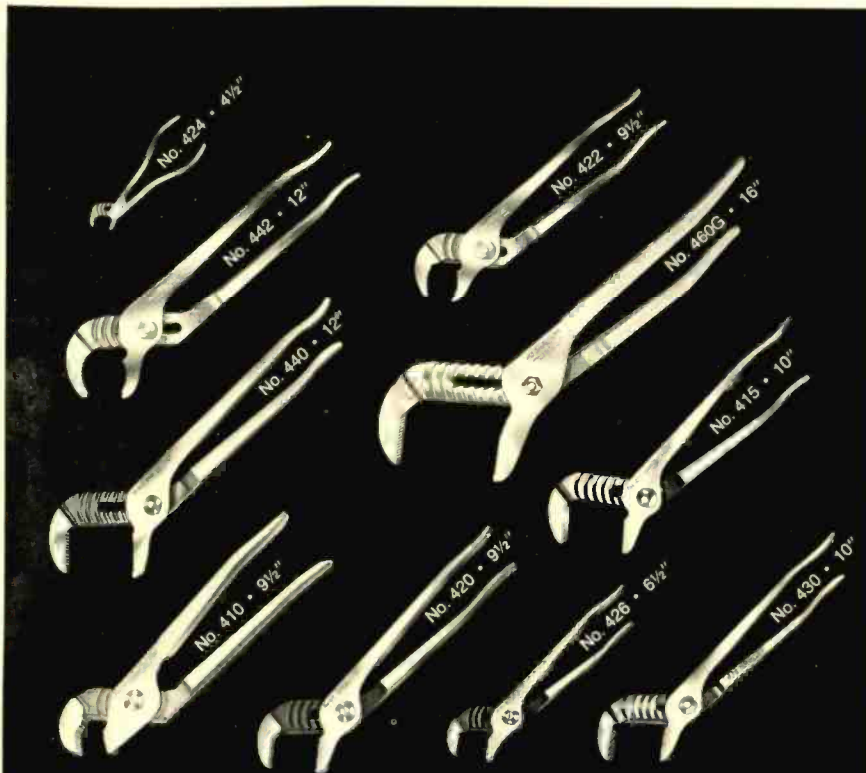

**Who Says Ours Are The Best?
YOU Do.**

Year after year, you tool users buy more CHANNELLOCK tongue and groove pliers than any of the imitator brands. By far. It's your way of telling us that CHANNELLOCK, the original, the first of its kind, is best of its kind. Thank you. We're going to keep it that way.

CHANNELLOCK, INC. • Meadville, Pennsylvania 16335

CHAN NEL LOCK

Meet the Rest of the Family. Send For Free Catalog.

CIRCLE 17 ON FREE INFORMATION CARD

Radio Shack: No. 1 Parts Place

Low Prices and New Items Everyday!

Top-quality devices, fully functional, carefully inspected. Guaranteed to meet all specifications, both electrically and mechanically. All are made by well-known American manufacturers, and all have to pass manufacturer's quality control procedures. These are not rejects, not fallouts, not seconds. In fact, there are none better on the market! Always count on Radio Shack for the finest quality electronic parts!

TTL and CMOS Logic ICs

Full-Spec Devices
Direct from
Motorola and
National Semiconductor



Type	Cat. No.	ONLY
7400	276-1801	35¢
7402	276-1811	39¢
7404	276-1802	35¢
7406	276-1821	49¢
7410	276-1807	39¢
7413	276-1815	79¢
7420	276-1809	39¢
7427	276-1823	49¢
7432	276-1824	49¢
7441	276-1804	99¢
7447	276-1805	99¢
7448	276-1816	99¢
7451	276-1825	39¢
7473	276-1803	49¢
7474	276-1818	49¢
7475	276-1806	79¢
7476	276-1813	59¢
7485	276-1826	1.19
7486	276-1827	49¢
7490	276-1808	79¢
7492	276-1819	69¢
74123	276-1817	99¢
74145	276-1828	1.19
74150	276-1829	1.39
74154	276-1834	1.29
74192	276-1831	1.19
74193	276-1820	1.19
74194	276-1832	1.19
74196	276-1833	1.29
4001	276-2401	49¢
4011	276-2411	49¢
4012	276-2412	69¢
4013	276-2413	89¢
4017	276-2417	1.49
4020	276-2420	1.49
4021	276-2421	1.49
4023	276-2423	69¢
4027	276-2427	89¢
4028	276-2428	1.29
4046	276-2446	1.69
4049	276-2449	69¢
4050	276-2450	69¢
4051	276-2451	1.49
4066	276-2466	99¢
4070	276-2470	69¢
4511	276-2477	1.69
4518	276-2490	1.49
4543	276-2491	1.89

SN-76477 Sound/Music Synthesizer IC



2.99 Featured in Oct. Popular Electronics

Creates almost any type of sound — music to "gunshots"! Built-in audio amp. Includes 2 VCO's, LF osc., noise gen., filter, 2 mixers, envelope modulator, logic circuit. 28-pin DIP. With data/applications circuits. 276-1765 2.99

Analog Audio Delay IC MN 3002

10.95



For Phase-Shifter, Reverb & Delay Circuits

"Bucket Brigade" device uses 512 shift registers to provide a continuously variable electronic delay for complex audio signals. Includes data sheet and applications circuits. 276-1760 10.95

MC14553 3-Digit BCD Counter IC



2.99

For Low-Cost Digital Readout

CMOS chip replaces over 8 separate IC's in a digital display circuit. Input pulse shaping. Master reset pin. 16-pin DIP. 276-2498 2.99

Top-Quality IC and PCB Accessories

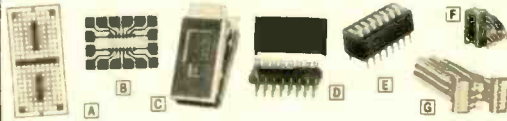

- PC Board. Mounts two 14 or 16-pin ICs or sockets for bread boarding. Copper clad. 2 1/2 x 5 1/16" 276-151 2.99
- PC Board. Mounts single 14 or 16-pin IC or socket. 276-024 Pkg. of 2/99¢
- 15-Pin IC Test Clip. 276-1951 3.99
- 16-Pin DIP Header. With snap-on cover. 276-1980 1.29
- 8-Rocker 16-Pin DIP Switch. 276-1301 1.99
- Vertical 16-pin Socket. For LED displays. 276-1986 1.49
- 16-Pin DIP Jumper Cable. 18" long. 276-1976 3.99

Project Boxes

Aluminum Cover



The popular, low-cost way to house your electronic experiments.

- 3 1/2 x 2 1/4 x 1 1/4" 270-230 1.19
- 4 x 2 1/4 x 2 1/4" 270-231 1.29
- 5 1/4 x 2 1/4 x 1 1/4" 270-233 1.49
- 6 1/4 x 3 1/4 x 2" 270-627 1.79
- 7 1/4 x 4 1/4 x 2 1/4" 270-232 2.49

Miniature Hobby Motors



High-torque permanent magnet type. 1/16" dia. shaft.
 A 12VDC. 350mA. 2x1 1/16" 69¢
 B 6-VDC. 500mA. 1 1/2 x 3/4" 273-209 Pkg. of 2/99¢

SALE Handheld 6-Digit Frequency Counter

Reg. 99.95 **69.95**

- Lead Zero Blanking
- 100 Hz Up to 45 MHz
- kHz and MHz Decimals

Accuracy is 3 ppm at 25°C or less than 30 Hz at 10 MHz. Overload-protected 1-meg input. Sensitivity, 30 mV up to 30 MHz. 3x4 1/2" With mini-rod antenna, leads, case, instructions. Requires 9V battery. 22-351 Sale 69.95
 AC Adapter. U.L. listed. 65-731 4.95



Digital IC Logic Probe 24.95

Multi-Logic Family Compatibility from 5-15VDC

Detects one-shot low repetition rate, narrow pulses scopes miss. Combines level detector, pulse detector and pulse stretcher. Hi-LED indicates logic "1". Lo-LED is logic "0". Pulse LED displays pulse transitions to 300 nanoseconds, blinks at 3 Hz for high-frequency signals (up to 1.5 MHz). With cables. 22-300 24.95



8080A Microprocessor and Support Chips

New — 100% Prime



All With Full Data and Specs

8080A Microprocessor. 2 μs cycle time. 276-2510. 12.95
8208 Bus Driver. 8-bit bidirectional. 276-2508. 5.95
8154 128x8-Bit RAM I/O. 40-pin DIP. 276-2511. 9.95
8212 I/O Port. Data latch and buffer. 276-2512. 4.95
8224 Clock and Generator Driver. 276-2524. 3.95
8228 System Controller and Bus Driver. 276-2528. 6.95
8251 Programmable Communication Interface. 276-2551. 9.95
8255 Programmable Peripheral Interface. 276-2555. 9.95

Custom Printed Circuit Board Kit



Everything you need for making high-quality custom PC boards.
 276-1576 7.95
 Extra Resist Pen. 276-1530 1.29
 Extra Etching Solution. 276-1535 2.19

Computer Data Manuals & Semiconductor Handbook

- Intel 8080/8085 Programming Manual. Handy reference for programming with Intel's assembly language. 62-1377 3.95
- Intel Memory Design Handbook. Explains use of Intel's memory components and support circuits in systems. 62-1378 3.95
- Intel Data Catalog. 928 pages of specifications on most of Intel's standard microcomputer-related products. 62-1379 4.95
- Semiconductor Reference and Application Handbook. Complete specs and applications for popular IC transistors, diodes. 276-4002 1.95

RAM Memory ICs

Under 450 nS Access Time

2102 1024 x 1 Array. Low-cost static memory chip. 16-pin DIP. Buy 8 and save!
 276-2501 2.49 Ea. or 8/14.95
 2114L 1024 x 4 Array. NMOS static RAM. 18-pin DIP.
 276-2504. 12.95

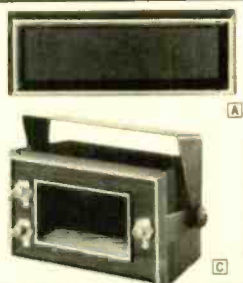

Digital Project Accessories

- Bezel with Lens. High-contrast filter for LED displays. 3/4" x 1" lens opening. 270-301 3.95
- Deluxe Molded Display Case. Red lens. Mount up to four 0.6" or eight 0.3" LED diodes. With brackets. 1 1/2" x 3 1/4" x 7/16". 270-285 3.95
- MA 1003 Clock Case. For car clock modules. Accepts 3 pushbutton switches (not inc.). With brackets, blue lens. 3/4" x 2 1/4" x 2". 270-303 5.95

Molded Connectors



Rated 8A @ 250V. Standard .093" pin diameter.

Fig	Pins	Type	Cat. No.	Each	Fig	Pins	Type	Cat. No.	Each
A	4	Male	274-224	99¢	B	4	Female	274-234	99¢
A	6	Male	274-226	1.19	B	6	Female	274-236	1.19
A	9	Male	274-229	1.39	B	9	Female	274-239	1.39
A	12	Male	274-232	1.49	B	12	Female	274-242	1.49

2-Pin Male & Female. (Not shown) 274-222 Pair 89¢

WHY WAIT FOR MAIL ORDER DELIVERY?
 IN STOCK NOW AT OUR STORE NEAR YOU!

Radio Shack®

A DIVISION OF TANDY CORPORATION • FORT WORTH, TEXAS 76102
 OVER 7000 LOCATIONS IN NINE COUNTRIES

Prices may vary at individual stores and dealers

CIRCLE 25 ON FREE INFORMATION CARD

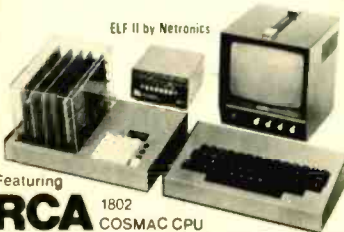

Write and run programs—the very first night—even if you've never used a computer before!

You're up and running with video graphics for just \$99.95 — then use low cost add-ons to create your own personal system that rivals home computers sold for 5-times ELF II's low price!

Featuring

RCA 1802 COSMAC CPU

Own a powerful home computer system, starting for just \$99.95—a price that gets you up and running the very first night—with your own TV for a video display. \$99.95 ELF II includes RCA 1802 8-bit microprocessor addressable to 64k bytes with DMA, Interrupt, 16 registers, ALU, 256 byte RAM, full hex keyboard, two digit hex output display, stable crystal clock for timing purposes. RCA 1861 video IC to display your programs on any video monitor or TV screen and 5-slot plug-in expansion bus (less connectors) to expand ELF II into a giant!

ELF II Explodes Into A Giant!

Master ELF II's \$99.95 capabilities, then expand with GIANT BOARD, KLUGE BOARD, 4k RAM BOARDS, TINY BASIC, ASCII KEYBOARD, LIGHT PEN, ELF-BUG MONITOR, COLOR GRAPHICS & MUSIC SYSTEM, TEXT EDITOR, ASSEMBLER, DISASSEMBLER, VIDEO DISPLAY BOARD and—

More Breakthroughs Coming Soon!

Soon to be introduced, ELF II special application kits that give you the hardware and software you need to use ELF II for specialized purposes such as a telephone dialer, industrial controller, home photography, security system, police alert, motor controller, station output monitor on a conveyor belt assembly line... and some new, super-fantastic games!

Also coming soon: PROM Programmer, A-D, D-A Converter, Controller Board, and more! Unlike some heavily advertised hobby computers, ELF II doesn't limit you to pre-recorded programs. With ELF II you learn computing from the ground up... from machine language to assembly language to BASIC in quick, clear and easy steps. ELF II is a powerful computing tool, but one that you can master with the same ease you once mastered a slide rule or pocket calculator.

Master This Computer In A Flash!

Regardless of how minimal your computer background is now, you can learn to program an ELF II in almost no time at all. Our *Short Course On Microprocessor & Computer Programming*—written in non-technical language—guides you through each of the RCA COSMAC 1802's capabilities, so you'll understand everything ELF II can do... and how to get ELF II to do it! Don't worry if you've been stumped by computer books before. The *Short Course* represents a major advance in literary clarity in the computer field. You don't have to be a computer engineer in order to understand it. Keyed to ELF II, it's loaded with "hands on" illustrations. When you're finished with the *Short Course*, neither ELF II nor the RCA 1802 will hold any mysteries for you.

In fact, not only will you now be able to use a personal computer creatively, you'll also be able to read magazines such as *BYTE*, *INTERFACE*, *AGE*, *POPULAR ELECTRONICS* and *PERSONAL COMPUTING* and fully understand the articles. And, you'll understand how to expand ELF II to give you the exact capabilities you need!

If you work with large computers, ELF II and the *Short Course* will help you understand what they're doing.

Get Started For Just \$99.95, Complete!

\$99.95 ELF II includes all the hardware and software you need to start writing and running programs at home, displaying video graphics on your TV screen and designing circuits using a microprocessor—the very first night—even if you've never used a computer before.

ELF II connects directly to the video input of your TV set, without any additional hardware. Or, with an \$8.95 RF modulator (see coupon below), you can connect ELF II to your TV's antenna terminals instead.

ELF II has been designed to play all the video games you want, including a fascinating new target/missile gun game that was developed specifically for ELF II. But games are only the icing on the cake. The real value of ELF II is that it gives you a chance to write machine language programs—and machine language is the fundamental language of all computers. Of course, machine language is only a starting point. You can also program ELF II with assembly language and tiny BASIC. But ELF II's machine language capability gives you a chance to develop a working knowledge of computers that you can't get from running only

ELF II Gives You The Power To Make Things Happen!

Expanded, ELF II can give you more power to make things happen in the real world than heavily advertised home computers that sell for a lot more money. Thanks to an ongoing commitment to develop the RCA 1802 for home computer use, the ELF II products—being introduced by *Netronics*—keep you right on the outer fringe of today's small computer technology. It's a perfect computer for engineering, business, industrial, scientific and personal applications.

Plug in the **GIANT BOARD** to record and play back programs, edit and debug programs, communicate with remote devices and make things happen in the outside world. Add **Kluge** (prototyping) Board and you can use ELF II to solve special problems such as operating a complex alarm system or controlling a printing press. Add **4k RAM Boards** to write longer programs, store more information and solve more sophisticated problems.

ELF II add-ons already include the **ELF II Light Pen** and the amazing **ELF-BUG Monitor**—two extremely recent breakthroughs that have not yet been duplicated by any other manufacturer.

The **ELF-BUG Monitor** lets you debug programs with lightning speed because the key to debugging is to know what's inside the registers of the microprocessor. And, with the **ELF-BUG Monitor**, instead of single stepping through your programs, you can now display the entire contents of the registers on your TV screen. You find out immediately what's going on and can make any necessary changes.

The incredible **ELF II Light Pen** lets you write or draw anything you want on a TV screen with just a wave of the "magic wand." *Netronics* has also introduced the **ELF II Color Graphics & Music System**—more breakthroughs that ELF II owners were the first to enjoy!

ELF II Tiny BASIC

Ultimately, ELF II understands only machine language—the fundamental coding required by all computers. But, to simplify your relationship with ELF II, we've introduced an **ELF II Tiny BASIC** that makes communicating with ELF II a breeze.

Tiny BASIC saves you the time of having to code your individual instructions in machine language for ELF II. Instead, you simply type instructions on a keyboard—PRINT, RUN, LOAD, ETC. Your **Tiny BASIC** program automatically translates them into machine language for ELF II. Then it translates ELF II's output back into simple words and symbols for you.

Now Available! Text Editor, Assembler, Disassembler And A New Video Display Board!

The **Text Editor** gives you word processing ability and the ability to edit programs or text while it is displayed on your video monitor. Lines and characters may be quickly inserted, deleted or changed. Add a printer and ELF II can type letters for you—error-free—plus print names and addresses from your mailing list!

ELF II's **Assembler** translates assembly language programs into hexadecimal machine code for ELF II use. The **Assembler** features mnemonic abbreviations rather than numerics so that the instructions on your programs are easier to read—this is a big help in catching errors.

ELF II's **Disassembler** takes machine code programs and produces assembly language source listings. This helps you understand the programs you are working with... and improve them when required.

The new **ELF II Video Display Board** lets you generate a sharp, professional 32 or 64 character by 16 line upper and lower case display on your TV screen or video monitor—dramatically improving your unexpanded \$99.95 ELF II. When you get into longer programs, the **Video Display Board** is a real blessing!

Ask Not What Your Computer Can Do, But WHAT CAN IT DO FOR YOU?

Don't be trapped into buying an expensive dinosaur, simply because you can afford it. ELF II is more advanced and more fun to use than big name computers that cost a lot more money. With ELF II you learn to write and run your own programs. You're not just a keypunch operator. No matter what your interests are, ELF II is the fastest way to get into computers. Order from the coupon below!

COMMUNICATIONS CORNER

continued from page 74

is 10 kHz (or 10,000 Hz) to 30 MHz, with provision for a coaxial cable connecting to a dipole or a beam (with an SO-239 connector), longwire or a supplied telescopic whip antenna.

Station tuning is accomplished through two concentric knobs. One knob steps the tuning through 1-MHz increments from 0—30 MHz. The other knob provides continuous tuning, though the readout is calibrated in 1-kHz increments. A fine tuning control provides a very small tuning shift for use during SSB reception (this control is a clarifier). The RF preselector control has six bands, its own tuning adjustment and its own scrolling dial so the user can peak the preselector tuning to a desired segment of any frequency band. Both the preselector control and the MHz tuning control handle final signal peaking (common in Barlow-Wadley circuits).

The end result is precision tuning at a hobbyist's price, plus the frequency coverage below the broadcast band, which is uncommon in SWL receivers. Other features include 120 VAC/12 VDC battery operations; AM, LSB, USB and CW reception; a three-step audio selectivity; 20-dB and 40-dB antenna input attenuators; a standby control; an S-meter, and more.

This discussion of the *model DX-300* receiver wraps up the first column. In the months ahead we hope to keep you up to date on the very latest developments in consumer communications. Sometimes we'll just give you the highlights of several items; other times we'll provide more in-depth coverage.

Unless we hear from you, however, we'll only be guessing at what subjects and equipment meet your particular needs. So take a few moments out to drop us a short note (a postcard is best), and let us know exactly what interests you most in the field of consumer communications.

R-E

Netronics R&D Ltd., Dept RE5
333 Litchfield Road, New Milford, CT 06776

Yes! I want my own computer! Please rush me—

RCA COSMAC ELF II kit at \$99.95 plus \$3 postage and handling requires 6.3 to 8 volt AC power supply.

Power Supply required! \$4.95 postpaid

RCA 1802 User's Manual \$5 postpaid

Tom Pittman's *Short Course On Microprocessor & Computer Programming* teaches you just about everything there is to know about ELF II or any RCA 1802 computer. Written in non-technical language, it's a learning breakthrough for engineers and laymen alike. \$5 postpaid

Deluxe Metal Cabinet with plexiglas dust cover for ELF II \$29.95 plus \$2.50 p&h

I am also enclosing payment (including postage & handling) for the items checked below*

I want my ELF II wired and tested with power supply, RCA 1802 User's Manual and Short Course—all for just \$149.95 plus \$3 p&h

PHONE ORDERS ACCEPTED!
Call (203) 354-9375

Total Enclosed \$ _____ (Conn. res. add tax)

CHARGE IT! Exp. Date

Visa Master Charge

(Bank # _____)

Account # _____

ALSO AVAILABLE FOR ELF II

GIANT BOARD™ kit with cassette I/O DS 232 I/O 110 bit I/O decoders for 14 separate I/O instructions and a system monitor/reader. \$39.95 plus \$2 p&h

Kluge (Prototyping) Board accepts up to 36 IC's \$17.00 plus \$3 p&h

4k Static RAM kit. Addressable to any 4k page to 4k. \$89.95 plus \$3 p&h

Gold plated 86-pin connectors (one required for each plug-in board). \$5.70 ea. postpaid

Expansion Power Supply (required when adding 4k RAM). \$34.95 plus \$2 p&h

Professional ASCII Keyboard kit with 128 ASCII upper/lower case set, 96 printable characters, onboard regulator, parity logic, selection and choice of 4 hand shaking signals to mate with almost any computer. \$64.95 plus \$2 p&h

Deluxe metal cabinet for ASCII Keyboard. \$19.95 plus \$2.50 p&h

Video Display Board kit lets you generate a sharp, professional 32 or 64 character by 16 line upper and lower case display on your TV screen or video monitor—dramatically improving your unexpanded \$99.95 ELF II (if kit inside ASCII Keyboard cabinet). \$89.95 plus \$2 p&h

ELF II Tiny BASIC on cassette tape. Commands include SAVE, LOAD, X, = (1

26 variables A-Z, LET, IF/THEN, INPUT, PRINT, GO TO, GO SUB, RETURN, END, REM, CLEAR, LIST, RUN, PLOT, PEEK, POKE, etc. Comes fully documented and includes alphanumeric operators required to display alphanumeric characters directly on your TV screen without additional hardware. Also plays 14k track 100 plus a drawing game that uses ELF II's hex keyboard as a joystick. 4k memory required. \$14.95 postpaid

Tom Pittman's *Short Course on Tiny BASIC* for ELF II \$5 postpaid

ELF-BUG™ Deluxe System Monitor on cassette tape. Allows displaying the contents of all registers on your TV at any point in your program. Also displays 24 bytes of memory with full addresses, blinking cursor and auto scrolling. A must for the serious programmer! \$14.95 postpaid

Text Editor on cassette tape gives you the ability to insert, delete or edit lines and words from your programs while they are displayed on your video monitor. (Add printer and you can use ELF II to type error-free letters plus insert names and addresses from your mailing list.) \$19.95 postpaid

Assembler on cassette tape translates assembly language programs into hexadecimal machine code for ELF II use. Mnemonic abbreviations for instructions (rather than numerics) make programs easier to read and help prevent errors. \$19.95 postpaid

Disassembler on cassette tape takes machine code

programs and produces assembly language source listings to help you understand and improve your programs. \$19.95 on cassette tape

SAVE \$9.95—Text Editor, Assembler & Disassembler purchased together, only \$49.95! (Require Video Display Board plus 3k memory.)

ELF II Light Pen, assembled & tested. \$7.95 plus \$1.50 p&h

ELF II Color Graphics & Music System Board kit. \$49.95 plus \$2 p&h

ELF II connects directly to the video input of your TV set without additional hardware. To connect ELF II to your antenna terminals instead, order **RF Modulator**. \$8.95 postpaid.

Coming Soon: A-D, D-A Converter, Controller Board and more!

Print Name _____

Address _____

City _____

State _____ Zip _____

DEALER INQUIRIES INVITED



"No matter what the project he's working on is supposed to be—it ends up being a light dimmer."

RADIO-ELECTRONICS

CIRCLE 51 ON FREE INFORMATION CARD

Even competitors agree.

When competitive companies agree on a basic concept, it must be sound. That's why the standards for measuring high fidelity components developed by the Institute of High Fidelity are so widely used by manufacturers. These helpful guidelines enable manufacturers to present their product specifications in a uniform way. As a result, you can rapidly compare hi-fi components because everyone's "audio watts," "microvolts," and "dBs" mean the same thing. They help you and your audio dealer talk on the same wavelength when you're discussing the difference between hi-fi and not so hi-fi products.

IHF measurement standards are now in effect for tuners, amplifiers, and headsets. Additional standards are now being developed for speakers, tape recorders, turntables and cartridges. Look for them in manufacturers' literature and in retail advertising. Then you can buy real high fidelity with complete confidence.

Institute of High Fidelity, Inc.,
489 Fifth Avenue,
New York, N.Y. 10017



SCOTT
Solomon Boucai



KENWOOD
Bill Kasuga



MARANTZ
Fred Tushinsky

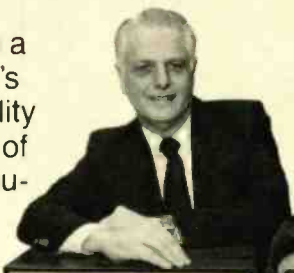

THRESHOLD
Nelson Pass



US JVC
George Meyer



YAMAHA
Stewart Greenberg



PHILIPS
Gerald Orbach



SAE
Malcolm Schmeer



TECHNICS
Jeff Berkowitz



ONKYO
Mark Friedman



HARMAN/KARDON
Richard Aquilina



SANSUI
Ken Hoshino



LUX
Jerry Kaplin



PHASE LINEAR
Bob Morrill



NIKKO AUDIO
John Schroeder



HITACHI
Jerry Henricks



PIONEER
Bernie Mitchell



SONY
Frank Leonardi

Shown above are just a few of the many manufacturers using IHF measurement standards

The reasons for giving up analog.



The best reason is accuracy of 0.25% dc. The 8020A digital multimeter has it, and that's *ten times* better than most analog meters!

And we guarantee that accuracy for a full year, plus we've calibrated your 8020A with equipment that's NBS traceable. A tradition with Fluke.

But you're also buying performance. Like high/low power ohms and *conductance*—the missing function on other multimeters. Ten megohm input resistance on both ac and dc. Plus more, for only \$169.

The tougher your job gets, the more you need resolution, and the 8020A offers a full 2000 counts. The large 3½-digit liquid crystal display is readable

anywhere. Inexpensive 9V battery power means continuous operation for up to 200 hours.

The new 8020A is especially suited for TV service. Measure transistor voltages with 10 millivolt resolution, all the way up to 20V. With the 200Ω range, you also can measure circuit breaker resistances within 0.1Ω. Try that with analog.

Call (800) 426-0361*, toll free, and we'll tell you the location of the closest Fluke office or distributor. Get your hands on the best *digital* multimeter value around.

Price U.S. only.

*Alaska, Hawaii and Washington residents — please call (206) 774-2481.

Command Performance: Demand the Fluke 8020A.

2520-8020



CIRCLE 61 ON FREE INFORMATION CARD FOR LITERATURE

More information on new lit is available from the manufacturers of items identified by a Free Information number. Use the Free Information Card inside the back cover of this issue.

VIDEOTAPE MAGAZINE, *The Videophile*, is a bi-monthly magazine containing information and articles on what's new in the world of VCR's and videotape. In addition to the feature articles, the departments include videotape and book reviews, VCR news and views, a humor section, letters to the editor, and many more. Subscription rates: 6 issues/year, \$10 (Third Class); \$16 (First Class).—*The Videophile*, 2003 Apalachee Parkway, Tallahassee, FL 32301.

CIRCLE 149 ON FREE INFORMATION CARD

WIRE AND CABLE CATALOG provides 96 pages of information on complete wire and cable line, including audio, CATV, intercom, mike, power and TV cables. The following new types of cable are described: computer, control, *Teflon* covered coax, booster and ribbon cables. The catalog also includes conduit-capacity charts, a metric conversion chart and technical data on solid and stranded copper wire.—*Columbia Electronic Cables*, 11 Cove St., New Bedford, MA 02744.

CIRCLE 150 ON FREE INFORMATION CARD

ELECTRONICS CATALOG, 99 pages describing hundreds of discounted items—from adapters to wire-wrap accessories. Includes such equipment as analyzers and testers; meters; color-bar generators; breadboarding materials; transistors; electronic tools; hi-fi equipment; CB's and accessories; service manuals; and troubleshooting guides. A handy order form and postal rate chart are contained in the back. Catalog price: \$1.—*Edlie Electronics, Inc.*, 2700 Hempstead Turnpike, Levittown, NY 11756.

TEST INSTRUMENTS/BREADBOARDS, *Professional Products Catalog*. Catalog contains 32 pages of solderless breadboard equipment and test instruments, ranging from simple sockets and IC clips to lab-quality pulse and function generators, and CSC logical analysis test kits plus accessories. All products are illustrated and come with complete specifications.—*Continental Specialties Corp.*, 70 Fulton Terrace, New Haven, CT 06509.

CIRCLE 151 ON FREE INFORMATION CARD

CATV COAX CABLE GUIDE, *EL-10-78*, lists 20 pages of 59/U-type and 6/U-type drop cable plus converter and accessory cable. Several shielding methods are described, including using *Duobond* and *Duobond II* bonded foil, *Duofoil* foil-film laminate and copper and aluminum braid. Physical and electrical specs are provided along with attenuation ratings. The catalog also contains a description of the *SEED* (Shielding Effectiveness Evaluation Device) for analyzing shield efficiency. Other sections include procedures in braid-coverage calculation, plus a comparison of the performance of bonded versus laminated shielding.—*Belden Corp.*, 2000 S. Batavia Ave., Geneva, IL 60134.

CIRCLE 152 ON FREE INFORMATION CARD

CB RECEIVERS

continued from page 67

read 1000 Hz. Set the receiver for USB operation, and the signal generator for 027.2160 MHz. Again, the frequency counter should indicate 1000 Hz. Any imbalance signifies trouble, probably in the SSB demodulator.

Some CB signal generators make this procedure easy. The USB/LSB switches accomplish an exact 1-kHz frequency shift on whatever channel the generator has been set for.

Other models have a frequency-shift control for sideband tests, but it may not be precisely calibrated for 1-kHz offset. In these sets, upper and lower directions are usually switched, so that one setting of the variable knob still gives equal offsets. You adjust one sideband, either upper or lower, for a 1000-Hz count at the speaker, then switch to the other to verify demodulator balance.

As you may have guessed by now, you can use almost any communications service generator for CB alignment and diagnosis. Special CB test generators such as those described in this article simplify many procedures. In addition, certain generators contain features that widen their versatility. Consider all the features, plus all your needs, before you buy one.

R-E

For
faster
service

USE
ZIP
CODE

on
all
mail

INTERNATIONAL FM-2400CH

FREQUENCY METER FOR TESTING MOBILE TRANSMITTERS AND RECEIVERS

• Portable • Solid State • Rechargeable Batteries

The **FM-2400CH** provides an accurate frequency standard for testing and adjustment of mobile transmitters and receivers at predetermined frequencies.

The **FM-2400CH** with its extended range covers 25 to 1000 MHz.

The frequencies can be those of the radio frequency channels of operation and/or the intermediate frequencies of the receiver between 5 MHz and 40 MHz.

Frequency stability: $\pm 0.0005\%$ from $+50^\circ$ to $+104^\circ\text{F}$.

Frequency stability with built-in thermometer and temperature corrected charts: $\pm 0.00025\%$ from $+25^\circ$ to $+125^\circ$ (.000125% special 450 MHz crystals available).

- Tests Predetermined Frequencies 25 to 1000 MHz
- Extended Range Covers 950 MHz Band
- Pin Diode Attenuator for Full Range Coverage as Signal Generator
- Measures FM Deviation

FM-2400CH (meter only) Cat. No. 035320	\$627.72
RF crystals (with temperature correction)	26.26 ea.
RF crystals (less temperature correction)	19.93 ea.
IF crystals	catalog price

SOLID-STATE REPLACEMENTS FOR TV HV RECTIFIER TUBES

AVAILABLE FROM STOCK FROM YOUR DISTRIBUTOR



Replace vacuum and gas rectifier tubes with thoroughly proved (in use for over 8 years) solid-state, silicon rectifier Solid-Tubes.® They meet or exceed standard tube ratings. Only 6 replace 37 vacuum tubes. Off shelf distributor delivery.

You'll make more money because there's a bigger profit and your customer will get: no more filament burn out (They're perfect replacements when the HV filament transformer burns out.) Constant output. Long life; reliable and dependable. No warm up. No heat. Replacements available for all tubes.

SOLID-STATE TUBE CROSS REFERENCE LIST

	SYLVANIA	GENERAL ELECTRIC	ZENITH	RCA
EDI				
R-3A3	ECG-508	GESS-3A3	S-3A3	SK3756
R-3AT2	ECG-509	GESS-3AT2	S3AT2	SK3757
R-3DS3	ECG-514	—	—	SK3761
R-3DB3	ECG-510	GESS-3DB3	S-3DB3	SK3758
R-2AV2	ECG-511	GESS-2AV2	—	SK3759
R-DW4	ECG-512	GESS-6DW4	—	SK3760
R-3DR3	ECG-514	GESS-3DS3	—	SK3761

Send For Complete Information Kit

edi® **electronic devices**
21 Gray Oaks Ave., Yonkers, N.Y. 10710
(914) 965-4400, TWX 710 560-0021

CIRCLE 8 ON FREE INFORMATION CARD



INTERNATIONAL CRYSTAL MFG. CO., INC.
10 North Lee / Oklahoma City, Okla. 73102

CIRCLE 44 ON FREE INFORMATION CARD

HOBBY CORNER

Here's a BFO circuit for shortwave receivers that helps clarify reception.

EARL "DOC" SAVAGE, K4SDS, HOBBY EDITOR

THE MAILBAG HAS BEEN VERY INTERESTING lately. There are a number of reader questions that I will share with you just as soon as we finish discussing our new subject first:

Beat-frequency oscillator (BFO)

Have you ever wondered about that "duck talk" you run into on your SWL receiver (that's single-sideband of course)? And what about the puffing sounds you hear when receiving continuous-wave (CW) code?

If you want to make sense out of those sounds, you will have to add a beat-frequency oscillator (BFO) to your receiver. Both SSB and CW require a steady signal in the receiver in order to be intelligible. The BFO described this month can be used with the shortwave receiver on your desk or your multiband portable receiver.

Several months ago we discussed crystal-controlled oscillators; and we stated that these could be used as a BFO with the proper crystal installed. This month's BFO circuit has several advantages over the crystal circuit. First, its components are less costly. Second, the device is smaller. Third, it can be tuned for maximum effectiveness.

This BFO is designed for use with any receiver having an intermediate frequency (IF) range of from about 400 kHz to 500 kHz. As the most common IF is 455 kHz, this BFO will work with most receivers. If your receiver has a different IF simply use an appropriate IF transformer in the BFO circuit.

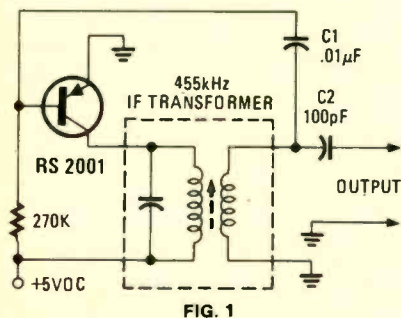

FIG. 1

Figure 1 shows the BFO circuit. You'll note that it requires few parts. Most

NPN switching transistors will oscillate well, but if you use something other than the Radio Shack RS2001 shown in the diagram, you may have to vary the bias resistor. The applied voltage can vary over a wide range but it should be stable.

In order to save space, use a subminiature IF transformer (buy it or "steal" it from an old radio). The impedance is not critical, since we tried several in this circuit and all worked equally well. Just be sure that the one you use has a built-in capacitor on the primary side because the transistor has to have a tuned circuit or nothing will happen. Subminiature oscillator coils come in the same kind of containers but they have no internal capacitor.

If your BFO does not oscillate, exchange *either* the input *or* output leads of the transformer; do not change both sides. Capacitor C1 provides feedback to sustain the oscillation. You may want to experiment with its value.

Capacitor C2 serves two functions: It isolates the BFO operating voltage (+5 volts) from the receiver yet allows the 455-kHz signal to pass. Changes in its value will vary the strength of the signal applied to the receiver.

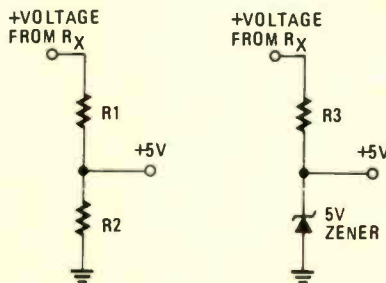

FIG. 2

The BFO is built on a small (2 cm × 4 cm) piece of perforated board. The operating voltage can be supplied by a couple of flashlight batteries. However, when the BFO is installed in a receiver, the best practice is to use one of the circuits shown in Fig. 2 to obtain power from the receiver and save battery space.

The values for R1, R2 and R3 will depend upon the value of the voltage

"stolen" from the receiver. You can compute the necessary values using Ohm's law ($E = I \times R$). However, trial-and-error experimentation will also do the job. In any case, use larger resistor values in order to draw just a few milliamps from the receiver. You should install a switch in the power line so that you can disable the BFO when you want to listen to AM stations.

Connecting the BFO to the receiver will undoubtedly require some manipulation for it to reach maximum effectiveness. Of course, we can't give exact instructions for all radios, but here are some general guidelines.

Getting the BFO to "inject" the right amount of signal into the receiver's IF is quite important. Too much BFO signal swamps or even blocks out incoming signals. Too little BFO signal won't do the job either. The amount of injection or signal BFO will be determined by the size of the coupling capacitor (C2 in Fig. 1), and by where in the IF chain you make the connection. Vary both of these if necessary to get the right amount of signal.

With the BFO connected but turned *off*, tune in a moderately strong broadcast station. Use the S-meter, tuning indicator and/or the quality and volume of sound to be sure that the receiver is tuned to the exact station frequency. Now, turn the BFO *on*, and you should hear a beat note or whistle. If not, turn the slug in the BFO transformer until you do hear one.

Next, adjust the slug to give a beat-note frequency of about 800 Hz. Then, adjust the coupling capacitor and/or the connection point until the note or whistle sounds about as loud as the broadcast-station signal.

That is all you have to do if you are interested only in CW (code) reception. However, if you also want to receive SSB signals, you must make additional adjustments. Single-sideband transmissions come in two varieties—upper and lower. With the present BFO adjustment, upper SSB signals may be strong and readable but lower SSB signals will be weaker and not readable (or vice versa).

In order to improve reception with stations using the weaker sideband transmission, you must turn the BFO slug to give a lower note, passing through zero and back up the other side. This is inconvenient when you are receiving different

FREE! EDMUND SCIENTIFIC CATALOG

Explore Astronomy, Biofeedback, Computers, Health, Lasers, Magnets, Microscopes, Optics, Photography, Weather... Over 4,000 Fascinating Items, More Than 160 Colorful Pages... The Exciting, FREE Edmund Catalog!

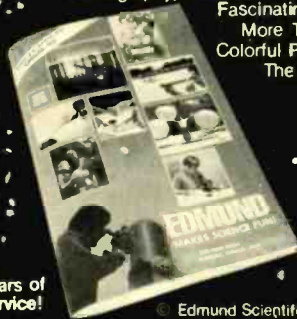

38 Years of Service!

No. 108
© Edmund Scientific Co. 1979

Yes! Rush me your FREE Catalog so that I can explore Edmund's World of Science.

Name _____
Address _____
City _____
State _____ Zip _____

Clip and Mail Coupon Today to:
Edmund Scientific Co., EH10
Edscorp Bldg., Barrington, N.J. 08007

Try this exciting new hobby!

Build your own electronic concert organ. It's easy. No technical knowledge required. Just follow the clearly pictured instructions of the famous Wersi do-it-yourself system. Choose from seven different models. Send \$2.00 (refundable) with coupon for colorful 104 page catalog.

WERSI



Wersi Electronics, Inc.
Dept. 42,
1720 Hempstead Road
Lancaster, PA 17601

Enclosed is \$2.00 for my copy of your 104 page catalog.

Name _____
Address _____
City _____ State _____ Zip _____

CIRCLE 28 ON FREE INFORMATION CARD

stations, so you must do one of two things:

The first option is to build a second BFO and tune it to the other side of zero beat. Then, you could simply switch from one BFO to the other. The second option is a compromise.

Oversimplification

In the November 1978 issue, we discussed parts substitution. At that time, I showed how to change the value of a potentiometer—specifically, how to make a 175K pot out of a 500K pot and a 270K resistor (see Fig. 3).



FIG. 3

Bill Clements, K4GMR, has pointed out to me that this is not always possible. It depends upon how the device is used. If it is used as a voltage divider (using all three terminals), the combination works like a single pot. Because most applications involve this type of use, you may never have noticed the exception.

However, when the combination is used as a two-terminal device, it does *not* function as a simple variable resistor. Place it into an audio tone-control circuit or into the R-C control circuit of a 555 timer, for example, and strange things may happen.

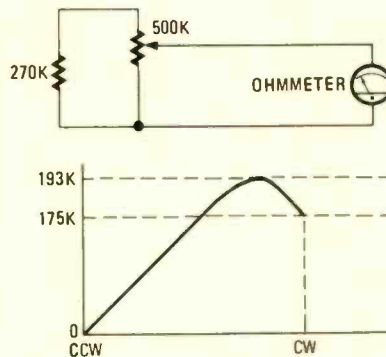

FIG. 4

In two-terminal use, with some values the resistance does not increase from zero to maximum as the arm is turned. The value may go from zero to a maximum, and then *down* to the value of the parallel combination!

Bill enclosed a complete mathematical analysis to show that the example given above varies from zero up to 193K and then back down to 175K. Space won't permit including his analysis, but to check out his conclusion, you can give it the old breadboard test. The results will be something like those shown in Fig. 4.

I'll have to admit that a pot acting like
continued on page 84

AT LAST! AMELECT CHIMES

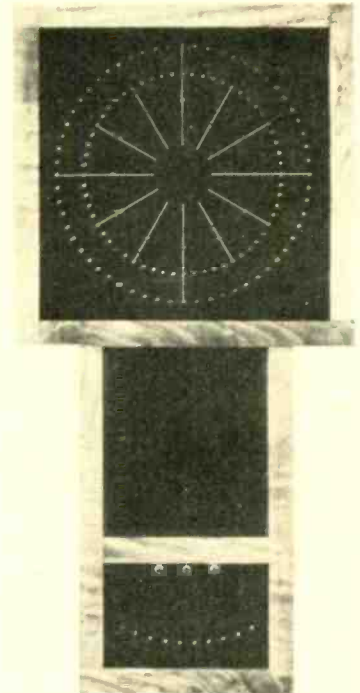

The AMELECT CL7402 Grandpa wall clock as advertised in April, August and November 1978 issues of Radio Electronics now has complete sound.

FEATURING:

1. A realistic tic-toc sound: hear the seconds go by.
2. Beautiful, modified Westminster chimes have synthesized sounds composed of six frequencies. Four notes are provided on the quarter hour, eight notes on the half hour, twelve notes on the three quarter hour, and sixteen notes on the hour.
3. Following on the hour chimes, the hour displayed on the clock is counted out using the lowest chime note.
4. Chime volume, tic-toc volume, pitch and decay are adjustable.

Available assembled or in kit form. Can easily be added to any Amelect Clock.

CH7702	Chimes assembled	\$45.00
CH7702 K	Chimes kit	\$39.00

Indiana residents include 4% sales tax.
Shipping and Handling \$3.50
To order write or call 1-219-297-3320

AMELECT

INCORPORATED
P.O. Box 367—106 S. Newton St.
GOODLAND, INDIANA 47948

Allow 3-4 weeks for Del.

CIRCLE 45 ON FREE INFORMATION CARD



PHILIPS

HICKOK



DORIC



Non-Linear Systems



DIGITAL MULTIMETERS

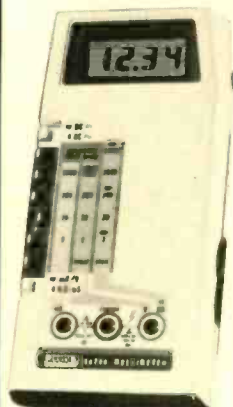

8020A

- 26 Ranges—5 Functions plus New Conductance Function for up to 10,000 M Ω Leakage Measurements
- Extensive Overload and Transient Protection
- Rugged Construction—1 Year Warranty
- HI/LO Power Ohms for In-circuit Resistance and Diode Testing
- 10 M Ω AC/DC Input Impedance Doesn't Load Circuit
- 200 Hour, 9V-Battery Life—Low Battery Indicator
- Large LCD Readout—2000 Counts
- 1 Year Calibration Cycle—Only 3 Adjustments
- One Hand Operation
- Complete with Battery and Test Leads

The new Fluke 8020A continues the standard of excellence set by the highly successful 8000A multimeter family. Many features set the 8020A apart as a truly exceptional instrument. Twenty-four ranges and 5 functions include measuring capability up to 1000V ac, 750V ac, 2A ac/dc and 20 M Ω HI/LO ohms are included for in-circuit resistance and diode test capability. In addition, a new Conductance function allows resistance and leakage measurements up to 10,000 M Ω , a must for circuit board work and component checking.

The 8020A has been designed with the user in mind and features exclusive one-hand operation. For harsh service environments, the 8020A has a ruggedized case and extensive overload/transient protection backed up by a 1-year warranty. Long term stability (1-year calibration cycle) is excellent with only three cal. adjustments. Up to 200 hours of continuous operation can be expected from a single 9V alkaline battery.

BASIC SPECIFICATIONS

	DC Volts	AC Volts	DC Current	AC Current	Ohms	Conductance
Range	0.2-1000V	0.2-750V	0.002-2A	0.002-2A	200 Ω -20 M Ω	200 nS-2 mS
Resolution	100 μ V	100 μ V	1 μ A	1 μ A	0.1 Ω	0.1 nS
Accuracy*	(0.25 + 1)	(0.75 + 2)	(0.75 + 1)	(1.5 + 2)	(0.2 + 1)	(0.3 + 1)

\$169.



DIGITAL MULTIMETERS

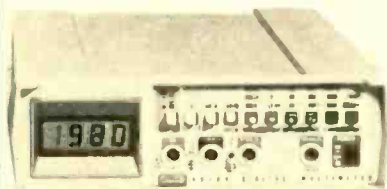

8010A and 8012A

- Large 3 $\frac{1}{2}$ -Digit LCD's - view in any light
- Conductance function - resistance to 10,000 M Ω
- AC measurements to 50 kHz and higher
- True RMS for ac accuracy
- Touch-hold probe for tricky pieces (19008)
- Diode test and low power ohms
- One year accuracy reduces calibration costs
- COMMON floatable to 500V
- Recessed jacks reduce shock hazard
- Current mode fuse protection to 600V
- Voltage mode transient protection to 6 kV
- Autozero and autooffset
- AC or DC current to 10 amps with 8010A
- Resistance resolution to 0.001 Ω with 8012A
- Built-in batteries and charger (Option -01)
- Rugged enough for field or bench

MULTIFUNCTION COUNTERS

1900A, 1910A, 1911A, and 1912A

LCR-740 Transistorized LCR Bridge

LEADER Instruments Corp.

\$269.95

Regular price \$320.



- Highly accurate 3 unit digital readout.
- Measures inductance (L), Capacitance (C), and Resistance (R), within $\pm 0.5\%$ accuracy.
- Operates on one 9V battery

New Portable Digital Capacitance Meter



Reg. price \$130.

\$109.95

MODEL 820

- Measures capacitance from 0.1pF to 1 Farad
- Responds to 0.1pF
- 10 ranges for accuracy and resolution
- 4 digit easy-to-read LED display
- 0.3% accuracy
- Special lead insertion jacks or banana jacks
- Fuse protected
- Uses other rechargeable or disposable batteries
- Overrange indication

BK PRECISION

Solid-State RF Signal Generator



MODEL E2000

- 100kHz to 50MHz coverage in 5 fundamental bands and harmonics to 210MHz
- Completely shielded RF output with modulation percent metering and variable monitored attenuation usable to less than 1 μ V
- Built-in 100kHz and 1MHz crystal calibration system
- Easy-setting 2-color 8" anti-backlash vernier dial

\$249.95

Regular price \$300.

BK PRECISION

3-1/2 Digit DMM with .5% Accuracy

MODEL 2810

- 3 $\frac{1}{2}$ digit easy to read LED display
- 0.5% DC accuracy typical
- 100,000:1 resolution
- 10 ohm range and control to zero lead resistance
- Selectable High/Low-power ohms on four ranges
- Auto zeroing

\$109.95

Regular price \$130.



BK PRECISION

Laboratory Power Supplies

Model 1650

- Functions as three separate power supplies
- 0VDC, 5A load output
- Two separate 0 to 25VDC outputs at 1.5A

Reg. price \$275
\$229.95

Model 1601

- Isolated 0-10VDC, continuously regu- lated, 0.2A 50 hour/ range
- Fully automatic shutdown, adjust- able current limit

Reg. price \$265.
\$224.95

New Sweep/Function Generator



MODEL 3020 BK PRECISION

- Four instruments in one package—sweep generator, function generator, pulse generator, tone-burst generator
- Covers 0.02Hz-2MHz
- 1000:1 tuning range
- Low-distortion high-accuracy outputs
- Three-step attenuator, plus vernier control
- Internal timer and log sweeps
- Tone-burst output is front-panel or externally programmable

Regular price \$325. \$269.95

New Low Distortion Function Generator



MODEL 3010 BK PRECISION

- Generates sine, square and triangle waveforms
- Variable amplitude and fixed TTL square-wave outputs
- 0.1 Hz to 1MHz in six ranges
- Push button range and function selection
- Typical sine wave distortion under 0.5% from 0.1 Hz to 100 kHz
- Variable DC offset for engineering applications
- VCO external input for sweep-frequency tests

Regular price \$175. \$149.95

Simpson

BK PRECISION

LEADER

TRIPLETT

VIZ formerly **RCR**

DATA PRECISION

Dual-Trace 5" 30MHz Triggered Scope...



MODEL
1474

- Rise time 11.7 nS or less
- Built-in signal delay line permits view of leading edge of high frequency pulse 100 times
- Triggers on signals up to 50 MHz
- 5mV/cm vertical sensitivity
- Mode automatically shifts between CHOP and ALTERNATE as you change sweep time
- Checks most digital logic circuitry, including ECL
- High accuracy ten position vertical input attenuator
- Fast response with smooth roll-off past 30 MHz
- PDA CRT with P31 phosphor
- Built-in high and lowpass filters
- Maintains calibration accuracy from over 100-110 VAC and 200-240 VAC
- 20 calibrated sweeps—0.2 μ S/cm—0.5 μ S/cm
- Differential input capability
- Algebraic addition and subtraction
- Built-in RF detector for modulation envelope display
- Illuminated graticule

QUANTITIES LIMITED **\$799.⁹⁵**

Probes not included in price.

BK PRECISION

30MHz Dual Trace with Delay Line

LEADER
Instruments Corp.

LBO-520

\$889.⁹⁵

Regular price \$1050.



- Single Shot Trigger on CH-1 & CH-2 helps capture transient phenomena without guesswork or time wasting double checks
- Built-in 120 nanoSec delay line simplifies viewing of leading edge of pulse or pulse train
- 5mV/cm sensitivity facilitates accurate signal viewing from low level sources.
- 20nS/cm sweep capability, 11.7nSec rise time for observation of the fastest signals
- 5 PDA CRT assures bright, sharp trace at all sweep speeds
- Z Axis modulation
- Numerous applications — VTR microprocessors, computers, production, laboratory and field service

20MHz Dual Trace

LBO-508

\$639.⁹⁵

Regular price \$770.



- Automatic trigger from CH-1 or CH-2, including TV synch
- Add & subtract modes, (with CH-2 invert), for quick analysis of signals, amplitude, etc.
- Automatic select, in dual mode, of alternate & chop
- Front panel, pushbutton, X-Y operation for phase shift, analysis, sweep alignment
- 10mV vertical sensitivity with $\pm 3\%$ accuracy
- 17.5 nanosec Rise Time for easy viewing of high speed pulses
- Horizontal format, 5" CRT, 8x10 Div, with bright, effective display
- Logically grouped, convenient, front panel controls facilitate quick, easy operation

LEADER
Instruments Corp.

NLS

Non-Linear Systems

MS-215

Reg. price \$435.

\$359.⁹⁵

15 megahertz

QUANTITIES LIMITED

BATTERY OPERATED

MS-15

Reg. price \$318.

\$269.⁹⁵

PORTABLE OSCILLOSCOPES

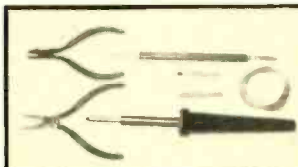

FREE TOOLS

With the purchase of \$750 or more you get these quality tools worth over \$34 :
WELLER 25 watt soldering iron kit, (SP23K)
XCELITE 4" cutters and 4" pliers. (54, 41CG)

OFFER EXTENDED TO MAY 31, 1979

Shipping not included in prices.

5MHz Solid State 3" Oscilloscope



MODEL
1403A

- 5 MHz with high sensitivity
- For production lines, schools, field service work, hobbyists
- CB modulation monitor
- Ultra-compact and lightweight, goes anywhere!
- Use the 1403A to release more expensive scopes from monitoring applications
- Vertical sensitivity of 10mV/division
- High brightness CRT and smoked-glass graticule
- Can be externally synced
- Direct deflection terminals for waveform display up to 450MHz
- Z-axis input for intensity modulation



\$214.⁹⁵

Regular price \$255.

BK PRECISION

New 15MHz portable 3" dual-trace scope



BK PRECISION

MODEL
1432

- 15MHz bandwidth with smooth roll-off; usable response extends beyond 30MHz
- 2mV/div. vertical sensitivity
- Operates on 117VAC, 234 VAC, 12VDC or optional internal battery pack
- Fully regulated high- and low-voltage supplies
- Algebraic addition and subtraction of Channel 1 and 2 input signals
- Nineteen calibrated sweep ranges cover 0.5 microsecond to 0.5 second
- TTL Compatible Z-axis input
- Compact size; measures only 5.5 x 8.25 x 14.5"
- Includes two atm body 10/100 direct probes and accessory tips
- Built-in sync separators

\$699.⁹⁵

Regular price \$840.

THE TEST EQUIPMENT SPECIALISTS

MASTER CHARGE
VISA

**TOLL FREE HOT LINE
800-223-0474**

ADVANCE ELECTRONICS

Announcing a major breakthrough in design time.

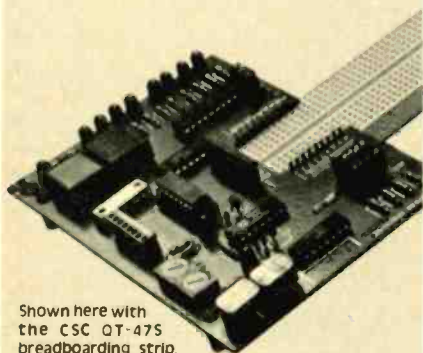

Shown here with the CSC QT-475 breadboarding strip.

The FTK 6100 Universal Designer is an indispensable aid to breadboarding digital IC's. It plugs directly into breadboards such as the Continental Specialties QT-475, and provides the most often used inputs and outputs for circuit design.

- 2 Bounceless Pushbuttons
- 2 Readouts with BCD Inputs
- 4 Switch Outputs
- 8 LED Monitors
- 2 Variable Clock Generators
- Operates on a 6 volt Battery
- 2 Decade Counters
- 5 volt Supply Pins

Price per Kit: \$34.95

Assembled: \$44.95

Send check or money order to:



14825 N.E. 40th St.,
Suite 340
Redmond, WA 98052
(206) 883-9200
TWX: 910-449-2592

Dealer Inquiries Invited.

Washington residents add sales tax.

HOBBY CORNER

continued from page 81

that could produce very confusing results in some circuits. I surely hope no one has pulled out his hair over one since last November! Many thanks to Bill Clements for calling this to our attention.

Reader circuit

Bill Cikas, Rockford, IL, sent in the very interesting circuit shown in Fig. 5. He calls it a "dual LED CMOS flasher," and suggests that it can be used as a crossing light on model railroad layouts. I am sure many other uses will occur to you as you watch the LED's light up alternately.

In this circuit, inverters IC1-a and IC1-b form a multivibrator and IC1-c is a buffer. Inverter IC1-d is connected so that its output is opposite that of IC1-c—when pin 6 is high, then pin 8 is low and vice versa. Because pins 6 and 8 are constantly changing state, first one LED and then the other is *on* since they are connected in reverse. The light seems to jump back and forth between the LED's.

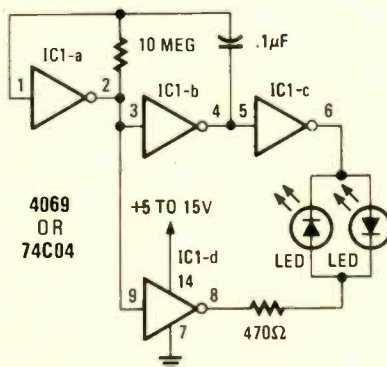

FIG. 5

The 470-ohm resistor protects the LED's by limiting the current through them. Depending upon the actual supply voltage used, the value of the resistor may have to be changed to obtain maximum light output without blowing the LED's.

You can change the switching rate by changing the value of the capacitor. However, don't make the rate too fast, or it will appear that both LED's are *on* all the time.

Thanks, Bill, for sharing your circuit with us.

Readers need help

Once again, readers are having problems. Most of you did very well answering the last questions, so put on the old thinking cap again and see what you can devise. Send along your answers and we'll share the best ones. Here are the problems:

Mr. Taggart of California wants to have wireless control of his TV sound from his chair across the room. He is will-

ing to use a flashlight beam to do so. How would you turn the sound *on* and *off* or *up* and *down*?

Here are some suggestions: The pick-up might be a photoresistor, a phototransistor, a light-activated SCR, etc. The switch could be a relay, a triac, etc. The circuit could operate only when the light is on it, or go *on* and *off* with alternate light flashes. How about controlling the circuit with sound instead of light?

Mr. Taggart doesn't tell us *exactly* what he has in mind. Perhaps he wants quiet when the telephone rings. Or perhaps he objects when commercials seem too loud. If he wants to cut the sound *down* or *off*, there may be a better way to do this.

Can you devise something that modulates the sound *automatically*? How about running audio through an amplifier, then a rectifier and using that voltage to operate a relay when it reaches a preset level?

Here's another challenge for you: Mr. Prado (also of California) wants a circuit that will produce a sound (or whatever) to keep *mosquitos* away. (Now, just a minute—I thought there wasn't enough rain in sunny California to grow *mosquitos*!)

Mr. Cantley in Michigan wants a squelch circuit. He has one of those CB converters on his car radio, and says the CB comes in very well, but when no one is talking, the noise is driving him crazy.

Well, how about it? Can you help these readers? If so, send along the information to **Radio-Electronics** and you may see your circuit in a future issue. **R-E**



Get every excitement-packed issue of Radio-Electronics delivered to your door. And save money, too—up to \$18 off newsstand prices! Use the handy coupon and subscribe today!

Mail to: **Radio-Electronics**
SUBSCRIPTION DEPT., P.O. BOX 2520,
BOULDER, COLO. 80323 (please print)

Name		
Address		
City	State	Zip Code

Indicate the offer you prefer:

1 Year—12 Issues ONLY \$9.98 (You save \$5.00 off newsstand price.)

2 Years—24 Issues ONLY \$19.00 (Save More! \$11.00 off newsstand price.)

3 Years—36 Issues ONLY \$27.00 (Save Even More! Save \$18.00 off newsstand price.)

Payment enclosed Bill me

Check here if this is a new subscription.

Check here if you are extending or renewing your subscription.

Extra Shipping: Canada \$3.00 per year, all other countries \$5.00 per year. **40E9**

computer products

More information on computer products is available from manufacturers of items identified by a Free Information number. Free Information Card is inside the back cover.

GAME SOFTWARE for 8K PET computer is available on cassette tape. The tape features 10 programs, including "Hangman II," "Pro Tic-Tac-Toe," "Psychological Test," "Mystery Quiz," plus



CIRCLE 121 ON FREE INFORMATION CARD

6 others. All programs use PET graphic capabilities. Tape No. 1 with 10 programs costs \$5, post-paid.—VIP Enterprises, Box 17011, Salt Lake City, UT 84117.

MEMORY MODULES come in 32K, 48K, 64K and 128K-byte versions and are compatible with Xitan's ZPU-2 extended addressing capability, allowing up to 1 megabyte of RAM to reside on-line. Modules use 16-pin dynamic memory IC's.

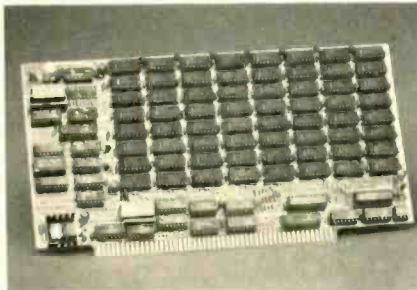

CIRCLE 122 ON FREE INFORMATION CARD

Timing is controlled by a precision digital delay line and the refresh rate is controlled to insure minimum power usage. All boards reside in non-memory mapped environment as a contiguous block, except for 128K version, which requires a memory-mapped environment. Suggested retail price for the K-32 memory module, \$799.—Xitan, Inc., 1057 Main St., Hanson, MA 02341.

KIM ADAPTERS, KIM-1 Interface Sets, provide 20 I/O lines from KIM-1 computer to either standard terminal-strip breadboards or to TERC's Modular Breadboarding System (shown). The adapter connects directly to the KIM-1 applications connector and also provides convenient

power, tape-recorder and TTY connections. Applications using these adapters have been developed including data-logging with display, signal generation, timing and nuclear instrument applications, using just the KIM computer, this adapter and breadboarded I/O circuits. Software, course material and breadboards also available. Adapters are available on a limited basis at cost as an educational service. Suggested retail prices: two-board set (shown), \$60; single boards



CIRCLE 123 ON FREE INFORMATION CARD

with terminal-strip adapter, \$36.—TERC Services, 575 Technology Square, Cambridge, MA 02139.

MICROCOMPUTER, models VDP-40, VDP-42, VDP-44, is a complete system containing 8085 microprocessor, 32K/64K RAM, dual 5 1/4-inch floppy discs (MDOS), 9-inch CRT, keyboard and serial I/O. The VDP-40, VDP-42, VDP-44 have a disc storage capacity of 180K, 400K and 780K bytes, respectively. A storage capacity of 780K



CIRCLE 124 ON FREE INFORMATION CARD

bytes is achieved by combining the IMDOS disc format with 77-track double-density mini-disc drives. The serial I/O can be used to drive line printer, modem or auxiliary terminal. Suggested retail prices: model VDP-40, \$4495; model VDP-42, \$4695; model VDP-44, \$4995.—IMSAI Manufacturing Corp., 14860 Wicks Blvd., San Leandro, CA 94577.

DUAL-DRIVE FLOPPY DISC SYSTEM, model PCS-80/21 and PCS-80/22, features CalComp model 142M disc drives. System configurations are based on either IMSAI's DIO-C or FIF controller. Either controller will support up to 4 drives. The DIO-C controller will provide over 2.4 megabytes on-line storage. The DIO-C controller is compatible with all IMSAI 8080/8085 systems, and is supported by multi-disc operating system Version 2.05. FIF controller provides 256K bytes

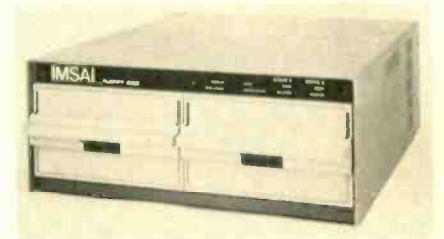

CIRCLE 125 ON FREE INFORMATION CARD

storage capacity-per-drive; is compatible with IMSAI's 1-8080 computer; and uses DMA for data transport.—IMSAI Mfg. Corp., 14860 Wicks Blvd., San Leandro, CA 94577.

HOME COMPUTER Sirius II, contains Mostek Z80 and Fairchild 3870 microprocessors. Comes with 32,768 characters of read/write memory, RS-232 I/O interface, PROM board with 1000-character monitor (supplied), mini-floppy disc drive, 64-key alphanumeric/graphic keyboard



CIRCLE 126 ON FREE INFORMATION CARD

and TV Interface. Also included are a BASIC interpreter, monitor, and software (from home management to games). Additional hardware available includes RS-232 I/O, parallel I/O, and mini-floppy disc drives; plus add-on 16,384 byte RAM cards and A/D-D/A converters. Suggested retail price: \$1850.—Digital Sport Systems, 7th and Elm Sts., West Liberty, IA 52776.

COMPUTER SOFTWARE, Disc File Check Maintenance System, is used on BFD-68 or MF-68 6800 systems. Ten-program disc performs all checking account maintenance operations, including tax records and is linked to a MENU program. The system also contains a master file directory, but allows user to backup his own files. A program disc and operating manual are provided. Suggested retail price: \$49.95.—Computerware Software Services, 830 First St., Encinitas, CA 92024.

CIRCLE 127 ON FREE INFORMATION CARD

a write signal. Since the 8080 processor does not operate or execute program steps while it is in the HOLD mode, it cannot generate a read or a write signal. By using the HLDA signal to enable the read and write signals generated by the external device, the proper signals will be generated by either the 8080 in the normal mode and by the external device in the HOLD mode.

While the DMA interface described thus far does not seem to be very useful, since it transfers only one 8-bit data word to a single location, it *does* illustrate the simplicity with which a DMA interface can be constructed. In most situations, however, a block of data will be transferred between the memory and an external device. Note that the transfer may be in either direction—i.e., from a high-speed data-acquisition device to the computer memory, or from the computer's memory to a high-speed data-storage device, such as a floppy disc.

In one application, a series of SN74193 programmable up-down counters were used to provide the 16-bit address information during the DMA transfer, and a first-in/first-out (FIFO) buffer memory was used to provide a block of data to the microcomputer's memory. Some simple control logic generated a write pulse (MEMW) and then incremented the address (count) present at the SN74193

continued on page 92

The American Economic System

We should all learn more about it.

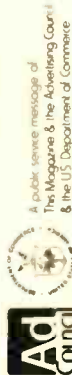

A public service message of
The Magazine & The Advertising Council
& the U.S. Department of Commerce



Clever Kleps

Test probes designed by your needs—Push to seize, push to release (all Kleps spring loaded).

- Kleps 10.** Boathook clamp-grips wires, lugs, terminals. Accepts banana plug or bare wire lead. 4¾" long. \$1.59
- Kleps 20.** Same, but 7" long. \$1.69
- Kleps 30.** Completely flexible. Forked-tongue gripper. Accepts banana plug or bare lead. 6" long. \$1.99
- Kleps 40.** Completely flexible. 3-segment automatic collet firmly grips wire ends, PC-board terminals, connector pins. Accepts banana plug or plain wire. 6¾" long. \$2.89
- Kleps 1.** Economy Kleps for light line work (not lab quality). Meshing claws. 4½" long. \$1.09
- Pruf 10.** Versatile test prod. Solder connection. Molded phenolic. Doubles as scribing tool. "Bunch" pin fits banana jack. Phone tip. 5½" long. \$.99

All in red or black - specify. (Add 50¢ postage and handling). Write for complete catalog of test probes, plugs, sockets, connectors, earphones, headsets, miniature components.

Available through your local distributor, or write to:



RYE INDUSTRIES INC.
132 Spencer Place, Mamaroneck, N.Y. 10543
In Canada: Rye Industries (Canada) Ltd.



Nobody does it better than VIZ

ISOTAP® Isolation Transformers MINIMIZE SHOCK HAZARDS

Here's new safety for service technicians. Protection for test instruments. ISOTAP provides AC output voltages isolated from AC power lines. You need an ISOTAP for servicing any transformerless equipment. Absolutely necessary for today's solid state TVs and stereos. Essential for safe servicing in the industrial plant, laboratory or technician training school.

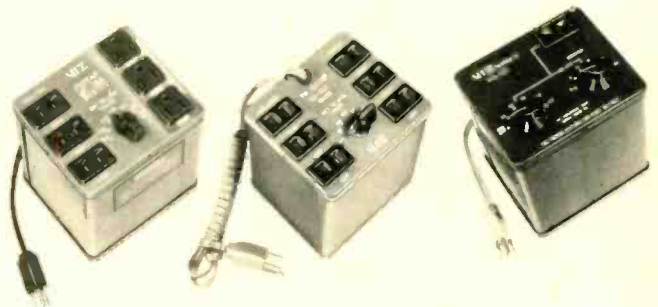

WP-25A

275 VA isolated, 500 VA direct. Outputs at 105, 115 and 130 V. \$49

WP-26A

400 VA isolated, 500 VA direct. Outputs at 105, 115 and 130 V. \$58

WP-27A ISOTAP II

400 VA isolated only. Outputs 25 to 150 Vac in 5V steps. \$68

NEW Porta-Isotap WP-28 \$44.95



Compact, lightweight unit. Ideal for TV servicing. Easily carried for house calls. Has two fused outlets: (1) Isolated, 150 VA continuous for solid state TV; (2) Direct, 500 VA, a convenient power source for service instruments. Comes with accessory cords to take power from TV set back. No need to hunt for wall outlet. Weight 8 lb. Dimensions 3¾ x 3¾ x 5¾ in. See your local VIZ distributor.

VIZ Test Equipment Group

335 E. Price St., Philadelphia, PA 19144
The VoltOhmyst company



An introductory Electronics



LOGIC DESIGNER'S MANUAL. By J. D. Lenk. 502 pp., 424 illus. Here's a special manual to show you how to take off-the-shelf logic circuits and interconnect them to form any logic system you want. Packed with techniques to create superior designs at less cost and with fewer components, this huge manual covers it all—from how to design networks to applying every type of logic device!
784/671 Pub. Pr., \$18.95 Club Pr., \$15.75

HANDBOOK OF OPERATIONAL AMPLIFIER CIRCUIT DESIGN. By D. F. Stout. Edited by M. Kaufman. 434 pp., 223 illus. Compact, concise, highly concentrated, and containing a storehouse of information, this one-stop volume will help you solve any op amp circuit problem!
617/97X Pub. Pr., \$29.65 Club Pr., \$17.50

MICROELECTRONICS Digital and Analog Circuits and Systems By J. Millman. 881 pp., 700 illus. This giant book takes you step by step from a qualitative knowledge of a semi-conductor, to an understanding of the operation of devices, and finally, to an appreciation of how these are combined to form micro-electronic chips.
423/27X Pub. Pr., \$24.50 Club Pr., \$19.50

IC SCHEMATIC SOURCEMASTER. By K. W. Sessions. 557 pp., 1,500 schematics. All 1,500 circuits here—from the simplest to the most complex—are based on currently manufactured, inexpensively acquired ICs. Many are the equivalent of even more complex circuits containing up to several thousands of individual transistors if built with discrete components.
784/922 Pub. Pr., \$26.95 Club Pr., \$19.95

ELECTRONICS ENGINEER'S HANDBOOK. Editor-in-Chief, D. G. Fink. 2,104 pp., 2,026 illus. Huge in every sense, this instant-reference volume gives you every latest essential in the field, 2,100 formulas and equations, a 2,500-item bibliography, and every illustration you need to clarify all of modern electronics!
209/804 Pub. Pr., \$49.50 Club Pr., \$35.00

ELECTRONIC GAMES Design, Programming & Troubleshooting. By Walter H. Buchsbaum and Robert Mauro. 335 pp., 338 illus. The first book to describe the new circuits, designs, and programs so that electronically minded readers will have the latest data and techniques they need in the specialized fields within electronics that make up an electronic game.
087/210 Pub. Pr., \$17.50 Club Pr., \$14.00

STANDARD HANDBOOK OF ENGINEERING CALCULATIONS. By T.G. Hicks. Editor-in-Chief. 1,200 pp., 428 illus. Tells you *what* to do, *when* to do it, and *how* to do it—giving step-by-step solutions to the design and application problems that engineers encounter daily. Containing some 1,000 calculation procedures accompanied by worked-out numerical examples, it also features 4,000 related calculation procedures.
287/341 Pub. Pr., \$27.50 Club Pr., \$19.95

BE SURE TO CONSIDER THESE IMPORTANT TITLES AS WELL:

DESIGN TECHNIQUES FOR ELECTRONIC ENGINEERS. Electronics Magazine. 191/581 Pub. Pr., \$24.50 Club Pr., \$17.50

HANDBOOK FOR ELECTRONICS ENGINEERING TECHNICIANS. By M. Kaufman & A. H. Seidman. 334/013 Pub. Pr., \$23.50 Club Pr., \$16.50

PROFESSIONAL ENGINEERS' EXAMINATION QUESTIONS AND ANSWERS, 3/e. By W. S. LaLonde, Jr. & W. J. Stack-Staikidis. 360/936 Pub. Pr., \$19.50 Club Pr., \$14.50

GUIDEBOOK OF ELECTRONIC CIRCUITS. By J. Markus. 404/453 Pub. Pr., \$37.50 Club Pr., \$27.50

APPLIED ELECTROMAGNETICS By M. A. Pionus 503/451 Pub. Pr., \$24.50 Club Pr., \$16.50

MICROPROCESSOR AND MICROCOMPUTER SYSTEMS. By G. V. Rao. 783/659 Pub. Pr., \$24.50 Club Pr., \$19.50

MICROPROCESSOR APPLICATIONS MANUAL. By Motorola Semiconductor Products, Inc. 435/278 Pub. Pr., \$35.00 Club Pr., \$25.00

POWER TRANSISTOR AND TTL INTEGRATED CIRCUIT APPLICATIONS. Texas Instruments. 637/547 Pub. Pr., \$19.50 Club Pr., \$12.95

CRYSTAL OSCILLATOR DESIGN AND TEMPERATURE COMPENSATION. By M. E. Frerking. 784/973 Pub. Pr., \$16.95 Club Pr., \$13.50

MASTER OP-AMP APPLICATIONS HANDBOOK. By H. W. Fox. 784/477 Pub. Pr., \$16.95 Club Pr., \$13.50

ELECTRONICS DESIGNERS' HANDBOOK. Edited by L. J. Giacoletto. 2nd Ed. 2,344 pp., 1,686 illus. Now doubled in size and with 90% of its material new, this famous classic (first edition by Landee, Davis, Albrecht) has been thoroughly revised and updated to give you not only the *how* and the *why* of your design work but also the *how much* of every design step you take!
231/494 Pub. Pr., \$52.50 Club Pr., \$39.50

DIGITAL INTEGRATED CIRCUITS AND OPERATIONAL AMPLIFIER AND OPTOELECTRONIC CIRCUIT DESIGN. Edited by B. Norris. 206 pp., 400 illus. Having this vast amount of case-tested data, proven shortcuts, worked-out circuit designs, and circuit diagrams handy saves you valuable time for your other, more vital, areas of creative design—and cuts down costs in all areas!
637/539 Pub. Pr., \$19.50 Club Pr., \$14.50

OPTOELECTRONICS Theory and Practice. By Texas Instruments Incorporated. Edited by A. Chappell. 442 pp., 475 illus. Right here is where you'll find all the knowledge and know-how you need to take any of today's optoelectric components and develop your own circuits and uses. You get both the background and the technical specifics (with all the proven circuits you want!)
637/555 Pub. Pr., \$21.50 Club Pr., \$17.00

PRINTED CIRCUITS HANDBOOK, 2/e. By C. F. Coombs, Jr. 256 pp., 327 illus. Blueprints every important phase of printed circuitry. Provides the information you need to establish a production facility and control the processes. A virtual encyclopedia in the field, five major sections cover engineering, fabrication, assembly, soldering, and testing.
126/089 Pub. Pr., \$32.50 Club Pr., \$24.50

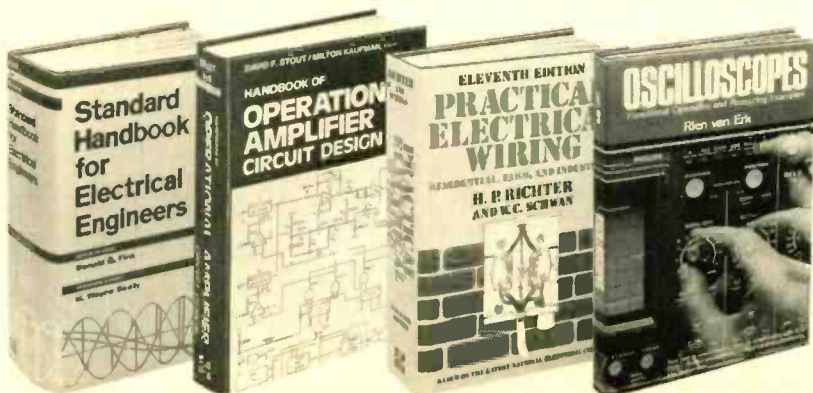

offer to new members of the and Control Engineers' Book Club

McGRAW-HILL DICTIONARY OF PHYSICS AND MATHEMATICS. By the Staff of the McGraw-Hill Encyclopedia of Science and Technology. D. N. Lapedes, Editor in Chief. 1,074 pp., 700 illus. Look no further! Here are more than 20,000 physics and math terms, including those used in 53 related disciplines ranging from acoustics and control systems to electronics and thermodynamics! 454/809 Pub. Pr., \$19.95 Club Pr., \$16.25

PRACTICAL ELECTRICAL WIRING Residential, Farm, and Industrial, 11/e. By H. P. Richter; revised by W. C. Schwan. 664 pp., 455 illus. As you know, code-correct wiring is a must at all times. And as you also know, Richter's famous classic for professional electricians reflects in detail all the changes and all the advances in materials and techniques in each new edition *everytime a new Code is published!* 523/886 Pub. Pr., \$18.00 Club Pr., \$14.00

STANDARD HANDBOOK FOR ELECTRICAL ENGINEERS, 11/e. By D. G. Fink and H. W. Beaty. 448 pp., 1,414 illus. A giant in every sense of the word, today's most widely used source of electrical engineering information and data serves you as no other single work available anywhere when you need detailed, accurate, timely, and reliable facts and how-to on the generation, transmission, distribution, control, conversion, and application of electric power. 209/74X Pub. Pr., \$46.50 Club Pr., \$36.50

ROTATING ELECTRIC MACHINERY AND TRANSFORMER TECHNOLOGY. By D. V. Richardson. 615 pp., illus. The entire emphasis is practical in this all-inclusive book, which takes an algebraic approach to the subject and includes both the English and unified SI units information for all tables and charts. Questions and problems at ends of chapters ensure your confident use of each type of machine and transformer covered. 784/884 Pub. Pr., \$19.95 Club Pr., \$16.50

MICROPROCESSORS & SMALL DIGITAL COMPUTER SYSTEMS FOR ENGINEERS & SCIENTISTS. By G. A. Korn. 390 pp. This exceptional book is your quick reference for expert advice on product selection, interfacing, and programming. Containing a huge variety of computer possibilities, system features, and costs, it's also a terrific tool for career updating. 353/670 Pub. Pr., \$27.50 Club Pr., \$18.95

ELECTRONICS DICTIONARY. Edited by John Markus. 4th Ed., 768 pp., 1,173 illus., 17,090 terms. With the new edition of this world-renowned dictionary you'll be able to quickly find the meaning and correct usage of any electronics term, no matter how obscure! 404/313 Pub. Pr., \$24.50 Club Pr., \$19.50

MAGNETIC BUBBLE TECHNOLOGY. By H. Chang. 117 pp., illus. The advent of bubble storage packages on the market has had a profound effect on the computer memory business. And here's an in-depth assessment of the technology and the possibilities for future development. 785/783 Pub. Pr., \$19.50 Club Pr., \$15.75

OSCILLOSCOPES. Applications and Uses in Electronics. By R. Van Erk. 270 pp., 248 photos and diagrams. The amount of technical information it contains is stupendous, beginning with the oscilloscope's basic operations (plus additional features and their functions) and continuing with the special oscilloscopes and variants, oscilloscope probes, and measurement pitfalls. 670/501 Pub. Pr., \$16.50 Club Pr., \$13.50

MICROCOMPUTER-BASED DESIGN By J. B. Peatman. Expanded 4th printing, 604 pp., over 400 photos and other illustrations. Do all your best day-to-day designs, as well as your supercreative and special designs, around the new microcomputers and the specific "how-to" help you get here! 491/380 Pub. Pr., \$26.50 Club Pr., \$18.95

ELECTRONICS AND CONTROL ENGINEERS' BOOK CLUB saves you both time and money!

Here is a professional book club designed to meet your on-the-job engineering needs by providing practical books in your field on a regular basis at *below publisher prices*. If you're missing out on important technical literature—if today's high cost of reading curbs the growth of your library—here's the solution to your problem.

The *Electronics and Control Engineers' Book Club* was organized for you, to provide an economical reading program that cannot fail to be of value. Administered by the McGraw-Hill Book Company, all books are chosen by qualified editors and consultants. Their understanding of the standards and values of the literature in your field guarantees the appropriateness of the selections.

How the club operates: Thirteen times a year you receive free of charge *The Electronics and Control Engineers' Book Club Bulletin*. This announces and describes the Club's featured book for that period as well as alternate selections available at special members' prices. If you want to examine the Club's featured selection, you do nothing. If you prefer one of the alternate selections—or if you want no book at all—you notify the Club by returning the card enclosed with each Bulletin.

As a Club member, you agree only to the purchase of four books (including your first selection) over a two-year period. Considering the many books published annually, there will surely be at least four you would want to own anyway. By joining the Club, you save both money and the trouble of searching for the best books.

any one
of these great
professional books
for **\$1.89**
only
values up
to \$52.50

Special \$1.89 bonus
book comes to you
with your first
club selection

Books are selected from a wide range of publishers

MAIL COUPON TODAY

ELECTRONICS AND CONTROL ENGINEERS' BOOK CLUB
P.O. Box 582, Hightstown, New Jersey 08520

Please enroll me as a member and send me the two books indicated. I am to receive the bonus book at the introductory price of \$1.89 plus my first selection, plus tax, postage and handling. If not completely satisfied, I may return the books within 10 days and request that my membership be cancelled. If I keep the books, I agree to take a minimum of three additional books during the next two years at special Club prices (guaranteed 15% discount, often more). I will receive the Club Bulletin 13 times a year. If I want to examine the featured selection, I need take no action. It will be shipped automatically. If, however, I want an alternate selection—or no book at all—I simply notify the Club by returning the convenient card always enclosed. I will always have a minimum of ten days in which to return the card and you will credit my account fully, including postage. If this is not the case, Membership in the Club is continuous but cancellable by me at any time after the four-book purchase requirement has been filled. *This order subject to acceptance by McGraw-Hill. Orders from outside the continental U.S. must be prepaid. All prices subject to change without notice. Offer good for new members only. Postage and handling charges are added to all subsequent shipments.*

WRITE BELOW:

Code No. of \$1.89 book _____ Code # of 1st selection _____

NAME _____

ADDRESS _____

CITY _____

STATE _____ ZIP _____

EXTRA SAVINGS: Remit in full with your order, plus any local and state tax, and McGraw-Hill will pay all regular postage and handling charges.

E33375

Equip yourself with the best.

PTS 8001 Component Analyzer

Solid state component tester works in or out of the circuit. Simple hook-up to any standard oscilloscope. High, medium and low range switch for matching the impedance of the component being tested.



PTS DG-1 Digital Power Supply

External variable power supply for substituting voltages in televisions, stereos, radios, computers, microprocessors, appliances, CB equipment, telephone equipment, electronic cash registers, security systems and other electronic devices.



PTS DG-4 Voltage Control Center/ Digital Power Supply

Independently produces four variable DC supply voltages. Excellent for substituting critical control voltages for TV electronic/varactor tuners. All units come in vinyl cabinet in optional walnut, black or blue and carry a one year limited warranty.



These products available from any PTS stocking distributor as well as PTS tuner/module servicers. Check the yellow pages for the servicer nearest you.



PTS ELECTRONICS, INC.
The Only Name You Need To Know

Make America smarter.
Give to the college of your choice.

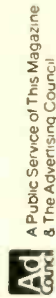

Council for Financial Aid to Education, Inc.
680 Fifth Avenue New York, N.Y. 10019

THE BIG PLUS + Graphic Equalizer

ASSEMBLED
\$189⁹⁵

KIT
\$99⁹⁵



LOADED with Quality Features!

- Stereo . . . Eleven Bands Per Channel • Extremely Low Noise & Distortion • LED Peak Indicators • Center Detent ("flat") sliders • Built-in "record" Switching • Line and Microphone Level Inputs/Outputs • Regulated Power Supply • Fully Guaranteed • Horizontal or Vertical Cabinets • Kit or Fully Assembled • Plus Much, Much More!

Absolutely equals or exceeds overall performance and features of any graphic equalizer made today!

AARON-GAVIN INSTRUMENTS, INC.

17231 Corla Avenue Tustin, California 92680

Yes! I've enclosed \$ _____; RUSH me: assembled equalizers at \$189.95, p.p.d. cabinet send brochure
 unassembled equalizer kits at \$99.95, p.p.d. Horizontal (flat) Vertical (up-right)
 California residents include 6% sales tax Visa & Master Charge orders accepted

Name _____ Card No. _____
 Address _____ Exp. Date _____ Bank No. _____
 City _____ State _____ Zip _____

Dealer inquiries invited

CIRCLE 5 ON FREE INFORMATION CARD

COMPUTER CORNER
continued from page 87

counters. A series of switches allowed presetting the starting address at which the block of data was to be stored. Once a complete block of data was accumulated in the 256-byte long FIFO memory, external circuitry was used to detect the FIFO FULL condition, and to initiate the request for the use of the bus, asserting the HOLD line to the 8080. When the 8080 acknowledged the HOLD mode with the HLDA signal, the data was transferred from the FIFO memory to the microcomputer's main read/write memory at a rate of 500K bytes-per-second, or one byte every 2 μ s. This data-transfer rate could have been increased at least fourfold, but it was unnecessary in this particular case.

Figure 1 is the block diagram of the interface that was used to control the DMA data transfers.

The DMA interfacing technique is also used in front-panel control circuits. Control panels are often provided on microcomputers so that memory locations can be addressed and the user can examine their content. The user may elect to "deposit" new data in one or more memory locations, again through via a front panel. A simple front-panel control system is easily constructed using the DMA technique,
continued on page 96



Using a computer is easy... for **onComputing** readers.

Read **onComputing** to find out . . .

- What a micro-computer can do
- How to get started
- What's new in personal computers
- Where to buy your computer
- How to use your computer

The editors of **onComputing** realize that much of the material written about computers is not at all suited to the person who just wants to use a computer as a tool for business, education, home entertainment, laboratory work, or other applications. **onComputing** is dedicated to helping the computer user understand the capabilities of a microcomputer—in non-technical language.

onComputing is entertaining and informative. It contains practical articles on how to get started, including what you'll need for your application and what it will cost. It features book reviews, product reviews, information on what's

new in personal computers, where to buy a personal computer, and—how to use it.

onComputing is a totally new publication. It is issued quarterly and contains articles from some of the best known names as well as from competent amateurs. It is edited and produced under the guidance of an experienced staff of computer experts. The articles in **onComputing** have never appeared in any other publication. They are all fresh, informative, and valuable reading for anyone interested in using a computer—for fun or profit!

onComputing[™]
GUIDE TO PERSONAL COMPUTING

Start your subscription today.

CIRCLE 20 ON FREE INFORMATION CARD

EVERY THREE MONTHS **onComputing** will bring the latest developments in the field of personal computing: use, applications, books, selection—all in an easy-to-read style.

© onComputing, Inc. 1979

onComputing Subscription Department, P.O. Box 307, Martinsville, NJ 08836

CHARTER subscription rate in effect during introductory period (April–May 31, 1979)

U.S. 1 yr. (4 issues) @ \$7.50 Canada & Mexico 1 yr. (4 issues) @ \$9.00

REGULAR subscription rate applies to all subscription cards postmarked after May 31, 1979

U.S. 1 yr. (4 issues) @ \$8.50 Canada & Mexico 1 yr. (4 issues) @ \$10.00

FOREIGN (to expedite service, please remit in U.S. funds drawn on a U.S. bank.)

Europe (and all other countries, except above) 1 yr. @ \$12.00—surface delivery

Bill VISA Bill Master Charge Bill me (North America only)

Charge Card Number _____ Expiration _____

Signature _____ Name (Please print) _____

Street/Apartment Number _____

City _____ State/Province/Country _____ Postal Code _____

7859

state of solid state

The mysterious I²L logic process revealed. Plus new semiconductor announcements. **KARL SAVON**, SEMICONDUCTOR EDITOR

AS NEW INTEGRATED-CIRCUIT TECHNIQUES evolve, terms are invented to go with them. Integrated Injection Logic (I²L) is one such term that, at first hearing, is enough to frighten anyone off. But I²L turns out to be not as ominous as it sounds, and, in fact, is a neat, valuable technique that leads to compact, moderate-speed logic applications. Another attraction of I²L is that the injector voltage (the highest voltage with the IC) is only about 0.75. The result is a very low power dissipation per gate.

The processing steps leading to a finished I²L circuit are nearly identical to those used to build conventional monolithic bipolar IC's, even to the extent that bipolar and I²L circuitry can be combined on the same monolithic substrate. Therefore, let's start by reviewing the conventional bipolar IC process.

Figure 1 shows the cross-section of a conventional integrated NPN transistor. The process of building this transistor starts with slicing a thin wafer of silicon from an ingot. After the wafer has been polished to a mirror finish, a layer of silicon dioxide is formed by heat and oxygen on the wafer surface. Throughout the process, windows are etched through the oxide layer to allow the selective diffusing of defined areas. Photomasks are used to superimpose a pattern of photoresist material on top of the oxide. The areas that are not covered with resist are unprotected and are removed by acid. The initial wafer material forms the P-type substrate shown at the bottom of Fig. 1.

The next series of steps involves diffusing N+ pockets. These low-resistance pockets are covered by the layer described in the next step, which is also referred to as the buried layer.

An epitaxial layer is grown on top of the substrate into which the remaining diffusions will go. To isolate the transistors from each other, their epi (or collector) areas must be separated. The P+-isolation regions are diffused into the epi layer, dividing it into islands.

The transistor bases are then formed with a P-diffusion into the subregions of the collectors. This identical diffusion step also forms resistors, with their characteristic resistivity of around 200 ohms-

per-square. Then, N+ emitter and collector contacts are added and openings are formed for contacting the aluminum interconnecting metal that follows in the next step.

Metallization is formed by wiring that connects the various IC devices in their predetermined pattern. It is deposited on the surface and alloyed to the semiconductor material under the contact openings.

Finishing the passivation, bonding and packaging steps complete the multistep procedure.

strate-collector diodes.

What happens if the collector and emitter functions are reversed? If the collector is connected in place of the emitter in a circuit and vice versa, this inverted transistor still acts as a transistor. However, the nonsymmetrical geometrical layout causes the inverted beta (current-gain) to be lower than the noninverted beta, as well as some other parameter differences. However, especially configured digital circuits, the inverted transistor performs satisfactorily.

The inverted transistor is the "trick" to I²L. If the noninverted N+ emitter regions are used as collectors and the N-collector region is grounded, many transistors can be built into a single isolated

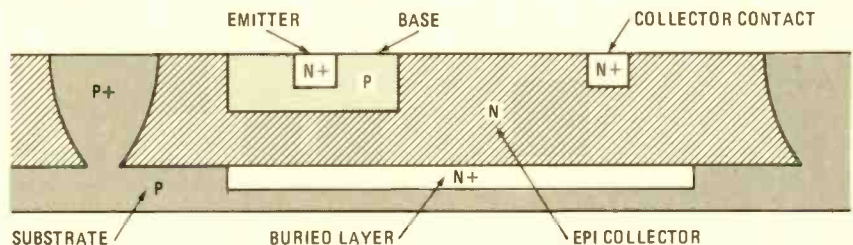

FIG. 1

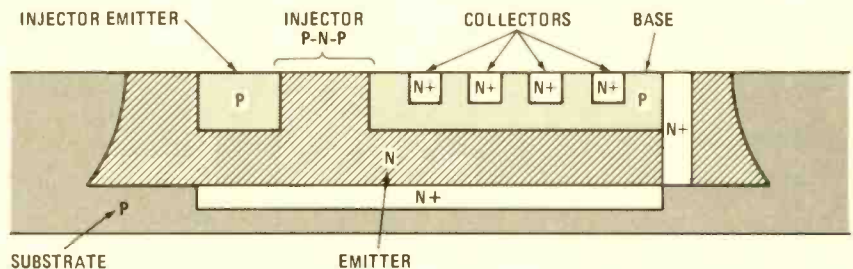

FIG. 2

Figure 1 shows that NPN bipolar transistors have two semiconductor junctions—the base-to-emitter junction between the emitter N+ and base P-regions, and the collector-base junction between the P-base and N-collector regions. In normal transistor operation, the base-to-emitter junction is forward-biased and the base-collector junction is reverse-biased.

The junction between the N collector and P substrate is reverse-biased and forms a nonconductive diode that is the actual isolation mechanism between transistors. The substrate is usually grounded, and the transistor elements are biased at or above ground, thus inhibiting the sub-

region, as shown in Fig. 2.

Figure 3 shows a single I²L transistor stage that consists of an inverted transistor and a base-current source. The current source is the so-called injector, which is actually a PNP transistor. All the PNP emitters on the IC are connected to a common input pin, and sometimes form a long P-diffusion up and down the IC. The pin is connected through an external resistor to a more positive voltage source determining the total current drain of the IC. Each individual PNP transistor then supplies a portion of the total injector current to its particular NPN base. In Fig. 2, note the PNP injector transistor formed by the junction

PLUG IT IN AND TAKE COMMAND



X-10 Remote Control For Lights and Appliances

NO WIRES NO HASSLES

System X-10 requires no special wiring or complicated installation. Simply plug the Command Console into your wall outlet in any desired location in your home. Plug each lamp or appliance into the appropriate module and then plug that module into any wall outlet. Any number of command consoles may be used in a single system.

TOTAL CONVENIENCE

With System X-10 at your side, you can operate almost every light and electrical appliance in your home without leaving the comfort of your easy chair. Imagine turning on a TV set or stereo; even dimming a light in the next room without moving from your chair.

It may sound like one of those electronic devices found in a spy thriller, but you can have one today.

And how many times have you left a light or an electrical appliance on overnight simply because you were too tired or too lazy to turn it off? Think of the money you can save on electric bills with System X-10. Turn off heaters or appliances from any location in your home without a lot of running around.

MICROPROCESSOR BASED DESIGN

The BSR X-10 System uses the latest digital techniques for trouble-free operation. Digital pulse codes are sent through the power lines to assure reliable control throughout the system. Amazingly compact, the command console is only 4¾" X 3½" X 3½".

LAMP MODULE

Each module will control any incandescent lamp rated up to 300 watts from control signals received from the Command Console. Functions include on and off, brighter and dim. UL listed.

APPLIANCE MODULE

Each module receives signals from the Command Console to turn appliances on and off; such as TV, stereo, fan, etc. Maximum appliance ratings: Resistive load—15 amps., Motor load—1/3 HP, Incandescent Lamp—500 wats. UL listed.

GETTING STARTED

Basic starter kit includes: 1—Command Console, 2—Lamp Modules, 1—Appliance Module. Only \$87.95 plus \$3.00 shipping and handling. Extra Lamp and Appliance Modules \$16.00 each. Extra Command Consoles \$39.95 each.

ADVANCE ELECTRONICS 

To order—use this coupon or call
TOLL FREE HOT LINE
800-223-0474

54 West 45 Street, New York, N.Y. 10036

IN NEW YORK STATE 212-687-2224

Please send me
 BSR X-10 System 4 piece starter kit @ \$87.95 set
 Lamp Modules @ \$16.00 each
 Appliance Modules @ \$16.00 each
 Command Consoles @ \$39.95 each

Payment enclosed Bill my MASTER CHARGE VISA

Acct # _____ Exp. Date _____

Name _____

Address _____

City _____ State _____ Zip _____

Add \$3.00 Shipping and Handling. N.Y.S. add sales tax.

The Understanding Series™ from Texas Instruments.

Five self-paced, easy-to-understand books for the reader who wants to learn about electronics technology, but can't devote years to the study.



Understanding Microprocessors. 250 pages. Available June 1979. For the newcomer to microprocessors. What they are, what they do, how they work.



Understanding Calculator Math. 224 pages. Loaded with practical electronic calculator applications.



Understanding Solid-State Electronics. New 3rd edition. 270 pages. Simple building blocks for learning solid-state behavior.



Understanding Digital Electronics. 265 pages. The world of today's digital devices made easy.



Basic Electricity and DC Circuits. 1026 pages. Learn all about DC Circuits—simply, easily.

<input type="checkbox"/> LCB-4023 Understanding Microprocessors. New... available June 1979	\$ 4.95	Mail check or money order to Texas Instruments. P.O. Box 3640, M/S84, Dallas, Texas 75285. Orders in Continental U.S. shipped prepaid. Foreign orders: Prepaid funds in U.S. dollars only. Include shipping costs.	
<input type="checkbox"/> LCB-3321 Understanding Calculator Math	\$ 3.95		
<input type="checkbox"/> LCB-3361 Understanding Solid-State Electronics. New 3rd edition	\$ 3.95		
<input type="checkbox"/> LCB-3311 Understanding Digital Electronics	\$ 3.95		
<input type="checkbox"/> LCW8161 Basic Electricity and DC Circuits	\$19.95		
Add applicable sales tax (except AK, DE, HI, MT, NH, OR)		Name _____ Address _____ City _____ State _____ Zip _____	
SPECIAL OFFER		Limited time offer. Prices effective January, 1979. Subject to change without notice.	
Purchase any two books and save		\$ 5.00	© 1979 Texas Instruments Incorporated
Purchase all five and save		\$2.00	
TEXAS INSTRUMENTS		RE579	
INCORPORATED			

instead of automotive points. The addition of the MJ10012, a Darlington driver transistor, to supply the high-energy ignition coil plus some resistors and capacitors complete the ignition system. The circuit operates from battery voltages from 4 to 24. Dwelltime and overvoltage shutdown are externally programmable.

Motorola Semiconductor Products, Inc., P.O. Box 20912, Phoenix, AZ 85036.

New power devices

The RCA 9113 NPN power-transistor series is designed for high-voltage switching applications. Its specific uses are for switch-mode power supplies, inverters, converters, pulse-width-modulated regulators and motor controls. These transistors are rated to 400 volts V_{CE0} and have switching speeds in the range of 1 μ s. RCA Solid State Division, Box 3200, Somerville, NJ 08876.

Hitachi has developed complementary power audio-equipment MOSFET's that it expects to market at the end of the year as the models HS8401 and HS8402.

Newly developed technology such as ion implantation adds the high-voltage and high gain necessary in power amps. The company claims these devices have greater frequency response and reliability compared with conventional power transistors. Their high-speed switching capability reduces distortion and dissipation to a greater degree than bipolar transistors. **R-E**

between the injector emitter and the N region, and the junction between the N region and the base of the NPN.

The current sources serve as high impedances to the driving collectors. This very efficient arrangement allows compact use of the IC area because of the numerous devices contained in a single N-isolated area compared with the noninverted single transistor-per-collector isolation ratio. In addition, because of the injector PNP current sources, there is a complete absence of resistors in this logic scheme.

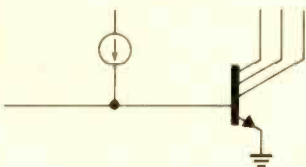

FIG. 3

The deep N+ region shown at the extreme right of Fig. 2 does not have a counterpart in the conventional transistor shown in Fig. 1. This area is a guard band that prevents parasitic currents from flowing to the wrong places.

We can now see how inverted transistors are used to implement a typical logic function. Figure 4 shows how output currents from several collectors are summed by simply connecting them to-

gether at the base of a transistor. Along with the inverter transistor, this connection creates a wired NAND gate. If currents i_1 , i_2 and i_3 are all 0, current source I_1 turns on Q4 and its output voltage is 0.

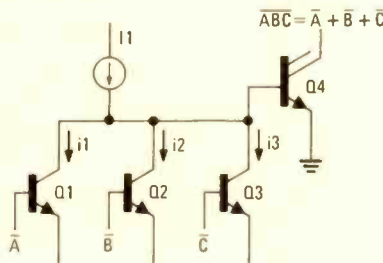

FIG. 4

If any of the three input currents is nonzero, Q4 is turned off and its collector swings high. In other words, current i_1 , i_2 or i_3 switches Q4's collector low. Using inverter transistors Q1, Q2 and Q3 creates an AND function. Assume the inputs to the transistors are A, B and C. Their collector currents are summed at the base of Q4, which swings high only when the three driving transistors are off—this is the AND function. You'll also observe that the NAND function, \overline{ABC} , is equivalent to $A + B + C$.

Ignition circuit

Motorola's MC3333 *Vari-Dwell* ignition circuit uses a flux-averaging sensor

COMPUTER CORNER

continued from page 92

since a 16-bit three-state buffer can be used to supply the address and eight indicators can be used to show the state of each bit in the memory location addressed. Eight logic switches are used to load new data into a location and two control switches, EXAMINE and DEPOSIT, are configured to generate the memory-read and memory-write control pulses, respectively. Additional features can be added to such a simple control circuit to automatically increment or decrement the 16-bit memory address, etc.

There are, however, some words of caution that must be noted when considering the use of DMA. The 8080 microprocessors are locked out of performing any program steps while they are in the HOLD state.

Some microprocessors such as the MC6800 series require that DMA-based devices regularly relinquish control of the bus. The three-state control (TSC) line in 6800-based systems can only be asserted for periods of 5 μ s at a time. Similarly, in systems that use dynamic read/write memory devices, the address and data buses cannot be used continuously by DMA-based devices for more than 1 ms or so. **R-E**

NEXT BEST THING TO BEING THERE!



With your own tutor, electronics naturally seems easier, more understandable. Now these unique training aids bring you friendly, over-the-shoulder, hands-on guidance, as if you had an expert right beside you. All planned and prepared in our effective Easi-Way™ teaching style. Only face-to-face instruction could be more personal. Nothing else like these...anywhere!

Two Forest Belt's Service Training MONOGRAPHS:

"TRIGGERED OSCILLOSCOPES—Four Hours to Familiarity"

Sit down in front of your triggered scope 30 minutes a day, and go through carefully organized exercises. In less than two weeks, you can truly UNDERSTAND how your scope displays signal waveforms; where to set the knobs and switches; what waveshapes mean; what to do when you can't seem to get a display on your scope. End up feeling comfortable and self-assured with any triggered oscilloscope.

Order 48A - \$12.50 postpaid

P.S.—The above title is available also as a Forest Belt's **SELF-TRAINER KIT**: two audio cassettes plus a dozen sets of Worksheets (for a group).

Order 48K - \$ 79.50 postpaid

Additional Worksheets Order 48W - Ten for \$ 25.50

"Easi-Way™ Solutions for Electronics Math and Formulas"

Spend a half-hour each day with your inexpensive scientific calculator (many models under \$40). Learn quickly to solve electronic formulas without knowing algebra. Thorough Easi-Read™ explanations, plus dozens of planned examples and exercises for you to work yourself. Shows you how to deal with Ohm's Law, Kirchhoff's Laws, series and parallel circuits, reactance, impedance, resonance, decibels, and plenty more. Handle complex math easier than you ever thought possible.

Order 28A - \$ 12.50 postpaid

Scientific Calculator

Order 28SC \$ 35.50 postpaid

Enclosed in my \$ _____ check or money order (outside U.S., add 20% to all prices). Please ship:

_____ MONOGRAPH 28A "Easi-Way™ Solutions for Electronics Math and Formulas" @ \$ 12.50 each

_____ Scientific Calculator 28SC (suits use with 28A) @ \$ 35.50 each

_____ MONOGRAPH 48A "TRIGGERED OSCILLOSCOPES—Four Hours to Familiarity" @ \$ 12.50 each

_____ SELF-TRAINER KIT 48K "TRIGGERED OSCILLOSCOPES—Four Hours to Familiarity" @ \$ 79.50 each kit

_____ Additional Worksheets 48W (for larger groups to use with KIT) @ \$ 25.50 for ten

My name is _____ Age _____

Address _____ Phone _____

City _____ State _____ Zip Code _____

Forest Belt's Service Training MONOGRAPHS
Box 68120 Indianapolis IN 46268

service clinic

Fast-recovery diodes and DC power supplies can cause many troubleshooting headaches. JACK DARR, SERVICE EDITOR

I'VE USED THE MATERIAL IN THIS COLUMN before. This concerns two items that have been discussed at length. Still, I keep getting far too many letters from technicians who obviously have not gotten the word. So, I'm going to run it by again and hope that we will be able to reach a few more people who can use the information.

Fast-recovery diodes

The first item concerns the fast-recovery diode. This diode is a special type that turns off very rapidly. So, this is the type we must *always* use as a replacement in any kind of DC power supply that is fed by horizontal-frequency pulses (i.e., a flyback-derived DC supply). Conventional silicon diodes are sinewave diodes and work fine for a 60-Hz sinewave or pulse. However, when these standard types are used in a flyback-derived power supply, the input is a very sharp high-frequency pulse, and conventional diodes simply will not turn off fast enough. So they draw a very high reverse current. If you've changed a diode and the new one blows up in about 25 to 30 seconds, look out! This is the typical symptom of using the wrong type of diode.

Use a fast-acting diode in *all sets* using flyback-derived power supplies even the Quasar *Electronic Power Supply* that operates at 15,750 Hz, and is synchronized by flyback pulses. Unless you are absolutely *sure* that the AC power supply to the diode is a 60-Hz sinewave, it is best to use a fast-recovery diode. Incidentally, a fast-recovery diode works on a 60-Hz supply, but not the reverse—It's a one-way street.

In checking any transistor replacement guide, you'll find lots of fast-recovery diode types listed. Every manufacturer has at least one, and some have five or six types. Typical specs for these diodes show a recovery time of 0.5 μ s. Even on a very sharp pulse, a fast-recovery diode turns off completely and does not draw reverse current.

DC power supplies

The second item for discussion is a kind of dual problem in itself that has also drawn a lot of mail. For many years, I

(along with many others) have been hollering "Check the B+!" (And this goes back as far as radio days!) It's *still* the *very first step* that should be taken in any kind of electronic troubleshooting. The reasoning is simple: If the B+ DC voltage supply is off, nothing will work until that is fixed. Also, statistically speaking, DC power supplies cause the most trouble of any section of the TV set.

So, when starting your analysis of a problem, make *sure* that all the DC power supplies are in the ballpark. In a solid-state color TV set, there may be four or five such supplies and they are all critical. Any trouble in here can cause all kinds of problems.

Secondly, there are two circuits in solid-state TV sets that interact—the DC voltage regulators, of which there may be several; and (linked with these) the numerous shut-down circuits. These circuits can kill everything if the high voltage or the low DC voltages exceed normal levels. If a voltage regulator is not working properly, the DC voltage rises, the shutdown fires and out it goes.

So, voltage regulators should always be checked for correct output. Most regulators are held to very tight tolerances. If the schematic calls for +69.5 volts, you'd better not get a reading less than +69 volts or more than +70 volts. If the regulators are using a pass transistor that is either leaky or shorted, the output voltage will rise to the supply level. Instead of +69.5 volts, you may read +90 volts or more. This voltage will trigger the shut-down circuit. If it doesn't the high voltage can go up to amazing levels, and a perfectly good horizontal-output transistor can be destroyed.

A simple test for this is to plug the set into a Variac. Monitor the DC voltage supply at a key point. Bring the line voltage up until the DC voltage reads exactly what it is supposed to—+69.5 volts or whatever the schematic calls for. In a lot of cases, you may find that the set starts working very well; I have. If this happens and the input voltage is quite a bit *below* normal, this is a very good hint that one of the voltage regulators is not working. If so, the problem is in the DC voltage regulator and nowhere else.

Ordinarily, these circuits are fairly simple to check. Look for shorted or leaky pass transistors, shorted or leaky drivers, error amps, and especially in one of the Zener diodes that are used as clamps in the regulator circuits. If the voltage across a Zener diode is not correct to within $\pm 5\%$, check it or change it.

I hope that this reminder will get the message across to some who didn't get it the first time around. It saves a lot of time and trouble! R-E

service questions

HIGH VOLTAGE DOWN

A model TAC-3310 Toshiba has turned into a tough nut. A couple of new tubes, including a new horizontal output, cured the original problems, but the picture is still too dark, and the high voltage is only 11 to 13 kilovolts depending on the brightness-control setting. Nothing is smoking. The boost is low. I'm checking it on a test rig. The grid waveform on HOT is OK; so is the analyst plate drive.—R. T., Louisville, KY.

My reply to this problem began with some general suggestions. Then I wrote him, "Something's nudging me! You're using this on a test rig; your boost is low, etc. *Maybe* the horizontal yoke winding of the test rig doesn't quite match this set! If so, you would get these kinds of symptoms."

(Feedback: "Bingo! That was a good nudge. I used extension cables, hooked the Toshiba set to its own yoke/CRT, and everything fell into place. The high voltage and boost went up, the brightness was OK, and so on. I happened to notice that when the 21JZ6 screen went up to +105 volts, on the test jig it was also quite a bit lower.")

ODD COLOR PROBLEM

I get good color bars and a good vectorscope pattern on this Zenith model 25MC30. But . . . if I hook the set up to an antenna, there's no color at all! I thought of using alignment, but this seems unnecessary with the good color bars and vectorscope output. What goes?—J. U., Beaverton, OR.

Learn MICROPROCESSOR OPERATION, INTERFACING and PROGRAMMING faster, easier and at less cost with the HEATHKIT® Microprocessor Self-Instruction Program and Computer Trainer

Here's the newest, easiest and lowest-cost self-instruction microprocessor program ever! What's more, it's the fastest way to really learn about this fascinating field with applications in every phase of our everyday lives. From automotive diagnostics to the microwave oven in the kitchen to the computers that are taking on more jobs in the home, schools, government, business and industry every day!

Working with the popular 6800 microprocessor, you'll explore this exciting field using proven self-instruction text materials. You'll learn about micro-computer basics, number systems and codes, computer arithmetic, programming, 6800 capabilities and interfacing and more. With the aid of audio visuals included, you'll go deeper into programming, designing with microprocessors and semiconductor memories. And you'll actually perform a whole series of "hands on" experiments with the optional trainer designed to reinforce the theory you've mastered to that point!

The ET-3400 Trainer kit, designed to accompany your program, features the popular 6800 microprocessor. It is actually a miniature digital computer in itself, complete with a: 1K ROM monitor program; 6 digit LED display for address and data readout; 17-key hexadecimal keyboard for entering programs, data and control; 256 bytes of RAM (expandable to 512 bytes with the chips supplied in the course); breadboarding socket; 8 buffered LED's for display of logic states; 8 SPST switches for binary input plus an on-board power supply with +5, +12 and -12 volt outputs.

The Program comes complete with 62 electronic components, including a 6820 PIA, two 2112 RAM's, a 1406 digital-to-analog converter, 741 and 301 op amps and more. Includes audio visual aids such as an audio cassette, colorful flip charts and programmed learning text material in two deluxe permanent binders.

Complete the optional exam and receive a Certificate of Achievement and 8.0 Continuing Education Units (CEU's) — a nationally accepted means of recognizing participation in non-credit adult education. (Note: Microprocessor Program requires completion of Digital Techniques Program or equivalent knowledge.)

ORDER ETS-3400 (Program and Trainer kit) **\$269⁹⁵**
(Add \$4.54 shipping and handling)

MONEY-BACK GUARANTEE!
If you are not 100% satisfied with your Heathkit Program, we will refund the full purchase price of the program text material, less trainer.



FOR THOSE WHO NEED DIGITAL TECHNIQUES TRAINING...

Comprehensive Digital Techniques Program — the background you need to understand computer and modern electronic technology! Digital fundamentals, semiconductor devices for digital applications, Boolean algebra, flip-flops and registers, sequential and combinational logic circuits, digital design and an introduction to computers and more! The program includes programmed instruction text, audio-visual aids, parts for experiments and more. The program includes programmed instruction text, audio-visual aids, parts for experiments and more. Digital Design Experimenter/Trainer lets you perform all the experiments in the program, then develop and test your own projects. Features solderless breadboard sockets, 4 binary data switches, 2 "no bounce" switches to pulse logic circuits, 3-frequency pulse clock generators, 4 LED's for visual indication of logic states plus 3 regulated power supplies. Upon completion of the optional final exam, you receive a Certificate of Achievement and 4.0 Continuing Education Units.

ORDER EES-3201 (Program and Trainer Kit) **\$129⁹⁵**
(Add \$3.94 shipping and handling)

SAVE TIME



ORDER BY PHONE!
Call (616) 982-3411
anytime day or night

HEATH Schlumberger	Heath Company, Dept. 020-532 Benton Harbor, Michigan 49022
Gentlemen: Please send me the item(s) checked below and include my FREE Soldering Iron (GDP-1105).	
<input type="checkbox"/>	Microprocessor Program and Trainer Kit (ETS-3400) \$269.95 (+ \$4.54 shipping & handling)
<input type="checkbox"/>	Microprocessor Program only (EE-3401) \$89.95 (+ \$3.09 shipping & handling)
<input type="checkbox"/>	Digital Techniques Program and Trainer Kit (EES-3201) \$129.95 (+ \$3.94 shipping & handling)
I enclose <input type="checkbox"/> check <input type="checkbox"/> money order for \$ _____; OR, (Michigan residents, add 4% sales tax)	
CHARGE to my <input type="checkbox"/> VISA/BankAmericard <input type="checkbox"/> Master Charge	
Account # _____	Exp. Date _____
Master Charge Code # _____	
Signature _____ (Necessary to send merchandise)	
NAME _____ (Please print)	
ADDRESS _____	
CITY _____	STATE _____ ZIP _____
Prices and specifications subject to change without notice. Prices are mail order net F.O.B. Benton Harbor, Michigan. ED-121	

ORDER YOUR PROGRAM WITHIN THE NEXT 30 DAYS AND GET THIS BONUS

FREE SOLDIERING IRON!

A Comparable \$7.95 Value!

MAIL COUPON TODAY!

Accurate in RF fields!

B&K-PRECISION portable and lab DMM's

For field or lab applications, your DMM should stay accurate—even in the presence of strong RF fields. Most DMMs can't pass this test, but the B&K-PRECISION 2830 lab DMM and the 2810 portable DMM easily meet the challenge.

In addition, both of these instruments feature 3½ digit readout, 0.5% DC accuracy, auto-zeroing/auto polarity, selectable high-/low power ohms and really complete overload protection. Special features of each include:



Model 2830—\$235

- AC operation; battery pack optional
- 100 μ V, 100nA, .01 Ω resolution
- Reads to 20 amps
- Push button range and function selection
- 0.5" high efficiency LED display

Model 2810—\$130

- Battery operation standard
- 100 μ V, .01 Ω resolution
- AC charger optional
- Bright .3" LED display



Available for immediate delivery at your local B&K-PRECISION distributor

BK PRECISION DYNASCAN CORPORATION

6460 West Cortland Street
Chicago, Illinois 60635 • 312/889-9087

In Canada: Atlas Electronics, Ontario
Int'l. Sls: Empire Exp. 270 Newtown Rd., Plainview, L.J. NY 11803

CIRCLE 43 ON FREE INFORMATION CARD

I hate to say it but there's only one thing *left* that could be causing this. With the results you're getting from test signals, it could be there are problems in the *color-killer*. Check the grid voltage on the second bandpass amplifier; the schematic shows this as -30 volts, which signifies no signal or "killed" bias.

One thing used to cause us some odd problems—the 6JU8 quad-diode tube. This is used as the automatic frequency phase control and the killer detector. These tubes developed odd-ball leakages that upset things for three feet in all directions. Try a new 6JU8 first. (You're right. In no way is this an alignment problem!)

RADIO WITH A GEIGER COUNTER?

I've got something I'll bet you never heard of before. It's an old portable Sylvania radio, but it also has a built-in Geiger counter! The set is working but I can't get anything out of the counter. There is high voltage on the G/M tube, though.—J. D., Charleston, WV.

You're right, I *have* never heard of this one before. However, I do have a schematic on it (Sams Photofact 345-17). The partial schematic shows how it works.

When switch M7 closes, a pulse of current flows through the transformer. This charges up C8-C9 to a high voltage

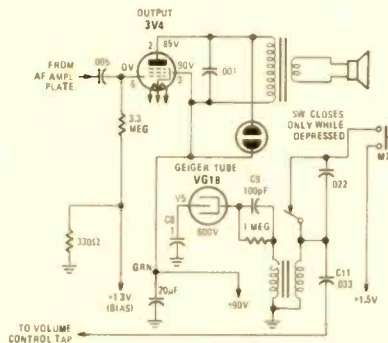

for the counter tube. When the tube fires, the "clock" seems to be coupled back through C11 to the bottom end of the volume-control circuit. The neon lamp may be used as a charge indicator or as a peak limiter to keep excessively high pulses from damaging the output tube.

HORIZONTAL SYNC

I can't stop the picture from sliding sideways in this Admiral 11H chassis. Checking the AFC circuit, tubes (including AFC diodes), etc. didn't help. The hold control can stop the picture momentarily, but when it is stopped a vertical white line appears in the center of the picture. The vertical hold is good. Any help would be appreciated!—J. T., Ocala, FL.

Normally I'd say there's no sync getting to the AFC diodes, but you've got that white line in the picture. You may have some feedback through the B+ line due to a bad filter capacitor. Scope all the

B+ lines for any signals; these cause feedback and all kinds of weird problems.

(Feedback: "Thanks! Capacitor C2A, the 80- μ F section of a multiple filter, was leaky. I replaced it and now it works.")

CATHODE CURRENT RUNS HOT

The 6KM6 horizontal-output tube cathode current in this RCA chassis CTC-27XAD runs 450 mA and there's no output. The grid voltage reads -35, and the screen grid voltage reads +185. I can't get that current down.—H. J., New York, NY.

I can tell you one thing: a +185 voltage on the screen grid is much too high and can cause the cathode current to go way up. Find out why this happens. I have seen sets where the screen-dropping resistor had burned up and dropped in value. The only other thing that could cause the screen voltage to go so high would be an open contact on the screen in the socket. If this is the case, however, the cathode current drops to about 45 or 50 mA! Your drive seems to be normal, but the high screen voltage is not.

MORE BRADFORD FLYBACKS

Like a lot of Service Clinic readers, I also need a Bradford flyback transformer for a 1143B31 chassis and the part number is 334P03402. Can your crystal ball help?—D. B., FPO, NY.

The crystal ball didn't help, but after looking in some catalogs for similar part numbers, I dug up what certainly looks good. At least, the part number is exactly the same—it's a Mitsubishi (MGA). Look up an MGA CH-120 chassis in Sams Photofact 1176. You can probably order one from MGA Melco Sales, Inc., 3030 N. Victoria, Compton, CA 90221.

SLOW WARMUP

This Zenith model 14N28 takes about 1 to 2 minutes to reach full height. The width is OK, but the picture lacks about 3 inches at the bottom of the screen; it then slowly builds up until the screen is full. I've checked out everything I can think of in the vertical circuits, and the waveforms look normal. I tried coolant spray on the circuit; no luck. I'm overlooking something, but don't know what.—J. S., Prospect Heights, IL.

If your picture comes on in-sync and it remains stable, the chances are this is not a problem in the vertical circuitry itself. It is probably something in the supply voltage to it.

There is a small thermistor in the deflection yoke that is supposed to be 1.0-megohm cold and drop to an unknown value. In any case, this thermistor feeds the boost voltage to the plate of the input half of the vertical oscillator. Take the back cover of the deflection yoke off and look for this; it's a small disc-type component. You can replace it with a Workman GM 1-meg thermistor.

R-E

There's only one way to have the newest and most unique top-value electronic products...choose and build from the nearly 400 fascinating kits you'll find in this new

FREE HEATHKIT® CATALOG!



See the world's first Electronic Weather Computer. It indicates, stores and retrieves all temperature, pressure and wind data...even computes wind chill factors for home, farm or office.



See the very finest, most advanced oscilloscope Heath has ever developed. Compare this DC-35 MHz Dual Trace, Delayed Sweep Scope with others costing hundreds of dollars more.



See the new GC-1415 deluxe Digital Car Clock with trip timer and stopwatch. Useful and practical for car, van or truck.

The R/Cers dream — Heath's Pack 17 — 8-channel open gimbal R/C transmitter with instant plug-in frequencies...at big kit savings!



A super coin-shooter! Heath's 'Cointrack' Metal Locator with adjustable discrimination and pushbutton tuning.



See the first and the best electronic digital bathroom scale with a strain-gauge transducer like the most expensive laboratory scales.



See the world's first and finest fully computerized and programmable color TV that lets you program an entire evening's viewing.



See Heath's newest and finest 'rack-mount' series of audio components — professional performance for discriminating audiophiles and music lovers who want the best.

Plus hundreds of top-performing, value-priced electronic kit products for home, hobby or business. See the most powerful personal computer systems you can buy with complete software and peripherals. See the Heathkit Continuing Education Self-Learning Programs in Basic and Advanced Electronics, Automotive Electrical, Test Instruments and Novice and General Amateur Radio Licenses — the most efficient and economical way to stay on top of our electronics world! **FILL-IN COUPON AND SEND TODAY.**

If coupon is missing, write Heath Co., Dept. 020-533 Benton Harbor MI 49022.

Every Heathkit product is backed by world-famous technical service and counsel — plus sales and service facilities at 54 Heathkit Electronic Centers* coast-to-coast (*units of Schlumberger Products Corporation). See the white pages of your phone directory for the center nearest you.

SEND FOR YOUR FREE COPY TODAY!

HEATH Schlumberger	Heath Company, Dept. 020-533 Benton Harbor, Michigan 49022
Please send me my FREE Heathkit Catalog. I am not now receiving your catalogs.	
Name _____	
Address _____	
City _____	State _____
CL-689	Zip _____

**FREE
CATALOG**

new products

More information on new products is available from manufacturers of items identified by a Free Information number. Free Information Card is inside the back cover.

DIGITAL MULTIMETER, model *RMS-350 Volks-meter*, is a battery-operated, 4-digit instrument designed to fit into a tool box. It measures true RMS AC from 1 mV to 750 volts; resistance from 1 ohm to 10 megohms; DC from 1 mV to 1000 volts and AC/DC current from 1 μ A to 1 A.



CIRCLE 143 ON FREE INFORMATION CARD

Features include LCD readout, automatic polarity, overload indication and overload protection, plus a 10-megohm input impedance. The model *RMS-350* measures 1.9 H X 2.7 W X 4-inches D. Optional accessories available include batteries and charger, a probe, carrying case and tiltstand case. Price: \$189.—**Non-Linear Systems, Inc.**, Box N, Del Mar, CA 92014.

CCTV SURVEILLANCE CAMERA, model *ITC-44*, is available with choice of pickup tubes, including vidicon, separate-mesh vidicon, or silicon-target vidicon. With a 3/4-inch vidicon tube, only 1.2 foot-candles are needed from a standard 89% reflectance object; with the silicon-target vidicon tube,



CIRCLE 144 ON FREE INFORMATION CARD

the minimum sensitivity is 0.01 foot-candle. The response range is 1000:1, and it can provide a horizontal resolution of 550 lines (with separate mesh vidicon). With gamma correction off, the S/N ratio is better than 44 dB; the video bandwidth, 6 MHz or better; and the deflection distortion, less than 2%. The model *ITC 44* operates from 117 VAC line; the economy model *ITC-44A* operates from 24 VAC. The unit is housed in an

ABS plastic case, with internal RF shielding, weighs 5 lb., and carries a suggested retail price of \$250.—**Ikegami Electronics (USA) Inc.**, 37 Brook Ave., Maywood, NJ 07607.

WIRE-WRAP TOOL, model *P184-4T1*, uses high abrasion-resistant polyurethane nylon *Tefzel* insulated wire to eliminate measuring. The tool uses the model *P184 Slit-N-Wrap* bit to feed wire from a spool on the shaft. This permits continuous wire-routing in a daisy-chain fashion. The *Slit-N-Wrap* bit can also be used with the model *P184-4T* NiCad-powered pencil-type motor. The *Tefzel* wire is available in 50-foot spools, with red, green, white or yellow insulation. Also available are 120-foot spools of uninsulated copper wire.

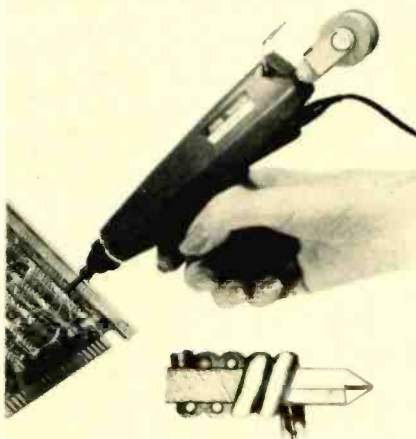

CIRCLE 145 ON FREE INFORMATION CARD

Suggested retail prices: model *P184-4T1*, \$89; model *P184-4T*, \$80; model *P184* bit, \$29.50; *Tefzel*-insulated wire, \$4.18/package of two 50-foot spools.—**Vector Electronic Co., Inc.**, 12460 Gladstone Ave., Sylmar, CA 91342. **R-E**

DIGITAL AUTOMOTIVE INSTRUMENTS, *Indycators* model *DC-17301* clock/timer, model *DC-17304* MPG computer and model *DC-17306*



CIRCLE 146 ON FREE INFORMATION CARD

tachometer, all feature 4-digit fluorescent display, require only 3-wire connection (hardware included). The model *DC-17301* (shown) clock/

timer shows time of day in hours/minutes to 12 hours, or can be used as an elapsed-time counter to read minutes/seconds to 59:59, or hours/minutes to 99:59. Operates on 10-17 VDC and draws only nominal 2 watts. The model *DC-17304* MPG computer displays average miles-per-gallon since first fillup, total miles driven, total gallons purchased and total miles-per-gallon between fillups. Model *DC-1730* tachometer features continuous RPM count, with 1% accuracy full-scale, and automatic memory feature to display preset RPM number. Price: \$39.95.—**Digital Concepts Corp.**, 249 Route 46, Saddle Brook, NJ 07662.

100-WATT REFLECTOR LAMP, model *1300 Dremelite*, can be bench- or table-mounted for do-it-yourself projects and hobbies. Offers 360° rotation angle and a 45-inch arm reach. Addition-



CIRCLE 147 ON FREE INFORMATION CARD

al features include insulator reflector and porcelain socket. The model *1300* is available in white-only, baked enamel finish, and operates from a 100-115-volt, 60-Hz AC source. Options include adjustable clamps and screwdown mounts for additional mounting angles. Suggested retail price, \$39.95.—**Dremel, Div. Emerson Electric Co.**, 4915 21st St., Racine, WI 53406.

SOLDER SPOOL HOLDER, *Solder Mate*, prevents solder wire from unraveling. Portable metal

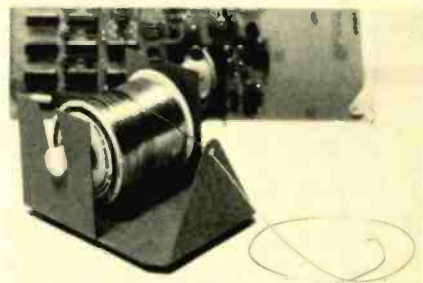

CIRCLE 148 ON FREE INFORMATION CARD

holder permits easy withdrawal of solder; holder is loaded by dropping spool into place and feeding solder through dispenser hole. Suggested retail price, \$4.95.—**Efficiency Products Corp.**, 2 Kennedy Dr., North Chelmsford, MA 01863. **R-E**

stereo products

More information on stereo products is available from manufacturers of items identified by a Free Information number. Free Information Card is inside the back cover.

AM/FM STEREO RECEIVER, model CR-220, provides 15 watts-per-channel RMS into 8 ohms from 20 Hz to 20 kHz, with no more than 0.05% THD. Front-panel controls include power on-off switch, bass and treble switches, variable-loud-



CIRCLE 140 ON FREE INFORMATION CARD

ness switch, tuning switch, and phone jack. Performance specifications for the model CR-220 are: for the amplifier—phono input sensitivity, 2

mV at 1 kHz; phono S/N ratio, 90 dB. For the FM section—alternate channel selectivity, 60 dB; capture ratio, 1.5 dB; 50-dB quieting, 17.3 dBf (mono), 39.2 dBf (stereo); frequency response, 30 Hz–15 kHz +1, -3 dB; S/N ratio, 70 dB (mono), 65 dB (stereo; AM suppression, 52 dB. The AM section provides an alternate channel selectivity of 20 dB and an IHF sensitivity of 18 μ V/m. The model CR-220 measures 435 X 144 X 326.5 mm and weighs 7.6 kg. Suggested retail price: \$220.—Yamaha International Corp., 6600 Orangethorpe Ave., Buena Park, CA 90622.

STEREO COMPONENTS, the model AA-1600 amplifier and the model AD-1701 graphic output indicator, are rack-mountable components. The model AA-1600 delivers 125 watts-per-channel (minimum RMS) into 8 ohms, 20 Hz through 20 kHz, at less than 0.05% THD. Other features include a delay switch, thermal circuit breaker and high-temperature LED indicator. The amplifier can also be installed in optional oak-finish

model AEA-1800-1 case.

The model AD-1701 output indicator has two rows of fifteen LED's for graphic output display, peak-hold circuit and peak/average switch.



CIRCLE 50 ON FREE INFORMATION CARD

Prices: model AA-1600, \$359.95; model AD-1701, \$189.95; model AEA-1800-1, \$27.95.—Heath Co., Dept. 570-070, Benton Harbor, MI 49022. R-E

FREE SWTP

CATALOG

Audio—Computers

Instruments

Kits & Assembled

COMPUTER
PRODUCTS
CATALOGUE



Southwest Technical Products Corporation
219 W. RHAPSODY
SAN ANTONIO, TEXAS 78216

CIRCLE 59 ON FREE INFORMATION CARD

THIS VISE IS CATCHING.

Catch PanaVise. It tilts, turns and rotates your work exactly where you want. Add our new Tray! It catches small parts you drop, separates tools, and keeps parts sorted. The Tray's wide 8 1/4" diameter of cast metal gives 'no-tip' stability, and has 6 slip resistant neoprene feet. Catch all the PanaVise combinations at your distributors now. Write for FREE brochure and distributor list.

PANAVISE®

Dept. CE 11
2850 29th St.
Long Beach, CA 90806

Shown:
315 Circuit Board Holder, # 300 Base, # 312 Tray Base Mount.



CIRCLE 55 ON FREE INFORMATION CARD

String Synthesizers Can Be: Just strings...

....But when
designed by
Marvin Jones
they have:

violins/cello/piano, variable chorusing,
keyboard split, synthesizer interface,
variable sustain controls, jacks for foot
controls, dual violin/cello mixers,
separate mixable piano output, stereo
string & computer interface options.

Stringz 'n' Thingz

just \$295 kit \$600 assembled
from **FAIA** You're gonna love it!

TELL ME MORE

- () Send Assembly & Using Manual \$5 refundable upon purchase Stringz 'n' Thingz.
- () SEND FREE CATALOG

Name: _____

Address: _____

City: _____ State: _____ Zip: _____

FAIA ELECTRONICS Dept. 5-R
1020 W. Wilshire Blvd., Oklahoma City, OK 73116 (405) 843-9626

CIRCLE 21 ON FREE INFORMATION CARD

A Classroom In Your Mailbox!

STUDY
Two-Way Radio

THROUGH THE
REVISED

MTI

Home Study Course

Send coupon below for free course outline
No obligation - No salesman will call

Professional Training in a Unique Career Field

Providing Training to the Industry Since 1960

study FM two-way radio at home!

I am interested in learning more about professional FM two-way radio. Please send me full details on the MTI training program.

Name _____
Address _____
City/State/Zip _____

MTI

Mobile Training Institute

Box 735, Camp Hill, PA 17011-U.S.A.

CIRCLE 39 ON FREE INFORMATION CARD

TIME/VOLTAGE CALIBRATOR

continued from page 39

apply the waveform to a low-pass filter to generate the average DC voltage and then buffer it.

The voltage-calibrator section (Fig. 3) resembles the time section somewhat, but the two circuits are different. Thumbwheel-switch latches IC1-IC4 feed exclusive-NOR inputs. Again, the exclusive-NOR network IC9-IC12 is used as a comparator, but this time it compares the thumbwheel-latch contents to the counter output. When both values agree, the OR-tied output is pulled high by resistor R19. Decade-counters IC17-IC20 are wired as up-counters. For this application, they free-run, starting from 0000, count to 9999, then start over again. Although the clock frequency's accuracy is unimportant in this application, a rather exact 1-MHz signal that is tapped from the 20-MHz timebase count-down section (IC26 pin 14) is used as the volts section's counter clock.

The TTL portion of the volts section must provide a programmable duty-cycle from 0 to 100%, inclusive, in .01 increments (with a 4-decade total). If a flip-flop can be set to 0 when the four decade-counters are at 0000 and then flipped back to 1 when the counter reaches the desired thumbwheel value, this achieves a programmable duty-cycle: the higher the thumbwheel setting the longer the flip-flop stays at 0. Since the counter-clock frequency is 1 MHz, the programmable duty-cycle output has a frequency of 100 Hz.

The duty-cycle flip-flop described above is J-K flip-flop IC39-b. When the counter network reaches 9999, the outputs of counters IC17 and IC20 are low, forcing the output of NOR gate IC38-a high. On the next clock pulse, the counters advance to 0000, and the output of J-K flip-flop IC39-a goes low for one clock cycle. Assuming that the exclusive-NOR comparator output is low at this time (that is, the thumbwheel latches are loaded with a nonzero value), the output of inverter IC38-b is high, forcing the output of IC38-c low. Therefore, inputs J and \bar{K} to IC39-b are high; so on the next clock input, the duty-cycle flip-flop's output, Q, goes low and the counter network increments to 0001. This is the first step of the duty-cycle generation.

The J and \bar{K} inputs of IC39-b are held low and high, respectively, when there is no comparator equal output, or when the counter state is nonzero. This is the hold mode, so the duty-cycle flip-flop maintains its state until there is a change on its inputs.

When the counters and the thumbwheel latches agree in value, the comparator output goes high and the output of inverter IC38-b goes low. The output of IC39-a is high for all counts except .0000, so both the J and \bar{K} inputs to IC39-b are

low. On the next clock cycle, the flip-flop output is set back to a 1 and remains there until the counters again reach 0000, when the cycle repeats.

The counter sequence and the duty-cycle flip-flop's output proceed as follows:

Counter:

9999-0-1-2 ... n-(n + 1) ...
9999-0-1

Duty-Cycle Flip-Flop (IC39-b pin 9)

1-1-0-0 ... 0-1 ... 1-0

Thus, the output stays low for $(n + 1) - 1 = n$ times out of 10,000 counts, so the thumbwheel setting directly loads the correct duty-cycle.

In the event that the thumbwheel latches contain 0000, the outputs of IC38-b and IC39-a go low simultaneously. This forces the output of IC38-c high, which, in turn, forces the output of IC38-d low. Then, IC39-b is constantly loading and then holding a 1 (i.e., the flip-flop output is a DC voltage, with a level corresponding to a 0% duty-cycle, as required).

By using the asynchronous \overline{SET} and \overline{RESET} inputs of flip-flop IC39-b, the duty-cycle logic can be overridden. The \overline{SET} input forces the flip-flop output low (duty-cycle = 100%), and the \overline{RESET} input forces a high output (duty-cycle = 0%). Switch S8 provides the logic signal. When switch S8 is in its center OFF position, the duty-cycle logic performs as described. This switch allows the user to select between the two voltage extremes and any other preloaded value.

The output of the duty-cycle flip-flop is fed to IC37-b, which converts its TTL-compatible voltage swing to a CMOS-compatible voltage. Resistors R24 and R25 limit the maximum voltage input to the CMOS gate to slightly less than 10. The NOR gate IC41 is the CMOS driver. Its V_{DD} supply lead is connected to the output of IC44, the precision voltage reference. Thus, the precision TTL-generated duty-cycle is voltage-level-shifted by parallel-connected NOR gates IC41-b, IC41-c, and IC41-d to produce the time and voltage requirement described earlier in this section.

A low-pass filter consisting of R26-C32, R27-C33 and R28-C34 produces a DC output whose value is equal to the desired voltage setting. The low-pass filter has a time constant of several seconds, so it takes about 10 seconds for the DC-output value to stabilize. Operational amplifier IC42 has a high-impedance JFET input that will not significantly load the low-pass filter's output. It is connected as a voltage-follower, guaranteeing a low-impedance output at PC board locations J and K. Trimmer resistor R34 nulls the op-amp's input-offset voltage and gives the operator a precise 0-volt setting.

Voltage-follower IC43-a has its input connected to the programmable voltage output. Its output, called " V_{HIGH} ", feeds

the V_{DD} lead of CMOS gate IC40 in the time section shown in Fig. 1. Thus, whatever value is loaded in the volts section will be the voltage-high output of the time calibrator's 50% waveform.

A low-output-impedance, ± 20 -mV voltage generator is composed of resistors R29-R32, trimmer R35, capacitors C17 and C31, and voltage-follower IC43-b. The output is used as the ground return for the 10-volt reference IC. Since the precision output is measured with respect to its ground leg, offsetting ground by ± 20 mV (with R35) also offsets the output by an equal amount. If you don't trim the volts-calibrator section, most of this section can be omitted.

Thumbwheel switches S1-S4 (Fig. 4) are coded as BCD-complement, meaning that a 0 is a switch closure and a 1 is a switch open. Pull-up resistors R1-R16 pull any open switch node to 5 volts, but any switch closure will force a ground potential on that node. These two voltage levels are TTL-compatible, therefore they directly drive the latch inputs of the time and volts calibrator.

Three power-supply voltages are needed in the calibrator: +5, +15 and -5 volts. The first voltage powers all the TTL circuitry, and the second two voltages power the analog circuitry in the volts section. Transformer T1 (see Fig. 7) has two secondaries. Secondary 1 is full wave rectified by D1 and D2, filtered by C20 and C21 and regulated down to +5 volts by voltage regulator IC45. A bridge rectifier consisting of D3-D6 at secondary 2 provides both positive and negative voltages, which, in turn, are regulated down to +15 and -5 by IC46 and IC47. Separate secondaries in the power supply help minimize the possibility that the high-frequency voltage and current switching transients in the +5-volt power supply will appear in the analog section of the calibrator's time and volts outputs.

This concludes the theory of operation of the Time/Voltage Calibrator. Next month we will go into construction details and will present the PC board pattern and other pertinent information. **R-E**

AUDIO TEST STATION

continued from page 63

IC701-a is simply an isolator. With S22 in its lower position the timebase frequency is the same as the power-line frequency, which produces one window per second. At the same time pin 8 of IC701 is grounded, which yields an output pulse train of the same frequency as the input signal.

Gate IC701-c, R701 and C702 form the delay circuit. IC701-c provides both isolation and a small amount of delay and R701 and C702 provide additional delay. When S702 is in the one half-second update position, the input signal first arrives at pin 9 of gate A. Pin 8 is still

low, the exclusive OR function is satisfied and pin 10 goes high. A short time later, the signal arrives at pin 8 and pin 10 goes low. Sometime later the input pulse ends. At this time, pin 9 goes low and pin 8 is still high. The exclusive OR is once again satisfied and pin 10 goes high again. A short time later the pulse at pin 8 also ends and pin 10 again goes low. The result is two narrow pulses for each single input pulse. The pulses occur at the beginning and end of the input pulse.

As the input frequency reaches about 300 kHz, the spacing between the two pulses reaches zero and the result is an output pulse the same frequency as the input. This is the only reason for having a one second update at all. That is, to extend the usefulness of the overall counter into this frequency range. If it was only to be used at lower frequencies, the one-second window need never be used.

IC704 is the actual counting element. When the clear input pin is low, IC704 counts the input at pin 36. When the store input pin is low, the number in the counter is transferred continuously to the display. When the clear input is high, the counter is reset. It starts over again at zero when the clear goes low. When the store input goes high, whatever number was last displayed remains displayed until the store goes low again. Since the store input only goes low for a brief period of time at the end of each counting window,

the display shows the number the counter contained at the end of the previous window. Immediately after transferring the number present in the counter at the end of the period, the clear input goes high briefly, which initiates a new period.

The display is multiplexed. That is, only one digit is actually displayed at a time. IC705 provides power to the anode and IC706 provides ground for the cathode. Capacitor C705 establishes the scan frequency. IC704 through IC706 power each digit sequentially in seven segment format. If the LED's were continually powered, each number in the counter would flash sequentially on all six digits simultaneously. IC704 provides the digit scan through IC705. This simply powers each LED display sequentially. Therefore, a particular digit is only powered when the corresponding number from IC706 is to be displayed.

IC705 provides the voltage gain as well as a current gain. This allows IC704 to power the display from the unregulated supply. R705 and R701 provide current limiting for the displays.

Figure 14 shows the location of the Frequency Counter section and Fig. 15 shows the location of the components.

This wraps up the construction phase of the Audio Test Station. Next month we will go into calibration, tests and applications of this valuable addition to your bench. **R-E**

Why buy a multi-capability counter for frequency-only measurements?



The 1911A multicounter makes accurate field transmitter frequency checks easy with the optional battery-pack and whip antenna.

For accurate readings in the presence of noise. Our new 1911/12A multi-counters have both trigger-level and attenuator controls.

For high resolution measurement of low frequency control tones in the period or period-average mode.

For economy. They're priced about the same as many frequency-only models, with totalize, autozero, autoranging, manual and automatic range selection, and more. Standard.

- 1911A for 250 MHz applications: \$495.*
- 1912A for measurements to 520 MHz: \$620.*

Call (800)426-0361, toll free, or write: John Fluke Mfg. Co., P.O. Box 43210, Mountlake Terrace, WA 98043.

*(U.S. price)



1912A 520 MHz model

Fluke Multicounters for Communications Service



2110-8001

CIRCLE 72 ON FREE INFORMATION CARD FOR LITERATURE

CIRCLE 75 ON FREE INFORMATION CARD FOR DEMONSTRATION

Put Professional Knowledge and a
COLLEGE DEGREE
 in your Electronics Career through
HOME STUDY

Earn Your DEGREE

by correspondence, while continuing your present job. No commuting to class. Study at your own pace. Learn from complete and explicit lesson materials, with additional assistance from our home-study instructors. Advance as fast as you wish, but take all the time you need to master each topic.

The Grantham electronics degree program begins with basics, leads first to the A.S.E.T. degree, and then to the B.S.E.T. degree. Our free bulletin gives complete details of the program itself, the degrees awarded, the requirements for each degree, and how to enroll. (We are located at 2500 S. LaCienega Bl., Los Angeles, Calif.) Write to our mailing address shown below for Bulletin R-79.

Grantham College of Engineering
 P. O. Box 35499
 Los Angeles, California 90035

Worldwide Career Training thru Home Study
 CIRCLE 31 ON FREE INFORMATION CARD

FREE
 - GROUP SUPPLIES

NATCAM catalog
 Shopping center for small and precision tools

A fine selection of small tools, measuring instruments, hard-to-find items for shop, home and lab. Convenient one-stop shopping for technicians, engineers, craftsmen, hobbyists. Major credit cards accepted, satisfaction assured. Get your NATCAM catalog today.

National Camera, Inc.
 2000 West Union Ave., Dept. GBF
 Englewood CO 80110 USA

BOWLING GAME
 continued from page 43

by one as they are attached to their respective resistors, R20-R29. Use a 6-volt supply with a 220-ohm resistor in series (or a 1.5-volt battery with a 100-ohm resistor) to individually light the LED's for identification. Attach the 22-gauge anode lead to the positive power supply. The RESET pushbutton, S2, connects to point "R" on IC's 1-4 and to the V+ line.

It is prudent to test the gating circuits before hooking up the photo-Darlington transistors. Apply power to the circuit

and use test leads to connect each of the inputs to either ground or V+. Use a voltmeter or logic probe to follow each signal through the gates and into the diode matrix. If an error has been made, it can be traced and corrected in a matter of a few minutes. Try all the combinations shown in Table 1, checking each for the proper output.

Now, connect the photo-transistor leads to their appropriate points on IC's 1-4, apply a light source and selectively block each of the slots to make sure the voltage swing from light to dark is sufficient to trigger the CMOS latches. In general, the dark voltage at the junction

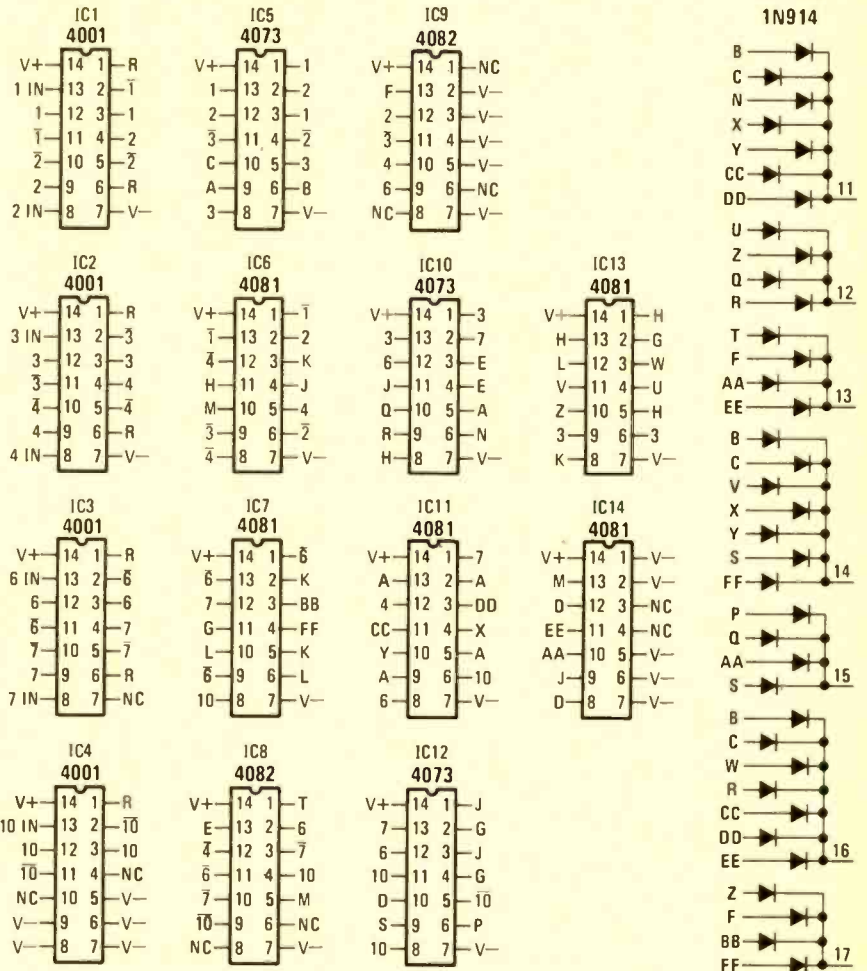

NOTE: IC'S ARE SHOWN AS MOUNTED WITH PINS FACING UP. (SEE TEXT)

FIG. 8—WIRING GUIDE for the point-to-point connections between the IC's and the diode gates.

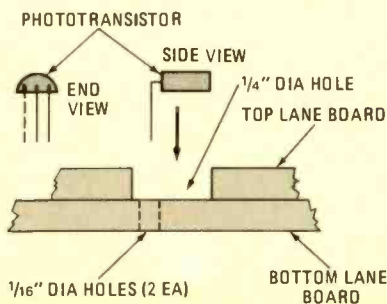

FIG. 9—HOW PHOTOTRANSISTORS are mounted. Be careful when bending pins.

of the collector, the resistor and the gate must be greater than 0.7 times the V+ voltage, and the lighted voltage should be less than 0.3 times the V+ voltage. If these voltages are too low, try decreasing the value of the pullup resistor. If they are too high, increase the value. If this doesn't work, replace the transistor. In tests of over 40 junk-box photo-Darlington transistors, 32 were usable with a pullup resistor value near 15K and with a 40-watt incandescent lamp 48 inches away. Normal room lighting is usually well above this level.

market center

CLASSIFIED COMMERCIAL RATE (for firms or individuals offering commercial products or services) **\$1.50 per word** (no charge for zip code) . . . minimum 15 words.

NONCOMMERCIAL RATE (for individuals who want to buy or sell personal items) **85c per word** . . . no minimum.

ONLY FIRST WORD AND NAME set in bold caps. Additional bold face (not available as all caps) at 10c per word. Payment must accompany all ads except those placed by accredited advertising agencies. 5% discount for 6 issues, 10% for 12 issues within one year, if paid in advance. All copy subject to publisher's approval. Advertisements using P.O. Box address will not be accepted until advertiser supplies publisher with permanent address and phone number. Copy to be in our hands on the 26th of the third month preceding the date of the issue (i.e., August issue closes May 26). When normal closing date falls on Saturday, Sunday, or a holiday, issue closes on preceding working day.

FOR SALE

FREE catalog (anglais). IC's, semi's. **CORONET ELECTRONICS**, 649A Notre Dame W., Montreal, Que., Canada, H3C 1H8. US inquiries.

RADIO & TV tubes 36c each. One year guaranteed. Plus many unusual electronic bargains. Free catalog. **CORNELL**, 4217-E University, San Diego, Calif. 92105

TEST equipment catalog listing used Tektronix, HP and GR equipment at bargain prices. Price \$1.00 refundable with first order. **PTI**, Box 8699, White Bear Lake, MN 55110

NAME brand test equipment. Guaranteed discounts up to 50%. Free catalog. **SALEN ELECTRONICS**, Box 82-M, Skokie, IL 60077

FREE catalog of new merchandise, at great prices. IC's, semi's and more. **KEY ELECTRONICS**, Box 3506-RE, Schenectady, NY 12303

VIDEO tape recorders, Shibaden SV-700-UC. New in factory cartons. \$400.00 FOB Loveland. Write for details. **LOVELAND ENGINEERING ELECTRONICS**, 6651 Epworth Road, Loveland, OH 45140

SELLING Rider's Radio 1-15, eleven volumes, \$175. Also 27 television volumes, \$295. Early Sams' Photofacts. **BEITMAN**, Box 46, Highland Park, IL 60035

COMPUTER memory. contains 72 2107B's in sockets \$72. **GEORGE MURPHY**, RD 1, Fort Plain, NY 13339

GIANT screen TV! Same components as \$2000-\$4000 sets. Plans, three-element lens, and washable screen, \$329. Plans only, \$5 (deductible from order). **VIDEO PROJECTION**, P.O. Box 158, Lake Zurich, IL 60047

INVENTORS

FREE information on offering your invention for sale. **KESSLER SALES CORPORATION**, C-315, Fremont, OH 43420

BUSINESS OPPORTUNITIES

MECHANICALLY inclined individuals desiring ownership of Small Electronics Manufacturing Business—without investment. Write: **BUSINESSES**, 92-R, Brighton 11th, Brooklyn, NY 11235

To run your own classified ad, put one word on each of the lines below and send this form along with your check for \$1.50 per word (minimum 15 words) to:

Radio-Electronics, 200 Park Avenue South, N.Y., N.Y. 10003

ORDER FORM

PLEASE INDICATE in which category of classified advertising you wish your ad to appear. For special headings, there is a surcharge of \$10.

() Plans/Kits () Business Opportunities () For Sale
() Education/Instruction () Wanted ()

Special Category: \$10

(PLEASE PRINT EACH WORD SEPARATELY, IN BLOCK LETTERS.)

1	2	3	4	5
6	7	8	9	10
11	12	13	14	15
16	17	18	19	20
21	22	23	24	25
26	27	28	29	30
31	32	33	34	35

Burglar • Fire • Smoke Alarm Catalog

• Billions of dollars lost annually due to lack of protective warning alarms.

FREE CATALOG Shows you how to protect your home, business and person. Wholesale prices. Do-it-yourself. Free engineering service.



Burdex Security Co.

Box 82802 RE-059 Lincoln, Ne. 68501

PICTURE TUBE MACHINE

We buy and sell NEW and USED CRT rebuilding machinery. COMPLETE TRAINING. Buy with CONFIDENCE from the ORIGINAL MFR.

For complete details send name, address, zip to:

LAKESIDE INDUSTRIES
4071 N. Elston Avenue
Chicago, Ill. 60618
Phone: 312-583-6565



MECHANICALLY INCLINED INDIVIDUALS

Assemble electronic devices in your home. Be your own boss. Get started in spare time. Experience, Little Knowledge or Investment Necessary. Expect big profits: \$300 - \$600/Wk. Possible. Write for free literature telling how.

ELECTRONIC DEVELOPMENT LAB
Box 1560R, Pinellas Park, FL 33565

AMAZING ELECTRONIC PROJECTS and PRODUCTS:

Lasers Super Powered, Burning, Cutting, Rifle, Pistol. Pocket. See in Dark—Shotgun Directional Mike—Unscramblers—Giant Tesla—Stunwand—TV Disruptor—Energy Producing, Surveillance, Detection, Electrifying, Ultrasonic, CB, Auto and Mech. Devices, Hundreds More—All New Plus INFO UNLTD PARTS SERVICE Catalog \$1. Information Unlimited, Dept. R8 Box 716 Amherst, N.H. 03031.

YOUR PHONE CALLS ON TAPE

Record incoming and outgoing calls automatically with this all solid state unit connected to your telephone jack and tape recorder. Starts recording when phone is lifted. Stops when you hang up, making a permanent record. Easily installed. No extra monthly phone charges. FCC APPROVED
2-1/4 x 1-3/4 x 3/4 **\$24.50***



VOX VOICE ACTIVATED CONTROL SWITCH

2-1/4 x 3/4 x 1-1/2
Self contained solid state. Excellent adjustable sensitivity. Recorder activated by voices or other sounds. Uses recorder mike or remote mike. Great for home, business, etc. **\$24.95***



FCC APPROVED AMAZING ELECTRONIC MICRO MINI MIKE

Among world's smallest, solid state, self contained WIRELESS MIKE. Mercury Bat. furn. Picks up most sounds and transmits without wires up to 300 ft. thru FM Radio Tuneable. Use as mike, ampl., alarm & alert system, baby sitter, hot line, etc. (*Plus \$1.00 Post. & Hdlg.) Money back guarantee. California residents add tax. Free data, Mail order. Visa, M/C, Cod's o.k. Quantity discount available. AMC Sales, Dept. 19, 9335 Lubec St., Box 928, Downey, Calif. 90241 Phone (213) 869-8519



\$18.95*
2-1/4 x 3/4 x 1/2"

SPEAKER INFORMATION KIT

Get 70 pages of speaker facts, specs, construction tips plus info on our raw speakers, crossovers and a line of 9 quality hi-fi speaker system kits. We'll send you our full-color catalog; plus **How to Hook Up Your System**, an exhaustive step-by-step treatise on hi-fi system installation; and our **Speaker Operating Manual**, chock full of facts on how to get the most from any speaker system. For Free. Even if you don't buy from us we want you to have the facts. That's how we got to be the world's largest manufacturer of speaker kits.

Send to:
Speakerlab, Dept. 5-RE
 735 N. Northlake
 Seattle, WA 98103



Big CATALOG

Write for Your Free Copy

7808 N. 27th Avenue
 Phoenix, Arizona 85021
 (602) 995-9362



TRI-TEK
 incorporated

PRINTED CIRCUIT

Positive Acting Photo Resist; Carbide bits; Bubble etchers; Artwork; Epoxy Glass Boards.

Send stamp & address label for flyer
TRUMBULL
 833 Balra Dr., El Cerrito, CA 94530

PLANS & KITS

LINEAR AMPLIFIER: Ham only 2-30 MHz, 100 watt, solid-state. **FREQUENCY COUNTER:** 300 MHz, miniportable/mobile, memory! **VOX-COMPRESSOR:** Splatter-free modulation booster. Construction plans \$3.00 each. All \$7.50! Many others, catalog with order. **PANAXIS PRODUCTIONS**, Box 130-F5, Paradise, CA 95969

SCANNER users—build many useful accessories. Free kit catalog. **CAPRI ELECTRONICS**, Route 1R, Canon, GA 30520

SAVE 50%. Build your own speaker system. Write for catalog: **McGEE RADIO**, 1901 McGee, Kansas City, MO 64108

CONSTRUCTION plans for profitable business ideas. Catalog \$1.00. **GARLING**, 438 N. Garfield Street, Lombard, IL 60148

PRINTED circuit boards from your sketch or artwork. Affordable prices. Also fun kit projects. Free details. **DANOCINTHS INC.**, Box 261, Westland, MI 48185

PROJECTION TV... Convert your TV to project 7 foot picture. Results equal to \$2,500 projector. Total cost less than \$20.00. Plans & lens \$16.00. Illustrated information free. **MACROMG E**, Washington Crossing, PA 18977

LASER diode plans: \$2.00 one to forty-watts output (specify). **SCOTT**, 12320 SW Spring Court, Portland, OR 97225

EDUCATION & INSTRUCTION

TELEPHONE bugged? Don't be Watergated! Countermeasures brochure \$1.00. **NEGEYE LABORATORIES**, Box 547-RE, Pennsboro, WV 26415

UNIVERSITY degrees by mail Bachelors, Masters, Ph'D's... Free revealing details. **COUNSELLING**, Box 317-RE5, Tustin, CA 92680

ASTONISH your friends with magic, E.S.P., card tricks you can do. Details: **LANGEN**, Box 191-CA, Downsview, ONT, M3M 3A3

FCC EXAM-QUESTIONS. First/second license \$8.95. Third/broadcast endorsement \$4.50. Revised guide guaranteed. Postpaid. **PANAXIS**, Box 130-F5X, Paradise, CA 95969

PASS FCC EXAMS

The Original FCC Tests Answers exam manual that prepares you at home for FCC First and Second class Radiotelephone licenses. Newly revised multiple choice exams cover all areas tested on the actual FCC exam. Plus "Self-Study" Ability Test. Proven! \$9.95 postpaid. Moneyback Guarantee.

COMMAND PRODUCTIONS P.O. Box 26348 E
 Radio Engineering Division San Francisco, CA 94126

HIGHLY PROFITABLE ONE-MAN ELECTRONIC FACTORY

Investment unnecessary, knowledge not required, sales handled by professionals. Ideal home business. Write today for facts! Postcard will do. **Barta-RE-Q**, Box 248, Walnut Creek, CA 94597.

FREE KIT Catalog

AUTORANGE DIGITAL CAP-METER KIT. Still the best for only \$74.95 contains TEST & EXPERIMENTER'S EQUIP.
 Phone 415-447-3433
 Write or Phone for FREE CATALOG.
 Average 1 minute Saturday call is 21¢.

DAGE SCIENTIFIC INSTRUMENTS
 BOX 1054R LIVERMORE CA 94550

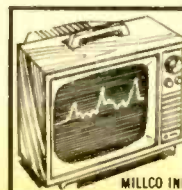

BIG SCREEN OSCILLOSCOPE
 Converted from ANY Size TV Set...
 Hams, Technicians, Hobbyists, Broadcasters...
 Minor, inexpensive changes convert TV set to super sensitive testing device. No electronic experience needed. Follow clear cut plans. Fully illustrated. Use in workshop, lab, school, etc.
 Any size screen Any size TV set...
 Complete Set of Plans \$4 (INCL 50¢ FOR POST & HANDLING)
MILCO IND., DEPT. DP-03 BOX 91, KOSSE, TX 76653

Featured in April RADIO ELECTRONICS

DELTA Burglar ALARM

W-H-O-O-P!!
 W-H-O-O-P!!
\$24.50
MOTION DETECTOR

DELTA MOTION DETECTOR. This device detects any motion or movement for a minimum distance of 8-ft. The secret is in the ultra-compact custom LSI chip, which combines the latest in linear & digital circuitry. The device is completely self-contained, in a case 6 x 3 x 2 1/2", and operates from four "AA" NiCad batteries. Nothing else is needed, for the device to perform its basic function, motion detection. When motion or movement is detected, a "whoop" alarm is sounded. The **MOTION DETECTOR** is designed to provide either an audible or silent alarm. The silent alarm is controlled by a timer, which delays the alarm up to 30 seconds. The silent alarm activates a relay, whose contacts are brought out to plug, and will activate ANY device, such as siren, horn, tape recorder, telephone dialer, etc.

The Motion Detector works on a CHANGE OF LIGHT. Any change of 5% or more, triggers the detector. Works within a range of 0.1 candlepower (almost dark), to 100 candlepower (quite bright), a range of 1000 to 1. NO external light source is needed.

When left in a darkened or semi-darkened room, the Motion Detector acts as a fantastic PIR ALARM. The light from a single match, anywhere in the room, triggers the alarm, as the device becomes an intrusion alarm and fire alarm, all in one.

Delta No.	Description	Sale
5611R	Complete motion detector kit (less batteries)	\$24.50
1072R	Motion Detector Chip only, with data	8.95
5611R	P.C. boards, set of 2	6.50
5288R	"AA" NiCad Batteries, set of 4	4.50
5635R	Battery charger for above	5.95
5635R	Completely assembled kit, w/batteries & charger	69.50

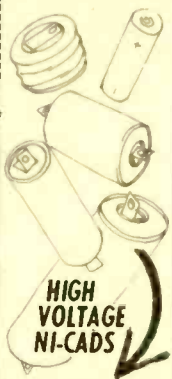

HIGH VOLTAGE—HIGH CAPACITANCE
Laser & Photo Flash Capacitors
\$20.95 EACH
 2 for \$40.

HIGH VOLTAGE NI-CADS
 *Have tabs to permit soldering.

Delta No.	Type	Ampere Hours	Dimen.	SALE
5699R	2.5V	200m	.667 dia. x 1.442	2.78
5701R	3.75V	200m	.665 dia. x 2.06	2.88
5695R	3.9V	235m	.669 dia. x 2.110	2.88
5702R*	4.0V	250	1.375 dia. x .825	3.08
5698R*	6.0V	500m	1.420 dia. x 2.213	3.98
5700R*	12.0V	.180	1.054 dia. x 3.218	4.58
5697R*	14.4V	.500	1.430 dia. x 4.874	4.98
5696R*	28.8V	.250	1.535 dia. x 5.550	12.88

RECHARGEABLE—100% GUARANTEED

These capacitors are 40 Mfd @ 300V & are basically for laser & hi-speed photography, but may be used wherever high voltage, high capacity is needed. These capacitors are oil-filled & high capacity is needed. These capacitors are oil-filled & high capacity is needed. They are removed from eqpt. Completely tested & guaranteed. They are made by several companies, SPRAGUE, CORNELL DUBILIER, etc. Wt. 10 lbs. Size 3 1/4" x 4 1/2" x 9 1/2". No. 2738R

Miniature Digital Electronic Counter

BankAmericard **Master Charge**
NO. 5709R
NO. 5708R
YOUR CHOICE
\$3.95
 TWO for \$7

We have acquired 2 models of a digital counter which was designed to help people slow down eating. Here's how it works when you take a bite, you push the button... a "1" appears... then 25 visible pulses, in which time you are supposed to chew with each pulse. At the end of this cycle, the button is pushed again, and... the number "2" appears... again, followed by the 25 pulses. Since this is a 2-digit readout, 99 mouthfuls can be counted. There is a control to speed up or slow down the pulses in the truly unique digital counter with 7-segment LED readouts. Of course, this device may be adapted to your own use... limited only by one's imagination.

Operates from a 9V transistor battery. Each model does the same thing, but the 2 devices are slightly different in size & construction. No. 5709 uses 4 discrete CMOS chips & is 2 1/4" L x 1 1/4" W. No. 5708 uses a special integrated Semiconductor chip MM56107N and is 1 3/4" L x 1 1/4" W. Both devices have a push button, an on-off switch, 2 digit HP or NS display & a 9V battery clip. Brand new & guaranteed.

Pre Programmed PARTS

PRE-PROGRAMMED components mounted on reels for use in automatic inserting eqpt. These strips consist of a variety of components such as resistors, capacitors, diodes, zeners, etc. Fortunately we have acquired several 100-lb. all mounted on reels with full leads. Upon examination of these strips we noted there were tantalum capacitors, mostly 5% resistors and many zeners.

A sample 1/4 lb. had the following: 216 1/4-watt 5% resistors, 18 1/2-watt 5% resistors, 28 small signal diodes and 30 tantalum capacitors. Not every 1/4 lb. assortment is the same, but the one we chose is average. We guarantee a minimum of 250 components with most lots running over 300 for a 1/4-lb. assortment.

Would You Believe 250-300 (or 14 lb.) of Assorted Parts For Only... **\$3**

Delta No. 6600R-1/4	1/4 lb.	\$ 3.00
Delta No. 6600R-1/2	1/2 lb.	\$ 5.50
Delta No. 6600R-1	1 lb.	\$10.00

ALCOSWITCH

Double-Pole Baton Toggle Switches
 Each **48¢**
Bank of 5 Alcoswitches
\$1.99 Each Set Of FIVE
 FIVE CST-022N switches mounted on a PC board, easily removed by desoldering. Cost to you is less than 40¢ each.

NEW MAIL-ORDER ADDRESS:

FREE DELTA ELECTRONICS
120-PG. 'SURPLUS' CATALOG
 176 SECOND AVE.
 WALTHAM, MASS.
 02154
TEL. (617) 388-4705

When in our area, northeastern Mass. or southern N.H. visit our retail at 7 Oakland St., Amesbury, Mass.

RADIO-ELECTRONICS

BK PRECISION OSCILLOSCOPES

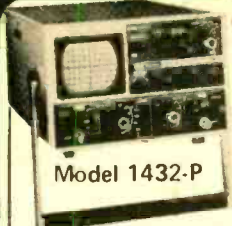

Model 1432-P

New 15MHz portable 3" dual-trace scope

- 15MHz bandwidth with smooth roll-off, usable response extends beyond 30MHz
- 2mV/div. vertical sensitivity • Operates on 117VAC, 234 VAC, 12VDC or optional internal battery pack • Fully regulated high- and low-voltage supplies



1472C-P

Dual-Trace 5" -15MHz Triggered Sweep

- 24nSEC rise time permits display of high-speed square wave pulses • Dual trace display
- Individual vertical sensitivity and positioning controls • Large 8 x 10cm viewing area

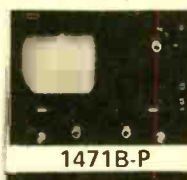

1471B-P

Dual-Trace 5" -10MHz Triggered Sweep

- Usable deflection to 15MHz • 35nSEC rise time permits accurate display of high-speed square wave pulses • Large 8 x 10cm rectangular viewing area • Front panel Vectorscope operation with matched sensitivity inputs • TTL compatible intensity modulation (Z-axis) input



1403A-P

3" -5MHz Solid State Oscilloscope

- High sensitivity • CB modulation monitor
- Ultra compact and lightweight (weighs only 8 1/2 lbs.) goes anywhere • Vertical sensitivity 10mV/division • New high brightness CRT and smoked-glass graticule

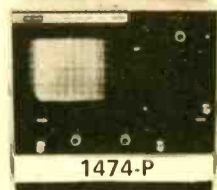

1474-P

Dual-Trace 5" -30MHz Triggered Scope

- 11.7 nS rise time • 30 MHz dual trace operation • Internal signal delay line • 21 position sweep switch

TV Test Equipment

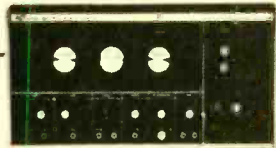

Television Analyst Model 1077B

- Cuts troubleshooting time in half • Provides signal substitution for the entire range of signals present in any TV set, black-and-white or color • Horizontal and vertical drive for solid state and tube type circuits
- Audio output • Built-in scanner for test-pattern slides (supplied) or any 3 x 4" positive transparency
- High-voltage indicator • 8 VHF channels... all UHF channels 14-83

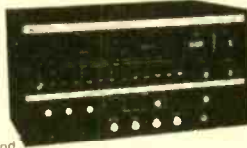

Solid State Sweep/Marker Generator

- Four instruments in one: sweep generator; marker generator; marker adder; bias supply • Complete accessory pack • All interchanging changes and generator selections accomplished internally with master function switch and front panel controls • Concentrates all TV alignment tools (except oscilloscope and VTVM) into one, easy-to-use instrument.

Model 415

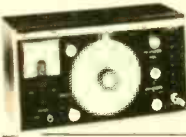

Solid-State RF Signal Generators

- 100 kHz to 216 MHz in 5 bands • Six individually shielded step attenuators plus variable fine output level control with calibrated meter provide widest range of outputs with known signal levels • Double shielding eliminates spurious radiation even at outputs of 1 μ V • Internal crystal calibrator has accuracy of better than 0.1%

Model E 200D



Model 467

CRT Restorer/Analyzer

- Test and restore CRT's faster with fewer callbacks • Exclusive multiplex technique tests all three guns of color CRT simultaneously under actual operating conditions even CRT's with common G1 and G2

Digital IC Color Generator/Analyst



Model 1248

- Generates 9 patterns and logic functions
- Locate dead IF stages • Check operation of mixer RF and local oscillators • Check stages sequentially
- Locate color shifts and internal ghosts from RF mixer, IF or video stages. Plus all standard color generator uses
- Switchable horizontal and vertical sync output

Before you buy, check our prices...

FORDHAM

Call TOLL FREE (800) 645-9518
In N.Y. State call (516) 752-0050

YOUR ONE STOP DISCOUNT CENTER

Master Charge, Bank Americard, Visa, C.O.D.'s accepted. FREE Send for new 1978 catalog of over 3,000 items 164 pages of test equipment, CB tools, tubes, components and electronic supplies

RADIO SUPPLY CO. INC.
855R Conklin St.
Farmingdale, N.Y. 11735

ADD \$3.00 TO COVER SHIPPING, HANDLING & INSURANCE IN N.Y. Res. add approx sales tax.

3 1/2 Digit Mini-Multimeter Model LX 303

- 100 mV DC F.S. Sensitivity
- 19 Ranges and Functions
- 200 Hours 9V Battery Life
- Auto Zero, Polarity, Overrange Indication

Reg \$74.95 **\$67.50** **HICKOK**

SENCORE TV-VTR-MATV and Video Analyzer

Model VA48

Reg \$875.00 **\$975.00**

CONTINENTAL SPECIALTIES

100 MHz 8-Digit Counter \$119.00 Model MAX-100

- 20 Hz-100 MHz Range • 8 LED Display • Fully Automatic
- Includes full PCB manual

Now Available **PS500 500MHZ Prescaler \$52.95**

BK PRECISION 3 1/2-Digit Portable DMM

- Overhead Protected • Battery or AC operation • 3" high LED Display
- Auto Zeroing

Model 2800

comes complete with test leads, operating manual and spare fuses

Model 2810 **\$110.50**

Ungar Heat Gun

Model 2800

Reg \$65.00 **\$46.50**

Weller Xcelite

Model 99PR

Reg \$269.95 **\$15.95**

BK PRECISION Digital Capacitance Meter

Model 1500

Reg \$249.95 **\$110.50**

CODE-A-PHONE Telephone Answering Devices

Model 1400 \$199.95

BSR Changer Accessories

Model BSR 12V

Reg \$24.95

WAHL NEW ISO-TIP "Quick Charge"

Model 7800

Reg \$27.95

6" x 9" 3-Way Speaker

Model 7800

Reg \$14.95

NLS 15 MHz Mini Oscilloscope Model MS 15

Reg \$318.00 **\$269.95**

- Battery or line operation
- Automatic and line sync modes
- Power consumption less than 15 W

NDW AVAILABLE

Dual Trace Version Model MS 215 Reg. \$435.00 **\$369.95**

Service Master Attache Style Tool Kit Model 995M

Reg \$42.95

Tool Cases Model TC 100/ST Reg. \$283.00 **\$269.95**

Roll Kit Model 99PR Reg. \$15.95

Logic Monitor Model LM-1

Reg \$52.95 complete

- Automatically displays static and dynamic logic
- Works with DTL, TTL, TTL and CMOS • 16 LED display
- Circuit powered design

HICKOK Function Generator Model 270

Reg \$169.15

BK PRECISION 15MHz Trace Scope Model 1432P

Reg \$780.00 **\$663.** with probes

SENCORE Logic Probe Model LP-1

Reg \$40.00

- Compact circuit powered
- Detects pulses as short as 50 nSec
- Multi-family compatibility: DTL, TTL, HTL, CMOS

LEADER Instruments Corp 20 MHz. Dual Trace Model L80 508

Reg \$769.95 **\$654.50** with accessories

- Add, subtract modes on CH 1 & CH 2
- Front panel X-Y operation
- 17.5 nSEC rise time

platt Attach Tool Case with 2 Removable Pallets Model 600T

Reg \$89.00 **\$65.00**

HICKOK Substitution Box Model 2910

Reg \$51

Weller Controlled Output Soldering Station

Reg \$45.00 **\$45.00** Model WTCP-N

FREE 1979 Catalog

SENCORE POCKET CRICKET TRANSISTOR/FET TESTER Model MG 10A

Reg \$175.00 **\$99.95** TF 40

Auto Stereo 40 Watt Power Booster POW-40 Reg. \$39.95 **\$24.95**

Magnifier LAMP Model MG 10A

Reg \$49.50

700 Series Precision ground and polished magnification lens. Uses 22W T-9 Cutoff Fluorescent

30MHz Portable Frequency Counter Reg. \$120.00 **\$59.95**

Transistor Tester Model 100

Reg \$22.00

- 3 volt battery included
- Movable base pin (conforms to TO 5, TO 18 and small in-line types)

In-Dash AM/FM 8 Track Stereo C-777

Reg \$52.50

AM/FM Cassette Stereo CAS 888

Reg \$57.50

Call TOLL FREE (800) 645-9518
For N.Y. State call (516) 752-0050

Master Charge • Bank Americard • EOD • Check • Money Order • C.O.D. • Extra New York State residents add approx sales tax.

FORDHAM
855R Conklin St. Farmingdale, N.Y. 11735

AVAILABLE NOW!

ONLY \$3.95
Add \$1.00 for shipping

JAPANESE TRANSISTOR SUBSTITUTION MANUAL



An invaluable Japanese to Japanese substitution guide for approximately 3000 transistors

- Covers the 2SA 2SD 2SK and 2SD series
- Introduction includes a guide to understanding Japanese transistors
- A 90 page 8 1/2 by 11 soft cover book

PARTS PROCUREMENT PROBLEMS

FUJI-SVEA Has the Largest Inventory of Original Japanese Parts Anywhere

Seeking Original Japanese Replacement Parts for CB, TV and Stereo Repair Use?

TYPE	25-UP	10-24	1-9	TYPE	25-UP	10-24	1-9	TYPE	25-UP	10-24	1-9	TYPE	25-UP	10-24	1-9
2SA 473	45	55	60	2SB 346	30	35	40	2SC 693F	20	27	30	2SD 234	60	70	80
2SA 483	2.00	2.20	2.50	2SB 367	1.10	1.25	1.40	2SC 696	1.00	1.20	1.30	2SD 235	60	70	80
2SA 484	1.50	1.75	1.95	2SB 368B	1.80	2.00	2.25	2SC 708	1.30	1.45	1.60	2SD 261	35	40	45
2SA 485	1.40	1.60	1.80	2SB 379	70	80	90	2SC 710	20	27	30	2SD 279	50	55	60
2SA 489	1.10	1.25	1.40	2SB 381	30	35	40	2SC 711	20	27	30	2SC 1306	1.30	1.45	1.60
2SA 490	70	80	90	2SB 400	30	35	40	2SC 712	20	27	30	2SC 1307	1.90	2.10	2.40
2SA 493	45	53	59	2SB 405	30	35	40	2SC 715	30	35	40	2SC 1312	20	27	30
2SA 495	30	35	40	2SB 407	80	90	100	2SC 717	35	40	45	2SC 1313G	20	27	30
2SA 496	50	64	70	2SB 415	30	35	40	2SC 727	1.00	1.20	1.30	2SC 1316	4.20	4.40	4.90
2SA 497	1.00	1.20	1.30	2SB 434	80	90	100	2SC 730	3.00	3.20	3.40	2SC 1317	20	27	30
2SA 505	50	64	70	2SB 435	90	110	1.20	2SC 731	2.50	2.70	2.90	2SC 1318	35	40	45
2SA 509	30	35	40	2SB 440	40	53	59	2SC 732	20	27	30	2SC 1325A	6.50	6.90	7.60
2SA 525	50	64	70	2SB 449	1.30	1.45	1.60	2SC 733	20	27	30	2SC 1327	20	27	30
2SA 530	1.50	1.70	1.90	2SB 461	90	110	1.20	2SC 734	20	27	30	2SC 1330	50	55	60
2SA 537A	1.50	1.70	1.90	2SB 463	90	110	1.20	2SC 735	20	27	30	2SC 1335	50	55	60
2SA 539	40	45	50	2SB 471	1.10	1.25	1.40	2SC 738	20	27	30	2SC 1342	45	53	59
2SA 545	45	53	59	2SB 472	2.10	2.50	2.80	2SC 756	1.50	1.80	2.00	2SC 1344	45	53	59
2SA 561	30	35	40	2SB 473	80	90	100	2SC 756A	1.50	1.80	2.00	2SC 1358	4.20	4.40	4.90
2SA 562	30	35	40	2SB 474	70	80	90	2SC 763	35	40	45	2SC 1359	30	35	40
2SA 564A	20	27	30	2SB 481	90	110	1.20	2SC 773	35	40	45	2SC 1360	50	55	60
2SA 565	70	80	90	2SB 492	60	70	80	2SC 774	1.00	1.20	1.30	2SC 1362	35	40	45
2SA 566	2.50	2.70	3.00	2SB 507	80	90	100	2SC 775	1.40	1.60	1.80	2SC 1364	35	40	45
2SA 606	1.00	1.20	1.30	2SB 509	1.10	1.20	1.30	2SC 776	2.00	2.20	2.50	2SC 1377	3.20	3.40	3.70
2SA 607	1.10	1.25	1.40	2SB 511	70	80	90	2SC 777	3.00	3.25	3.50	2SC 1383	30	35	40
2SA 624	70	80	90	2SB 514	70	80	90	2SC 778	2.90	3.20	3.40	2SC 1384	40	45	45
2SA 627	3.10	3.30	3.60	2SB 523	70	80	90	2SC 781	1.90	2.00	2.10	2SC 1396	45	53	59
2SA 628	30	35	40	2SB 526C	70	80	90	2SC 783	2.10	2.50	2.80	2SC 1398	70	80	90
2SA 634	40	45	50	2SB 527	90	110	1.20	2SC 784	30	35	40	2SC 1400	35	40	45
2SA 640	30	35	40	2SB 528D	70	80	90	2SC 785	35	40	45	2SC 1402	3.00	3.20	3.40
2SA 642	30	35	40	2SB 529	70	80	90	2SC 789	80	90	100	2SC 1403	3.20	3.40	3.70
2SA 643	30	40	45	2SB 530	3.20	3.40	3.70	2SC 790	80	90	100	2SC 1407	50	55	60
2SA 653	1.90	2.10	2.40	2SB 531	1.80	2.00	2.25	2SC 792	2.00	2.20	2.50	2SC 1419	60	70	80
2SA 659	35	40	45	2SB 536	1.00	1.20	1.30	2SC 799	2.00	2.20	2.50	2SC 1444	1.60	1.80	2.00
2SA 664	60	64	70	2SB 537	1.00	1.20	1.30	2SC 828	20	27	30	2SC 1445	2.50	2.70	2.90
2SA 666	3.65	3.80	4.20	2SB 539	3.20	3.40	3.70	2SC 829	20	27	30	2SC 1447	60	70	80
2SA 671	80	90	100	2SB 541	3.20	3.40	3.70	2SC 830H	2.50	2.70	3.00	2SC 1448	70	80	90
2SA 672	30	35	40	2SB 554	5.00	6.00	6.60	2SC 838	35	40	45	2SC 1449	60	70	80
2SA 673	35	40	45	2SB 557	2.10	2.50	2.80	2SC 839	30	35	40	2SC 1451	1.00	1.10	1.20
2SA 678	35	40	45	2SB 561B	35	40	45	2SC 853	70	80	90	2SC 1454	3.20	3.40	3.70
2SA 679	4.20	4.40	4.90	2SB 564	40	53	59	2SC 867	3.20	3.40	3.70	2SC 1475	80	90	100
2SA 680	4.20	4.40	4.90	2SB 595	1.10	1.40	1.50	2SC 867A	3.20	3.40	3.70	2SC 1478	50	55	60
2SA 682	80	90	100	2SB 596	1.10	1.40	1.50	2SC 870	35	40	45	2SC 1509	80	90	100
2SA 683	30	35	40	2SB 600	5.00	6.00	6.60	2SC 871	35	40	45	2SC 1567	80	90	100
2SA 684	35	40	45	2SC 183	40	53	59	2SC 895	4.20	4.40	4.90	2SC 1587A	60	70	80
2SA 695	40	53	59	2SC 184	40	53	59	2SC 898	2.50	2.70	3.00	2SC 1584	6.00	6.30	7.00
2SA 697	40	53	59	2SC 281	30	35	40	2SC 900	20	27	30	2SC 1586	6.50	6.90	7.60
2SA 699A	50	64	70	2SC 283	40	53	59	2SC 923	20	27	30	2SC 1624	60	70	80
2SA 705	40	53	59	2SC 284	80	90	100	2SC 929	20	27	30	2SC 1626	60	70	80
2SA 706	85	1.00	1.10	2SC 317	40	53	59	2SC 930	20	27	30	2SC 1628	60	70	80
2SA 715	60	70	80	2SC 352A	2.00	2.20	2.50	2SC 941	20	27	30	2SC 1647	70	80	90
2SA 719	30	35	40	2SC 353A	1.80	1.60	1.80	2SC 943	35	40	45	2SC 1667	3.00	3.20	3.40
2SA 720	30	35	40	2SC 367	60	70	80	2SC 945	20	27	30	2SC 1669	90	1.00	1.10
2SA 721	30	35	40	2SC 369	30	35	40	2SC 959	1.00	1.20	1.30	2SC 1674	30	35	40
2SA 725	30	35	40	2SC 370	20	27	30	2SC 971	70	80	90	2SC 1675	20	27	30
2SA 726	30	35	40	2SC 371	30	35	40	2SC 982	70	80	90	2SC 1678	1.10	1.25	1.40
2SA 733	20	27	30	2SC 372	20	27	30	2SC 983	50	64	70	2SC 1679	3.00	3.20	3.40
2SA 738	40	53	59	2SC 373	20	27	30	2SC 1000	100	110	120	2SC 1681	70	80	90
2SA 740	1.50	1.70	1.90	2SC 374	30	35	40	2SC 1012	1.20	1.40	1.50	2SC 1682	30	35	40
2SA 743A	35	40	45	2SC 375	30	35	40	2SC 1013	50	64	70	2SC 1688	35	40	45
2SA 744	4.20	4.40	4.90	2SC 377	30	35	40	2SC 1014	50	64	70	2SC 1708	30	35	40
2SA 745R	3.80	4.00	4.40	2SC 380	20	27	30	2SC 1017	80	90	100	2SC 1728	70	80	90
2SA 747	4.20	4.40	4.90	2SC 381	35	40	45	2SC 1018	60	70	80	2SC 1730	45	53	59
2SA 748	70	80	90	2SC 382	35	40	45	2SC 1030	1.60	2.10	2.40	2SC 1756	50	55	60
2SA 750	35	40	45	2SC 383	70	80	90	2SC 1047	35	40	45	2SC 1760	70	80	90
2SA 755	80	90	100	2SC 387A	35	40	45	2SC 1051	3.40	3.55	3.90	2SC 1816	1.50	1.75	1.95
2SA 756	2.30	2.40	2.65	2SC 394	20	27	30	2SC 1061	70	80	90	2SC 1856	45	53	59
2SA 758	3.40	3.55	3.90	2SC 403	30	35	40	2SC 1066	70	80	90	2SC 1885	45	53	59
2SA 764	3.80	4.00	4.40	2SC 430	50	64	70	2SC 1076	30.00	35.00	39.00	2SC 1908	30	35	40
2SA 765	3.10	3.30	3.60	2SC 434	30	35	40	2SC 1079	3.40	3.55	3.90	2SC 1909	1.80	2.00	2.25
2SA 774	40	45	50	2SC 435	30	35	40	2SC 1080	3.00	3.55	3.90	2SC 1945	4.50	5.00	5.60
2SA 777	50	64	70	2SC 458	20	27	30	2SC 1096	45	55	60	2SC 1957	60	70	80
2SA 794A	60	70	80	2SC 460	35	40	45	2SC 1098	50	64	70	2SC 1969	3.60	4.00	4.40
2SA 798	50	55	60	2SC 461	35	40	45	2SC 1111	2.10	2.50	2.80	2SC 1973	70	80	90
2SA 814	70	80	90	2SC 478	60	70	80	2SC 1112	4.20	4.40	4.90	2SC 1975	1.30	1.70	1.90
2SA 815	60	70	80	2SC 481	1.30	1.40	1.50	2SC 1115	2.50	2.70	3.00	2SC 1978	5.40	6.00	6.60
2SA 816	50	64	70	2SC 482	1.10	1.25	1.40	2SC 1116	3.20	3.40	3.70	2SC 2028	50	64	70
2SA 819	70	80	90	2SC 484	1.30	1.40	1.50	2SC 1124	80	90	100	2SC 2029	1.50	1.80	2.00
2SA 837R	2.50	2.70	2.90	2SC 485	1.30	1.40	1.50	2SC 1127	80	90	100	2SC 2074	80	90	100
2SA 839T	1.30	1.45	1.60	2SC 486	1.30	1.40	1.50	2SC 1161	1.30	1.45	1.60	2SC 2076	50	64	70
2SA 908	8.60	8.80	9.80	2SC 493	3.00	3.20	3.40	2SC 1162	20	27	30	2SC 2091	90	110	120
2SA 913	70	80	90	2SC 495	45	55	60	2SC 1166	20	27	30	2SC 2092	1.80	2.00	2.25
2SB 22	30	35	40	2SC 496	45	55	60	2SC 1167	3.80	4.00	4.40	2SC 2098	3.20		

7400 TTL

SN7400N	16	SN7400N	29
SN7401N	18	SN7401N	35
SN7402N	18	SN7402N	35
SN7403N	18	SN7403N	35
SN7404N	18	SN7404N	35
SN7405N	20	SN7405N	5.00
SN7406N	29	SN7406N	99
SN7407N	29	SN7407N	99
SN7408N	29	SN7408N	99
SN7409N	20	SN7409N	35
SN7410N	18	SN7410N	1.75
SN7411N	25	SN7411N	89
SN7412N	25	SN7412N	89
SN7413N	40	SN7413N	60
SN7414N	70	SN7414N	63
SN7415N	25	SN7415N	43
SN7416N	25	SN7416N	43
SN7417N	25	SN7417N	1.95
SN7418N	25	SN7418N	1.95
SN7419N	25	SN7419N	1.95
SN7420N	25	SN7420N	3.00
SN7421N	25	SN7421N	3.00
SN7422N	25	SN7422N	3.00
SN7423N	25	SN7423N	3.00
SN7424N	25	SN7424N	3.00
SN7425N	25	SN7425N	3.00
SN7426N	25	SN7426N	3.00
SN7427N	25	SN7427N	3.00
SN7428N	25	SN7428N	3.00
SN7429N	25	SN7429N	3.00
SN7430N	20	SN7430N	3.00
SN7431N	20	SN7431N	3.00
SN7432N	20	SN7432N	3.00
SN7433N	20	SN7433N	3.00
SN7434N	20	SN7434N	3.00
SN7435N	20	SN7435N	3.00
SN7436N	20	SN7436N	3.00
SN7437N	20	SN7437N	3.00
SN7438N	20	SN7438N	3.00
SN7439N	20	SN7439N	3.00
SN7440N	20	SN7440N	3.00
SN7441N	20	SN7441N	3.00
SN7442N	20	SN7442N	3.00
SN7443N	20	SN7443N	3.00
SN7444N	20	SN7444N	3.00
SN7445N	20	SN7445N	3.00
SN7446N	20	SN7446N	3.00
SN7447N	20	SN7447N	3.00
SN7448N	20	SN7448N	3.00
SN7449N	20	SN7449N	3.00
SN7450N	20	SN7450N	3.00
SN7451N	20	SN7451N	3.00
SN7452N	20	SN7452N	3.00
SN7453N	20	SN7453N	3.00
SN7454N	20	SN7454N	3.00
SN7455N	20	SN7455N	3.00
SN7456N	20	SN7456N	3.00
SN7457N	20	SN7457N	3.00
SN7458N	20	SN7458N	3.00
SN7459N	20	SN7459N	3.00
SN7460N	20	SN7460N	3.00

20% Discount 100 pcs combined order 25% -1000 pcs combined order

C/MOS

CD4001	23	CD4001	55
CD4002	23	CD4002	55
CD4006	1.19	CD4006	1.19
CD4007	25	CD4007	49
CD4009	49	CD4009	99
CD4010	49	CD4010	99
CD4011	23	CD4011	23
CD4012	25	CD4012	99
CD4013	39	CD4013	99
CD4014	1.39	CD4014	1.39
CD4015	1.19	CD4015	1.19
CD4016	49	CD4016	99
CD4017	1.19	CD4017	1.19
CD4018	1.19	CD4018	1.19
CD4019	1.19	CD4019	1.19
CD4020	1.19	CD4020	1.19
CD4021	1.39	CD4021	1.39
CD4022	1.19	CD4022	1.19
CD4023	1.19	CD4023	1.19
CD4024	23	CD4024	23
CD4025	23	CD4025	23
CD4026	2.75	CD4026	2.75
CD4027	59	CD4027	59

74C00

74C00	39	74C163	2.49
74C01	39	74C164	2.49
74C02	39	74C173	2.49
74C03	49	74C182	2.49
74C04	39	74C191	2.49
74C05	39	74C195	2.49
74C06	39	74C196	2.49
74C07	39	74C197	2.49
74C08	39	74C198	2.49
74C09	39	74C199	2.49
74C10	39	74C202	5.95
74C11	39	74C203	6.25
74C12	39	74C204	6.25
74C13	39	74C205	6.25
74C14	1.95	74C206	1.50
74C15	1.95	74C207	1.50
74C16	1.95	74C208	1.50
74C17	1.95	74C209	1.50
74C18	1.95	74C210	1.50
74C19	1.95	74C211	1.50
74C20	1.95	74C212	1.50
74C21	1.95	74C213	1.50
74C22	1.95	74C214	1.50
74C23	1.95	74C215	1.50
74C24	1.95	74C216	1.50
74C25	1.95	74C217	1.50
74C26	1.95	74C218	1.50
74C27	1.95	74C219	1.50
74C28	1.95	74C220	1.50
74C29	1.95	74C221	1.50
74C30	1.95	74C222	1.50
74C31	1.95	74C223	1.50
74C32	1.95	74C224	1.50
74C33	1.95	74C225	1.50
74C34	1.95	74C226	1.50
74C35	1.95	74C227	1.50
74C36	1.95	74C228	1.50
74C37	1.95	74C229	1.50
74C38	1.95	74C230	1.50
74C39	1.95	74C231	1.50
74C40	1.95	74C232	1.50

LINEAR

LM100H	99	LM173H	99
LM100N	89	LM173N	99
LM100CNM	35	LM173CN	1.00
LM100DM	35	LM173DM	1.19
LM100HM	35	LM173HM	1.19
LM100IM	35	LM173IM	1.19
LM100JN	35	LM173JN	1.19
LM100KN	35	LM173KN	1.19
LM100LN	35	LM173LN	1.19
LM100MN	35	LM173MN	1.19
LM100NN	35	LM173NN	1.19
LM100ON	35	LM173ON	1.19
LM100PN	35	LM173PN	1.19
LM100QN	35	LM173QN	1.19
LM100RN	35	LM173RN	1.19
LM100SN	35	LM173SN	1.19
LM100TN	35	LM173TN	1.19
LM100UN	35	LM173UN	1.19
LM100VN	35	LM173VN	1.19
LM100WN	35	LM173WN	1.19
LM100XN	35	LM173XN	1.19
LM100YN	35	LM173YN	1.19
LM100ZN	35	LM173ZN	1.19
LM101H	99	LM174H	99
LM101N	89	LM174N	99
LM101CNM	35	LM174CN	1.00
LM101DM	35	LM174DM	1.19
LM101HM	35	LM174HM	1.19
LM101IM	35	LM174IM	1.19
LM101JN	35	LM174JN	1.19
LM101KN	35	LM174KN	1.19
LM101LN	35	LM174LN	1.19
LM101MN	35	LM174MN	1.19
LM101NN	35	LM174NN	1.19
LM101ON	35	LM174ON	1.19
LM101PN	35	LM174PN	1.19
LM101QN	35	LM174QN	1.19
LM101RN	35	LM174RN	1.19
LM101SN	35	LM174SN	1.19
LM101TN	35	LM174TN	1.19
LM101UN	35	LM174UN	1.19
LM101VN	35	LM174VN	1.19
LM101WN	35	LM174WN	1.19
LM101XN	35	LM174XN	1.19
LM101YN	35	LM174YN	1.19
LM101ZN	35	LM174ZN	1.19

74LS00TTL

74LS00	23	74LS139	69
74LS01	23	74LS151	69
74LS02	23	74LS155	69
74LS03	23	74LS157	69
74LS04	29	74LS160	69
74LS05	29	74LS161	69
74LS06	29	74LS162	69
74LS07	29	74LS163	69
74LS08	29	74LS164	69
74LS09	29	74LS165	69
74LS10	29	74LS166	69
74LS11	29	74LS167	69
74LS12	29	74LS168	69
74LS13	29	74LS169	69
74LS14	29	74LS170	69
74LS15	29	74LS171	69
74LS16	29	74LS172	69
74LS17	29	74LS173	69
74LS18	29	74LS174	69
74LS19	29	74LS175	69
74LS20	29	74LS176	69
74LS21	29	74LS177	69
74LS22	29	74LS178	69
74LS23	29	74LS179	69
74LS24	29	74LS180	69
74LS25	29	74LS181	69
74LS26	29	74LS182	69
74LS27	29	74LS183	69
74LS28	29	74LS184	69
74LS29	29	74LS185	69
74LS30	29	74LS186	69
74LS31	29	74LS187	69
74LS32	29	74LS188	69
74LS33	29	74LS189	69
74LS34	29	74LS190	69
74LS35	29	74LS191	69
74LS36	29	74LS192	69
74LS37	29	74LS193	69
74LS38	29	74LS194	69
74LS39	29	74LS195	69
74LS40	29	74LS196	69
74LS41	29	74LS197	69
74LS42	29	74LS198	69
74LS43	29	74LS199	69
74LS44	29	74LS200	69
74LS45	29	74LS201	69
74LS46	29	74LS202	69
74LS47	29	74LS203	69
74LS48	29	74LS204	69
74LS49	29	74LS205	69
74LS50	29	74LS206	69
74LS51	29	74LS207	69
74LS52	29	74LS208	69
74LS53	29	74LS209	69
74LS54	29	74LS210	69
74LS55	29	74LS211	69
74LS56	29	74LS212	69
74LS57	29	74LS213	69
74LS58	29	74LS214	69
74LS59	29	74LS215	69
74LS60	29	74LS216	69
74LS61	29	74LS217	69
74LS62	29	74LS218	69
74LS63	29	74LS219	69
74LS64	29	74LS220	69

EXCITING NEW KITS!

Regulated Power Supply

5 to 15 VDC

*Full 1.5 amp at 5.0V output - Up to 5 amp at 15V output

*Heavy duty transformer

*3 terminal I.C. Volt, Reg.

*Heat sink provided for cooling efficiency

*PC Board construction

*120 VAC input

*Size: 3 1/4" W x 5 1/8" L x 2 1/8" H

JE210 5 to 15 VDC \$19.95

ALSO AVAILABLE:
JE900 Digital Stopwatch Kit \$39.95
JE301 6 digit Clock Kit \$19.95

JE300 \$39.95

JE730 4 digit Clock Kit \$14.95
JE2206B Fun. Generator Kit \$19.95
JE747 Jumbo 6 digit clock kit \$29.95

DISCRETE LEDS

XC556R	red	5/81	125' dia.	XC209R	red	5/81
XC556G	green	4/81	XC209G	green	4/81	
XC556Y	yellow	4/81	XC209Y	yellow	4/81	
XC556C	clear	4/81	XC209Y	yellow	4/81	

125' dia. 185' dia. 190' dia.

XC22R red 5/81 XC526R red 5/81
XC22G green 4/81 XC526G green 4/81
XC22Y yellow 4/81 XC526Y yellow 4/81
XC22C clear 4/81 XC526C clear 4/81

MV10B red 4/81 XC111R red 5/81
MV10B green 4/81 XC111G green 4/81
MV10B yellow 4/81 XC111Y yellow 4/81
MV10B clear 4/81 XC111C clear 4/81

MV50 red 6/81 XC111R red 5/81
MVS0 red 6/81 XC111G green 4/81
MVS0 yellow 6/81 XC111Y yellow 4/81
MVS0 clear 6/81 XC111C clear 4/81

INFR-RED LED
1/4"x1/4"x1/16" flat 5/81

DISPLAY LEDS

TYPE	POLARITY	HT	PRICE	TYPE	POLARITY	HT	PRICE
MAN 1	Common Anode-red	.270	2.95	MAN 6730	Common Anode-red	.1	560 .99
MAN 2	5 x 7 Dot Matrix-red	300	3.95	MAN 6740	Common Cathode-red-D.D	.6	960 .99
MAN 3	Common Anode-red	.125	2.5	MAN 6750	Common Cathode-red	.1	560 .99
MAN 4	Common Cathode-red	.187	1.95	MAN 6760	Common Cathode-red	.560 .99	
MAN 7G	Common Anode-green	300	1.25	MAN 6760	Common Cathode-red	.560 .99	
MAN 7Y	Common Anode-yellow	300	.99	DL701	Common Anode-red	.1	300 .99
MAN 7C	Common Anode-clear	300	.99	DL704	Common Cathode-red	.300 .99	
MAN 7A	Common Anode-red	300	.99	DL707	Common Anode-red	.300 .99	
MAN 82	Common Anode-yellow	300	.99	DL728	Common Cathode-red	.500 .49	
MAN 8A	Common Cathode-yellow	.300	.99	DL741	Common Anode-red	.600 .125	
MAN 3620	Common Anode-orange	.300	.99	DL746	Common Anode-red	.630 .149	
MAN 3630	Common Anode-orange	.300	.99	DL747	Common Anode-red	.600 .149	
MAN 3640	Common Cathode-orange	.300	.99	DL750	Common Anode-red	.630 .149	
MAN 4610	Common Anode-orange	.300	.99	DL338	Common Cathode-red	.100 .35	
MAN 4640	Common Cathode-orange	.400	.99	FN707	Common Cathode-red	.250 .69	
MAN 4710	Common Anode-red	.400	.99	FN358	Common Cathode-red		

FAIRCHILD RED LED LAMPS

#FLV5057 Medium Size Clear Case. REEMITTING. These are not retested off-spec units as sold by some of our competition. These are factory prime, first quality, new units.



10 FOR \$1.19
50 FOR \$4.95

"WE BOUGHT 250,000 PCS."

"THE COLOSSUS"

FAIRCHILD SUPER JUMBO LED READOUT

A full .80 inch character. The biggest readout we have ever sold! Super efficient. Compare at up to \$2.95 each from others!

YOUR CHOICE \$1.49 EA
FND 847 Common Anode
FND 850 Common Cathode (6 for \$6.95)

NATIONAL SEMICONDUCTOR

NEW!

CAR CLOCK MODULE - #MA6008

Originally used by HYGAIN to indicate time and channel on an expensive C.B. Mini size, self contained module. Not a Kit. Four digits plus flashing indicator for seconds. Includes MM5369 and 3.58 MHZ crystal for super accurate time base. With hookup data.

\$6.99 each

INCLUDES CRYSTAL TIMEBASE!
WORKS ON 12 VDC!

MFGR'S CLOSEOUT
LIMITED QTY.

16K DYNAMIC RAM CHIP

WORKS IN TRS-80 OR APPLE II

16K X 1 Bits, 16 Pin Package. Same as Mostek 4116-4 250 NS access. 410 NS cycle time. Our best price yet for this state of the art RAM. 32K and 64K RAM boards using this chip are readily available. These are new, fully guaranteed devices by a major mfg.

VERY LIMITED STOCK!

"MAGAZINE SPECIAL" — 8 For \$79.50

EXPERIMENTER'S CRYSTAL



262.144KHZ This frequency is 2 to the 18th power. Easily divided down to any power of 2, and even to 1HZ. New by CTS-Knight A \$5 value:

\$1.25 each
4.00 MHZ — \$1.75

MINI PROJECT CASE

Black Molded Plastic 2 1/2 x 1 1/2 in. Has open front, with mounting ears so unit can be easily attached to auto dash, etc. Case has molded card guides for mounting PC board inside. Perfect for digital clocks, car burglar alarms, or almost any electronic project. Can also be used for encapsulating circuits or modules. 75¢ each

Super Special Purchase!

FAIRCHILD PNP "SUPER TRANSISTOR"

2N4402 TO-18 Plastic Silicon PNP Driver High Current VCEO-40 HFE-50 to 150 at 150 MA FT-150 MHZ A Super BEEFED-UP Version of the 2N3906.

8 FOR \$1

G.I. FULL WAVE BRIDGE
4 AMP 600 PIV
3/4 In. Square
With Lugs, #LM-1
75¢ ea. 3 For \$2

MOTOROLA POWER TRIAC
TO-220 CASE
15 AMP 400 PRV
SPECIAL 89¢ each
5 FOR \$3.95

COMPLEMENTARY POWER TRANSISTORS

SILICON NPN AND PNP. TO-220 CASE. VCEO - 40V PD - 30 WATTS FOR AUDIO POWER AMPS, ETC.

TIP29 - NPN YOUR CHOICE
TIP30 - PNP 3 FOR \$1

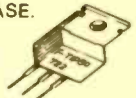

FET SALE!

2N4304. Brand New N Channel. Junction Fet. BVGD0-30V IDSS-15 MA Typ. 1500 uMHOS. TO-18 Plastic Case. Mfg. by Teledyne.
6 FOR \$1

EXPERIMENTER'S HEATING PLATE
Large Manufacturers Surplus. 5x10 1/2 In. Made of 3/8 in. tempered glass with heating element laminated on back. Works off 120 VAC. Protected by thermostat and two thermal fuses. Rated 120 watts. Use for any heating applications. Perfect for heating ferric chloride to increase PC board etching efficiency. Units are brand new, non-submersible.
WHILE THEY LAST — \$2.99 each

SONY 30 WATT AUDIO AMP MODULE

#STK-056. 30 WATTS SUPER CLEAN AUDIO. 20 HZ to 100 KHZ ± 2 DB. HYBRID, SILICON, SELF-CONTAINED MODULE. ONLY 1 1/2 x 2 1/2 IN. WITH DATA. COMPARE AT UP TO TWICE OUR PRICE!
\$9.99 EACH

Digital Research Corporation

(OF TEXAS)
P.O. BOX 401247B GARLAND, TEXAS 75040 • (214) 271-2461

TERMS: Add 30¢ postage, we pay balance. Orders under \$15 add 75¢ handling. No C.O.D. We accept Visa, MasterCard, and American Express cards. Tex. Res. add 5% Tax. Foreign orders (except Canada) add 20% P & H. 90 Day Money Back Guarantee on all items.

RHYTHM GENERATOR ROM
PRE-PROGRAMMED ROM HAS 8 RHYTHM PATTERNS STORED THAT ARE "WALKED OUT" WITH A CMOS COUNTER. (E.G., DANCE, CHANGE RHYTHM WITH A SWITCH, 6 OUTPUTS. GREAT FUN TO PLAY WITH. WITH DATA.
\$1.89

FND-359
0.5" COMMON CATH. RED LED DISPLAY IS A PERFECT CHOICE FOR THE ICM7208. GOOD BRIGHTNESS, LOW CURRENT.
69¢
7/430

CRYSTALS
1.000MHZ .001% \$5.95
3.579MHZ .002% \$1.25
4.000MHZ .002% \$2.98
5.000MHZ .001% \$4.50
10.00MHZ .001% \$4.50
88¢

LM340K-5
5 VOLT, 1-1/2 AMP REGULATOR IN A TO-3 PKG. OUR PRICE IS BEST IN TOWN!
88¢

LM3900
QUAD NORTON AMP BY NAT'L 16 PIN DIP.
55¢

CMOS CIRCUITRY - LED DISPLAY
WOW! DIGITAL TIMER-COUNTER
POWER WITH 9V BATTERY
IC'S ALONE WORTH \$9!
4011, 4000, 4511, 4553
COMPACT: 1 1/2 x 2" PCB
D-2740
WHEN UNIT IS SWITCHED ON, DISPLAY READS "00" WHEN "START" IS PUSHED, THE DISPLAY FLASHES "HYPHENS" --- 24 TIMES, AND INCREMENTS TO "01" AND STOPS. PUSHING ANOTHER "START", EACH TIME "START" IS PRESSED CYCLE REPEATS AND THE "START" IS INCREMENTED 1 COUNT TO A TOTAL OF 99. CYCLE TIME IS VARIABLE APPROX 1-30 SECONDS WITH QUADRYN FINDER (CHECK LONGER BY ADDING SMALL CAPACITORS. GREAT FOR INSTANT PHOTO TIMER, TELEPHONE TIMER, ALL SORTS OF GADGETS. LET YOUR IMAGINATION GO!
ASSEMBLED TIMER-COUNTER INCLUDES 9V BATTERY CLIP, ON-OFF SWITCH, PROHIBITION START SWITCH, JUST ATTACH A BATTERY & COUNT!
\$3.95
2/7

Build a 7 Digit Portable Counter
WITH 12 PAGES OF DATA...
MEASURE FREQUENCY, PERIOD, EVENTS...
SINGLE 3-6V SUPPLY...
DIRECT DRIVE TO CC LEADS...
0,1 AND 1 SECOND GATE
FREQUENCY COUNTER CHIP SET
ICM 7207A \$2150
ICM 7208
SUPER 2 CHIP SET WILL ALLOW YOU TO BUILD A 7 DIGIT, 2 RANGE FREQUENCY COUNTER WITH JUST A CRYSTAL, DISPLAY, AND 6 RPN & C's !!
THE ICM7207A IS THE OSCILLATOR/CONTROLLER WHICH PROVIDES A STABLE 5 MHz OSCILLATOR AND ALL SIGNAL GATING FOR THE 7208. THE ICM7208 IS A COMPLETE 7 DECADE COUNTER-DECODER-DRIVER WITH DIRECT DRIVE TO LED DISPLAYS. BOTH IC'S OPERATE OFF A SINGLE 3 TO 6 VOLT SUPPLY. AT ABOUT 1 MA CURRENT DRAIN !!
THIS CHIP SET MAKES FULL FUNCTION TEST BENCH COUNTERS, PORTABLE BATTERY OPERATED COUNTERS, OR FREQUENCY READOUTS FOR YOUR TRANSMITTERS, GENERATORS, OR RECEIVERS A SNAP TO BUILD! 82 PAGES OF DATA INCLUDED WITH CHIP SET.



THE PRATT READ ELECTRONIC KEYBOARDS

ELECTRONIC KEYBOARDS FOR HOME ORGANS AND SYNTHESIZERS

SEND FOR FREE BROCHURE.

Pratt, Read & Co., Ivoryton, Connecticut 06442
Please send free Electronic Keyboard brochure to:

Name _____
Street Address _____
City _____ State _____ Zip _____

"FIRE SALE"
ASSEMBLED & TESTED
PHOTOELECTRIC TYPE
117VAC - NO BATTERY TO BUY!
4A 400V SCR OUTPUT
SMOKE ALARM G-1012
"HOT" DEAL ON THE QUIET (LESS BELL) FROM A POP US MFR. OF SMOKE ALARMS. BOARD CAN BE EASILY PUT INTO SERVICE AS A SENSITIVE SMOKE DETECTOR, OR USED FOR A NUMBER OF LIGHT SENSITIVE GADGETS SUCH AS BURGLAR ALARMS, LIGHT RELAYS, EVEN FLASHERS! TO USE, CONNECT 117VAC DIRECTLY TO BOARD (LUMINEOUS DRAIN IS ONLY 10MA), AND ATTACH A LOAD (BELL, BUZZER, LAMP, ETC.) UP TO 4 AMPS TO THE OUTPUT. AS LONG AS A SMALL AMOUNT OF LIGHT IS ALLOWED TO FALL ON THE PHOTOTRANSISTOR, THE UNIT REMAINS "OFF". AS SOON AS THE LIGHT DROPS BELOW A MINIMUM LEVEL, THE OUTPUT BEGINS TO CYCLE ON & OFF AT A 1 HZ RATE UNTIL CAN BE CHANGED TO CAUSE OUTPUT TO REMAIN ON INSTEAD OF PULSING. ALARM FEATURES ZENER REGULATION, SENSITIVE FET, SCR OUTPUT, PHOTOTRANSISTOR, ASSEMBLED & TESTED, WITH SCHEMATIC.
\$1.79
2/43

5.24288MHZ Quartz Crystal
PRECISION "AT" CUT QUARTZ CRYSTAL DESIGNED FOR USE WITH ICM7207A TO PROVIDE A STABLE 40,000'S TIMEBASE. RE-10 CASE, WIRE LEADS.
450
6-36pf Trimmer ONLY 49¢
0-3311

NE-2 NEON PILOT LAMPS
4-1020
OPERATE OFF AC LINE, MAKE FLASHERS, VISIBLE FLIP FLOPS, ETC...
10/\$1

"OUR FIFTH YEAR"
DIAMONDBACK ELECTRONICS COMPANY
PO BOX 194
SPRING VALLEY, IL 61362
...FREE CATALOG...
ALL MERCHANDISE 100% GUARANTEED MINIMUM ORDER \$5
ILL RESIDENTS ADD 5% SALES TAX PLEASE INCLUDE SUFFICIENT POSTAGE
PHONE ORDERS 815/664-5151

RADIO-ELECTRONICS

TRS-80 E.S. SERIAL I/O

- Can input into basic
- Can use LLIST and LPRINT to output, or output continuously
- RS-232 compatible
- Can be used with or without the expansion bus
- On board switch selectable baud rates of 110, 150, 300, 600, 1200, 2400, parity or no parity odd or even, 5 to 8 data bits, and 1 or 2 stop bits. D.T.R. line
- Requires +5, -12 VDC
- Board only \$19.95 Part No. 8010, with parts \$59.95 Part No. 8010A, assembled \$79.95 Part No. 8010C. No connectors provided, see below.

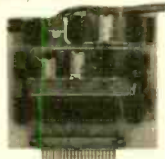

EIA/RS-232 connector Part No. DB25P \$6.00 with 9' 8 conductor cable \$10.95 Part No. DB25P9



3' ribbon cable with attached connectors to fit TRS-80 and our serial board \$19.95 Part No. 3CAB4C

MODEM*

- Type 103
- Full or half duplex
- Works up to 300 baud
- Originate or Answer
- No coils, only low cost components
- TTL input and output-serial
- Connect B & speaker and crystal mic. directly to board
- Uses XR FSK demodulator
- Requires +5 volts
- Board only \$7.60 Part No. 109, with parts \$27.50 Part No. 109A



VERBATIM MINIDISK



Box of 10 \$29.95

RS-232/ TTL* INTERFACE

- Converts TTL to RS-232, and converts RS-232 to TTL
- Two separate circuits
- Requires -12 and +12 volts
- All connections go to a 10 pin gold plated edge connector
- Board only \$4.50 Part No. 232, with parts \$7.00 Part No. 232A 10 Pin edge connector \$3.00 Part No. 10P



RS-232/ TTY* INTERFACE

- Converts RS-232 to 20mA current loop, and 20mA current loop to RS-232
- Two separate circuits
- Requires +12 and -12 volts
- Board only \$4.50 Part No. 600, with parts \$7.00 Part No. 600A

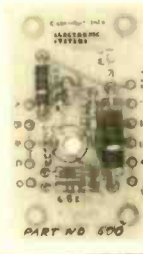

APPLE II* SERIAL I/O INTERFACE



Baud rate is continuously adjustable from 0 to 30,000

- Plugs into any peripheral connector
- Low current drain. RS-232 input and output
- On board switch selectable 5 to 8 data bits, 1 or 2 stop bits, and parity or no parity either odd or even
- Jumper selectable address
- SOFTWARE
- Input and Output routine from monitor or BASIC to teletype or other serial printer
- Program for using an Apple II for a video or an intelligent terminal. Also can output in correspondence code to interface with some electricics.
- Also watches DTR
- Board only \$15.00 Part No. 2, with parts \$42.00 Part No. 2A, assembled \$62.00 Part No. 2C

8K EPROM PIICEON

Saves programs on PROM permanently (until erased via UV light) up to 8K bytes. Programs may be directly run from the program saver such as fixed routines or assemblers.

- S-100 bus compatible
- Room for 8K bytes of EPROM non-volatile memory (2708's).
- On-board PROM programming
- Address relocation of each 4K of memory to any 4K boundary within 64K
- Power on jump and reset jump option for "turnkey" systems and computers without a front panel
- Program saver software available
- Solder mask both sides
- Full silkscreen for easy assembly. Program saver software in 1 2708 EPROM \$25. Bare board \$35 including custom coil, board with parts but no EPROMS \$139, with 4 EPROMS \$179, with 8 EPROMS \$219.

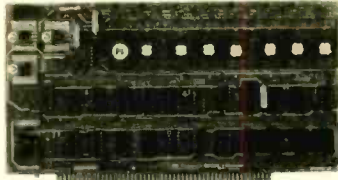

WAMECO INC.

WAMECO INC.

- FDC-1 FLOPPY CONTROLLER BOARD** will drive shugart, pertek, remic 5" & 8" drives up to 8 drives, on board PROM with power boot up, will operate with CPM (not included). PCB \$42.95
- FPB-1 Front Panel.** (Finally) AMSAI size hex displays. Byte or instruction single step. PCB \$42.95
- MEM-1A 8Kx8** fully buffered, S-100, uses 2102 type RAMS. \$24.95, \$168 Kit
- QMB-12 MOTHER BOARD,** 13 slot, terminated, S-100 board only \$34.95
- QMB-9 MOTHER BOARD,** 9 slots \$89.95 Kit
- CPU-1 8080A Processor board** S-100 with 8 level vector interrupt PCB \$25.95 \$89.95 Kit
- RTC-1 Realtime clock board.** Two independent interrupts. Software programmable. PCB \$25.95, \$60.95 Kit
- EPM-1 1702A 4K EPROM** card PCB \$25.95 \$49.95 with parts less EPROMS
- EPM-2 2708/2716 16K/32K EPROM card PCB** \$24.95 \$49.95 with parts less EPROMS
- QMB-9 MOTHER BOARD.** Short Version of QMB-12. 9 Slots PCB \$30.95 \$67.95 Kit
- MEM-2 16Kx8 Fully Buffered 2114 Board PCB** \$25.95, \$269.95 Kit

T.V. TYPEWRITER

- Stand alone TVT
- 32 char/line, 16 lines, modifications for 64 char/line included
- Parallel ASCII (TTL) input
- Video output
- 1K on board memory
- Output for computer controlled cursor
- Auto scroll
- Non-destructive cursor
- Cursor inputs: up, down, left, right, home, EOL, EOS
- Scroll up, down
- Requires +5 volts at 1.5 amps, and -12 volts at 30 mA
- All 7400, TTL chips
- Char. gen. 2513
- Upper case only
- Board only \$39.00 Part No. 106, with parts \$145.00 Part No. 106A



TAPE * INTERFACE

- Play and record Kansas City Standard tapes
- Converts a low cost tape recorder to a digital recorder
- Works up to 1200 baud
- Digital in and out are TTL-serial
- Output of board connects to mic. in of recorder
- Earphone of recorder connects to input on board
- No coils
- Requires +5 volts, low power drain
- Board only \$7.60 Part No. 111, with parts \$27.50 Part No. 111A



UART & BAUD RATE GENERATOR*

- Converts serial to parallel and parallel to serial
- Low cost on board baud rate generator
- Baud rates: 110, 150, 300, 600, 1200, and 2400
- Low power drain +5 volts and -12 volts required
- TTL compatible
- All characters contain a start bit, 5 to 8 data bits, 1 or 2 stop bits, and either odd or even parity.
- All connections go to a 44 pin gold plated edge connector
- Board only \$12.00 Part No. 101, with parts \$35.00 Part No. 101A, 44 pin edge connector \$4.00 Part No. 44P

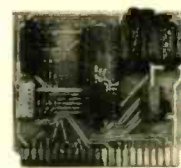

HEX ENCODED KEYBOARD E.S.

This HEX keyboard has 19 keys, 16 encoded with 3 user definable. The encoded TTL outputs, 8-4-2-1 and STROBE are debounced and available in true and complement form. Four onboard LEOs indicate the HEX code generated for each key depression. The board requires a single +5 volt supply. Board only \$15.00 Part No. HEX-3, with parts \$49.95 Part No. HEX-3A. 44 pin edge connector \$4.00 Part No. 44P

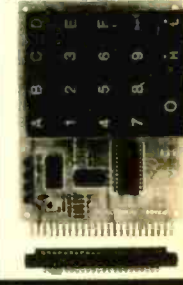

S-100 BUS * ACTIVE TERMINATOR

Board only \$14.95 Part No. 900, with parts \$24.95 Part No. 900A



DC POWER SUPPLY*

- Board supplies a regulated +5 volts at 3 amps., +12, -12, and -5 volts at 1 amp.
- Power required is 8 volts AC at 3 amps., and 24 volts AC C.T. at 1.5 amps.
- Board only \$12.50 Part No. 60B5, with parts excluding transformers \$42.50 Part No. 60B5A



To Order:

Mention part number, description, and price. In USA, shipping paid for orders accompanied by check, money order, or Master Charge, BankAmericard, or VISA number, expiration date and signature. Shipping charges added to C.O.D. orders. California residents add 6.5% for tax. Outside USA add 10% for air mail postage and handling, no C.O.D.'s. Checks and money orders must be payable in US dollars. Parts kits include sockets for all ICs, components, and circuit board. Documentation is included with all products. Prices are in US dollars. No open accounts. To eliminate tariff in Canada boxes are marked "Computer Parts." Dealer inquiries invited. 24 Hour Order Line: (408) 226-4064



* Circuits designed by John Bell

For free catalog including parts lists and schematics, send a self-addressed stamped envelope.

ELECTRONIC SYSTEMS

Dept. RE5, P. O. Box 21638, San Jose, CA USA 95151

CARBON FILM 1/4W-5% Resistors

OHMS	OHMS	OHMS	OHMS	OHMS	OHMS	OHMS	OHMS	OHMS
2.7	11	47	200	820	3600	15K	62K	270K
3.0	12	51	220	910	3900	16K	68K	300K
3.3	13	56	240	1000	4300	18K	75K	330K
3.6	15	62	270	1100	4700	20K	82K	360K
3.9	16	68	300	1200	5100	22K	91K	390K
4.3	18	75	330	1300	5600	24K	100K	430K
4.7	20	82	360	1500	6200	27K	110K	470K
5.1	22	91	390	1600	6800	30K	120K	510K
5.6	24	100	430	1800	7500	33K	130K	560K
6.2	27	110	470	2000	8200	36K	150K	620K
6.8	30	120	510	2200	9100	39K	160K	680K
7.5	33	130	560	2400	10K	43K	180K	750K
8.2	36	150	620	2700	11K	47K	200K	820K
9.1	39	160	680	3000	12K	51K	220K	910K
10	43	180	750	3300	13K	56K	240K	1.0M

HIGH QUALITY... LOW O.E.M. PRICE

5 for .25 | 10 for .40 | 100-\$1.60 - 1000 at \$1.4.

CMOS BOARD \$2.95
 CONTAINS:
 4553 3 digit decade counter
 4511 4bit latch 7 seg. decoder
 driver for LED display
 4060 oscillator w/1/2 stage binary counter.
 4011 CMOS gate
 2 switches, resistors, capacitors.
 HP 7 digit LED display

RCA to 220 8A, 600V TRIAC ea. 99¢ ten-\$9.50 \$89/c

BISTABLE RELAY OPTO ISOLATOR 6 or 8 SIGNAL DIODES
 FCD820 6pin DIP High quality, married computer grade signal diodes. Leads trimmed for PCB mounting....
 WILL DRIVE A TTL GATE WITH TEN MA LED CURRENT

VOICE ACTUATED SWITCH 95¢ ea
 COMPLETELY ASSEMBLED ON CONCRETE BOARD AS OPEN CIRCUITING CENTRAL SWITCHING DEVICE. SOUND SENSITIVE. TRANSDUCER AMP/DRIVER AND 4 AMP. SW. MOTOR ON 1/2 WATT. ON BY ADDED FROM MICROPHONE..... REQUIRES 5-15 VDC FROM POWER SUPPLY.
 MICROPHONE CAN BE REPLACED BY CDS PHOTOCELL FOR LIGHT ACTUATION.....
40¢ ea. \$3.10

TRANSISTOR BONANZA
 PRIME TO-18 PLASTIC TRANSISTORS FROM A REPUTABLE SEMI CONDUCTOR MANUFACTURER. THESE ARE FIRST QUALITY DEVICES MADE FOR A COMPUTER FIRM. THE WIRE IS CUT AND FORMED LEADS (TO-S SHAPE), AND THE PINS ARE FULL LENGTH LEADS. SPECIFY NPN OR PNP. 50 PER CENT REFUND.....
\$6 for 100 \$50-k

DIODE ARRAY 1N1914's special
 20K ea. \$1.10 \$11.50
 100 ea. \$12.50/c
 CLEARIX
 25¢ each
 10 - \$2.25

ONE AMP OP-AMP
 HIGH POWER APPLICABLE IN HIGH SPEED LOGIC
\$4.50 5/20

THERMISTOR
 250 OHMS @ 25C
25¢ ea. 10-\$2

DIP TRIMMER
 12 TURN 1/4" x 1/8"
 5K or 200K only
 mg. DALE
\$1.50 TEN FOR \$4

1/2 WATT RESISTORS
 10 ea. - 390, 1.0K, 3.9K, 6.8K, 11K
 43K, 68K, 240K - 5 percent tol.

80 FOR \$4
POTTER BRUMFIELD
 4TYPE KHP RELAY
 400V 1AMP
 24VDC 650 ohms cr.
 120VAC 10.59VA
 Please specify coil required.
\$1.75

Numeric Display
 1/2" Single Digit
 GAS P LED
 COMMON CATHODE WITH 10000 HOUR DECIMAL POINT LIGHTING. BRIGHT RED OR CHARACTERISTIC BLUE WITH 10000 HOUR OPERATING LIFE. VOLTAGE 1.8V-2.0V PER SEGMENT AT TYPICAL CURRENTS.
65¢ each - 10 for \$5.95

VARO SEMICONDUCTOR
 10 AMP 50V RECTIFIERS
 10 ea. 10 for \$7.50 100-505

PO BOX 41778 Sacramento California 95841
 SEND FOR FREE FLYER TODAY
 \$5 minimum order, add \$1 handling charge to orders less than \$10. We pay post or UPS on domestic orders over \$10. 84¢ MC and VISA accepted. \$15 shipping and shipping is added. open accounts accepted from government entities and large retail firms. Same day shipment. Telephone (916) 334-2181 4111 Myrtle Avenue, Sacramento, CA 95841

BABYLON ELECTRONICS ORDER NOW!
 CIRCLE 60 ON FREE INFORMATION CARD

Cramped for Antenna space?



The McKay DYMEK DA 100.

The DA 100 is a compact, wide dynamic range, broadband, untuned, omni-directional receiving antenna covering the frequency range of 50 kHz to 30 MHz.

The exterior module, a small weather-proof box with a 56 inch (142 cm) whip delivers the signal to the power supply unit through a supplied 50' coaxial cable.

The power supply locates near your general coverage receiver and attaches with a supplied patch cord.

The DA 100 antenna is small, but will equal or outperform a 100' long wire antenna, and is priced within reach of everyone!

Output Impedance - Attenuator Switch provided to match receiver input requirements and prevent overload.

Order factory Direct. Call toll free today! Money Back guarantee. Rent/Own Plan available. Specs and details on request.

Nationwide 800/854-7769
 California 800/472-1783

McKay Dymek Co.
 111 S. Colledge Ave., PO Box 5000
 Claremont CA 91711
CIRCLE 65 ON FREE INFORMATION CARD

16K MEMORY EXPANSION CHIP SET \$109 (3/\$320)

For Radio Shack-80, Apple, Sorcerer machines. 250 ns chips for 4 MHz operation, DIP shunts, 1 year limited warranty. Includes easy-to-follow instructions.

MA1003 CLOCK AND CASE: \$19.95!!

Easy to build — just add 12V DC and time set switches. Ideal for mobile use. Blue-green fluorescent readouts. Case available separately for \$5.95; clock module for \$16.50.

STATIC COMPUTER MEMORY — NOW WITH BANK SELECT MODELS!

Most Econoram™ are available as unkits (sockets, bypass caps pre-soldered in place), assembled and tested, or qualified under the Certified System Component (CSC) high-reliability program.

We've been providing top quality memory (without charging top dollar) for over 5 years — see your computer store or our flyer for more info.

Name	Bus	Speed	Unkit	Assem	CSC
8K Econoram I™	S-100	2 MHz	\$149	\$164	N/A
16K Econoram IV™	S-100	4 MHz	\$295	\$329	\$429
12K Econoram V™	HB	2 MHz	\$200	\$270	N/A
24K Econoram VII™	S-100	4 MHz	\$445	\$485	\$605
32K Econoram IX™	Dig Grp	4 MHz	\$649	N/A	N/A
32K Econoram X™	S-100	4 MHz	\$599	\$649	\$789
32K Econoram XI™	SBC	4 MHz	N/A	N/A	\$1050
16K Econoram XII-16™	S-100*	4 MHz	\$369	\$419	\$519
24K Econoram XII-24™	S-100*	4 MHz	\$479	\$539	\$649
32K Econoram XIII™	S-100*	4 MHz	\$629	\$699	\$849

*Bank select board — has two independently addressable and selectable banks (for Alpha Micro Systems, Marlinchip, etc.).

GODBOUT
 BILL GODBOUT ELECTRONICS
 BOX 2335 OAKLAND AIRPORT CA 94614
 TERMS: Cal. res. add tax. VISA®/Mastercharge® call 24 hr. order desk at (415) 562-0636. Allow 5% shipping, excess refunded. COD OK with street address for UPS. Prices good through cover month of magazine. Orders under \$15 add \$1 handling.
SEND FOR OUR HOT-OFF-THE-PRESSES CATALOGUE, YOU'LL BE GLAD YOU DID.
CIRCLE 53 ON FREE INFORMATION CARD

AMAZING EARADIO
 THIS IS PROBABLY THE WORLD'S SMALLEST RADIO. IT WEIGHS ONLY 1/2 OUNCE AND IS WORN BEHIND THE EAR. CONTAINS AN IC AND SEVERAL DISCRETE DEVICES TO GIVE AN EQUIVALENT OF 12 TRANSISTORS. THE RADIO HAS A T.R.F. DESIGN OPERATING FROM 1 STANDARD SIZE 1.5V HEARING AID BATTERY (INCLUDED). IT PROVIDES GOOD VOLUME TO EARPHONES ON SEVERAL STATIONS IN METROPOLITAN AREAS. DOESN'T REQUIRE ANY ANTENNA, GROUND OR OTHER ADDITIONAL WIRES — FULLY SELF CONTAINED & TUNABLE. SIZE: 1 1/8" x 1 1/8" x 3/8".
\$5.95

Crystal 14.04 Mhz Oscillator IC clock oscillator
 C23289 \$1.98

V.O.X. Solid state Voice Operated Switch Complete and assembled with schematic
 \$99¢

LED PANEL MOUNTING KIT 12 PIN 1/2"
 MICRO-RELAY SWITCH 1 POLE 3 POSITION 270V
SEND FOR YOUR FREE CATALOG

Electronic Warning Flasher Kit
 This battery operated device continuously emits bursts of intense light. Great safety device for bicycle riders, skiers, hikers, boaters & campers. Comes complete w/ all electronic parts, quality glass epoxy P-C board & easy to understand instructions. Uses high-output xenon flash tube which flashes 2 times per second when batteries are fresh. Operates continuously for 12 hours on 2 alkaline "C" batteries and, if desired, a battery holder & case.
C23207 \$6.95

Stroke Light Kit COMPLETE 4-pin probe
 Night light kit complete with 4-pin probe, including line cord, PC board, and 177VAC 750mA

6 MV TRIGGER COILS 2 for \$1 required to "fire" xenon flash tubes

SLA-1 7 SECTORED LOW-PIN ANODE READOUT CHARACTERISTICS: 33A, 1.5" PIN, SEALED PUMP, 6 for \$2.00

save on gas!
 Enjoy the benefits of 20% better gas mileage, quicker starting, elimination of tune-ups, reduced pollution, and 50,000 miles on plugs and points.
 Update your car with a TIGER solid state electronic ignition system. Easily installed in 30 minutes — even on new cars.
Tiger 500 CD Assembled \$49.95 Simplitik \$29.95

Postpaid USA.
 Master Charge & BankAmericard accepted.
Tri-Star Corporation
 Phone (303) 243-5200
 P.O. Box 1727
 Grand Junction, Colorado 81501
CIRCLE 66 ON FREE INFORMATION CARD

PHOTOFILM CAPS
 350ml 330V 1.00
 720ml 360V 1.50
 1600 ml 360V \$2.25

JUMBO RED LED
 FROSTED WHITE LENS
10 for \$1

STROBE TUBE ASST. Brand new factory prime strobe tubes. Assortment of 5 strobe tubes, w/ schematics
 C23280 \$3.00

HIGHLY POLISHED REFLECTOR FOR STROBE TUBES
 C23451 \$2.49

CHANEY electronics
 P.O. BOX 27038, DENVER, CO. 80227 Ph: (303) 781-5750
 Send for our FREE GIANT CATALOG of unique items!!!!

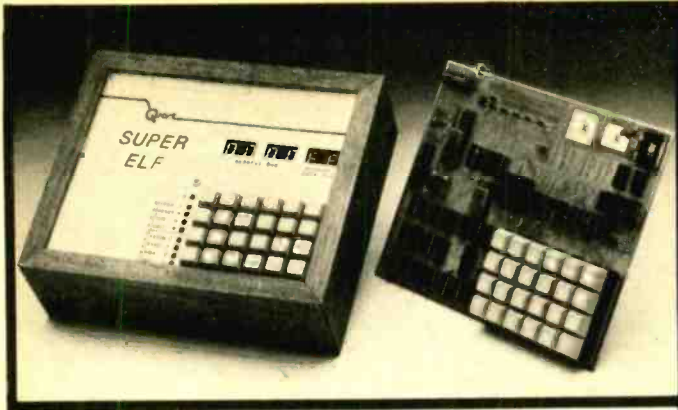

RCA Cosmac Super Elf Computer \$106.95

Compare features before you decide to buy any other computer. There is no other computer on the market today that has all the desirable benefits of the Super Elf for so little money. The Super Elf is a small single board computer that does many big things. It is an excellent computer for training and for learning programming with its machine language and yet it is easily expanded with additional memory, Tiny Basic, ASCII Keyboards, video character generation, etc.

The Super Elf includes a ROM monitor for program loading, editing and execution with SINGLE STEP for program debugging which is not included in others at the same price. With SINGLE STEP you can see the microprocessor chip operating with the unique Quest address and data bus displays before, during and after executing instructions. Also, CPU mode and instruction cycle are decoded and displayed on nine LED indicator lamps.

An RCA 1861 video graphics chip allows you to connect to your own TV with an inexpensive video modulator to do graphics and games. There is a speaker system included for writing your own music or using many music programs already written. The speaker amplifier may also be used to drive relays for control purposes.

Super Expansion Board with

This is truly an astounding value! This board has been designed to allow you to decide how you want it optioned. The Super Expansion Board comes with 4K of low power RAM fully addressable anywhere in 64K with built-in memory protect and a cassette interface. Provisions have been made for all other options on the same board and it fits neatly into the hardware cabinet alongside the Super Elf. The board includes slots for up to 6K of EPROM (2708, 2758, 2716 or TI 2716) and is fully socketed. EPROM can be used for the monitor and Tiny Basic or other purposes.

A 1K Super ROM Monitor \$19.95 is available as an on board option in 2708 EPROM which has been preprogrammed with a program loader/editor and error checking multi file cassette read/write software. (relocatable cassette file) another exclusive from Quest. It includes register save and readout, block move capability and video graphics driver with blinking cursor. Break points can be used with the register save feature to isolate program bugs quickly. Then follow with single step. The Super Monitor is written with subroutines allowing users to take advantage of monitor functions simply by calling them up.

plus load, reset, run, wait, input, memory protect, monitor select and single step. Large on board displays provide output and optional high and low address. There is a 44 pin standard connector for PC cards and a 50 pin connector for the Quest Super Expansion Board. Power supply and sockets for all IC's are included in the price plus a detailed 90 page instruction manual.

Many schools and universities are using the Super Elf as a course of study. OEM's use it for training and research and development.

Remember, other computers only offer Super Elf features at additional cost or not at all. Compare before you buy. Super Elf Kit \$106.95. High address option \$8.95. Low address option \$9.95. Custom Cabinet with drilled and labelled plexiglass front panel \$24.95. NiCad Battery Memory Saver Kit \$6.95. All kits and options also come completely assembled and tested. Questdata, a 12 page monthly software publication for 1802 computer users is available by subscription for \$12.00 per year.

Tiny Basic for ANY 1802 System
Cassette \$10.00. On ROM \$38.00. Super Elf owners, 30% off. Object code listing with manual \$5.00. Object list, manual and paper tape \$10.00. Original ELF Kit Board \$14.95.

Cassette Interface \$89.95

Improvements and revisions are easily done with the monitor. If you have the Super Expansion Board and Super Monitor the monitor is up and running at the push of a button.

Other on board options include Parallel Input and Output Ports with full handshake. They allow easy connection of an ASCII keyboard to the input port. RS 232 and 20 ma Current Loop for teletype or other device are on board and if you need more memory there are two S-100 slots for static RAM or video boards. A Godbout 8K RAM board is available for \$135.00. Also a 1K Super Monitor version 2 with video driver for full capability display with Tiny Basic and a video Interface board. Parallel I/O Ports \$9.85, RS 232 \$4.50, TTY 20 ma I/F \$1.95, S-100 \$4.50. A 50 pin connector slot with ribbon cable is available at \$12.50 for easy connection between the Super Elf and the Super Expansion Board.

The Power Supply Kit for the Super Expansion Board is a 5 amp supply with multiple positive and negative voltages \$29.95. Add \$4.00 for shipping. Prepunched frame \$5.00. Case \$10.00. Add \$1.50 for shipping.

Auto Clock Kit \$15.95
DC clock with 4-50" displays. Uses National MA-1012 module with alarm option. Includes light dimmer, crystal timebase PC boards. Fully regulated, comp. instrs. Add \$3.95 for beautiful dark gray case. Best value anywhere.

RCA Cosmac VIP Kit \$229.00
Video computer with games and graphics. Fully assem. and test. \$249.00

Not a Cheap Clock Kit \$14.95
Includes everything except case, 2-PC boards, 6-50" LED Displays, 5314 clock chip, transformer, all components and full instructions. Orange displays also avail. Same kit w/80" displays. Red only. \$21.95 Case \$11.75

60 Hz Crystal Time Base Kit \$4.40
Converts digital clocks from AC line frequency to crystal time base. Outstanding accuracy. Kit includes: PC board, IC, crystal, resistors, capacitors and trimmer.

Digital Temperature Meter Kit
Indoor and outdoor. Switches back and forth. Beautiful 50" LED readouts. Nothing like it available. Needs no additional parts for complete, full operation. Will measure -100 to +200 F. tenths of a degree, air or liquid. Very accurate. \$39.95
Beautiful woodgrain case w/bezel \$11.75

NiCad Battery Fixer/Charger Kit
Depos shorted cells that won't hold a charge and then charges them up. all in one kit w/full parts and instructions. \$7.25

PROM Eraser Will erase 25 PROMs in 15 minutes. Ultraviolet, assembled. \$34.50

Rockwell AIM 65 Computer
6502 based single board with full ASCII keyboard and 20 column thermal printer 20 char. alphanumeric display. ROM monitor. fully expandable. \$375.00. 4K Assembler \$85.00, 8K Basic Interpreter \$100.00. Power supply assembled in case \$60.00.

Same day shipment. First line parts only. Factory tested. Guaranteed money back. Quality IC's and other components at factory prices.

INTEGRATED CIRCUITS

7400TL	1.15	LM337T	3.00	CD4583	3.50
7400N	17	LM337	3.00	CD4585	2.25
7400P	17	LM337	3.00	CD4585	4.50
7404N	19	LM339N	1.00	CD4583	4.50
7409N	23	LM381	1.50	CD40192	3.00
7410N	17	LM322	1.00	74C00	2.25
7414N	83	LM703H	42	74C00	2.25
7420N	17	LM709H	28	74C04	3.25
7422N	1.39	LM733N	2.00	74C10	2.25
7423N	20	LM733N	2.00	74C14	2.10
7424N	50	LM741Ch	37	74C20	2.25
7425N	69	LM741N	25	74C30	2.25
7427N	80	LM7479N	62	74C48	1.95
7428N	69	LM748N	35	74C76	1.40
7429N	17	LM753N	82	74C76	1.40
7474N	29	LM1304	1.10	74C90	1.15
7475N	49	LM1305	1.27	74C93	1.40
7485N	88	LM1307	2.00	74C154	3.00
7489N	2.00	LM1310	2.75	74C160	1.44
7490N	43	LM1458	1.75	74C175	1.35
7492N	43	LM1600	1.75	74C192	1.65
7493N	43	LM1812	1.75	74C221	2.00
7495N	69	LM1839	3.00	74C905	3.00
74100N	80	LM1181	7.50	74C906	3.00
74107N	29	LM2907	1.50	74C907	1.50
74117N	34	LM3909N	1.75	74C923	3.50
74120N	59	LM5455V	50	74C922	6.95
74125N	39	LM3909N	1.75	74C925	6.95
74130N	59	NE540L	2.89	74C927	6.95
74131N	69	NE5500N	43	INTERFACE	
74132N	69	NE5550V	43	PROM	65
74137N	69	NE556A	79	8088	8.00
74138N	87	NE556A	1.00	8057	3.95
74139N	87	LM549V	1.50	8059	6.95
74140N	87	NE567N	1.25	N825123	3.50
74147N	96	NE570N	9.00	8057	3.95
74148N	90	LM718	1.50	8059	6.95
74149N	1.15	78L05	6.00	8120	5.50
74192N	87	78L08	7.00	8123	3.10
74193N	87	78L05	7.00	8123	3.10
74221N	1.55	78M05	7.00	8123	3.10
74299N	1.65	75101	1.50	8126	2.75
74304N	86	79491Cn	5.00	8126	2.75
74368N	66	75492Cn	5.50	8127	2.75
74370N	66	75494Cn	8.99	8129	1.69
				8129	1.69

P.O. Box 4430E Santa Clara, CA 95054
For will call only: (408) 988-1640
2322 Walsh Ave.

QUEST ELECTRONICS

7400TL	1.15	LM337T	3.00	CD4583	3.50
7400N	17	LM337	3.00	CD4585	2.25
7400P	17	LM337	3.00	CD4585	4.50
7404N	19	LM339N	1.00	CD4583	4.50
7409N	23	LM381	1.50	CD40192	3.00
7410N	17	LM322	1.00	74C00	2.25
7414N	83	LM703H	42	74C00	2.25
7420N	17	LM709H	28	74C04	3.25
7422N	1.39	LM733N	2.00	74C10	2.25
7423N	20	LM733N	2.00	74C14	2.10
7424N	50	LM741Ch	37	74C20	2.25
7425N	69	LM741N	25	74C30	2.25
7427N	80	LM7479N	62	74C48	1.95
7428N	69	LM748N	35	74C76	1.40
7429N	17	LM753N	82	74C76	1.40
7474N	29	LM1304	1.10	74C90	1.15
7475N	49	LM1305	1.27	74C93	1.40
7485N	88	LM1307	2.00	74C154	3.00
7489N	2.00	LM1310	2.75	74C160	1.44
7490N	43	LM1458	1.75	74C175	1.35
7492N	43	LM1600	1.75	74C192	1.65
7493N	43	LM1812	1.75	74C221	2.00
7495N	69	LM1839	3.00	74C905	3.00
74100N	80	LM1181	7.50	74C906	3.00
74107N	29	LM2907	1.50	74C907	1.50
74117N	34	LM3909N	1.75	74C923	3.50
74120N	59	LM5455V	50	74C922	6.95
74125N	39	LM3909N	1.75	74C925	6.95
74130N	59	NE540L	2.89	74C927	6.95
74131N	69	NE5500N	43	INTERFACE	
74132N	69	NE5550V	43	PROM	65
74137N	69	NE556A	79	8088	8.00
74138N	87	NE556A	1.00	8057	3.95
74139N	87	LM549V	1.50	8059	6.95
74140N	87	NE567N	1.25	N825123	3.50
74147N	96	NE570N	9.00	8057	3.95
74148N	90	LM718	1.50	8059	6.95
74149N	1.15	78L05	6.00	8120	5.50
74192N	87	78L08	7.00	8123	3.10
74193N	87	78L05	7.00	8123	3.10
74221N	1.55	78M05	7.00	8126	2.75
74299N	1.65	75101	1.50	8126	2.75
74304N	86	79491Cn	5.00	8126	2.75
74368N	66	75492Cn	5.50	8127	2.75
74370N	66	75494Cn	8.99	8129	1.69
				8129	1.69

Multi-voltage Computer Power Supply
8v 5 amp. -18v 5 amp. 1.5 amp. -5v
5 amp. 12v 5 amp. -12 option. ±5v. ±12v
are regulated. Kit \$29.95. Kit with punched frame
\$34.95. Woodgrain case \$10.00.

Video Modulator Kit \$8.95
Convert your TV set into a high quality monitor
without affecting normal usage. Complete kit
with full instructions.

2.5 MHz Frequency Counter Kit \$37.50
Complete kit less case

30 MHz Frequency Counter Kit \$47.75
Complete kit less case
Prescaler kit to 350 MHz \$19.95

79 IC Update Master Manual \$35.00
Complete IC data selector. 2500 pg. master refer-
ence guide. Over 50,000 cross references. Free
update service through 1979. Domestic postage
\$3.50. Foreign \$5.00. 1978 IC Master closeout
\$19.50.

Stopwatch Kit \$26.95
Full six digit battery operated 2-.5 volts.
3.2768 MHz crystal accuracy. Times to 59
min., 59 sec., 99 1/100 sec. Times std., split
and Taylor. 7205 chip. all components minus
case. Full instructions.

Hickok 3 1/2 Digit LCD Multimeter
Batt/VAC oper. 0.1mv-1000v. 5 ranges. 0.5%
accur. Resistance 6 low power ranges. 0.1
ohm-20M ohm. DC cur. .01 to 100ma. Hand
held, 1/2" LCD displays, auto zero, polarity, over-
range. \$74.95.

S-100 Computer Boards
8K Static RAM KR \$135.00
16K Static RAM KR 265.00
24K Static RAM KR 423.00
32K Dynamic RAM Kit 310.00
64K Dynamic RAM Kit 470.00
8K/16K Eprom Kit (less PROMS) \$89.00
Video Interface Kit \$139.00
Motherboard \$39.00 Extender Board \$8.99

TERMS: \$5.00 min. order U.S. Funds. Calif residents add 6% tax.
BankAmericard and Master Charge accepted.
Shipping charges will be added on charge cards.

FREE: Send for your copy of our NEW 1979
QUEST CATALOG. Include 28¢ stamp.

THE MOST ADVANCED TIMEPIECE OF ITS KIND IN THE WORLD!

LCD Quartz Alarm Chronograph with calendar and dual time zone!! Watch is the same as Selko but you pay a lot more for the name!
Features:



- * 24 hour alarm
- * Chronograph counts up to 12 hrs., 59 mins. 59.9 sec.
- * Precision of chrono up to 1/10 sec indicated by 10 moving arrows!!
- * Lap time (with chrono running uninterrupted)
- * Time displays by LCD for hour, min, sec, day, date of the week and AM/PM
- * Calendar gives out date-day
- * Dual time zone for any two cities of the world at your own choice.
- * With light switch to allow you to see the time in the dark!

\$65.50

ONE YEAR FULL WARRANTY!

JUMBO 1" LED ALARM CLOCK MODULE

- Assembled - not a kit!
- Features:
- * 1" 4 digits red LED display
 - * 12 hours real time format
 - * 24 hours alarm audio output (just add speaker)
 - * Power failure indicator
 - * Count down timer 59 mins.
 - * 12-16V AC 50/60 Hz input
 - * 10 min. snooze control



\$8.50 EACH

P.C.M. 301

Transformer \$1.75

NEW MARK III 9 Steps 4 Colors LED VU



Stereo level indicator kit with arc-shape display panel!! This Mark III LED level indicator is a new design PC board with an arc-shape 4 colors LED display (change color from red, yellow, green and the peak output indicated by rose red). The power range is very large, from -30dB to +5dB. The Mark III indicator is applicable to 1 watt - 200 watts amplifier operating voltage is 3V - 9V DC at max 400 MA. The circuit uses 10 LEDs per channel. It is very easy to connect to the amplifier. Just hook up with the speaker output!

IN KIT FORM \$18.50

ELECTRONIC DUAL SPEAKER PROTECTOR

Cut off when circuit is shorted or overload to protect your amplifier as well as your speakers. A must for OCL circuits.
KIT FORM \$8.75 EA.



FM WIRELESS MIC KIT

It is not a pack of cigarettes. It is a new FM wireless mic kit! New design PC board fits into a plastic cigarette box (case included). Uses a condenser microphone to allow you to have a better response in sound pick-up. Transmits up to 350 ft.! With an LED indicator to signal the unit is on.



P.C.M. 2 KIT FORM \$7.95

GENERAL PURPOSE INSTRUMENT BOXES

All boxes are made of aluminum. Top is anodized black. Bottom is silver and comes with 4 rubber pedestals.



Part No.	Sizes	Price
FTA 421	4 1/8" (W) x 1 1/2" (H) x 2 7/8" (D)	\$2.10 ea.
FTA 452	4" (W) x 2" (H) x 5" (D)	3.50 ea.
FTA 572	5 3/8" (W) x 2 3/4" (H) x 7" (D)	4.95 ea.

DIGITAL AUTO SECURITY SYSTEM

4 DIGITS PERSONAL CODE!!



- proximity triggered
- voltage triggered
- mechanically triggered

3-WAY PROTECTION!

This alarm protects you and itself! Entering protected area will set it off, sounding your car horn or siren you add. Any change in voltage will also trigger the alarm into action. If cables within passenger compartment are cut, the unit protects itself by sounding the alarm.

SPECIAL \$19.95

ALL UNITS FACTORY ASSEMBLED AND TESTED—NOT A KIT!

TIMATRON RACK MOUNT TYPE CABINETS!



All are of aluminum and machine made to very high-precision quality with sleek, black anodized finish. Front panels come blank and undrilled to allow you to make panels of your own design. For large quantity orders Formula International will silkscreen print and drill panel holes at a minimal extra charge.

SIZE

19" (W) x 2 1/2" (H) x 12" (D)	\$36.85
19" (W) x 4" (H) x 12" (D)	45.25
19" (W) x 8" (H) x 20" (D)	72.00
16" (W) x 2 1/2" (H) x 8" (D)	26.50
16" (W) x 4" (H) x 8" (D)	33.45
9 1/2" (W) x 2 1/2" (H) x 12" (D)	33.45
9 1/2" (W) x 4" (H) x 12" (D)	24.50
9 1/2" (W) x 4" (H) x 8" (D)	30.25

PRICE

HICKOK LX303 DIGITAL LCD MULTIMETER

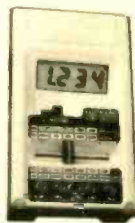

- 3 1/2 digits display
- 200 hours 9V battery life
- Auto zero; polarity; overrange indication
- 100MV DC F.S. sensitivity
- 19 ranges and functions
- D.C. volt: 0.1 MV to 1000 V
- A.C. volt: 0.1 V to 600 V
- Resistance: 0.1Ω to 20 MΩ
- D.C. current: 0.01 A to 100 MA

OUR PRICE \$71.45

60W + 60W



COMPLETED UNIT—NOT A KIT!

OCL pre amp. & power stereo amp. with bass, middle, treble 3-way tone control. Fully assembled and tested, ready to work. Total harmonic distortion less than 0.5% at full power. Output maximum is 60 watts per channel at 8Ω. Power supply is 24 - 36V AC or DC. Complete unit

Assembled \$49.50 ea.

Power transformer

\$ 8.50 ea.

22W + 22W STEREO HYBRID AMPLIFIER KIT

It Works in 12V D.C. As Well! Kit includes 1 PC SANYO STK-024 stereo power amp. IC LM 1458 as pre amp, all other electronic parts, PC Board, all control pots and special heat sink for hybrid. Power transformer not included. It produces ultra hi-fi output up to 44 watts (22 watts per channel) yet gives out less than 0.1% total harmonic distortion between 100Mz and 10KHz.

\$32.50 PER KIT

POWER TRANSFORMER \$6.50 EACH

GREEN COLOR 0.6" LED ALARM CLOCK



- 24 hr. alarm
- 10 min. snooze time
- AM/PM Indicator
- Power interrupt Indication
- Green color 0.6" display
- 110V AC 60Hz input
- Factory assembled.

NOT A KIT \$17.50 EACH

LCD CLOCK MODULE!



- 0.5" LCD 4 digits display
- X'tal controlled circuits
- D.C. powered (1.5V battery)
- 12 hr. or 24 hr. display
- 24 hr alarm set
- 60 min. countdown timer
- On board dual back up lights
- Dual time zone display
- Stop watch function

NIC1200 (12 hr) \$24.50 EA.
NIC2400 (24 hr) \$26.50 EA.

UNIVERSAL PROTOBOARDS "CIRCUIT FIT"

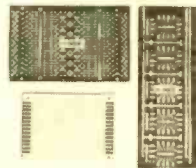
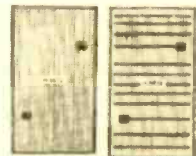

All Boards are made of High Quality G10 Fiber-glass and Phenolic, Pre-drilled in .042" diameter holes on 0.1" centers with tin plated copper eyelet and finger edge connectors (single sided) to allow any kind of standard components to fit board.

Part No.	Size	Holes	Price	
			Fiberglass	Phenolic
U.S.P 723	2" x 2.8"	529	\$ 1.27	\$.50
U.S.P 724	2.8" x 3.7"	750	2.42	.80
U.S.P 725	3.7" x 5.5"	1500	4.89	1.38
U.S.P 728	7" x 9.6"	6240	19.50	10.40
H-5612	3 1/2" x 6"			1.70
H-5616	3 1/2" x 6"			1.70
H-5606	3 1/2" x 5"			1.50
H-5602	2 1/2" x 6 1/2"			1.50

ELECTRONIC WHEEL OF FORTUNE KIT

With 10 numbers split into black and white on dial. The LED turns when you hit the play switch, then it slows down and stops on one number. It sounds like a motor inside, but there is none. Lots of fun and easy to build. Kit comes with nice looking case, all electronic parts, P.C. Board and LEDs. Battery not included.

\$12.50

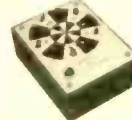

SUPER 15 WATT AUDIO AMP KIT



ONLY \$23.50 each

Uses STK-015 Hybrid Power Amp

Kit includes: STK-015 Hybrid IC, power supply with power transformer, front Amp with tone control, all electronic parts as well as PC Board. Less than 0.5% harmonic distortion at full power 1/2dB response from 20-100,000 Hz. This amplifier has QUASI-Complementary class B output. Output max is watt (10 watt RMS) at 4Ω.

MINI ELECTRONIC ORGAN KIT

PET-102 (25 KEYS)



The kit contains all electronic and mechanical parts, key boards, speaker, switches and PC Board as well as the wooden cabinet. Ideal for school project or gift to children interested in electronics. Uses 6V C size x 4 battery (not included). **\$38.50**

MANY SOUND DECISIONS!



\$3.60 EACH

Solid state sound indicator operating voltage 6V DC 30μA. Small size approximately 1/4" x 1 1/4".

Model EB2116 (Continuous)
Model EB2126 (Slow Pulse)
Model EB2136 (Fast Pulse)



Continuous



Slow Pulse



Fast Pulse

1Watt AUDIO AMP

All parts are pre assembled on a mini PC Board
Supply Voltage 6 ~ 9V D.C.
SPECIAL PRICE \$1.95 ea.



"FISHER" 30 WATT STEREO AMP

MAIN AMP (15W x 2)



Kit includes 2 pcs. Fisher PA 301 Hybrid IC all electronic parts with PC Board, power supply 2 16V DC. (not included). Power band with (KF 1% ± 3dB). Voltage gain 33dB. 20KHz - 20KHz.

Super Buy Only \$18.50

5W AUDIO AMP KIT

2 LM 380 with Volume Control
Power Supply 6 ~ 18V DC
ONLY \$6.00 EACH



TIMER KIT

Time Controlled for 1-100sec. Ideal to be used as timer delay unit for burglar alarm, photo service, and other purposes. Max. loading 110V, 2 AMP. Supply voltage 12-18V DC. **\$11.50 each**



FT-80 ELECTRONIC IC TIMER

ELECTRONIC ALARM SIREN

COMPLETE UNIT
Ideal for use as an Alarm Unit or hook-up to your car back up to make a reverse indicator. Light Output up to 130dB
Voltage Supply 6 ~ 12V **\$7.50**



AU-999

SOUND ACTIVATED SWITCH

All parts complete on a PC Board.
SCR with turn on relay. Uses 2 or 3 other circuit for 2 - 10Vn. (adjustable). Ideal for use as door alarm, sound controlled toys and many other projects.
Supply voltage 4.5V ~ 9V D.C.
\$1.75 ea./2 for \$3.00



LINEAR SLIDE POT

500KΩ SINGLE
Metal Case 3" Long
2 FOR \$1.20



Rechargeable
NI-CD Batteries Pak
6AA NI-CD In a flat pack gives you a total of 7.2V 450MA output
\$5.25 PER PACK



BATTERY POWERED FLUORESCENT LANTERN

FEATURES
• Circuitry designed for operation by high efficient, high power silicon transistor which enable illumination maintain in a standard level even the battery supply drops to a certain low voltage.
• 9" 6W cool/daylight miniature fluorescent tube.
• 8 x 1.5V UM 1 (size D) dry cell battery.
• Easy sliding door for changing batteries.
• Stainless reflector with wide angle in creating lumination of the lantern.



\$10.50 EACH
MODEL 888 R

PROFESSIONAL CASE



for our 0-30V Power Supply. It is a nice looking metal cast case with giant 4" volt/amp meter; output blinding post and fuse holder, on/off switch and line cord! **ONLY \$21.50 EA.**

CASE 030

POWER SUPPLY KIT



0-30V D.C. REGULATED
Uses UA723 and ZN3055 Power TR output can be adjusted from 0-30V, 2 AMP. Complete with PC board and all electronic parts.
\$10.50 each

Transformer for Power Supply, 2AMP 24V x 2 \$8.50

12V DC MINI RELAY

6V SPDT	2AMP	1.30
12V SPDT	3AMP	1.60
12V DPDT	2AMP	2.50
12V 4PDT	3AMP	3.50



ELECTRONIC SWITCH KIT



CONDENSER TYPE
Touch On Touch Off uses 7473 IC, and 12V relay.
\$5.50 each

ULTRA SONIC SWITCH KIT



Kit includes the Ultra Sonic Transducers, 2 PC Boards for transmitter and receiver. All electronic parts and instructions. Easy to build and a lot of uses such as remote control for TV, garage door, alarm system or counter. Unit operated by 9-12 DC. **\$15.50**

CDS LIGHT CONTROL SWITCH KIT

High Sensitivity Darlington Circuit, operated with a 9V D.C. supply to control lights or use it for burglar alarm, shooting game, visitor buzzer, product counting, flash-light slave unit or automatic door opener and many more. The potentiometer is to adjust the sensitivity and the relay in the circuit can handle up to 200 watts. **\$4.50 ea. kit**



TEXTTOOL 40 PINS D.I.P. ZERO INSERTION TEST SOCKET

It is perfectly suited for both hand test and burn in resistor meters. All brand new parts. \$8.75 ea.



I.C. TEST CLIPS

Same as the E 2 clips with 20 Long Leads in Black and Red Colors **\$2.75 per pair**



FM WIRELESS MIC KIT

This new model FM wireless MIC kit uses 3 high freq. transistors, works in the FM range (88-108 MHz). It transmits the sound wave fidelity clearly over long distances (up to 250 ft.). Kit comes with all electronic parts, P.C. Board and mini microphone!
\$6.95 EACH KIT

WE FOUND THE CASE FOR THE FM MIC!



Small nice looking aluminum case size like a pack of cigarettes. It is an intercom audio amp inside with a mic jack, a mini toggle sw on top, can be used for many projects. We give you the circuit data as well.
VERY SPECIAL PRICE 2 for \$4.99

Sub-Mini Size CONDENSER MICROPHONE

\$2.50 each
FET Transistor Built-In



FLUORESCENT LIGHT DRIVER KIT

12V DC POWERED
Lights up 8 ~ 15 Watt Fluorescent Light Tubes
Ideal for camper, outdoor Auto or Boat



Kit includes high voltage coil, power transistor, heat sink, all other electronic parts and PC Board, light tube not included!
WITH CASE ONLY \$6.50 PER KIT



5 AMP 5VDC

3 Terminals
Positive Voltage Regulator
Hard to find! Fairchild 78H05To-3 Package, Input 8.5 - 20V DC Output +5V DC 5AMP Load Regulation 1%.
Only \$8.75 ea

ECCO THUMBWHEEL SWITCHES

BCD OUTPUT 0-9
10 positions
3 digits with end and each digit section is detachable.
3 Digits only **\$5.00**



Sub Mini Size
PANEL METER
500 UA
ONLY \$1.20 ea

HARD TO FIND!! 12V 4PDT RELAY

3 Amp Contact
\$3.50 Each



TRANSFORMERS

ALL 117 VOLT INPUT

30V CT	4AMP	\$7.50 EA
36V CT	3AMP	\$8.50 EA
48V CT	3AMP	\$8.50 EA
24V CT	3AMP	\$8.50 EA
24V CT	0.8AMP	\$1.80 EA
12V CT	0.5AMP	\$1.80 EA
12V CT	120MA	\$1.25 EA

AC POWER SUPPLY

Watt Type Transformer

12V AC	Output	200MA	\$2.75 EA
15V CT AC	Output	100MA	\$2.10 EA
6V DC	Output	120MA	\$1.90 EA
12V DC	Output	100MA	\$1.90 EA

PROFESSIONAL PANEL METERS

A. 0-50UA	8.50 ea
B. 0-30VDC	8.50 ea
C. 0-50VDC	8.50 ea
D. 0-3ADC	9.00 ea
E. 0-100VDC	9.00 ea

Type MU-52E
All meters white face with black scales. Plastic cover.



HEAVY DUTY CLIP LEADS

10 pairs - 5 colors
Alligator clips on a 22" long lead. Ideal for any testing.
\$2.20/pack



MINI-SIZED I.C. AM RADIO

Size smaller than a box of matches!
Receives all AM stations
Batteries and ear phone included
Only \$10.50

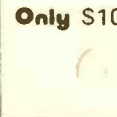

NUMERIC AND HEXADECIMAL LED DISPLAY WITH LOGIC

HP 5082 - 7300
• 4 x 7 Dot Matrix 0.4" Digit
• With On Board Decoder/Driver and Memory.
• TTL Compatible
• BCD Input
SPECIAL \$9.90 Each



GIANT SIZE VU METER

1MA movement 3 1/2" scale length. Scale in VU -20db to +3db. Meter face 5 1/8" x 2 3/8" with a "smoke" plastic cover.
SPECIAL \$8.50 Each



PUSH-BUTTON SWITCH

N/Open Contact
Color: Red, White, Blue, Green, Black. **3/\$1.00**
Available also 50c ea. **LARGE QTY. AVAILABLE**



SOLID STATE ELECTRONIC BUZZER

Mini size 1" x 3/8" high
Supply voltage 1.5V - 12V
Ideal for Alarm or Tone Indicator
\$1.50 each



MINIMUM ORDER \$10.00. California residents add 6% sales tax and 10% shipping. Out of state add 15% of total purchase for shipping charges, out of USA and Overseas add 25% of total purchase. **5/79**
SEND CHECK OR MONEY ORDER TO: **FORMULA INTERNATIONAL INC.**



FORMULA INTERNATIONAL INC.

12603 CRENSHAW BOULEVARD • HAWTHORNE, CALIFORNIA 90250

For more information please call (213) 973-1921, (213) 679-5162

STORE HOURS 10-7 Monday - Saturday

SEND \$1.00 FOR DETAILED CATALOG



SUBSCRIBE AND SAVE!



Get every exciting issue, every month, and save dollars, too.

News! New ideas! Excitement! It's happening every day in electronics, the most exciting, fastest-growing field in the world. So make sure you get every idea-packed issue of the world's best electronics magazine — Radio - Electronics. You get projects to build, test reports on new equipment, servicing tips, com-

puter technology, and more. You find all the news, all the features, and you find them first in Radio-Electronics. Plus, you get specialized columns in every issue: Computer Corner, Hi-Fi Lab Test Reports by Len Feldman, Jack Darr's Service Clinic, Hobby Corner, and the State-of-Solid-State, all written by experts, the outstanding authorities in the field.

Don't miss a single issue. Have Radio-Electronics delivered to your door, every month. Subscribe to Radio-Electronics today, and be assured of getting your

copy of each issue before it runs out on the newsstands. Save money too. When you choose one of the subscription offers listed on the coupon below you can save up to \$14.50 off the newsstand price of Radio-Electronics. You save time, you save money, and you get the most interesting, most exciting and authoritative reporting of electronics news you'll find in any magazine. Pick the plan you like best, and use the coupon right now to make sure you get all of the best—every issue of Radio-Electronics—every month.

Mail to: Radio-Electronics SUBSCRIPTION DEPT., P.O. BOX 2520, BOULDER, COLO. 80322

Save almost 1/2 off the newsstand. Indicate the offer you prefer:

- 1 Year—12 issues ONLY \$7.77**
(Save \$7.23 on newsstand or \$2.21 off basic subscription price.)
- 2 Years—24 issues ONLY \$15.50**
(Save \$14.50 on newsstand or \$3.50 off basic subscription price.)

(please print)

Name		
Address		
City	State	Zip Code

- Payment enclosed Bill me
- Check here if this is a new subscription.
- Check here if you are extending or renewing your subscription.

4059

Extra Shipping: Canada \$3.00 per year, all other countries \$5.00 per year.

Active Electronic Sales Corp.

Features.....

BRAND NEW!

JUST RELEASED
1979 IC MASTER
2500 pages



Complete integrated circuit data selector. Master guide to the latest I.C.'s including microprocessors and consumer circuits.

Free Quarterly Updates **\$39.95**

Texas Instruments Low Profile Sockets



Finest Quality Socket available in the world. Nobody can match Texas Instruments quality — a unique combination of I.C. technology and multi-metal expertise.

Over one million pieces in stock.

Contacts	Price	Contacts	Price
8 PIN	.08	22 PIN	.22
14 PIN	.12	24 PIN	.24
16 PIN	.14	28 PIN	.28
18 PIN	.18	40 PIN	.40
20 PIN	.20		



GENERAL INSTRUMENT

1 Amp Rectifiers (Epoxy)		1.5 Amp Single Phase Silicon Bridge Rectifiers	
Part No.	Price	Part No.	Price
1N4001	50V .029	W06M	600V .34
1N4002	100V .039	W08M	800V .39
1N4002	200V .045		
1N4004	400V .049		
1N4005	600V .055		
1N4006	800V .065		
1N4007	1000V .07		



SWITCHING DIODES

Part No	Price
1N914 (100V 4NS)	.027
1N4148 (100V 4NS)	.027

L.E.D. LAMPS

LED209	T-1 3mm Red	.09
LED211	T-1 3mm Green	.14
LED212	T-1 3mm Yellow	.13
LED220	T-1-3/4 5mm Red	.11
LED222	T-1-3/4 5mm Green	.15
LED224	T-1-3/4 5mm Yellow	.14

MAJOR MANUFACTURER



CMOS I.C.'S

CD4000BE 17	CD4042BE 59	CD4515BE \$1.95
CD4001BE 17	CD4043BE 57	CD4516BE 69
CD4002BE 17	CD4044BE 55	CD4518BE 79
CD4006BE 87	CD4046BE 99	CD4519BE 47
CD4007BE 17	CD4049BE 33	CD4520BE 69
CD4008BE 75	CD4050BE 33	CD4522BE 99
CD4009BE 39	CD4051BE 54	CD4526BE 99
CD4010BE 39	CD4052BE 54	CD4527BE \$1.09
CD4011BE 17	CD4053BE 99	CD4528BE 69
CD4012BE 17	CD4058BE 54	CD4531BE 74
CD4013BE 32	CD4066BE 44	CD4532BE \$1.19
CD4014BE 73	CD4068BE 21	CD4539BE 99
CD4015BE 69	CD4069BE 21	CD4543BE \$1.39
CD4016BE 35	CD4070BE 29	CD4555BE 65
CD4017BE 62	CD4071BE 21	CD4556BE 65
CD4018BE 69	CD4072BE 21	CD4581BE \$2.25
CD4019BE 39	CD4073BE 21	CD4582BE 79
CD4020BE 69	CD4075BE 25	CD4584BE 60
CD4021BE 69	CD4076BE 79	CD4585BE 90
CD4022BE 69	CD4077BE 29	40014PC 59
CD4023BE 17	CD4078BE 21	40085PC \$1.09
CD4024BE 49	CD4081BE 21	40097PC .60
CD4025BE 17	CD4082BE 21	40098PC .60
CD4026BE \$1.39	CD4085BE 69	40160PC .69
CD4027BE 39	CD4086BE 69	40161PC .99
CD4028BE 57	CD4093BE 40	40162PC .89
CD4029BE 74	CD4104BE \$2.25	40163PC .99
CD4030BE 35	CD4502BE 85	40174PC .89
CD4033BE \$1.45	CD4508BE \$2.25	40175PC .89
CD4034BE \$2.25	CD4510BE 88	40192PC \$1.19
CD4035BE 64	CD4511BE 99	40193PC \$1.19
CD4040BE 74	CD4512BE 59	40194PC \$1.10
CD4041BE 74	CD4514BE \$1.95	40195PC \$1.10

MICROPROCESSOR CHIPS CPU's

Part No.	Price
8080A	5.95 5.50
6800	8.95 7.95

INTERFACE SUPPORT CIRCUITS

Part No.	Price	Part No.	Price
8212	1.98	8255	5.95
8214	4.95 3.95	8257	9.95
8216	1.98	8259	14.95
8224	2.75		
8226	1.98	6810	3.95 3.50
8228	4.75	6820	4.95 3.95
8238	4.75	6821	4.95 3.95
8251	5.95 4.95	6850	5.95 4.95
8253	14.95	6852	5.95 4.95

MOS Static RAM's

Part No.	Price
2102LFPC	\$1.19
1K 350NS (Low Power)	
2102-1PC	\$9.99
1K 450NS	
2114	\$7.50
4K (1K x 4) 300NS	
2114	\$6.50
4K (1K x 4) 450NS	

MOS Dynamic RAM's

Part No.	Price
4K 4027	\$2.95
4K (4K x 1) 300NS 16 PIN	
416-3	\$9.95
200NS	
416-5	\$7.95
300NS	

UART's

Part No.	Price
AY5-1013A	\$4.95
AY3-1015	\$5.95

1K CMOS RAM

Part No.	Price
5101	\$4.95
450NS (Low Power)	
5101	\$3.95
800NS	



Z80-CTC	\$10.90
Z80A-CTC	\$13.10
Z80-DMA	46.00 \$32.20
Z80-CPU	19.95 \$13.60
Z80A-CPU	23.95 \$16.20
Z80-SIO/0	59.00 \$45.00
Z80A-SIO/0	69.00 \$50.00
Z80-SIO/1	59.00 \$45.00
Z80A-SIO/1	69.00 \$50.00
Z80-PIO	\$10.90
Z80A-PIO	\$13.10

LINEAR I.C.'S

LM324N	49	Quad Op Amp
LM339N	49	Quad Comparator
LM555N-8	29	Timer
LM556N-14	59	Dual Timer
LM723CN	34	Voltage Regulator
LM723CH	39	Voltage Regulator
LM741CH	37	Op Amp
LM741CN-8	24	Op Amp
LM1458N-8	39	Dual Op Amp

VOLTAGE REGULATORS

PART NO.	UNIT PRICE	DESCRIPTION
LM323K	\$3.50 \$4.95	3 Amp 5 Volt Regulator
78H05KC	\$5.75	5 Amp 5 Volt Positive Regulator TO3
7800UC Series TO-220/LM340T	.79	Positive Voltage Regulators (Plastic) 1 Amp 5.6, 8, 12, 15, 18, 24 Volts
78MO0HC Series TO-5/LM340H	\$1.50	Positive Voltage Regulator 1/2 Amp 5.6, 8, 12, 15, 18, 24 Volts
7800KC Series TO-3/LM340K	\$1.60	Positive Voltage Regulator 1 Amp 5, 6, 8, 12, 15, 18, 24 Volts
78L00AWC Series TO-92	.29	Positive Voltage Regulator 100 MA 2.6, 5, 6.2, 8.2, 12, 15 Volts
7900UC Series TO-220/LM320T	\$1.10	Negative Voltage Regulator 1 Amp 5, 6, 8, 12, 15, 18, 24 Volts
79MO0HC Series TO-5/LM320H	\$1.50	Negative Voltage Regulator 1/2 Amp 5, 6, 8, 12, 15, 20, 24 Volts
7900KC Series TO-3/LM320K	\$1.95	Negative Voltage Regulator 1 Amp 5, 6, 8, 12, 15, 18, 24 Volts
78MGT2C	\$1.25	Dual In Line Adjustable 4 Terminal Positive Voltage Regulator
78GUI TO-220	\$1.45	1 Amp Adjustable Positive Voltage Regulator
78S4OPC	\$2.50	Switching Regulator

All new major manufacturer production material offered. Largest variety of device types available anywhere.

Active Electronic Sales Corp.

P.O. BOX 1035 FRAMINGHAM, MASSACHUSETTS 01701

Over-the-counter sales,
12 Mercer Rd., Natick, Mass 01760
Behind Zayres on Rte. 9
Telephone Orders & Enquiries (617)879-0077

IN CANADA 3 LOCATIONS

5651 FERRIER ST.
MONTREAL, QUEBEC
H4P 2K5
Tel: (514) 735-6425

4800 DUFFERIN ST.
DOWNSVIEW, ONTARIO
M3H 5S9
Tel: (416) 668-1115

MINIMUM ORDER \$10.00 • ADD \$2.00 TO COVER POSTAGE & HANDLING

Foreign customers please remit payment on an international bank draft or international postal money order in American dollars.

BAXTER CENTRE
1050 BAXTER ROAD
OTTAWA, ONTARIO
K2C 3P2
Tel: (613) 820-9471



KITS • KITS • KITS

NEW . . . PRE-DRILLED PCB'S FOR ALL 100 SERIES KITS

Perforated Boards NOT INCLUDED w/100 Series



103 MINI-WINK NEDN FLASHER. Random flash pattern. Interesting displays. 6 neon lamps. AC operated.

103 \$2.95
103A (103 w/PCB) 4.60
103B (103 w/PCB,CASE) 6.85



110 ELECTRONIC WHOOPER SIREN. Powerful wailing sound. Dual oscillator circuit. Use with any alarm circuit. Battery not included.

110 \$4.95
110A (110 w/PCB) 6.50
110B (110 w/PCB,CASE) 9.60



117 TUNABLE ELECTRONIC ORGAN. Tunable 7-note scale. Play sing-a-long favorites. Battery not included.

117 \$6.95
117A (117 w/PCB) 8.90
117B (117 w/PCB,CASE) 12.00



120 SIREN/CODE OSCILLATOR. Loud, piercing alarm. Practice Morse code. Battery not included.

120 \$4.20
120A (120 w/PCB) 5.55
120B (120 w/PCB,CASE) 8.65



104 VARIABLE STROBE LIGHT. Great for parties and photography. Variable flash rate. AC operated.

104 \$9.95
104A (104 w/PCB) 14.20
104B (104 w/PCB,CASE) 19.70



126 PROGRAMMABLE DOORBELL. Adjustable rate and pitch for 15 musical notes. Play favorite tunes. 6 IC's. Uses existing transformer and switch.

126 \$16.95
126A (126 w/PCB) 23.70
126B (126 w/PCB,CASE) 29.20

Perforated Boards NOT INCLUDED w/100 Series

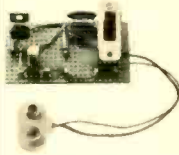

109 AUTO/HOME BURGLAR ALARM. Use with car horn or models 110 or 124 sirens. Latching circuit. Battery not included.

109 \$2.25
109A (109 w/PCB) 3.40
109B (109 w/PCB,CASE) 5.00

114 AUDIO AMPLIFIER. High sensitivity, high gain, use as intercom, PA amp, phone pick-up and others, push-pull output. Battery not included.

114 \$6.35
114A (114 w/PCB) 8.90
114B (114 w/PCB,CASE) 12.00



102 6/9 VOLT SUPPLY. 100mA. Battery eliminator, dual range output switch, neon pilot lamp. AC operated.

102 \$3.95
102A (102 w/PCB) 5.30
102B (102 w/PCB,CASE) 7.25

119 MOTOR SPEED CONTROL. Adjust motor speed to suit application. SCR controlled, use as light dimmer. AC operated.

119 \$3.95
119A (119 w/PCB) 5.50
119B (119 w/PCB,CASE) 7.75



123 ELECTRONIC TIMER. Turns appliances on and off, adjustable control, 2 minutes to 1 hour. 1 IC, AC operated.

123 \$8.95
123A (123 w/PCB) 11.40
123B (123 w/PCB,CASE) 13.65

540 BINARY CLOCK. Handcraft tomorrow's timepiece today. Watch constantly changing patterns of LED's as they display Binary Time. This unique clock project enhances the learning of Digital Logic and the Binary Coding System, as well as offering a beautifully styled conversation piece.

10 TTL INTEGRATED CIRCUITS • VOLTAGE REGULATOR • 43,000 PULSATING LIGHT PATTERNS • FAST, SLOW AND HOLD CONTROLS • 115VAC 50 or 60Hz.



\$39.95 Complete with 80 page manual

536 8-TRANSISTOR AM RADIO. Experience jewel-like clarity in sound. The best superheterodyne kit circuit available. SEPARATE LOCAL OSCILLATOR for high sensitivity and excellent selectivity. Unique IF Transformer mounting system. 9V battery required (not included).



\$16.45 Complete with 88 page manual

Perforated Boards NOT INCLUDED w/100 Series



124 WARBLING SIREN. Two-tone oscillating siren. Loud and penetrating, 2 IC's. For automobile or other 12 volt systems.

124 \$5.65
124A (124 w/PCB) 7.10
124B (124 w/PCB,CASE) 10.20



105 FISH CALLER. Clicking sound imitates distressed fish. Adjustable speed. Battery not included.

105 \$2.95
105A (105 w/PCB) 4.10
105B (105 w/PCB,CASE) 5.70



107 COLOR ORGAN CONTROL — 3 CHANNEL. Over 200W per channel. Separate sensitivity control. Hi-mid-lo frequency response. AC operated.

107 \$9.20
107A (107 w/PCB) 11.85
107B (107 w/PCB,CASE) 14.95



118 TV SCRAMBLER. Tunable to all VHF stations. 30 foot range. Battery not included.

118 \$1.95
118A (118 w/PCB) 2.90
118B (118 w/PCB,CASE) 4.50



122 COMPUTER SOUND EFFECTS GENERATOR. Produces weird, spacey sounds. 4 IC's. Control tone, rate and blip or glide. Battery not included.

122 \$14.95
122A (122 w/PCB) 19.40
122B (122 w/PCB,CASE) 24.90

We accept:

VISA,



MASTER CHARGE BANK AMERICARD,

Write to us for
New Product Info

DO NOT SEND CASH • NO COD • ORDER BY PHONE OR MAIL

CALIF. RESIDENTS ADD 6% SALES TAX.

MINIMUM ORDER \$10.00

WE PAY POSTAGE AND HANDLING

IN U.S.A. OVERSEAS COUNTRIES:

ADD 15% OF TOTAL FOR POSTAGE.

SEND CHECK OR
MONEY ORDER TO:

Graymark

International, Inc.

1751 McGaw Avenue Dept. 5 Irvine, CA 92714 (714) 540-5480

MICRO MART

552 Summit Ave.
Westfield, N.J. 07090
(201) 654-6008

7403	.12	74H53	.20
74H04	.20	7474	.25
7427	.18	7482	.50
7429	.29	7492	.35
7432	.20	74145	.40
7437	.20	74151	.50
7438	.15	74180	.50
74H38	.20	74193	.60
7439	.25	8235	.50
7442	.30	8266	.50
7445	.50	8563	.50
7447	.35	8815	.25
7451	.16	75324	.75

ICM 7107 DMM chip	\$15.00
MM 5369	\$2.95
11C90 Prescaler chip	\$16.00

Radio-TV Communications
LINEAR IC's

ECG Replacement Series

ECG 708/1.00	ECG 741/1.00
ECG 709/1.90	ECG 742/1.70
ECG 712/1.90	ECG 743/1.50
ECG 713/1.25	ECG 780/1.50
ECG 714/1.05	ECG 783/1.15
ECG 715/1.05	ECG 788/1.50
ECG 721/1.30	ECG 790/1.95
ECG 722/1.00	ECG 791/1.50
ECG 723/1.80	ECG 801/1.50
ECG 731/1.50	ECG 804/1.85
ECG 732/1.75	ECG 807/1.25
ECG 736/1.50	ECG 815/1.00
ECG 737/1.30	ECG 818/1.55
ECG 738/1.70	ECG 982/1.55
ECG 739/1.70	ECG 1061/2.00
ECG 740/1.30	ECG 1062/2.00

DEALER DISCOUNT-15%-25 orders this category

★ LM 377 — LM 380
MONTHLY SPECIAL
2/2.00 5/4.00 ★

DARLINGTON ARRAYS

ULN 2001	ULN2003
ULN 2002	ULN2004

\$1.75 each any 4 for \$5.00

Voltage Regulators

7805, 7805T, 7812T, 7905T, 7912T	\$1.25 each
----------------------------------	-------	-------------

Terms: MICRO-MART accepts Visa, MC, and telephone COD'S. Foreign orders \$50.00 minimum plus shipping-US funds only. Orders under \$10.00 include \$2.00 for shipping/handling. All components guaranteed or money refunded. Immediate shipping. N.J. residents add 5% sales tax.

MICRO-MART • 552 SUMMIT AVE., WESTFIELD, N.J. 07090 • (201) 654-6008

MOTION DETECTORS
(specs included)
\$3.00
3 1/2" x 2 x 1 1/4" case with mtng. tabs/\$2.00

RESISTOR ASSORTMENT
includes 1/4W pre-formed leads
20 popular values, 1000 pcs./\$5.00

CAPACITOR ASSORTMENT
wide range of ceramics, 500 pcs./\$5.00

OPERATIONAL AMPLIFIERS
UA 741's — \$2.25

DISPLAYS
Jumbo Reds — 10/51.00, 100/\$9.00
25 pack, assorted — \$3.00
5", 7 seg. FND 500,501,503,507,510 — \$1.00 each

BRIDGES
1 1/2Amp/.50, 6Amp/\$2.00, 25Amp/\$1.50

IC SOCKETS
8 pin/.15, 14 pin/.16, 16 pin/.18, 18 pin/.25,
24 pin/.35, 28 pin/.40, 40 pin/.50

MOLEX PINS (7 pin/strip)
500 for \$4.00
1,000 for \$6.00

REED SWITCH
1/2", 10/\$1.00

IN 4001's (Comp. Grade), 15/\$1.00

CONDENSER MIKE — \$1.50

TO-5 Case TRANSISTOR SOCKETS, 5/\$1.00

9V RADIO BATTERIES, 5/\$3.00

6.3V, 1.2 Amp Transformer — \$1.25

Self Adhesive Rubber Bumpers — 25 for \$1.00

AUDIO CABLE: #24, 2 conductor \$1.00/100 ft.

HARDWARE
4-40x 1/4, 1/2 screws-1,000 pcs. ass't/\$3.50
6-32x 1/4, 1/2 screws-1,000 pcs. ass't/\$4.00

ELECTROLYTICS
100 of 10V/.25, 470 of 10V/.25, 3200 of 25V/.50

7400 TTL	.16
7404	.10
7405	.19
7410	.18
7412	.25
7413	.40
7416	.25
7420	.20
7425	.28
7426	.28
7427	.25
7430	.20
7437	.24
7438	.24
7440	.20
7445	.75
7451	.20
7454	.20
7474	.35
7475	.49
7483	.58
7485	.78
7486	.35
7489	1.80
7490	.43
7492	.42
7493	.42
7495	.65
74107	.35
74123	.49
74141	.78
74151	.58
74155	.75
74160	.86
74165	.86
74175	.75
74190	.75
74181	1.85
74195	.65

MISC TTL	.35
74805	.35
74850	.35
74853	1.95
748181	2.75

P1103A
1024 X 1 Dynamic
RAM
42c

700ns
\$6.25

2708
1024 X 8 EPROM
250ns \$8.50

74S201
256 X 1 Static RAM
\$1.95 50ns

ULN2001
High-current Drivers.
Darlingtons 75c

MC1458P
Dual Op-Amp
24c

555
TIMER
28c

8038C
VCO Waveform Gen.
w/sine 99c

82S115
512 X 8 PROM 60ns
\$4.75

LINEAR	
LM300H	.78
LM301N	.35
LM305H	.60
LM306H/N	1.50
LM307H/N	.35
LM308	.95
LM309K	1.25
LM310H	1.10
LM311H	.85
LM320T5	1.25
LM320T12	1.25
LM320T15	1.25
LM322H	1.75
LM323K	5.75
LM340T5	1.25
LM340T12	1.25
LM340T15	1.25
LM556	1.65
LM711H/N	.39
LM713H	.55
LM725H	1.75
LM733H	.95
LM741H/N	.35
LM747H	.78
LM749H	.85
LM790N	.46
78H05	6.95
SG4501	1.95

TRANSISTORS	
2N2222A	5/1.00
2N2907T	5/1.00
2N3055	.85
2N3904	5/1.00
2N3906	5/1.00
2N4011	5/1.00
2N4403	5/1.00
1N782955	1.20
1N783055	1.00

DIODES	
1N914	15/1.00
1N4003	12/1.00
1N4009	10/1.00
1N4007	10/1.00
1N4148	15/1.00

COMPUTER COMPONENTS

1973 South State College - Anaheim, Calif. 92806

Visa - MasterCard
Check or M.O.
No COD

(714) 937-0641

Minimum Order-10.00
Add 1.00 for Frt.
Cal. Res. add 6%

CIRCLE 33 ON FREE INFORMATION CARD

CIRCLE 71 ON FREE INFORMATION CARD

YOUR ATTENTION PLEASE!

ANNOUNCING OUR SPRING SALE

with big \$\$ savings for you on **BK PRECISION** equipment

Reg. \$655.00 Our Price \$555.95
Dual-Trace 10 MHz Triggered 5" Scope

MODEL

1471B

- 18 calibrated sweeps—1 μ SEC/cm to 55SEC/cm
- Sweep to 200nSEC/cm with 5X magnification
- Front panel X-Y operation
- Check most digital logic circuitry.
- Includes probes



MODEL

1403A

- For production lines, schools, field service work, hobbyists
- Ultra-compact and lightweight; goes anywhere!
- Vertical sensitivity of 10mV/division.
- Z-axis input for intensity modulation

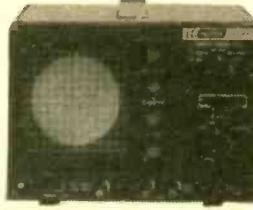

MODEL

1474

- Triggers on signals up to 50 MHz
- 5mV/cm vertical sensitivity
- Checks most digital logic circuitry.
- Built-in high- and low-pass filters
- 20 calibrated sweeps — 0.2 μ S/cm — 0.5 S/cm
- Algebraic addition and subtraction
- Probes included



Reg. \$99.95 Our Price \$85.00
3-1/2 Digit Portable DMM

- fully overload protected
- High-/Low-power ohms for in-circuit accuracy
- Auto zeroing
- DC accuracy 1% typical



MODEL 2800

Reg. \$185 Our Price \$156.95
Industrial Transistor Tester
with HI/LO Drive

- Works in-circuit
- Identifies all three transistor leads
- Automatic NPN/PNP determination
- Tests diodes, SCR's, FET's, and Darlingtons



MODEL 520B

Reg. \$130 Our Price \$109.95
Portable Digital Capacitance Meter

- Measures from 0.1pF to 1 Farad
- 10 ranges for accuracy and resolution
- 4 digit LED display
- 0.5% accuracy

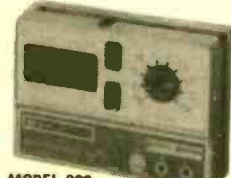

MODEL 820

Reg. \$185 Our Price \$156.50
3-1/2 Digit Lab Multimeter

- Selectable HI/LO ohms function
- Large, 7-segment digits
- DC accuracy, 0.5%
- Automatic polarity
- Full overload protection
- 100% overrange
- Test leads supplied



MODEL 283

Reg. \$480 Our Price \$405.95
5 Hz-520 MHz Frequency Counter

- Gate time from 10ns to 10 seconds
- Full period measurement capability
- 50 mV input sensitivity at 520MHz
- (TCXD)



MODEL 1850

ED LIEBLING & CO, INC., 1673 Chapin Ave., N. Merrick, New York 11566

We invite you to Call or Write for Discount Prices on Hickock, Leader, Eico, and NLS.

Call toll free 800-645-4727

Ask for Larry or Ed for Super Discounts

N.Y. State call (516) 735-3331

VISA MASTERCHARGE ACCEPTED

CIRCLE 41 ON FREE INFORMATION CARD

REGULATED POWER SUPPLIES			
POWER SYSTEMS # PS1111			
115-230V 50/60 cy. in 5v DC at 35A out.			
6" x 16" x 15" 26 lbs. shipping weight \$55.00			
POWER SYSTEMS # PS1106			
115-230V 50/60 cy. in 12v DC at 15A out.			
5" x 16" x 5" 19 lbs. shipping weight \$49.00 (OV PROTECT)			
C/MOS (DIODE CLAMPED)			
4001	-18	4019	37 4050
4002	-18	4020	90 4055
4006	-95	4021	90 4055
4007	-18	4022	90 4066
4009	37	4023	-18 4066
4010	-37	4024	75 4071
4011	-18	4025	-18 4072
4012	-18	4027	-37 4076
4013	-29	4028	80 4570
4014	-75	4029	-95 74C08
4015	75	4030	-97 74C08
4016	-29	4035	-97 74C08
4017	-105	4042	-55 74C10
4018	90	4049	35 74C13
1488	RS322	INTERFACE	\$1.50
1489	RS232	INTERFACE	\$1.25
2000	7M	STATE STAT SW	\$1.50
2513	CHARAC	GEN UP	8.75
2518	RS232	SHIF REG	2.20
2522	STAT	SHIF REG	1.90
2708A	EPROM	40K	12.95
2716	300K	80K	13.50
2718	1T	1024	9.75
2720	1T	1024	9.95
2722	1T	1024	9.95
2724	1T	1024	9.95
2726	1T	1024	9.95
2728	1T	1024	9.95
2730	1T	1024	9.95
2732	1T	1024	9.95
2734	1T	1024	9.95
2736	1T	1024	9.95
2738	1T	1024	9.95
2740	1T	1024	9.95
2742	1T	1024	9.95
2744	1T	1024	9.95
2746	1T	1024	9.95
2748	1T	1024	9.95
2750	1T	1024	9.95
2752	1T	1024	9.95
2754	1T	1024	9.95
2756	1T	1024	9.95
2758	1T	1024	9.95
2760	1T	1024	9.95
2762	1T	1024	9.95
2764	1T	1024	9.95
2766	1T	1024	9.95
2768	1T	1024	9.95
2770	1T	1024	9.95
2772	1T	1024	9.95
2774	1T	1024	9.95
2776	1T	1024	9.95
2778	1T	1024	9.95
2780	1T	1024	9.95
2782	1T	1024	9.95
2784	1T	1024	9.95
2786	1T	1024	9.95
2788	1T	1024	9.95
2790	1T	1024	9.95
2792	1T	1024	9.95
2794	1T	1024	9.95
2796	1T	1024	9.95
2798	1T	1024	9.95
2800	1T	1024	9.95
2802	1T	1024	9.95
2804	1T	1024	9.95
2806	1T	1024	9.95
2808	1T	1024	9.95
2810	1T	1024	9.95
2812	1T	1024	9.95
2814	1T	1024	9.95
2816	1T	1024	9.95
2818	1T	1024	9.95
2820	1T	1024	9.95
2822	1T	1024	9.95
2824	1T	1024	9.95
2826	1T	1024	9.95
2828	1T	1024	9.95
2830	1T	1024	9.95
2832	1T	1024	9.95
2834	1T	1024	9.95
2836	1T	1024	9.95
2838	1T	1024	9.95
2840	1T	1024	9.95
2842	1T	1024	9.95
2844	1T	1024	9.95
2846	1T	1024	9.95
2848	1T	1024	9.95
2850	1T	1024	9.95
2852	1T	1024	9.95
2854	1T	1024	9.95
2856	1T	1024	9.95
2858	1T	1024	9.95
2860	1T	1024	9.95
2862	1T	1024	9.95
2864	1T	1024	9.95
2866	1T	1024	9.95
2868	1T	1024	9.95
2870	1T	1024	9.95
2872	1T	1024	9.95
2874	1T	1024	9.95
2876	1T	1024	9.95
2878	1T	1024	9.95
2880	1T	1024	9.95
2882	1T	1024	9.95
2884	1T	1024	9.95
2886	1T	1024	9.95
2888	1T	1024	9.95
2890	1T	1024	9.95
2892	1T	1024	9.95
2894	1T	1024	9.95
2896	1T	1024	9.95
2898	1T	1024	9.95
2900	1T	1024	9.95
2902	1T	1024	9.95
2904	1T	1024	9.95
2906	1T	1024	9.95
2908	1T	1024	9.95
2910	1T	1024	9.95
2912	1T	1024	9.95
2914	1T	1024	9.95
2916	1T	1024	9.95
2918	1T	1024	9.95
2920	1T	1024	9.95
2922	1T	1024	9.95
2924	1T	1024	9.95
2926	1T	1024	9.95
2928	1T	1024	9.95
2930	1T	1024	9.95
2932	1T	1024	9.95
2934	1T	1024	9.95
2936	1T	1024	9.95
2938	1T	1024	9.95
2940	1T	1024	9.95
2942	1T	1024	9.95
2944	1T	1024	9.95
2946	1T	1024	9.95
2948	1T	1024	9.95
2950	1T	1024	9.95
2952	1T	1024	9.95
2954	1T	1024	9.95
2956	1T	1024	9.95
2958	1T	1024	9.95
2960	1T	1024	9.95
2962	1T	1024	9.95
2964	1T	1024	9.95
2966	1T	1024	9.95
2968	1T	1024	9.95
2970	1T	1024	9.95
2972	1T	1024	9.95
2974	1T	1024	9.95
2976	1T	1024	9.95
2978	1T	1024	9.95
2980	1T	1024	9.95
2982	1T	1024	9.95
2984	1T	1024	9.95
2986	1T	1024	9.95
2988	1T	1024	9.95
2990	1T	1024	9.95
2992	1T	1024	9.95
2994	1T	1024	9.95
2996	1T	1024	9.95
2998	1T	1024	9.95
3000	1T	1024	9.95
3002	1T	1024	9.95
3004	1T	1024	9.95
3006	1T	1024	9.95
3008	1T	1024	9.95
3010	1T	1024	9.95
3012	1T	1024	9.95
3014	1T	1024	9.95
3016	1T	1024	9.95
3018	1T	1024	9.95
3020	1T	1024	9.95
3022	1T	1024	9.95
3024	1T	1024	9.95
3026	1T	1024	9.95
3028	1T	1024	9.95
3030	1T	1024	9.95
3032	1T	1024	9.95
3034	1T	1024	9.95
3036	1T	1024	9.95
3038	1T	1024	9.95
3040	1T	1024	9.95
3042	1T	1024	9.95
3044	1T	1024	9.95
3046	1T	1024	9.95
3048	1T	1024	9.95
3050	1T	1024	9.95
3052	1T	1024	9.95
3054	1T	1024	9.95
3056	1T	1024	9.95
3058	1T	1024	9.95
3060	1T	1024	9.95
3062	1T	1024	9.95
3064	1T	1024	9.95
3066	1T	1024	9.95
3068	1T	1024	9.95
3070	1T	1024	9.95
3072	1T	1024	9.95
3074	1T	1024	9.95
3076	1T	1024	9.95
3078	1T	1024	9.95
3080	1T	1024	9.95
3082	1T	1024	9.95
3084	1T	1024	9.95
3086	1T	1024	9.95
3088	1T	1024	9.95
3090	1T	1024	9.95
3092	1T	1024	9.95
3094	1T	1024	9.95
3096	1T	1024	9.95
3098	1T	1024	9.95
3100	1T	1024	9.95
3102	1T	1024	9.95
3104	1T	1024	9.95
3106	1T	1024	9.95
3108	1T	1024	9.95
3110	1T	1024	9.95
3112	1T	1024	9.95
3114	1T	1024	9.95
3116	1T	1024	9.95
3118	1T	1024	9.95
3120	1T	1024	9.95
3122	1T	1024	9.95
3124	1T	1024	9.95
3126	1T	1024	9.95
3128	1T	1024	9.95
3130	1T	1024	9.95
3132	1T	1024	9.95
3134	1T	1024	9.95
3136	1T	1024	9.95
3138	1T	1024	9.95
3140	1T	1024	9.95
3142	1T	1024	9.95
3144	1T	1024	9.95
3146	1T	1024	9.95
3148	1T	1024	9.95
3150	1T	1024	9.95
3152	1T	1024	9.95
3154	1T	1024	9.95
3156	1T	1024	9.95
3158	1T	1024	9.95
3160	1T	1024	9.95
3162	1T	1024	9.95
3164	1T	1024	9.95
3166	1T	1024	9.95
3168	1T	1024	9.95
3170	1T	1024	9.95
3172	1T	1024	9.95
3174	1T	1024	9.95
3176	1T	1024	9.95
3178	1T	1024	9.95
3180	1T	1024	9.95
3182	1T	1024	9.95
3184	1T	1024	9.95
3186	1T	1024	9.95
3188	1T	1024	9.95
3190	1T	1024	9.95
3192	1T	1024	9.95
3194	1T	1024	9.95
3196	1T	1024	9.95
3198	1T	1024	9.95
3200	1T	1024	9.95
3202	1T	1024	9.95
3204	1T	1024	9.95
3206	1T	1024	9.95
3208			

SEND FOR YOUR FREE TEK-EL CATALOG
 Complete Listings of IC Transistors, Capacitors, Resistors and readouts along with migration closeouts and surplus material.
 • Hobbyist • Experimenter • Scientist • Wholesale & Dealer Inquiries invited.

MOTION DETECTING OPTOLINEAR I.C.



Fantastic new development in I²L I.C. technology! This is a 14 pin device mounted on a P.C. board with all the necessary capacitors and lens for a fully functioning motion detector. Requires a 3.5 VDC supply a speaker and two switches. The device is capable of detecting movement for a minimum dist. of 8 ft. and sounds whooper alarm and/or flash lite if you add a bulb to circuit. The detector works on a change of ambient light of +5% or more triggers the detector. Works within a range of 0.1 cp to 100 cp. NO external light source is needed. Complete with data sheets. See Elementary Electronics March/April 1979 on the Cyclops pg. 37
 Cat. No. K1137 Wt. 2 oz. 2 for \$25

COD'S MAY BE PHONED!
 TERMS: Add Postage
 RATED: Net 30 **\$14.95**
 PHONE: (617) 631-7434 9:00 A.M. to 4:30 P.M.
 MINIMUM ORDER: \$10

When ordering, always use catalog number, type no., the name of the magazine you are ordering from and the month.

TEK-EL Corp.
 P.O. Box 761
 Marblehead, Mass.
 01945

CIRCLE 35 ON FREE INFORMATION CARD

SATELLITE TV
GET 50 CHANNELS!

It's all true! No matter where you live receive movies, sports, pay television, sports from around the world! 24-hour programming! Crystal clear reception! For complete information, sources and design information, send \$7.95.

SPACECOAST RESEARCH
 Dept. B, P.O. Box 442, Altamonte Springs, FL 32701



New Technology!

RADIO-ELECTRONICS

Don't be a heart breaker

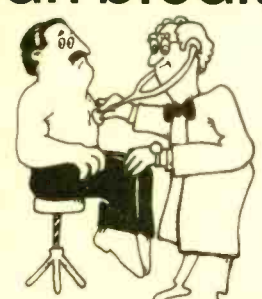

Have regular medical check-ups.

The American Heart Association
 WE'RE FIGHTING FOR YOUR LIFE

ADVERTISING INDEX

RADIO-ELECTRONICS does not assume any responsibility for errors that may appear in the Index below.

Free Information Number	Page
5	Aaron-Gavin Instruments..... 92
4	Active Electronics..... 121
—	Advance Computer..... 76, 82-83, 95
29	Advanced Computer Products..... 127
—	A M C Sales..... 107
45	Amelect, Inc..... 81
3	American Antenna..... Cov. 4
47	Ampower..... 128
2	A P Products, Inc..... Cov. 3
43	B & K Precision Dynascan Co..... 100
60	Babylon Electronics..... 116
—	Karel Barta..... 108
74	Blonder Tongue..... 33
—	Bullet Electronics..... 110
—	Burdex Security Co..... 107
49	C F R Associates..... 126
—	Chaney Electronics..... 116
17	Channellock..... 74
—	C I E—Cleveland Institute of Electronics..... 18-21
—	Command Productions..... 108
71	Computer Components..... 124
6 & 36	Continental Specialties..... Cov. 2 & 25
—	Dage Scientific Instruments..... 108
7	Delta Electronics..... 108
57	Diamondback Electronics..... 114
63	Digi-Key..... 123
—	Digital Research Corporation..... 114
41	Edlie Electronics..... 124
—	Edmund Scientific..... 81
30	Electronic Book Club (Tab Books)..... 23
—	Electronics & Control Engineer's Book Club—McGraw Hill Book Div..... 88-91
—	Electronic Development Lab..... 107
8	Electronic Devices..... 79
—	E M C—Electronic Measurements..... 26
38	Electronic Supermarket..... 110
73	Electronic Systems..... 115
61, 72, 75	Fluke..... 78, 105
68	Fordham Radio Supply..... 109
—	Forest Belt's Training Workshop..... 97
9 & 10	Formula International..... 118 & 119
—	Fuji-Svea..... 111
—	G E—General Electric..... 15
53	Godbout Electronics..... 116
12	Gould..... 16
31	Grantham College of Engineering..... 106
11	Graymark..... 122
100	Heath..... 12-13
100	Heath..... 28-31
—	Heath..... 99 & 101
48	Hickok Electrical Instruments..... 7
64	Hobby World..... 128
—	Information Unlimited..... 107
—	Institute of High-Fidelity, Inc..... 77
44	International Crystal Mfg. Co..... 79
13 & 14	Jameco Electronics..... 112 & 113
32	Jan Crystal..... 126
15	Kester Solder..... 24
—	Lakeside Industries..... 107
56	Leader..... 22
65	McKay Dymek..... 116
37	Meshna..... 110
33	Micro Mart..... 124

—	Milleco Industries..... 108
39	Mobile Training Institute..... 104
16	National Camera Supply..... 106
—	National Radio Institute (NRI) Div. of McGraw Hill..... 8-11
—	National Technical Schools..... 70-73
—	NESDA..... 26
51	Netronics..... 32
18	Ohio Scientific..... 1
42	O. K. Machine & Tool..... 17
20	onComputing..... 93
19	Optoelectronics..... 69
69	PacCom..... 84
21	P A I A..... 104
34	Panasonic..... 5
55	Panavise..... 103
22	Poly Paks..... 125
70	Pratt, Read & Co..... 114
58	P T S Electronics..... 92
24	Quest..... 117
23	Quimtronix..... 126
25	Radio Shack..... 75
40	Ramsey Electronics..... 129
27	Rye Industries..... 87
26	Solid State Sales..... 126
59	Southwest Technical Products..... 103
—	Spacecoast Research..... 130
—	Speakerlab, Inc..... 108
35	Tek-El Corp..... 130
—	Texas Instruments..... 96
66	Tri-Star..... 116
—	Tri-Tek..... 108
—	Trumbull..... 108
54	Ungar—Div. of Eldon Industries..... 34
46	Vaco..... 27
—	VIZ Mfg..... 87
28	Wersi Electronics..... 81
67	Zemco..... 2

MOVING?

Don't miss a single copy of **Radio-Electronics**. Give us:

Six weeks' notice

Your old address and zip code

Your new address and zip code

ATTACH LABEL HERE

name (please print) _____
 address _____
 city state zip code _____

Mall to: Radio-Electronics
 SUBSCRIPTION DEPT., P.O. BOX 2520,
 BOULDER, COLO. 80322



NEW.

Meet Super Grip II, the great new test clip from A P Products.

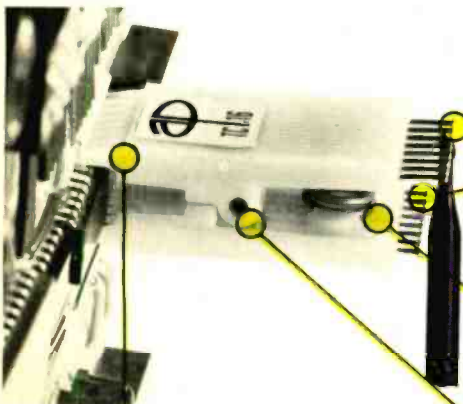

New narrow-nose design makes it easy to attach on high-density boards. And now you can test ICs with only .040" between opposing legs.

New "duck bill" contacts are flat, won't roll off IC leads.

Open-nose construction enables probe at IC leg.

Pin rows are offset for easy attachment of probes.

Contacts are gold-plated phosphor bronze. "Contact comb" construction separates contacts with precision. No shorts.

Heavy-duty, industrial-grade springs for firm contact pressure—and a good grip when pulling ICs. They'll keep their spring indefinitely. No intermittents.

Steel pivot pin. Engineering-grade thermoplastic body molded around contact pins. Made to last!

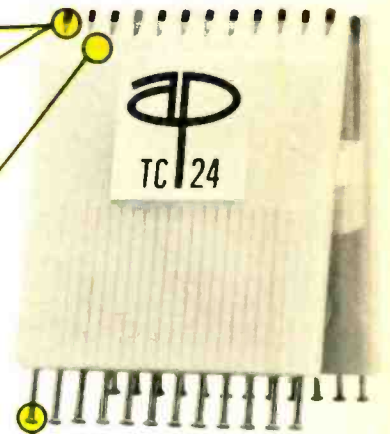

New button-head pins keep probes from sliding off. (Straight pin models for logical connections.)

The new A P Super Grip II is, without question, the best way there is to troubleshoot DIP ICs.

You get positive contacts. No intermittents. No shorts. Ever.

So it's endlessly useful to you—and it's

built to stay useful indefinitely.

Try one. You'll find 8, 14, 16, 16 LSI, 18, 20,

22, 24, 28, 36 and 40-pin models at your nearby A P store. (Make sure it's your A P store.)

Need the address? Call (toll-free) 800-321-9668. And ask for our complete A P catalog, The Faster and Easier Book.



**A P PRODUCTS
INCORPORATED**

Box 110B • 72 Corwin Drive
Painesville, Ohio 44077
Tel. 216/354-2101
TWX: 810-425-2250

Faster and Easier is what we're all about.

New, K40 Magnamount: Grips like a grapple, actually improves transmission.



We double guarantee it.*

Exclusive Octopole Construction.



That's eight magnets set in eight different directions to give you a magnetic seal so complete and powerful, your antenna would stay up there if you could squeeze between two semis passing each other at 180 miles an hour. That's magnetic octopower.

* GUARANTEE I

Placed on the roof of a vehicle; properly tuned, the K40 Magnamount is guaranteed to transmit a further distance than a standard K40 without the Magnamount or you will receive a prompt and full refund from your K40 dealer who installed and tuned the Magnamount K40 for you.

* GUARANTEE II

Materials and workmanship are guaranteed for a full 12 months. Any part that fails to perform satisfactorily will be replaced absolutely free.

Exclusive K40 Flux Harmonics for Greater Transmission.

The magnetic radiation pattern was designed to match the K40 antenna radiation for greater distance than the standard K40. See our guarantee.

The facts: Physics and Physical.

1. Magnamount is a bigger, stronger magnet—in fact it's 8 bigger, stronger, magnets.
2. It doesn't just hold the K40 antenna, it helps it transmit further.
3. Remember the law of reciprocity. The antenna that transmits better, receives better.
4. It provides a flatter, lower SWR because the Magnamount is capacitance grounded.
5. It puts your $\frac{5}{8}$ wave K40 antenna securely in place in the most advantageous place to work against a ground plane—high and free from obstruction. That's square in the middle, right up on top.

\$15.95 buys it.

(SUGGESTED RETAIL)

K40 Magnamount.

American Antenna 1945 South Street Elgin, Illinois 60120

This professional CB equipment available only through Registered K40 Dealers!

CIRCLE 3 ON FREE INFORMATION CARD