

Using Multi-pin Clamps

Large External Fixator— Modular Knee Bridge

Surgical Technique



Large External Fixator—Modular Knee Bridge

DePuy Synthes Large External Fixation devices are labeled MR Conditional according to the terminology specified in ASTM F2503-08, Standard Practice for Marking Medical Devices and Other Items for Safety in the Magnetic Resonance Environment.

Nonclinical testing demonstrated that, when used in the specific configurations stated in DePuy Synthes labeling, DePuy Synthes Large External Fixation devices are MR Conditional. Representative DePuy Synthes Large External Fixation devices used in a typical construct include clamps, rods and various attachments.

A patient with a DePuy Synthes Large External Fixation frame may be scanned safely after placement of the frame under the following conditions.

- **Static magnetic field of 1.5-Tesla** when the fixator frame is positioned outside the MRI bore at Normal Operator or in First Level Control Mode.
- **Static magnetic field of 3.0-Tesla** when the fixator frame is positioned outside the MRI bore at Normal Operator or in First Level Control Mode.
- **Highest spatial gradient magnetic field** of 720-Gauss/cm or less.
- **Maximum MR system reported** whole body averaged specific absorption rate (SAR) of 2 W/kg for the Normal Operating Mode and 4 W/kg for the First Level Controlled Mode for 15 minutes of scanning.
- **Use only whole body RF transmit coil**, no other transmit coils are allowed, local receive only coils are allowed
- **Specialty Coils**, such as knee or head coils, should not be used as they have not been evaluated for RF heating and may result in higher localized heating.

Note: In nonclinical testing, the DePuy Synthes External Fixation Devices were tested in several different configurations. This testing was conducted with the construct positioned at the edge of the MRI bore, with the entire construct outside the MRI bore.

- The results showed a maximum observed heating for a wrist fixator frame of less than 4°C for 1.5T and less than 2°C for 3.0T with a machine reported whole body averaged SAR of 2 W/kg.
- The results showed a maximum observed heating for a pelvic frame less than 1°C for 1.5 and 3.0T with a machine reported whole body averaged SAR of 2 W/kg.

Patients may be safely scanned in the MRI chamber at the above conditions. Under such conditions, the maximal expected temperature rise is less than 6°C. Because higher in vivo heating cannot be excluded, close patient monitoring and communication with the patient during the scan is required. Immediately abort the scan if the patient reports burning sensation or pain. To minimize heating, the scan time should be as short as possible, the SAR as low as possible, and the device should be as far as possible from the edge of the bore. Temperature rise values obtained were based upon a scan time of 15 minutes.

The above field conditions should be compared with those of the user's MR system, to determine if the item can safely be brought into the user's MR environment. If placed in the bore of the MR scanner during scanning, DePuy Synthes MR Conditional external fixation devices may have the potential to cause artifact in the diagnostic imaging.

All components of DePuy Synthes external fixation frames must be identified as MR Conditional prior to being placed in or near an MR environment.

Artifact information

MR image quality may be compromised if the area of interest is in the same area or relatively close to the position of the DePuy Synthes Large External Fixation construct, and it may be necessary to optimize MR imaging parameters, to compensate for the presence of the fixation frame.

Representative devices used to assemble a typical DePuy Synthes Large External Fixation frame have been evaluated in the MRI chamber and worst-case artifact information is provided below. Overall, artifacts created by DePuy Synthes Large External Fixation devices may present issues if the MR imaging area of interest is in or near the area where the fixation frame is located.

Indications and MRI Information

-
- For FFE sequence: Scan duration: 3 min, TR 100 ms, TE 15 ms, flip angle 15° and SE sequence: Scan duration: 4 min, TR 500 ms, TE 20 ms, flip angle 70° radio echo sequence, worst-case artifact will extend approximately 5 cm from the device.

Warning:

- Do not place any radio frequency (RF) transmit coils over the external fixation frame.
-

Indications

The Synthes Large External Fixation Systems is intended to provide treatment for long bone and pelvic fractures that require external fixation. Specifically, the components can be used for:

- Stabilization of soft tissues and fractures
- Polytrauma/multiple orthopaedic trauma
- Vertically stable pelvic fractures, or as a treatment adjunct for vertically unstable pelvic fractures
- Arthrodesis and osteotomies with soft tissue problems; failures of total joints
- Neutralization of fractures stabilized with limited internal fixation
- Non-unions/septic non-unions
- Intraoperative reductions/stabilization tool to assist with indirect reduction
- Unilateral rectilinear bone segment transport or leg lengthening

DePuy Synthes Large External Fixation System

Warning:

- DePuy Synthes self-drilling, self-tapping Schanz screws and Steinmann pins are not approved for screw attachment or fixation to the posterior elements (pedicles) of the cervical, thoracic, or lumbar spine.

Precautions:

- To keep from damaging the femoral cutaneous nerve, avoid pin insertion up to 15 mm in a dorsal direction from the superior anterior iliac spine.
- When dealing with the humerus, primary consideration should be given to the radial and axillary nerves. Distally, a dorsal approach to the humerus is appropriate. Proximally, it is recommendable to introduce the Schanz screws from a ventrolateral direction, caudal to the path of the axillary nerve.
- Select the appropriate Schanz screw (self-tapping, self-drilling), or Steinmann pin for the patient's bony anatomy.
- Instruments and screws may have sharp edges or moving joints that may pinch or tear user's glove or skin.
- Handle devices with care and dispose worn bone cutting instruments in an approved sharps container.
- The self-drilling Schanz screw has been developed to minimize heat development. Nevertheless, slow insertion and additional cooling (for example with a Ringer solution) are recommended.
- The tip of the self-drilling Schanz screw should be embedded in the far cortex to effectively resist cantilever forces and to provide sufficient stability.
- Only when bones are osteoporotic does the self-drilling Schanz screw have to be screwed a bit further into the distant cortical bone, and it may even slightly penetrate through it since this can increase anchoring stability.
- The tip of the self-tapping Schanz screw should be embedded in the far cortex to effectively resist cantilever forces and to provide sufficient stability.
- Implant sites should be meticulously cared for to avoid pin-tract infection. Schanz screws and Steinmann pins may be surrounded with antiseptic coated foam sponges in an effort to avoid infection. An implant-site care procedure should be reviewed with the patient.
- To help minimize the risk of pin-tract infection the following points should be observed:
 - a. Placement of Schanz screws and Steinmann pins taking anatomy into consideration (ligaments, nerves, arteries).
 - b. Slow insertion and/or cooling, particularly in dense, hard bone to avoid heat necrosis.
 - c. Release of skin tension at soft tissue entry point of implant.

Large External Fixator—Modular Knee Bridge

Technique Overview

1

Insert Schanz screws

Use the 6-Position Drill Guide Handle (392.963) or multi-pin clamp technique to ensure proper pin spacing.

2

Attach multi-pin clamps

Tighten vise plates.

3

Snap in carbon fiber rods

Attach a long carbon fiber rod to each clamp, with ends overlapping.

4

Connect carbon fiber rods

Snap together with a combination clamp.



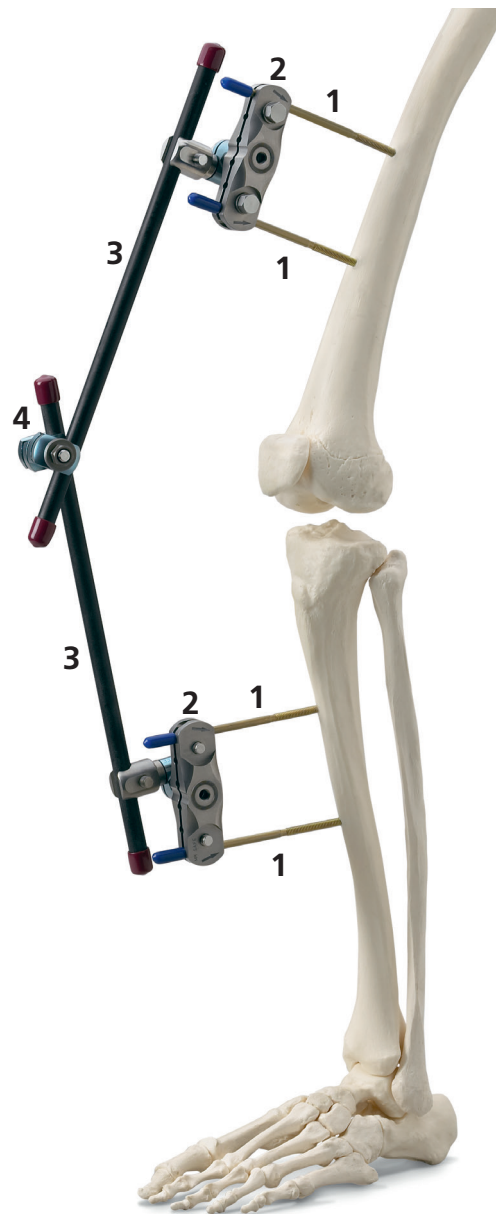

5

Reduce fracture

Reduce fracture and tighten all clamps.

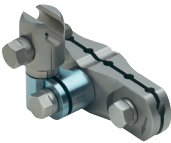
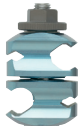

Recommended Components for Basic Frame

Product Number	Item	Quantity Needed	
494.78x	5.0 mm Titanium Self-Drilling Schanz Screw	4	
390.002	Large Multi-Pin Clamp 6 position	2	
390.005	Large Combination Clamp	1	
394.8x	11.0 mm Carbon Fiber Rod	2	
394.97	Protective Cap, for 11.0 mm Rods	4	
394.993	Protective Cap, for 5.0 mm Fixation Pins	4	

Large External Fixator—Modular Knee Bridge

When to use

This frame may be used as a temporary stabilizer for intra-articular fractures of the distal end segment of the femur and the proximal end segment of the tibia.

Pin placement

To avoid the risk of contamination, Schanz screws should be placed out of the proposed future operative site.

Multi-pin clamp technique

1

Insert first Schanz screw

Insert Schanz screw through the drill sleeve and end position of the Large Multi-Pin Clamp (390.002), using the clamp as an insertion guide.

Note: The clamp should be parallel, and the Schanz screws perpendicular, to the bone.

2

Insert second Schanz screw

Insert second Schanz screw through the opposite end of the clamp. Tighten vise plates.

Note: Additional Schanz screws may be inserted as needed.

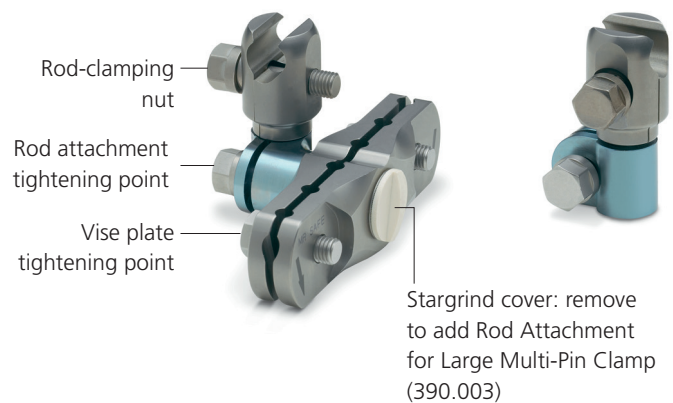
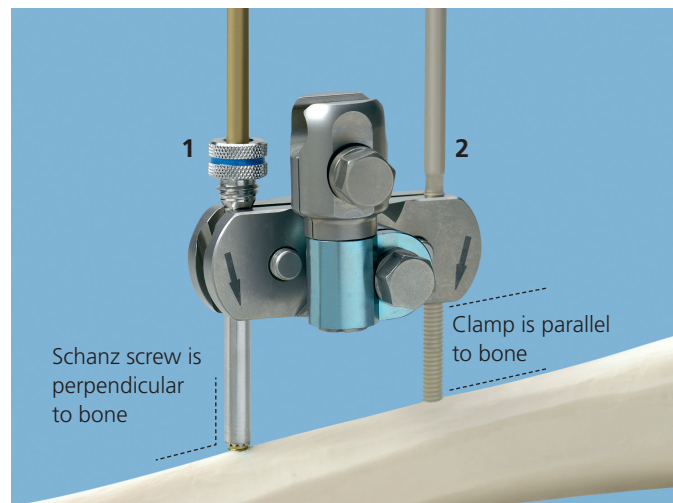

References

Behrens, F. and K. Searls. "External Fixation of the Tibia." *Journal of Bone and Joint Surgery* 68-B (1986):246-254.

Fernández, A. *Modular External Fixation in Emergency using the A.O. Tubular System*. Montevideo, Uruguay; Editorial Mar Adentro.

Optional Frame Configuration

Enhancing the frame for additional stability

1

Construct medial frame

Connect multi-pin clamps with two carbon fiber rods and a combination clamp on the medial side.

2

Connect rod attachments

Thread a rod attachment into each of the multi-pin clamps.

3

Construct lateral frame

Construct frame on the lateral side using a combination clamp and two carbon fiber rods. Tighten all clamps.



Large External Fixator Set With Self-Drilling Schanz Screws

Stainless Steel (115.720) or Titanium (115.740)

Graphic Case

690.315 Large External Fixator Graphic Case

Implants in Set 115.720, MR Conditional

293.74 5.0 mm Steinmann Pin with Central Thread, 200 mm, 4 ea.

294.56 5.0 mm Schanz Screw, blunted trocar point, 200 mm, 8 ea.

294.784 5.0 mm Self-Drilling Schanz Screws
60 mm thread/150 mm, 4 ea.

294.785 60 mm thread/175 mm, 8 ea.

294.786 80 mm thread/200 mm, 8 ea.

294.950 6.0 mm Transfixation Pin, 225 mm, 4 ea.

Implants in Set 115.740, MR Conditional

293.74 5.0 mm Steinmann Pin with Central Thread, 200 mm, 4 ea.

294.56 5.0 mm Schanz Screw, blunted trocar point, 200 mm, 8 ea.

294.950 6.0 mm Transfixation Pin, 225 mm, 4 ea.

494.784 5.0 mm Titanium Self-Drilling Schanz Screw
60 mm thread/150 mm, 4 ea.

494.785 60 mm thread/175 mm, 8 ea.

494.786 80 mm thread/200 mm, 8 ea.

Instruments (for both sets)

310.37 3.5 mm Drill Bit, quick coupling, 195 mm, 2 ea.

310.48 4.5 mm Drill Bit, quick coupling, 195 mm, 2 ea.

321.20 Ratchet Wrench, 11 mm width across flats, 2 ea.

355.14 Cannulated Socket Wrench

392.951 8.0 mm/6.0 mm Threaded Drill Sleeve, short

392.952 8.0 mm/6.0 mm Threaded Drill Sleeve, long

392.963 6-Position Drill Guide Handle

393.10 Universal Chuck with T-Handle

393.103 Drive Adaptor with quick coupling,
for 5.0 mm Schanz Screws

393.104 Drive Adaptor with quick coupling,
for 6.0 mm Schanz Screws

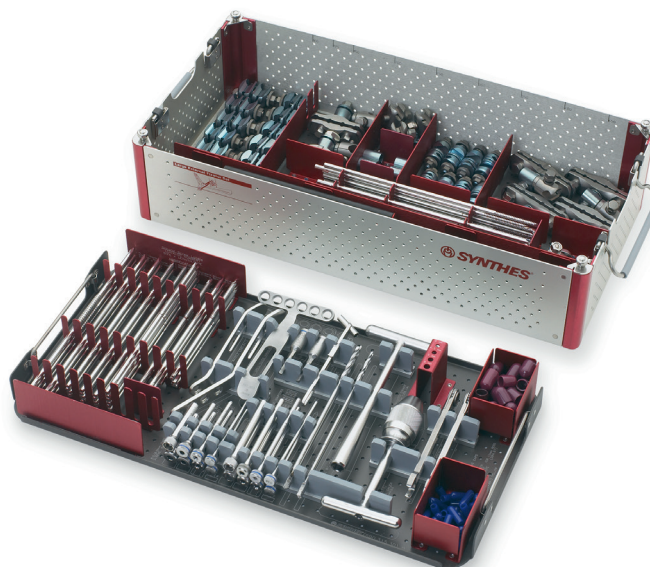

Note: For additional information, please refer to the package insert or www.e-ifu.com.

For detailed cleaning and sterilization instructions, please refer to www.depuy-synthes.com/hcp/cleaning-sterilization or sterilization instructions, if provided in the instructions for use.

Large External Fixator Set With Self-Drilling Schanz Screws

Stainless Steel (115.720) or Titanium (115.740) continued

Instruments (for both sets) continued

393.746	Split Tissue Protection Sleeve, 5.0 mm
393.76	Open Compressor, 2 ea.
394.181	3.5 mm Trocar, short
394.182	3.5 mm Trocar, long
395.911	Drill Sleeve Handle
395.912	5.0 mm/3.5 mm Drill Sleeve, short
395.913	5.0 mm/3.5 mm Drill Sleeve, long
395.921	6.0 mm/5.0 mm Threaded Drill Sleeve, short
395.923	6.0 mm/5.0 mm Threaded Drill Sleeve, long

Fixation Material (for both sets), MR Conditional

390.002	Large Multi-Pin Clamp, 6 position, 4 ea.
390.003	Rod Attachment, for Large Multi-Pin Clamp, 6 ea.
390.004	Large Multi-Pin Clamp, 4 position, 2 ea.
390.005	Large Combination Clamp, 12 ea.
390.006	Dynamization Clip, for Large Combination Clamp, 4 ea.
390.007	Tube-to-Tube Clamp, 2 ea.
390.008	Large Open Adjustable Clamp, 8 ea.
393.66*	Transverse Clamp, 2 ea.
	11.0 mm Carbon Fiber Rods, 4 ea.
394.80	100 mm
394.82	150 mm
394.83	200 mm
394.84	250 mm
394.85	300 mm
394.86	350 mm
394.87	400 mm
	Protective Caps
394.97*	For 11.0 mm Rods, (10/pkg.)
394.993*	For 5.0 mm Fixation Pins, (10/pkg.)
394.994*	For 6.0 mm Fixation Pins, (10/pkg.)

*This item has not been tested for use in the MR environment.

Also Available

Implants, MR Conditional

Schanz Screws

- 294.43-.48 4.0 mm, spade point, 60 mm–150 mm
- 294.52-.57 5.0 mm, blunted trocar point, 100 mm–250 mm
- 294.71-.76 4.5 mm, blunted trocar point, 80 mm–200 mm

Self-Drilling Schanz Screws

- 294.774-.779 4.0 mm, 60 mm–175 mm
- 294.782-.788 5.0 mm, 100 mm–250 mm
- 294.792-.798 6.0 mm, 100 mm–250 mm

Titanium Self-Drilling Schanz Screws

- 494.774-.779 4.0 mm, 60 mm–175 mm
- 494.782-.788 5.0 mm, 100 mm–250 mm
- 494.792-.798 6.0 mm, 100 mm–250 mm

Fixation Material, MR Conditional

11.0 mm Carbon Fiber Bridging Rods

- 394.796 190 mm, short
- 394.797 190 mm, long
- 394.798 220 mm, short
- 394.799 220 mm, long

Fixation Material

- 393.43* Spring-Loaded Nut
- 393.64* Adjustable Clamp
- 393.69* Open Clamp
- 393.71* Universal Joint for Two Tubes
- 393.75* Universal Clamp

Protective Caps

- 394.991* For 4.0 mm Fixation Pins, (10/pkg.)
- 394.992* For 4.5 mm Fixation Pins, (10/pkg.)

Sterile-Packaged Large External Fixator Kits

- 03.301.010S Large External Fixator Ankle Frame Kit, sterile
- 03.301.011S Large External Fixator Trauma Kit, sterile
- 03.301.012S Large External Fixator Pelvic Frame Kit, sterile



03.301.011S



394.797

*This item has not been tested for use in the MR environment.

Also Available continued

Sets

- 105.957 Power Drive Set
- 150.16 ComPact Air Drive II Set

Accessories for Graphic Case

- 690.315.12 Label Sheet Pack, for Large External Fixator Clamps
- 690.315.13 Label Sheet Pack, for Schanz Screws
- 690.315.14 Replacement Brackets, (3 sizes)
- 690.315.15 Replacement Screws, (10/pkg.)
- 690.315.17 Label Sheet, for Large External Fixator clamps

Limited Warranty and Disclaimer: DePuy Synthes products are sold with a limited warranty to the original purchaser against defects in workmanship and materials. Any other express or implied warranties, including warranties of merchantability or fitness, are hereby disclaimed.

Please also refer to the package insert(s) or other labeling associated with the devices identified in this surgical technique for additional information.

CAUTION: Federal Law restricts these devices to sale by or on the order of a physician.

Some devices listed in this technique guide may not have been licensed in accordance with Canadian law and may not be for sale in Canada. Please contact your sales consultant for items approved for sale in Canada.

Not all products may currently be available in all markets.



Manufactured or distributed by:

Synthes USA Products, LLC
1302 Wrights Lane East
West Chester, PA 19380

Synthes USA, LLC
1101 Synthes Avenue
Monument, CO 80132

Synthes GmbH
Luzernstrasse 21
4528 Zuchwil, Switzerland

To order (USA): 800-523-0322

To order (Canada): 844-243-4321

Note: For recognized manufacturer, refer to the product label.

www.depuysynthes.com