



Short bar loader

ILS-MUK 100 III

Universal short-bar automatic loader

Application area:

- Ideal for small and medium-sized batches and constrained spaces

Properties:

- Changeover time under one minute at the touch of a button
- Short reloading times thanks to high rapid feed speeds of up to 90 m/minute
- High degree of operating comfort thanks to a 14.5-cm (5.7") graphic touch display
- Process-reliable supply of rotationally symmetrical profile material
- Minimal energy consumption; no compressed air supply required
- Large storage capacity of up to 7 bars with a material diameter of 100 mm
- Chain guide: extension to 735 mm

Working range:

- Round material, diameters from 10 mm (optional 6 mm) to 104 mm
- Quadrangle – minimum edge length 6 mm, maximal enveloping circle 102 mm
- Bar lengths of 300 to 1200/1600 mm

Special features:

- Easy replacement of the spindle liner tubes thanks to radial slide of the magazine (optionally axial slide)

LED-Lichtband signalisiert den Betriebszustand



Automatik-
betrieb

Nachlade-
zyklus

Störung

ILS-MUK 100

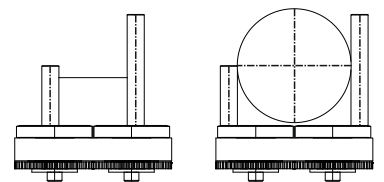

New:

- ➔ Large work area for material diameters of up to 104 mm
- ➔ Capacity extension of the chain guide to 735 mm
- ➔ Optimized loading opening, monitored by means of a light curtain

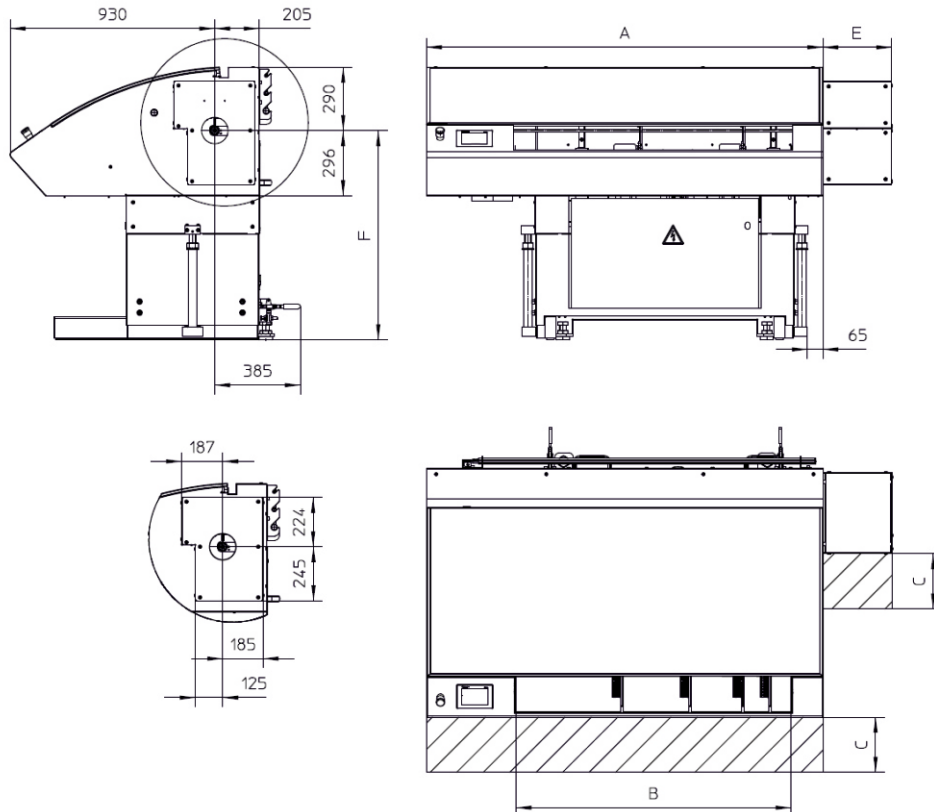

**Kurt Breuning
IRCO Maschinenbau GmbH**

Im Maurer 15
71144 Steinenbronn
DEUTSCHLAND
Fon: +49 7157 52860
Fax: +49 7157 528655
technologie@breuning-irco.de
breuning-irco.de

