



ADVANCED CONSTRUCTION & DEMOLITION EQUIPMENT

SPECSHEETS ACDE ASB 40 – 175 HYDRAULIC BREAKER



ACDE EUROPE B.V. Phone +31 316 26 72 91
Frans Halsstraat 5 E-mail info@acde-europe.com
6901DC Zevenaar **Web** www.acde-europe.com
The Netherlands **Mobile** +31 6 53 150 283

**COPYRIGHT© 2019, ACDE EUROPE BV,
ALL RIGHTS RESERVED**



ADVANCED CONSTRUCTION & DEMOLITION EQUIPMENT

ACDE ASB-40

 Hydraulische Hamer



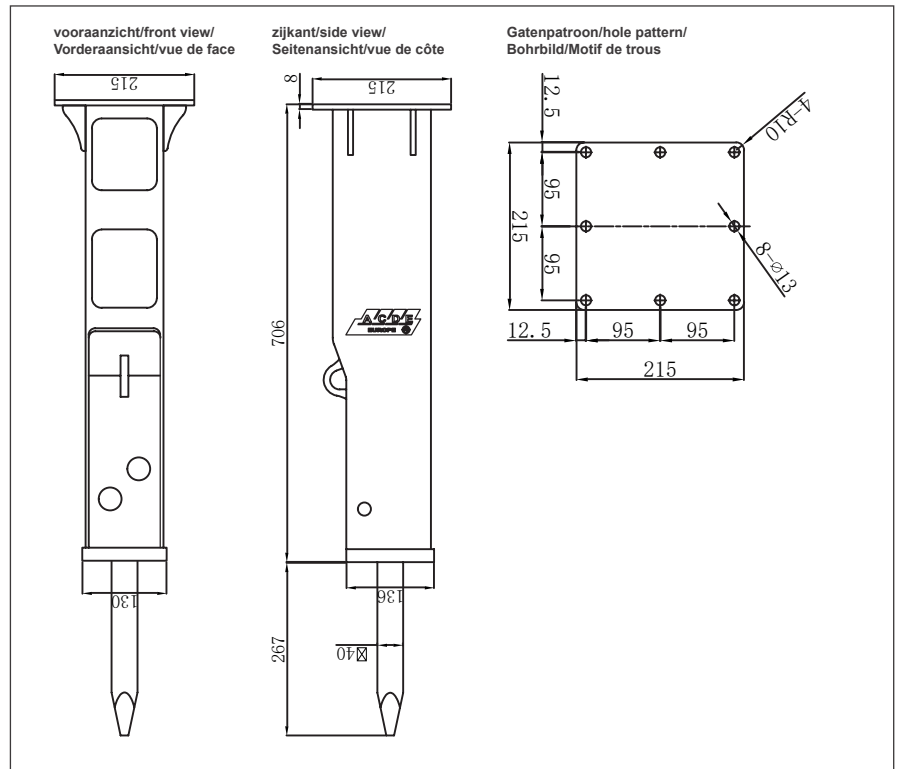

 Hydrauliek Hammer

 Hydraulic Breaker

 Marteaux Hydrauliques



Technical specifications 06/2018

NEDERLANDS 	DEUTSCH 	ENGLISH 	FRANÇAIS 		ASB-45
WERKGEWICHT	BETRIEBSGEWICHT	WORKING WEIGHT	POIDS EN ORDRE DE MARCHE	kg	85
SLAGWERK LENGTE	SCHLAGWERKLÄNGE	CYLINDER LENGHT	LONGUEUR SYSTÈME DE FRAPPE	mm	500
TOTALE LENGTE	TOTAL LÄNGE	TOTAL LENGTH	LONGUEUR TOTALE	mm	1115
OLIE DEBIET	ÖLMENGE	REQUIRED OIL FLOW	DÉBIT D'HUILE	l/min	20 - 40
WERKDRUK	BETRIEBSDRUCK	WORKING PRESSURE	PRESSION DE TRAVAIL	kg/cm ²	90 - 120
SLAGEN PER MINUUT	SCHLAGFREQUENZ	IMPACT RATE	COUPS / MINUTE	bpm	700 - 1200
BEITEL DIAMETER	WERKZEUGDURCHMESSER	CHISEL DIA	DIAMÈTRE D'OUTIL	mm	Ø40
BEITEL LENGTE	MEISSEL LÄNGE	CHISEL LENGHT	LONGUEUR D'OUTIL	mm	500
SLANG AANSLUITING	SCHLAUCH ANSCHLUSS	HOSE DIA	CONNECTION TUYAUX	inch	1/2
ZUIGERACCUMULATOR DRUK	KOLBENSPEICHER DRUCK	BACK HEAD PRESSURE	PRESSION PISTON ACCUMULATEUR	kg/cm ²	14 - 17
ACCUMULATOR DRUK	AKKUMULATOR DRUCK	ACCUMULATOR PRESSURE	PRESSION ACCUMULATEUR	kg/cm ²	none
GRAAFMACHINE KLASSE	BAGGERGRÖSSE	APPLICABLE EXCAVATOR	ENGIN PORTEUR CLASSE	ton	0,8 - 1,5
SLAGKRACHT	SCHLAGENERGIE	IMPACT POWER	FORCE D'IMPACT	J	250

ACDE EUROPE B.V.
Frans Halsstraat 5
6901 DC Zevenaar
The Netherlands

Phone
E-mail
Web
Mobile

+31 316 26 72 91
info@acde-europe.com
www.acde-europe.com
+31 6 53 150 283



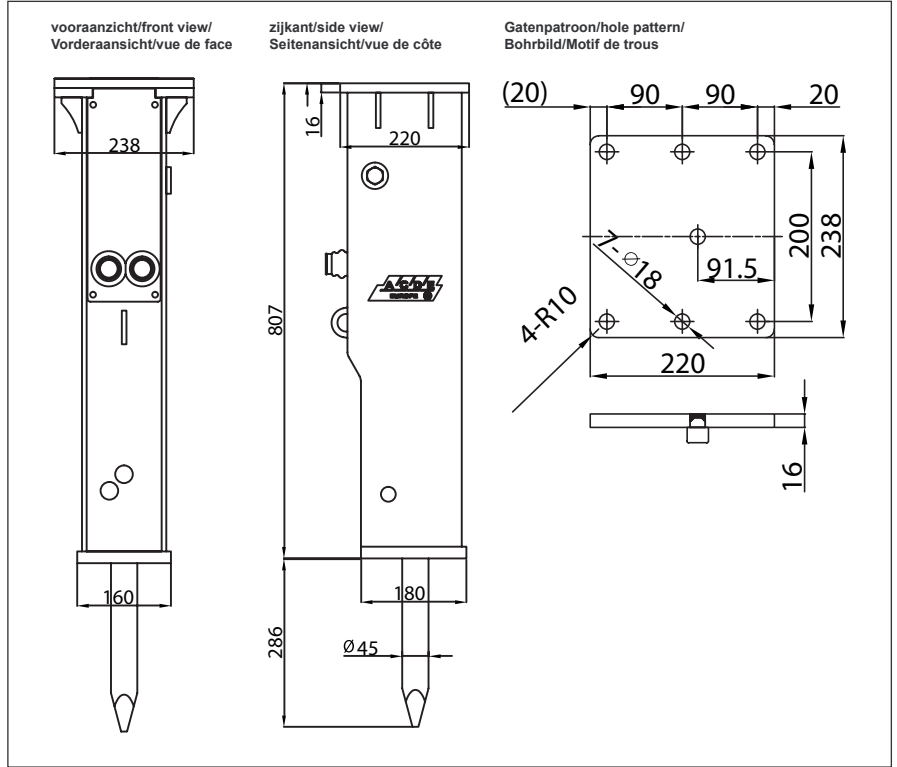

COPYRIGHT © 2018, ACDE EUROPE BV,
ALL RIGHTS RESERVED

ACDE ASB-45

 **Hydraulische Hamer**  **Hydrauliek Hammer**
 **Hydraulic Breaker**  **Marteaux Hydrauliques**



Technical specifications 01/2018



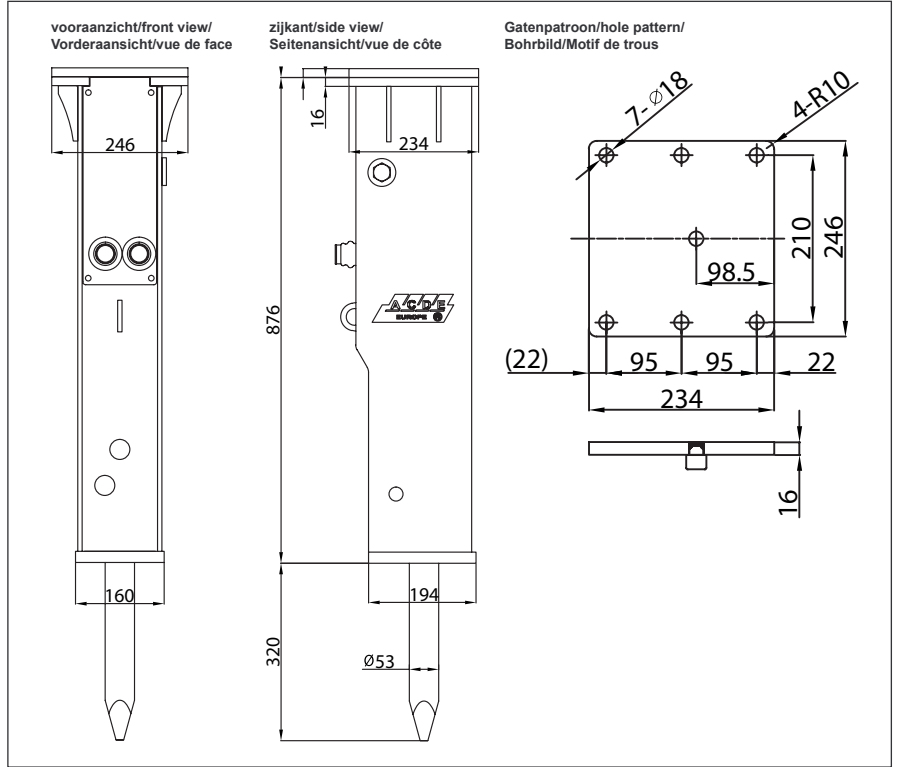

NEDERLANDS 	DEUTSCH 	ENGLISH 	FRANÇAIS 		ASB-45
WERKGEWICHT	BETRIEBSGEWICHT	WORKING WEIGHT	POIDS EN ORDRE DE MARCHÉ	kg	125
SLAGWERK LENGTE	SCHLAGWERKLÄNGE	CYLINDER LENGHT	LONGUEUR SYSTÈME DE FRAPPE	mm	745
TOTALE LENGTE	TOTAL LÄNGE	TOTAL LENGTH	LONGUEUR TOTALE	mm	1120
OLIE DEBIET	ÖLMENGE	REQUURED OIL FLOW	DÉBIT D'HUILE	l/min	20 - 40
WERKDRUK	BETRIEBSDRUCK	WORKING PRESSURE	PRESSION DE TRAVAIL	kg/cm ²	90 - 120
SLAGEN PER MINUUT	SCHLAGFREQUENZ	IMPACT RATE	COUPS / MINUTE	bpm	700 - 1200
BEITEL DIAMETER	WERKZEUGDURCHMESSER	CHISEL DIA	DIAMÈTRE D'OUTIL	mm	Ø45
BEITEL LENGTE	MEISSEL LÄNGE	CHISEL LENGHT	LONGUEUR D'OUTIL	mm	500
SLANG AANSLUITING	SCHLAUCH ANSCHLUSS	HOSE DIA	CONNECTION TUYAUX	inch	1/2
ZUIGERACCUMULATOR DRUK	KOLBENSPEICHER DRUCK	BACK HEAD PRESSURE	PRESSION PISTON ACCUMULATEUR	kg/cm ²	14 - 17
ACCUMULATOR DRUK	AKKUMULATOR DRUCK	ACCUMULATOR PRESSURE	PRESSION ACCUMULATEUR	kg/cm ²	none
GRAAFMACHINE KLASSE	BAGGERGRÖSSE	APPLICABLE EXCAVATOR	ENGIN PORTEUR CLASSE	ton	0,8 - 1,5
SLAGKRACHT	SCHLAGENERGIE	IMPACT POWER	FORCE D'IMPACT	J	250

ACDE ASB-53

 **Hydraulische Hamer**
  **Hydrauliek Hammer**
 **Hydraulic Breaker**
  **Marteaux Hydrauliques**



Technical specifications 01/2018



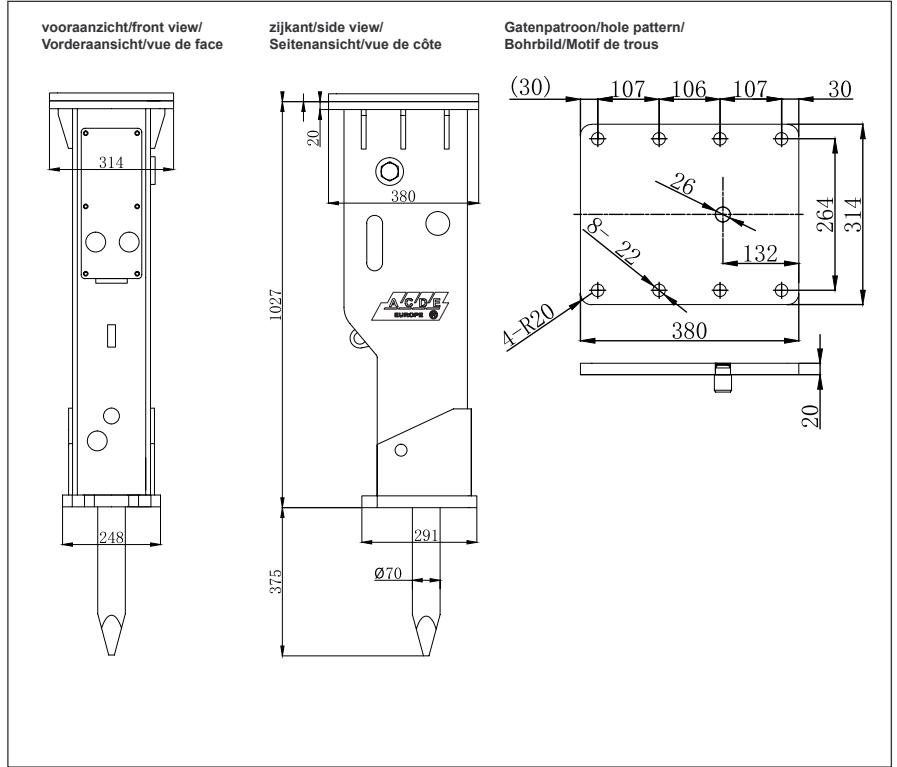

NEDERLANDS 	DEUTSCH 	ENGLISH 	FRANÇAIS 		ASB-53
WERKGEWICHT	BETRIEBSGEWICHT	WORKING WEIGHT	POIDS EN ORDRE DE MARCHÉ	kg	156
SLAGWERK LENGTE	SCHLAGWERKLÄNGE	CYLINDER LENGHT	LONGUEUR SYSTÈME DE FRAPPE	mm	823
TOTALE LENGTE	TOTAL LÄNGE	TOTAL LENGTH	LONGUEUR TOTALE	mm	1140
OLIE DEBIET	ÖLMENGE	REQUURED OIL FLOW	DÉBIT D'HUILE	l/min	20 - 50
WERKDRUK	BETRIEBSDRUCK	WORKING PRESSURE	PRESSION DE TRAVAIL	kg/cm ²	90 - 120
SLAGEN PER MINUUT	SCHLAGFREQUENZ	IMPACT RATE	COUPS / MINUTE	bpm	600 - 1100
BEITEL DIAMETER	WERKZEUGDURCHMESSER	CHISEL DIA	DIAMÈTRE D'OUTIL	mm	Ø53
BEITEL LENGTE	MEISSEL LÄNGE	CHISEL LENGHT	LONGUEUR D'OUTIL	mm	580
SLANG AANSLUITING	SCHLAUCH ANSCHLUSS	HOSE DIA	CONNECTION TUYAUX	inch	1/2
ZUIGERACCUMULATOR DRUK	KOLBENSPEICHER DRUCK	BACK HEAD PRESSURE	PRESSION PISTON ACCUMULATEUR	kg/cm ²	14 - 17
ACCUMULATOR DRUK	AKKUMULATOR DRUCK	ACCUMULATOR PRESSURE	PRESSION ACCUMULATEUR	kg/cm ²	none
GRAAFMACHINE KLASSE	BAGGERGRÖSSE	APPLICABLE EXCAVATOR	ENGIN PORTEUR CLASSE	ton	1,5 - 3,5
SLAGKRACHT	SCHLAGENERGIE	IMPACT POWER	FORCE D'IMPACT	J	350

ACDE ASB-70

 **Hydraulische Hamer**  **Hydrauliek Hammer**
 **Hydraulic Breaker**  **Marteaux Hydrauliques**



Technical specifications 01/2018



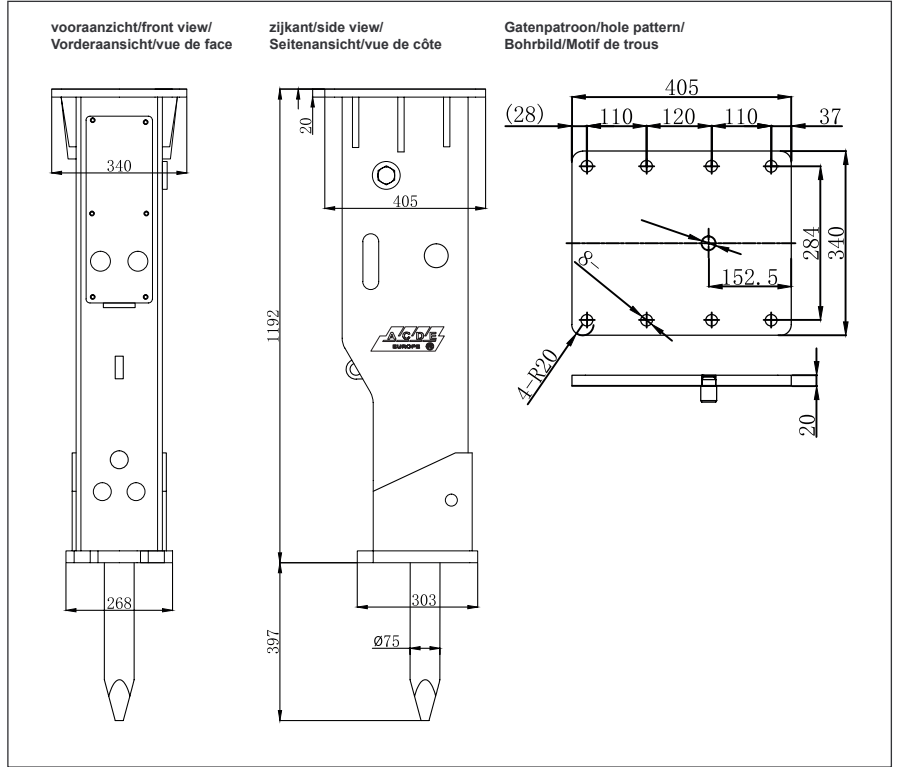

NEDERLANDS 	DEUTSCH 	ENGLISH 	FRANÇAIS 		ASB-70
WERKGEWICHT	BETRIEBSGEWICHT	WORKING WEIGHT	POIDS EN ORDRE DE MARCHÉ	kg	320
SLAGWERK LENGTE	SCHLAGWERKLÄNGE	CYLINDER LENGHT	LONGUEUR SYSTÈME DE FRAPPE	mm	937
TOTALE LENGTE	TOTAL LÄNGE	TOTAL LENGTH	LONGUEUR TOTALE	mm	1360
OLIE DEBIET	ÖLMENGE	REQUURED OIL FLOW	DÉBIT D'HUILE	l/min	40 - 70
WERKDRUK	BETRIEBSDRUCK	WORKING PRESSURE	PRESSION DE TRAVAIL	kg/cm ²	110 - 140
SLAGEN PER MINUUT	SCHLAGFREQUENZ	IMPACT RATE	COUPS / MINUTE	bpm	500 - 900
BEITEL DIAMETER	WERKZEUGDURCHMESSER	CHISEL DIA	DIAMÈTRE D'OUTIL	mm	Ø70
BEITEL LENGTE	MEISSEL LÄNGE	CHISEL LENGHT	LONGUEUR D'OUTIL	mm	700
SLANG AANSLUITING	SCHLAUCH ANSCHLUSS	HOSE DIA	CONNECTION TUYAUX	inch	1/2
ZUIGERACCUMULATOR DRUK	KOLBENSPEICHER DRUCK	BACK HEAD PRESSURE	PRESSION PISTON ACCUMULATEUR	kg/cm ²	14 - 17
ACCUMULATOR DRUK	AKKUMULATOR DRUCK	ACCUMULATOR PRESSURE	PRESSION ACCUMULATEUR	kg/cm ²	none
GRAAFMACHINE KLASSE	BAGGERGRÖSSE	APPLICABLE EXCAVATOR	ENGIN PORTEUR CLASSE	ton	4 - 6
SLAGKRACHT	SCHLAGENERGIE	IMPACT POWER	FORCE D'IMPACT	J	540

ACDE ASB-75

 **Hydraulische Hamer**  **Hydrauliek Hammer**
 **Hydraulic Breaker**  **Marteaux Hydrauliques**



Technical specifications 01/2018



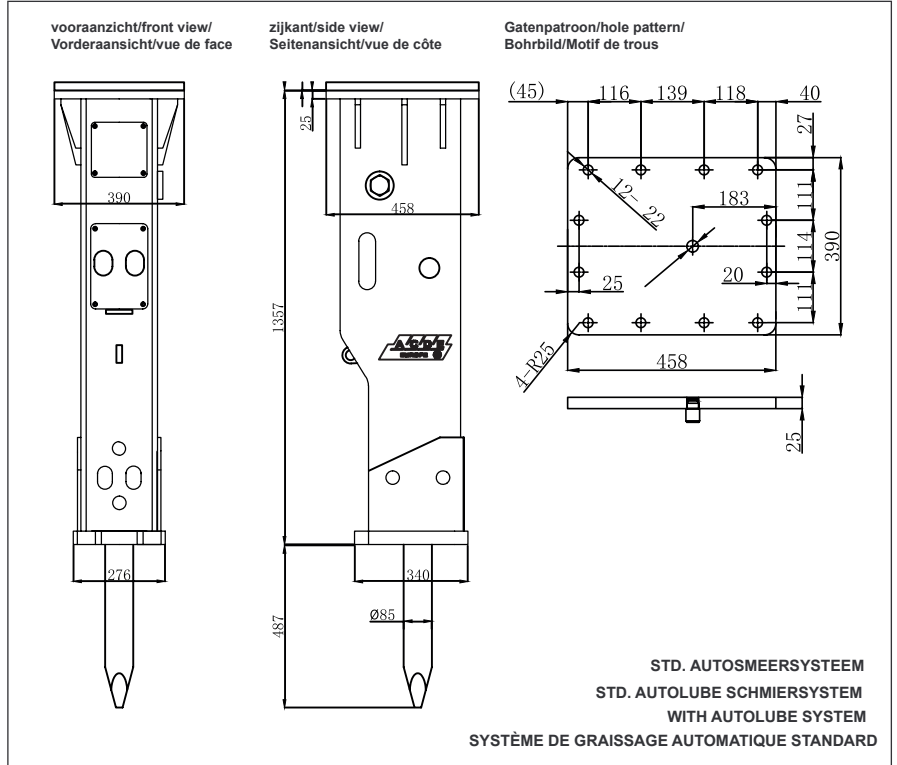

NEDERLANDS 	DEUTSCH 	ENGLISH 	FRANÇAIS 		ASB-75
WERKGEWICHT	BETRIEBSGEWICHT	WORKING WEIGHT	POIDS EN ORDRE DE MARCHÉ	kg	415
SLAGWERK LENGTE	SCHLAGWERKLÄNGE	CYLINDER LENGHT	LONGUEUR SYSTÈME DE FRAPPE	mm	1110
TOTALE LENGTE	TOTAL LÄNGE	TOTAL LENGTH	LONGUEUR TOTALE	mm	1560
OLIE DEBIET	ÖLMENGE	REQUURED OIL FLOW	DÉBIT D'HUILE	l/min	50 - 90
WERKDRUK	BETRIEBSDRUCK	WORKING PRESSURE	PRESSION DE TRAVAIL	kg/cm ²	120 - 150
SLAGEN PER MINUUT	SCHLAGFREQUENZ	IMPACT RATE	COUPS / MINUTE	bpm	400 - 800
BEITEL DIAMETER	WERKZEUGDURCHMESSER	CHISEL DIA	DIAMÈTRE D'OUTIL	mm	Ø75
BEITEL LENGTE	MEISSEL LÄNGE	CHISEL LENGHT	LONGUEUR D'OUTIL	mm	750
SLANG AANSLUITING	SCHLAUCH ANSCHLUSS	HOSE DIA	CONNECTION TUYAUX	inch	1/2
ZUIGERACCUMULATOR DRUK	KOLBENSPEICHER DRUCK	BACK HEAD PRESSURE	PRESSION PISTON ACCUMULATEUR	kg/cm ²	14 - 17
ACCUMULATOR DRUK	AKKUMULATOR DRUCK	ACCUMULATOR PRESSURE	PRESSION ACCUMULATEUR	kg/cm ²	none
GRAAFMACHINE KLASSE	BAGGERGRÖSSE	APPLICABLE EXCAVATOR	ENGIN PORTEUR CLASSE	ton	6 - 9
SLAGKRACHT	SCHLAGENERGIE	IMPACT POWER	FORCE D'IMPACT	J	785

ACDE ASB-85

 **Hydraulische Hamer**
  **Hydrauliek Hammer**
 **Hydraulic Breaker**
  **Marteaux Hydrauliques**



Technical specifications 01/2018



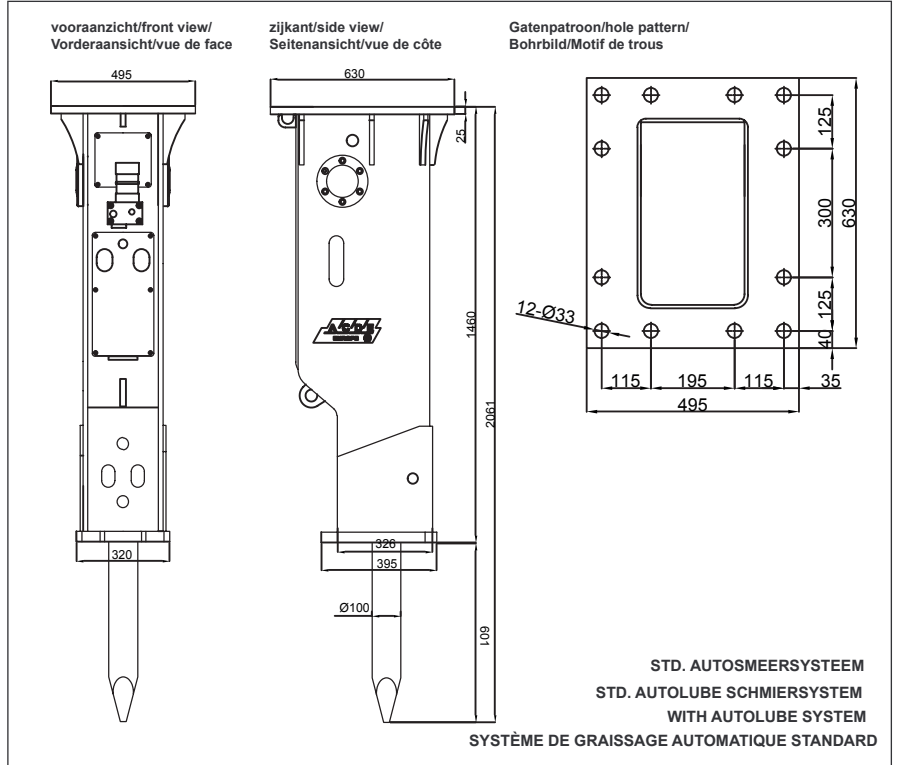

NEDERLANDS 	DEUTSCH 	ENGLISH 	FRANÇAIS 		ASB-85
WERKGEWICHT	BETRIEBSGEWICHT	WORKING WEIGHT	POIDS EN ORDRE DE MARCHÉ	kg	580
SLAGWERK LENGTE	SCHLAGWERKLÄNGE	CYLINDER LENGHT	LONGUEUR SYSTÈME DE FRAPPE	mm	1261
TOTALE LENGTE	TOTAL LÄNGE	TOTAL LENGTH	LONGUEUR TOTALE	mm	1775
OLIE DEBIET	ÖLMENGE	REQUURED OIL FLOW	DÉBIT D'HUILE	l/min	60 - 100
WERKDRUK	BETRIEBSDRUCK	WORKING PRESSURE	PRESSION DE TRAVAIL	kg/cm ²	130 - 160
SLAGEN PER MINUUT	SCHLAGFREQUENZ	IMPACT RATE	COUPS / MINUTE	bpm	400 - 800
BEITEL DIAMETER	WERKZEUGDURCHMESSER	CHISEL DIA	DIAMÈTRE D'OUTIL	mm	Ø85
BEITEL LENGTE	MEISSEL LÄNGE	CHISEL LENGHT	LONGUEUR D'OUTIL	mm	850
SLANG AANSLUITING	SCHLAUCH ANSCHLUSS	HOSE DIA	CONNECTION TUYAUX	inch	3/4
ZUIGERACCUMULATOR DRUK	KOLBENSPEICHER DRUCK	BACK HEAD PRESSURE	PRESSION PISTON ACCUMULATEUR	kg/cm ²	14 - 17
ACCUMULATOR DRUK	AKKUMULATOR DRUCK	ACCUMULATOR PRESSURE	PRESSION ACCUMULATEUR	kg/cm ²	none
GRAAFMACHINE KLASSE	BAGGERGRÖSSE	APPLICABLE EXCAVATOR	ENGIN PORTEUR CLASSE	ton	7 - 11
SLAGKRACHT	SCHLAGENERGIE	IMPACT POWER	FORCE D'IMPACT	J	1260

ACDE ASB-100 A

 **Hydraulische Hamer**  **Hydrauliek Hammer**
 **Hydraulic Breaker**  **Marteaux Hydrauliques**



Technical specifications 01/2018



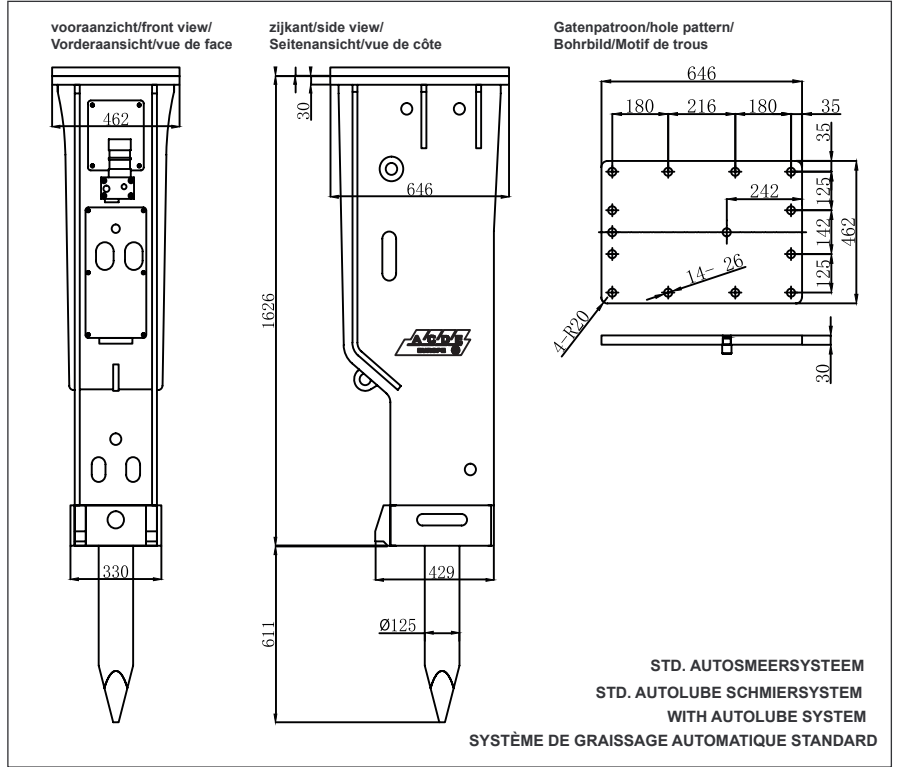

NEDERLANDS 	DEUTSCH 	ENGLISH 	FRANÇAIS 		ASB-100 A
WERKGEWICHT	BETRIEBSGEWICHT	WORKING WEIGHT	POIDS EN ORDRE DE MARCHÉ	kg	865
SLAGWERK LENGTE	SCHLAGWERKLÄNGE	CYLINDER LENGHT	LONGUEUR SYSTÈME DE FRAPPE	mm	1373
TOTALE LENGTE	TOTAL LÄNGE	TOTAL LENGTH	LONGUEUR TOTALE	mm	1980
OLIE DEBIET	ÖLMENGE	REQUURED OIL FLOW	DÉBIT D'HUILE	l/min	80 - 110
WERKDRUK	BETRIEBSDRUCK	WORKING PRESSURE	PRESSION DE TRAVAIL	kg/cm ²	150 - 170
SLAGEN PER MINUUT	SCHLAGFREQUENZ	IMPACT RATE	COUPS / MINUTE	bpm	350 - 700
BEITEL DIAMETER	WERKZEUGDURCHMESSER	CHISEL DIA	DIAMÈTRE D'OUTIL	mm	Ø100
BEITEL LENGTE	MEISSEL LÄNGE	CHISEL LENGHT	LONGUEUR D'OUTIL	mm	1000
SLANG AANSLUITING	SCHLAUCH ANSCHLUSS	HOSE DIA	CONNECTION TUYAUX	inch	3/4
ZUIGERACCUMULATOR DRUK	KOLBENSPEICHER DRUCK	BACK HEAD PRESSURE	PRESSION PISTON ACCUMULATEUR	kg/cm ²	14 - 17
ACCUMULATOR DRUK	AKKUMULATOR DRUCK	ACCUMULATOR PRESSURE	PRESSION ACCUMULATEUR	kg/cm ²	55 - 60
GRAAFMACHINE KLASSE	BAGGERGRÖSSE	APPLICABLE EXCAVATOR	ENGIN PORTEUR CLASSE	ton	10 - 14
SLAGKRACHT	SCHLAGENERGIE	IMPACT POWER	FORCE D'IMPACT	J	1960

ACDE ASB-125 A

 **Hydraulische Hamer**  **Hydrauliek Hammer**
 **Hydraulic Breaker**  **Marteaux Hydrauliques**



Technical specifications 01/2018



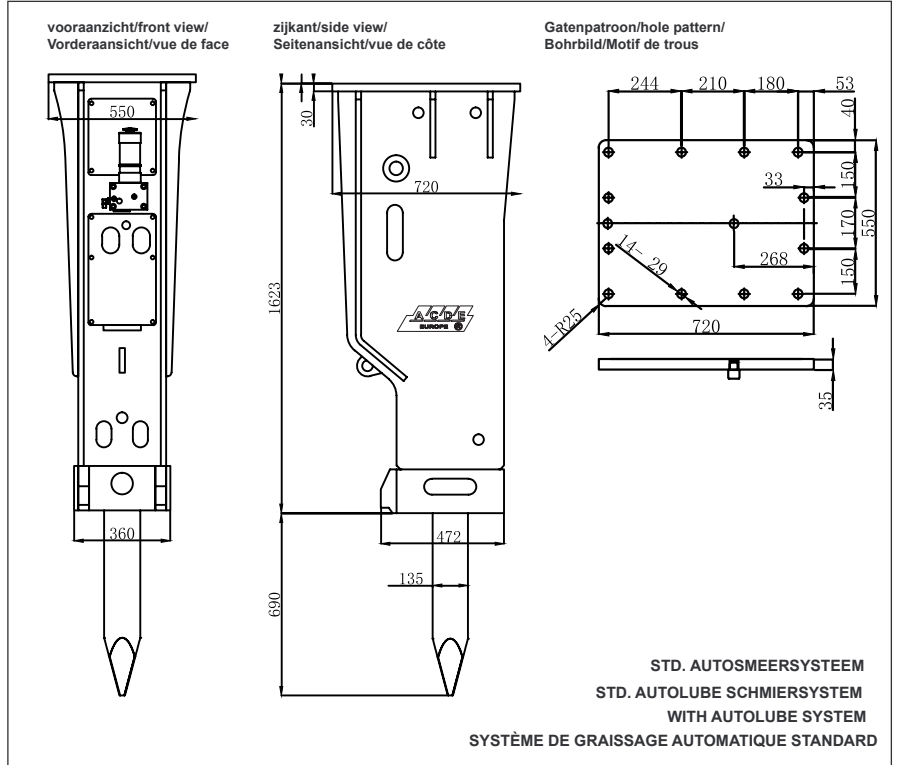

NEDERLANDS 	DEUTSCH 	ENGLISH 	FRANÇAIS 		ASB-125 A
WERKGEWICHT	BETRIEBSGEWICHT	WORKING WEIGHT	POIDS EN ORDRE DE MARCHÉ	kg	1240
SLAGWERK LENGTE	SCHLAGWERKLÄNGE	CYLINDER LENGHT	LONGUEUR SYSTÈME DE FRAPPE	mm	1543
TOTALE LENGTE	TOTAL LÄNGE	TOTAL LENGTH	LONGUEUR TOTALE	mm	2236
OLIE DEBIET	ÖLMENGE	REQUURED OIL FLOW	DÉBIT D'HUILE	l/min	90 - 120
WERKDRUK	BETRIEBSDRUCK	WORKING PRESSURE	PRESSION DE TRAVAIL	kg/cm ²	150 - 170
SLAGEN PER MINUUT	SCHLAGFREQUENZ	IMPACT RATE	COUPS / MINUTE	bpm	350 - 650
BEITEL DIAMETER	WERKZEUGDURCHMESSER	CHISEL DIA	DIAMÈTRE D'OUTIL	mm	Ø125
BEITEL LENGTE	MEISSEL LÄNGE	CHISEL LENGHT	LONGUEUR D'OUTIL	mm	1100
SLANG AANSLUITING	SCHLAUCH ANSCHLUSS	HOSE DIA	CONNECTION TUYAUX	inch	1
ZUIGERACCUMULATOR DRUK	KOLBENSPEICHER DRUCK	BACK HEAD PRESSURE	PRESSION PISTON ACCUMULATEUR	kg/cm ²	14 - 17
ACCUMULATOR DRUK	AKKUMULATOR DRUCK	ACCUMULATOR PRESSURE	PRESSION ACCUMULATEUR	kg/cm ²	55 - 60
GRAAFMACHINE KLASSE	BAGGERGRÖSSE	APPLICABLE EXCAVATOR	ENGIN PORTEUR CLASSE	ton	14 - 18
SLAGKRACHT	SCHLAGENERGIE	IMPACT POWER	FORCE D'IMPACT	J	2550

ACDE ASB-135 A

 **Hydraulische Hamer**  **Hydrauliek Hammer**
 **Hydraulic Breaker**  **Marteaux Hydrauliques**



Technical specifications 01/2018



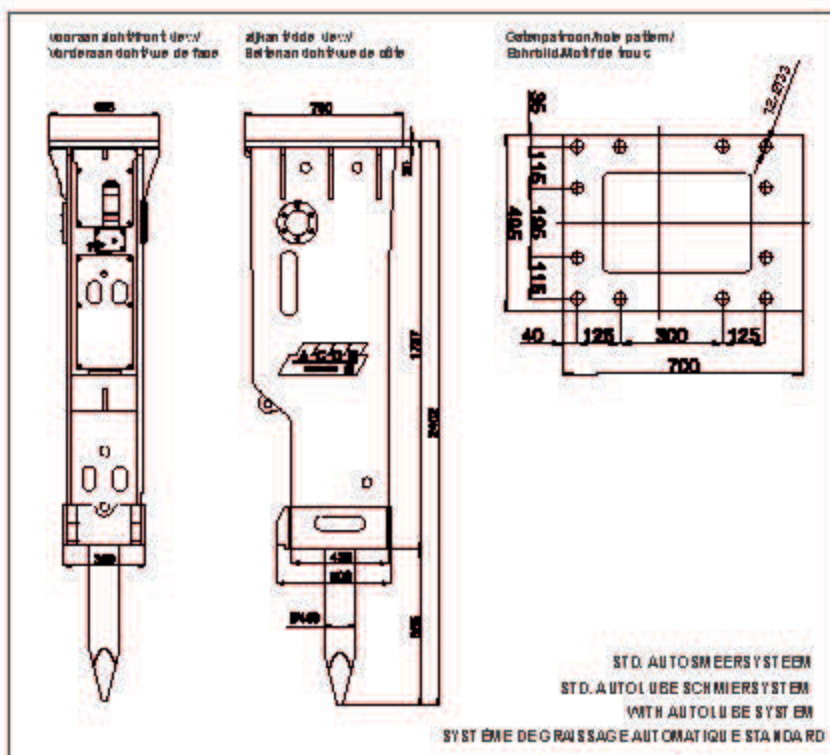

NEDERLANDS 	DEUTSCH 	ENGLISH 	FRANÇAIS 		ASB-135 A
WERKGEWICHT	BETRIEBSGEWICHT	WORKING WEIGHT	POIDS EN ORDRE DE MARCHÉ	kg	1550
SLAGWERK LENGTE	SCHLAGWERKLÄNGE	CYLINDER LENGHT	LONGUEUR SYSTÈME DE FRAPPE	mm	1540
TOTALE LENGTE	TOTAL LÄNGE	TOTAL LENGTH	LONGUEUR TOTALE	mm	2327
OLIE DEBIET	ÖLMENGE	REQUURED OIL FLOW	DÉBIT D'HUILE	l/min	100 - 150
WERKDRUK	BETRIEBSDRUCK	WORKING PRESSURE	PRESSION DE TRAVAIL	kg/cm ²	160 - 180
SLAGEN PER MINUUT	SCHLAGFREQUENZ	IMPACT RATE	COUPS / MINUTE	bpm	350 - 500
BEITEL DIAMETER	WERKZEUGDURCHMESSER	CHISEL DIA	DIAMÈTRE D'OUTIL	mm	Ø135
BEITEL LENGTE	MEISSEL LÄNGE	CHISEL LENGHT	LONGUEUR D'OUTIL	mm	1200
SLANG AANSLUITING	SCHLAUCH ANSCHLUSS	HOSE DIA	CONNECTION TUYAUX	inch	1
ZUIGERACCUMULATOR DRUK	KOLBENSPEICHER DRUCK	BACK HEAD PRESSURE	PRESSION PISTON ACCUMULATEUR	kg/cm ²	6 - 8
ACCUMULATOR DRUK	AKKUMULATOR DRUCK	ACCUMULATOR PRESSURE	PRESSION ACCUMULATEUR	kg/cm ²	55 - 60
GRAAFMACHINE KLASSE	BAGGERGRÖSSE	APPLICABLE EXCAVATOR	ENGIN PORTEUR CLASSE	ton	18 - 22
SLAGKRACHT	SCHLAGENERGIE	IMPACT POWER	FORCE D'IMPACT	J	3480

ACDE ASB-140 A

 **Hydraulische Hamer**  **Hydraulisch Hammer**
 **Hydraulic Breaker**  **Marteau Hydraulique**



Technical specifications 01/2018



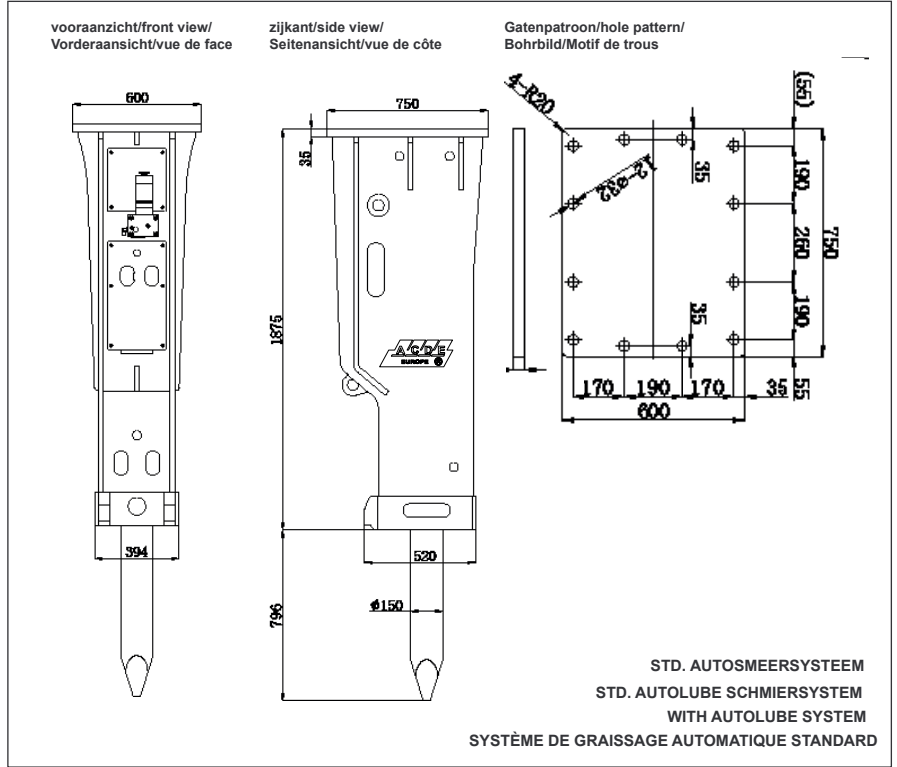

NEDERLANDS 	DEUTSCH 	ENGLISH 	FRANÇAIS 	ASB-140 A	
WERKGEWICHT	BETRIEBSGEWICHT	WORKING WEIGHT	POIDS EN ORDRE DE MARCHÉ	kg	1570
SLAGWERK LENGTE	SCHLAGWERKLÄNGE	CYLINDER LENGTH	LONGUEUR SYSTÈME DE FRAPPE	mm	1652
TOTALE LENGTE	TOTAL LÄNGE	TOTAL LENGTH	LONGUEUR TOTALE	mm	2410
OLIE DEBIET	ÖLMENGE	REQUIRED OIL FLOW	DÉBIT D'HUILE	l/min	120 - 180
WERKDRUK	BETRIEBSDRUCK	WORKING PRESSURE	PRESSION DE TRAVAIL	kg/cm ²	160 - 180
SLAGEN PER MINUUT	SCHLAGFREQUENZ	IMPACT RATE	COUPS / MINUTE	bpm	350 - 500
BEITEL DIAMETER	WERKZEUGDURCHMESSER	CHISEL DIA	DIAMÈTRE D'OUTIL	mm	Ø140
BEITEL LENGTE	MEISSEL LÄNGE	CHISEL LENGTH	LONGUEUR D'OUTIL	mm	1250
SLANG AANSLUITING	SCHLAUCHANSCHLUSS	HOSE DIA	CONNECTION TUYAUX	inch	1
ZUGERACCUMULATOR DRUK	KOLBENSPEICHER DRUCK	BACK HEAD PRESSURE	PRESSION PISTON ACCUMULATEUR	kg/cm ²	14 - 17
ACCUMULATOR DRUK	AKKUMULATOR DRUCK	ACCUMULATOR PRESSURE	PRESSION ACCUMULATEUR	kg/cm ²	55 - 60
GRAAFMACHINE KLASSE	BAGGERGRÖSSE	APPLICABLE EXCAVATOR	ENGIN PORTEUR CLASSE	ton	20 - 24
SLAGKRACHT	SCHLAGENERGIE	IMPACT POWER	FORCE D'IMPACT	J	3690

ACDE ASB-150

 **Hydraulische Hamer**  **Hydrauliek Hammer**
 **Hydraulic Breaker**  **Marteaux Hydrauliques**



Technical specifications 01/2018



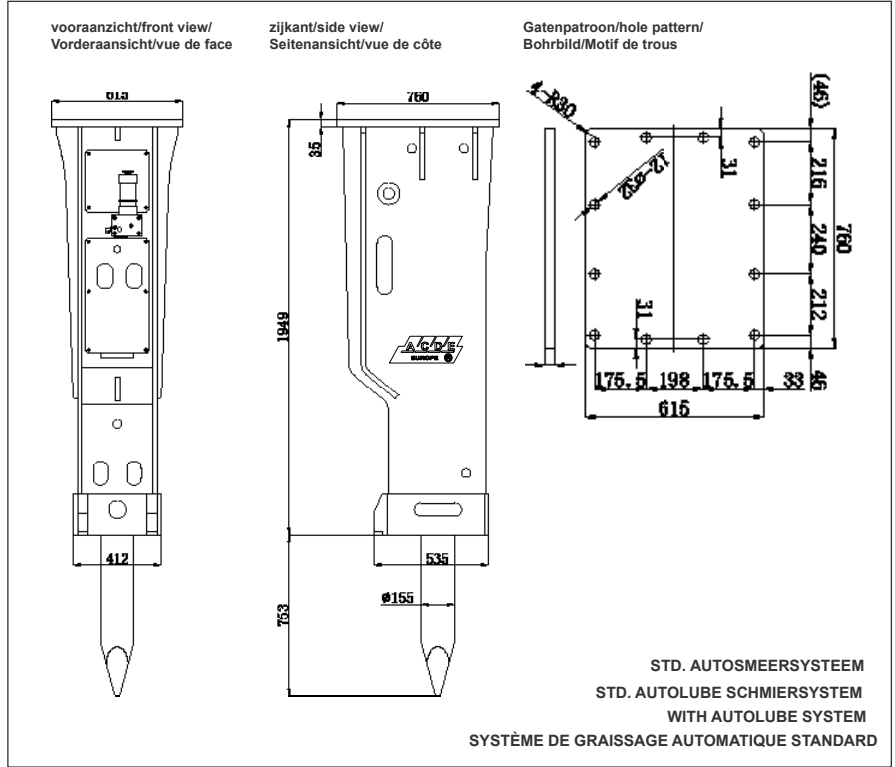

NEDERLANDS 	DEUTSCH 	ENGLISH 	FRANÇAIS 		ASB-150
WERKGEWICHT	BETRIEBSGEWICHT	WORKING WEIGHT	POIDS EN ORDRE DE MARCHÉ	kg	2250
SLAGWERK LENGTE	SCHLAGWERKLÄNGE	CYLINDER LENGHT	LONGUEUR SYSTÈME DE FRAPPE	mm	1765
TOTALE LENGTE	TOTAL LÄNGE	TOTAL LENGTH	LONGUEUR TOTALE	mm	2616
OLIE DEBIET	ÖLMENGE	REQUURED OIL FLOW	DÉBIT D'HUILE	l/min	150 - 210
WERKDRUK	BETRIEBSDRUCK	WORKING PRESSURE	PRESSION DE TRAVAIL	kg/cm ²	160 - 180
SLAGEN PER MINUUT	SCHLAGFREQUENZ	IMPACT RATE	COUPS / MINUTE	bpm	300 - 450
BEITEL DIAMETER	WERKZEUGDURCHMESSER	CHISEL DIA	DIAMÈTRE D'OUTIL	mm	Ø150
BEITEL LENGTE	MEISSEL LÄNGE	CHISEL LENGHT	LONGUEUR D'OUTIL	mm	1400
SLANG AANSLUITING	SCHLAUCH ANSCHLUSS	HOSE DIA	CONNECTION TUYAUX	inch	1
ZUIGERACCUMULATOR DRUK	KOLBENSPEICHER DRUCK	BACK HEAD PRESSURE	PRESSION PISTON ACCUMULATEUR	kg/cm ²	17 - 20
ACCUMULATOR DRUK	AKKUMULATOR DRUCK	ACCUMULATOR PRESSURE	PRESSION ACCUMULATEUR	kg/cm ²	55 - 60
GRAAFMACHINE KLASSE	BAGGERGRÖSSE	APPLICABLE EXCAVATOR	ENGIN PORTEUR CLASSE	ton	24 - 27
SLAGKRACHT	SCHLAGENERGIE	IMPACT POWER	FORCE D'IMPACT	J	5300

ACDE ASB-155

 **Hydraulische Hamer**  **Hydrauliek Hammer**
 **Hydraulic Breaker**  **Marteaux Hydrauliques**



Technical specifications 01/2018



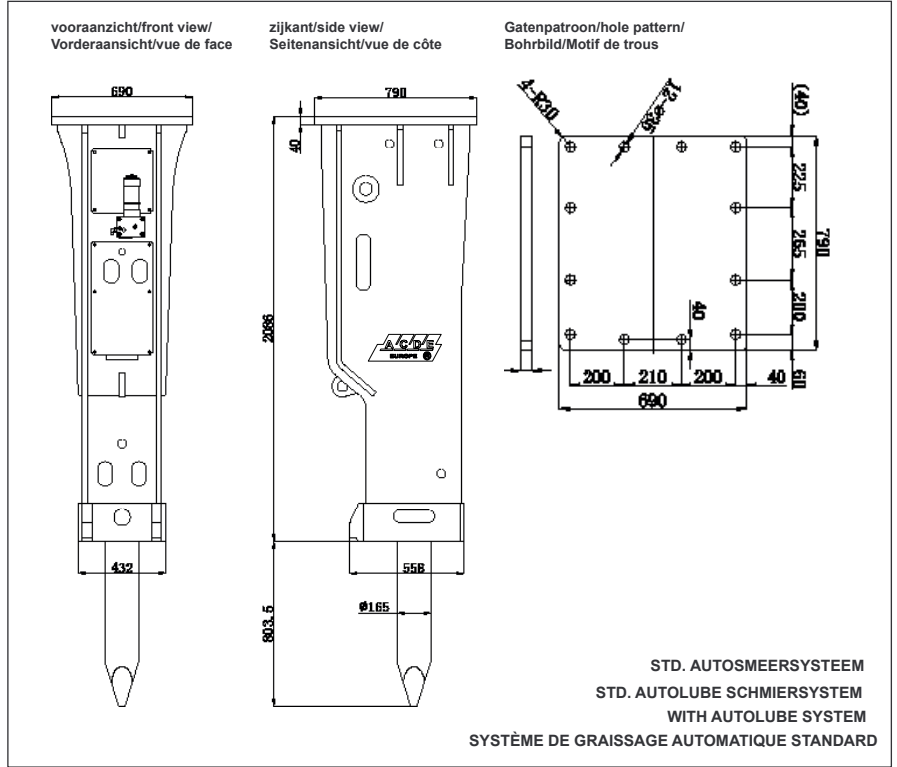

NEDERLANDS 	DEUTSCH 	ENGLISH 	FRANÇAIS 		ASB-155
WERKGEWICHT	BETRIEBSGEWICHT	WORKING WEIGHT	POIDS EN ORDRE DE MARCHÉ	kg	2320
SLAGWERK LENGTE	SCHLAGWERKLÄNGE	CYLINDER LENGHT	LONGUEUR SYSTÈME DE FRAPPE	mm	1843
TOTALE LENGTE	TOTAL LÄNGE	TOTAL LENGTH	LONGUEUR TOTALE	mm	2704
OLIE DEBIET	ÖLMENGE	REQUURED OIL FLOW	DÉBIT D'HUILE	l/min	180 - 240
WERKDRUK	BETRIEBSDRUCK	WORKING PRESSURE	PRESSION DE TRAVAIL	kg/cm ²	160 - 180
SLAGEN PER MINUUT	SCHLAGFREQUENZ	IMPACT RATE	COUPS / MINUTE	bpm	300 - 450
BEITEL DIAMETER	WERKZEUGDURCHMESSER	CHISEL DIA	DIAMÈTRE D'OUTIL	mm	Ø155
BEITEL LENGTE	MEISSEL LÄNGE	CHISEL LENGHT	LONGUEUR D'OUTIL	mm	1400
SLANG AANSLUITING	SCHLAUCH ANSCHLUSS	HOSE DIA	CONNECTION TUYAUX	inch	1 1/4
ZUIGERACCUMULATOR DRUK	KOLBENSPEICHER DRUCK	BACK HEAD PRESSURE	PRESSION PISTON ACCUMULATEUR	kg/cm ²	17 - 20
ACCUMULATOR DRUK	AKKUMULATOR DRUCK	ACCUMULATOR PRESSURE	PRESSION ACCUMULATEUR	kg/cm ²	55 - 60
GRAAFMACHINE KLASSE	BAGGERGRÖSSE	APPLICABLE EXCAVATOR	ENGIN PORTEUR CLASSE	ton	27 - 33
SLAGKRACHT	SCHLAGENERGIE	IMPACT POWER	FORCE D'IMPACT	J	5730

ACDE ASB-165

 **Hydraulische Hamer**  **Hydrauliek Hammer**
 **Hydraulic Breaker**  **Marteaux Hydrauliques**



Technical specifications 01/2018



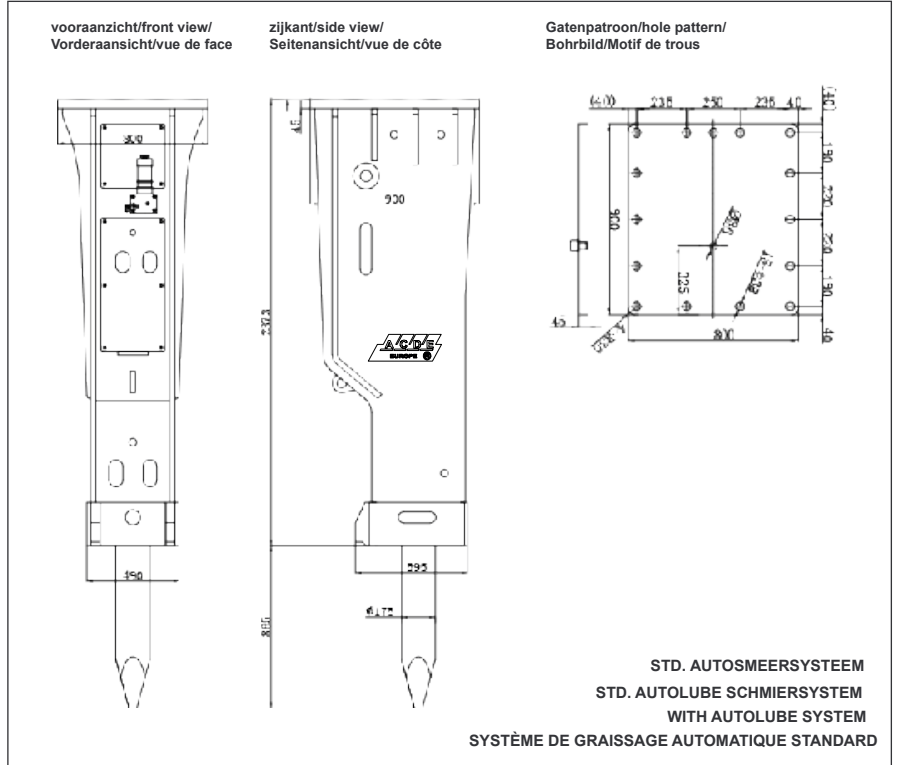

NEDERLANDS 	DEUTSCH 	ENGLISH 	FRANÇAIS 		ASB-165
WERKGEWICHT	BETRIEBSGEWICHT	WORKING WEIGHT	POIDS EN ORDRE DE MARCHÉ	kg	2570
SLAGWERK LENGTE	SCHLAGWERKLÄNGE	CYLINDER LENGHT	LONGUEUR SYSTÈME DE FRAPPE	mm	1980
TOTALE LENGTE	TOTAL LÄNGE	TOTAL LENGTH	LONGUEUR TOTALE	mm	2910
OLIE DEBIET	ÖLMENGE	REQUURED OIL FLOW	DÉBIT D'HUILE	l/min	200 - 260
WERKDRUK	BETRIEBSDRUCK	WORKING PRESSURE	PRESSION DE TRAVAIL	kg/cm ²	160 - 180
SLAGEN PER MINUUT	SCHLAGFREQUENZ	IMPACT RATE	COUPS / MINUTE	bpm	250 - 400
BEITEL DIAMETER	WERKZEUGDURCHMESSER	CHISEL DIA	DIAMÈTRE D'OUTIL	mm	Ø165
BEITEL LENGTE	MEISSEL LÄNGE	CHISEL LENGHT	LONGUEUR D'OUTIL	mm	1500
SLANG AANSLUITING	SCHLAUCH ANSCHLUSS	HOSE DIA	CONNECTION TUYAUX	inch	1 1/4
ZUIGERACCUMULATOR DRUK	KOLBENSPEICHER DRUCK	BACK HEAD PRESSURE	PRESSION PISTON ACCUMULATEUR	kg/cm ²	17 - 20
ACCUMULATOR DRUK	AKKUMULATOR DRUCK	ACCUMULATOR PRESSURE	PRESSION ACCUMULATEUR	kg/cm ²	55 - 60
GRAAFMACHINE KLASSE	BAGGERGRÖSSE	APPLICABLE EXCAVATOR	ENGIN PORTEUR CLASSE	ton	33 - 38
SLAGKRACHT	SCHLAGENERGIE	IMPACT POWER	FORCE D'IMPACT	J	6830

ACDE ASB-175 L

 **Hydraulische Hamer**  **Hydrauliek Hammer**
 **Hydraulic Breaker**  **Marteaux Hydrauliques**



Technical specifications 01/2018

NEDERLANDS 	DEUTSCH 	ENGLISH 	FRANÇAIS 		ASB-175 L
WERKGEWICHT	BETRIEBSGEWICHT	WORKING WEIGHT	POIDS EN ORDRE DE MARCHÉ	kg	4050
SLAGWERK LENGTE	SCHLAGWERKLÄNGE	CYLINDER LENGHT	LONGUEUR SYSTÈME DE FRAPPE	mm	2260
TOTALE LENGTE	TOTAL LÄNGE	TOTAL LENGTH	LONGUEUR TOTALE	mm	3154
OLIE DEBIET	ÖLMENGE	REQUURED OIL FLOW	DÉBIT D'HUILE	l/min	220 - 300
WERKDRUK	BETRIEBSDRUCK	WORKING PRESSURE	PRESSION DE TRAVAIL	kg/cm ²	160 - 180
SLAGEN PER MINUUT	SCHLAGFREQUENZ	IMPACT RATE	COUPS / MINUTE	bpm	250 - 300
BEITEL DIAMETER	WERKZEUGDURCHMESSER	CHISEL DIA	DIAMÈTRE D'OUTIL	mm	Ø175
BEITEL LENGTE	MEISSEL LÄNGE	CHISEL LENGHT	LONGUEUR D'OUTIL	mm	1600
SLANG AANSLUITING	SCHLAUCH ANSCHLUSS	HOSE DIA	CONNECTION TUYAUX	inch	1 1/4
ZUIGERACCUMULATOR DRUK	KOLBENSPEICHER DRUCK	BACK HEAD PRESSURE	PRESSION PISTON ACCUMULATEUR	kg/cm ²	22 - 25
ACCUMULATOR DRUK	AKKUMULATOR DRUCK	ACCUMULATOR PRESSURE	PRESSION ACCUMULATEUR	kg/cm ²	55 - 60
GRAAFMACHINE KLASSE	BAGGERGRÖSSE	APPLICABLE EXCAVATOR	ENGIN PORTEUR CLASSE	ton	40 - 50
SLAGKRACHT	SCHLAGENERGIE	IMPACT POWER	FORCE D'IMPACT	J	14000



ACDE EUROPE B.V.

Frans Halsstraat 5

6901DC Zevenaar

The Netherlands

Phone +31 316 26 72 91

Mobile +31 6 53 150 283

E-mail info@acde-europe.com

Web www.acde-europe.com

COPYRIGHT© 2019, ACDE EUROPE BV,