



Sun StorageTek™ 4 Gb FC NEM 20-Port Host Bus Adapter User's Guide

For HBA Model SG-XPCIE20FC-NEM-Z

Sun Microsystems, Inc.
www.sun.com

Part No. 819-7929-12
February 2008, Revision A

Submit comments about this document at: <http://www.sun.com/hwdocs/feedback>

Copyright 2008 Sun Microsystems, Inc., 4150 Network Circle, Santa Clara, California 95054, U.S.A. All rights reserved.

Sun Microsystems, Inc. has intellectual property rights relating to technology that is described in this document. In particular, and without limitation, these intellectual property rights may include one or more of the U.S. patents listed at <http://www.sun.com/patents> and one or more additional patents or pending patent applications in the U.S. and in other countries.

This document and the product to which it pertains are distributed under licenses restricting their use, copying, distribution, and decompilation. No part of the product or of this document may be reproduced in any form by any means without prior written authorization of Sun and its licensors, if any.

Third-party software, including font technology, is copyrighted and licensed from Sun suppliers.

Parts of the product may be derived from Berkeley BSD systems, licensed from the University of California. UNIX is a registered trademark in the U.S. and in other countries, exclusively licensed through X/Open Company, Ltd.

Sun, Sun Microsystems, the Sun logo, Java, AnswerBook2, docs.sun.com, StorEdge, Java, Sun Blade, SunVTS, StorageTek, FlexLine, and Solaris are trademarks or registered trademarks of Sun Microsystems, Inc. in the U.S. and in other countries.

All SPARC trademarks are used under license and are trademarks or registered trademarks of SPARC International, Inc. in the U.S. and in other countries. Products bearing SPARC trademarks are based upon an architecture developed by Sun Microsystems, Inc.

The OPEN LOOK and Sun™ Graphical User Interface was developed by Sun Microsystems, Inc. for its users and licensees. Sun acknowledges the pioneering efforts of Xerox in researching and developing the concept of visual or graphical user interfaces for the computer industry. Sun holds a non-exclusive license from Xerox to the Xerox Graphical User Interface, which license also covers Sun's licensees who implement OPEN LOOK GUIs and otherwise comply with Sun's written license agreements.

U.S. Government Rights—Commercial use. Government users are subject to the Sun Microsystems, Inc. standard license agreement and applicable provisions of the FAR and its supplements.

DOCUMENTATION IS PROVIDED "AS IS" AND ALL EXPRESS OR IMPLIED CONDITIONS, REPRESENTATIONS AND WARRANTIES, INCLUDING ANY IMPLIED WARRANTY OF MERCHANTABILITY, FITNESS FOR A PARTICULAR PURPOSE OR NON-INFRINGEMENT, ARE DISCLAIMED, EXCEPT TO THE EXTENT THAT SUCH DISCLAIMERS ARE HELD TO BE LEGALLY INVALID.

Copyright 2008 Sun Microsystems, Inc., 4150 Network Circle, Santa Clara, Californie 95054, États-Unis. Tous droits réservés.

Sun Microsystems, Inc. possède les droits de propriété intellectuelle relatifs à la technologie décrite dans ce document. En particulier, et sans limitation, ces droits de propriété intellectuelle peuvent inclure un ou plusieurs des brevets américains listés sur le site <http://www.sun.com/patents>, un ou les plusieurs brevets supplémentaires ainsi que les demandes de brevet en attente aux États-Unis et dans d'autres pays.

Ce document et le produit auquel il se rapporte sont protégés par un copyright et distribués sous licences, celles-ci en restreignent l'utilisation, la copie, la distribution, et la décompilation. Aucune partie de ce produit ou document ne peut être reproduite sous aucune forme, par quelque moyen que ce soit, sans l'autorisation préalable et écrite de Sun et de ses bailleurs de licence, s'il y en a.

Tout logiciel tiers, sa technologie relative aux polices de caractères, comprise, est protégé par un copyright et licencié par des fournisseurs de Sun.

Des parties de ce produit peuvent dériver des systèmes Berkeley BSD licenciés par l'Université de Californie. UNIX est une marque déposée aux États-Unis et dans d'autres pays, licenciée exclusivement par X/Open Company, Ltd.

Sun, Sun Microsystems, le logo Sun, Java, AnswerBook2, docs.sun.com, StorEdge, Java, Sun Blade, SunVTS, StorageTek, FlexLine, et Solaris sont des marques de fabrique ou des marques déposées de Sun Microsystems, Inc. aux États-Unis et dans d'autres pays.

Toutes les marques SPARC sont utilisées sous licence et sont des marques de fabrique ou des marques déposées de SPARC International, Inc. aux États-Unis et dans d'autres pays. Les produits portant les marques SPARC sont basés sur une architecture développée par Sun Microsystems, Inc.

L'interface utilisateur graphique OPEN LOOK et Sun™ a été développée par Sun Microsystems, Inc. pour ses utilisateurs et licenciés. Sun reconnaît les efforts de pionniers de Xerox dans la recherche et le développement du concept des interfaces utilisateur visuelles ou graphiques pour l'industrie informatique. Sun détient une licence non exclusive de Xerox sur l'interface utilisateur graphique Xerox, cette licence couvrant également les licenciés de Sun implémentant les interfaces utilisateur graphiques OPEN LOOK et se conforment en outre aux licences écrites de Sun.

LA DOCUMENTATION EST FOURNIE "EN L'ÉTAT" ET TOUTES AUTRES CONDITIONS, DÉCLARATIONS ET GARANTIES EXPRESSES OU TACITES SONT FORMELLEMENT EXCLUES DANS LA LIMITE DE LA LOI APPLICABLE, Y COMPRIS NOTAMMENT TOUTE GARANTIE IMPLICITE RELATIVE À LA QUALITÉ MARCHANDE, À L'APTITUDE À UNE UTILISATION PARTICULIÈRE OU À L'ABSENCE DE CONTREFAÇON.



Contents

Preface xi

- 1. Network Express Module Overview** 1
 - NEM Features and Specifications 1
 - ID Chip Feature 3
 - Operating System Requirements 4
 - System Interoperability 4
 - Host Platform Support 5
 - Storage System Support 5
 - Fibre Channel Switch Support 6

- 2. Hardware Installation and Removal** 7
 - Observing ESD and Handling Precautions 8
 - Installing the NEM 8
 - ▼ To Install the NEM 9
 - ▼ To Connect the Optical Cables 11
 - Configuring the NEM For Hot-Plug Operation 14
 - Using the ILOM Web Interface 14
 - Using the ILOM Command-Line Interface 15
 - Verifying a Hot-Insert Operation 16

Using the ILOM Web Interface	16
Using the ILOM CLI	17
▼ To Verify NEM Status	17
Replacing a NEM	19
▼ To Install the ID Chip Patch	19
▼ To Remove a NEM	19
▼ To Replace the ID Chip	20
3. HBA Software Installation	23
Driver Software for the Solaris OS	23
Solaris Diagnostic Support	23
Driver Software for Linux OSs	24
Red Hat Enterprise Linux	24
Novell SUSE Linux Enterprise Server	24
▼ To Update the Driver	24
▼ To Install SLES9-SP3 to FC Disk	25
▼ To Build the Linux 2.6 Driver	25
Driver Software for Windows 2003 OS	26
▼ To Install Windows OS Driver and Application Kits	26
Configuration and Diagnostic Utilities	26
4. Release Notes	29
Using the NEM With Sun StorEdge 3510 and 3511 Arrays	29
Solaris OS-Specific Issues	30
Out of Option ROM Memory Error in System BIOS	30
SUSE Linux Enterprise-Specific Issues	30
Windows Server 2003 OS-Specific Issues	30
A. Declaration of Conformity, Regulatory Compliance, and Safety Statements	31

Declaration of Conformity	33
Safety Agency Compliance Statement	35
Regulatory Compliance Statements	47
Index	51

Figures

- FIGURE 2-1 NEM Ejector Levers 9
- FIGURE 2-2 Inserting the NEM Into the Chassis 10
- FIGURE 2-3 Connecting the Optical Cables 12
- FIGURE 2-4 Port Level LEDs 13
- FIGURE 2-5 LEDs, Attention and Locator Buttons 18
- FIGURE 2-6 Location of ID Chip 20
- FIGURE 2-7 Installing the ID Chip 21

Tables

TABLE 1-1	NEM Features and Specifications	2
TABLE 1-2	Supported Operating System Versions	4
TABLE 1-3	Platform and Operating System Support	5
TABLE 2-1	Optical Cable Specifications	11
TABLE 2-2	Port LED Indicator Status Definitions	13
TABLE 2-3	NEM LED Status	18

Preface

This guide describes how to install and remove the Sun StorageTek™ 4 Gb Fibre Channel (FC) Network Express Module (NEM) Host Bus Adapter (HBA), 20-port pass-through RoHS 5 compliant module. This document is written for technicians, system administrators, application service providers (ASPs), and users who have advanced experience troubleshooting and replacing hardware.

How This Document Is Organized

[Chapter 1](#) provides an overview of the product and lists the various operating systems, host platforms, switches, and storage systems that support the NEM.

[Chapter 2](#) describes how to install and remove the NEM.

[Chapter 3](#) describes how to download and install the HBA drivers and patches.

[Chapter 4](#) contains the latest supplementary information for the preceding chapters.

[Appendix A](#) provides the required product safety information.

Using UNIX Commands

This document might not contain information about basic UNIX® commands and procedures such as shutting down the system, booting the system, and configuring devices. Refer to the following for this information:

- Software documentation that you received with your system
- Solaris™ Operating System documentation, which is at:

<http://docs.sun.com>

Shell Prompts

Shell	Prompt
C shell	<i>machine-name%</i>
C shell superuser	<i>machine-name#</i>
Bourne shell and Korn shell	\$
Bourne shell and Korn shell superuser	#

Typographic Conventions

Typeface*	Meaning	Examples
AaBbCc123	The names of commands, files, and directories; on-screen computer output	Edit your <code>.login</code> file. Use <code>ls -a</code> to list all files. % You have mail.
AaBbCc123	What you type, when contrasted with on-screen computer output	% su Password:
<i>AaBbCc123</i>	Book titles, new words or terms, words to be emphasized. Replace command-line variables with real names or values.	Read Chapter 6 in the <i>User's Guide</i> . These are called <i>class</i> options. You <i>must</i> be superuser to do this. To delete a file, type <code>rm filename</code> .

* The settings on your browser might differ from these settings.

Related Documentation

The documents listed are available at:

<http://www.sun.com/documentation/>

Title	Part Number
<i>Solaris Fibre Channel and Storage Multipathing Administration Guide</i>	819-0139- <i>nn</i>
<i>Sun Blade 8000 Series Installation Guide</i>	819-5647- <i>nn</i>
<i>Sun Blade 8000 Series Product Notes</i>	819-5651- <i>nn</i>
<i>Sun Blade 8000 Series Online Help System</i>	819-5846- <i>nn</i>

Documentation, Support, and Training

Sun Function	URL
Documentation	http://www.sun.com/documentation/
Support	http://www.sun.com/support/
Training	http://www.sun.com/training/

Third-Party Web Sites

Sun is not responsible for the availability of third-party web sites mentioned in this document. Sun does not endorse and is not responsible or liable for any content, advertising, products, or other materials that are available on or through such sites or resources. Sun will not be responsible or liable for any actual or alleged damage or loss caused by or in connection with the use of or reliance on any such content, goods, or services that are available on or through such sites or resources.

Sun Welcomes Your Comments

Sun is interested in improving its documentation and welcomes your comments and suggestions. You can submit your comments by going to:

<http://www.sun.com/hwdocs/feedback>

Please include the title and part number of your document with your feedback:

Sun StorageTek 4 Gb FC NEM 20-Port Host Bus Adapter User's Guide, part number 819-7929-12

Service Contact Information

If you need help installing or using this product, call 1-800-USA-4SUN, or go to:

<http://www.sun.com/service/contacting/>

Network Express Module Overview

This chapter provides a basic overview of the Sun StorageTek™ 4 Gb Fibre Channel (FC) Network Express Module (NEM) Host Bus Adapter (HBA). This chapter also describes the various operating systems, host platforms, storage, and infrastructure configurations that support the NEM. This chapter contains the following topics:

- [“NEM Features and Specifications” on page 1](#)
- [“Operating System Requirements” on page 4](#)
- [“System Interoperability” on page 4](#)

NEM Features and Specifications

The Sun StorageTek 4 Gb FC NEM 20-Port HBA consists of a 20-port NEM bus expansion board that interfaces a FC optical media bus. The NEM provides closed chassis adapter installation, removal, integrated hot-plug, and protection from electrostatic discharge (ESD) handling damage.

The 20-port NEM consists of ten independent HBAs. Each HBA has two FC ports which provide exclusive connections to a single blade. The ports of each HBA cannot be shared with any other blade in the chassis.

The NEM supports 20 independent FC buses operating at 4.25 Gbits/sec. It is also backward compatible with 2.125-Gbit/sec and 1.0625-Gbit/sec devices. Small-Form Factor (SFF) optical transceivers are used to connect to the external FC buses.

Twenty SFP fiber-optic transceivers are included with each NEM. You can order additional NEMs and SFP transceivers from Sun Microsystems using the following part numbers:

Description	Part Number
4 Gb FC NEM 20-port HBA	SG-XPCIE20FC-NEM-Z
4 pack of Small-Form Pluggable shortwave FC optical transceivers capable of 4 Gb, 2 Gb, and 1 Gb transfer rates (RoHS-5 compliant)	XSFP-SW-4GB-4PK
Small-Form Pluggable shortwave FC optical transceiver capable of 4 Gb, 2 Gb, and 1 Gb transfer rates (RoHS-5 compliant)	XSFP-SW-4GB

See [TABLE 1-1](#) for a list of the NEM's features.

TABLE 1-1 NEM Features and Specifications

Feature	Description
NEM interface	PCI Express ten x8 (ten x4 active links)
FC interface	Dual port 4, 2, 1 Gbps auto-speed negotiation
FC topology	Point-to-point (N_port), Arbitrated Loop (NL_port) and Switched Fabric (N_port)
PCI transfer rate (maximum)	PCI Express Generation One (2.5 Gbps) x4
Onboard memory	One 4-MB flash ROM per chip, 40 MB total, field-programmable One 1.5 MB SRAM per chip, 15 MB total NEM SRAM
ID chip	Enables the HBA worldwide names (WWNs) to be retained when a NEM is replaced. See "ID Chip Feature" on page 3 for more information.
External FC connectors	Small Form-Factor Pluggable (SFP) multimode optic with LC-style connector
Maximum FC cable length	1 Gbps: 500 meters using 50/125 μ m core fiber 300 meters using 62.5/125 μ m core fiber 2 Gbps: 300 meters using 50/125 μ m core fiber 150 meters using 62.5/125 μ m core fiber 4 Gbps: 150 meters using 50/125 μ m core fiber 70 meters using 62.5/125 μ m core fiber

TABLE 1-1 NEM Features and Specifications (*Continued*)

Feature	Description
LED indicators	A blue (Ready to Remove), yellow (Service Action Required) and green (Power, Attention, and Connected) LED on the front panel. Two LEDs per channel (green and yellow) on the front panel used to indicate port status.
Buttons	Attention button to support hot-swap functionality. Locator button to assist in locating the module. (See FIGURE 2-5 for button locations.)
Form Factor	PCI Network Express Module

ID Chip Feature

The 20-port NEM has an ID chip on it that contains an Electrically Erasable Read Only Memory (EEPROM). This EEPROM stores the worldwide names (WWNs) for each of the ten HBAs and 20 FC ports on the NEM.

When you replace a failed NEM that is running firmware prior to version 2.72a, each of the ten HBAs and 20 FC ports on the NEM is assigned new port and node WWNs. Thus, you must update SAN components, such as FC switches and storage arrays, with the new WWN values.

However, if the failed NEM is running firmware version 2.72a, at minimum, you can retain the existing HBA and FC port WWNs by removing the ID chip from the failed NEM and installing the chip on the replacement NEM. Thus, you do not have to update any SAN components as part of the NEM replacement. In order for the ID chip feature to work, the replacement NEM must be running firmware version 2.72a, at minimum.

For information about determining and updating the firmware version, see the following Emulex documents:

- Solaris: http://www.emulex.com/support/solaris/sfs_100/manual.pdf#P4

Note – For the Solaris OS, the 2.72a firmware is embedded in the emlxs driver version 2.21g, at minimum. This driver is part of s10u5 and available as Solaris 10 patch 120223-22 or 120222-22 at: <http://sunsolve.sun.com>

- Linux: www-dl.emulex.com/support/linux/81103/pdf/manual.pdf

- Windows: www-dl.emulex.com/support/windows/storport/130a9/manual.pdf

If you replace the failed NEM (regardless of firmware version) and do not swap the ID chip, new WWNs are assigned to each of the ten HBAs and 20 FC ports; thus, requiring you to update SAN components with the new WWN values.

For more information about replacing a failed NEM, see “[Replacing a NEM](#)” on [page 19](#).

Operating System Requirements

The NEM requires the operating system (OS) levels listed in [TABLE 1-2](#).

TABLE 1-2 Supported Operating System Versions

Operating System	Supported Versions
Solaris (x64)	Solaris 10 11/06, Solaris 10 06/06, or Solaris 10 01/06 and latest patches* 119131, 120222, and 120223 Solaris 10, latest patches 119255, 119131, 120222, and 120223 plus packages \ SUNWem1xs and SUNWem1xu
Linux	Red Hat Enterprise Linux (RHEL) 4 Update 3 and Update 4 x64 SUSE Linux Enterprise Server (SLES) 9 SP3 x64
Microsoft Windows	Windows Server 2003 Enterprise Edition x64 Windows Server 2003 Enterprise Edition x86 w/SP1 Windows Server 2003 Standard Edition x86 w/SP1

* Patches are available at <http://sunsolve.sun.com>.

\ Packages are available for download at: the Sun Download Center (SDLC).

System Interoperability

This section provides information about selected platforms, storage systems, and switches that are compatible with the heterogeneous FC network design of the NEM. This section contains the following topics:

- “[Host Platform Support](#)” on [page 5](#)
- “[Storage System Support](#)” on [page 5](#)

- “Fibre Channel Switch Support” on page 6

Host Platform Support

The NEM is supported by the platforms and operating systems (OSs) listed in [TABLE 1-3](#).

TABLE 1-3 Platform and Operating System Support

Platform	Supported OSs
Sun Blade™ 8000 Modular System	Sun Solaris, Linux, and Windows
Sun Blade 8000 P Modular System	Sun Solaris, Linux, and Windows

You can install the NEM in an available NEM slot of the Sun Blade 8000 Chassis or Sun Blade 8000 P chassis.

For information about updating the ILOM firmware for the chassis monitoring module (CMM) or the service processor (SP) go to <http://www.sun.com/servers/blades/8000/downloads.jsp>. For firmware upgrade instructions, see *Preparing to Upgrade the ILOM Firmware in the Sun Blade 8000 Series Online Information System*.

Storage System Support

The NEM supports the following storage systems:

- Sun StorEdge™ 3510 and 3511 FC Arrays (see [“Using the NEM With Sun StorEdge 3510 and 3511 Arrays” on page 29](#))
- Sun StorEdge 6020 and 6120 Arrays
- Sun StorEdge 6130 Array
- Sun StorageTek 6140 Array
- Sun StorageTek 6540 Array
- Sun StorageTek FlexLine™ 380 Storage System
- Sun StorEdge 6320 system
- Sun StorEdge L25 and L100 tape libraries with Fibre Channel / LVD Internal Bridge
- Sun StorEdge C4 tape library with LVD SCSI to Fibre Channel Card
- Sun StorEdge L500 tape library
- Sun StorEdge L180, L700 tape libraries

- Sun StorEdge L5500, L8500 tape libraries

Fibre Channel Switch Support

The NEM is supported with the following FC switches:

- 2 Gb QLogic SANbox 5200 switch
- 4 Gb QLogic SANbox 5600 and 5602 Stackable FC switches
- 2 Gb Brocade SilkWorm 3200 and 3800 switches
- 2 Gb Brocade SilkWorm 3250 and 3850 switches
- 2 Gb Brocade SilkWorm 3900 switch
- 2 Gb Brocade SilkWorm 12000 and 24000 directors
- 4 Gb Brocade SilkWorm 4100 switch
- 4 Gb Brocade SilkWorm 4900 switch
- 4 Gb Brocade SilkWorm 48000 and 200E
- 2 Gb McDATA Sphereon 4300 switch
- 2 Gb McDATA Sphereon 4500 switch
- 4 Gb McDATA Sphereon 4400 and 4700 switches
- 2 Gb McDATA Intrepid 6064 director
- 2 Gb McDATA Intrepid 6140 director
- 2 Gb McDATA Intrepid i10K director

Hardware Installation and Removal

This chapter describes the tasks required to install and remove the NEM when the Sun Blade 8000 Modular System is in a powered-on state.

Note – If you are powering on the Sun Blade 8000 Modular System or Sun Blade 8000 P Modular System for the first time, follow the installation instructions in the *Sun Blade 8000 Series Installation Guide*.

This chapter contains the following topics:

- “Observing ESD and Handling Precautions” on page 8
- “Installing the NEM” on page 8
- “Configuring the NEM For Hot-Plug Operation” on page 14
- “Verifying a Hot-Insert Operation” on page 16
- “Replacing a NEM” on page 19

Observing ESD and Handling Precautions



Caution – Damage to the NEM can occur as the result of careless handling or electrostatic discharge (ESD). Always handle the NEM with care to avoid damage to electrostatic sensitive components.

To minimize the possibility of ESD-related damage, Sun strongly recommends using both a workstation antistatic mat and an ESD wrist strap. You can get an ESD wrist strap from any reputable electronics store or from Sun as part number #250-1007. Observe the following precautions to avoid ESD-related problems:

- Leave the NEM in its antistatic bag until you are ready to install it in the system.
- Always use a properly fitted and grounded wrist strap or other suitable ES protection when handling the NEM and observe proper ESD grounding techniques.
- Place the NEM on a properly grounded antistatic work surface pad when it is out of its protective antistatic bag.

Installing the NEM

This section describes the process for installing a new Network Express Module (NEM) in a *powered-on* Sun Blade 8000 or Sun Blade 8000 P system.

Note – If you are installing the NEM in a *new* Sun Blade 8000 or Sun Blade 8000 P system that has not yet been powered on, follow the installation instructions in the *Sun Blade 8000 Series Installation Guide*.

- [To Install the NEM](#)
- [To Connect the Optical Cables](#)

The following sections describe these steps in more detail.

▼ To Install the NEM

1. **Attach an antistatic strap** (refer to [“Observing ESD and Handling Precautions”](#) on page 8).
2. **Refer to your system installation or service manual to determine an appropriate slot in which to install the NEM.**
3. **Unpack the NEM and remove it from the antistatic bag.**
4. **Locate a vacant NEM slot in the back of the chassis. Ensure the label on top of the NEM is facing up.**
5. **Align the NEM with the vacant slot.**

Ensure that the NEM’s port connectors are facing toward you and that the NEM ejector levers are fully opened.

FIGURE 2-1 NEM Ejector Levers

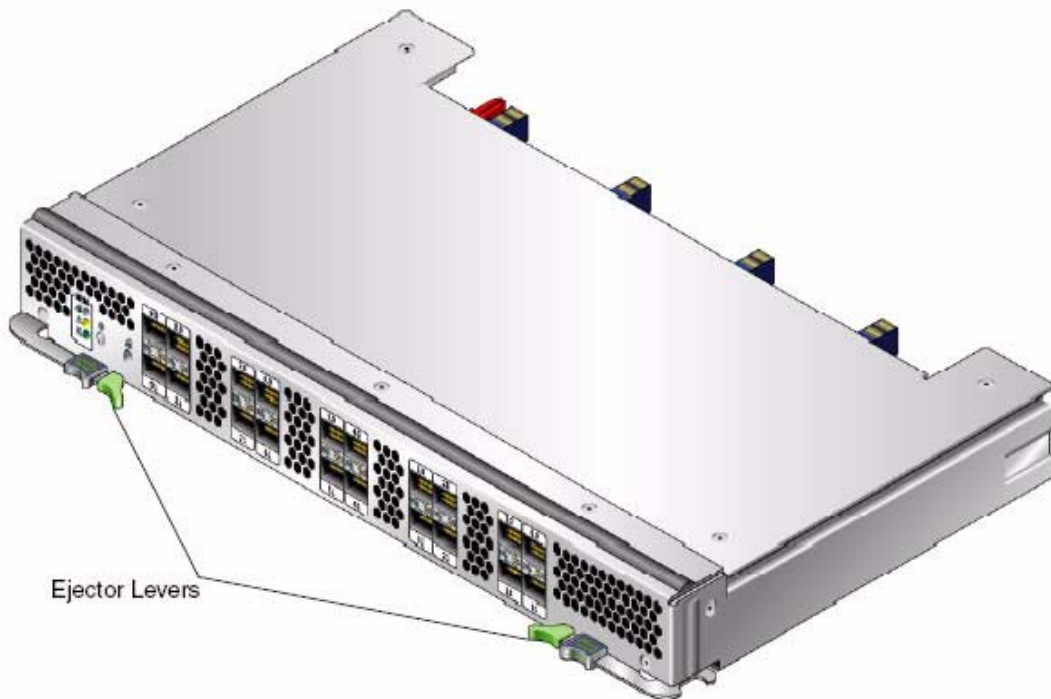

6. **Align the NEM with the chassis guidance system and slide the NEM into its slot (see [FIGURE 2-2](#)).**

Ensure that the NEM engages with the system chassis guidance system. Failure to align the NEM correctly can result in damage with the internal connection to the chassis midplane.

FIGURE 2-2 Inserting the NEM Into the Chassis

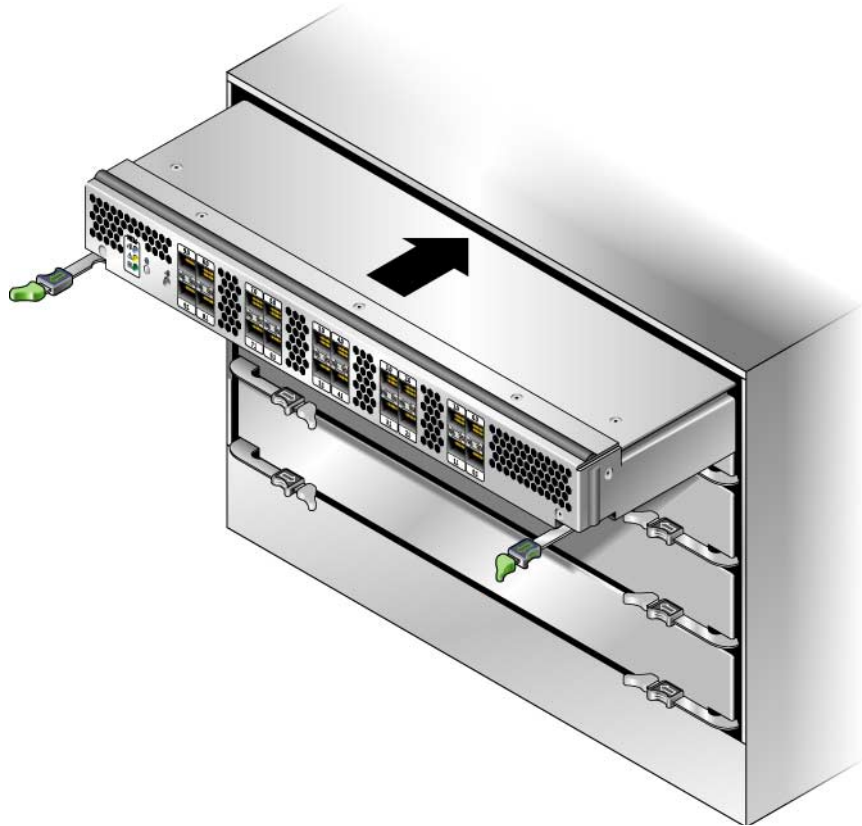

7. **Push the ejector levers toward each other and close the levers to secure the NEM in its slot.**
After you physically install the NEM in its slot, the Chassis Monitoring Module (CMM) will automatically detect the presence of the NEM. The OK LED goes to Standby blink (see [TABLE 2-3](#) for LED status).
8. **Press the Attention button to notify the blades (host operating systems) of the presence of the NEM.**
9. **Verify that the NEM is working properly.**
See [“To Verify NEM Status”](#) on page 17.

▼ To Connect the Optical Cables

Note – The NEM does not allow normal data transmission on an optical link unless it is connected to another similar or compatible Fibre Channel (FC) product (that is, multimode to multimode).

Use multimode fiber-optic cable, intended for short-wave lasers, that adheres to the specifications in [TABLE 2-1](#).

TABLE 2-1 Optical Cable Specifications

Fiber-Optic Cable	Maximum Length	Minimum Length	Connector
62.5/125 μm (multimode)	300 meters at 1.0625 Gbps	2 meters	LC
	150 meters at 2.125 Gbps		
	70 meters at 4.25 Gbps		
50/125 μm (multimode)	500 meters at 1.0625 Gbps	2 meters	LC
	300 meters at 2.125 Gbps		
	150 meters at 4.25 Gbps		

Follow these steps when connecting the optical cables:

1. Connect each fiber-optic cable to an LC connector on the NEM (see [FIGURE 2-3](#)).

The ports are numbered 0-9 right-to-left as viewed from the back of the chassis. Each NIC has two external network ports. For each pair of external ports (for each blade), the top is port 0 and the bottom is port 1.

FIGURE 2-3 Connecting the Optical Cables

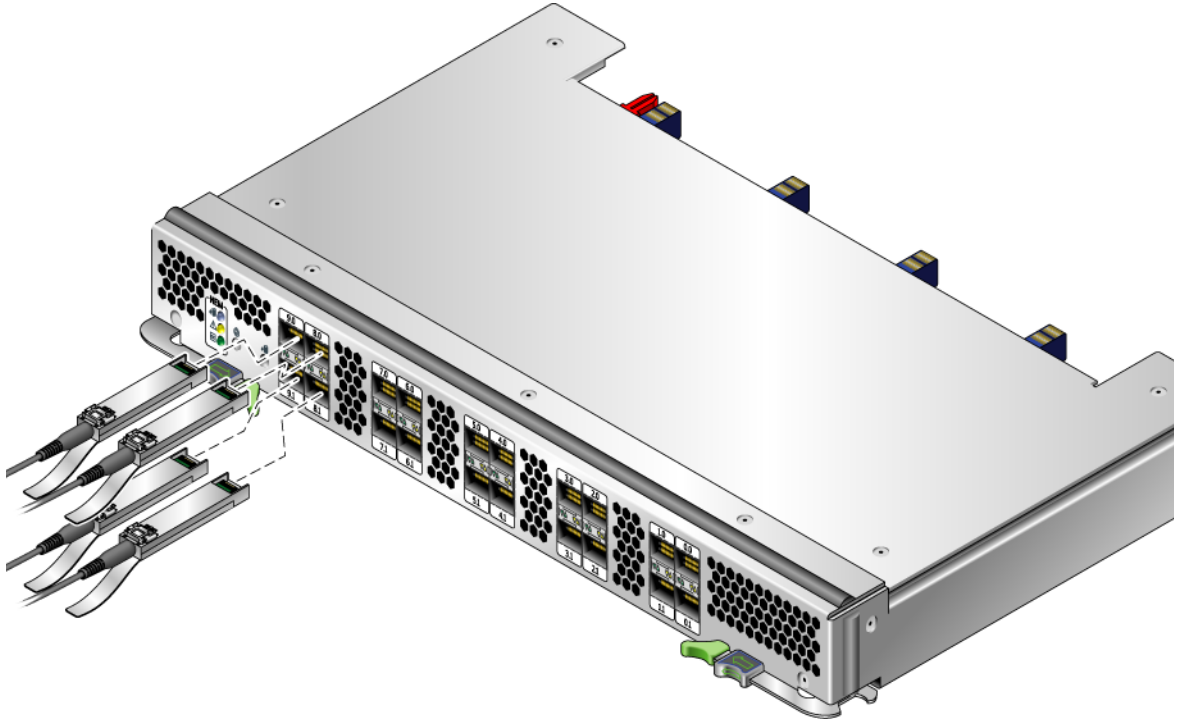

2. Connect the other end of each cable to a FC device.

After the optical cables are connected to the NEM, proceed to [“Configuring the NEM For Hot-Plug Operation”](#) on page 14.

3. Observe the light-emitting diodes (LEDs) status for the power-on self test (POST).

Each port has a corresponding set of LEDs that provide a visual indication of the operating state. See [FIGURE 2-4](#) to determine the location of the port LEDs.

FIGURE 2-4 Port Level LEDs

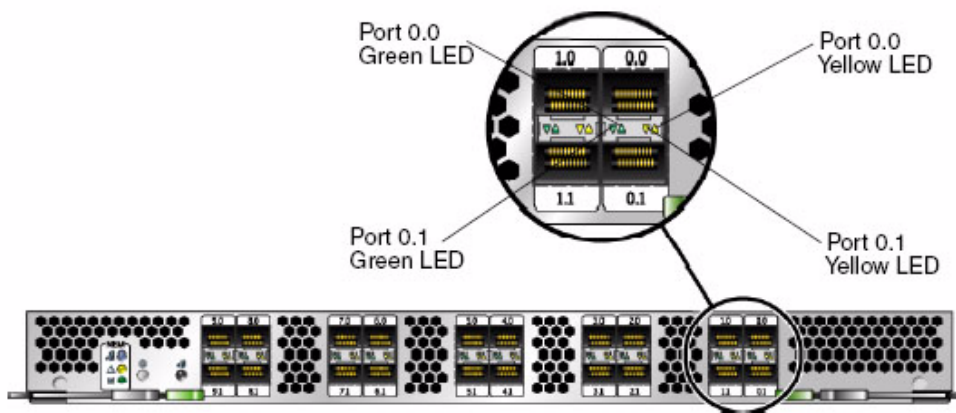

TABLE 2-2 summarizes port LED indicator combinations.

TABLE 2-2 Port LED Indicator Status Definitions

Green LED	Yellow LED	State
On	1 Fast blink	1-Gb Link Rate - Normal operating state, link up
On	2 Fast blinks	2-Gb Link Rate - Normal operating state, link up
On	3 Fast blinks	4-Gb Link Rate - Normal operating state, link up
Off	Off	Wake-up failure (board failed)
Off	On	POST failure (board failed)
Off	Slow blink	Wake-up failure monitor
Off	Fast blink	Failure in POST
Off	Flashing	POST processing in progress
On	Off	Failure while functioning
On	On	Failure while functioning
Slow blink	Off	Normal, link down
Slow blink	On	Not defined
Slow blink	Slow blink	Off-line for download
Slow blink	Fast blink	Restricted off-line mode (waiting for restart)
Slow blink	Flashing	Restricted off-line mode, test active

Configuring the NEM For Hot-Plug Operation

To insert a NEM into the chassis while the system is running, you need to:

1. **Physically install the module.**
2. **Prepare the NEM for hot-insertion by using the CMM integrated lights-out management (ILOM) web interface or command-line-interface (CLI) and verify the NEM has returned the expected feedback.**
See [“To Verify NEM Status” on page 17.](#)
3. **Verify in one of the ILOM interfaces that the module’s Ready to Remove status is Not Ready.**

Using the ILOM Web Interface

1. **Log in to the ILOM web interface using the IP address of the active Chassis Monitoring Module.**

The first page of the ILOM web interface is displayed.

2. **In the left navigation pane, select CMM.**

The ILOM Version Information page is displayed.

3. **Select the System Information tab, and then the Components tab.**

The Component Management page is displayed. If you have installed a new NEM, go to Step 4.

When you were preparing a NEM for a hot-remove, if you selected Prepare to Remove from the Component Management page and corrected the problem without removing the NEM or if you decided not to remove the NEM, complete Step 3a and Step 3b.

- a. **Select the radio button next to the NEM that you want to hot-insert.**

If you select the wrong NEM, click on the deselect icon at the top of the radio button column.

- b. **From the Actions drop-down list, select Return to Service.**

When you select the Return to Service option, the system recognizes the inserted NEM, changes its Ready to Remove status to Not Ready, and lights the NEM’s green OK indicator.

4. Verify that the selected NEM has returned the expected feedback.
See “To Verify NEM Status” on page 17.

Using the ILOM Command-Line Interface

1. Log in to the ILOM CLI of the active Chassis Monitoring Module.
2. For a list of components in your system, type:

```
show /CH
```

3. If you installed a new NEM, go to [Step 4](#).

When you were preparing a NEM for a hot-remove, if you corrected the problem without removing the NEM or you decided not to remove the NEM, complete the following steps:

- a. Type this command to prepare a component for a hot-insert:

```
set /CH/component return_to_service_action=true
```

For example:

```
set /CH/NEM1 return_to_service_action=true
```

- b. Use the `show /CH/component` command to list the status of the connection from the NEM to each of the blades.

Note – The following example depicts only the link status portion of the `show /CH/component` command output.

```
-> show /CH/NEM1  
blade0_link_status = Not_connected  
blade1_link_status = Not_connected  
blade2_link_status = Not_connected  
blade3_link_status = Not_connected  
blade4_link_status = Not_connected  
blade5_link_status = Not_connected  
blade6_link_status = Connected  
blade7_link_status = Not_connected  
blade8_link_status = Not_connected  
fault_state = OK  
clear_fault_action = (none)  
prepare_to_remove_status = NotReady
```

- c. If all blades that you expect to be connected show a **Connected link status**, go to [Step 4](#). Otherwise, if a blade that you expect to be connected has a link status of **Not connected**, perform [Step a](#) - [Step b](#) again until its link status is **Connected**.
4. To verify that the NEM Ready to Remove status has changed to **Not Ready**, type:

```
show /CH/component prepare_to_remove_status
```

The system returns:

```
prepare_to_remove_status = Not Ready
```
5. Verify that the selected NEM has returned the expected feedback.
See the [“To Verify NEM Status”](#) on page 17.

Verifying a Hot-Insert Operation

You can replace many components in the chassis while the system is running by using a hot-plug procedure.

To insert modules into the chassis while the system is running, you need to:

1. **Physically install the module.**
2. **Verify in one of the ILOM interfaces that the module’s Ready to Remove status is Not Ready and that the module has returned the expected feedback.**
See [“To Verify NEM Status”](#) on page 17.

You can use the ILOM web interface or ILOM CLI to verify.

Using the ILOM Web Interface

1. **Log in to the ILOM web interface using the IP address of the active Chassis Monitoring Module.**
The first page of the ILOM web interface is displayed.
2. **In the left navigation pane, select CMM (Chassis Monitoring Module).**
The ILOM Version Information page is displayed.
3. **Select the System Information tab, and then the Components tab.**
The Component Management page is displayed.

4. Verify that the selected NEM has returned the expected feedback.
See [“To Verify NEM Status” on page 17.](#)

Using the ILOM CLI

1. Log in to the ILOM CLI of the active Chassis Monitoring Module.
2. For a list of components in your system, type:
show /CH
3. To verify that the NEM Ready to Remove status has changed to Not Ready, type:
show /CH/component prepare_to_remove_status
The system returns:

```
prepare_to_remove_status = Not Ready
```
4. Verify that the selected NEM has returned the expected feedback.
See [“To Verify NEM Status” on page 17.](#)

▼ To Verify NEM Status

See [TABLE 2-3](#) for a description of the LED states for the NEM. See [FIGURE 2-5](#) for the location of the LEDs, Attention button, and Locator button.

1. Check the following LEDs to verify that the NEM is ready for a hot-plug insertion.
 - Green OK LED goes to Standby.
2. Activate the NEM by pressing the Attention button, and the green OK LED goes to Slow blink.
 - When all links to active blades have been made, the green OK LED goes to Solid On.

- Ready to Remove status shows Not Ready in the ILOM interfaces.

TABLE 2-3 NEM LED Status

Ready-to-Remove LED Color: Blue Location: Top	Service Action Required LED Color: Yellow Location: Middle	OK LED (Power, Attention, and Connected) Color: Green Location: Bottom	Status
On	Off	Off	Ready to remove
Off	On	Off	Service attention required
Off	Off	Very slow blink	Standby
Off	Off	Slow blink	Connecting links to blades
Off	Off	On	Links connected to blades

FIGURE 2-5 LEDs, Attention and Locator Buttons

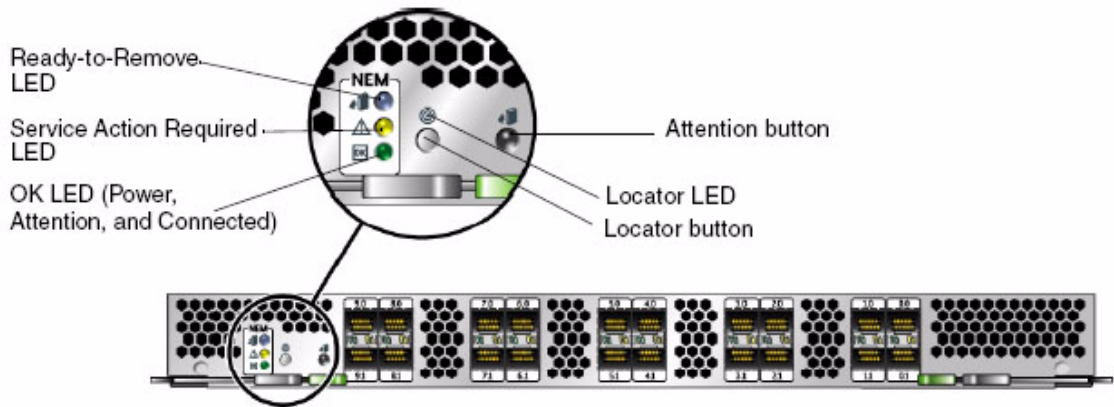

The Attention button enables you to activate (if inserting) or prepare to remove (if removing) a NEM during a hot-plug operation.

The Locator button, when pressed momentarily, flashes a white light to assist in locating the module. You can also activate the Locator LED remotely by executing a command on the CMM.

Replacing a NEM

If a NEM fails or if you choose to change the I/O configuration, you will need to replace it. You can remove and replace a NEM from a powered-on system using a hot-plug operation, as well as from a powered-off system. When you remove a NEM, you must replace the module within two minutes to prevent adjacent modules from overheating.

If you are removing but not replacing the NEM, you also must install a NEM filler panel to meet FCC limits for electromagnetic interference (EMI) and to ensure proper airflow and cooling. If you encounter a problem with the NEM replacement, see the *Sun Blade 8000 Series Online Help System* for troubleshooting steps.

▼ To Install the ID Chip Patch

1. **Download patch 120223-22 or 120222-22 from SunSolve:**

<http://sunsolve.sun.com>

2. **Install the patch onto each of the HBAs in the NEM.**

Follow the installation instructions included in the patch Readme file.

▼ To Remove a NEM

1. **Identify which NEM to replace.**

If the yellow Service Action Required LED is lit, this indicates a problem with the NEM and you might choose to replace it. Otherwise, if you want to change the I/O configuration, you can choose any NEM to replace.

2. **Prepare the NEM for a hot-plug procedure using either of these methods:**

- a. **Press the Attention button on the NEM to initiate the hot-plug removal.**

- b. **Use the ILOM web interface or the CLI to initiate the hot-plug removal.**

If the NEM fails the hot-plug preparation and its Ready-to-Remove LED does not light, see the *Sun Blade 8000 Series Online Help System* for troubleshooting steps.

3. **When the blue Ready-to-Remove LED is lit on the NEM, physically remove the NEM.**

- a. **Remove all cables from the NEM.**

- b. Press the latch on both ejector levers inward at the same time.
- c. Swing out the ejector levers to their fully open position.
- d. Slide the NEM out of its slot.
Support the weight of the NEM with one hand at the bottom of the NEM.

▼ To Replace the ID Chip

1. After you have removed the failed NEM from the chassis, locate the ID chip at the back of the board (see [FIGURE 2-6](#)).

FIGURE 2-6 Location of ID Chip

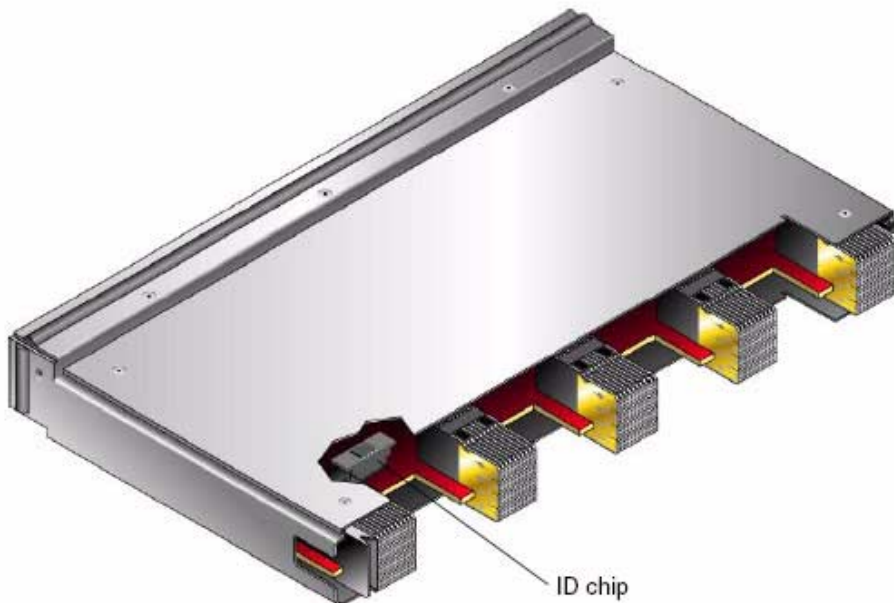

2. Grasp the edges of the ID chip and pull straight up to remove it from the board.
3. Remove the ID chip from the new NEM, and install it onto the failed board that you will be returning to Sun.
4. Install the ID chip onto the new board (see [FIGURE 2-7](#)).

- a. Position the notched side of the ID chip to the left.
- b. Place the ID chip directly over the connector.
- c. Press down easily to seat the ID chip to the connector.

FIGURE 2-7 Installing the ID Chip

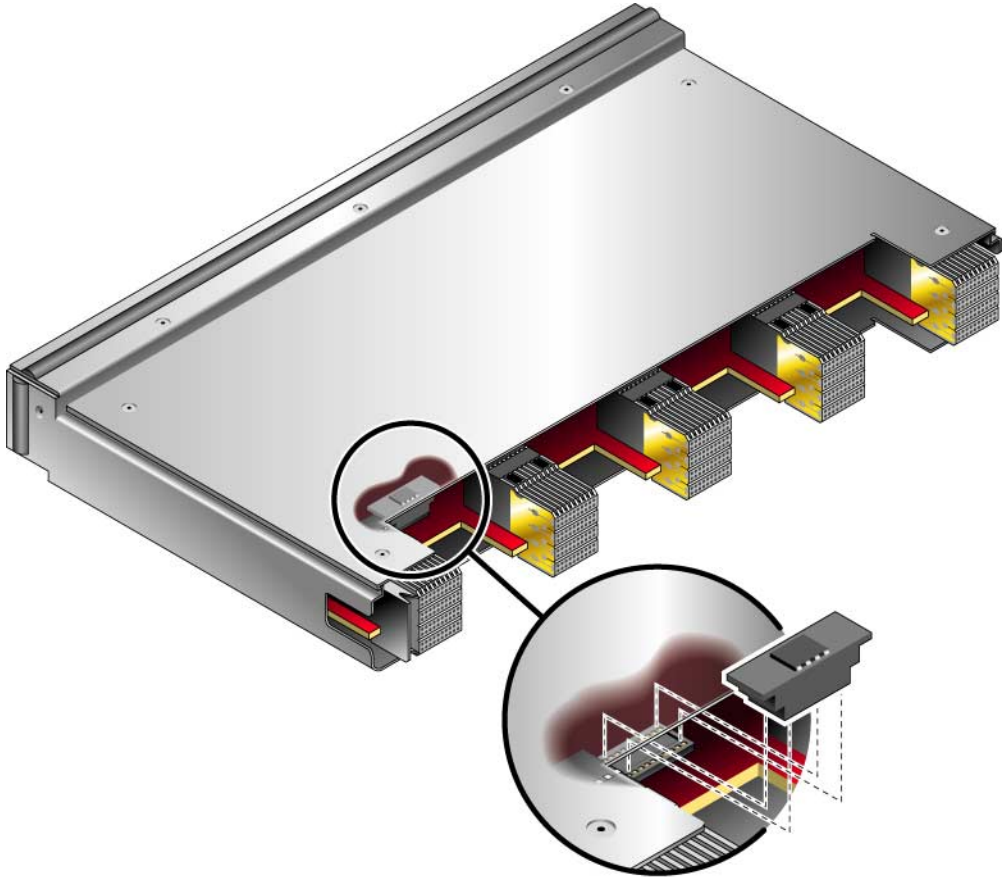

5. Install the replacement NEM into the chassis and reconnect the cables.

HBA Software Installation

After you have completed the hardware installation, follow the instructions listed in this chapter for your operating system to install the HBA driver and any other utilities required for your installation.

This chapter contains the following topics:

- “Driver Software for the Solaris OS” on page 23
- “Driver Software for Linux OSs” on page 24
- “Driver Software for Windows 2003 OS” on page 26
- “Configuration and Diagnostic Utilities” on page 26

Driver Software for the Solaris OS

The latest HBA driver for the Solaris OS is included with Solaris 10 patch 120223-22. See “Operating System Requirements” on page 4 for more information.

Solaris Diagnostic Support

Diagnostic support for the HBA is included in the SunVTS™ software beginning with version 6.3. The SunVTS software is included with Solaris 10 11/06. It is also available for download at:

<http://www.sun.com/oem/products/vts>

The `emlxtest` utility supports the following functions:

- Connectivity verification
- Firmware version and checksum test

- Self-test
 - Loopback tests
 - External
 - Internal, single-bit
 - Internal, 10-bit
 - Mailbox
-

Driver Software for Linux OSs

The Sun StorageTek 4 Gb FC NEM 20-Port HBA is supported by Red Hat Enterprise Linux (RHEL) 4 U3 and U4 and Novell SUSE Linux Enterprise Server 9 Service Pack 3 (SLES9-SP3).

Red Hat Enterprise Linux

The HBA driver distributed with Red Hat Enterprise Linux (RHEL) 4 U3 and U4 supports the NEM. No additional driver updates are required.

Novell SUSE Linux Enterprise Server

The HBA driver distributed with SUSE Linux Enterprise Server 9 Service Pack 3 (SLES9-SP3) has the following known problems:

- The HBA driver does not recognize the NEM device and will prevent it from loading.
- A system panic occurs when the HBA driver is unloaded.

To resolve these problems, update to the Emulex driver version 8.0.16.27 as described in the next section.

▼ To Update the Driver

1. **Run** `/sbin/update-pciids`.

This command uploads the latest database which contains all supported PCI devices by Linux, including the NEM.

2. Run YaST online.

You will be notified that the 8.0.16.27 is being installed.

Note – If you are running on a 2.6.5-7.244 kernel, you must install the Emulex 8.0.16.27 driver manually instead of updating using YaST. The driver RPM is contained on the resource CD.

▼ To Install SLES9-SP3 to FC Disk

Before starting this procedure, you will need to create a driver update disk using the ISO image for driver version 8.0.16.27 provided on the Sun Blade 8000 Series Modular Systems resource CD. You can also download the Emulex driver update disk from the Emulex or Novell support web site.

Emulex web site:

<http://www.emulex.com/sun/support/nem-e11000.jsp>

Novell web site:

<http://forgeftp.novell.com/driver-process/pub/update/SUN/sle9/DUD/emulex8.0.16.27/>

To update the driver to version 8.0.16.27:

1. **Install SLES9-SP3 using the normal install process.**
2. **When prompted for the update disk, load the driver update CD.**
3. **Continue the installation until all files are installed and the system reboots.**
4. **After the system reboots, follow the steps described in “To Update the Driver” on page 24.**

▼ To Build the Linux 2.6 Driver

You can build your own HBA driver by downloading the archived sources from the Emulex support site.

1. **To download the archived sources, go to:**

<http://www.emulex.com/sun/support/nem-e11000.jsp>

2. **Click the Linux 2.6 Kernel link.**

3. Follow the instructions in the README file to build and install the 8.0.16.27 driver.

Driver Software for Windows 2003 OS

The HBA driver for Windows 2003 OS is available for download at the Emulex support site for Sun Microsystems.

<http://www.emulex.com/sun/support/nem-e11000.jsp>

▼ To Install Windows OS Driver and Application Kits

Follow these steps to download the driver and AutoPilot installer:

1. Go to the Emulex support site for Sun Microsystems at:

<http://www.emulex.com/sun/support/nem-e11000.jsp>

2. Locate the driver section for Windows.
3. Download the Driver Kit by clicking the Download icon.
4. Click the PDF Manual icon to download installation, configuration, and troubleshooting information for the Windows OS.
5. Install the driver and management utilities for the Windows OS as described in the Emulex installation guide you downloaded in the previous step.

Configuration and Diagnostic Utilities

Use the HBA anywhere Remote Management Utility or the `lputil` command-line interface (CLI) utility to configure the HBA. These utilities are available for Linux and the Windows OS and provide support for the following functions:

- Discover local and remote hosts, HBAs, targets, and LUNs
- Reset HBAs
- Set HBA driver parameters
- Update firmware

- Enable or disable the system BIOS
- Run diagnostic tests on HBAs
- Manage out-of-band HBAs
- Manage local and in-band remote HBAs

See the Linux or Windows OS Emulex user manual for more information about using the HBA`Anywhere` and `lputil` utilities.

Release Notes

This chapter contains the latest supplementary information for the preceding chapters in this guide. It contains the following topics:

- [Using the NEM With Sun StorEdge 3510 and 3511 Arrays](#)
- [Solaris OS-Specific Issues](#)
- [SUSE Linux Enterprise-Specific Issues](#)
- [Windows Server 2003 OS-Specific Issues](#)

For additional information related to the Sun StorageTek 4 Gb FC NEM 20-Port HBA, see the Sun Blade 8000 Module System documentation set.

Using the NEM With Sun StorEdge 3510 and 3511 Arrays

You cannot connect the Sun StorEdge 3510 RAID array or Sun StorEdge 3511 FC with SATA RAID array to the NEM on the same channel that use different speeds (1 Gb and 2 Gb). You can, however, mix 1-Gb and 2-Gb FC HBAs on different controller channels. This limitation is due to the design of the Sun StorEdge 3510 RAID array's port bypass circuitry and the inability of FC to support auto-negotiation in a multi-drop loop configuration.

Host connectors channels 4 and 5 of the 3511 FC cannot auto-negotiate to 1 Gbit which limits the number of hosts that can be direct-attached using 1 Gbit HBAs. Channels 0 and 1 are able to auto-negotiate to 1 Gbit and allow up to four connections in a dual-controller configuration or two connectors each in a single-controller configuration.

Solaris OS-Specific Issues

The following known issues are related to installing, configuring, or operating the NEM with the Solaris 10 OS.

Out of Option ROM Memory Error in System BIOS

Problem: A fully populated Sun Blade 8000 chassis with at least one NEM installed, could cause the Out of Option ROM Memory Space error to occur during BIOS POST.

Workaround: Disable some of the slots in the Basic Input/Output System (BIOS) using the BIOS Setup utility. For information about disabling Option ROM, see BIOS Option ROMs in the *Sun Blade 8000 Series Online Information System*.

For information about how to boot from a FC storage device connected to the NEM, see Appendix A in the *Sun Blade 8000 Series Installation Guide*.

SUSE Linux Enterprise-Specific Issues

Problem: The HBA driver distributed with SUSE Linux Enterprise Server 9 Service Pack 3 (SLES9-SP3) has the following known problems:

- The HBA driver does not recognize the NEM device and will prevent it from loading.
- A system panic occurs when the HBA driver is unloaded.

Workaround: To resolve these problems, update to the Emulex driver version 8.0.16.27 as described in [“To Update the Driver”](#) on page 24.

Windows Server 2003 OS-Specific Issues

See the Emulex driver manuals for any known issues with the Windows OS drivers.

Declaration of Conformity, Regulatory Compliance, and Safety Statements

This appendix contains the following information that applies to the Sun StorageTek 4 Gb FC NEM 20-Port HBA:

- [“Declaration of Conformity” on page 33](#)
- [“Safety Agency Compliance Statement” on page 35](#)
- [“Regulatory Compliance Statements” on page 47](#)

Declaration of Conformity

Compliance Model Number: 375-3385-XX
Product Family Name: Sun StorageTek 4 Gb FC NEM HBA

EMC

USA - FCC Class A

This equipment complies with Part 15 of the FCC Rules. Operation is subject to the following two conditions:

- 1) This equipment may not cause harmful interference.
- 2) This equipment must accept any interference that may cause undesired operation.

Manufactured by Emulex Corporation

European Union

This equipment complies with the following requirements of the EMC Directive 89/336/EEC:

As Information Technology Equipment (ITE) Class A per (as applicable):

EN 55022:1994 +A1:1995 +A2:1997 Class A

EN 61000-3-2:2000 +A2:2005 Pass

EN 61000-3-3:1995 +A1:2001 Pass

EN 55024:1998 +A1: 2001 +A2:2003 Required Limits:

IEC 61000-4-2	4 kV (Direct), 8 kV (Air)
IEC 61000-4-3	3 V/m
IEC 61000-4-4	1 kV AC Power Lines, 0.5 kV Signal and DC Power Lines
IEC 61000-4-5	1 kV AC Line-Line and Outdoor Signal Lines, 2 kV AC Line-Gnd, 0.5 kV DC Power Lines
IEC 61000-4-6	3 V
IEC 61000-4-8	1 A/m
IEC 61000-4-11	Pass

Safety

This equipment complies with the following requirements of Low Voltage Directive 73/23/EEC:

EC Type Examination Certificates:

EN 60950-1:2001, 1st Edition

IEC 60950-1:2001, 1st Edition CB Scheme Certificate No. US-TUVR-3269

Evaluated to all CB Countries

UL and cUL/CSA 60950-1:2001, CSA C22.2 No. 60950-00 File: E157779 vol. x3

FDA DHHS Accession Number (Monitor Only)

Supplementary Information: This equipment was tested and complies with all the requirements for the CE Mark.

This equipment complies with the Restriction of Hazardous Substances (RoHS) directive 2002/95/EC.

_____/S/_____ Dennis P. Symanski	DATE	_____/S/_____ Donald Cameron	DATE
Worldwide Compliance Office Sun Microsystems, Inc. 4150 Network Circle, MPK15-102 Santa Clara, CA 95054, USA Tel: 650-786-3255 Fax: 650-786-3723		Program Manager/Quality Systems Sun Microsystems Scotland, Limited Blackness Road, Phase I, Main Bldg Springfield, EH49 7LR Scotland, United Kingdom Tel: +44 1 506 672 539 Fax: +44 1 506 670 011	

Safety Agency Compliance Statement

Read this section before beginning any procedure. The following text provides safety precautions to follow when installing a Sun Microsystems product.

Safety Precautions

For your protection, observe the following safety precautions when setting up your equipment:

- Follow all cautions and instructions marked on the equipment.
- Ensure that the voltage and frequency of your power source match the voltage and frequency inscribed on the equipment's electrical rating label.
- Never push objects of any kind through openings in the equipment. Dangerous voltages may be present. Conductive foreign objects could produce a short circuit that could cause fire, electric shock, or damage to your equipment.

Symbols

The following symbols may appear in this book:



Caution – There is a risk of personal injury and equipment damage. Follow the instructions.



Caution – Hot surface. Avoid contact. Surfaces are hot and may cause personal injury if touched.



Caution – Hazardous voltages are present. To reduce the risk of electric shock and danger to personal health, follow the instructions.

Depending on the type of power switch your device has, one of the following symbols may be used:



On – Applies AC power to the system.



Off – Removes AC power from the system.



Standby – The On/Standby switch is in the standby position.

Modifications to Equipment

Do not make mechanical or electrical modifications to the equipment. Sun Microsystems is not responsible for regulatory compliance of a modified Sun product.

Placement of a Sun Product



Caution – Do not block or cover the openings of your Sun product. Never place a Sun product near a radiator or heat register. Failure to follow these guidelines can cause overheating and affect the reliability of your Sun product.

Noise Level

Declared noise emissions in accordance with ISO 9296, A-weighted, operating and idling:

Measure and Environment

L_{wAd} (1B = 10 dB)

at or below 25°C	8.0 B
at max ambient	8.4 B

L_{pAm} bystander

at or below 25°C	66 dB
at max ambient	69 dB

SELV Compliance

Safety status of I/O connections comply to SELV requirements.

Power Cord Connection



Caution – Sun products are designed to work with power systems having a grounded neutral (grounded return for DC-powered products). To reduce the risk of electric shock, do not plug Sun products into any other type of power system. Contact your facilities manager or a qualified electrician if you are not sure what type of power is supplied to your building.



Caution – Not all power cords have the same current ratings. Do not use the power cord provided with your equipment for any other products or use. Household extension cords do not have overload protection and are not meant for use with computer systems. Do not use household extension cords with your Sun product.



注意 – 添付の電源コードを他の装置や用途に使用しない
添付の電源コードは本装置に接続し、使用することを目的として設計され、その安全性が確認されているものです。決して他の装置や用途に使用しないでください。火災や感電の原因となる恐れがあります。

The following caution applies only to devices with a Standby power switch:



Caution – The power switch of this product functions as a standby type device only. The power cord serves as the primary disconnect device for the system. Be sure to plug the power cord into a grounded power outlet that is nearby the system and is readily accessible. Do not connect the power cord when the power supply has been removed from the system chassis.

The following caution applies only to devices with multiple power cords:



Caution – For products with multiple power cords, all power cords must be disconnected to completely remove power from the system.

Battery Warning



Caution – There is danger of explosion if batteries are mishandled or incorrectly replaced. On systems with replaceable batteries, replace only with the same manufacturer and type or equivalent type recommended by the manufacturer per the instructions provided in the product service manual. Do not disassemble batteries or attempt to recharge them outside the system. Do not dispose of batteries in fire. Dispose of batteries properly in accordance with the manufacturer's instructions and local regulations. Note that on Sun CPU boards, there is a lithium battery molded into the real-time clock. These batteries are not customer replaceable parts.

System Unit Cover

You must remove the cover of your Sun computer system unit to add cards, memory, or internal storage devices. Be sure to replace the cover before powering on your computer system.



Caution – Do not operate Sun products without the cover in place. Failure to take this precaution may result in personal injury and system damage.

Rack System Warning

The following warnings apply to Racks and Rack Mounted systems.



Caution – For safety, equipment should always be loaded from the bottom up. That is, install the equipment that will be mounted in the lowest part of the rack first, then the next higher systems, etc.



Caution – To prevent the rack from tipping during equipment installation, the anti-tilt bar on the rack must be deployed.



Caution – To prevent extreme operating temperature within the rack insure that the maximum temperature does not exceed the product's ambient rated temperatures.



Caution – To prevent extreme operating temperatures due to reduced airflow consideration should be made to the amount of air flow that is required for a safe operation of the equipment.

Laser Compliance Notice

Sun products that use laser technology comply with Class 1 laser requirements.

Class 1 Laser Product
Luokan 1 Laserlaitte
Klasse 1 Laser Apparat
Laser Klasse 1

CD and DVD Devices

The following caution applies to CD, DVD, and other optical devices.



Caution – Use of controls, adjustments, or the performance of procedures other than those specified herein may result in hazardous radiation exposure.

Conformité aux normes de sécurité

Veillez lire attentivement cette section avant de commencer. Ce texte traite des mesures de sécurité qu'il convient de prendre pour l'installation d'un produit Sun Microsystems.

Mesures de sécurité

Pour votre sécurité, nous vous recommandons de suivre scrupuleusement les mesures de sécurité ci-dessous lorsque vous installez votre matériel:

- Suivez tous les avertissements et toutes les instructions inscrites sur le matériel.
- Assurez-vous que la tension et la fréquence de votre source d'alimentation correspondent à la tension et à la fréquence indiquées sur l'étiquette de la tension électrique nominale du matériel
- N'introduisez jamais d'objets quels qu'ils soient dans les ouvertures de l'équipement. Vous pourriez vous trouver en présence de hautes tensions dangereuses. Tout objet étranger conducteur risque de produire un court-circuit pouvant présenter un risque d'incendie ou de décharge électrique, ou susceptible d'endommager le matériel.

Symboles

Vous trouverez ci-dessous la signification des différents symboles utilisés:



Attention – Vous risquez d'endommager le matériel ou de vous blesser. Veuillez suivre les instructions.



Attention – Surfaces brûlantes. Evitez tout contact. Les surfaces sont brûlantes. Vous risquez de vous blesser si vous les touchez.



Attention – Tensions dangereuses. Pour réduire les risques de décharge électrique et de danger physique, observez les consignes indiquées.

Selon le type d'interrupteur marche/arrêt dont votre appareil est équipé, l'un des symboles suivants sera utilisé:



Marche – Met le système sous tension alternative.



Arrêt – Met le système hors tension alternative.



Veilleuse – L'interrupteur Marche/Veille est sur la position de veille.

Modification du matériel

N'apportez aucune modification mécanique ou électrique au matériel. Sun Microsystems décline toute responsabilité quant à la non-conformité éventuelle d'un produit Sun modifié.

Positionnement d'un produit Sun



Attention – Evitez d'obstruer ou de recouvrir les orifices de votre produit Sun. N'installez jamais un produit Sun près d'un radiateur ou d'une source de chaleur. Si vous ne respectez pas ces consignes, votre produit Sun risque de surchauffer et son fonctionnement en sera altéré.

Niveau de pression acoustique

Valeurs déclarées d'émission acoustique en conformité avec la norme ISO 9296, Pondéré A, en fonctionnement et inactif:

Mesure et environnement

L_{wAd} (1B = 10 dB)

à ou en dessous de 25°C 8.0 B

à temp. ambiante maxi. 8.4 B

L_{pAm} assistant

à ou en dessous de 25°C 66 dB

à temp. ambiante maxi. 69 dB

Conformité SELV

Le niveau de sécurité des connexions E/S est conforme aux normes SELV.

Connexion du cordon d'alimentation



Attention – Les produits Sun sont conçus pour fonctionner avec des systèmes d'alimentation équipés d'un conducteur neutre relié à la terre (conducteur neutre pour produits alimentés en CC). Pour réduire les risques de décharge électrique, ne branchez jamais les produits Sun sur une source d'alimentation d'un autre type. Contactez le gérant de votre bâtiment ou un électricien agréé si vous avez le moindre doute quant au type d'alimentation fourni dans votre bâtiment.



Attention – Tous les cordons d'alimentation ne présentent pas les mêmes caractéristiques électriques. Les cordons d'alimentation à usage domestique ne sont pas protégés contre les surtensions et ne sont pas conçus pour être utilisés avec des ordinateurs. N'utilisez jamais de cordon d'alimentation à usage domestique avec les produits Sun.

L'avertissement suivant s'applique uniquement aux systèmes équipés d'un interrupteur Veille:



Attention – L'interrupteur d'alimentation de ce produit fonctionne uniquement comme un dispositif de mise en veille. Le cordon d'alimentation constitue le moyen principal de déconnexion de l'alimentation pour le système. Assurez-vous de le brancher dans une prise d'alimentation mise à la terre près du système et facile d'accès. Ne le branchez pas lorsque l'alimentation électrique ne se trouve pas dans le châssis du système.

L'avertissement suivant s'applique uniquement aux systèmes équipés de plusieurs cordons d'alimentation:



Attention – Pour mettre un système équipé de plusieurs cordons d'alimentation hors tension, il est nécessaire de débrancher tous les cordons d'alimentation.

Mise en garde relative aux batteries



Attention – Les batteries risquent d'exploser en cas de manipulation maladroite ou de remplacement incorrect. Pour les systèmes dont les batteries sont remplaçables, effectuez les remplacements uniquement selon le modèle du fabricant ou un modèle équivalent recommandé par le fabricant, conformément aux instructions fournies dans le manuel de service du système. N'essayez en aucun cas de démonter les batteries, ni de les recharger hors du système. Ne les jetez pas au feu. Mettez-les au rebut selon les instructions du fabricant et conformément à la législation locale en vigueur. Notez que sur les cartes processeur de Sun, une batterie au lithium a été moulée dans l'horloge temps réel. Les batteries ne sont pas des pièces remplaçables par le client.

Couvercle de l'unité

Pour ajouter des cartes, de la mémoire ou des périphériques de stockage internes, vous devez retirer le couvercle de votre système Sun. Remettez le couvercle supérieur en place avant de mettre votre système sous tension.



Attention – Ne mettez jamais des produits Sun sous tension si leur couvercle supérieur n'est pas mis en place. Si vous ne prenez pas ces précautions, vous risquez de vous blesser ou d'endommager le système.

Mise en garde relative au système en rack

La mise en garde suivante s'applique aux racks et aux systèmes montés en rack.



Attention – Pour des raisons de sécurité, le matériel doit toujours être chargé du bas vers le haut. En d'autres termes, vous devez installer, en premier, le matériel qui doit se trouver dans la partie la plus inférieure du rack, puis installer le matériel sur le niveau suivant, etc.



Attention – Afin d'éviter que le rack ne penche pendant l'installation du matériel, tirez la barre anti-basculement du rack.



Attention – Pour éviter des températures de fonctionnement extrêmes dans le rack, assurez-vous que la température maximale ne dépasse pas la fourchette de températures ambiantes du produit déterminée par le fabricant.



Attention – Afin d'empêcher des températures de fonctionnement extrêmes provoquées par une aération insuffisante, assurez-vous de fournir une aération appropriée pour un fonctionnement du matériel en toute sécurité

Avis de conformité des appareils laser

Les produits Sun qui font appel aux technologies lasers sont conformes aux normes de la classe 1 en la matière.

Class 1 Laser Product
Luokan 1 Laserlaite
Klasse 1 Laser Apparat
Laser Klasse 1

Périphériques CD et DVD

L'avertissement suivant s'applique aux périphériques CD, DVD et autres périphériques optiques:



Attention – L'utilisation de contrôles et de réglages ou l'application de procédures autres que ceux spécifiés dans le présent document peuvent entraîner une exposition à des radiations dangereuses.

Einhaltung sicherheitsbehördlicher Vorschriften

Lesen Sie vor dem Ausführen von Arbeiten diesen Abschnitt. Im folgenden Text werden Sicherheitsvorkehrungen beschrieben, die Sie bei der Installation eines Sun Microsystems-Produkts beachten müssen.

Sicherheitsvorkehrungen

Treffen Sie zu Ihrem eigenen Schutz bei der Installation des Geräts die folgenden Sicherheitsvorkehrungen:

- Beachten Sie alle auf den Geräten angebrachten Warnhinweise und Anweisungen.
- Stellen Sie sicher, dass Spannung und Frequenz der Stromversorgung den Nennleistungen auf dem am Gerät angebrachten Etikett entsprechen.
- Führen Sie niemals Fremdobjekte in die Öffnungen am Gerät ein. Es können gefährliche Spannungen anliegen. Leitfähige Fremdobjekte können einen Kurzschluss verursachen, der einen Brand, Stromschlag oder Geräteschaden herbeiführen kann.

Symbole

Die Symbole in diesem Handbuch haben folgende Bedeutung:



Achtung – Gefahr von Verletzung und Geräteschaden. Befolgen Sie die Anweisungen.



Achtung – Heiße Oberfläche. Nicht berühren, da Verletzungsgefahr durch heiße Oberfläche besteht.



Achtung – Gefährliche Spannungen. Befolgen Sie die Anweisungen, um Stromschläge und Verletzungen zu vermeiden.

Je nach Netzschaltertyp an Ihrem Gerät kann eines der folgenden Symbole verwendet werden:



Ein – Versorgt das System mit Wechselstrom.



Aus – Unterbricht die Wechselstromzufuhr zum Gerät.



Wartezustand – Der Ein-/Standby-Netzschalter befindet sich in der Standby-Position.

Modifikationen des Geräts

Nehmen Sie keine elektrischen oder mechanischen Gerätemodifikationen vor. Sun Microsystems ist für die Einhaltung der Sicherheitsvorschriften von modifizierten Sun-Produkten nicht haftbar.

Aufstellung von Sun-Geräten



Achtung – Geräteöffnungen Ihres Sun-Produkts dürfen nicht blockiert oder abgedeckt werden. Sun-Geräte sollten niemals in der Nähe von Heizkörpern oder Heißluftklappen aufgestellt werden. Die Nichtbeachtung dieser Richtlinien kann Überhitzung verursachen und die Zuverlässigkeit Ihres Sun-Geräts beeinträchtigen.

Lautstärke

Angegebene Geräuschentwicklung im Einklang mit ISO 9296, A-bewertet, in Betrieb und im Ruhezustand:

Messwert und Umgebung

L_{wAd} (1B = 10 dB)

bei oder unter 25°C 8.0 B

bei max. Umgebung 8.4 B

L_{pAm} Umstehende

bei oder unter 25°C 66 dB

bei max. Umgebung 69 dB

SELV-Konformität

Der Sicherheitsstatus der E/A-Verbindungen entspricht den SELV-Anforderungen.

Anschluss des Netzkabels



Achtung – Sun-Geräte sind für Stromversorgungssysteme mit einem geerdeten neutralen Leiter (geerdeter Rückleiter bei gleichstrombetriebenen Geräten) ausgelegt. Um die Gefahr von Stromschlägen zu vermeiden, schließen Sie das Gerät niemals an andere Stromversorgungssysteme an. Wenden Sie sich an den zuständigen Gebäudeverwalter oder an einen qualifizierten Elektriker, wenn Sie nicht sicher wissen, an welche Art von Stromversorgungssystem Ihr Gebäude angeschlossen ist.



Achtung – Nicht alle Netzkabel verfügen über die gleichen Nennwerte. Herkömmliche, im Haushalt verwendete Verlängerungskabel besitzen keinen Überlastschutz und sind daher für Computersysteme nicht geeignet. Verwenden Sie bei Ihrem Sun-Produkt keine Haushalts-Verlängerungskabel.

Die folgende Warnung gilt nur für Geräte mit Standby-Netzschalter:



Achtung – Beim Netzschalter dieses Geräts handelt es sich nur um einen Ein-/Standby-Schalter. Zum völligen Abtrennen des Systems von der Stromversorgung dient hauptsächlich das Netzkabel. Stellen Sie sicher, dass das Netzkabel an eine frei zugängliche geerdete Steckdose in der Nähe des Systems angeschlossen ist. Schließen Sie das Stromkabel nicht an, wenn die Stromversorgung vom Systemchassis entfernt wurde.

Die folgende Warnung gilt nur für Geräte mit mehreren Netzkabeln:



Achtung – Bei Produkten mit mehreren Netzkabeln müssen alle Netzkabel abgetrennt werden, um das System völlig von der Stromversorgung zu trennen.

Warnung bezüglich Batterien



Achtung – Bei unsachgemäßer Handhabung oder nicht fachgerechtem Austausch der Batterien besteht Explosionsgefahr. Verwenden Sie bei Systemen mit austauschbaren Batterien ausschließlich Ersatzbatterien desselben Typs und Herstellers bzw. einen entsprechenden, vom Hersteller gemäß den Anweisungen im Service-Handbuch des Produkts empfohlenen Batterietyp. Versuchen Sie nicht, die Batterien auszubauen oder außerhalb des Systems wiederaufzuladen. Werfen Sie die Batterien nicht ins Feuer. Entsorgen Sie die Batterien entsprechend den Anweisungen des Herstellers und den vor Ort geltenden Vorschriften. CPU-Karten von Sun verfügen über eine Echtzeituhr mit integrierter Lithiumbatterie. Diese Batterie darf nur von einem qualifizierten Servicetechniker ausgetauscht werden.

Gehäuseabdeckung

Sie müssen die Abdeckung Ihres Sun-Computersystems entfernen, um Karten, Speicher oder interne Speichergeräte hinzuzufügen. Bringen Sie vor dem Einschalten des Systems die Gehäuseabdeckung wieder an.



Achtung – Nehmen Sie Sun-Geräte nicht ohne Abdeckung in Betrieb. Die Nichtbeachtung dieses Warnhinweises kann Verletzungen oder Geräteschaden zur Folge haben.

Warnungen bezüglich in Racks eingebauter Systeme

Die folgenden Warnungen gelten für Racks und in Racks eingebaute Systeme:



Achtung – Aus Sicherheitsgründen sollten sämtliche Geräte von unten nach oben in Racks eingebaut werden. Installieren Sie also zuerst die Geräte, die an der untersten Position im Rack eingebaut werden, gefolgt von den Systemen, die an nächsthöherer Stelle eingebaut werden, usw.



Achtung – Verwenden Sie beim Einbau den Kippschutz am Rack, um ein Umkippen zu vermeiden.



Achtung – Um extreme Betriebstemperaturen im Rack zu vermeiden, stellen Sie sicher, dass die Maximaltemperatur die Nennleistung der Umgebungstemperatur für das Produkt nicht überschreitet



Achtung – Um extreme Betriebstemperaturen durch verringerte Luftzirkulation zu vermeiden, sollte die für den sicheren Betrieb des Geräts erforderliche Luftzirkulation eingesetzt werden.

Hinweis zur Laser-Konformität

Sun-Produkte, die die Laser-Technologie verwenden, entsprechen den Laser-Anforderungen der Klasse 1.

Class 1 Laser Product
Luokan 1 Laserlaite
Klasse 1 Laser Apparat
Laser Klasse 1

CD- und DVD-Geräte

Die folgende Warnung gilt für CD-, DVD- und andere optische Geräte:



Achtung – Die hier nicht aufgeführte Verwendung von Steuerelementen, Anpassungen oder Ausführung von Vorgängen kann eine gefährliche Strahlenbelastung verursachen.

Normativas de seguridad

Lea esta sección antes de realizar cualquier operación. En ella se explican las medidas de seguridad que debe tomar al instalar un producto de Sun Microsystems.

Medidas de seguridad

Para su protección, tome las medidas de seguridad siguientes durante la instalación del equipo:

- Siga todos los avisos e instrucciones indicados en el equipo.
- Asegúrese de que el voltaje y frecuencia de la fuente de alimentación coincidan con el voltaje y frecuencia indicados en la etiqueta de clasificación eléctrica del equipo.
- No introduzca objetos de ningún tipo por las rejillas del equipo, ya que puede quedar expuesto a voltajes peligrosos. Los objetos conductores extraños pueden producir cortocircuitos y, en consecuencia, incendios, descargas eléctricas o daños en el equipo.

Símbolos

En este documento aparecen los siguientes símbolos:



Precaución – Existe el riesgo de que se produzcan lesiones personales y daños en el equipo. Siga las instrucciones.



Precaución – Superficie caliente. Evite todo contacto. Las superficies están calientes y pueden causar lesiones personales si se tocan.



Precaución – Voltaje peligroso. Para reducir el riesgo de descargas eléctricas y lesiones personales, siga las instrucciones.

En función del tipo de interruptor de alimentación del que disponga el dispositivo, se utilizará uno de los símbolos siguientes:



Encendido – Suministra alimentación de CA al sistema.



Apagado – Corta la alimentación de CA del sistema.



Espera – El interruptor de encendido/espera está en la posición de espera.

Modificaciones en el equipo

No realice modificaciones de tipo mecánico ni eléctrico en el equipo. Sun Microsystems no se hace responsable del cumplimiento de normativas en caso de que un producto Sun se haya modificado.

Colocación de un producto Sun



Precaución – No obstruya ni tape las rejillas del producto Sun. Nunca coloque un producto Sun cerca de radiadores ni fuentes de calor. Si no sigue estas indicaciones, el producto Sun podría sobrecalentarse y la fiabilidad de su funcionamiento se vería afectada.

Nivel de ruido

Emissiones acústicas declaradas de acuerdo con la norma ISO 9296 (decibelios A), en funcionamiento y reposo:

Medición y condiciones ambientales

L_{wAd} (1B = 10 dB)

a 25°C o menos:	8.0 B
máxima temp. ambiente:	8.4 B

L_{pAm} (posición de observación)

a 25°C o menos:	66 dB
máxima temp. ambiente:	69 dB

Cumplimiento de la normativa para instalaciones SELV

Las condiciones de seguridad de las conexiones de entrada y salida cumplen los requisitos para instalaciones SELV (del inglés *Safe Extra Low Voltage*, voltaje bajo y seguro).

Conexión del cable de alimentación



Precaución – Los productos Sun se han diseñado para funcionar con sistemas de alimentación que cuenten con un conductor neutro a tierra (con conexión a tierra de regreso para los productos con alimentación de CC). Para reducir el riesgo de descargas eléctricas, no conecte ningún producto Sun a otro tipo de sistema de alimentación. Póngase en contacto con el encargado de las instalaciones de su empresa o con un electricista cualificado en caso de que no esté seguro del tipo de alimentación del que se dispone en el edificio.



Precaución – No todos los cables de alimentación tienen la misma clasificación eléctrica. Los alargadores de uso doméstico no cuentan con protección frente a sobrecargas y no están diseñados para su utilización con sistemas informáticos. No utilice alargadores de uso doméstico con el producto Sun.

La siguiente medida solamente se aplica a aquellos dispositivos que dispongan de un interruptor de alimentación de espera:



Precaución – El interruptor de alimentación de este producto funciona solamente como un dispositivo de espera. El cable de alimentación hace las veces de dispositivo de desconexión principal del sistema. Asegúrese de que conecta el cable de alimentación a una toma de tierra situada cerca del sistema y de fácil acceso. No conecte el cable de alimentación si la unidad de alimentación no se encuentra en el bastidor del sistema.

La siguiente medida solamente se aplica a aquellos dispositivos que dispongan de varios cables de alimentación:



Precaución – En los productos que cuentan con varios cables de alimentación, debe desconectar todos los cables de alimentación para cortar por completo la alimentación eléctrica del sistema.

Advertencia sobre las baterías



Precaución – Si las baterías no se manipulan o reemplazan correctamente, se corre el riesgo de que estallen. En los sistemas que cuentan con baterías reemplazables, reemplácelas sólo con baterías del mismo fabricante y el mismo tipo, o un tipo equivalente recomendado por el fabricante, de acuerdo con las instrucciones descritas en el manual de servicio del producto. No desmonte las baterías ni intente recargarlas fuera del sistema. No intente deshacerse de las baterías echándolas al fuego. Deshágase de las baterías correctamente de acuerdo con las instrucciones del fabricante y las normas locales. Tenga en cuenta que en las placas CPU de Sun, hay una batería de litio incorporada en el reloj en tiempo real. Los usuarios no deben reemplazar este tipo de baterías.

Cubierta de la unidad del sistema

Debe extraer la cubierta de la unidad del sistema informático Sun para instalar tarjetas, memoria o dispositivos de almacenamiento internos. Vuelva a colocar la cubierta antes de encender el sistema informático.



Precaución – No ponga en funcionamiento los productos Sun que no tengan colocada la cubierta. De lo contrario, puede sufrir lesiones personales y ocasionar daños en el sistema.

Advertencia sobre el sistema en bastidor

Las advertencias siguientes se aplican a los sistemas montados en bastidor y a los propios bastidores.



Precaución – Por seguridad, siempre deben montarse los equipos de abajo arriba. A saber, primero debe instalarse el equipo que se situará en el bastidor inferior; a continuación, el que se situará en el siguiente nivel, etc.



Precaución – Para evitar que el bastidor se vuelque durante la instalación del equipo, debe extenderse la barra antivolcado del bastidor.



Precaución – Para evitar que se alcance una temperatura de funcionamiento extrema en el bastidor, asegúrese de que la temperatura máxima no sea superior a la temperatura ambiente establecida como adecuada para el producto.



Precaución – Para evitar que se alcance una temperatura de funcionamiento extrema debido a una circulación de aire reducida, debe considerarse la magnitud de la circulación de aire requerida para que el equipo funcione de forma segura.

Aviso de cumplimiento de la normativa para la utilización de láser

Los productos Sun que utilizan tecnología láser cumplen los requisitos establecidos para los productos láser de clase 1.

Class 1 Laser Product
Luokan 1 Laserlaite
Klasse 1 Laser Apparat
Laser Klasse 1

Dispositivos de CD y DVD

La siguiente medida se aplica a los dispositivos de CD y DVD, así como a otros dispositivos ópticos:



Precaución – La utilización de controles, ajustes o procedimientos distintos a los aquí especificados puede dar lugar a niveles de radiación peligrosos.

Nordic Lithium Battery Cautions

Norge



Advarsel – Litiumbatteri — Eksplosjonsfare. Ved utskifting benyttes kun batteri som anbefalt av apparatfabrikanten. Brukt batteri returneres apparatleverandøren.

Sverige



Varning – Explosionsfara vid felaktigt batteribyte. Använd samma batterityp eller en ekvivalent typ som rekommenderas av apparattillverkaren. Kassera använt batteri enligt fabrikantens instruktion.

Danmark



Advarsel! – Litiumbatteri — Eksplosionsfare ved fejlagtig håndtering. Udskiftning må kun ske med batteri af samme fabrikat og type. Levér det brugte batteri tilbage til leverandøren.

Suomi



Varoitus – Paristo voi räjähtää, jos se on virheellisesti asennettu. Vaihda paristo ainoastaan laitevalmistajan suosittelemaan tyyppiin. Hävitä käytetty paristo valmistajan ohjeiden mukaisesti.

Regulatory Compliance Statements

Your Sun product is marked to indicate its compliance class:

- Federal Communications Commission (FCC) — USA
- Industry Canada Equipment Standard for Digital Equipment (ICES-003) — Canada
- Bureau of Standards Metrology and Inspection (BSMI) — Taiwan

Please read the appropriate section that corresponds to the marking on your Sun product before attempting to install the product.

FCC Class A Notice

This device complies with Part 15 of the FCC Rules. Operation is subject to the following two conditions:

1. This device may not cause harmful interference.
2. This device must accept any interference received, including interference that may cause undesired operation.

Note: This equipment has been tested and found to comply with the limits for a Class A digital device, pursuant to Part 15 of the FCC Rules. These limits are designed to provide reasonable protection against harmful interference when the equipment is operated in a commercial environment. This equipment generates, uses, and can radiate radio frequency energy, and if it is not installed and used in accordance with the instruction manual, it may cause harmful interference to radio communications. Operation of this equipment in a residential area is likely to cause harmful interference, in which case the user will be required to correct the interference at his own expense.

Modifications: Any modifications made to this device that are not approved by Sun Microsystems, Inc. may void the authority granted to the user by the FCC to operate this equipment.

ICES-003 Class A Notice - Avis NMB-003, Classe A

This Class A digital apparatus complies with Canadian ICES-003.

Cet appareil numérique de la classe A est conforme à la norme NMB-003 du Canada.

VCCI 基準について

クラス A VCCI 基準について

クラス A VCCI の表示があるワークステーションおよびオプション製品は、クラス A 情報技術装置です。これらの製品には、下記の項目が該当します。

この装置は、情報処理装置等電波障害自主規制協議会 (VCCI) の基準に基づくクラス A 情報技術装置です。この装置を家庭環境で使用すると電波妨害を引き起こすことがあります。この場合には使用者が適切な対策を講ずるよう要求されることがあります。

クラス B VCCI 基準について

クラス B VCCI の表示  があるワークステーションおよびオプション製品は、クラス B 情報技術装置です。これらの製品には、下記の項目が該当します。

この装置は、情報処理装置等電波障害自主規制協議会 (VCCI) の基準に基づくクラス B 情報技術装置です。この装置は、家庭環境で使用することを目的としていますが、この装置がラジオやテレビジョン受信機に近接して使用されると、受信障害を引き起こすことがあります。取扱説明書に従って正しい取り扱いをしてください。

BSMI Class A Notice

The following statement is applicable to products shipped to Taiwan and marked as Class A on the product compliance label.

警告使用者：

這是甲類的資訊產品，在居住的環境中使用時，可能會造成射頻干擾，在這種情況下，使用者會被要求採取某些適當的對策。



CCC Class A Notice

The following statement is applicable to products shipped to China and marked with "Class A" on the product's compliance label.

以下声明适用于运往中国且其认证标志上注有 "Class A" 字样的产品。

声明

此为A级产品，在生活环境中，该产品可能会造成无线电干扰。
在这种情况下，可能需要用户对其干扰采取切实可行的措施。



Korean MIC Class A Statement

사용자 안내문 (A급 기기)

본 기기는 업무용으로 전자파적합등록을 받은 기기이오니, 만약 잘못 구입하셨을 때에는 구입한 곳에서 비업무용으로 교환하시기 바랍니다.

CLASS A EQUIPMENT

Please note that this equipment has been approved for business purposes with regards to electromagnetic interference. If purchased in error for use in a residential area, you may wish to exchange the equipment where you purchased it.

Index

A

Attention button, 17, 18

B

BIOS POST, 30

C

cable length, maximum, 2

channel LEDs, 13

chassis monitoring module (CMM)

firmware, 5

using ILOM, 14

compliance statements

regulatory, 47

safety agency, 35

connecting links to blades status

status

NEM LED, 18

connectors

external FC, 2

NEM port, 9

D

Declaration of Conformity, 33

diagnostics, 26

E

electrostatic discharge (ESD) handling

precautions, 8

ESD wrist strap, 8

F

FC switches, 6

Fibre Channel topology, 2

firmware

CMM, 5

service processor, 5

update, 26

H

HBA drivers

known issues, 30

HBAnywhere Remote Management Utility, 26

hot-plug operation

configuring, 14

verifying, 16

I

ID Chip

feature, 3

patch, 19

replace, 20

ILOM

command-line interface (CLI), 15

web interface, 14

in-band remote HBAs, 27

L

LEDs

NEM, 18

port, 13

lights-out management (ILOM) interface, 14

link rate, 13

links connected to blades status, 18

Linux

driver, known issues, 30

supported versions, 4

Locator LED and button, 18

LUNs, discover, 26

M

memory, 2

N

NEM

activating, 17

configuring for hot-plug, 14

installing, 9

interface, 2

LED status, 18

part number, 2

restrictions, 29

status, verifying, 17

NEM port numbering, 11

O

operating systems

supported, 5

operating systems, supported versions, 4

optical cable specifications, 11

Out of Option ROM Memory Space error, 30

out-of-band HBAs, 27

P

patches

required Solaris, 4

PCI transfer rate, 2

port LEDs, 13

port numbering, 11

POST failure, 13

power-on self tests

BIOS, 30

NEM, 12

R

ready to remove status, 18

regulatory compliance statements, 47

Restriction of Hazardous Substances (RoHS)

directive, 33

S

safety precautions, 35

service attention required status, 18

service processor (SP) firmware, 5

SFP fiber-optic transceivers, 2

Small Form-Factor Pluggable (SFP), 2

Solaris OS

known issues, 30

patches, 4

supported versions, 4

standby status, 18

status

NEM LED, 18

port LED definitions, 13

storage systems, 5

Sun Blade 8000 Modular Systems, 5

Sun StorEdge 3510/3511 RAID arrays, 29

sunsolve.sun.com, 19

switches, supported, 6

system BIOS

enable and disable, 27

system panic, 30

W

Windows 2003 OS

driver, 26

supported versions, 4