

**DS 1051 A004-3 1.0/5.0 and DS 1051 A004-3 1.4/6.6**

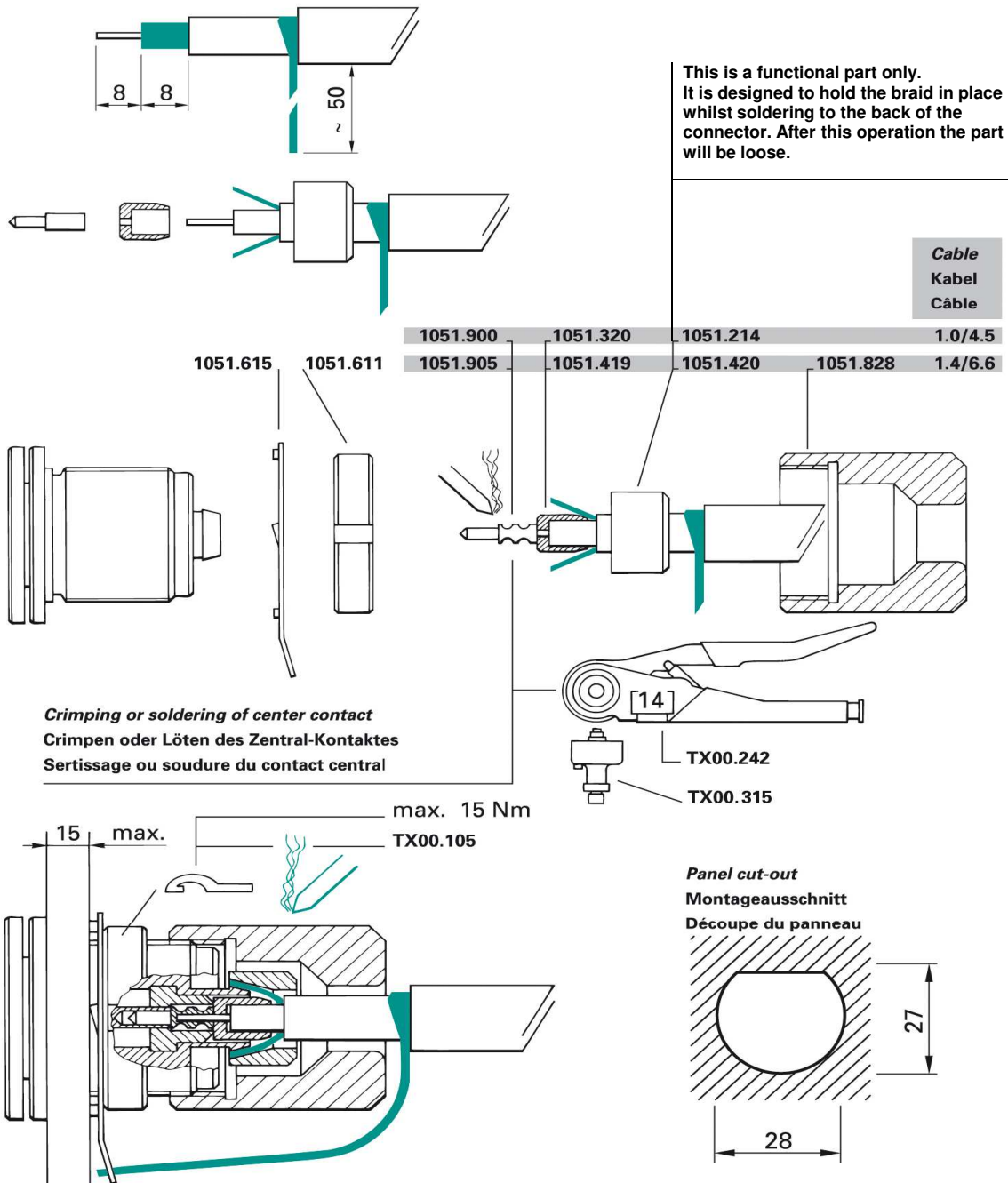

All dimension shown are in millimeters and are for reference only

© Fischer Connectors SA / All rights reserved  
 This document is the property of Fischer Connectors SA.  
 All communications to third parties or the reproduction in any form, even partial, are prohibited without our written consent.

### DB 1051 A004-3 1.0/5.0 and DB 1051 A004-3 1.4/6.6

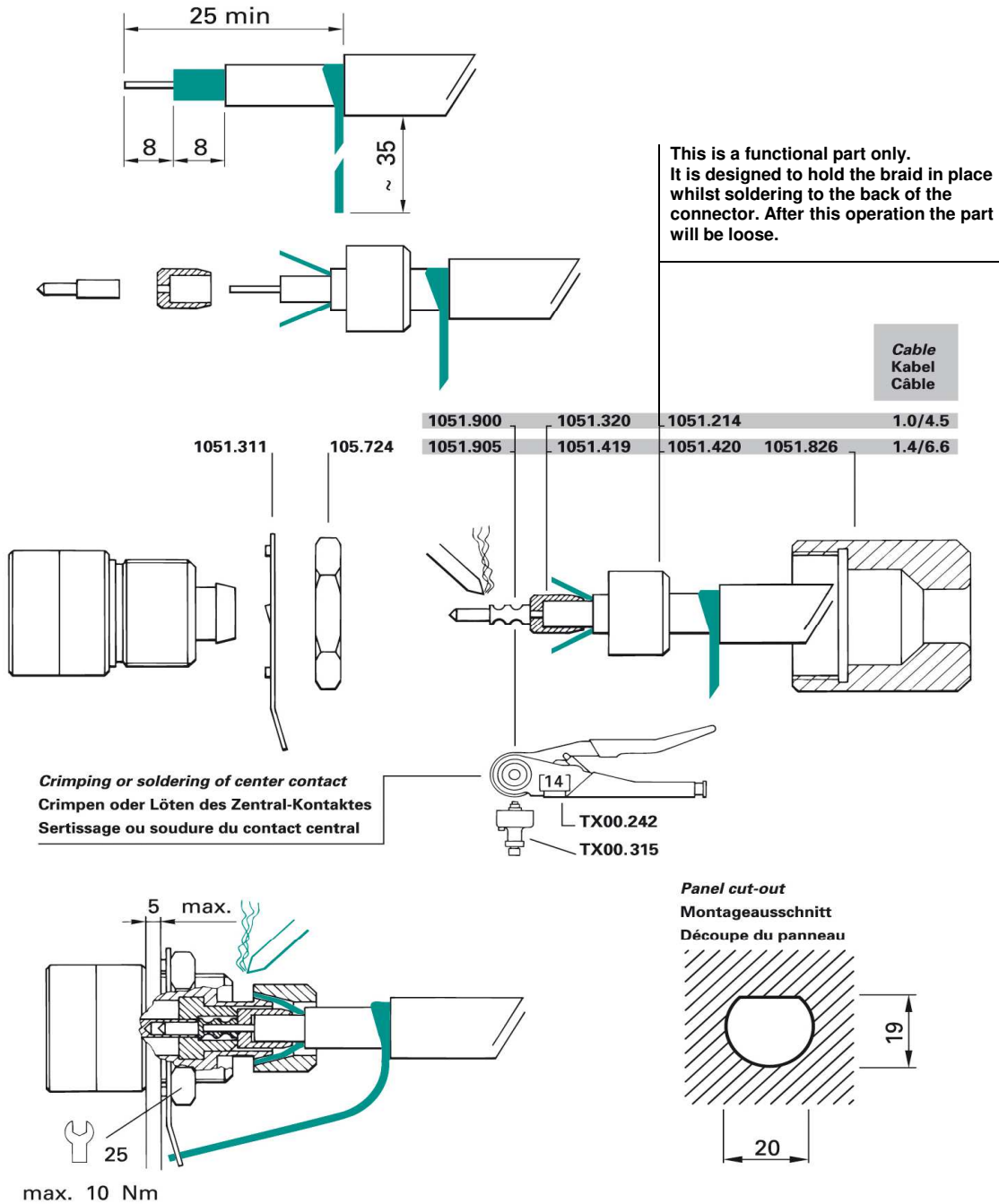

All dimension shown are in millimeters and are for reference only

### DSR and DKE 1051 A004-3

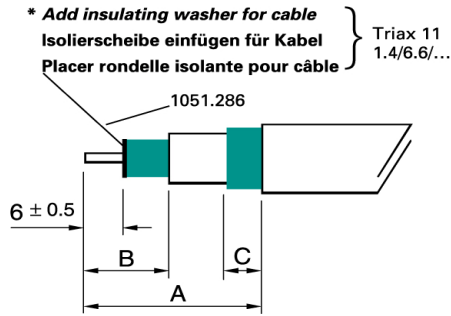

REF.	A	B	C
DSR + DKE 1051 A004-3 1.0/4.5	25	14	7
DSR + DKE 1051 A004-3 1.4/4.5	27	12	7
DSR + DKE 1051 A004-3 1.4/6.6	27	13	5

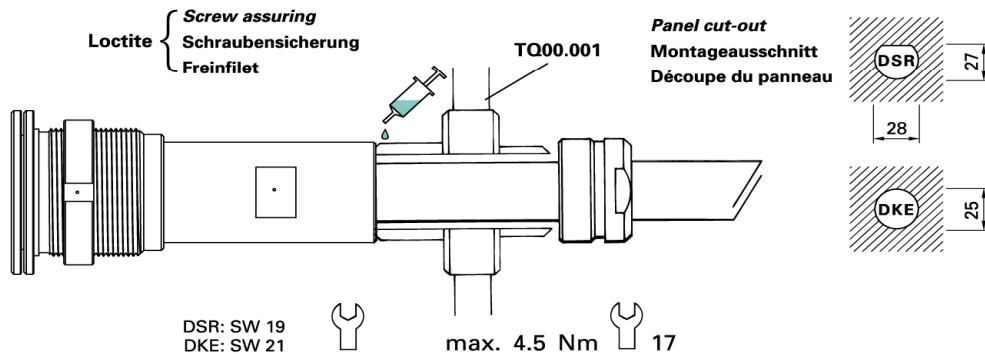
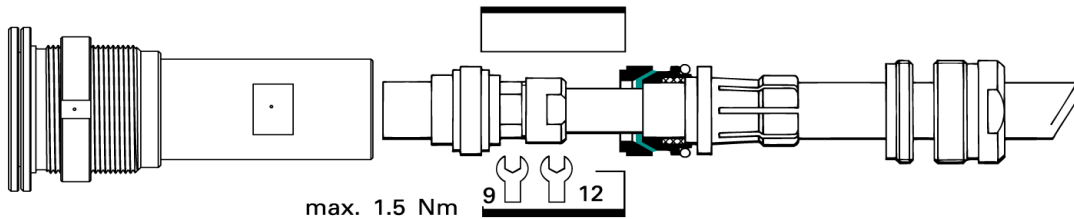
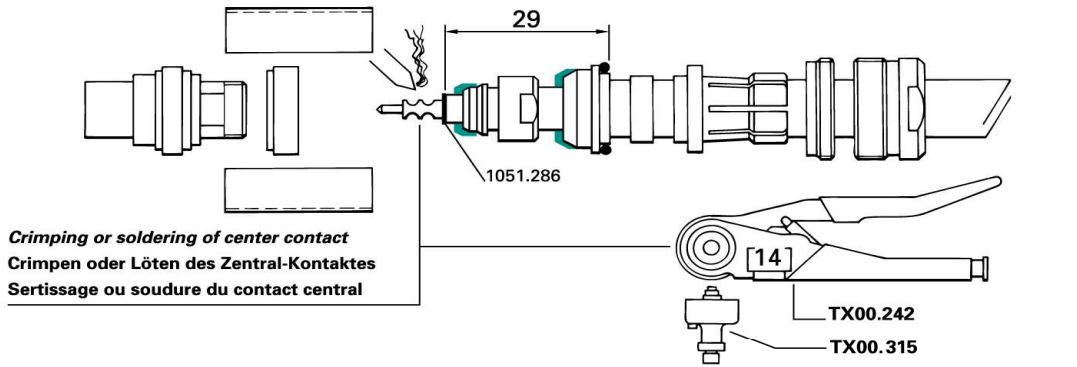

All dimension shown are in millimeters and are for reference only

For termination tooling see 1051 series catalogue version 4.0

### SE and KE 1051 A004-4 / DSR and DKE 1051 A004-4

REF.	A	B	L
SE + KE 1051 A004-4.2.1Ls/10s/15.2	27	5	13.5
DKE 1051 A004-4.2.1Ls/10s/15.2	27	7.5	13.5
DSR1051 A004-4.2.1Ls/10s/15.2	27	7.5	10.9
SE + KE 1051 A004-4 T1895/13.6	27	5	10.9
DSR + DKE 1051 A004-4 T1895/13.6	27	7.5	10.9

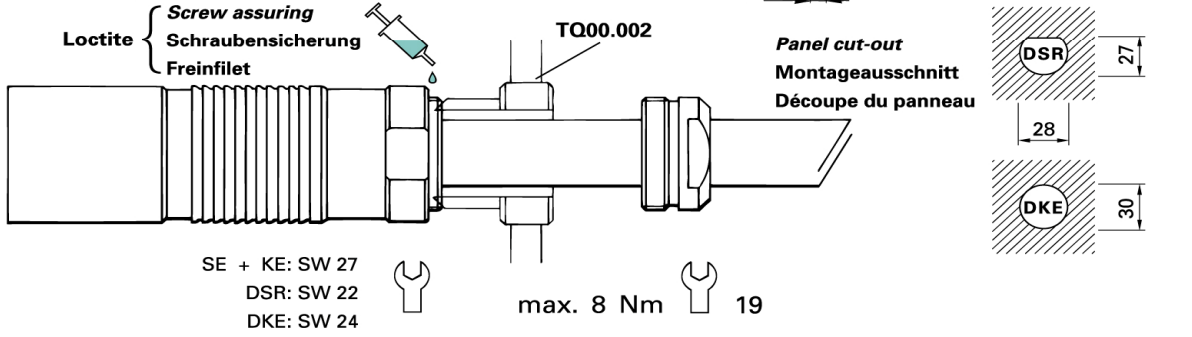
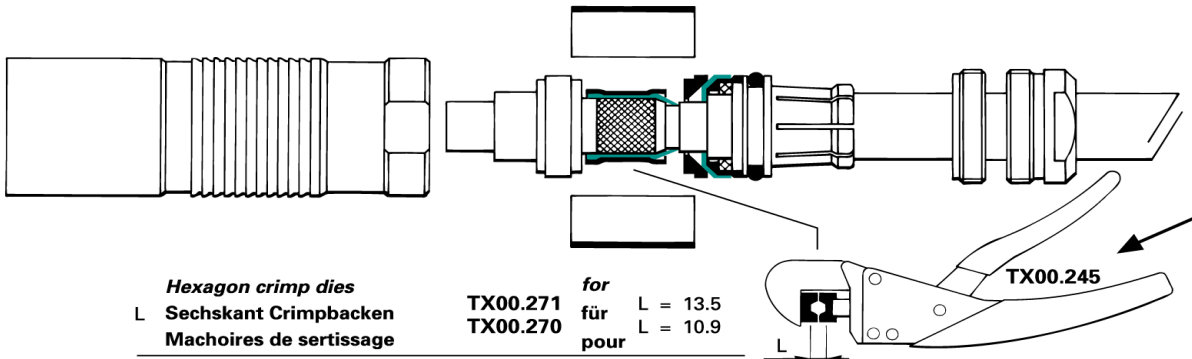
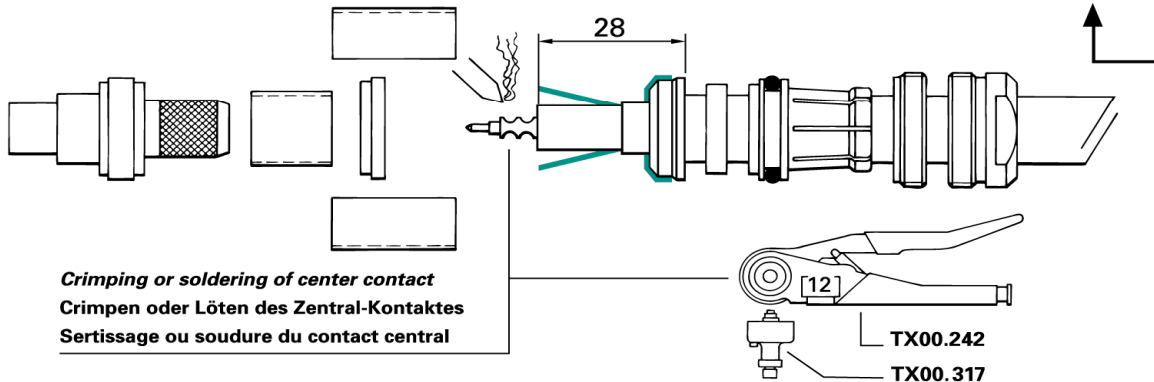
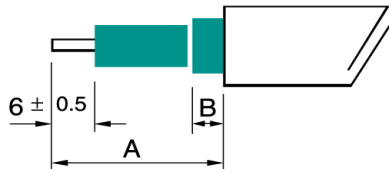

All dimension shown are in millimeters and are for reference only

For termination tooling see 1051 series catalogue version 4.0

## SE, KE, DSR and DKE 1051 A004-4 1.4/6.6/12.6

\* Add insulating washer for cable  
 Isolierscheibe einfügen für Kabel  
 Placer rondelle isolante pour câble

Triax 11  
 and  
 Triax 11/1  
 1.4/6.6/...

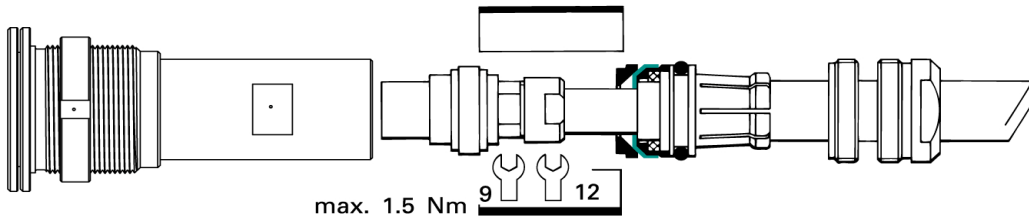
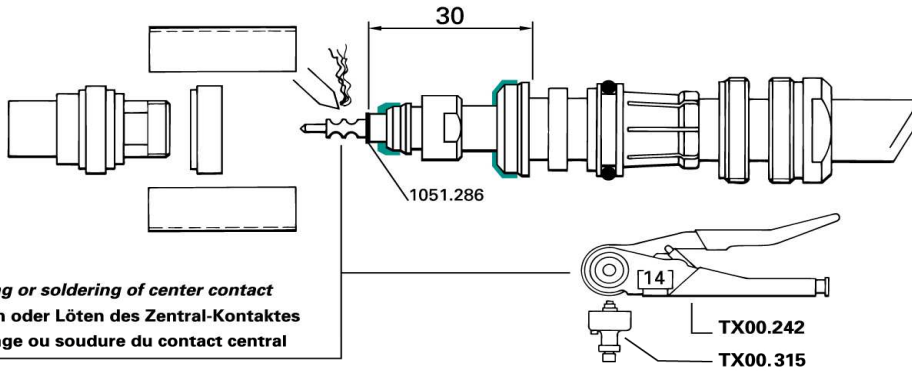
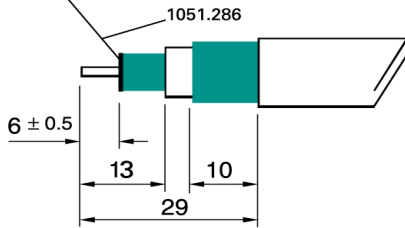

Loctite { Screw assuring  
 Schraubensicherung  
 Freinfilet

Panel cut-out  
 Montageausschnitt  
 Découpe du panneau

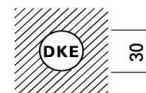
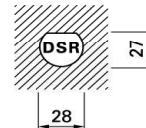
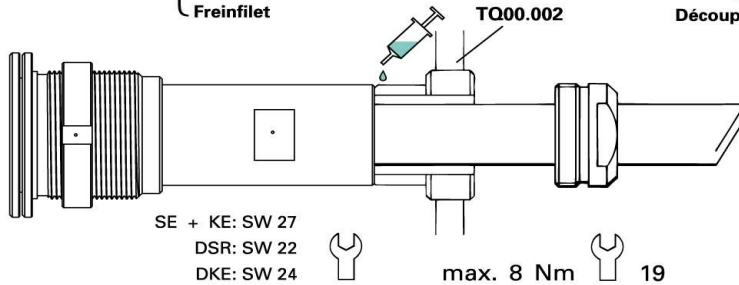

SE + KE: SW 27  
 DSR: SW 22  
 DKE: SW 24

For termination tooling see  
 1051 series catalogue version 4.0

All dimension shown are in millimeters and are for reference only