

SchuF Flush-Mounted Valves

Draining / Injection / Sampling



SchuF 

Table of Contents

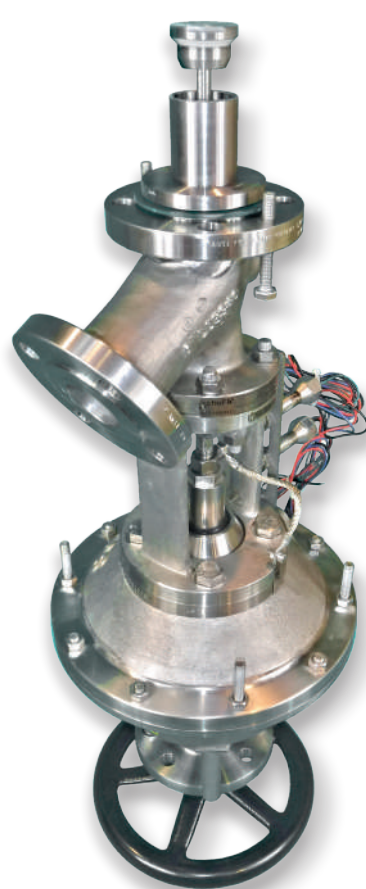

Page

SchuF Flush Mounted Valves- Introduction	3
Customer-driven design- Features & Options	4
Disc Flush-Mounted Drain Valves	5
Disc Drain Valves- Dimensions	10
Ram/Piston Flush-Mounted Drain Valves	14
Ram/Piston Drain Valves- Dimensions	18
SchuF-Fetterolf Ram-Seal Valves	20
SchuF-Fetterolf Ram-Seal Valves- Dimensions	22
SchuF-Fetterolf Rod-Seal Valves	23
SchuF-Fetterolf Rod-Seal Valves- Dimensions	25
Sampling Valves	26
Enquiry Sheet	38
SchuF Product Portfolio	39



SchuF is fully registered, accredited and certified worldwide

SchuF Worldwide Group

For over 100 years SchuF valves have stood for innovation and quality at the highest level.

SchuF invented the first bottom outlet valve over 100 years ago, and today, the SchuF Group offers flush-mounted valves with a disc or piston design in various materials and classes, with many options.

These valves are custom-manufactured to exact tolerances for use in specialised processes with often challenging operating conditions. SchuF Valves can be found in standard and severe service applications in the Chemical, Polymer, Pharma, Oil, Gas, Offshore and Refining industries. Continuing research and development in materials and design enable SchuF to offer valve solutions for applications with high pressure, high temperature and difficult media, or a combination of all three.

SchuF flush-mounted valves are ideal for draining tanks, reactors or pipelines containing both viscous and non-viscous media.



Right: A SchuF disc-rising pneumatically-actuated valve, as designed for the pharmaceutical industry, which incorporates P.A.T. technology

Why use a SchuF flush-mounted valve?

One of the most obvious benefits of a SchuF Valve is that of dead-space elimination. In the example below we can see how a SchuF valve is designed to perfectly match vessel dimensions. The use of a simple

ball-valve in such an installation (as seen in the near image), with associated serious dead-space issues, can lead to blockage of the outlet nozzle.



Customer-driven design

Flush-Mounted Valves- Features and Options	
Flush-Mounted Custom Seats	SchuF will use the exact nozzle/piping dimensions to design custom valve seats to eliminate dead-space.
Material Choice	Cast-steel, stainless steel, nickel-based alloys including Hastelloy®, Incolloy®, Inconel®, Monel®, plus Titanium, Zirconium and many others. Valve lining can be PTFE, PFA or glass. Hard-face options include Stellite, Tungsten Carbide, ceramic, etc.
Actuation	Options include electric, pneumatic, hydraulic or manual operation, possibly in combination.
Heating/Cooling Jackets	Jackets or shells offering heating or cooling.
Seal to Atmosphere	Stuffing-box with live-loaded packing and optional bellows seal.
Control & Automation	SchuF provides a wide range of instrumentation and flow control accessories
Flushing	SchuF valves can be supplied with system flushing or purging ports as required.
Sampling/Injection	Sampling and Injection ports can be supplied.
Fire-Safe	Fire-safe certification to BS 6755 Part 2 (1987), to ISO 10497, or to API 607. Fire-Safe Blankets are a further option.
Process Analytical Technology (P.A.T.)	A SchuF valve with integral P.A.T. sensor allows process monitoring with fully-immersed PAT probes such as FTIR (mid- and near-IR ranges), RAMAN, FBRM, PVM, ATR, LiquiSonic®, pH and turbidity probes.
Temperature Sensors	Temperature sensors mounted within the disc or ram/piston allow accurate monitoring of the vessel/reactor contents, even with small batches- removing any need for extra nozzle access while also allowing for fast probe removal.

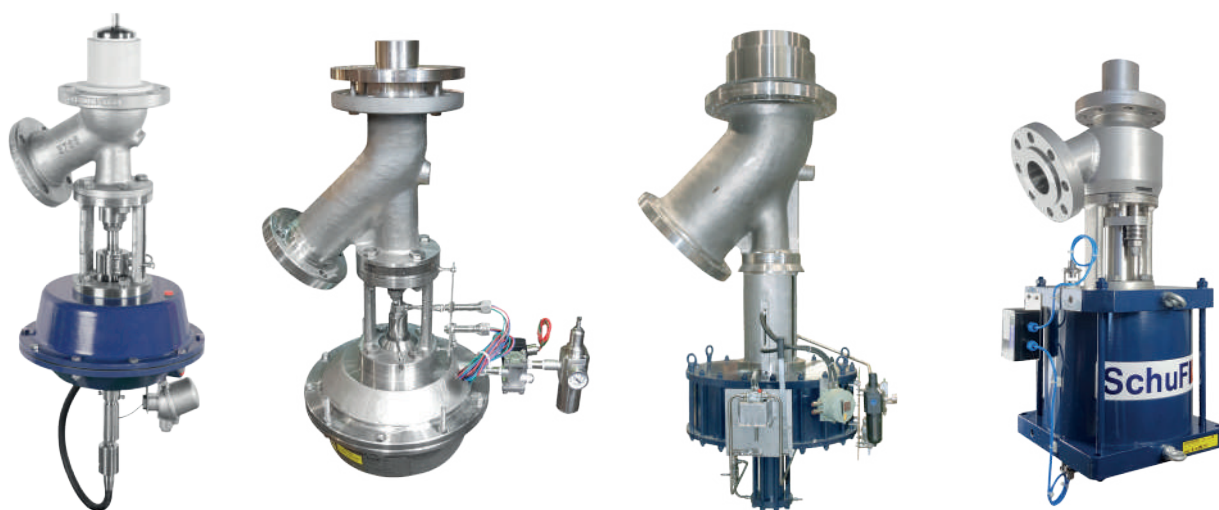

Disc Flush-Mounted Drain Valves

SchuF disc valves are available in both *Disc Raising* and *Disc Lowering* variants, each with advantages in certain vessel/pipe installation situations. Both types are also suitable for use as injection valves.

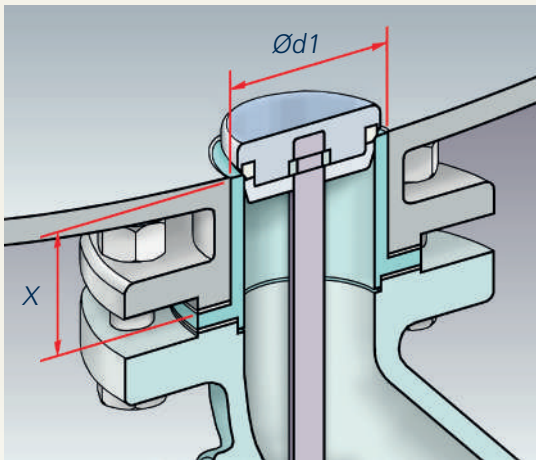

Type 25 (Disc Raising) valves utilise the vessel pressure forces to help seal the valve in a flow-to-close design, thereby requiring smaller actuator forces to achieve a seal, especially in high-pressure systems. Type 25 valves also provide a crust-breaking function.

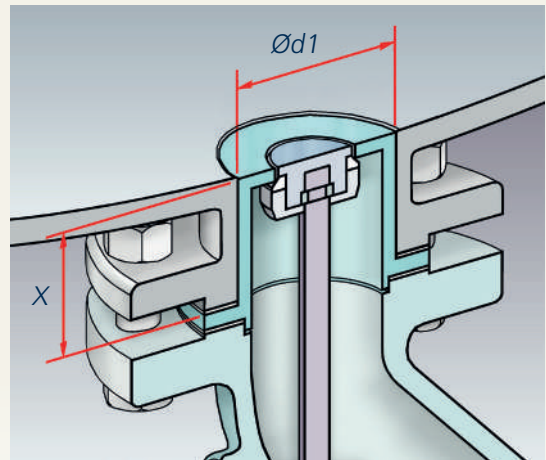

Type 24 (Disc Lowering) valves operate in a flow-to-open arrangement, and can be mounted on vessels where low-mounted agitators operate very close to the vessel bottom outlet.

There are a number of further seat arrangement options specific to both Type 24 & Type 25 valves. Please go to www.schuf.com or contact us for more details.



Left- a **Type 25** disc-rising valve, with spring-returned short-stroke pneumatic actuator, limit-switch accessories and manual override.



Right- a **Type 24** disc-lowering valve, also with a spring-returned short-stroke pneumatic actuator- note the actuator's opposite orientation to that of the Type 25 valve, left

Disc Flush-Mounted Drain Valves

Disc Bottom Outlet Valves are ideal when addressing the following process requirements:

- Lower stem-sealing forces are required
- There are space restrictions underneath the reactor
- Absolute tight shut-off to atmosphere is necessary (bellows-seal)
- Short travel is advantageous
- Low initial and maintenance costs are a factor
- The valve size is above 8"/DN200
- Flushing of the valve body cavity during reaction is desirable
- The valve is for lethal service

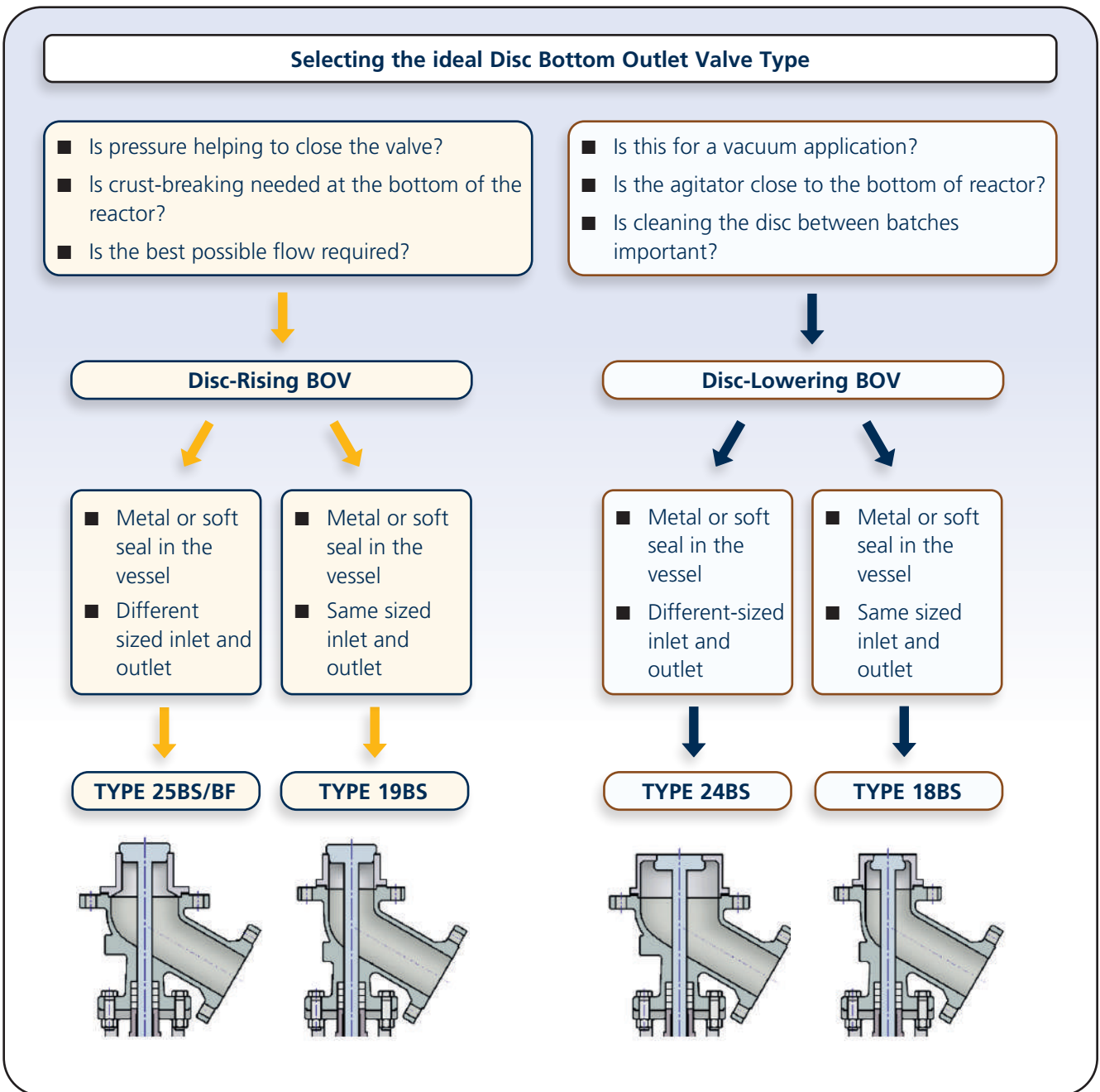

Disc Flush-Mounted Drain Valves

SchuF is the inventor (in 1923) of the Disc Bottom Outlet Valve. These valves are ideal for draining tanks, reactors or pipelines, and are widely used in the pharmaceutical, fine chemical, biochemical, and mineral-refining industries.

Key Features

- Dead-space-free nozzle connection
- Space- and weight-saving valve design due to short-stroke operation,
- Smaller, faster, lighter actuation
- Zero leakage-to-atmosphere options
- Options for fire-safe, crust-breaking, clean-in-place, sensors / P.A.T. (see SchuF Pharma brochure) and integral sampling available
- Wide variety of inlet and outlet connections can be supplied- flanged (all types/standards), threaded, welded, clamped, custom

Disc Options

In this example, we see a loose, self-centring, rising disc (see page 6), with soft sealing ring. Discs are also available with metal or hard-faced sealing surfaces.

For further details on this and other disc arrangements, please visit www.schuf.com or contact us for more details

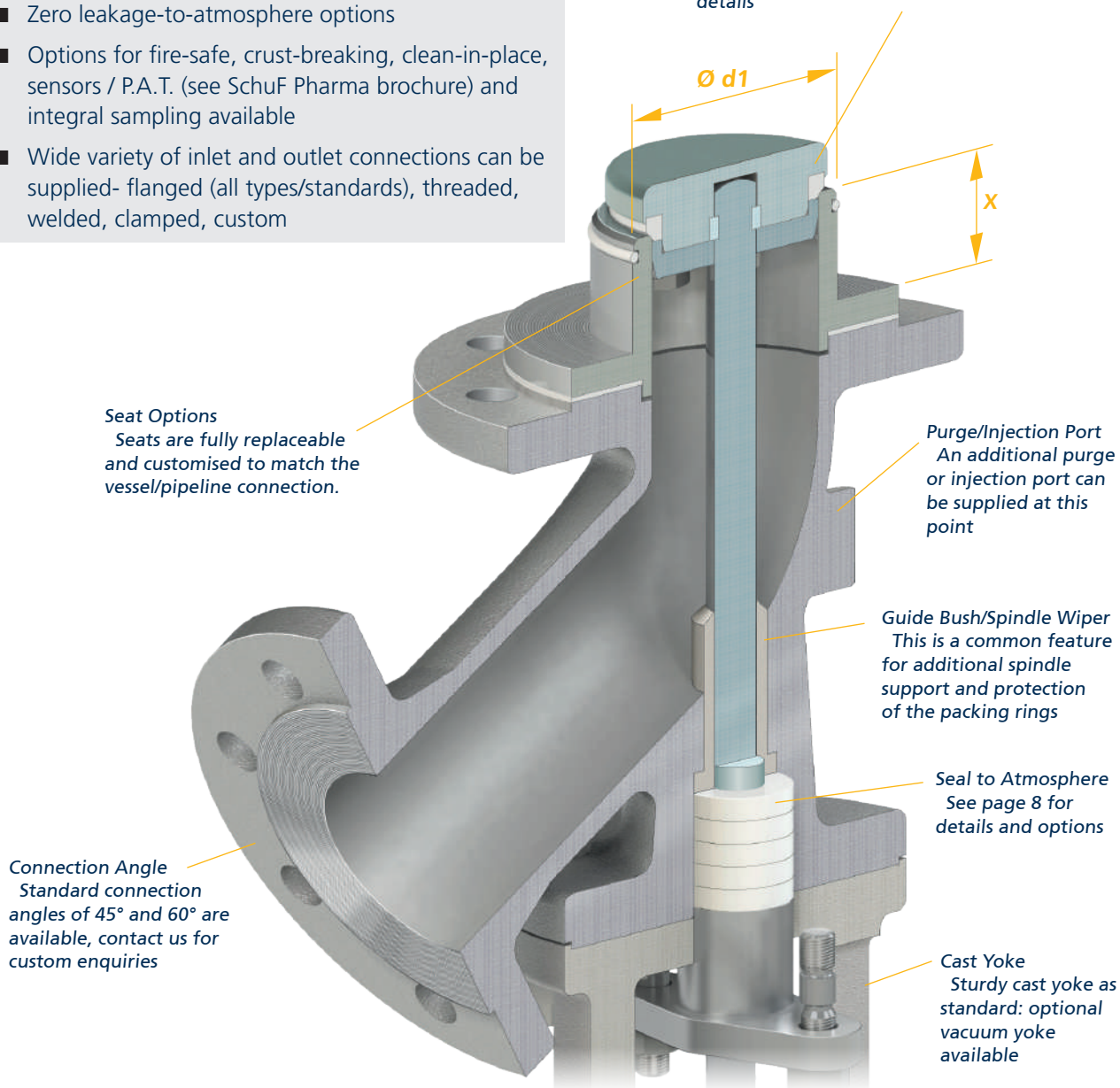

Seat Options

Seats are fully replaceable and customised to match the vessel/pipeline connection.

Purge/Injection Port
An additional purge or injection port can be supplied at this point

Guide Bush/Spindle Wiper
This is a common feature for additional spindle support and protection of the packing rings

Seal to Atmosphere
See page 8 for details and options

Connection Angle

Standard connection angles of 45° and 60° are available, contact us for custom enquiries

Cast Yoke
Sturdy cast yoke as standard: optional vacuum yoke available

Actuator

A wide variety of custom actuators is available, with options including electric, pneumatic, hydraulic and manual operation

Disc Flush-Mounted Drain Valves- Features and Options

Seal to Atmosphere

Minimising or even eliminating fugitive emissions to atmosphere is a highly important aspect of valve performance. All SchuF valves can be supplied with a number of different arrangements to suit any customer requirements in this area.

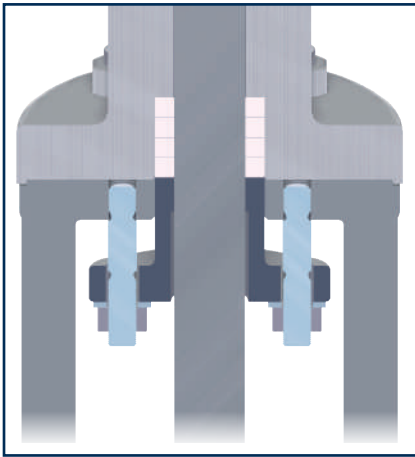

Standard Packing

Packing rings are compressed using a stuffing-box gland, which can be regularly tightened as required using standard studs/nuts

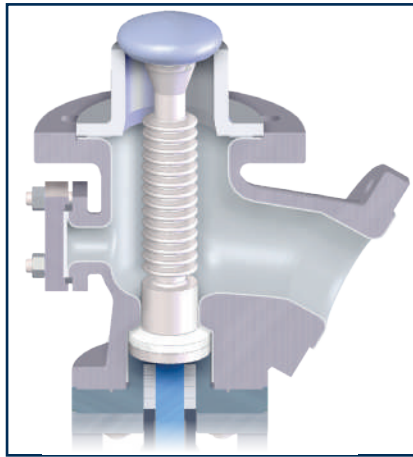

Bellows Seal

This utilises an expanding/contracting bellows (PTFE shown here; metal also available) and incorporates a back-up stuffing-box-seal section

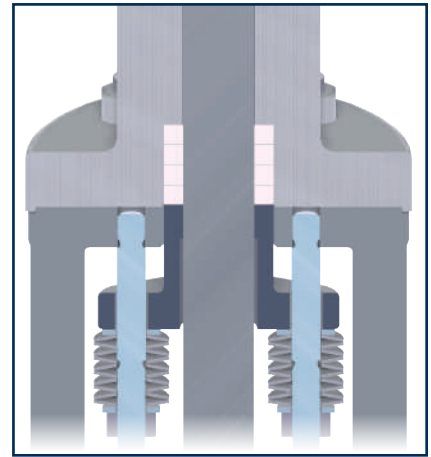

Live-Loaded Packing

Here, cup-springs are employed to maintain the required minimum sealing pressure, even as the packing-rings compress over time

Sensors and Process Analytical Technology [PAT]

- SchuF can provide sensor functionality in a number of ways, from basic temperature sensors to full PAT systems.
- A SchuF-patented Multiprobe valve with single-shaft design (below left) can utilise an Infra-Red PAT probe with an incorporated 1xPT100 (single-sensor) temperature sensor.
- The double-probe arrangement, below centre, can house a standard 2xPT100 (double-sensor) temperature sensor alongside a separate PAT probe.
- Other probe types (e.g. a *SensoTech Liquisonic*® probe, shown below, far right) are also available.

Right: SchuF Single-Shaft Multiprobe™ Disc Valve, DN50 / 2" or larger



Right: SchuF Double-Shaft Multiprobe™ Disc Valve, DN50 / 2" or larger



Right: SchuF Disc Valve with a *SensoTech Liquisonic*® probe.



For further details see brochure 'Valves for the Pharmaceutical and Fine Chemical Industries' at www.schuf.com

Disc Flush-Mounted Drain Valves- Special Options

Lined Valves

SchuF flush-mounted disc valves see extensive service in the bulk pharmaceutical and fine chemical industries. The Type 25 bottom-outlet valve with **lining in glass, PTFE/PFA, tantalum, or other materials such as rubber**, provides the ideal solution when customers require a flush-mounted, custom fitted valve with high corrosion resistance and complete operational reliability in order to maximise their system's high-level functionality. Bespoke design requirements can be incorporated into each valve alongside tried and tested standard design features, such as **elimination of dead-space in the vessel outlet, FDA and GMP compliance, full cleaning capability (Clean In Place, CIP) and fire-safe certification.**

These valves can be supplied with **bellows or stuffing-box seal to atmosphere.** Additional options include **temperature/PAT sensors**, accessories such as **positioners, limit switches or solenoid valves, actuator manual over-ride, leak detection and live-loaded packing.**



Above is an example of a low-profile glass-lined valve, with glass disc, PTFE/PFA seat, spring-returned short-stroke side-mounted pneumatic actuator, and internal temperature-sensor with connecting head



Above- two more examples of SchuF lined valves.
Near right, we see a valve with glass-lined body with PTFE bellows seal to atmosphere.
Further right, a valve with PTFE/PFA-lined body and glass-lined spindle, stuffing-box seal to atmosphere, and temperature sensor with integral connecting head.

Filter Valve

SchuF has developed a disc-rising drain valve with the ability to measure real-time process reaction parameters while utilising fine-control multi-level filtering in order to achieve specific product crystallisation dimensions. This functionality may otherwise only have been obtainable by utilising a set of reactors and separators in a costly and lengthy process



Disc Valves- Standard Dimension Sheets

All dimensions in mm

Disc-Rising Type 19/25 Valve, Pneumatic Actuator with Manual Override

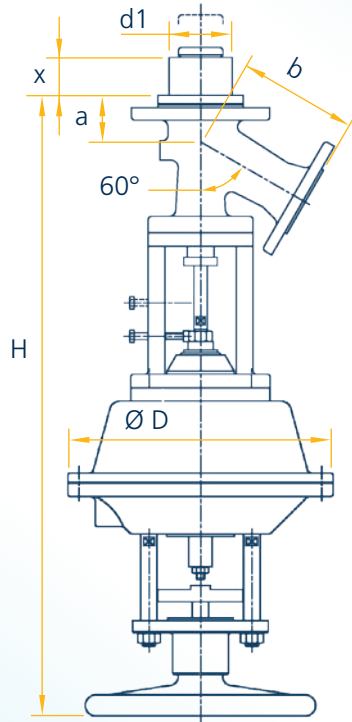

Rating and variable Valve Size ↓	PN16				PN25/40			
	a	b	H	Ø D	a	b	H	Ø D
DN 25/25	50	108	682	315	52	110	684	315
DN 40/25	70	110	692	315	85	140	732	315
DN 40/40	54	140	733	315	56	142	735	315
DN 50/25	85	138	732	315	87	140	734	315
DN 50/50	62	145	749	315	62	145	749	315
DN 80/50	62	145	749	315	66	146	758	315
DN 80/80	75	180	802	315	76	180	803	315
DN 100/80	68	180	805	315	66	204	813	315
DN 100/100	79	197	838	390	82	200	838	390
DN 125/100	81	197	844	390	84	200	840	390
DN 150/100	72	197	840	390	78	201	846	390
DN 150/150	94	237	900	402	116	274	968	450
DN 200/150	85	237	896	402				

Rating and variable Valve Size ↓	ASME 150				ASME 300			
	a	b	H	Ø D	a	b	H	Ø D
1"/1"	48	106	680	315	52	110	684	315
1½"/1"	85	135	732	315	88	139	735	315
2"/1"	86	135	733	315	89	139	736	315
1½"/1½"	54	140	736	315	59	149	757	315
2"/1½"	55	140	737	315	60	149	758	315
2"/2"	61	144	748	315	64	147	754	315
3"/2"	66	145	758	315	72	147	758	315
3"/3"	76	180	803	315	81	185	808	315
4"/3"	72	184	809	315	74	209	806	315
4"/4"	82	200	838	390	90	208	846	390
6"/4"	76	201	841	390	87	209	855	390
6"/6"	97	240	893	450	127	285	977	450
8"/6"	90	238	924	450	103	250	937	450

Disc-Rising Type 25 Valve, Lined Body with 60° Outlet and Side-Mounted Pneumatic Actuator

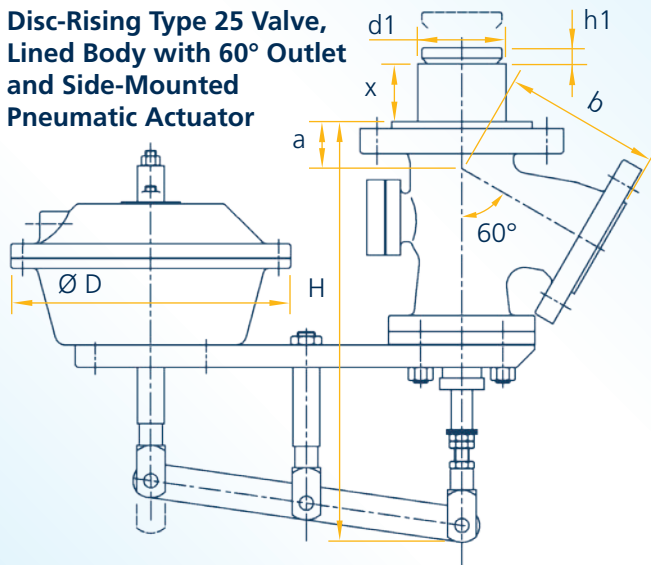

Valve Size; Metric / Imperial Variable ↓	50/40	80/50	100/80	150/100	200/150
	2"/1½"	3"/2"	4"/3"	6"/4"	8"/6"
x (standard)	50	52	66	81	100
d1 (standard)	49	79	99	148	198
x min/max	30 - 75	52 - 100	66 - 150	81 - 180	40 - 180
a	94	57	55	75	110
b	160	167	180	200	240
h1	17	18	25	23	42
H (PS)	475	480	480	500	700
Stroke	30	35	40	40	60
Ø D	315	315	315	315	390

Disc Valves- Standard Dimension Sheets

All dimensions in mm

Disc-Rising Type 25 Valve, Lined Body with 45° Outlet and Side-Mounted Pneumatic Actuator

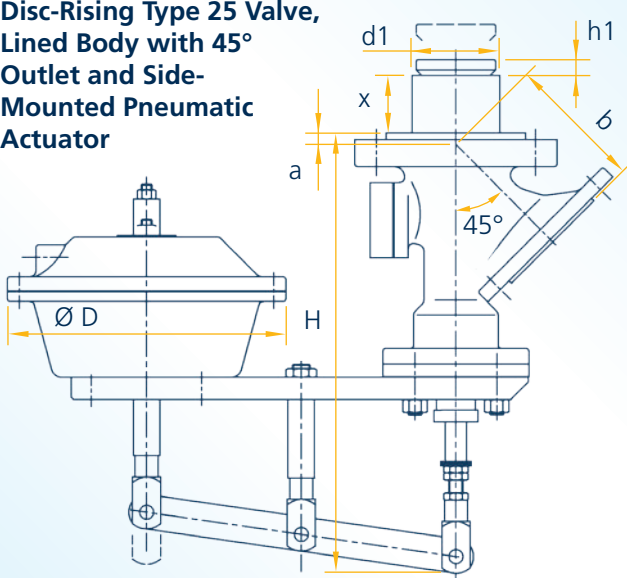

Valve Size; Metric / Imperial →	50/40	80/50	100/80	150/100	200/150
Variable ↓	2"/1½"	3"/2"	4"/3"	6"/4"	8"/6"
x (standard)	50	52	66	81	100
d1 (standard)	49	79	99	148	198
x min/max	30 - 75	52 - 100	66 - 150	81 - 180	40 - 180
a	43	14	14	14	65
b	160	115	155	175	330
h1	17	18	25	23	42
H (PS)	475	480	510	550	675
Stroke	30	35	40	40	60
Ø D	315	315	315	315	390

Disc-Lowering Type 18/24 Valve, Pneumatic Actuator with Manual Override

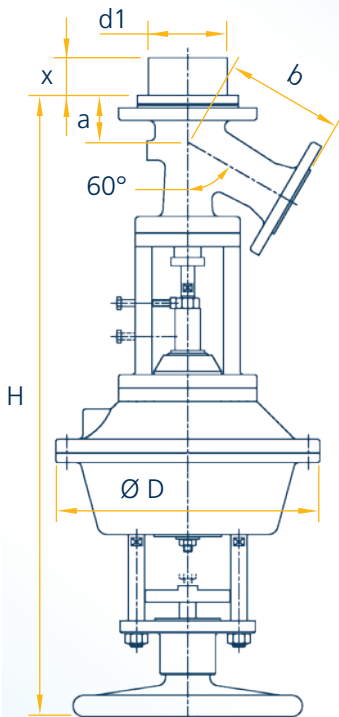

Rating and variable Valve Size ↓	PN16				PN25/40			
	a	b	H	Ø D	a	b	H	Ø D
DN 40/25	70	110	709	315	85	140	749	315
DN 50/25	85	138	749	315	87	140	751	315
DN 40/40	54	140	750	315	56	142	752	315
DN 50/40	56	144	771	315	58	146	773	315
DN 50/50	62	145	766	315	50	145	766	315
DN 80/50	62	145	766	315	66	146	775	315
DN 80/80	75	180	836	390	76	180	837	390
DN 100/80	68	180	839	450	66	204	847	390
DN 100/100	79	197	855	450	82	200	855	450
DN 150/100	72	197	857	450	78	201	863	450
DN 150/150	94	237	917	450	116	274	985	450
DN 200/150	85	237	913	450				

Rating and variable Valve Size ↓	ASME 150				ASME 300			
	a	b	H	Ø D	a	b	H	Ø D
1½"/1"	85	135	749	315	88	139	752	315
2"/1"	86	135	750	315	89	139	753	315
1½"/1½"	54	140	753	315	59	149	774	315
2"/1½"	55	140	754	315	60	149	775	315
2"/2"	61	144	765	315	64	147	771	315
3"/2"	66	145	775	315	72	147	775	315
3"/3"	76	180	837	390	81	185	842	390
4"/3"	72	184	843	390	74	209	840	390
4"/4"	82	200	855	450	90	208	863	450
6"/4"	76	201	858	450	87	209	872	450
6"/6"	97	240	910	450	127	285	994	450
8"/6"	90	238	941	450	103	250	954	450

Disc Valves- Standard Dimension Sheets

All dimensions in mm

Disc-Rising Type 19/25 Valve, Manual Actuator

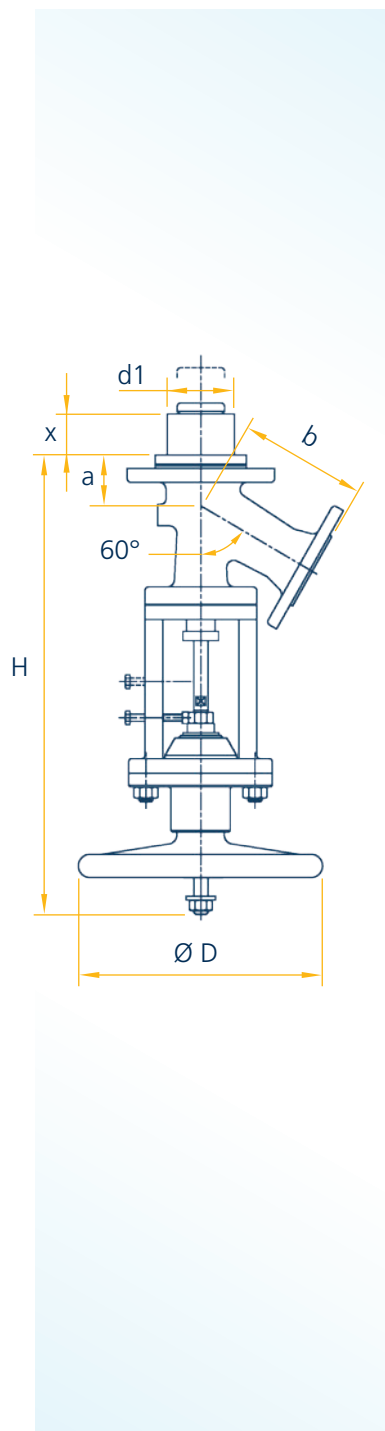

Rating and variable Valve Size → ↓	PN16				PN25/40			
	a	b	H	Ø D	a	b	H	Ø D
DN 40/25	70	110	345	120	85	140	381	120
DN 50/25	85	138	381	120	87	140	383	120
DN 40/40	52	138	372	160	54	140	374	160
DN 50/40	56	144	395	160	58	146	397	160
DN 50/50	62	145	383	160	62	145	386	160
DN 80/50	62	145	383	160	66	146	387	160
DN 80/80	75	180	466	225	76	180	460	225
DN 100/80	68	180	465	225	66	204	475	225
DN 100/100	79	197	478	225	82	200	476	225
DN 150/100	72	197	483	225	78	201	486	225
DN 150/150	94	237	585	280	128	276	627	280
DN 200/150	85	237	572	280				

Rating and variable Valve Size → ↓	ASME 150				ASME 300			
	a	b	H	Ø D	a	b	H	Ø D
1"/1"	48	106	327	120				
1½"/1"	85	135	382	120	88	139	367	120
2"/1"	86	135	383	120	89	139	368	120
1½"/1½"	54	140	372	160	59	149	372	160
2"/1½"	55	140	373	160	60	149	374	160
2"/2"	61	144	385	160	64	147	370	160
3"/2"	66	145	387	160	72	147	374	160
3"/3"	76	180	460	225	80	184	439	225
4"/3"	72	184	469	225	74	209	453	225
4"/4"	82	200	476	225	90	208	459	225
6"/4"	76	201	483	225	87	209	470	225
6"/6"	97	240	583	225	127	285	612	280
8"/6"	90	238	596	225	103	250	573	280

Disc Valves- Standard Dimension Sheets

All dimensions in mm

Disc-Lowering Type 18/24 Valve, Manual Actuator

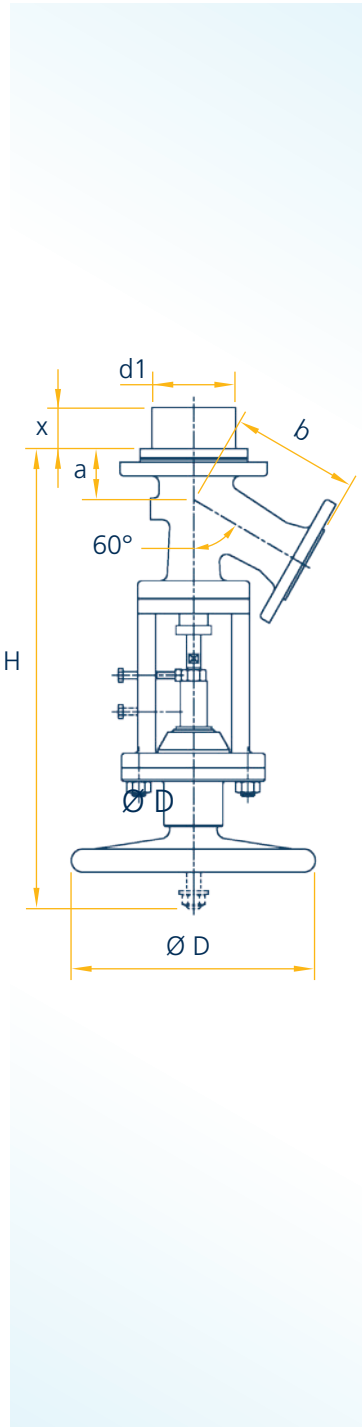

Rating and Valve Size → ↓	PN16				PN25/40			
	a	b	H	Ø D	a	b	H	Ø D
DN 25/25	50	108	682	500	50	108	682	500
DN 40/25	70	110	692	750	70	110	692	750
DN 40/40	54	140	733	1000	54	140	733	1000
DN 50/40	56	144	754	1000	56	144	754	1000
DN 50/50	62	145	749	1000	62	145	749	1000
DN 80/50	62	145	749	1100	62	145	749	1100
DN 80/80	75	180	802	1200	75	180	802	1200
DN 100/80	68	180	805	1200	68	180	805	1200
DN 100/100	79	197	838	1500	79	197	838	1500
DN 125/100	81	197	844	1500	81	197	844	1500
DN 125/125	90	222	862	1700	90	222	862	1700
DN 150/150	94	237	900	1700	94	237	900	1700
DN 200/150	85	237	896	2200	85	237	896	2200

Rating and Valve Size → ↓	ASME 150				ASME 300			
	a	b	H	Ø D	a	b	H	Ø D
1½"/1"	50	108	682	500	50	108	682	500
2"/1"	70	110	692	750	70	110	692	750
1½"/1½"	54	140	733	1000	54	140	733	1000
2"/1½"	56	144	754	1000	56	144	754	1000
2"/2"	62	145	749	1000	62	145	749	1000
3"/2"	62	145	749	1100	62	145	749	1100
3"/3"	75	180	802	1200	75	180	802	1200
4"/3"	68	180	805	1200	68	180	805	1200
4"/4"	79	197	838	1500	79	197	838	1500
6"/4"	81	197	844	1500	81	197	844	1500
6"/6"	90	222	862	1700	90	222	862	1700
8"/6"	94	237	900	1700	94	237	900	1700

Ram/Piston Flush-Mounted Drain Valves

Ram/Piston Bottom Outlet Valves are ideal when addressing the following process requirements:

- Is it necessary to have full-bore flow through the drain valve?
- Is the nominal bore of the valve 1" or smaller?
- Can deposits on the seat of the valve be a problem?
- Is sampling before vessel-draining necessary?

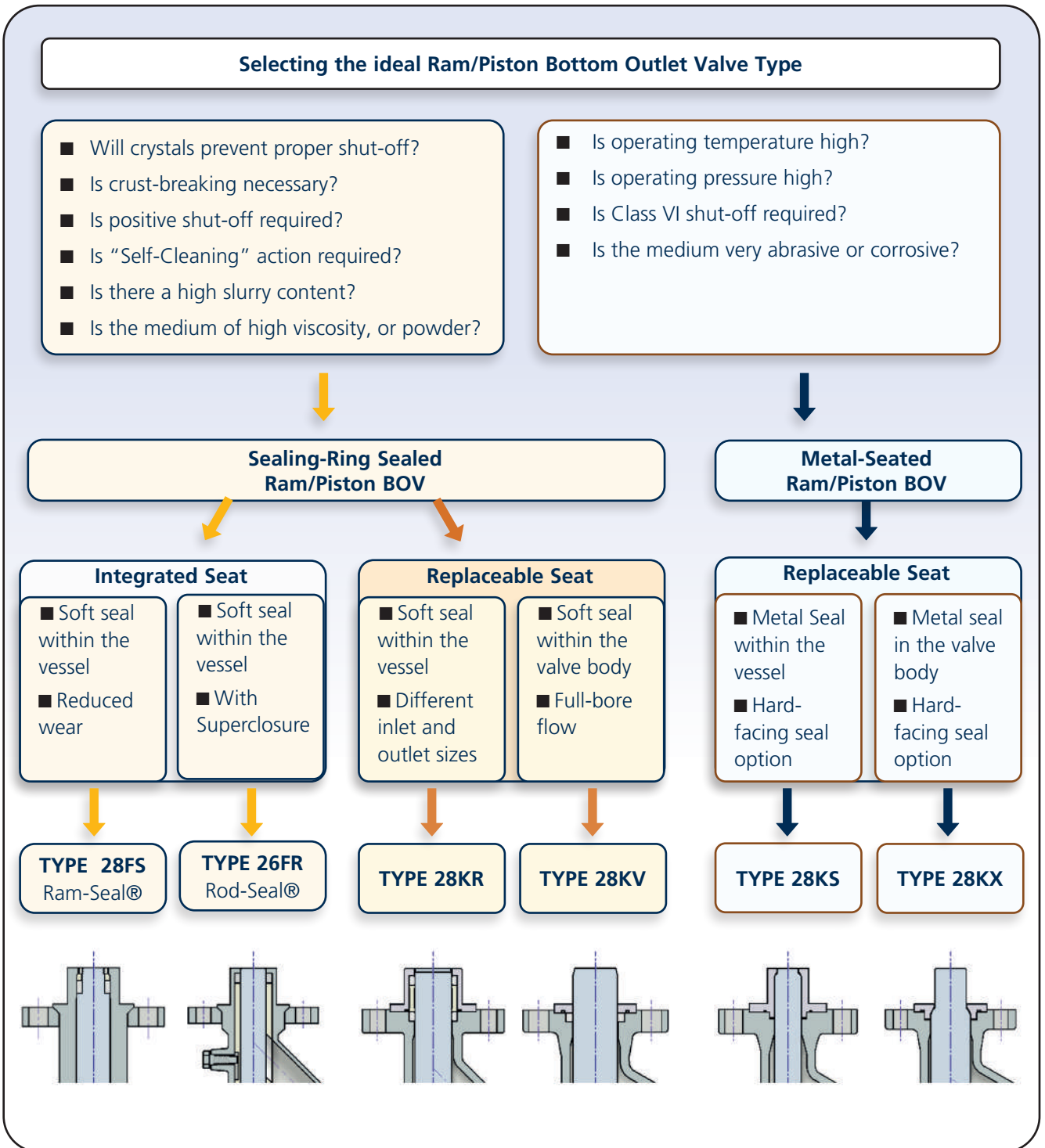

Ram/Piston Flush-Mounted Drain Valves

SchuF is the inventor of the Ram/Piston Bottom Outlet Valve (1926). These valves are most commonly used to quickly drain or inject media into or out of vessels, tanks, reactors or pipelines, and are especially effective in handling high-viscosity media and slurry flow through smaller bores.

Key Features

- Dead-space-free nozzle connection
- Full-bore flow allows for rapid vessel drainage
- Zero leakage-to-atmosphere options
- Options for fire-safe, crust-breaking, sensors (P.A.T.) and sampling available

Seat Options

Seats are fully replaceable and customised to match the vessel/pipeline connection. The vessel bore is matched using the variable $\varnothing d1$, and the depth of seat insertion is referenced as X. For further seat/connection options, see page 16

Ram/Piston Sealing Methods

In this example, we see a metal-to-metal seat. Rams/Pistons are also available with soft sealing surfaces. For other sealing arrangements, see also pages 16 & 17

Purge/Injection Port

An additional purge or injection port can be supplied at this point

Seal to Atmosphere

Stuffing-box gland arrangements, such as the one shown here, can be supplied with packing rings in a variety of materials and in different configurations. This example shows an extended packing ring arrangement.

For further options see www.schuf.com

Connection Angle

Standard connection angles of 45° and 60° are available- contact us for custom enquiries

Cast Yoke

Sturdy cast yoke as standard: optional vacuum yoke available

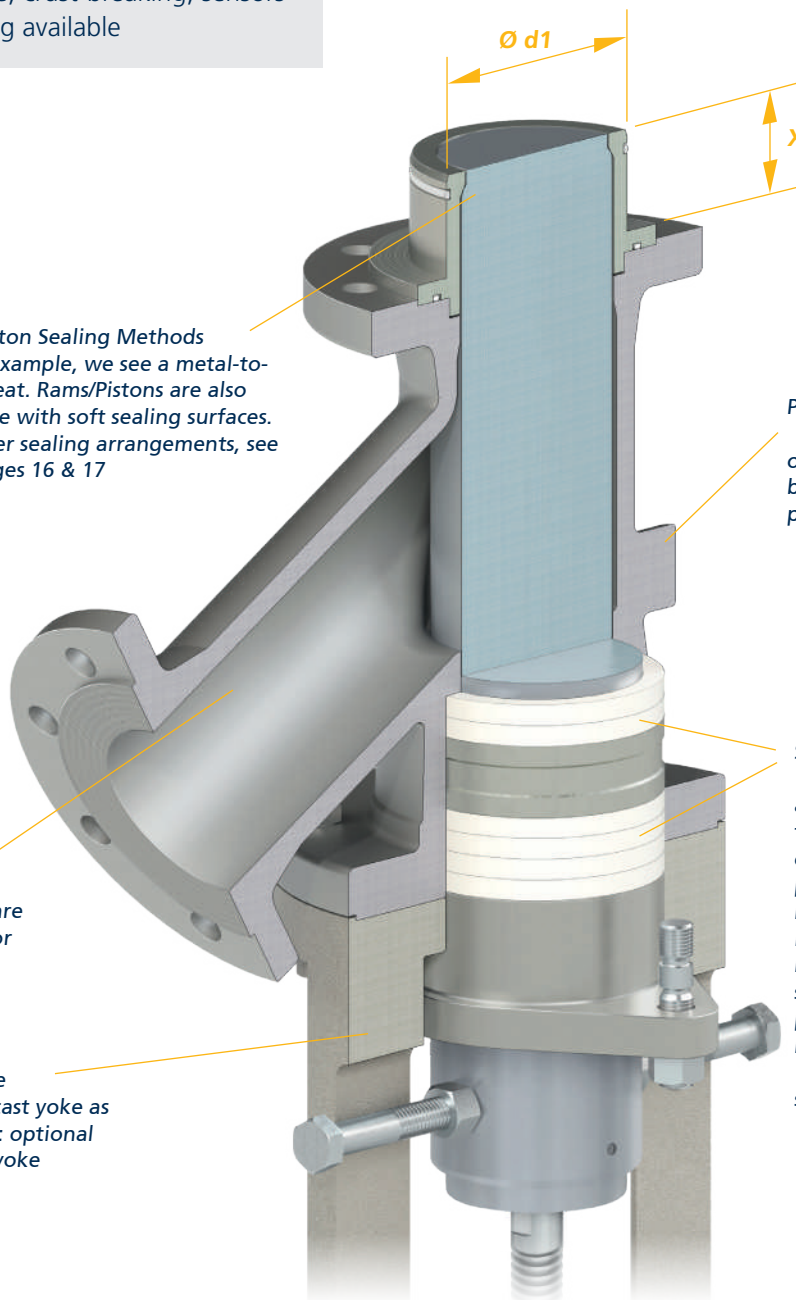

Actuator

A wide variety of custom actuators is available, with options including electric, pneumatic, hydraulic and manual operation

Ram/Piston Flush-Mounted Drain Valves- Sealing Options

SchuF Rams/Pistons are available with different seal-to-process options, such as soft-seal (using a radial sealing ring) or metal-to-metal seal. A further option is a hard-faced metal-to-metal seal.

Replaceable Seats

Metal or hard-faced seal (Below): This type of sealing arrangement is particularly suited for applications involving severe service with abrasive, corrosive, or dirty media, including slurries, as well as for processes involving extreme temperatures or high-pressure conditions. Seats are fully customised and replaceable. A variety of hard-faced materials for use on wetted surfaces is available to extend service life.

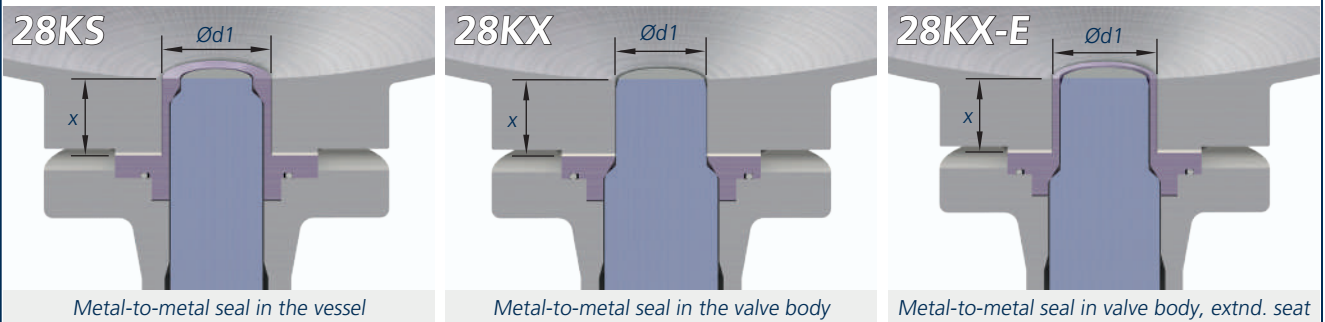

Soft Seal (Below): Valves with a soft-seal arrangement have the advantage of providing very good sealing performance (up to class VI) for competitive cost, due to smaller actuation requirements. In addition, this seal type can provide long valve-seat service life with low maintenance requirements. Seats are fully customised and replaceable. A wide variety of sealing ring materials is available to suit particular customer requirements.

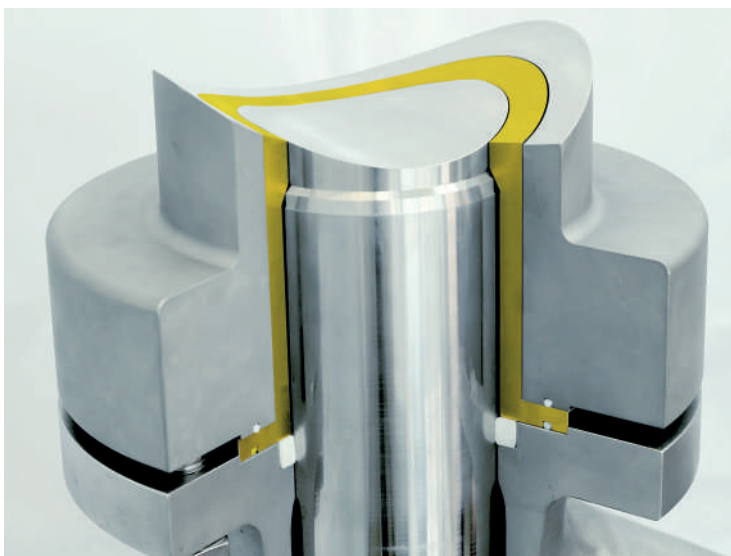
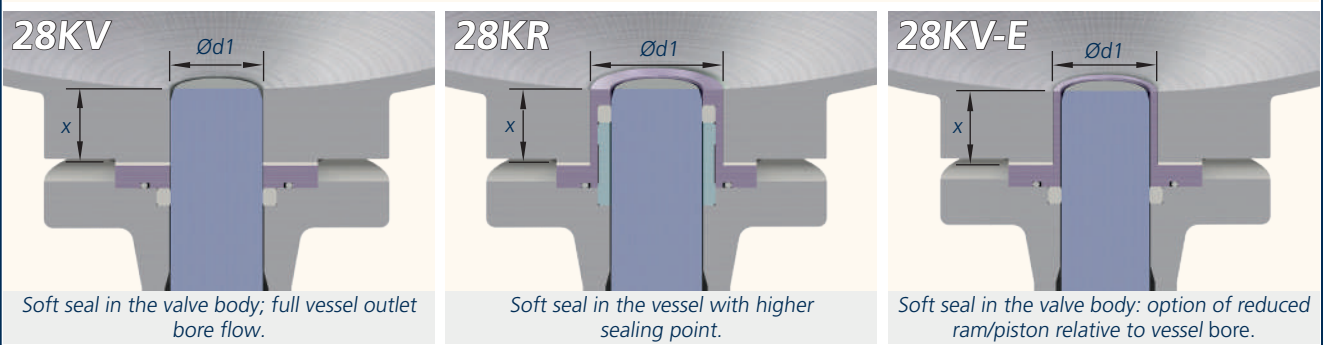

Left: A cutaway view of a Type 28 metal-to-metal sealing ram/piston valve, with weld-on nozzle/insert containing the seat (yellow), contoured to match the internal bore of a pipeline

Below: SchuF ram/piston valves can also incorporate temperature sensors (with or without additional PAT sensors) as required (see page 8 for further PAT info)

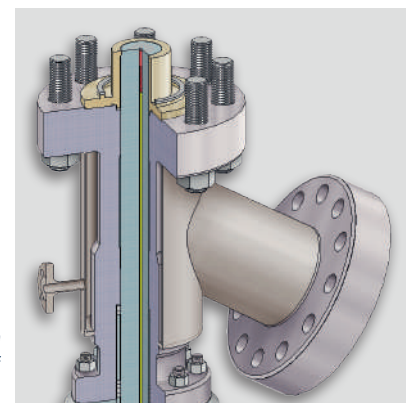

Ram/Piston Flush-Mounted Drain Valves- Features, Options

Seal to Atmosphere

The seal-to-atmosphere options listed for disc valves on page 8 also apply to ram/piston valves, except for bellows-sealed types. In addition, ram/piston valves can be supplied with further custom options, below, designed to match process requirements where ram/piston valves already provide the best solution.

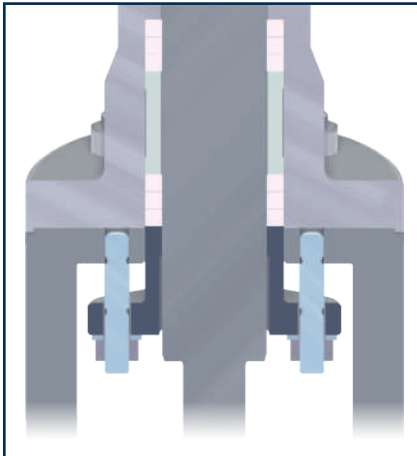

Extended Packing

A lantern (spacer) ring will create an extended-length packing arrangement which reduces dead-space and increases ram/piston travel stability

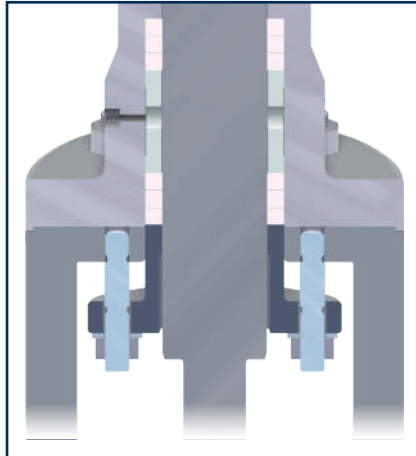

Extended Packing & Leak Detection

As left, but with an additional sniffer/sampling port behind the external sealing ring set to help identify leaks in the upper/inner set

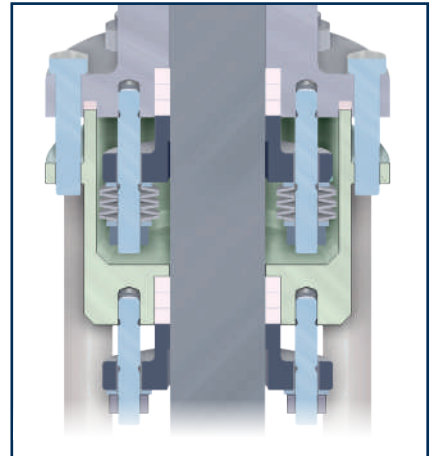

Double-Stuffing-Box

Two entirely separate layers of isolation can be provided, with the internal separately-tightened stuffing box utilising live-loaded packing

Below: An example of a pneumatically-actuated Type-28KS ram/piston valve. A cast yoke provides rigid support and an integral T-Piece allows installation into pipelines without introducing dead-space issues



Below: SchuF has a proven track record in providing valves to exacting Fire-Safe standards. This is an example of a Fire Blanket being utilized to protect the valve actuator and its ability to close in the event of fire



Above: A Type 28KS ram/piston valve with custom replaceable seat, featuring a manual bevel-gear actuator



Ram/Piston Valves- Standard Dimension Sheets

All dimensions in mm

Ram/Piston Type 28 Valve, Pneumatic Actuator (PKD - double-acting, air supply 4-6 bar/60-90psi)

ASME 150 / PN16

Rating and Variable Valve Size → ↓	a		b		≈ H	Stroke	Ø PKD	Ø D
	ASME 150	PN16	ASME 150	PN16				
1"/DN25	59	61	149	151	580+x	76+x	160	200
1½"/ DN40	88	86	194	192	730+x	122+x	160	200
2"/ DN50	89	88	209	208	745+x	122+x	160	200
3"/DN80	99	95	244	240	830+x	159+x	200	230
4"/DN100	99	95	269	265	870+x	174+x	250	280
6"/DN150	125	122	325	322	1070+x	254+x	320	355

ASME 300 / PN25

Rating and Variable Valve Size → ↓	a		b		≈ H	Stroke	Ø PKD	Ø D
	ASME 300	PN25	ASME 300	PN25				
1"/DN25	63	63	153	153	590+x	80+x	160	200
1½"/ DN40	91	88	197	194	740+x	125+x	160	200
2"/ DN50	92	90	212	210	755+x	125+x	160	200
3"/DN80	103	99	248	244	840+x	163+x	200	230
4"/DN100	107	99	277	269	880+x	182+x	250	280
6"/DN150	137	128	337	328	1100+x	266+x	400	445

ASME 600 / PN40

Rating and Variable Valve Size → ↓	a		b		≈ H	Stroke	Ø PKD	Ø D
	ASME 600	PN40	ASME 600	PN40				
1"/DN25	63	63	159	153	590+x	80+x	160	200
1½"/ DN40	92	88	205	194	740+x	126+x	160	200
2"/ DN50	95	90	222	210	760+x	128+x	200	230
3"/DN80	107	99	258	244	850+x	167+x	320	355
4"/DN100	113	99	290	269	895+x	188+x	320	445
6"/DN150	148	128	354	328	1120+x	277+x	500	560

ASME 900 / PN63

Rating and Variable Valve Size → ↓	a		b		≈ H	Stroke	Ø PKD	Ø D
	ASME 900	PN63	ASME 900	PN63				
1"/DN25	73	69	170	159	610+x	90+x	160	200
1½"/ DN40	102	96	214	202	760+x	136+x	200	230
2"/ DN50	108	96	235	216	785+x	141+x	200	230
3"/DN80	113	103	265	248	860+x	173+x	320	355
4"/DN100	119	105	296	275	910+x	194+x	400	445
6"/DN150	156	136	362	336	1140+x	285+x	550	610

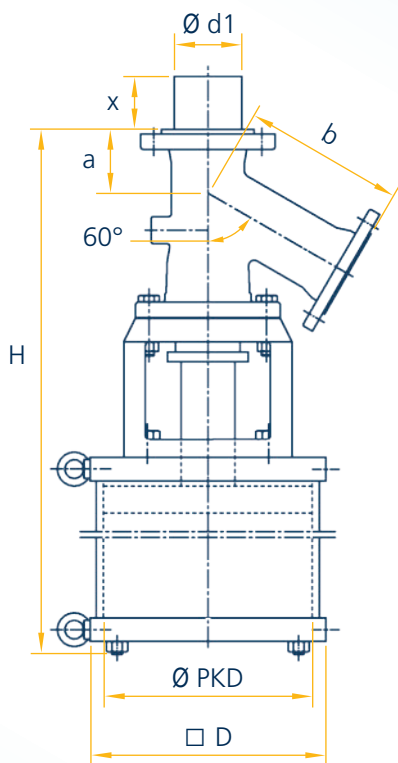

Ram/Piston Valves- Standard Dimension Sheets

All dimensions in mm

Ram/Piston Type 28 Valve, Manual [NF] Bevel Gear [KU] or Electric [EM] Actuator

ASME 150 / PN16

Rating and Variable Valve Size → ↓	a		b		≈H	≈H1	c	Ø D
	ASME 150	PN16	ASME 150	PN16				
1"/DN25	59	61	149	151	675+x	505+2x	500	225
1½"/ DN40	88	86	194	192	775+x	560+2x	500	225
2"/ DN50	89	88	209	208	900+x	825+2x	500	280
3"/DN80	99	95	244	240	1020+x	995+2x	515	360
4"/DN100	99	95	269	265	1040+x	1030+2x	515	360
6"/DN150	125	122	325	322	1170+x	1255+2x	540	560

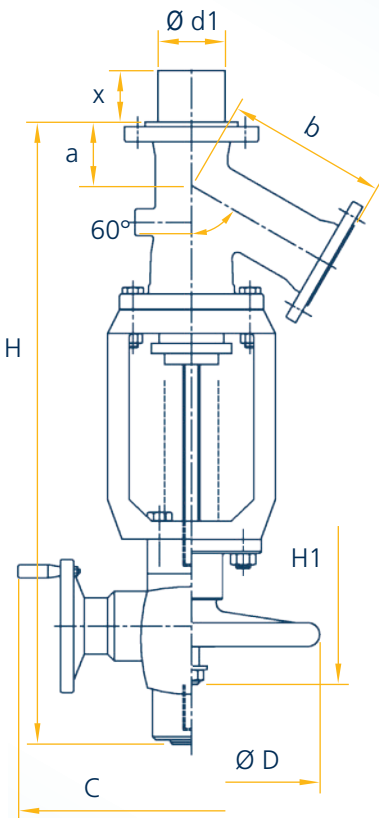

ASME 300 / PN25

Rating and Variable Valve Size → ↓	a		b		≈H	≈H1	c	Ø D
	ASME 300	PN25	ASME 3050	PN25				
1"/DN25	63	63	153	153	680+x	510+2x	500	225
1½"/ DN40	91	88	197	194	780+x	665+2x	500	225
2"/ DN50	92	90	212	210	910+x	835+2x	500	280
3"/DN80	103	99	248	244	1030+x	1000+2x	515	360
4"/DN100	107	99	277	269	1050+x	1050+2x	540	360
6"/DN150	137	128	337	328	1240+x	1280+2x	710	560

ASME 600 / PN40

Rating and Variable Valve Size → ↓	a		b		≈H	≈H1	c	Ø D
	ASME 600	PN40	ASME 600	PN40				
1"/DN25	63	63	159	153	680+x	510+2x	500	225
1½"/ DN40	92	88	205	194	785+x	670+2x	500	225
2"/ DN50	95	90	222	210	910+x	840+2x	515	280
3"/DN80	107	99	258	244	1030+x	1015+2x	540	360
4"/DN100	113	99	290	269	1100+x	1065+2x	710	560
6"/DN150	148	128	354	328	1250+x	1330+2x	720	800

ASME 900 / PN63

Rating and Variable Valve Size → ↓	a		b		≈H	≈H1	c	Ø D
	ASME 900	PN63	ASME 900	PN63				
1"/DN25	73	69	170	159	700+x	530+2x	500	225
1½"/ DN40	102	96	214	202	805+x	690+2x	515	225
2"/ DN50	108	96	235	216	920+x	865+2x	515	280
3"/DN80	113	103	265	248	1090+x	1030+2x	710	360
4"/DN100	119	105	296	275	1120+x	1080+2x	710	560
6"/DN150	156	136	362	336	1270+x	-	720	-

SchuF Fetterolf Ram/Piston Valves: Ram-Seal®

SchuF's sister company, Fetterolf Corporation, are inventors of **Ram-Seal®** and **Rod-Seal®** valves, both of which utilise patented principles to provide zero leakage and clog-free flow when open

Ram-Seal® valves feature a fully-integrated seat. Full valve sealing forces only compress the sealing ring when the ram/piston is in the fully closed position: Full vessel outlet bore flow is provided.

The **Ram-Seal®** drain valve is a free-flowing, full-opening valve design that offers bubble-tight Class VI sealing characteristics that ensure positive shut-off to process.

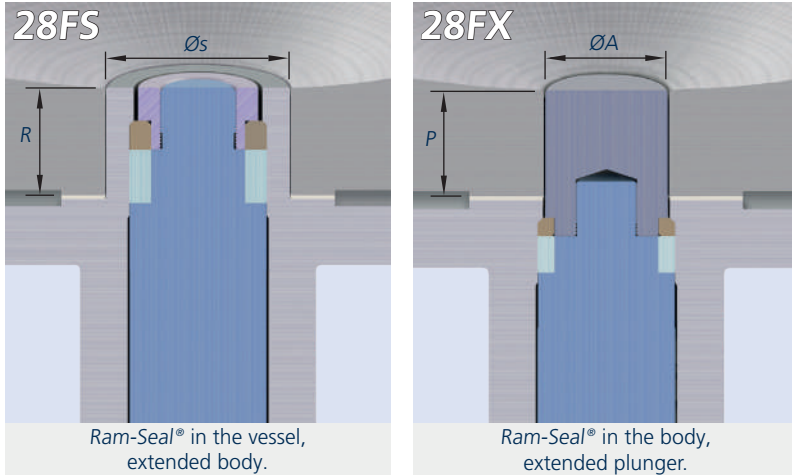

In laboratory tests Ram-Seal valves have exceeded all Class requirements and delivered positive shut-off over several hours of testing.

The design ensures: clog-free performance, flow in either direction, high Cv, no leaks, extended seal life, and diverse Low emissions.

Replaceable **M-Seal®** sealing rings provide metal-to-metal sealing standards for extreme conditions

The Fetterolf Ram-Seal® advantage

Stroking

The ram/piston strokes upwards as the valve closes: the sealing ring (in blue, right) is not in contact with the body wall as it travels, ensuring minimised wear during stroking. This ensures long seal life and reduced maintenance costs. The same minimised-wear performance applies as the valve strokes open.

Closure

When the ram/piston reaches the point of closure, the compression ring (in yellow, right) meets the body face. Actuator forces continue pushing the piston upwards, so the sealing ring is then squeezed outwards to provide the required high-quality seal against the internal body wall until the valve is opened once more.

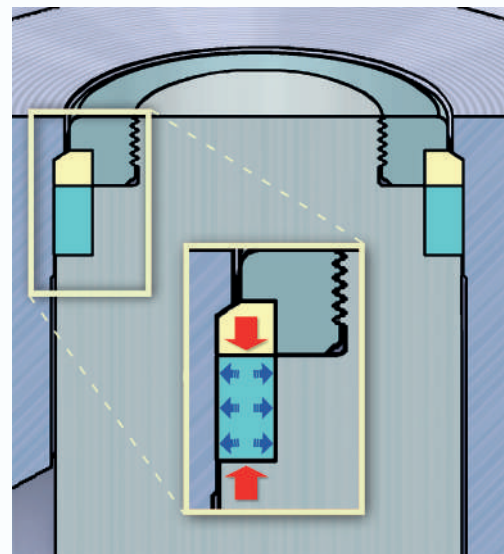
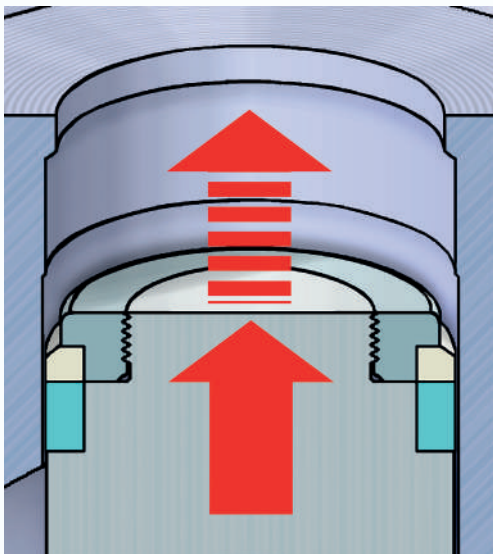

SchuF Fetterolf Ram/Piston Valves: Ram-Seal®

Type 28FS/FX Ram-Seal® Valve - Standard Materials of Construction

Compression Ring exerts force on Seal ring only in closed position

316 Stainless Steel Body, other materials as requested

Selection of Seal-to-atmosphere arrangements available

Manual actuator with non-rising handwheel. Full range of other actuation options available

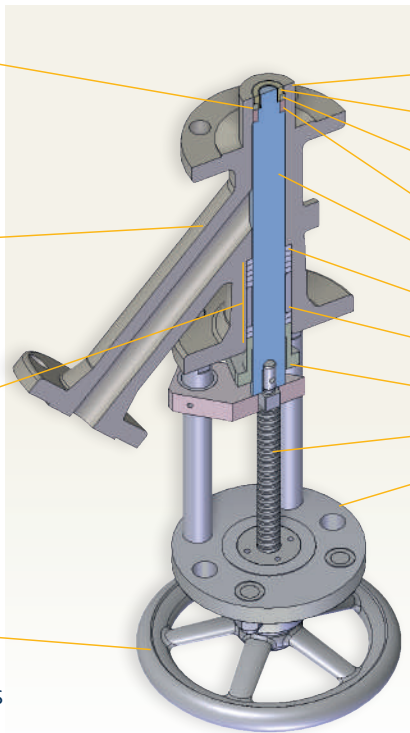

Item	Description	Material	Qty.
1	Body	Type 316 Stainless Steel	1
2	Plunger Head Nut	Type 316 Stainless Steel	1
3	Compression Ring	Type 316 Stainless Steel	1
4	Seal Ring	TFE (Standard)	1
5	Ram/Plunger	Type 316 Stainless Steel	1
6	Packing Ring	TFE/Kevlar (Standard)	6
7	Spacer	Type 316 Stainless Steel	1
8	Stuffing-Box Gland	Type 304 Stainless Steel	1
9	Stem	Type 416 Stainless Steel	1
10	Actuator	Zinc-coated Carbon Steel	1

Standard Ram-Seal® Valve Flange Sizes:

Valve Size, Imperial↓	ASME 150		ASME 300	
	Top/Inlet Flange	Branch Flange	Top/Inlet Flange	Branch Flange
1"	1", 1½", 2", 2½"	1"	1"	1"
1½"	1½", 2", 2½", 3"	1½"	1½"	1½"
2"	2", 2½", 3"	2"	2"	2"
3"	3", 4"	3"	3"	3"
4"	4"	4"	4"	4"
6"	6"	6"	6"	6"
8"	8"	8"	8"	8"
10"	10"	10"	10"	10"

Valve Size, Metric↓	PN16		PN40	
	Top/Inlet Flange	Branch Flange	Top/Inlet Flange	Branch Flange
DN25	DN25, DN40, DN50, DN65	DN25	DN25	DN25
DN40	DN40, DN50, DN65, DN80	DN40	DN40	DN40
DN50	DN50, DN65, DN80	DN50	DN50	DN50
DN80	DN80, DN100	DN80	DN80	DN80
DN100	DN100	DN100	DN100	DN100
DN150	DN150	DN150	DN150	DN150
DN200	DN200	DN200	DN200	DN200
DN250	DN250	DN250	DN250	DN250

Left: Ram-Seal® Valve with pneumatic linear actuator



Right: Ram-Seal® Valve with an electric motor



SchuF Fetterolf Ram/Piston Valves: Ram-Seal®

All dimensions in mm

Type 28FS/FX Ram-Seal® Valve Valve Standard Dimensions (Type NA non-rising handwheel)

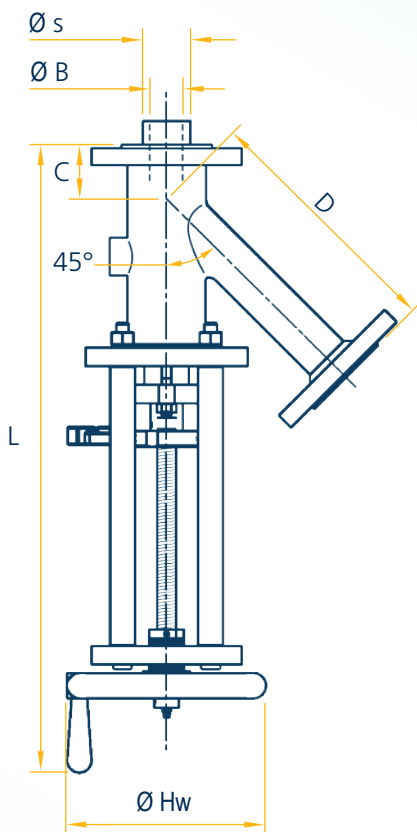

ASME 150 / PN16

Rating and Variable Valve Size ↓ →	Ø B (Port)	C	D	L	ØHw	Ø s (min.)
1"/DN25	24	57	209	518	160	33.4
1½"/DN40	30	65	262	597	225	40.7
2"/DN50	43	65	293	641	225	61.4
3"/DN80	65	79	334	743	225	89
4"/DN100	81	79	393	870	360	101.6
6"/DN150	130	87	471	1181	500	166.5
8"/DN200	181	104	528	1213	500	213
10"/DN250	235	177	723	1657	813	265

ASME 300 / PN25

Rating and Variable Valve Size ↓ →	Ø B (Port)	C	D	L	ØHw	Ø s (min.)
1"/DN25	24	57	209	521	160	35.7
1½"/DN40	30	65	262	600	225	44.1
2"/DN50	43	65	293	648	225	66.7
3"/DN80	65	79	334	749	225	94
4"/DN100	81	79	393	876	360	117

SchuF Fetterolf Ram/Piston Valves: Rod-Seal®

Rod-Seal® valves with their seatless design with automatic rodding on every stroke remove any areas where media can stick or accumulate

Rod-Seal® valves also feature a fully-integrated seat. 'Super Closure' provides extra-tight shut-off to both process and atmosphere at full closure. Full vessel outlet bore flow also provided.

The **Rod-Seal®** valve is designed and built to eliminate typical problems of conventional valves.

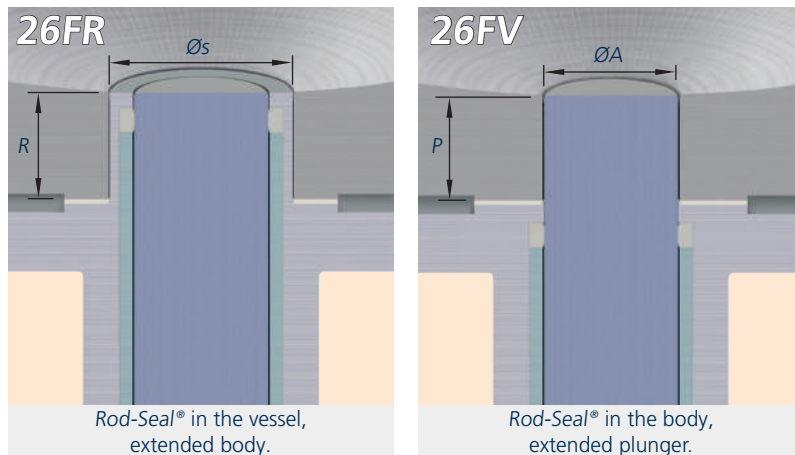

The seatless sealing principle plus "Super Closure" thrust-loading provides the basis for the Rod-Seal difference.

The valve has been proven in sampling, purging, or draining highly viscous media, polymers, abrasive slurries, and powders.

Rod-Seal® valves offer free-flow with no obstruction from stem within product stream, as well as a low pressure-drop, high-Cv 45° discharge pattern (60 or 90° branch angles are alternative options)

The Fetterolf Rod-Seal®, featuring 'Super-Closure'

Stroking

The sealing rings (in yellow, below) are not highly compressed while the ram/piston is stroking, ensuring reduced wear. The springs (red) maintain a minimum sealing force on the stuffing box (green) and packing rings (white). Note the location of the plunger drive bushing (orange), at the bottom of the image, while the valve is stroked open.

Closure

When the ram/piston reaches the point of closure, the plunger drive bushing (in orange, below) meets the stuffing box gland face, and provides **Super Closure**, a broad-band seal between the sealing rings (yellow) and surrounding body faces. There is also enhanced seal-to-atmosphere capability through the packing rings at this point.

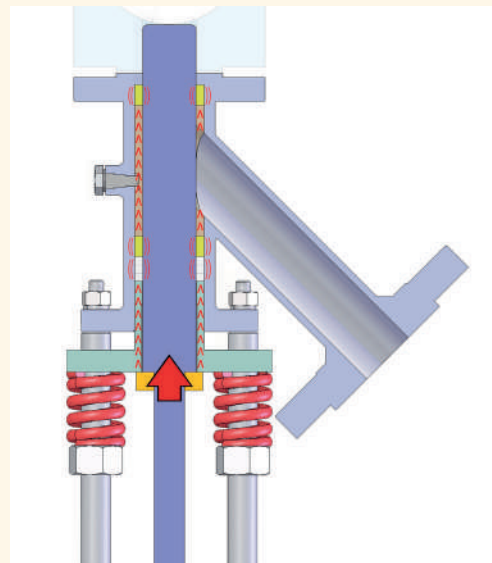
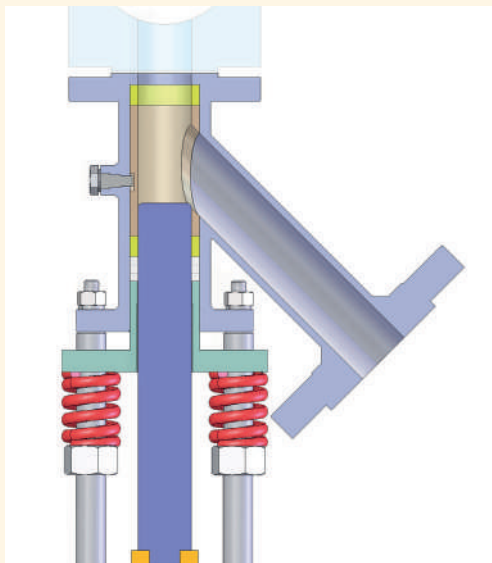

SchuF Fetterolf Ram/Piston Valves: Rod-Seal®

Type 26FR/FV Rod-Seal® Valve - Standard Materials of Construction

Maximum Sealing Force on Seal ring applied only in closed position

316 Stainless Steel Body, other materials as requested

Selection of Seal-to-atmosphere arrangements available

Manual actuator with non-rising handwheel. Full range of other actuation options available

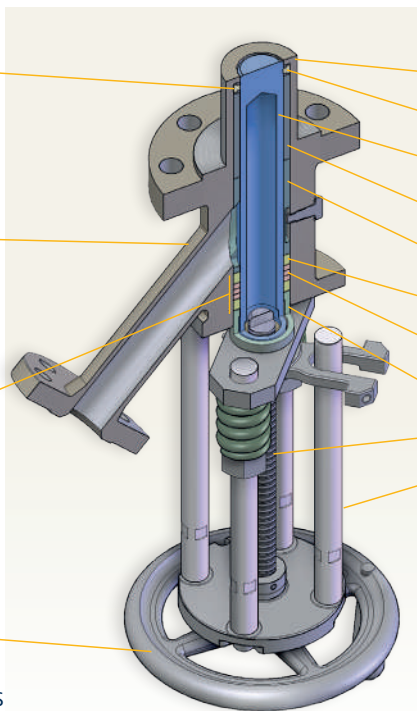

Item	Description	Material	Qty.
1	Body	Type 316 Stainless Steel	1
2	Sealing Ring	TFM/Glass	1
3	Ram/Plunger	Type 316 Stainless Steel	1
4	Guide Ring Extension	Type 316 Stainless Steel	1
5	Guide Ring	Type 316 Stainless Steel	1
6	Seal Ring	TFM	2
7	Packing Ring	TFE/Kevlar (Standard)	3
8	Stuffing-Box Gland	Type 304 Stainless Steel	1
9	Stem	Type 416 Stainless Steel	1
10	Actuator	Zinc-coated Carbon Steel	1

Standard Rod-Seal® Valve Flange Sizes:

Valve Size, Imperial	ASME 150		ASME 300	
	Top/Inlet Flange	Branch Flange	Top/Inlet Flange	Branch Flange
1"	1", 1½", 2", 2½"	1"	1"	1"
1½"	1½", 2", 2½", 3"	1½"	1½"	1½"
2"	2", 2½", 3"	2"	2"	2"
3"	3", 4"	3"	3"	3"
4"	4"	4"	4"	4"
6"	6"	6"	6"	6"
8"	8"	8"	8"	8"
10"	10"	10"	10"	10"

Valve Size, Metric	PN16		PN40	
	Top/Inlet Flange	Branch Flange	Top/Inlet Flange	Branch Flange
DN25	DN25, DN40, DN50, DN65	DN25	DN25	DN25
DN40	DN40, DN50, DN65, DN80	DN40	DN40	DN40
DN50	DN50, DN65, DN80	DN50	DN50	DN50
DN80	DN80, DN100	DN80	DN80	DN80
DN100	DN100	DN100	DN100	DN100
DN150	DN150	DN150	DN150	DN150
DN200	DN200	DN200	DN200	DN200
DN250	DN250	DN250	DN250	DN250

Left: Rod-Seal® Valve with electric actuator



Right: Rod-Seal® Valve with linear pneumatic actuator



SchuF Fetterolf Ram/Piston Valves: Rod-Seal®

Type 26FR/FV Rod-Seal® Valve Standard Dimensions (Type NA non-rising handwheel)

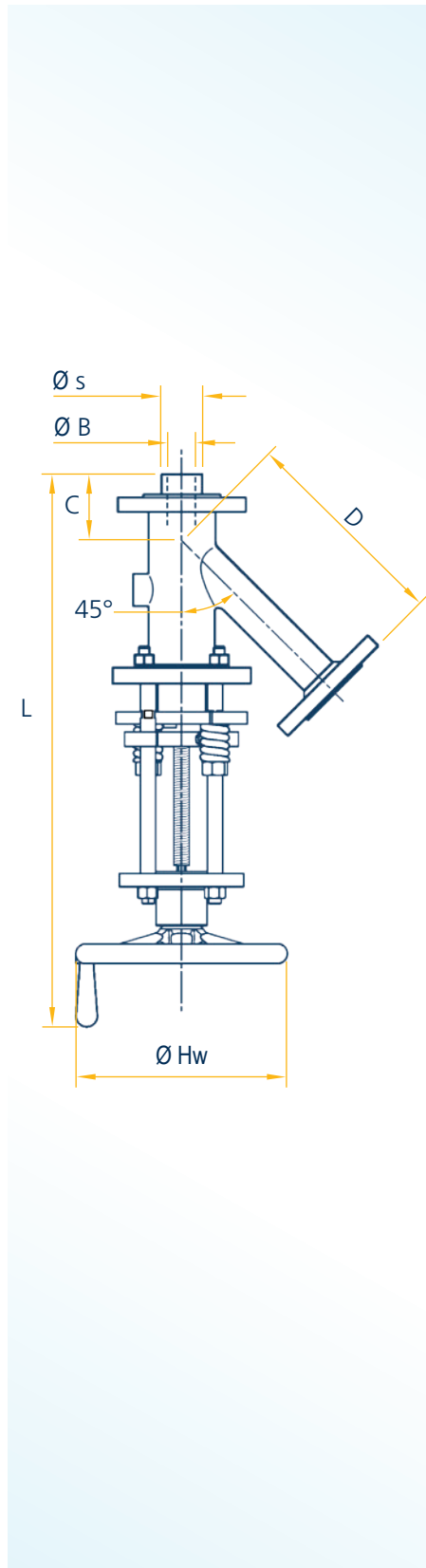

ASME 150 / PN16

Rating and Variable Valve Size → ↓	Ø B (Port)	C	D	L	ØHw	Ø s (min.)
1"/DN25	27	57	209	594	160	47
1½"/DN40	42	65	262	639	225	64
2"/DN50	52	65	293	728	225	78
3"/DN80	82	79	390	949	225	109
4"/DN100	102	98	479	1005	360	134
6"/DN150	152	117	537	1277	210	185
8"/DN200	202	124	542	1392	210	237
10"/DN250	252	118	601	1769	400	289
12"/DN300	302	165	798	2014	400	340

ASME 300 / PN25

Rating and Variable Valve Size → ↓	Ø B (Port)	C	D	L	ØHw	Ø s (min.)
1"/DN25	27	57	209	594	160	48
1½"/DN40	42	65	262	634	225	65
2"/DN50	52	65	293	733	225	80
3"/DN80	82	79	334	934	225	112
4"/DN100	102	98	393	1005	360	137
6"/DN150	152	117	471	1295	210	190
8"/DN200	202	124	528	1587	400	245
10"/DN250	252	118	723	1759	400	300
12"/DN300	302	165	723	2014	400	355

SchuF Sampling Valve Range

SchuF offers a large range of sampling valve solutions. Standard Model 32 sampling valves are available from stock for fast deliveries and custom-built solutions are also available. SchuF Sampling Valves are designed to simplify the extraction of samples from or the injection into tanks, reactors or pipelines and allow for long, trouble-free service. They are non-clogging and dead-space free.

The SchuF Model 32 Series is available in standard sizes from stock for fast delivery:

Model 32FR “ROD SEAL®”:

The “ROD SEAL®” design embodies the self-cleaning, seatless valve principle. Only SchuF Fetterolf offers the feature of “Super-Closure”, utilizing spring-loaded components. Ideal for extended plungers for crust-breaking- see page 31.

Model 32PG (Metal Seal):

This robust, metal seated sampling valve is ideal for high temperature applications and can be manufactured in certified, FIRE-SAFE versions. Immediate flow is achieved as soon as the crank handle is turned. The 32PG is also ideal for injecting media into piping or vessels, since there are no soft sealing rings exposed to the flow. - see page 28.

Model 32FG “RAM SEAL®”:

The patented “RAM SEAL®” design features replaceable seal rings for ease of maintenance. The combination of a metal compression ring and a soft PTFE seal ring allows the delivery of incredibly low leakage rates in a variety of services (gas and liquid) over long periods of time- see page 32.

Model 32PT

The 32PT is a metal-seated, disc-type sampling valve, The disc opens into the process medium- see page 29.



Key Features

- All Model 32 valves are rated to ASME 600.
- Crank handle manual operators are easy to use.
- The outlet branch is at 60 degrees.
- All valves have Leakage Class VI shut-off (100% tested).
- Cast yokes and bodies are of a robust design.

Materials of Construction:

All wetted parts and bodies can be manufactured in a variety of materials, including:

- 316 stainless steel (standard)
- Titanium
- Nickel Alloys
- Alloy 20
- Monel
- Others available as per customer specifications.

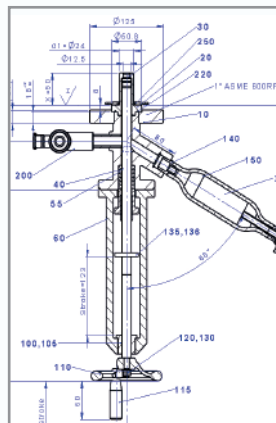

Actuation:

- Manual (Crank Handle, Handwheel or Bevel Gears)
- Deadman’s Handle
- Pneumatic
- Others available

Options:

- See page 9 for further info on Sample Bottles, Integral Heating Jackets, Flushing Ports, Extended Rams/Pistons and Bodies, and Alternative Inlet Connections such as T-Pieces, Half-Couplings, etc.

Type 32 Connection Options

Extended Rams/Pistons and Extended Bodies plus alternative valve connections

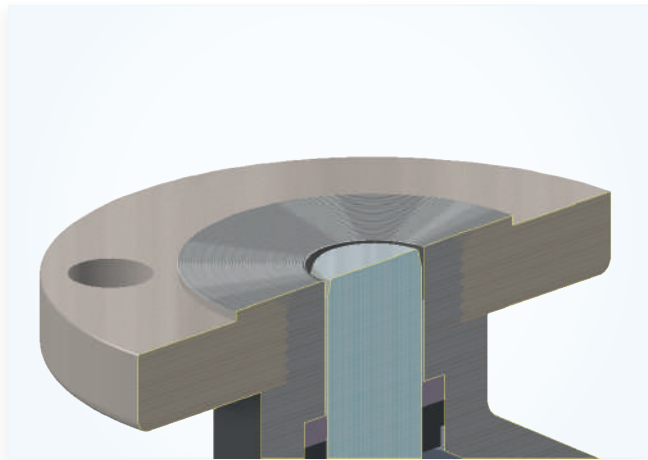

Flanged Connection

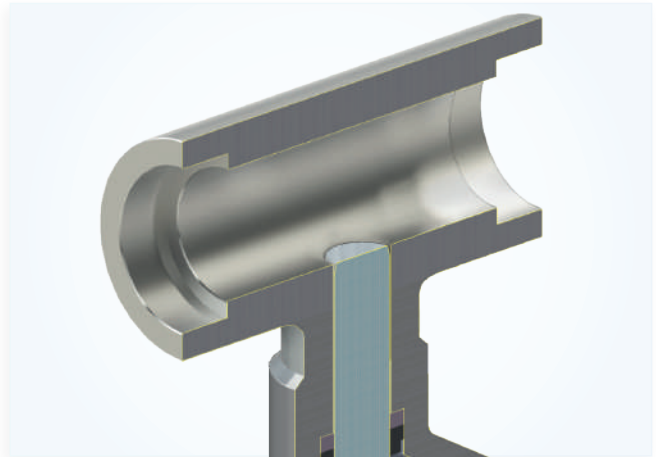

T-Piece

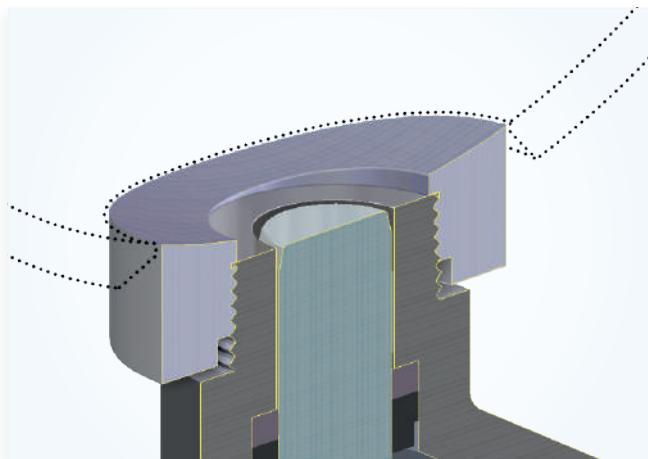

Contoured Half-Coupling

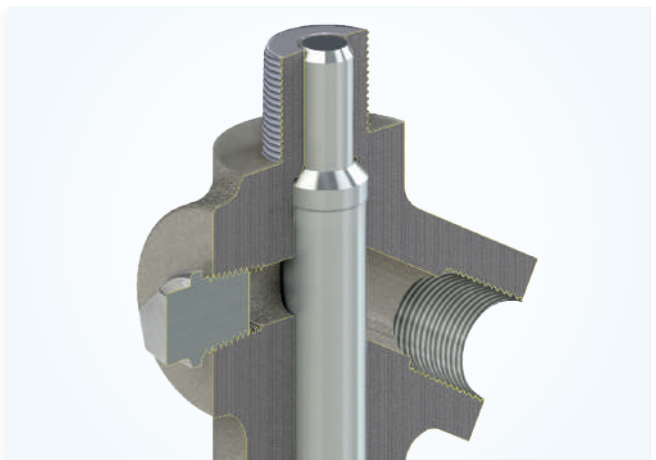

Additional Purge Connection



Left: Type 32PG

Model 32PG Standard Dimensions

Model 32PG Valve with Metal-Seated Ram/Piston

Super-low Class VI shut-off leakage rate, low-maintenance, full flow

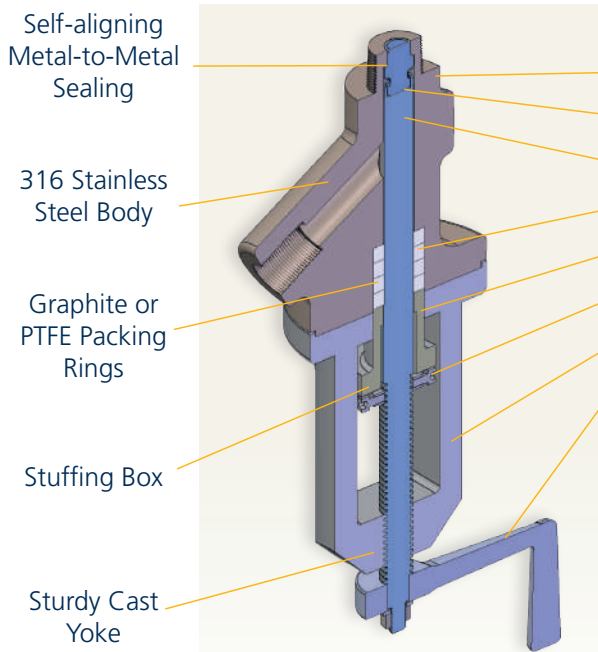

Item	Description	Material	Qty.
1	Body	ASTM GR.CF-8M/1.4408	1
2	Ram/Piston	SS316/1.4401	1
3	Spindle	SS416/1.44005	1
4	Packing Ring	PTFE/Graphite	4
5	Stuffing-Box Gland	ASTM GR.CF-8M/1.4408	1
6	Indicator	SS303/1.4305	1
7	Yoke	SS303/1.4305	1
8	Crank Handle	ASTM GR.CF-8/1.4308	1

- Max. Temperature: PTFE Packing Rings 260°C, Graphite Packing Rings 550°C.
- Pressure rating: Valves rated to ASME 600.



Certification according to API 607:2010 & ISO 10497: 2010

Model 32PG Standard Dimensions

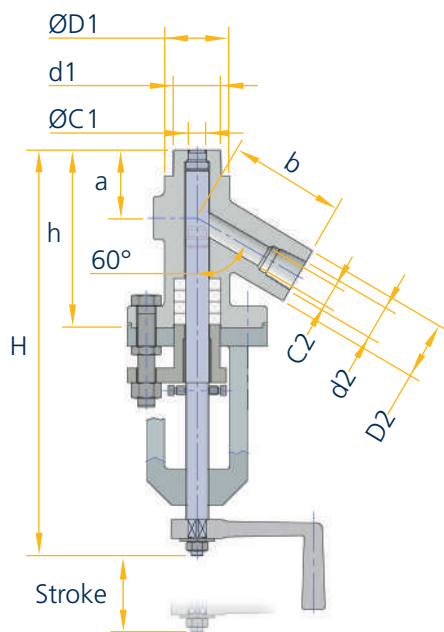

Size →	½"	¾"	¾"	1"	1"	1½"
↓ Variable	½"	¾"	¾"	½"	¾"	1"
ØD1	45	45	45	45	45	60
ØD2	40	40	40	40	40	45
d1 [NPT]	½"	¾"	¾"	1"	1"	1½"
d2 [NPT]	½"	½"	¾"	½"	¾"	1"
ØC1	12.5	12.5	12.5	12.5	12.5	25
ØC2	15	15	15	15	15	25
a	47	47	47	47	47	47
b	80	80	80	80	80	90
h	123	123	123	123	123	140
H	295	295	295	295	295	310
Stroke	55	55	55	55	55	55

Model 32PT Standard Dimensions

Model 32PT Metal-Seated Disc

The 32PT is a metal-seated, disc-type sampling valve. When the valve is opened, the disc rises into the vessel or pipe. By doing so, it breaks any crust that can impede the flow of a sample. The 32PT opens to full flow very quickly thanks to its short stroke.

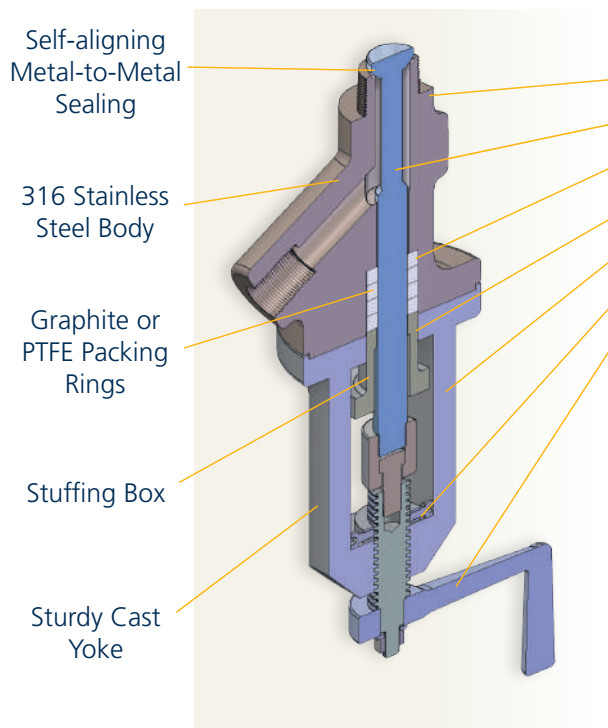

Item	Description	Material	Qty.
1	Body	ASTM GR.CF-8M/1.4408	1
2	Disc with Spindle	SS316/1.4401	1
3	Packing Ring	PTFE/Graphite	4
4	Stuffing-Box Gland	ASTM GR.CF-8M/1.4408	1
5	Yoke	SS303/1.4305	1
6	Indicator	SS303/1.4305	1
7	Crank Handle	ASTM GR.CF-8/1.4308	1

- Max. Temperature: PTFE Packing Rings 260°C, Graphite Packing Rings 550°C.
- Pressure rating: Valves rated to ASME 600.



Certification according to API 607:2010 & ISO 10497: 2010

Model 32PT Standard Dimensions

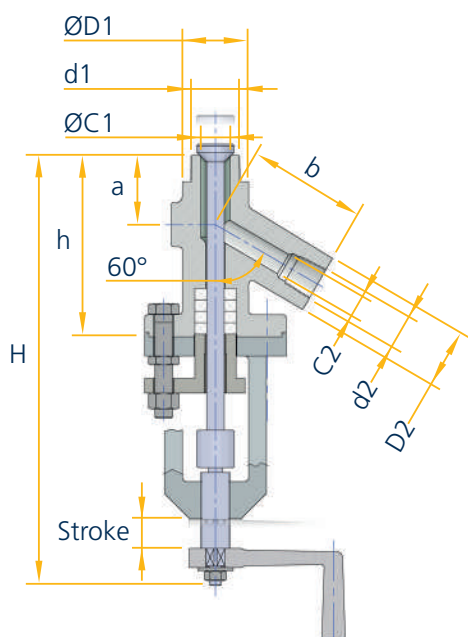

Size →	½"	¾"	¾"	1"	1"	1½"
↓ Variable	x ½"	x ½"	x ¾"	x ½"	x ¾"	x 1"
ØD1	45	45	45	45	45	60
ØD2	40	40	40	40	40	45
d1 [NPT]	½"	¾"	¾"	1"	1"	1½"
d2 [NPT]	½"	½"	¾"	½"	¾"	1"
ØC1	12.5	12.5	12.5	12.5	12.5	25
ØC2	15	15	15	15	15	25
a	47	47	47	47	47	47
b	80	80	80	80	80	90
h	123	123	123	123	123	140
H	295	295	295	295	295	310
Stroke	55	55	55	55	55	55

Type 32 Ram/Piston and Seat Options

Extended Ram/Piston and Extended Bodies plus alternative valve connections

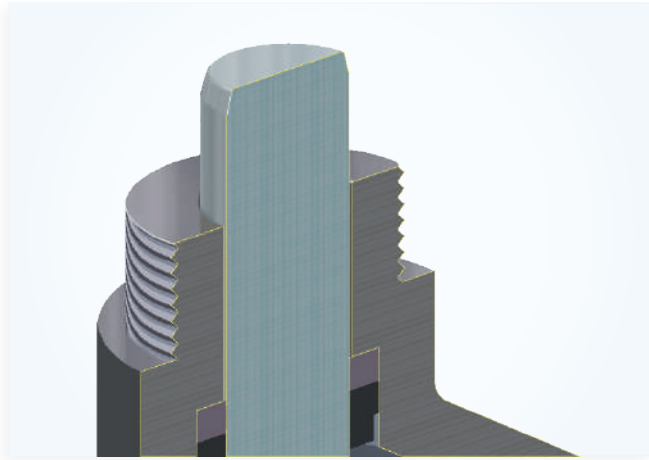

Ram/Piston Extension

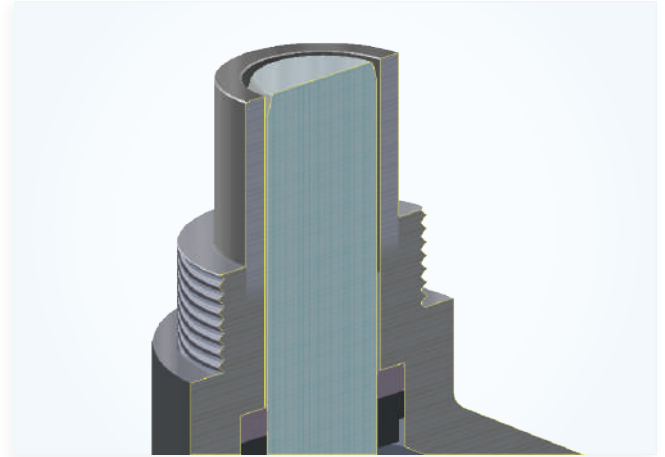

Fixed Seat

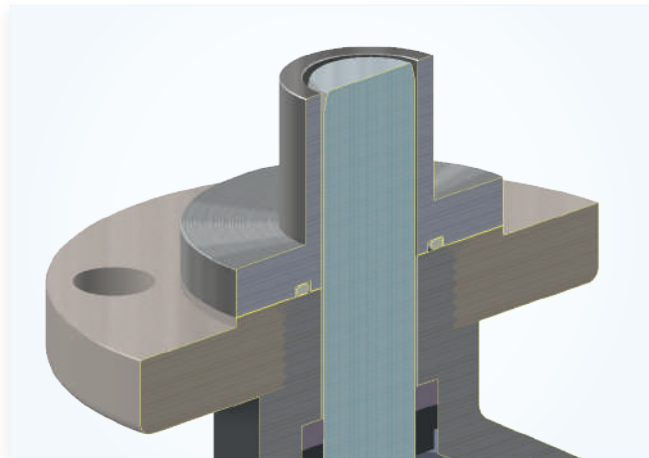

Extended Body/Seat

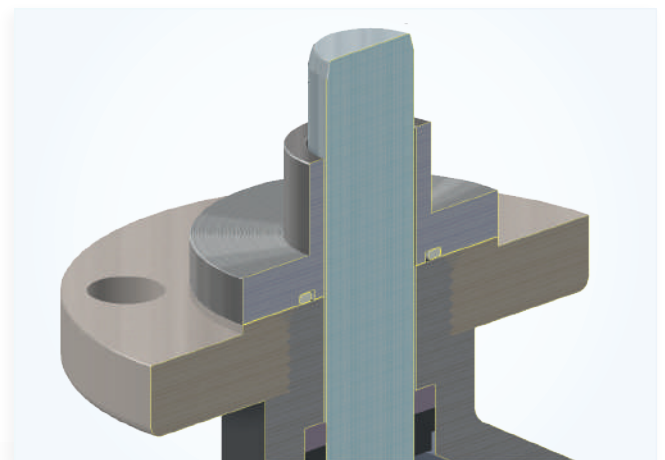

Extended Body/Seat with extra Ram/Piston Extension



Left: Type 32FR

Model 32FR Standard Dimensions

Model 32FR 'Rod Seal'

Self-cleaning and seatless, the model 32FR features 'Super Closure' using spring-loaded components, which allows high-level sealing while maximising maintenance intervals

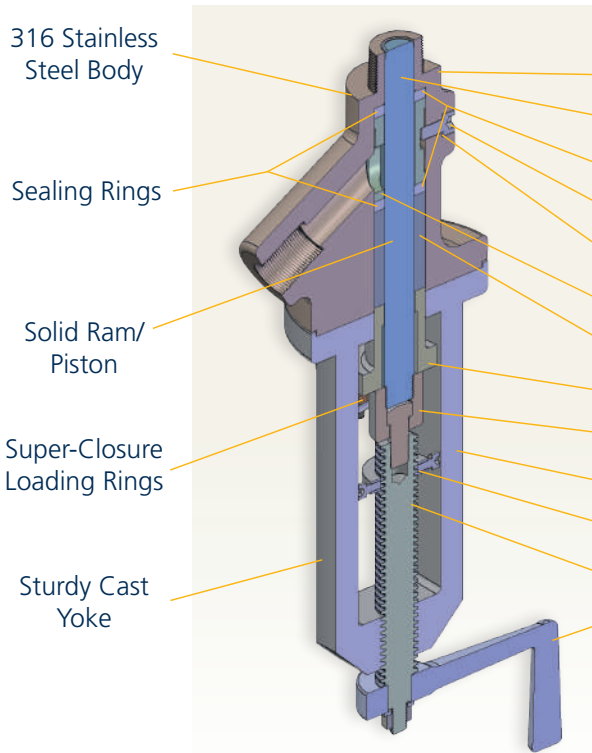

Item	Description	Material	Qty.
1	Body	ASTM GR.CF-8M/1.4408	1
2	Ram/Piston	SS316/1.4401	1
3	Sealing Ring	PTFE/GLASS 25%	2
4	Socket-Head Cap Screw	A2-70	1
5	Gasket	Fluoroloy K	1
6	Pressure Sleeve	SS316/1.4401	1
7	Guide Bush	SS316/1.4401	1
8	Stuffing-Box Gland	ASTM GR.CF-8M/1.4408	1
9	Connecting Nut	SS416/1.44005	1
10	Yoke	SS303/1.4305	1
11	Indicator	SS303/1.4305	1
12	Spindle	SS416/1.44005	1
13	Crank Handle	ASTM GR.CF-8/1.4308	1

- Max. Temperature: PTFE Sealing Rings 200°C, Blue Guard Sealing Rings 370°C.
- Pressure rating: Valves rated to ASME 600.

Model 32FR Standard Dimensions

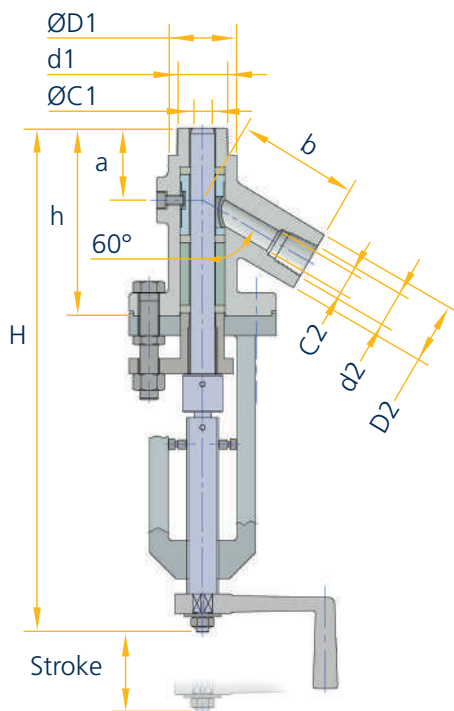

Size →	½"	¾"	¾"	1"	1"	1½"
↓ Variable	x ½"	x ½"	x ¾"	x ½"	x ¾"	x 1"
ØD1	45	45	45	45	45	60
ØD2	40	40	40	40	40	45
d1 [NPT]	½"	¾"	¾"	1"	1"	1½"
d2 [NPT]	½"	½"	¾"	½"	¾"	1"
ØC1	13	16	16	16	16	25
ØC2	15	15	15	15	15	25
a	47	47	47	47	47	47
b	80	80	80	80	80	90
h	123	123	123	123	123	140
H	345	345	345	345	345	360
Stroke	60	60	60	60	60	65

Model 32FG Standard Dimensions

Model 32FG 'Ram Seal'

The patented "RAM SEAL®" design features replaceable seal rings for ease of maintenance. The combination of a metal compression ring and a soft PTFE seal ring allows the valve to deliver incredibly low leakage rates in a variety of services (gas and liquid) over a long period of time

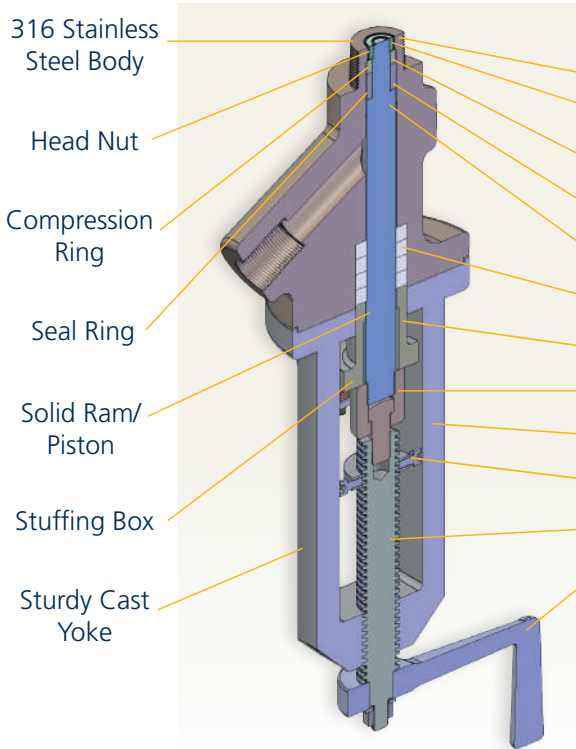

Item	Description	Material	Qty.
1	Body	ASTM GR.CF-8M/1.4408	1
2	Ram/Piston Head Nut	SS316/1.4401	1
3	Compression Ring	PTFE/GLASS 25%	2
4	Sealing Ring	A2-70	1
5	Ram/Piston	SS316/1.4401	1
6	Packing Ring	SS316/1.4401	1
7	Stuffing-Box Gland	ASTM GR.CF-8M/1.4408	1
8	Connecting Nut	SS416/1.44005	1
9	Yoke	SS303/1.4305	1
10	Indicator	SS303/1.4305	1
11	Spindle	SS416/1.44005	1
12	Crank Handle	ASTM GR.CF-8/1.4308	2

- Max. Temperature: PTFE Sealing Ring 260°C
- Pressure rating: Valves rated to ASME 600.

Model 32FG Standard Dimensions

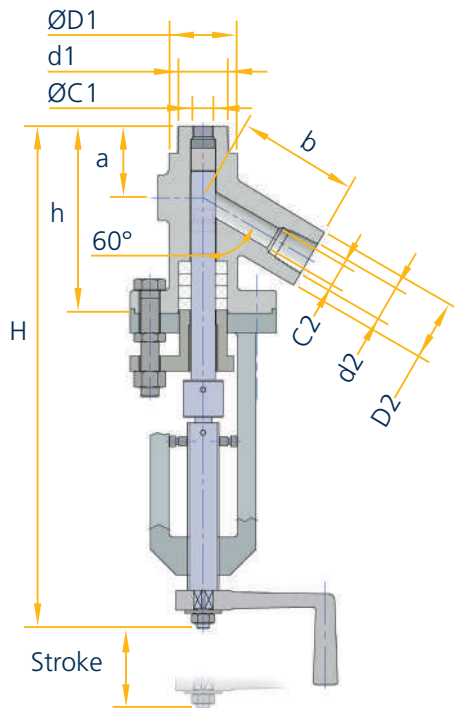

Size →	1/2"	3/4"	3/4"	1"	1"	1 1/2"
↓ Variable	x 1/2"	x 1/2"	x 3/4"	x 1/2"	x 3/4"	x 1"
$\varnothing D1$	45	45	45	45	45	60
$\varnothing D2$	40	40	40	40	40	45
$d1$ [NPT]	1/2"	3/4"	3/4"	1"	1"	1 1/2"
$d2$ [NPT]	1/2"	1/2"	3/4"	1/2"	3/4"	1"
$\varnothing C1$	13	16	16	16	16	25
$\varnothing C2$	15	15	15	15	15	25
a	47	47	47	47	47	47
b	80	80	80	80	80	90
h	123	123	123	123	123	140
H	345	345	345	345	345	360
Stroke	60	60	60	60	60	65

Model 31PF Standard Dimensions

Model 31PF 'Integral Flange'

These valves are built with an integral metal flange welded to the valve body. The complete assembly is installed in the product line (can be bolted, clamped or welded). The valve seals flush with the inner diameter (ID) of the insert which has the same ID as the product line, guaranteeing a dead-space-free arrangement.

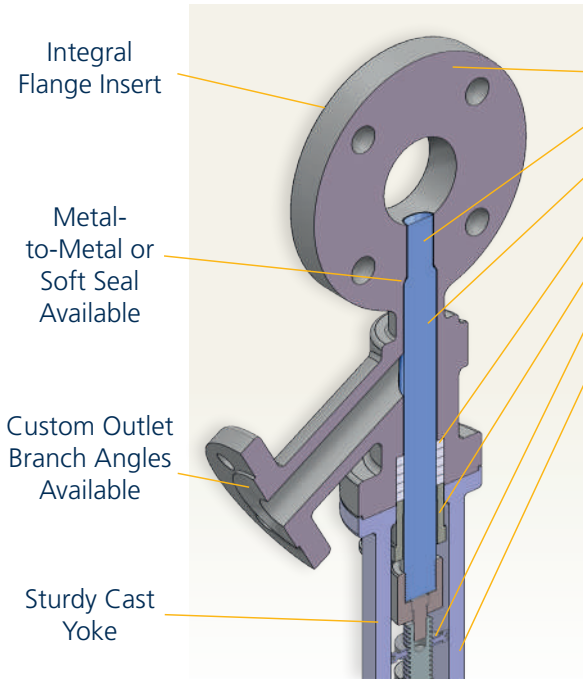

Item	Description	Material	Qty.
1	Body/Integral Flange	ASTM GR.CF-8M/1.4408	1
2	Disc	SS316/1.4401	1
3	Spindle	SS416/1.44005	1
4	Packing Ring	PTFE/Graphite	4
5	Stuffing-Box Gland	ASTM GR.CF-8M/1.4408	1
6	Indicator	SS303/1.4305	1
7	Yoke	SS303/1.4305	1
8	Crank Handle	ASTM GR.CF-8/1.4308	1

- Max. Temperature: PTFE Packing Rings 260°C, Graphite Packing Rings 550°C.
- Pressure rating: Valves rated to ASME 600.

The flanged insert-piece can include bolt-holes or, as below, simply match the raised face/gasket diameter

Model 31PF Standard Dimensions

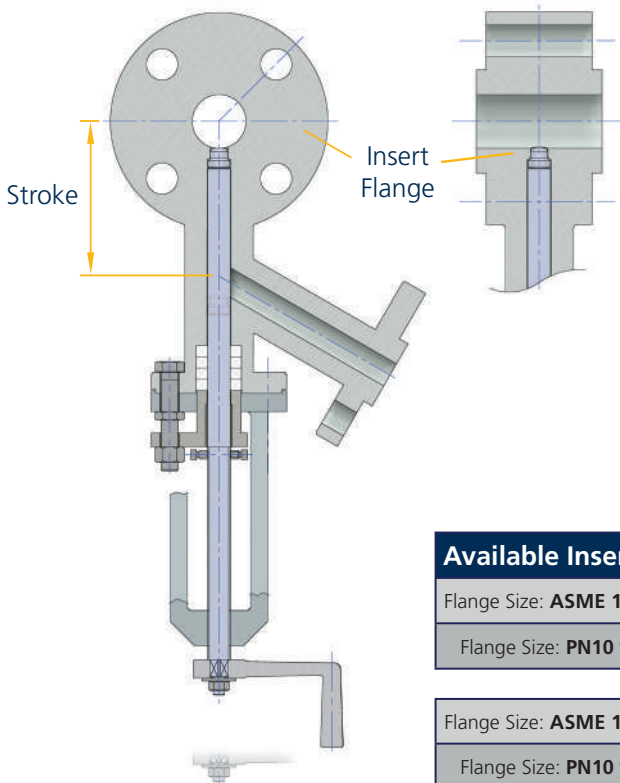

Right: Full heating/Cooling Jackets also available

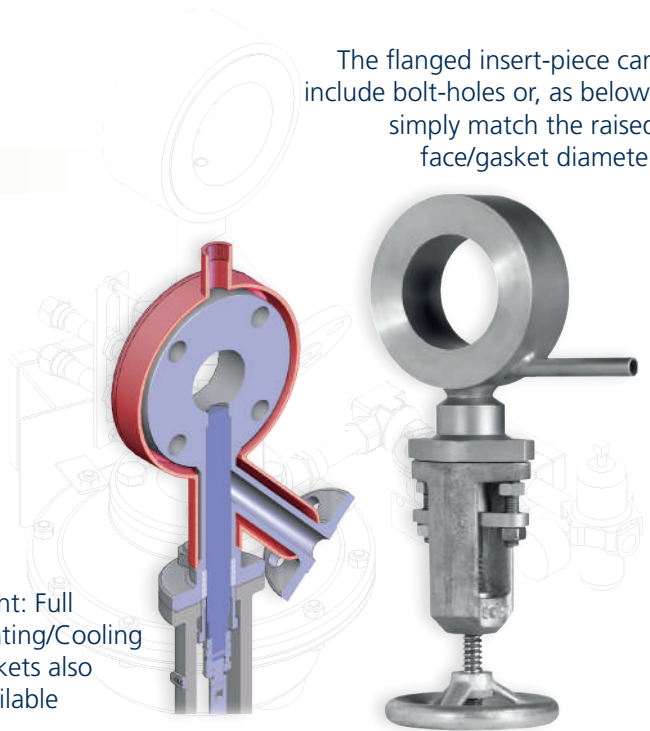

Available Insert Flange Sizes:

Flange Size: ASME 150 to 600	½"	¾"	1"	1¼"	1½"	2"	2½"	3"
Flange Size: PN10 to PN63	DN10	DN15	DN20	DN25	DN32	DN40	DN50	DN65

Flange Size: ASME 150 to 600	3½"	4"	5"	6"	8"	10"	12"
Flange Size: PN10 to PN63	DN80	DN100	DN125	DN150	DN200	DN250	DN300

Models 30P and 30T - Custom Innovation

All Model 30 valves are custom-built assemblies. Options include a wide variety of metallurgies, actuators, pressure ratings from full vacuum to ASME 2500/PN 400, hardened sealing surfaces and replaceable seats.

Model 30P 'Core Pipe Assembly'

Model 30P valves (see examples, right) are also known as core pipe assemblies. They allow the user to take a sample under high temperature and pressure.

The valve is welded to a spool-piece which is a short piece of the process pipe. The valve assembly is welded directly into the process piping. In polymer applications, the 30P is usually fully jacketed.

The spool piece connections can be provided with alternative connections. The 30P can also be used to drain a line in a shut-down situation, to flush or purge it, or as an injection valve



Model 30T - Tangential Sampling With Contoured Ram/Piston

Another SchuF innovation, the 30T, allows the valve to be installed horizontally. This enables the gravity-driven sample drop to be carried out without the operator having to activate the valve while located under the pipe – a potentially dangerous situation should hot polymer splash or spill while the sample is being taken.

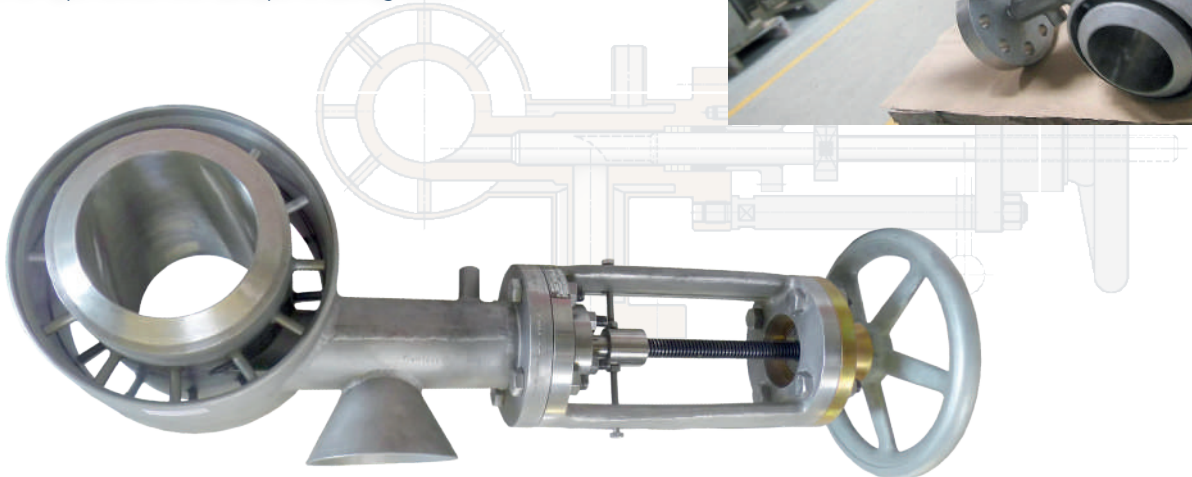

Sample Valve Custom Options

SchuF sample valves can be supplied with a number of different options and arrangements to suit any customer system or process requirements. All wetted parts and bodies can be manufactured in a variety of materials, including 316 stainless steel (standard), Titanium, Nickel Alloys, Alloy 20, Monel, with others available. SchuF will also fabricate to your specifications- please contact SchuF with any inquiries.

Jacketing

All SchuF sampling valves can be jacketed. Jackets are welded in place and can cover the entire valve body fully, preventing cold spots when the jacket is for heating purposes or maximising cooling when used for heat extraction.

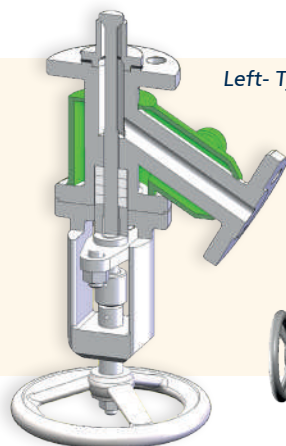

Left- Type 32PT with jacketed body

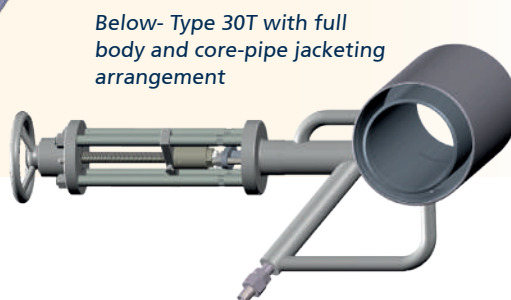

Below- Type 30T with full body and core-pipe jacketing arrangement

Sample Containers, Fixed-Volume Sampling

All SchuF sampling valves can be supplied with sample bottles of any size and type required- e.g. glass, or high-temperature metal containers. The bottle connection can allow venting as required. In this example, right, we see an isolated fixed-volume cooling or heating chamber which allows depressurised discharging into a container

Right: Type 32PG with vented PTFE coupling and glass bottle

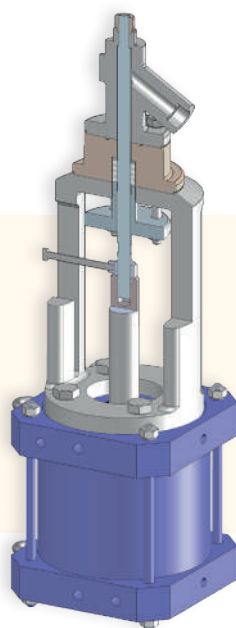

Left: Type 32PG valve with double-acting pneumatic actuator

Pneumatic Piston Actuator

Actuation of sample valves can be delivered with double-acting or spring-returned pneumatic actuators. More complex systems utilising control and instrumentation accessories are further possible options.

Sample Valve Custom Options

Sampling Systems

SchuF offer complete sampling systems which can include specific combinations of customised features in a single self-contained assembly. Such systems can offer increased safety, accuracy, speed and efficiency, particularly in challenging conditions.

Below: Type 32PG sampling valve with isolation valve, detachable stainless steel container and mechanical float device/indicator for accurate and safe fixed-volume sampling

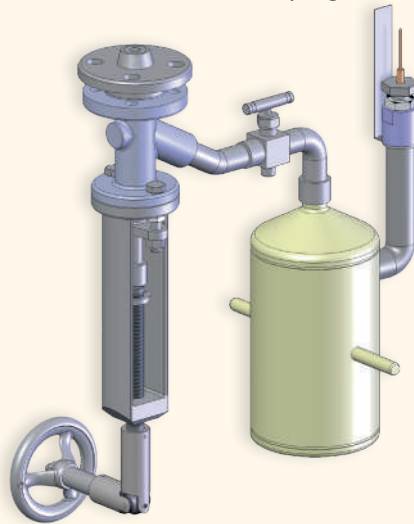

Right: Type 30PH jacketed sample valve, designed for pipe-sampling or injection duties

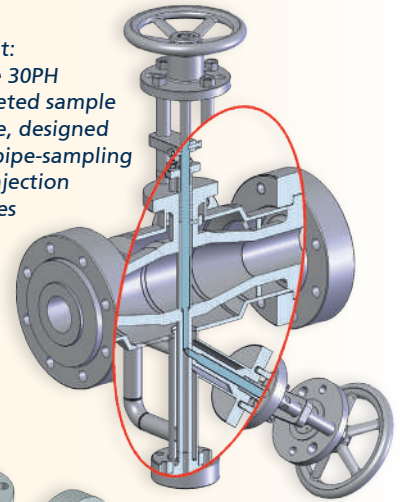

Right: Type 30TH jacketed sample valve for fixed-volume pipe-sampling

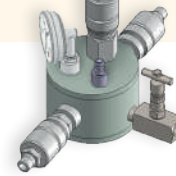
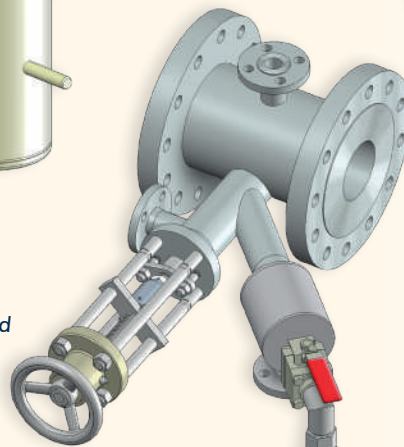

Enclosures and Lethal Service

SchuF can supply sampling systems and enclosures for critical applications and lethal service. The type 32PH sample valve has a metal bellows seal to atmosphere with an emergency stuffing-box which prevents leakage through the gland should the bellows break. A further option available is Leak Detection inside the gland.

Right: This Type 32PH sample valve utilises metal bellows sealing to atmosphere and can also accommodate internal leak detection

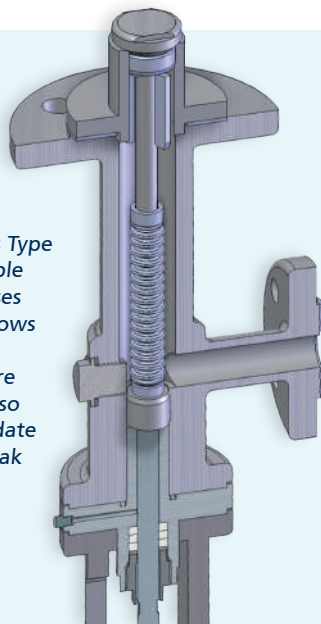

Right: SchuF can supply all types of sample valve enclosures, from basic to complex

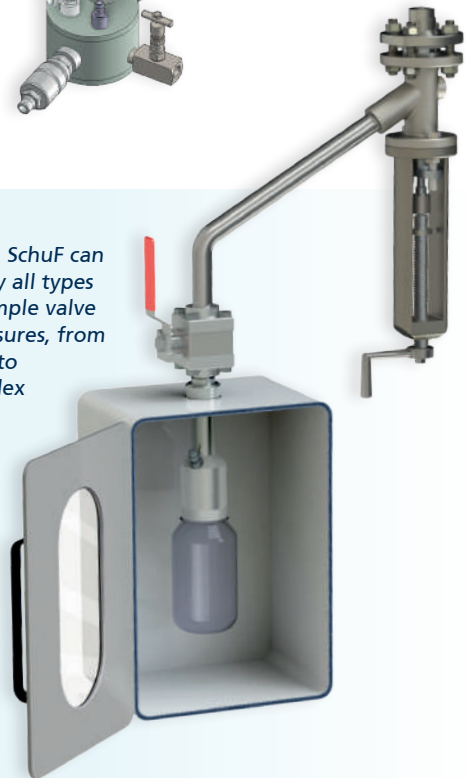

Sample Valve Custom Options

Added Innovation

This is an example of an already specialised Type 32FS sampling valve gaining additional functionality through innovative design. This valve is entirely removable without having to shut down the whole process unit- while the valve itself remains closed and self-contained.

The ram/piston strokes through the ball valve during normal sampling activities. When necessary, the ram/piston is retracted to an intermediate position and the dedicated ball valve is closed to isolate the system, allowing valve removal.

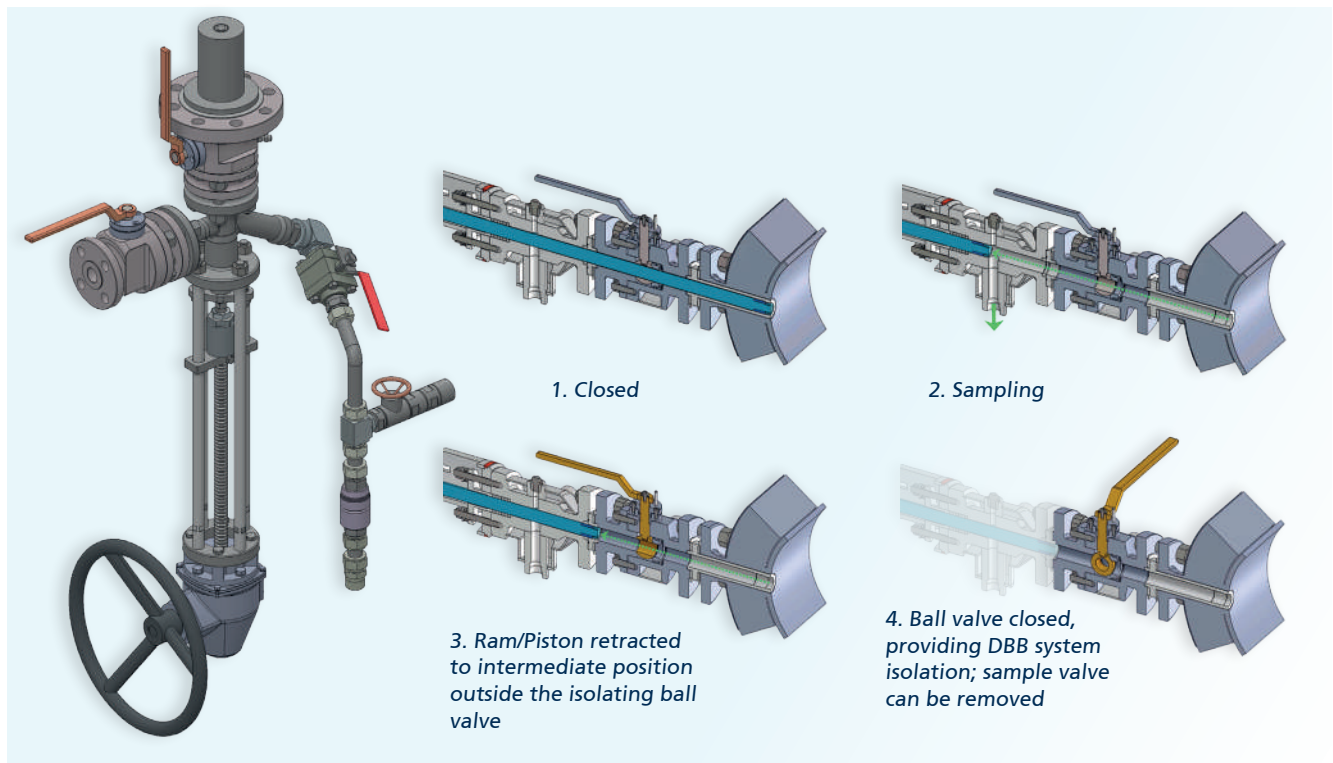
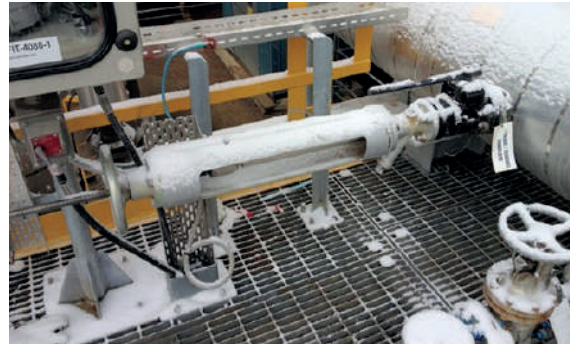

Deadman's Handle

Manual actuation can be via a standard handwheel, crank-handle or dead-man's handle.

A dead-man's handle provides a spring-returned lever action which ensures very fast and automatic closure upon release.

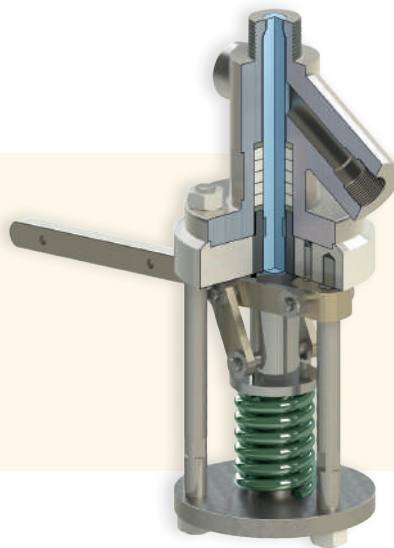

Left: Type 32PG sample valve featuring a dead-man's handle manual actuator

SchuF Valve Enquiry Sheet

SchuF		CUSTOMER APPLICATION DATA									
		sales@schuf.com			www.schuf.com		Date:				
Customer					Purchase Order No						
Customer Enq. Ref.					Item Number						
Quote Reference					Quantity						
Project Title					Customer Tag						
1	PROCESS DATA	Fluid			Critical Pressure			Shut-off Pressure			
			Units	Min	Norm	Max	Other				
2		Inlet State									
3		Flow Rate Mass									
4		Flow Rate Volume									
5		Inlet Pressure									
6		Outlet Pressure									
7		Inlet Temperature									
8		Molecular Mass									
9		Specific Heat Ratio									
10		Compressibility									
11		Specific Gravity									
12		Vapour Pressure									
13		Viscosity									
14	SPL @ 1m										
15	PIPE	Inlet Pipe Size / Sch					43	Actuator Type			
16		Outlet Pipe Size / Sch						44	Actuator Model / Stroke	/	
17		Insulation						45	Size / Spring	/	
18		Design Pressure						46	Fail Action		
19		Design Temp Min/Max.						47	System Air / Set Press.	/	
20	BODY	Valve Type						48	Actuator Orientation		
21		Size / Class						49	Handwheel		
22		Body Type						50	Volume Tank		
23		Body Material						51	Tubing		
24		End Connections						52	Fittings		
25		End Finish						53	Stroking Time		
26	Body F/F Dims						54	Positioner Model			
27	BONNET	Bonnet Type						55	Comms Protocol		
28		Bonnet Material						56	Control Signal		
29		Bonnet Bolting						57	Switch Type		
30		Gasket Material						58	Filter Regulator		
31		Gland Packing						59	Boosters		
32		Bellows Material						60	Solenoid		
33	TRIM	Trim Size / Type						61	Lockup Valves		
34		Cv / Characteristic						62	Relief Valve		
35		Balancing						63	Other Accessories		
36		Flow Direction						64	Other Accessories		
37		Plug/Seat/Cage Matl.						65	TEST	Design and Testing: Seat Leakage, Hydrostatic, Functional Test	
38		Seating Type						66			
39	Seat Leakage						67				
40	CERT	PED						68	Paint Finish	Standard	<input type="checkbox"/>
41		NACE						69	Mat. Cert Body / Bonnet		/
42		ATEX						70	Drawing Outl / GA / Hkp	No / No / No	<input type="checkbox"/>
71	NOTES								Rev.	Date	Desc.
72											
73											
74											
75											
76											
77											
78											
79											
80											

Product Portfolio Overview

The SchuF Group has delivered over one million valves during its 100-year history, to a wide variety of industries in over 50 countries worldwide. With headquarters near Frankfurt in Germany, the company has additional design and manufacturing centres in Italy, India, Ireland, UK and the

USA. SchuF has sales and agent offices servicing almost every country in the world. SchuF manufacture valve products that control, isolate, divert, and sample liquids, gases, powders, and slurries. Our product range of engineered, customised valves includes:

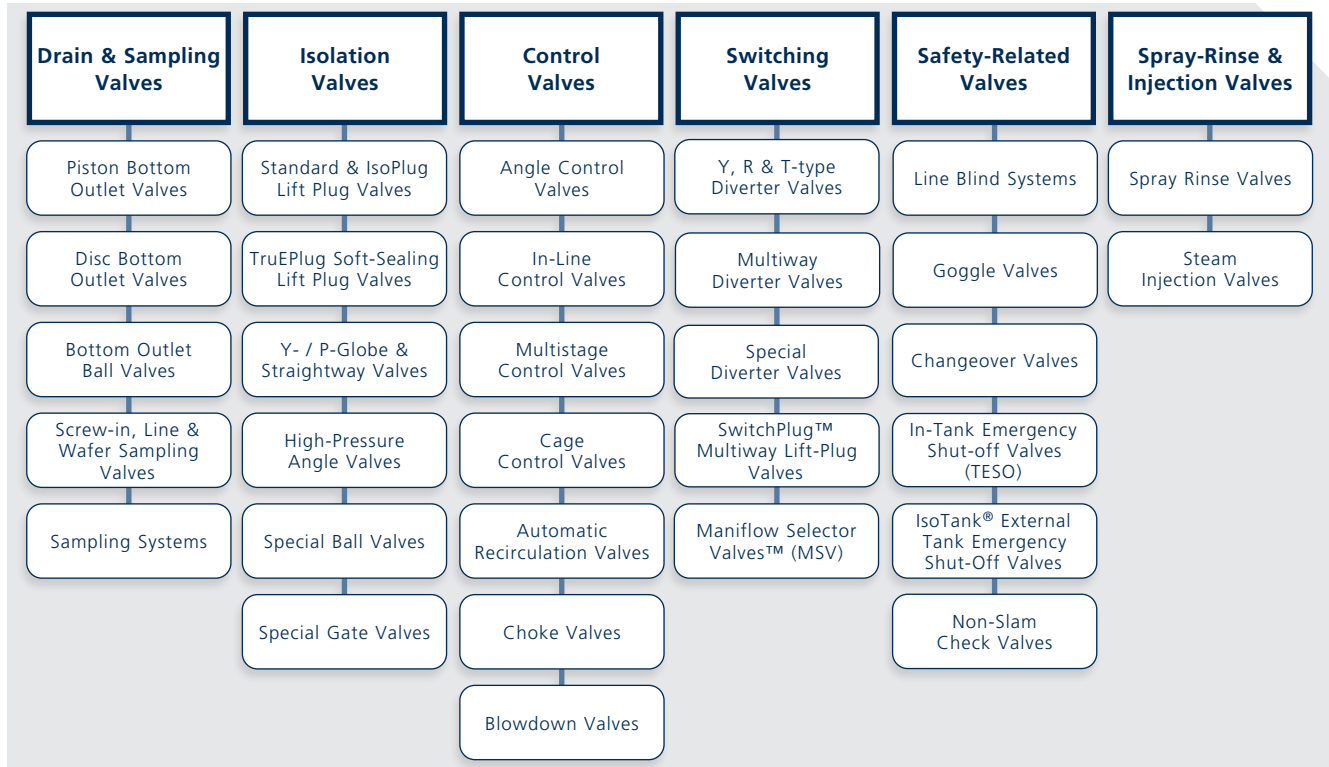

Key Client List:

- | | | |
|------------------|---------------------|------------------|
| ■ ADNOC | ■ Glaxo Smith Kline | ■ Reliance |
| ■ AkzoNobel | ■ INEOS | ■ Roche |
| ■ AstraZeneca | ■ Invista | ■ SABIC |
| ■ BASF | ■ Jiangsu Hengli | ■ Saipem |
| ■ Bayer | ■ Lanxess | ■ Salavat |
| ■ BP | ■ LG Chemical | ■ Samsung |
| ■ Chevron | ■ Linde | ■ Sanofi Aventis |
| ■ Clariant | ■ Lotte Chemical | ■ SASA |
| ■ DOW Chemical | ■ Lukoil | ■ Shell |
| ■ Du Pont | ■ Lurgi | ■ Shin Etsu |
| ■ Eastman | ■ Merck | ■ Sinopec |
| ■ Evonik | ■ Novartis | ■ Sulzer |
| ■ Exxon Chemical | ■ Oerlikon | ■ Temex |
| ■ FCFC | ■ Oxy Vinyls | ■ Tuntex |
| ■ Far Eastern | ■ Pemex | ■ Uhde |
| ■ Foster Wheeler | ■ Petrobras | ■ Vinnolit |
| ■ GE | ■ Pfizer | |

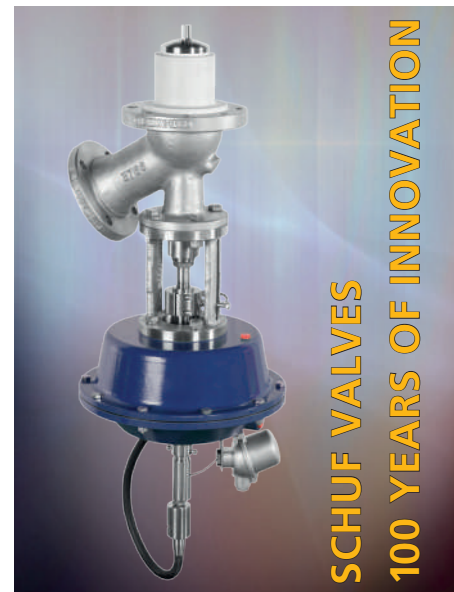

SchuF Worldwide

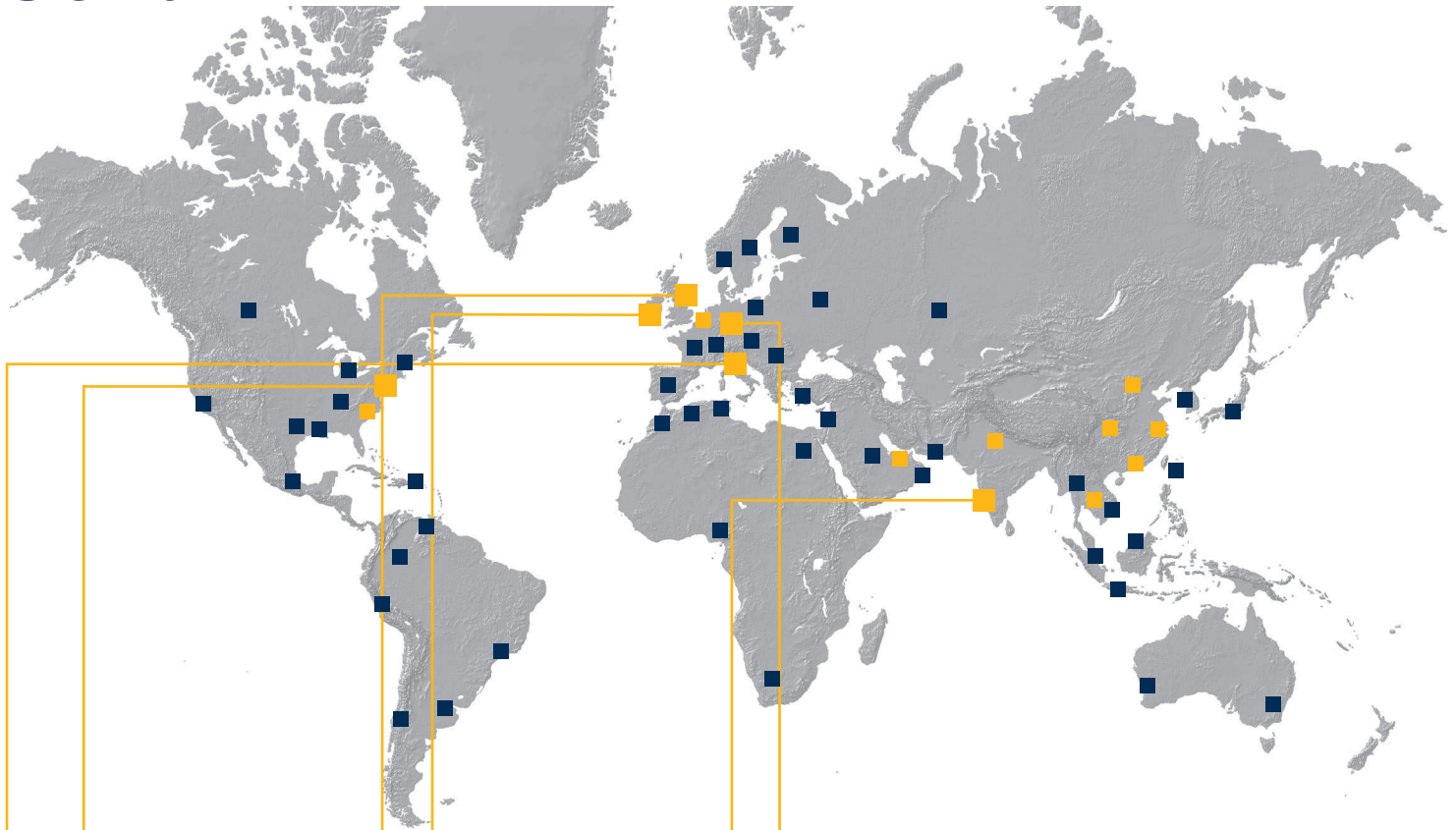

www.schuf.com

www.schuf.de

USA



Fetterolf Corporation
phone: +1 610 584-1500
info@fetterolfvalves.com

SchuF (USA) Inc.
phone: +1 843 8813345
sales@schuf.us

IRELAND



SchuF Valve Technology GmbH
phone: +353 (0)21 4837000
sales@schuf.ie

GERMANY



**SchuF Chemieventile
Vertriebs GmbH & Co.KG**
phone: +49 6198 571 100
sales@schuf.com

Your Sales Channel:

SchuF Benelux B.V.
phone +31 25 12 34 448
lmulder@schuf.com

SchuF Middle East F.Z.C.
phone: +971 58 662 0873
ecalnan@schuf.com

SchuF South East Asia Pte. Ltd.
phone +31 620 62 66 64
mmulder@schuf.com

SchuF Valves China Ltd.
phone +86 27 8331 6569
schufchina@schuf.com

ITALY



La Tecnovalvo S.r.l.
phone: +39 023 503 508
info@latecnovalvo.com

UNITED KINGDOM



SchuF (UK) Ltd.
phone: +44 203 355 2012
sales@schuf.co.uk

INDIA



**SchuF Speciality Valves
India Pvt. Ltd.**
phone: +91 421 226 4600
sales@schuf-india.com

Your Local Agent: