

TwisTorr 84 FS AG Rack Controller

Models

X3508-64001, X3508-64002

Manuale di istruzioni
Bedienungshandbuch
Notice de mode d'emploi
Manual de instrucciones
Manual de instruções
Bedrijfshandleiding
Istruktionsbog
Bruksanvisning

Instruksjon manual
Ohjekäsikirja
Felhasználói kézikönyv
Podrecznik instrukcji
Návod k použití
Návod na obsluhu
Priročnik za navodila
User Manual

87-901-037-01 (E)

02/2019



Agilent Technologies

Notices

© Agilent Technologies, Inc. 2019

No part of this manual may be reproduced in any form or by any means (including electronic storage and retrieval or translation into a foreign language) without prior agreement and written consent from Agilent Technologies, Inc. as governed by United States and international copyright laws.

Manual Part Number

Publication Number: 87-901-037-01 (E)

Edition

Edition 02/2019

Printed in ITALY

Agilent Technologies Italia S.p.A.

Vacuum Products Division

Via F.lli Varian, 54

10040 Leini (TO)

ITALY

Warranty

The material contained in this document is provided “as is,” and is subject to being changed, without notice, in future editions. Further, to the maximum extent permitted by applicable law, Agilent disclaims all warranties, either express or implied, with regard to this manual and any information contained herein, including but not limited to the implied warranties of merchantability and fitness for a particular purpose. Agilent shall not be liable for errors or for incidental or consequential damages in connection with the furnishing, use, or performance of this document or of any information contained herein. Should Agilent and the user have a separate written agreement with warranty terms covering the material in this document that conflict with these terms, the warranty terms in the separate agreement shall control.

Technology Licenses

The hardware and/or software described in this document are furnished under a license and may be used or copied only in accordance with the terms of such license.

Restricted Rights Legend

If software is for use in the performance of a U.S. Government prime contract or subcontract, Software is delivered and licensed as “Commercial computer software” as defined in DFAR 252.227-7014 (June 1995), or as a “commercial item” as defined in FAR 2.101(a) or as “Restricted computer software” as defined in FAR 52.227-19 (June 1987) or any equivalent agency regulation or

contract clause. Use, duplication or disclosure of Software is subject to Agilent Technologies’ standard commercial license terms, and non-DOD Departments and Agencies of the U.S. Government will receive no greater than Restricted Rights as defined in FAR 52.227-19(c)(1-2) (June 1987). U.S. Government users will receive no greater than Limited Rights as defined in FAR 52.227-14 (June 1987) or DFAR 252.227-7015 (b)(2) (November 1995), as applicable in any technical data.

Trademarks

Windows and MS Windows are U.S. registered trademarks of Microsoft Corporation.

Safety Notices

CAUTION

A **CAUTION** notice denotes a hazard. It calls attention to an operating procedure, practice, or the like that, if not correctly performed or adhered to, could result in damage to the product or loss of important data. Do not proceed beyond a **CAUTION** notice until the indicated conditions are fully understood and met.

WARNING

A **WARNING** notice denotes a hazard. It calls attention to an operating procedure, practice, or the like that, if not correctly performed or adhered to, could result in personal injury or death. Do not proceed beyond a **WARNING** notice until the indicated conditions are fully understood and met.

TwisTorr 84 FS AG Rack Controller



Contents

1 Istruzioni per l'uso 15

Informazioni Generali	16
Immagazzinamento	17
Preparazione per l'installazione	18
Installazione	19
Uso	20
Procedure di uso	23
Manutenzione	23
Smaltimento	24
Messaggi di errore	25

2 Gebrauchsanleitung 27

Allgemeines	28
Lagerung	29
Vor der Installation	30
Installation	31
Gebrauch	32
Bedienung	35
Wartung	35
Entsorgung	36

Contents

	Fehlermeldungen	36
3	Mode d'emploi	39
	Indications générales	40
	Emmagasinage	41
	Préparation pour l'installation	42
	Installation	43
	Utilisation	44
	Procédures d'utilisation	47
	Entretien	47
	Mise au rebut	48
	Messages d'erreur	48
4	Manual de instrucciones	51
	Información general	52
	Almacenamiento	53
	Preparación para la instalación	54
	Instalación	55
	Uso	56
	Procedimientos de uso	59
	Mantenimiento	59
	Eliminación	60
	Mensajes de error	60

5	Manual de Instruções	63
	Informações gerais	64
	Armazenagem	65
	Preparação para a instalação	66
	Instalação	67
	Utilização	68
	Procedimentos de uso	71
	Manutenção	71
	Eliminação	72
	Mensagens de erro	73
6	Bedrijfshandleiding	75
	Algemene informatie	76
	Opslag	77
	Vorbereiding voor installatie	78
	Installatie	79
	Gebruik	80
	Gebruiksprocedures	83
	Onderhoud	83
	Afvalverwerking	84
	Foutmeldingen	85
7	Istruktionsbog	87
	Generel Information	88

Contents

Opbevaring	89
Forberedelser før installation	90
Installation	91
Anvendelse	92
Instruktion	95
Vedligeholdelse	95
Bortskaffelse	96
Fejlmeddelelser	97
8 Bruksanvisning	99
Allmän Information	100
Förvaring	101
Forberedelser för installation	102
Installation	103
Användning	104
Instruktioner för bruk	107
Underhåll	107
Bortskaffning	108
Felmeddelanden	109
9 Instruksjon Manual	111
Generell informasjon	112
Lagring	113
Forberede installasjonen	114

Installasjon	115
Bruk	116
Instruksjoner for bruk	119
Vedlikehold	119
Eliminering	120
Feilmeldinger	121
10 Ohjekäsikirja	123
Yleisiä tietoja	124
Varastointi	125
Valmistelut asennusta varten	126
Asennus	127
Käyttö	128
Käyttötoimenpiteet	131
Huolto	131
Hävittäminen	132
Vianetsintä	133
11 Felhasználói Kézikönyv	135
Általános információk	136
Tárolás	137
A telepítésre való előkészítés	138
Telepítés	139
Használat	140

Contents

Használati eljárások	143
Karbantartás	143
Megsemmisítés	144
Hibaüzenetek	144
12 Podrecznik Instrukcji	147
Informacje ogólne	148
Magazynowanie	149
Przygotowanie do instalacji	150
Instalacja	151
Użytkowanie	152
Procedure użytkowania	155
Konserwacja	155
Przetworstwo odpadów	156
Błędne informacje	156
13 Návod k Použití	159
Všeobecné informace	160
Uskladnění	161
Příprava k instalaci	162
Instalace	163
Použití	164
Používané procedury	167
Údržba	167

Likvidace	168
Chybné zprávy	168
14 Návod na Obsluhu	171
Všeobecné informácie	172
Uskladňovanie	173
Príprava pre inštaláciu	174
Inštalácia	175
Použitie	176
Postup pri použití	179
Údržba	179
Likvidácia	180
Oznamy väd	180
15 Príročník za Navodila	183
Splošne informacije	184
Skladiščenje	185
Priprava za montažo	186
Montaža	187
Uporaba	188
Postopki uporabe	191
Vzdrževanje	191
Odlaganje odpadkov	192
Obvestilo o napaki	193

Contents

16	Instructions for Use	195
	General Information	196
	Storage	197
	Preparation for Installation	198
	Installation	199
	Use	200
	Use Procedure	203
	Maintenance	203
	Disposal	204
	Error Messages	204
17	Technical Information	207
	TwisTorr 84 FS AG Rack Controller Description	209
	Controller Specifications	211
	Controller Outline	212
	Controller Connection	213
	R1 – R2 Output Diagrams	220
	Programmable Analog Output Diagrams	223
	J2 – Serial Connector	228
	Letter Protocol Description	231
	Examples	240
	How to Use by Front Panel	248
	Use	253

Programming	260
How to Use by Remote I/O	273
How to Use in Serial Mode	273
Profibus Option	275
Error Messages	290
Orderable Parts	294

Contents



1 Istruzioni per l'uso

Informazioni Generali	16
Immagazzinamento	17
Preparazione per l'installazione	18
Installazione	18
Uso	20
Comandi, Indicatori e Connettori	21
Descrizione pannello frontale	21
Procedure di uso	21
Accensione del Controller	23
Avvio della Pompa	23
Arresto della Pompa	23
Manutenzione	23
Smaltimento	23
Messaggi di errore	25

Traduzione delle istruzioni originali



Informazioni Generali

Questa apparecchiatura è destinata ad uso professionale. L'utilizzatore deve leggere attentamente il presente manuale di istruzioni ed ogni altra informazione addizionale fornita dalla Agilent prima dell'utilizzo dell'apparecchiatura. La Agilent si ritiene sollevata da eventuali responsabilità dovute all'inosservanza totale o parziale delle istruzioni, ad uso improprio da parte di personale non addestrato, ad interventi non autorizzati o ad uso contrario alle normative nazionali specifiche. I controller della serie TwisTorr 84 FS AG Rack sono dei convertitori di frequenza, controllati da un microprocessore, realizzati con componenti a stato solido e con capacità di autodiagnostica e autoprotezione.

Caratteristiche del controller:

- Operatività frontale / remota / seriale
- Pilotaggio a 24 Vdc della ventola di raffreddamento pompa
- Pilotaggio vent valve
- Lettura velocità pompa in seguito al comando di arresto (lettura velocità di arresto)
- Lettura della pressione
- Interfaccia Profibus (opzionale)
- Impostazione automatica tensione di ingresso.

Nei paragrafi seguenti sono riportate tutte le informazioni necessarie a garantire la sicurezza dell'operatore durante l'utilizzo dell'apparecchiatura. Informazioni dettagliate sono fornite nell'appendice "Technical Information".

Questo manuale utilizza le seguenti convenzioni:

AVVERTENZA!



I messaggi di avvertenza attirano l'attenzione dell'operatore su una procedura o una pratica specifica che, se non eseguita in modo corretto, potrebbe provocare gravi lesioni personali.

ATTENZIONE!

I messaggi di attenzione sono visualizzati prima di procedure che, se non osservate, potrebbero causare danni all'apparecchiatura.

NOTA

Le note contengono informazioni importanti estrapolate dal testo.

Immagazzinamento

Durante il trasporto e l'immagazzinamento dei controller devono essere soddisfatte le seguenti condizioni ambientali:

- temperatura: da -20 °C a +70 °C
- umidità relativa: 0 – 95 % (non condensante)

Preparazione per l'installazione

Il controller viene fornito in un imballo protettivo speciale; se si presentano segni di danni, che potrebbero essersi verificati durante il trasporto, contattare l'ufficio vendite locale.

Durante l'operazione di disimballaggio, prestare particolare attenzione a non lasciar cadere il controller e a non sottoporlo ad urti.

Non disperdere l'imballo nell'ambiente. Il materiale è completamente riciclabile e risponde alla direttiva CEE 85/399 per la tutela dell'ambiente.



Figura 1 Imballo del controller

Installazione

AVVERTENZA!

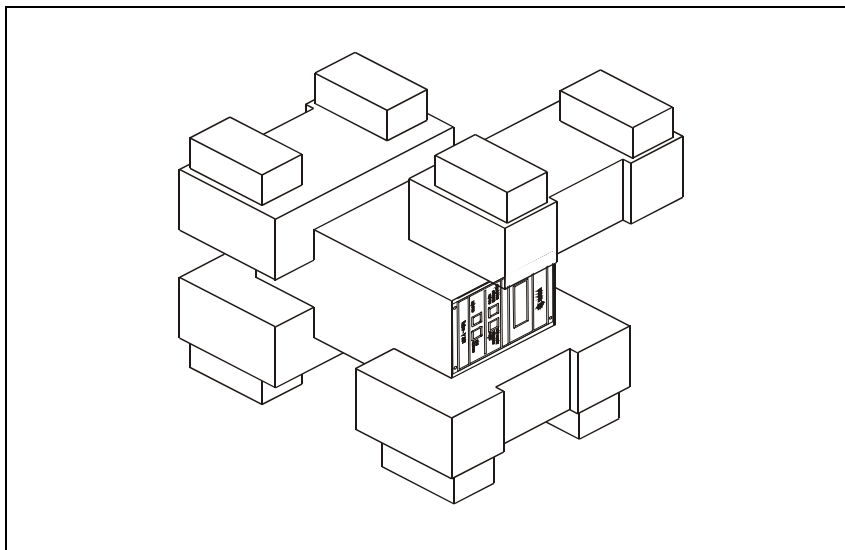

Il controller è progettato solo per uso interno e deve essere alimentato mediante un cavo di alimentazione a tre fili (vedere tabella delle parti ordinabili) con una spina di tipo approvato a livello internazionale ai fini della sicurezza dell'utente. Utilizzare sempre questo cavo di alimentazione ed inserire la spina in una presa con un adeguato collegamento di terra onde evitare scariche elettriche e per rispettare le specifiche CE. All'interno del controller si sviluppano alte tensioni che possono recare gravi danni o la morte. Prima di eseguire qualsiasi operazione di installazione o manutenzione del controller scollegarlo dalla presa di alimentazione.

NOTA

Il controller può essere installato su di un tavolo o all'interno di un apposito rack. In ogni caso occorre che l'aria di raffreddamento possa circolare liberamente intorno all'apparato. Non installare né utilizzare il controller in ambienti esposti ad agenti atmosferici (pioggia, gelo, neve), polveri, gas aggressivi, in ambienti esplosivi o con elevato rischio di incendio.

Durante il funzionamento è necessario che siano rispettate le seguenti condizioni ambientali:

- temperatura: da 5 °C a +45 °C;
- umidità relativa: 0 – 95 % (non condensante).

Per gli altri collegamenti e l'installazione degli accessori opzionali, vedere la sezione "Technical Information".

1 Istruzioni per l'uso

Uso

Uso

In questo paragrafo sono riportate le principali procedure operative. Per ulteriori dettagli e per procedure che coinvolgono collegamenti o particolari opzionali, fare riferimento al paragrafo "Use" dell'appendice "Technical Information".

Prima di usare il controller effettuare tutti i collegamenti elettrici e pneumatici e fare riferimento al manuale della pompa collegata.

AVVERTENZA!

Fare riferimento al manuale relativo alla pompa in questione per utilizzarla in modo sicuro prima dell'avviamento.



NOTA

Il connettore di richiusura J1 deve essere lasciato collegato con il suo ponticello se non viene effettuato alcun collegamento esterno. La pompa di pre-vuoto e la pompa TwisTorr possono essere accese contemporaneamente.

Comandi, Indicatori e Connettori

Di seguito sono illustrati il pannello di comando del Controller ed i pannelli di interconnessione. Per maggiori dettagli fare riferimento alla sezione "Technical Information".

Descrizione pannello frontale



Figura 2 Pannello frontale del Controller TwisTorr 84 FS AG

1	Pulsante per richiamare sul display i parametri cycle number, cycle time e pump life.
2	Pulsante per la selezione del modo LOW SPEED. È attivo solo quando è selezionato il modo di comando dal pannello frontale. Premendolo una volta, la pompa ruota a velocità "stand-by". Premendolo ancora si disattiva il modo LOW SPEED.
3	Pulsante per richiamare sul display i parametri "pump current", "pump temperature", "pump power" e "rotational speed". È sempre attivo indipendentemente dal modo di funzionamento scelto. Premendo assieme i pulsanti 3 e 1 per almeno 2 secondi viene attivato un programma con il quale è possibile programmare alcuni parametri operativi.
4	Pulsante per inviare i comandi di START, STOP/RESET. È attivo solo quando è selezionato il modo di comando dal pannello frontale. Premendolo una volta si attiva la fase di avvio; premendolo nuovamente si arresta la pompa. Se la pompa si è fermata automaticamente a causa di un guasto, occorre premere questo pulsante una prima volta per eseguire il reset del controller ed una seconda volta per riavviare la pompa.
5	Display alfanumerico a cristalli liquidi: matrice di punti, 2 linee x 16 caratteri.

1 Istruzioni per l'uso

Uso

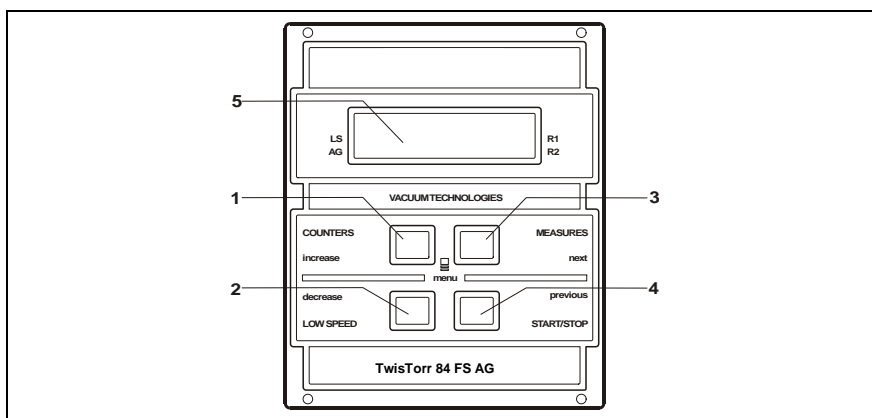

Figura 3 Pannello posteriore dei Controller TwisTorr 84 FS AG

1	Connettore di ingresso dei segnali logici (il connettore di accoppiamento viene fornito con l'apposito ponticello di richiusura).
2	Connettore segnali logici in uscita e monitoraggio frequenza pompa più uscita analogica programmabile.
3	Connettore di uscita alimentazione (24 Vdc per la ventola di raffreddamento pompa, vent valve e gauge).
4	Modulo di ingresso alimentazione controller che comprende i fusibili, la presa di alimentazione ed il filtro ENC.
5	Switch a rotazione per impostare l'indirizzo del Profibus (opzionale).
6	Profibus (opzionale).
7	Connettore seriale per controllo da remoto.
8	Cavo pompa (lungo 5 m).

Procedure di uso

Accensione del Controller

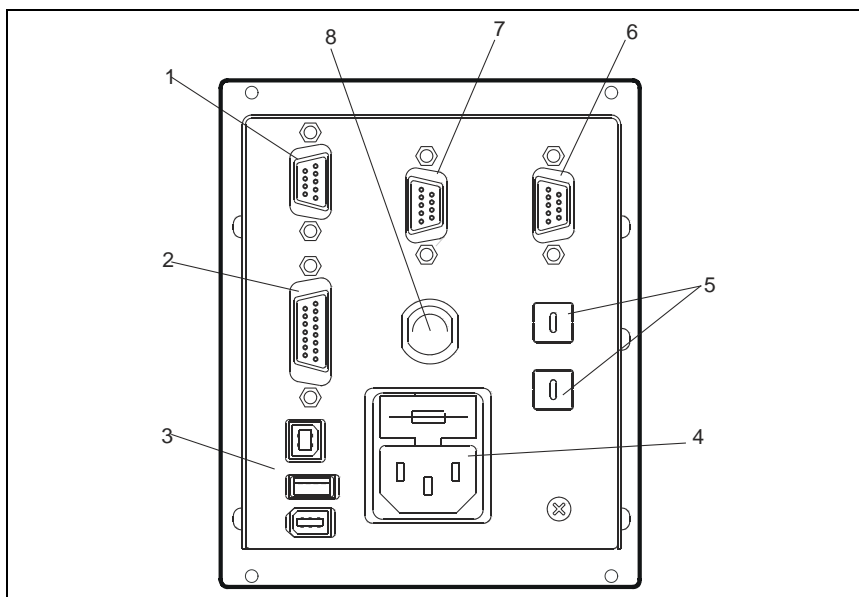
Per accendere il controller è sufficiente inserire il cavo di alimentazione nella presa di rete.

Avvio della Pompa

Per avviare la pompa, confermare l'input di interblocco (barrette di cortocircuito 3÷8 su P1) e premere il pulsante START sul pannello di comando anteriore.

Arresto della Pompa

Per arrestare la pompa occorre premere il pulsante STOP del pannello frontale.

Manutenzione

I controller della serie TwisTorr 84 FS AG Rack non richiedono alcuna manutenzione. Qualsiasi intervento deve essere eseguito da personale autorizzato. In caso di guasto è possibile usufruire del servizio di riparazione Agilent o del "Agilent advanced exchange service", che permette di ottenere un controller rigenerato in sostituzione di quello guasto.

AVVERTENZA!



Prima di effettuare qualsiasi intervento sul controller scollegare il cavo di alimentazione.

Se un controller deve essere eliminato, occorre smaltirlo conformemente agli standard nazionali specifici.

Smaltimento

Significato del logo "WEEE" presente sulle etichette. Il simbolo qui sotto riportato è applicato in ottemperanza alla direttiva CE denominata "WEEE". Questo simbolo (**valido solo per i paesi della Comunità Europea**) indica che il prodotto sul quale è applicato, NON deve essere smaltito insieme ai comuni rifiuti domestici o industriali, ma deve essere avviato ad un sistema di raccolta differenziata. Si invita pertanto l'utente finale a contattare il fornitore del dispositivo, sia esso la casa madre o un rivenditore, per avviare il processo di raccolta e smaltimento, dopo opportuna verifica dei termini e condizioni contrattuali di vendita.



Per maggiori informazioni riferirsi a:

<http://www.agilent.com/environment/product/index.shtml>

Messaggi di errore

Il controller eseguirà l'autodiagnosi di alcune cause d'errore e mostrerà i seguenti messaggi.

Tab. 1

MESSAGGIO	DESCRIZIONE	AZIONE CORRETTIVA
CHECK CONNECTION TO PUMP	Malfunzionamento nel collegamento tra pompa e controller. Oppure La pompa ha una temperatura inferiore a 0 °C.	Verificare che il cavo di collegamento tra pompa e controller sia ben fissato da entrambe le estremità e non sia interrotto. Premere due volte il pulsante START per riavviare la pompa.
WAITING INTERLOCK	È attivo il segnale di interlock presente sul connettore P1 a causa dell'interruzione del corto circuito tra il pin 3 ed il pin 8 del connettore J1, o a causa dell'apertura del segnale di interlock esterno.	Collegare il pin 3 al pin 8 del connettore P1, oppure chiudere il segnale esterno di interblocco.
PUMP OVERTEMP.	La temperatura del cuscinetto superiore o della pompa ha superato i 60 °C.	Attendere che la temperatura ritorni al di sotto della soglia. Premere due volte il pulsante START per riavviare la pompa.
CONTROLLER OVERTEMP.	La temperatura dell'ambiente del controller ha superato i 70 °C. Oppure. La temperatura del radiatore del controller è superiore a 60 °C.	Attendere che la temperatura ritorni al di sotto della soglia. Premere due volte il pulsante START per riavviare la pompa.

1 Istruzioni per l'uso

Messaggi di errore

MESSAGGIO	DESCRIZIONE	AZIONE CORRETTIVA
TOO HIGH LOAD	La corrente ricevuta dalla pompa è troppo alta.	Verificare che il rotore della pompa abbia la possibilità di ruotare liberamente. Premere due volte il pulsante START per riavviare la pompa.
SHORT CIRCUIT	Un cortocircuito è presente sul connettore della pompa.	Controllare i collegamenti e i cortocircuiti tra la pompa e il controller. Premere due volte il pulsante START per riavviare la pompa.
SYSTEM OVERRIDE	La pompa è stata fermata da un segnale di emergenza proveniente da un contatto remoto.	Staccare il cavo di alimentazione del controller e correggere la causa dell'emergenza. Ricollegare il cavo di alimentazione e premere due volte il pulsante START per riavviare la pompa.
OVERVOLTAGE	La circuiteria di alimentazione elettrica del controller è difettosa oppure il Controller ha ricevuto una tensione eccessiva imprevista.	Premere due volte il pulsante START per riavviare la pompa. Se il messaggio si ripresenta rivolgersi in Agilent per la manutenzione.
POWER FAIL	Guasto della sezione di alimentazione elettrica.	Rivolgersi alla Agilent per Manutenzione.

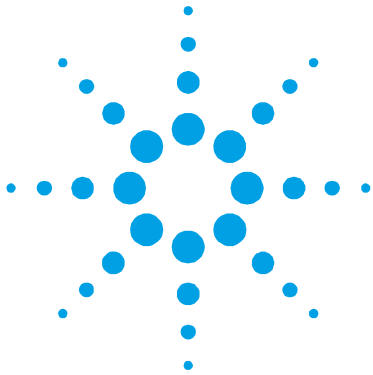

2 Gebrauchsanleitung

Allgemeines	28
Lagerung	29
Vor der Installation	30
Installation	31
Gebrauch	32
Steuerungen, Anzeigen und Verbinder des Controllers	32
Fronttafel der Controller	33
Bedienung	35
Einschalten des Controllers	35
Pumpenstart	35
Pumpenstopp	35
Wartung	35
Entsorgung	36
Fehlermeldungen	36

Übersetzung der Originalanleitungen



Allgemeines

Dieser Apparat ist für Fachbetriebe bestimmt. Vor Gebrauch sollte der Benutzer dieses Handbuch sowie alle weiteren mitgelieferten Zusatzdokumentationen genau lesen. Bei Nichtbeachtung - auch teilweise - der enthaltenen Hinweise, unsachgemäßem Gebrauch durch ungeschultes Personal, nicht autorisierten Eingriffen und Mißachtung der einheimischen, hier zur Geltung kommenden Bestimmungen übernimmt die Firma Agilent keinerlei Haftung.

Die Controller der Serie TwisTorr 84 FS AG Rack sind mikroprozessorgesteuerte Frequenzwandler. Sie sind mit Festkörperbauteilen gefertigt und verfügen über ein Selbstdiagnose- und ein Selbstschutzsystem.

Controllereigenschaften:

- Steuerbar direkt via Frontpaneel, Fernsteuerbar via analog / seriell
- Pumpkühlungsventilatoranschluß (24V)
- Belüftungsventilsteuerung
- Auslesen der Pumpgeschwindigkeit nach Stoppbefehl (Lesen der Stoppgeschwindigkeit)
- Auslesen des Drucks
- Profibus-Schnittstelle (Option)
- automatische Einstellung der Eingangsspannung

In den folgenden Abschnitten sind alle erforderlichen Informationen für die Sicherheit des Bedieners bei der Anwendung des Geräts aufgeführt. Detaillierte technische Informationen sind im Anhang "Technical Information" enthalten.

In dieser Gebrauchsanleitung werden Sicherheitshinweise folgendermaßen hervorgehoben:

WARNUNG!



Die Warnhinweise lenken die Aufmerksamkeit des Bedieners auf eine bestimmte Prozedur oder Praktik, die bei unkorrekter Ausführung schwere Verletzungen hervorrufen können.

VORSICHT!

Die Vorsichtshinweise vor bestimmten Prozeduren machen den Bediener darauf aufmerksam, daß bei Nichteinhaltung Schäden an der Anlage entstehen können.

HINWEIS

Die Hinweise enthalten wichtige Informationen, die aus dem Text hervorgehoben werden.

Lagerung

Beim Transport und bei der Lagerung der Controller müssen folgende klimatische Verhältnisse eingehalten werden:

- Temperatur: von -20 °C bis +70 °C
- Relative Luftfeuchtigkeit: 0 – 95 % (nicht kondensierend)

Vor der Installation

Der Controller wird mit einer speziellen Schutzverpackung geliefert. Eventuelle Transportschäden müssen der zuständigen örtlichen Verkaufsstelle gemeldet werden.

Beim Auspacken vorsichtig vorgehen, damit der Controller nicht fällt oder Stößen ausgesetzt wird.

Das Verpackungsmaterial muß korrekt entsorgt werden. Es ist vollständig recyclebar und entspricht der EG-Richtlinie 85/399 für Umweltschutz.



Abbildung 1 Verpackung des Controllers

Installation

WARNUNG!

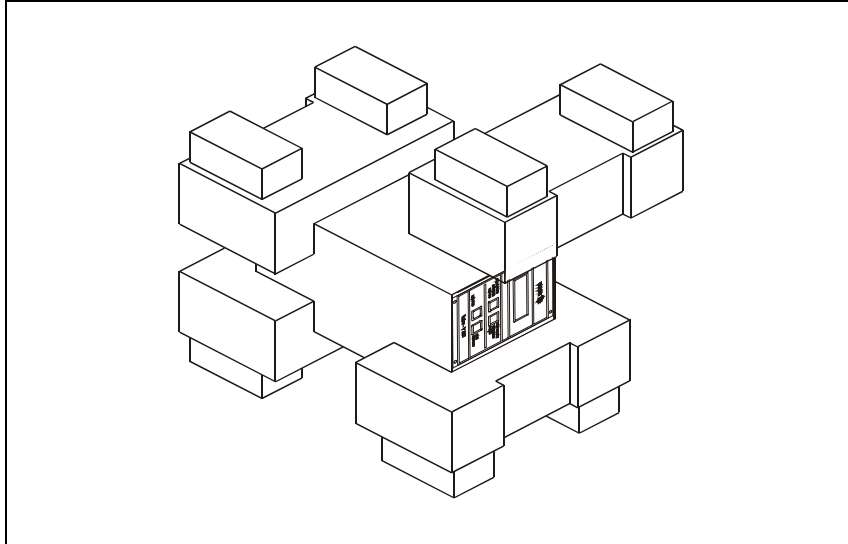

Der TwisTorr Controller muss mit einem dreiadrigen Netzkabel und dem (international zugelassenen) Stecker angeschlossen werden. Es sollte immer dieses Netzkabel benutzt werden, das an eine korrekt geerdete Steckdose anzuschließen ist, um den CE Richtlinien zu entsprechen und Stromschläge zu vermeiden. Im Inneren des Controllers entstehen hohe Spannungen, die schwere Verletzungen verursachen und lebensgefährlich sein können. Vor jedem Montage- bzw. Wartungseingriff muss deshalb der Netzstecker gezogen werden.

HINWEIS

Der Controller kann auf einen Tisch oder ein Gestell montiert werden. In beiden Fällen muß auf die ungehinderte Zirkulation der Kühlluft im Bereich des Geräts geachtet werden. Der Controller darf nicht in Umgebungen installiert u/o benutzt werden, die Witterungseinflüssen (Regen, Frost, Schnee), Staub und aggressiven Gasen ausgesetzt sind und in denen Explosions- und erhöhte Brandgefahr besteht.

Beim Betrieb müssen folgende Umgebungsbedingungen eingehalten werden:

- Temperatur: von +5 °C bis +45 °C
- Relative Luftfeuchtigkeit: 0 – 95 % (nicht kondensierend).

Gebrauch

In diesem Kapitel sind die wichtigsten Betriebsvorgänge aufgeführt. Für weitere Hinweise bezüglich Anschlüsse und Montage des bestellbaren Zubehörs siehe Kapitel "Use" im Anhang zu "Technical Information".

Vor Benutzung des Controllers sämtliche elektrischen und pneumatischen Anschlüsse ausführen, und die Betriebsanleitung der angeschlossenen Pumpe durchlesen.

WARNUNG!



Bevor Sie die fragliche Pumpe in Betrieb setzen, beachten Sie zu Ihrer Sicherheit bitte die Hinweise im entsprechenden Handbuch.

HINWEIS

Der Wiederverschließ-Verbinder J1 muß mit seiner Brücke angeschlossen bleiben, wenn kein externer Anschluß erfolgt. Die Vorvakuumpumpe und die TwisTorr-Pumpe können gleichzeitig eingeschaltet werden.

Steuerungen, Anzeigen und Verbinder des Controllers

Der folgende Abschnitt beschreibt die vordere und hintere Konsole des Controllers. Für weitere Einzelheiten siehe "Technical Information".

Fronttafel der Controller



Abbildung 2 Frontpaneel des Controllers TwisTorr 84 FS AG

1	Taste für die Anzeige der Parameter "cycle number", "cycle time" und "pump life".
2	Taste für die Einstellung des Modus LOW SPEED. Sie ist nur aktiv, wenn der Steuermodus auf Fronttafel eingestellt ist. Bei einmaligem Drücken läuft die Pumpe in Bereitschafts-Geschwindigkeit. Bei nochmaligem Drücken wird der Modus LOW SPEED deaktiviert.
3	Taste für die Anzeige der Parameter "pump current", "pump temperature", "pump power" und "rational speed". Sie ist immer aktiv, unabhängig vom gewählten Betriebsmodus. Bei gemeinsamer, mindestens 2 Sekunden langer Betätigung der Tasten 3 und 1 wird ein Programm aktiviert, mit dem einige Betriebsparameter programmiert werden können.
4	START-, STOP/RESET-Taste. Sie ist nur aktiv, wenn der Steuermodus auf der Fronttafel eingestellt ist. Bei einmaligem Drücken wird die Startphase aktiviert. Bei nochmaligem Drücken stoppt die Pumpe. Bei automatischem Pumpenstopp durch Störung muß diese Taste ein erstes Mal zur Controller-Rücksetzung und dann ein zweites Mal zum Neustarten der Pumpe gedrückt werden.
5	Alphanumerisches Flüssigkristall-Display: Punkt-matrix, 2 Zeilen mit 16 Stellen.

2 Gebrauchsanleitung

Gebrauch

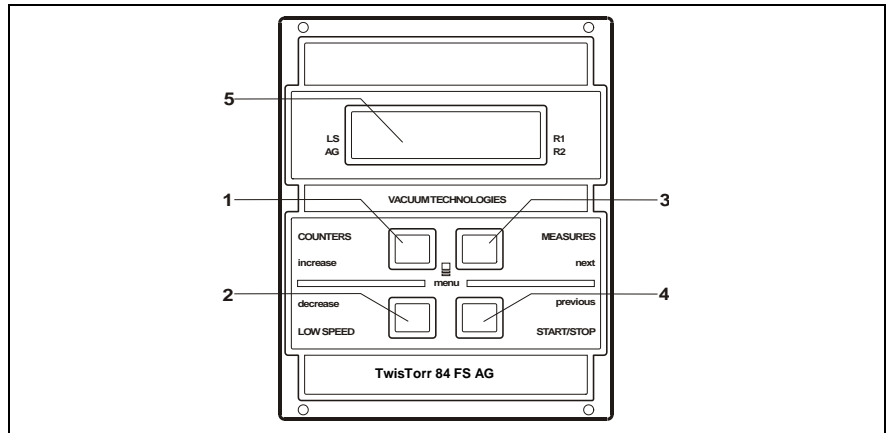

Abbildung 3 Rückseite des Controllers TwisTorr 84 FS AG

1	Eingangstecker der logischen Signale (passende Buchse wird mit geliefert).
2	Ausgangssignalebene (logische Signale, Pumpfrequenz, Analogsignale).
3	Stromausgangsstecker (24 V= Pumpkühlventilator, Belüftungsventil und Druckmeßröhre).
4	Netzeingangsmodul des Controllers bestehend aus Netzsicherungen, Netzstecker und EMC Filter.
5	Drehschalter zum Setzen der Profibus Adresse (Option).
6	Profibus (Option).
7	Serieller Stecker zur Fernsteuerung.
8	Pumpkabel (5m lang).

Bedienung

Einschalten des Controllers

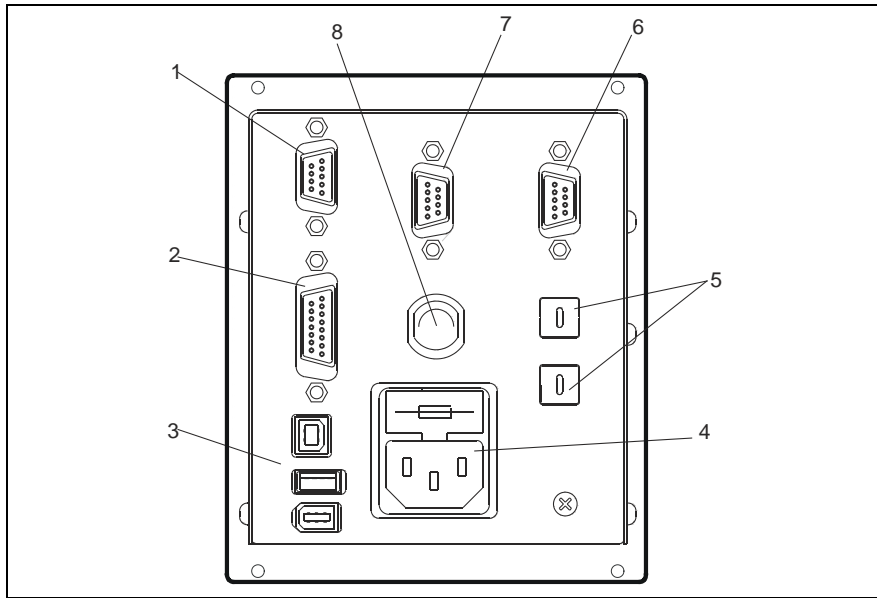
Zum Einschalten des Controllers genügt es, das Netzkabel an die Steckdose anzuschließen.

Pumpenstart

Um die Pumpe zu starten, bestätigen Sie den Verriegelungseingang (Stifte um 3 ÷ 8 an P1 kürzen) und drücken Sie die Start-Taste auf dem Bedienfeld.

Pumpenstopp

Zum Stoppen der Pumpe muß die STOP-Taste an der Fronttafel gedrückt werden.

Wartung

Die Controller der Serie TwisTorr 84 FS AG Rack sind wartungsfrei. Eventuell erforderliche Eingriffe müssen von dazu befugtem Fachpersonal ausgeführt werden. Bei einem Defekt kann der Agilent-Reparaturdienst bzw. der "Agilent advanced exchange service" in Anspruch genommen werden, der für die Erneuerung defekter Controller sorgt.

WARNUNG! Vor jedem Eingriff am Controller muß der Netzstecker gezogen werden.



Wenn ein Controller verschrottet werden muss, muss er entsprechend der spezifischen nationalen Vorschriften entsorgt werden.

Entsorgung

Bedeutung des "WEEE" Logos auf den Etiketten. Das folgende Symbol ist in Übereinstimmung mit der EU-Richtlinie WEEE (Waste Electrical and Electronic Equipment) angebracht. Dieses Symbol (**nur in den EU-Ländern gültig**) zeigt an, dass das betreffende Produkt nicht zusammen mit Haushaltsmüll entsorgt werden darf sondern einem speziellen Sammelsystem zugeführt werden muss. Der Endabnehmer sollte daher den Lieferanten des Geräts - d.h. die Muttergesellschaft oder den Wiederverkäufer - kontaktieren, um den Entsorgungsprozess zu starten, nachdem er die Verkaufsbedingungen geprüft hat.



Weitere Informationen finden Sie unter:

<http://www.agilent.com/environment/product/index.shtml>

Fehlermeldungen

Der Controller wird einige Fehlerursachen selbst diagnostizieren und folgende Mitteilungen anzeigen:

Tab. 1

MELDUNG	BESCHREIBUNG	BEHEBUNG
CHECK CONNECTION TO PUMP	Fehlfunktion der Pumpen-Controller Verbindung. Oder Die Temperatur der Pumpe ist unter 0 °C.	Sicherstellen, daß das Verbindungskabel zwischen Pumpe und Controller an beiden Seiten korrekt befestigt ist und keine Unterbrechung vorliegt. Die Pumpe durch zweimalige Betätigung der START-Taste neustarten.
WAITING INTERLOCK	Das Interlock-Signal auf dem Verbinder P1 ist wegen der Kurzschluß-unterbrechung zwischen Pin 3 und Pin 8 des Verbinders K1 oder wegen der Öffnung des externen Interlock-Signals aktiv.	Verbinden Sie den Stift 3 mit Stift 8 des P1 Anschlusses oder schließen Sie das externe Verriegelungssignal.
PUMP OVERTEMP.	Die Temperatur des oberen Lagers bzw. der Pumpe hat 60 °C überschritten.	Warten bis die Temperatur unter den Schwellenwert gesunken ist. Die Pumpe durch zweimalige Betätigung der START-Taste neustarten.
CONTROLLER OVERTEMP.	Die Temperatur des Controllers hat 70 °C überschritten. Oder Die Temperatur des Controller-kühlkörpers ist über 60 °C.	Warten bis die Temperatur unter den Schwellenwert gesunken ist. Die Pumpe durch zweimalige Betätigung der START-Taste neustarten.

2 Gebrauchsanleitung

Fehlermeldungen

MELDUNG	BESCHREIBUNG	BEHEBUNG
TOO HIGH LOAD	Der von der Pumpe abgenommene Strom ist zu stark.	Sicherstellen, daß der Pumpenrotor ungehindert drehen kann. Die Pumpe durch zweimalige Betätigung der START-Taste neustarten.
SHORT CIRCUIT	Es gibt einen Kurzschluss an dem Pumpenanschluss.	Prüfen Sie die Anschlüsse und Kurzschlüsse zwischen Pumpe und Controller. Die Pumpe durch zweimalige Betätigung der START-Taste neustarten.
SYSTEM OVERRIDE	Die Pumpe wurde durch ein von einem entfernten Kontakt kommendes Notsignal gestoppt.	Das Netzkabel des Controllers ausstecken und die Störungsursache beheben. Das Netzkabel wieder anschließen und die Pumpe durch zweimalige Betätigung der START-Taste neustarten.
OVERVOLTAGE	Der Kreislauf der Controllerstromversorgung ist fehlerhaft oder der Controller empfängt eine unerwartete übermäßige Spannung.	Die Pumpe durch zweimalige Betätigung der START-Taste neustarten. Erscheint die Meldung wieder sollte der Agilent-Wartungs-dienst gerufen werden.
POWER FAIL	Fehler im Stromversorgungsabschnitt.	Agilent für Wartung kontaktieren.

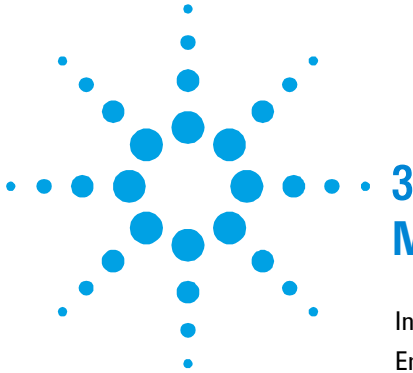

3 Mode d'emploi

Indications générales	40
Emmagasinage	41
Préparation pour l'installation	42
Installation	43
Utilisation	44
Commandes, Indicateurs et Connecteurs	45
Description du Tableau avant	45
Procédures d'utilisation	47
Allumage du Contrôleur	47
Mise en marche de la Pompe	47
Arrêt de la Pompe	47
Entretien	47
Mise au rebut	48
Messages d'erreur	48

Traduction de la mode d'emploi originale



Indications générales

Cet appareillage a été conçu en vue d'une utilisation professionnelle. Il est conseillé à l'utilisateur de lire attentivement cette notice d'instructions ainsi que toute autre indication supplémentaire fournie par Agilent, avant l'utilisation de l'appareil. Agilent décline par conséquent toute responsabilité en cas d'observation totale ou partielle des instructions données, d'utilisation incorrecte de la part d'un personnel non formé, d'opérations non autorisées ou d'un emploi contraire aux réglementations nationales spécifiques. Les contrôleurs de la série TwisTorr 84 FS AG Rack sont des convertisseurs de fréquence, contrôlés par un microprocesseur, réalisés avec des éléments à l'état solide et ayant des capacités d'autodiagnostic et d'autoprotection.

Caractéristiques du contrôleur:

- Caractère opérationnel de front /à distance / sériel
- Pilotage à 24 Vdc du ventilateur de refroidissement pompe
- Pilotage vanne de remise à l'air
- Lecture vitesse pompe suite au commande d'arrêt (lecture vitesse d'arrêt)
- Lecture de la pression
- Interface Profibus (facultatif)
- Attribution automatique tension d'entrée.

Les paragraphes suivants donnent toutes les indications nécessaires à garantir la sécurité de l'opérateur pendant l'utilisation de l'appareillage. Des renseignements plus détaillés se trouvent dans l'appendice "Technical Information".

Cette notice utilise les signes conventionnels suivants:

AVERTISSEMENT!



Les messages d'avertissement attirent l'attention de l'opérateur sur une procédure ou une manoeuvre spéciale qui, si elle n'est pas effectuée correctement, risque de provoquer de graves lésions.

ATTENTION!

Les messages d'attention apparaissent avant certaines procédures qui, si elles ne sont pas observées, pourraient endommager sérieusement l'appareillage.

NOTE

Les notes contiennent des renseignements importants, isolés du texte.

Emmagasinage

Pendant le transport et l'emmagasinage des contrôleurs, il faudra veiller à respecter les conditions environnementales suivantes:

- température: de - 20 °C à + 70 °C
- humidité relative: de 0% à 95 % (non condensante).

Préparation pour l'installation

Le contrôleur est fourni dans un emballage de protection spécial; si l'on constate des marques de dommages pouvant s'être produits pendant le transport, contacter aussitôt le bureau de vente local.

Pendant l'opération d'ouverture de l'emballage, veiller tout particulièrement à ne pas laisser tomber le contrôleur et à ne lui faire subir aucun choc. Ne pas jeter l'emballage dans la nature. Le matériel est entièrement recyclable et il est conforme aux directives CEE 85/399 en matière de protection de l'environnement.

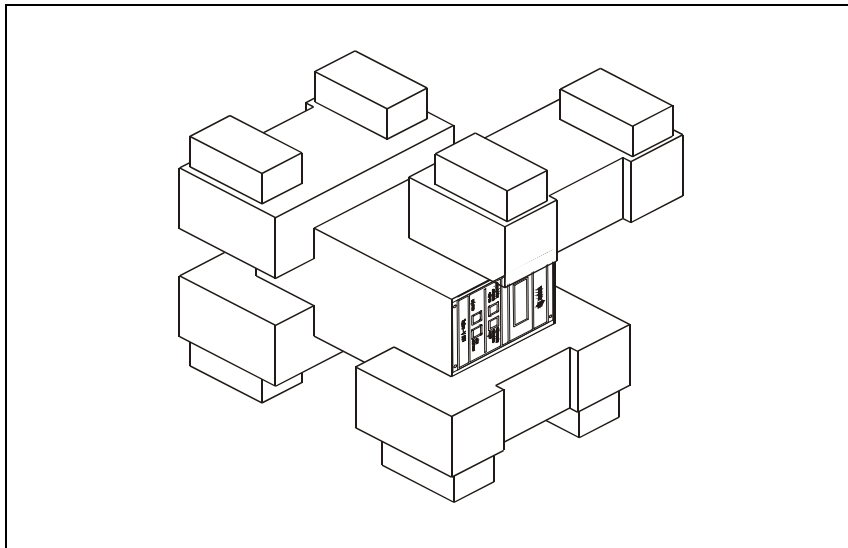

Figure 1 Emballage du contrôleur

Installation

AVERTISSEMENT!

Le contrôleur doit être alimenté au moyen d'un câble d'alimentation à trois fils (voir tableau des pièces que l'on peut commander) avec une fiche du type approuvé au niveau international en vue de la sécurité de l'utilisateur. Utiliser toujours ce câble d'alimentation et introduire la fiche dans une prise pourvue d'un branchement au sol approprié à la masse, afin d'éviter toute décharge électrique et de respecter les spécifications CE. A l'intérieur du contrôleur se développent de hautes tensions qui peuvent causer de graves dommages, voire la mort. Avant d'effectuer toute opération d'installation ou d'entretien du contrôleur, le débrancher de la prise d'alimentation.

NOTE

Le contrôleur peut être installé sur une table ou à l'intérieur d'un rack prévu à cet effet. Il est en tout cas nécessaire que l'air de refroidissement puisse circuler librement à l'intérieur de l'appareil. Ne pas installer et/ou utiliser le contrôleur dans des milieux exposés à des agents atmosphériques (pluie, gel, neige), à des poussières, à des gaz agressifs ainsi que dans des milieux explosifs ou à risque élevé d'incendie.

Pendant le fonctionnement, il est nécessaire de respecter les conditions environnementales suivantes:

- température: de +5 °C à +45 °C
- humidité relative: de 0 % à 95 % (non condensante).

Pour les autres connexions et pour l'installation des accessoires en option, voir la section "Technical Information".

Utilisation

Dans ce paragraphe, on indique les principales procédures opérationnelles. Pour tous autres détails et pour les procédures concernant des connexions ou des éléments en option, se reporter au paragraphe "Use" de l'appendice "Technical Information".

Avant d'utiliser le contrôleur, effectuer toutes les connexions électriques et pneumatiques et se référer à la notice de la pompe connectée.

AVERTISSEMENT!

Veillez-vous référer au manuel de la pompe spécifique pour l'utiliser en toute sécurité avant le démarrage.



NOTE

Laisser le connecteur de réenclenchement J1 connecté à sa barrette s'il n'est prévu aucune connexion extérieure. La pompe de pré-vide et la pompe TwisTorr peuvent être mises en marche simultanément.

Commandes, Indicateurs et Connecteurs

On présente ci-dessous le tableau de commande du Contrôleur ainsi que les tableaux d'interconnexion. Pour de plus amples détails, se reporter à la section "Technical Information".

Description du Tableau avant

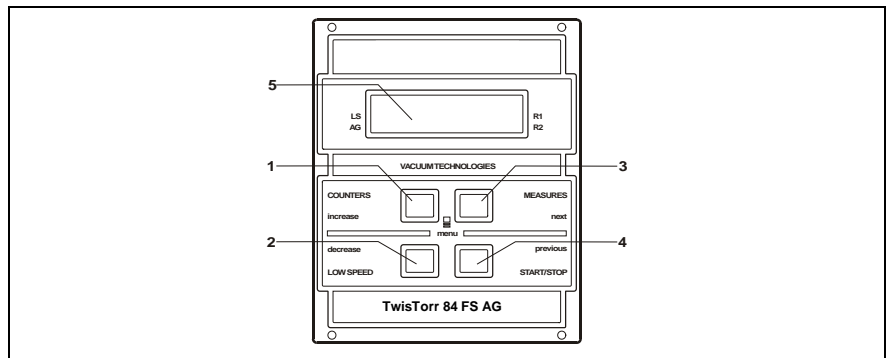

Figure 2 Tableau avant du Contrôleur TwisTorr 84 FS AG

1	Interrupteur rappelant sur l'afficheur les paramètres de cycle number, cycle time et pump life.
2	Interrupteur de sélection du mode LOW SPEED. Il n'est actif que lorsque le mode de commande est sélectionné depuis le tableau frontal. En le pressant une fois, la pompe tourne à vitesse "stand-by". En le pressant une deuxième fois, on désactive le mode LOW SPEED.
3	Interrupteur rappelant sur l'afficheur les paramètres "pump courant", "temperature", "puissance et vitesse de rotation". Il est toujours actif, indépendamment du mode de fonctionnement choisi. En pressant simultanément les interrupteurs 3 et 1 pendant 2 secondes au moins, on active un programme avec lequel il est possible de programmer certains paramètres opérationnels.
4	Interrupteur envoyant les commandes de START, STOP/RESET. Il n'est actif que lorsque le mode de commande est sélectionné depuis le tableau frontal. Une première pression de l'interrupteur active la phase de mise en marche; une deuxième pression provoque l'arrêt de la pompe. Si la pompe s'est arrêtée automatiquement à cause d'une panne, il faut presser cet interrupteur une première fois pour effectuer la mise à zéro du contrôleur et une deuxième fois pour remettre la pompe en marche.
5	Ecran alphanumérique à cristaux liquides: matrice de points, 2 lignes x 16 caractères.

3 Mode d'emploi

Utilisation

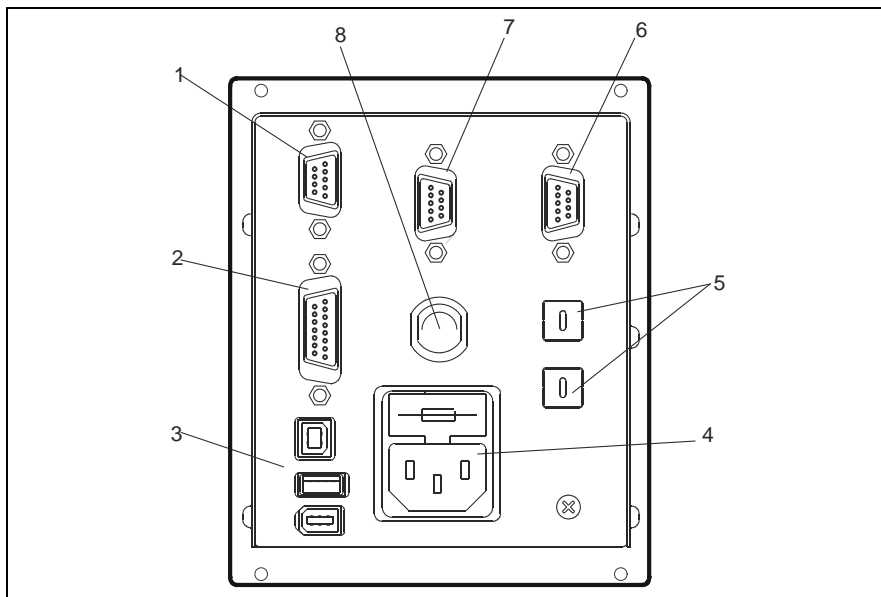

Figure 3 Tableau arrière du Contrôleur TwisTorr 84 FS AG

1	Connecteur d'entrée des signaux logiques (le connecteur d'enclenchement est doté de la barrette de réenclenchement spéciale).
2	Connecteur signaux logiques en sortie et monitoring fréquence pompe plus sortie analogique programmables.
3	Connecteur de sortie alimentation (24 Vdc pour le ventilateur de refroidissement pompe, vanne de remise à l'air et jauge).
4	Module d'entrée alimentation contrôleur qui comprend les fusibles, la prise d'alimentation et le filtre ENC.
5	Interrupteur à rotation pour établir l'adresse du Profibus (facultatif).
6	Profibus (facultatif).
7	Connecteur sériel pour contrôle à distance
8	Cable pour la pompe (5 m de longueur).

Procédures d'utilisation

Allumage du Contrôleur

Pour allumer le contrôleur, il suffit d'introduire le câble d'alimentation dans la prise du réseau

Mise en marche de la Pompe

Pour démarrer la pompe, confirmez l'entrée de verrouillage (broches de court-circuit 3÷8 sur P1) et appuyez sur le bouton-poussoir START en façade du régulateur.

Arrêt de la Pompe

Pour arrêter la pompe, presser l'interrupteur STOP du tableau avant.

Entretien

Les contrôleurs de la série TwisTorr 84 FS AG Rack n'exigent aucun entretien. Toute opération doit être effectuée par un personnel agréé.

En cas de panne, il est possible de s'adresser au Service de réparation Agilent ou bien au "Agilent advance exchange service" qui permet d'obtenir un contrôleur régénéré à la place du contrôleur défectueux.

AVERTISSEMENT!

Avant d'effectuer toute opération sur le contrôleur, débrancher le câble d'alimentation.

Si le régulateur doit être détruit, il sera éliminé conformément aux normes nationales spécifiques.

Mise au rebut

Signification du logo "WEEE" figurant sur les étiquettes. Le symbole ci-dessous est appliqué conformément à la directive CE nommée "WEEE". Ce symbole (**unique-ment valide pour les pays de la Communauté euro-péenne**) indique que le produit sur lequel il est appliqué NE doit PAS être mis au rebut avec les ordures ménagères ou les déchets industriels ordinaires, mais passer par un système de collecte sélective. Après avoir vérifié les termes et conditions du contrat de vente, l'utilisateur final est donc prié de contacter le fournisseur du dispositif, maison mère ou revendeur, pour mettre en œuvre le processus de collecte et mise au rebut.



Pour en savoir plus, consulter :

<http://www.agilent.com/environment/product/index.shtml>

Messages d'erreur

Le régulateur diagnostiquera lui-même certaines causes d'erreur et affichera les messages suivants :

Tab. 1

MESSAGE	DESCRIPTION	INTERVENTION
CHECK CONNECTION TO PUMP	Dysfonctionnement de la connexion entre la pompe et le contrôleur. Ou bien La pompe a une température inférieure à 0 °C.	S'assurer que le câble de connexion entre la pompe et le contrôleur est bien fixé aux deux extrémités et qu'il n'est pas coupé. Presser deux fois l'interrupteur START pour réactiver la pompe.
WAITING INTERLOCK	Le signal d'interlock situé sur le connecteur P1 est actif à cause de la coupure du court-circuit entre le pin 3 et le pin 8 du connecteur J1 ou à cause de l'ouverture du signal d'interlock extérieur.	Connectez le pin 3 au 8 du connecteur P1 ou fermer le signal d'interlock extérieur.
PUMP OVERTEMP.	La température du palier supérieur ou de la a dépassé 60 °C.	Attendre que la température retourne au-dessous du seuil. Presser deux fois l'interrupteur START pour remettre la pompe en marche.
CONTROLLER OVERTEMP.	La température du contrôleur a dépassé 70 °C. Ou bien La température du radiateur du contrôleur est supérieure à 60 °C.	Attendre que la température retourne au-dessous du seuil. Presser deux fois l'interrupteur START pour remettre la pompe en marche.

3 Mode d'emploi

Messages d'erreur

MESSAGE	DESCRIPTION	INTERVENTION
TOO HIGH LOAD	Le courant consommé par la pompe est trop élevé.	S'assurer que le rotor de la pompe a la possibilité de tourner librement. Presser deux fois l'interrupteur START pour remettre la pompe en marche.
SHORT CIRCUIT	Un court-circuit est présent sur le connecteur de la pompe.	Vérifiez les raccords et les courts-circuits entre la pompe et le régulateur. Presser deux fois l'interrupteur START pour remettre la pompe en marche.
SYSTEM OVERRIDE	La pompe a été arrêtée par un signal d'alerte provenant d'un contact éloigné.	Débrancher le câble d'alimentation du contrôleur et corriger la cause de l'alerte. Reconnecter le câble d'alimentation et presser deux fois l'interrupteur START pour remettre la pompe en marche.
OVERVOLTAGE	Le circuit d'alimentation du régulateur est défectueux ou le régulateur a reçu une tension excessive inattendue.	Presser deux fois l'interrupteur START pour remettre la pompe en marche. Si le message se présente à nouveau, s'adresser à Agilent pour l'entretien.
POWER FAIL	Panne dans la zone d'alimentation.	Dirigir-se à Agilent pour Maintenance.



4

Manual de instrucciones

Información general	52
Almacenamiento	53
Preparación para la instalación	54
Instalación	55
Uso	56
Mandos, Indicadores y Conectores	57
Descripción del panel frontal	57
Procedimientos de uso	59
Encendido del controler	59
Puesta en marcha de la Bomba	59
Parada de la Bomba	59
Mantenimiento	59
Eliminación	60
Mensajes de error	60

Traducción de las instrucciones originales



Información general

Este equipo se ha concebido para un uso profesional. El usuario deberá leer atentamente el presente manual de instrucciones y cualquier otra información suplementaria facilitada por Agilent antes de utilizar el equipo. Agilent se considera libre de cualquier responsabilidad debida al incumplimiento total o parcial de las instrucciones, al uso poco apropiado por parte de personal sin formación, a las operaciones no autorizadas o al uso que no cumpla con las normas nacionales específicas. Los controlers de la serie TwisTorr 84 FS AG Rack son convertidores de frecuencia, controlados por un microprocesador, realizados con componentes en estado sólido y con capacidad de autodiagnosis y autoprotección.

Características del controler:

- Operatividad frontal / remoto / serial
- Pilotaje de 24 Vdc del ventilador de refrigeración bomba
- Pilotaje vent valve
- Lectura velocidad bomba después de activación mando de parada (lectura velocidad de parada)
- Lectura de la presión
- Interfaz Profibus (opcional)
- Configuración automática tensión de entrada.

En los apartados siguientes se facilita toda la información necesaria para garantizar la seguridad del operador durante el uso del equipo. Una información más detallada se facilita en el Suplemento "Technical Information".

Este manual utiliza los símbolos convencionales siguientes:

¡ADVERTENCIA!



Los mensajes de advertencia atraen la atención del operador sobre un procedimiento o una operación específica que, al no realizarse correctamente, podría provocar graves lesiones personales.

¡ATENCIÓN!

Los mensajes de atención se visualizan antes de procedimientos que, al no respetarse, podrían provocar daños al equipo.

NOTA

Las notas contienen información importante extraída del texto.

Almacenamiento

Durante el transporte y el almacenamiento de los controlers se deberá cumplir con las condiciones ambientales siguientes:

- temperatura: de -20 °C a +70 °C
- humedad relativa: 0 – 95 % (no condensadora)

Preparación para la instalación

El controler se suministra en un embalaje de protección especial; si se observan señales de daños, que podrían haberse producido durante el transporte, ponerse en contacto con la oficina de venta más cercana.

Durante la operación de desembalaje, prestar una atención especial a no dejar caer el controler y evitarle golpes. No dispersar el embalaje en el medio ambiente. El material es totalmente reciclable y cumple con la directiva CEE 85/399 para la preservación del medio ambiente.



Figura 1 Embalaje del controlador

Instalación

¡ADVERTENCIA!

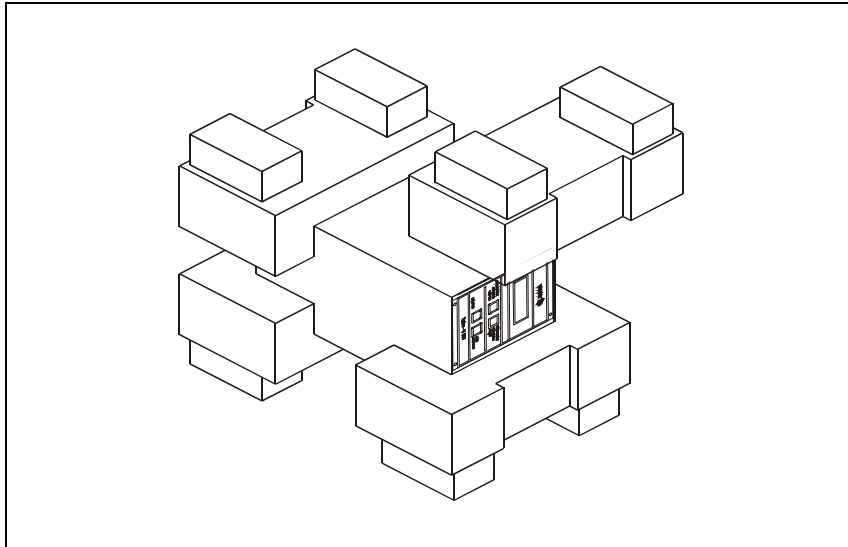

El controler debe ser alimentado mediante un cable de tres hilos (ver tabla de los componentes que pueden ser ordenados) con una clavija del tipo aprobado a nivel internacional con la finalidad de respetar las normas correspondientes a la seguridad del usuario. Utilizar siempre este cable de alimentación e introducir la clavija en un enchufe con una conexión de masa adecuada para evitar descargas eléctricas, y respetar las especificaciones CE. Dentro del controler se desarrollan altas tensiones que pueden causar graves daños o la muerte. Antes de efectuar cualquier operación de instalación o mantenimiento del controler desconectarlo del enchufe de alimentación.

NOTA

El controler puede instalarse en una mesa o dentro de un rack específico. En cualquier caso, es necesario que el aire de refrigeración pueda circular libremente alrededor del aparato. No instalar y/o utilizar el controler en ambientes expuestos a agentes atmosféricos (lluvia, hielo y nieve), polvos, gases agresivos, en ambientes explosivos o con alto riesgo de incendio.

Durante el funcionamiento es necesario que se respeten las condiciones ambientales siguientes:

- temperatura: de +5 °C a +45 °C
- humedad relativa: 0 – 95 % (no condensadora).

Para otras conexiones y la instalación de los accesorios opcionales, véase la sección “Technical Information”.

4 Manual de instrucciones

Uso

Uso

En este apartado se citan los procedimientos operativos principales. Para más detalles y para procedimientos que impliquen conexiones u opcionales especiales, les remitimos al apartado “Use” del anexo “Technical Informations”.

Antes de usar el controler efectuar todas las conexiones eléctricas y neumáticas y consultar el manual de la bomba conectada.

¡ADVERTENCIA!



Antes de arrancar la bomba consulte el correspondiente manual de instrucciones de la misma para operar de forma segura.

NOTA

El conector de cierre J1 ha de dejarse conectado con su conector puente si no se efectúa ninguna conexión exterior. La bomba pre-vacío y la bomba TwisTorr pueden encenderse simultáneamente.

Mandos, Indicadores y Conectores

A continuación se ilustran el panel de mando del controler y los paneles de interconexión. Para más detalles consultar la sección “Technical Information”.

Descripción del panel frontal



Figura 2 Panel frontal del Controller TwisTorr 84 FS AG

1	Pulsador para que aparezcan en el display los parámetros cycle number, cycle time y pump life.
2	Pulsador para la selección del modo LOW SPEED. Está activado sólo cuando está seleccionado el modo de mando del panel frontal. Apertando una vez, la bomba gira a velocidad “stand-by”. Apertándolo una vez más se desactiva el modo LOW SPEED.
3	Pulsador para que aparezcan en el display los parámetros “pump current”, “pump temperature”, “pump power” y “rotational speed”. Está siempre activado independientemente del modo de funcionamiento elegido. Apertando juntos los pulsadores 3 y 1 durante 2 segundos por lo menos, se activa un programa con el cual se pueden programar algunos parámetros operativos.
4	Pulsador para enviar los mandos de START, STOP/RESET. Está activo sólo cuando se selecciona el modo de mando del panel frontal. Apertándolo una vez se activa la fase de puesta en marcha; apertándolo otra vez se para la bomba. Si la bomba se ha parado automáticamente a causa de una avería, hay que apertar este pulsador primero una vez para efectuar el reset del controler y la segunda vez para volver a poner en marcha la bomba.
5	Display alfanumérico de cristales líquidos: matriz de puntos, 2 líneas x 16 caracteres.

4 Manual de instrucciones

Uso

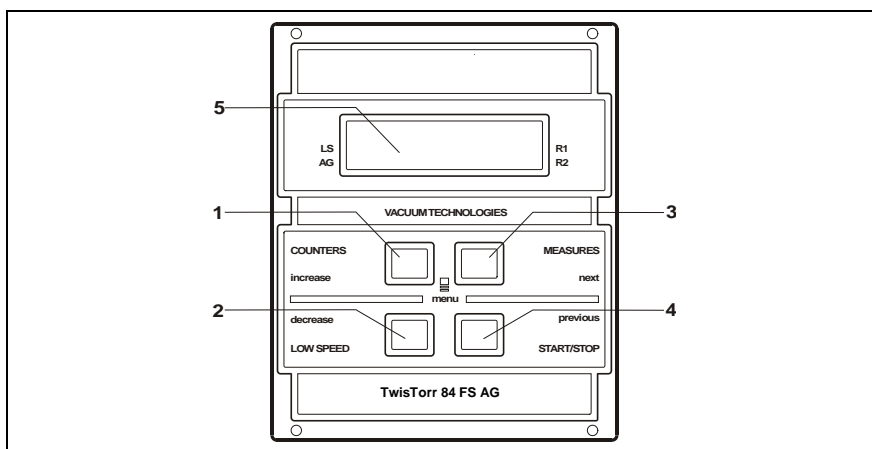

Figura 3 Panel trasero del controlador TwisTorr 84 FS AG

1	Conector de entrada de las señales lógicas (el conector de acoplamiento se suministra con el conector puente específico de cierre).
2	Conector de salida de señales lógicas y monitoreo de frecuencia de la bomba y salida analógica programable.
3	Conector de salida de alimentación (24 Vdc para el ventilador de refrigeración de la bomba, el vlvulo y el manómetro).
4	Módulo de entrada de alimentación con fusibles, toma de alimentación y filtro ENC.
5	Conmutador de rotación para configurar la dirección del Profibus (opcional).
6	Conector Profibus (opcional).
7	Conector serial para control remoto.
8	Cable de la bomba (5 m de largo).

Procedimientos de uso

Encendido del controler

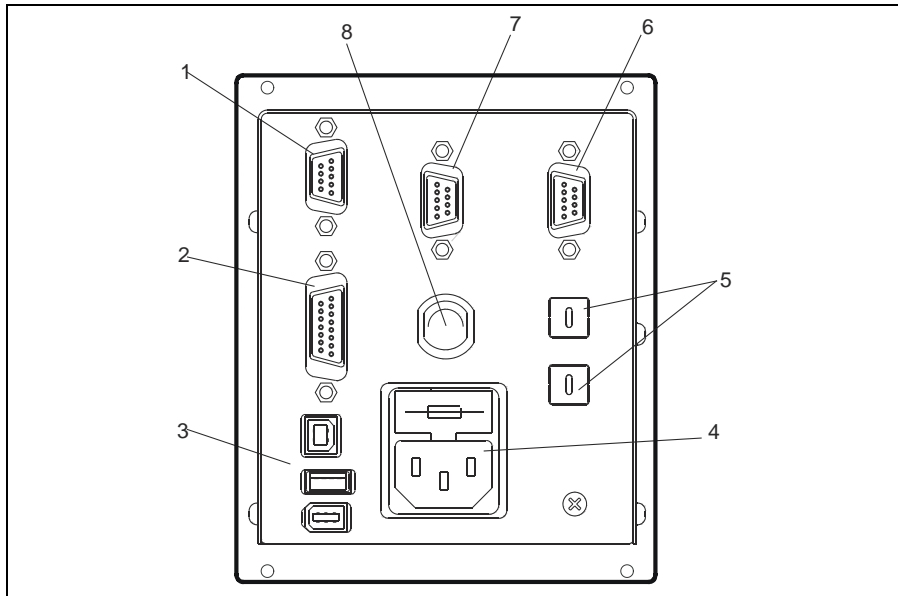
Para encender el controler es suficiente introducir el cable de alimentación en la toma de red.

Puesta en marcha de la Bomba

Para iniciar la bomba, confirme la entrada de enclavamiento (pasadores de cortocircuito 3÷8 en P1) y presione el botón START en el panel delantero del mando.

Parada de la Bomba

Para detener la bomba hay que apretar el pulsador STOP del panel frontal.

Mantenimiento

Los controlers de la serie TwisTorr 84 FS AG Rack no necesitan ningún mantenimiento. Cualquier operación ha de ser efectuada por personal autorizado. En caso de avería es posible utilizar el servicio de reparación Agilent o del “Agilent advance exchange service”, que permite obtener un controler regenerado en vez del averiado.

¡ADVERTENCIA!



Antes de efectuar cualquier operación en el controler desenchufar el cable de alimentación.

Si tiene que desechar un mando, hágalo siguiendo las normas nacionales específicas.

Eliminación

Significado del logotipo "WEEE" presente en las etiquetas. El símbolo que se indica a continuación, es aplicado en observancia de la directiva CE denominada "WEEE". Este símbolo (**válido sólo para los países miembros de la Comunidad Europea**) indica que el producto sobre el cual ha sido aplicado, NO debe ser eliminado junto con los residuos comunes sean éstos domésticos o industriales, y que, por el contrario, deberá ser sometido a un procedimiento de recogida diferenciada. Por lo tanto, se invita al usuario final, a ponerse en contacto con el proveedor del dispositivo, tanto si éste es la casa fabricante o un distribuidor, para poder proveer a la recogida y eliminación del producto, después de haber efectuado una verificación de los términos y condiciones contractuales de venta.



Para obtener más información, consulte:

<http://www.agilent.com/environment/product/index.shtml>

Mensajes de error

El controlador autodiagnosticará algunas causas de errores y mostrará los siguientes mensajes:

Tab. 1

MENSAJE	DESCRIPCIÓN	ACCIÓN CORRECTIVA
CHECK CONNECTION TO PUMP	Mal funcionamiento en la conexión entre la bomba y el Controler. O bien La bomba tiene una temperatura inferior a 0 °C.	Comprobar que el cable de conexión entra en la bomba y el controler está bien fijado por ambos extremos y no está interrumpido. Apretar dos veces el pulsador START para volver a poner en marcha la bomba.
WAITING INTERLOCK	Está activa la señal de interlock presente en el conector P1 a causa de la interrupción del cortocircuito entre el pin 3 y el pin 8 del conector J1, o a causa de la apertura de la señal de interlock externo.	Conecte el pin 3 al pin 8 del conector P1 o cierre la señal de enclavamiento externa.
PUMP OVERTEMP.	La temperatura del rodamiento superior o de la bomba ha superado los 60 °C.	Esperar a que la temperatura vuelva por debajo del umbral. Apretar dos veces el pulsador START para volver a poner en marcha la bomba.
CONTROLLER OVERTEMP.	La temperatura del controler ha superado los 70 °C. O bien La temperatura del radiador del controler es superior a 60 °C.	Esperar a que la temperatura vuelva por debajo del umbral. Apretar dos veces el pulsador START para volver a poner en marcha la bomba.

4 Manual de instrucciones

Mensajes de error

MENSAJE	DESCRIPCIÓN	ACCIÓN CORRECTIVA
TOO HIGH LOAD	La corriente derivada de la bomba es demasiado alta.	Comprobar que el rotor de la bomba tiene la posibilidad de girar libremente. Apretar dos veces el pulsador START para volver a poner en marcha la bomba.
SHORT CIRCUIT	Hay un cortocircuito en el conector de la bomba.	Compruebe las conexiones y cortocircuitos entre la bomba y el mando. Apretar dos veces el pulsador START para volver a poner en marcha la bomba.
SYSTEM OVERRIDE	La bomba ha sido parada por una señal de emergencia procedente de un contacto remoto.	Desenchufar el cable de alimentación del controler y corregir la causa de la emergencia. Volver a conectar el cable de alimentación y apretar dos veces el pulsador START para volver a poner en marcha la bomba.
OVERVOLTAGE	Los circuitos de alimentación del mando están dañados o el mando ha recibido un voltaje excesivo inesperado.	Apertar dos veces el pulsador START para volver a poner en marcha la bomba. Si el mensaje se vuelve a presentar dirigirse a Agilent para el mantenimiento.
POWER FAIL	Fallo en la sección de alimentación.	Ponerse en contacto con Agilent para el Mantenimiento.



5 Manual de Instruções

Informações gerais	64
Armazenagem	65
Preparação para a instalação	66
Instalação	67
Utilização	68
Comandos, Indicadores e Conectores	69
Descrição painel frontal	69
Procedimentos de uso	71
Acendimento do Controller	71
Activação da bomba	71
Paragem da bomba	71
Manutenção	71
Eliminação	72
Mensagens de erro	73

Tradução das instruções originais



Informações gerais

Esta aparelhagem destina-se ao uso profissional. O utilizador deve ler atentamente o presente manual de instruções e todas as informações adicionais fornecidas pela Agilent antes de utilizar a aparelhagem. A Agilent não se responsabiliza pela inobservância total ou parcial das instruções, pelo uso indevido por parte de pessoas não treinadas, por operações não autorizadas ou pelo uso contrário às normas nacionais específicas.

Os controllers da série TwisTorr 84 FS AG Rack são conversores de frequência, controlados por um microprocessador, realizados com componentes em estado sólido e com capacidade de autodiagnóstico e autoprotecção.

Características do controller:

- Operatividade frontal / remota / serial
- Pilotagem em 24 Vdc da ventoinha de resfriamento bomba
- Pilotagem vent valve
- Leitura velocidade bomba seguindo ao comando de paragem (leitura velocidade de paragem)
- Leitura da pressão
- Interface Profibus (opcional)
- Impostação automática tensão de entrada.

Nos parágrafos seguintes estão descritas todas as informações necessárias para garantir a segurança do operador durante o uso da aparelhagem. Informações pormenorizadas são fornecidas no apêndice "Technical Information".

Este manual utiliza as seguintes convenções:

ATENÇÃO!



As mensagens de atenção chamam a atenção do operador para um procedimento ou uma prática específica que, se não efectuada correctamente, pode provocar graves lesões pessoais.

CUIDADO!

As mensagens de cuidado são visualizadas antes de procedimentos que, se não observados, podem causar danos à aparelhagem.

NOTA

As notas contêm informações importantes destacadas do texto.

Armazenagem

Durante o transporte e a armazenagem dos controllers, devem ser satisfeitas as seguintes condições ambientais:

- temperatura: de -20 °C a + 70 °C
- humidade relativa: 0 – 95 % (não condensante)

Preparação para a instalação

O controller é fornecido numa embalagem protectora especial; se apresentar sinais de danos, que poderiam verificar-se durante o transporte, entrar em contacto com o escritório de vendas local.

Durante a retirada da embalagem, tomar muito cuidado para não deixar cair o controller e para não submetê-lo a choques. Não depositar a embalagem no meio ambiente. O material é completamente reciclável e responde à directriz CEE 85/399 para a protecção do meio ambiente.



Figura 1 Embalagem do controller

Instalação

ATENÇÃO!

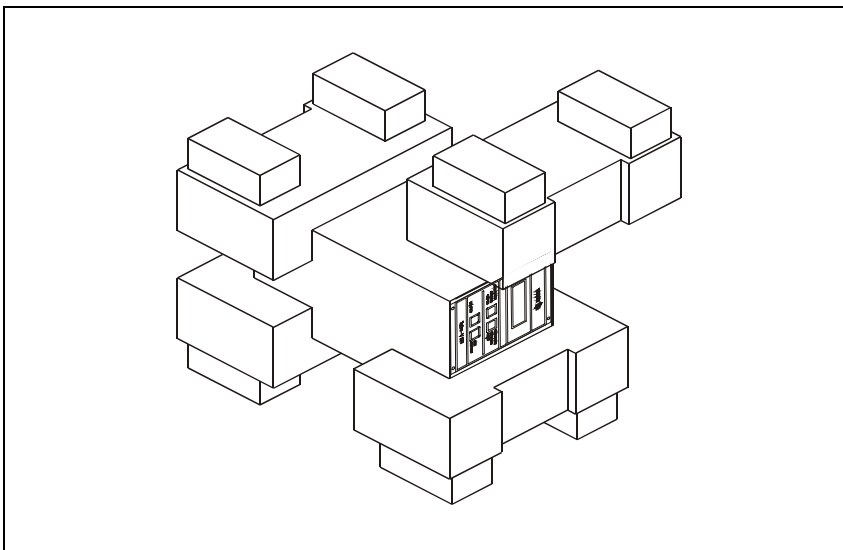

O controller deve ser alimentado mediante um cabo de alimentação de três fios(ver tabela das partes ordenáveis) com uma tomada de tipo aprovado a nível internacional com a finalidade de segurança do usuário. Utilizar sempre este cabo de alimentação e inserir a tomada com uma adequada ligação de terra para evitar descargas eléctricas e para respeitar as normativas CE. No interior do controller desenvolvem-se altas tensões que podem provocar graves danos ou a morte. Antes de efectuar qualquer operação de instalação ou manutenção do controller, desligar a tomada de alimentação.

NOTA

O controller pode ser instalado numa mesa ou no interior de um rack específico. Em todo caso, é necessário que o ar de refrigeração possa circular livremente ao redor da aparelhagem. Não instalar e/ou utilizar o controller em ambientes expostos a agentes atmosféricos (chuva, gelo, neve), poeiras, gases agressivos ou em ambientes com perigo de explosão ou com elevado risco de incêndio.

Durante o funcionamento é necessário que sejam respeitadas as seguintes condições ambientais:

- temperatura: de +5 °C a +45 °C
- humidade relativa: 0 – 95 % (não condensante).

Para as outras ligações e a instalação dos acessórios opcionais, ver a secção "Technical Information".

Utilização

Neste parágrafo são descritos os principais procedimentos operativos. Para maiores detalhes e para procedimentos que envolvem ligações ou peças opcionais, consultar o parágrafo "Use" do apêndice "Technical Information".

Antes de usar o controller, efectuar todas as ligações eléctricas e pneumáticas e consultar o manual da bomba ligada.

ATENÇÃO!



Consulte o respectivo manual da bomba para operá-la de forma segura antes de começar.

NOTA

O conector de fecho J1 deve permanecer ligado à sua ponte se não é efectuada nenhuma ligação externa. A bomba de pré-vácuo e a bomba TwisTorr podem ser ligadas simultaneamente.

Comandos, Indicadores e Conectores

A seguir, estão ilustrados o painel de comando do Controller e os painéis de interconexão. Para maiores detalhes, consultar a secção "Technical Information".

Descrição painel frontal



Figura 2 Painel frontal do Controller TwisTorr 84 FS AG

1	Botão para evidenciar no display os parâmetros, cycle number, cycle time e pump life.
2	Botão para a seleção do modo LOW SPEED. É activo somente quando for seleccionado o modo de comando do painel frontal. Apertando uma vez, a bomba roda com velocidade "stand-by".. Apertando-o novamente desactiva-se o modo LOW SPEED.
3	Botão para evidenciar no display os parâmetros "pump current", "pump temperature", "pump power" e "rotational speed". É sempre activo independentemente do modo de funcionamento escolhido. Apertando os botões 3 e 1 em conjunto pelo menos 2 segundos é activado um programa com o qual é possível programar alguns parâmetros operativos.
4	Botão para enviar os comandos de START, STOP/RESET. É activo somente quando for seleccionado o modo de comando do painel frontal. Apertando-o uma vez activa-se a fase de arranque; apertando-o novamente pára a bomba. Se a bomba parou automaticamente por causa de uma avaria, ocorre apertar este botão uma primeira vez para executar o reset do controller e uma segunda vez para reiniciar a bomba.
5	Display alfanumérico com cristais líquidos: matriz de pontos 2 linhas x 16 caracteres.

5 Manual de Instruções

Utilização

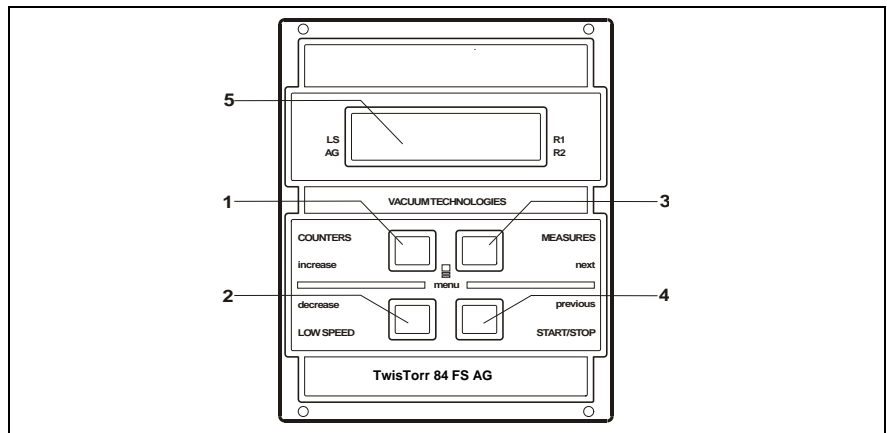

Figura 3 Painel posterior dos Controllers TwisTorr 84 FS AG

1	Conector de entrada dos sinais lógicos (o conector de acoplamento é fornecido com ponte específica de fecho).
2	Conector sinais lógicos na saída e monitoragem freqüência bomba mais saída analógica programável.
3	Conector de saída alimentação (24 Vdc para a ventoinha resfriamento bomba, vent valve e medidor de vácuo).
4	Modulo de entrada alimentação controller que compreende os fusíveis, a tomada de alimentação e o filtro ENC.
5	Switch em rotação para impostar o endereço do Profibus (opcional).
6	Profibus (opcional).
7	Conector serial para controle de remoto.
8	Cabo bomba (comprimento 5 m).

Procedimentos de uso

Acendimento do Controller

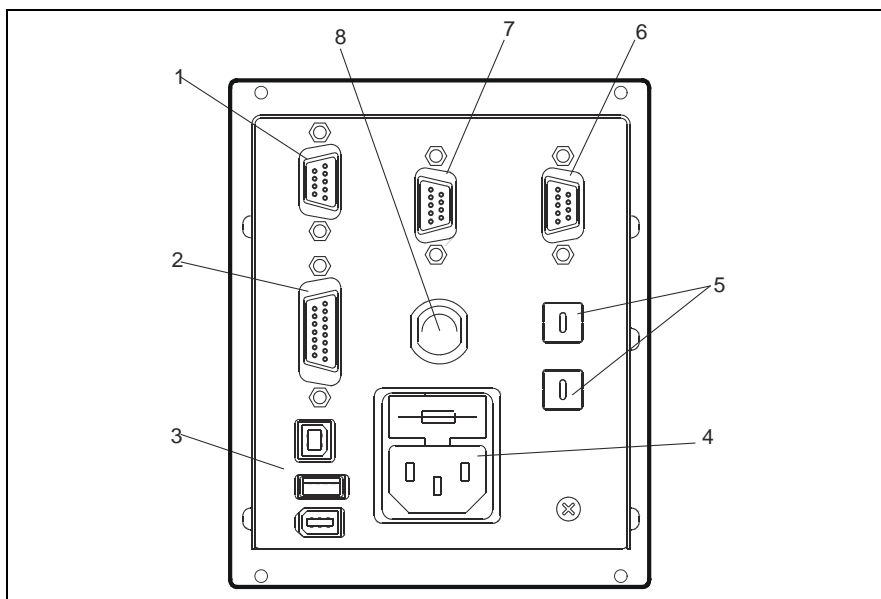
Para ligar o controller, é suficiente inserir o cabo de alimentação na tomada de rede.

Activação da bomba

Para ligar a bomba, confirmar a entrada de interbloqueio (pinos curto-circuito 3 ÷ 8 em P1) e pressione o botão START no painel frontal do controlador.

Paragem da bomba

Para parar a bomba, é necessário premer o botão STOP do painel frontal.

Manutenção

Os controllers da série TwisTorr 84 FS AG Rack não requerem qualquer manutenção. Todas as operações devem ser efectuadas por pessoal autorizado.

Em caso de defeito é possível utilizar o serviço de reparação Agilent ou o "Agilent advanced exchange service", que permite obter um controller regenerado que substitua o controller com defeito.

ATENÇÃO!

Antes de efectuar qualquer operação no controller, desligar o cabo de alimentação.

Se um controlador precisar de ser eliminado, deve ser descartado em conformidade com as normas nacionais específicas.

Eliminação

Significado do logótipo "WEEE" presente nos rótulos. O símbolo abaixo indicado é aplicado de acordo com a directiva CE denominada "WEEE". Este **símbolo (válido apenas para os países da Comunidade Europeia)** indica que o produto no qual está aplicado NÃO deve ser eliminado juntamente com os resíduos domésticos ou industriais comuns, mas deve ser dirigido a um sistema de recolha diferenciada. Portanto, convidamos o utilizador final a contactar o fornecedor do dispositivo, seja este o fabricante ou um revendedor, para encaminhar o processo de recolha e eliminação, após a oportuna verificação dos termos e condições do contrato de venda.



Para mais informações consulte:

<http://www.agilent.com/environment/product/index.shtml>

Mensagens de erro

O controlador irá auto-diagnosticar algumas causas de erro e irá exibir as seguintes mensagens:

Tab. 1

MENSAGEM	DESCRIÇÃO	ACÇÃO CORRECTIVA
CHECK CONNECTION TO PUMP	Mau funcionamento na ligação entre a bomba e o controller. Ou A bomba possui temperatura inferior a 0 °C.	Verificar se o cabo de ligação entre a bomba e o controller está bem fixado em ambas as extremidades e não está interrompido. Premer duas vezes o botão START para reactivar a bomba.
WAITING INTERLOCK	É activado o sinal de interlock existente no conector P1 devido à interrupção do curto circuito entre o pin 3 e o pin 8 do conector J1 ou devido à abertura do sinal de interlock externo.	Conecte o pino 3 ao pino 8 do conector P1, ou feche o sinal de interbloqueio externo.
PUMP OVERTEMP.	A temperatura do rolamento superior ou da bomba superou os 60 °C.	Aguardar até que a temperatura volte ao limite estabelecido. Premer duas vezes o botão START para reactivar a bomba.
CONTROLLER OVERTEMP.	A temperatura do controller superou os 70 °C. Ou A temperatura do radiador do controller é superior a 60 °C.	Aguardar até que a temperatura volte ao limite estabelecido. Premer duas vezes o botão START para reactivar a bomba.

5 Manual de Instruções

Mensagens de erro

MENSAGEM	DESCRIÇÃO	ACÇÃO CORRECTIVA
TOO HIGH LOAD	A corrente gerada pela bomba é demasiado alta.	Verificar se o rotor da bomba pode rodar livremente. Premer duas vezes o botão START para reactivar a bomba.
SHORT CIRCUIT	Um curto-circuito está presente no conector da bomba.	Verifique as conexões e curto-circuitos entre a bomba e o controlador. Premer duas vezes o botão START para reactivar a bomba.
SYSTEM OVERRIDE	A bomba parou por um sinal de emergência proveniente de um contacto remoto.	Remover o cabo de alimentação do controller e corrigir a causa da emergência. Ligar novamente o cabo de alimentação e premer duas vezes o botão START para reactivar a bomba.
OVERVOLTAGE	O circuito de alimentação do controlador está com defeito ou o Controlador recebeu uma tensão excessiva inesperada.	Premer duas vezes o botão START para reactivar a bomba. Se a mensagem se reapresentar, dirigir-se à Agilent para a manutenção.
POWER FAIL	Falha na seção da fonte de alimentação.	Dirigir-se a Agilent para Manutenção.



6 Bedrijfshandleiding

Algemene informatie	76
Opslag	77
Vorbereiding voor installatie	78
Installatie	79
Gebruik	80
Bedieningsorganen, Controlelampjes en Connectoren van	81
Beschrijving frontpaneel	81
Gebruiksprocedures	81
Inschakelen van de controller	83
Starten van de pomp	83
Stoppen van de pomp	83
Onderhoud	83
Afvalverwerking	84
Foutmeldingen	85

Vertaling van de originele instructies



Algemene informatie

Deze apparatuur is bestemd voor beroepsmatig gebruik. De gebruiker wordt verzocht aandachtig deze handleiding en alle overige door Agilent verstrekte informatie door te lezen alvorens het apparaat in gebruik te nemen. Agilent acht zich niet aansprakelijk voor de gevolgen van het niet of gedeeltelijk in acht nemen van de aanwijzingen, onoordeelkundig gebruik door niet hiervoor opgeleid personeel, reparaties waarvoor geen toestemming is verkregen of gebruik in strijd met de specifieke nationale wetgeving. De controllers van de TwisTorr 84 FS AG Rack serie zijn frequentieomzetter die gestuurd worden door een microprocessor, zijn gemaakt van halfgeleider-elementen en zijn in staat om zelfdiagnose en zelfbescherming uit te voeren.

Kenmerken van de controller:

- Bediening frontaal / op afstand / serieel
- Sturing met 24 Vdc van de koelventilator van de pomp
- Sturing vent valve
- Lezen snelheid pomp na stopcommando (lezen stopsnelheid)
- Lezen van de druk
- Interface Profibus (optie)
- Automatische instelling ingangsspanning.

In de volgende paragrafen is alle informatie vermeld om de veiligheid van de operator tijdens het gebruik van de apparatuur te verzekeren. Gedetailleerde informatie is te vinden in de bijlage "Technical information".

Deze handleiding hanteert de volgende symbolen:

WAARSCHUWING!



Bij dit symbool staat tekst die de aandacht van de operator vestigt op een speciale procedure of methode die, indien niet correct uitgevoerd, ernstig lichamelijk letsel kan veroorzaken.

VOORZICHTIG!

Bij dit symbool staat tekst met procedures die, indien niet opgevolgd, schade aan apparatuur kunnen veroorzaken

OPMERKING

De opmerkingen bevatten belangrijke informatie die uit de tekst is gelicht.

Opslag

Tijdens het transport en de opslag van de controllers moeten de volgende omgevingscondities aanwezig zijn:

- temperatuur: van -20 °C tot +70 °C
- relatieve vochtigheid: 0 – 95 % (niet condenserend)

Vorbereitung voor installatie

De controller wordt in een speciale beschermende verpakking geleverd; als er schade wordt geconstateerd die tijdens het transport veroorzaakt zou kunnen zijn, meteen contact opnemen met het plaatselijke verkoopkantoor.

Zorg er bij het uitpakken voor dat de controller niet kan vallen of stoten te verduren krijgt.

Laat de verpakking niet ergens buiten achter. Het verpakkingsmateriaal is volledig recyclebaar en voldoet aan de EEG milieuriichtlijn 85/399.

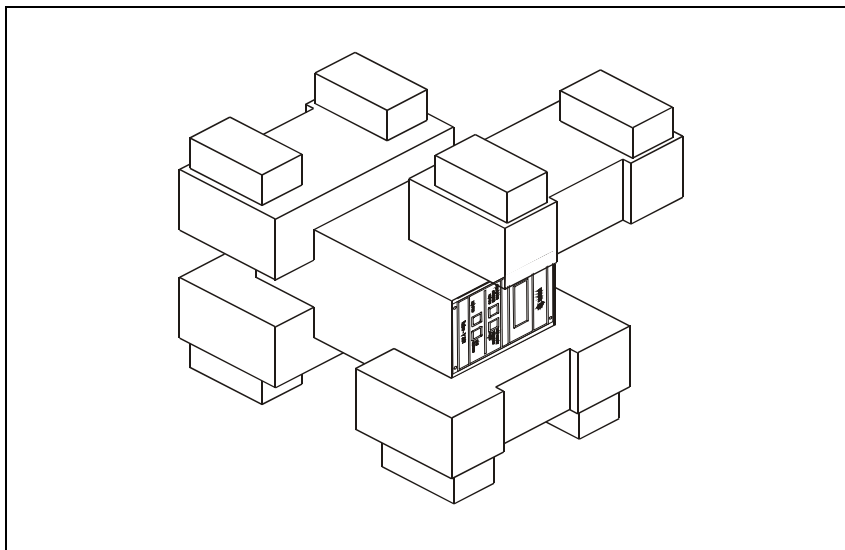

Figuur 1 Verpakking van de controller

Installatie

WAARSCHUWING!



De controller moet gevoed worden via een voedingskabel met drie draden (zie tabel met bestelbare onderdelen) met een stekker van het internationaal goedgekeurde type om de veiligheid van de gebruiker te waarborgen. Gebruik altijd deze voedingskabel en steek de stekker in een geaarde contactstop om elektrische ontladingen te voorkomen en aan de CE-specificaties te voldoen. In de controller ontwikkelen zich hoge spanningen die zware beschadigingen of de dood kunnen veroorzaken. Alvorens installatie- of onderhoudswerkzaamheden uit te voeren, de controller van de contactstop afkoppelen.

OPMERKING

De controller kan op een tafel of in een speciaal rack worden geïnstalleerd. In ieder geval moet de koellucht vrij rondom het apparaat kunnen circuleren. De controller mag niet geïnstalleerd en/of gebruikt worden in ruimten die blootgesteld zijn aan de weersomstandigheden (regen, vorst, sneeuw), stof, agressieve gassen, of in ruimten met explosiegevaar of zeer hoog brandgevaar.

Tijdens de werking moeten de volgende omgevingscondities aanwezig zijn:

- temperatuur: van +5 °C tot +45 °C
- relatieve vochtigheid: 0 – 95 % (niet condenserend).

Voor de overige aansluitingen en de installatie van de accessoires wordt verwezen naar het hoofdstuk "Technical Information".

Gebruik

In deze paragraaf worden de voornaamste bedieningswijzen uitgelegd. Voor meer informatie of procedures die aansluitingen of speciale opties betreffen wordt verwezen naar de paragraaf "Use" van de bijlage "Technical Informations". Breng, alvorens de controller in gebruik te nemen, alle elektrische en pneumatische aansluitingen tot stand en raadpleeg hiervoor de handleiding van de aan te sluiten pomp.

WAARSCHUWING!



Raadpleeg de betreffende handleiding van de pomp, voor een veilige bediening, voorafgaand aan het starten.

OPMERKING

De connector J1 moet met zijn jumper aangesloten blijven als geen externe aansluiting tot stand wordt gebracht. De pre-vacuümpomp en de TwisTorr pomp mogen beide gelijktijdig ingeschakeld zijn.

Bedieningsorganen, Controlelampjes en Connectoren van

Hieronder worden het frontpaneel en het achterpaneel van de controller geïllustreerd. Voor meer informatie wordt verwezen naar het hoofdstuk "Technical Information".

Beschrijving frontpaneel

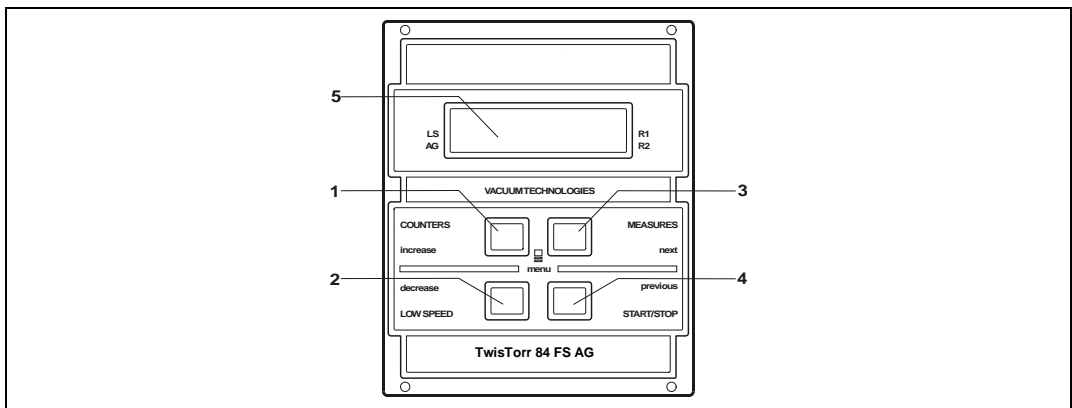

Figuur 2 Frontpaneel van de Controllers TwisTorr 84 FS AG

- | | |
|---|--|
| 1 | Drukknop voor weergave op het display van de parameters cycle number, cycle time en pump life. |
| 2 | Drukknop voor selectie van de bedrijfswijze LOW SPEED. Is alleen actief wanneer de bedrijfswijze op het frontpaneel wordt geselecteerd. Door de knop een maal in te drukken, draait de pomp met "stand-by" snelheid. Door de knop opnieuw in te drukken, wordt LOW SPEED geïnactiveerd. |
| 3 | Drukknop voor weergave op het display van de parameters "pump current", "pump temperature", "pump power" en "rotational speed". Is altijd actief, onafhankelijk van de gekozen bedrijfswijze. Door drukknoppen 3 en 1 gelijktijdig gedurende ten minste 2 seconden in te drukken, wordt een programma gestart waarmee enkele bedrijfsparameters kunnen worden geprogrammeerd. |
| 4 | Drukknop voor het zenden van de sturingen START, STOP/RESET. Is alleen actief wanneer de bedrijfswijze op het frontpaneel wordt geselecteerd. Door de knop een maal in te drukken wordt de startfase geactiveerd; door de knop opnieuw te bedienen wordt de pomp gestopt. Als de pomp automatisch is gestopt ten gevolge van een storing, moet deze knop een eerste maal worden bediend om de controller te resetten en een tweede maal om de pomp weer op te starten. |
| 5 | Alfanumeriek display met vloeibare kristallen (LCD): puntjespatroon, 2 lijnen x 16 karakters. |

6 Bedrijfshandleiding

Gebruik

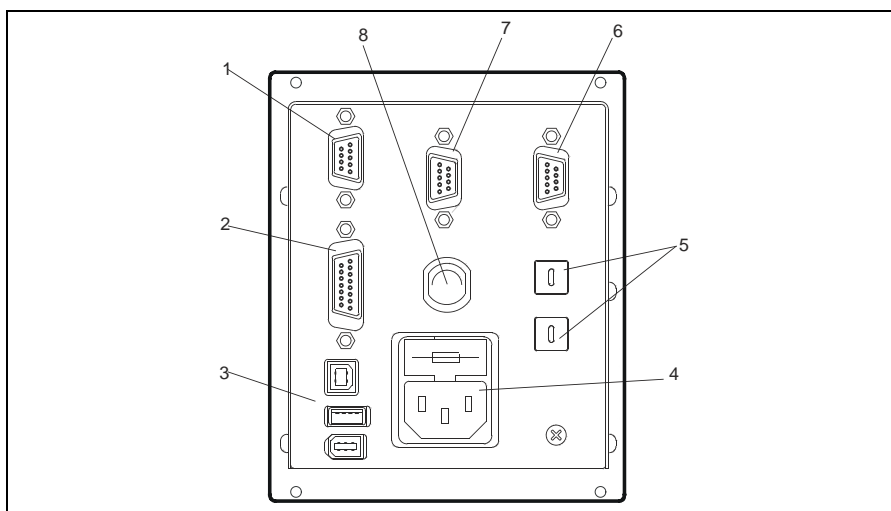

Figuur 3 Achterpaneel van de controllers TwisTorr 84 FS AG

1	Connector voor ingang logische signalen (de te koppelen connector wordt met de speciale sluitklem geleverd).
2	Connector voor uitgang logische signalen en frequentiecontrole pomp plus programmeerbare analogische uitgang.
3	Uitgangsaansluiting voeding (24 Vdc voor de koelventilator van de pomp, vent valve en manometer).
4	Ingangsmodule voeding controller die de zekeringen, het voedingscontact en het ENC-filter bevat.
5	Draaischakelaar om het adres van de Profibus in te stellen (optie).
6	Profibus (optie).
7	Seriële connector voor afstandsbesturing.
8	Kabel van de pomp (5 m lang)

Gebruiksprocedures

Inschakelen van de controller

Om de controller in te schakelen, de voedingskabel in de netcontactdoos inbrengen.

Starten van de pomp

Bevestig de verbinding (de pinnen 3÷8 op P1 kortsluitend) en druk op START op de controller op het frontpaneel als u de pomp wil starten.

Stoppen van de pomp

Voor het stoppen van de pomp de STOP knop op het frontpaneel bedienen.

Onderhoud

De controllers van de serie TwisTorr 84 FS AG Rack zijn onderhoudsvrij. Eventuele werkzaamheden moeten door bevoegd personeel worden uitgevoerd.

In geval van storing is het mogelijk om de reparatiedienst van Agilent of de "Agilent advanced exchange service" in te schakelen: zo krijgt men een ruilcontroller ter vervanging van de defecte controller.

WAARSCHUWING!

Alvorens werkzaamheden aan de controller uit te voeren, de voedingskabel afkoppelen.

Mocht de controller gesloopt worden, ga dan overeenkomstig de specifieke nationale wetgeving te werk.

Afvalverwerking

Betekenis van het logo "WEEE" op de etiketten. Het onderstaande symbool wordt aangebracht in overeenstemming met de EG-richtlijn "WEEE". Dit symbool (**alleen geldig voor de landen van de Europese Gemeenschap**) geeft aan dat het product waarop het is aangebracht, NIET mag worden afgevoerd samen met normaal huisvuil of industrieel afval, maar gescheiden moet worden ingezameld. De eindgebruiker wordt dus verzocht contact op te nemen met de leverancier van het apparaat, zij het de fabrikant of een wederverkoper, om het proces van gescheiden inzameling en verwerking in gang te zetten, na de van toepassing zijnde termen en voorwaarden van het verkoopcontract te hebben gecontroleerd.



Voor meer informatie wordt verwezen naar:
<http://www.agilent.com/environment/product/index.shtml>

Foutmeldingen

De controller zal enkele oorzaken van fouten zelf vaststellen en de volgende meldingen geven:

Tab. 1

BOODSCHAP	OMSCHRIJVING	REMEDIË
CHECK CONNECTION TO PUMP	Foutieve verbinding tussen pomp en controller. Of De pomp heeft een lagere temperatuur dan 0 °C.	Controleren of de verbindingskabel tussen pomp en controller aan beide uiteinden goed bevestigd is en geen onderbrekingen vertoont. Bedien twee maal de START-knop om de pomp weer op te starten.
WAITING INTERLOCK	Het interlock-sigitaal op connector P1 is actief wegens onderbreking van de kortsluiting tussen pin 3 en pin 8 van connector J1 of wegens het openen van het externe interlock-sigitaal.	Sluit pin 3 aan op pin 8 van de P1-connector, of sluit het externe verbindingssigitaal.
PUMP OVERTEMP.	De temperatuur van het bovenste pomplager bedraagt meer dan 60 °C.	Wacht tot de temperatuur weer onder de drempelwaarde is gezakt. Bedien twee maal de START-knop om de pomp weer op te starten.
CONTROLLER OVERTEMP.	De temperatuur van de controller bedraagt meer dan 70 °C. Of De temperatuur van de radiator van de controller bedraagt meer dan 60 °C.	Wacht tot de temperatuur weer onder de drempelwaarde is gezakt. Bedien twee maal de START-knop om de pomp weer op te starten.

6 Bedrijfshandleiding

Foutmeldingen

BOODSCHAP	OMSCHRIJVING	REMEDIE
TOO HIGH LOAD	De huidige trek door de pomp is te hoog.	Controleer of de pomprotor vrij kan draaien. Bedien twee maal de START-knop om de pomp weer op te starten.
SHORT CIRCUIT	Er is kortsluiting op de pompconnector.	Inspecteer de aansluitingen en of er kortsluitingen zijn geweest tussen de pomp en de controller. Bedien twee maal de START-knop om de pomp weer op te starten.
SYSTEM OVERRIDE	De pomp is stilgelegd door een noodsignaal afkomstig van een afstandscontact.	Koppel de voedingskabel van de controller af en elimineer de oorzaak van de noodstop. Sluit de voedingskabel weer aan en bedien twee maal de START-knop om de pomp weer op te starten.
OVERVOLTAGE	Het voedingscircuit van de controller is defect of de controller heeft een onverwacht hoog voltage ontvangen.	Bedien twee maal de START-knop om de pomp weer op te starten. Als de melding weer verschijnt zich voor onderhoud tot Agilent wenden.
POWER FAIL	Defect in de voeding.	Neem contact op met Agilent voor onderhoud.

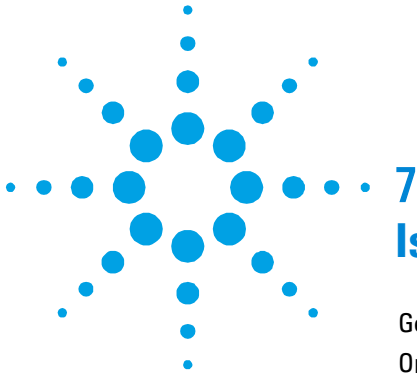

7 Instruktionsbog

Generel Information	88
Opbevaring	89
Forberedelser før installation	90
Installation	91
Anvendelse	92
Indikatorer og Kontakter på Styreenheden	93
Beskrivelse af frontpanel	93
Instruktion	95
Start af styreenheden	95
Start af pumpen	95
Stop af pumpen	95
Vedligeholdelse	95
Bortskaffelse	96
Fejlmeddelelser	97

Oversættelse af originalinstruktionerne



Generel Information

Dette materiel er beregnet til professionel anvendelse. Brugeren bør læse denne brugsanvisning og anden yderligere information fra Agilent, før udstyret anvendes. Agilent tager ikke ansvar for skader helt eller delvis som følge af tilsidesættelse af disse instruktioner, fejlagtig brug af personer uden tilstrækkelig kendskab, ukorrekt anvendelse af udstyret eller håndtering, der strider imod gældende lokale regler. Styreenhederne i TwisTorr 84 FS AG Rack serien er mikroprocessorstyrede frekvens-omformere, der består af komponenter med fast tilstand.

Styreenhed specifikationer:

- Frontal /fjern- /seriel styring
- 24 Vdc styring af pumpens blæser
- Vent valve styring
- Aflæsning af pumpens hastighed som følge af tryk på stop (aflæsning af stophastighed)
- Aflæsning af tryk
- Profibus brugerflade (ekstra)
- Automatisk indstilling af indgangsspændingen.

De følgende afsnit indeholder al information der behøves, for at garantere operatørens sikkerhed under anvendelsen. Detaljeret information findes i bilaget "Technical Information".

I brugsanvisningen anvendes følgende standard-rubrikker:

ADVARSEL!



Advarselsmeddelelserne informerer operatøren om, at en speciel procedure eller en vis type arbejde skal udføres præcist efter anvisningerne. I modsat fald er der risiko for svære personskader.

FORSIGTIG!

Denne advarselsmeddelelse vises før procedurer, der skal følges nøje for ikke at risikere maskinskader.

BEMÆRK

Dette gør opmærksom på vigtig information i teksten.

Opbevaring

Følgende krav til omgivelsesforholdene gælder ved transport og opbevaring af styreenheden:

- temperatur: fra -20 °C til +70 °C
- relativ luftfugtighed: 0 – 95 % (ikke kondenserende)

Forberedelser før installation

Styreenheden leveres i en speciel beskyttende emballage. Kontakt den lokale forhandler, hvis emballagen viser tegn på skader, der kan være opstået under transporten. Sørg for at styreenheden ikke tabes eller udsættes for stød ved udpakningen.

Smid ikke emballagen ud. Materialet kan genbruges 100 % og opfylder EU-direktiv 85/399 om miljøbeskyttelse.

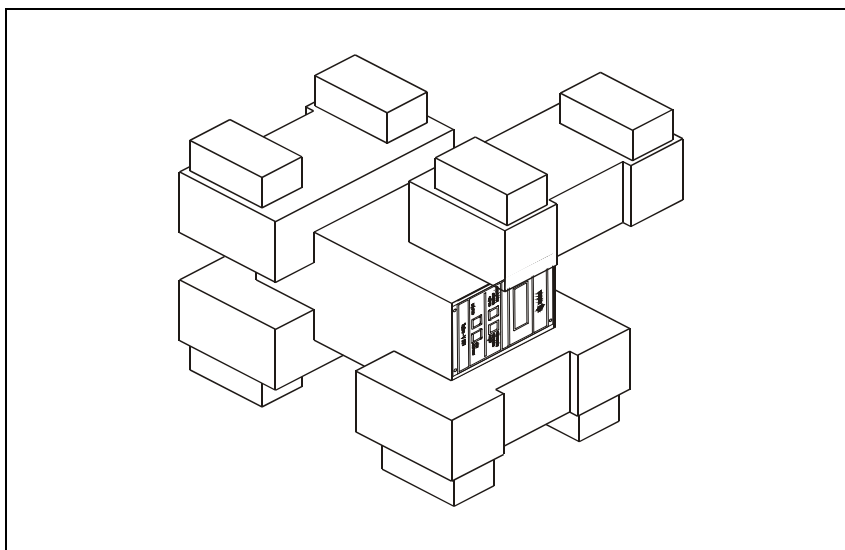

Figur 1 Styreenhedens emballage

Installation

ADVARSEL!



For at sikre brugersikkerhed skal styreenheden tilkobles et strømkabel med tre ledere (se reservedelslisten) og godkendt stik efter internationale standarder. Anvend udelukkende det medleverede strømkabel. I henhold til EU reglerne må stikket kun tilsluttes et vægudtag med fungerende jordtilslutning, for at undgå elektriske stød. Spænding frembragt i styreenheden kan nå høje værdier og forårsage stor skade og dødsfald. Frakobel altid strømkablet, inden der udføres installations- eller vedligeholdelsesarbejde på styreenheden.

BEMÆRK

Styreenheden kan installeres på et bord eller et velegnet stativ. I begge tilfælde skal der være plads nok til, at luft kan cirkulere frit omkring apparatet. Installér og anvend ikke styreenheden i miljøer, der udsættes for påvirkninger fra atmosfæren (regn, sne, is), damp, aggressive gasser, og ligeledes ikke i eksplosivt eller brandfarligt miljø.

Følgende krav til omgivelsesforholdene gælder ved drift:

- temperatur: fra +5 °C til +45 °C
- relativ luftfugtighed: 0 – 95 % (ikke kondenserende)

For øvrige tilslutninger og installation af tilbehør henvises til afsnittet "Technical Information".

Anvendelse

Dette afsnit beskriver de vigtigste driftsprocedurer. For en detaljeret beskrivelse samt procedurer, der involverer tilslutninger eller tilbehør, henvises til afsnittet "Use" i bilag "Technical Information". Inden styreenheden anvendes, bør samtlige elektriske og pneumatiske tilslutninger udføres. Læs brugsanvisningen før pumpen tilsluttes.

ADVARSEL!



For at operere den sikkert, henvises der til den relevantepumpemanual før start.

BEMÆRK

Afbryderkontakten J1 skal forblive tilsluttet med aktuel bro, når der ikke udføres eksterne tilslutninger. Forvakuumpumpen og TwisTorr-pumpen skal fungere samtidigt.

Indikatorer og Kontakter på Styreenheden

Nedenfor vises styreenhedens front- og bagpanel. For yderligere information henvises til bilag "Technical Information".

Beskrivelse af frontpanel

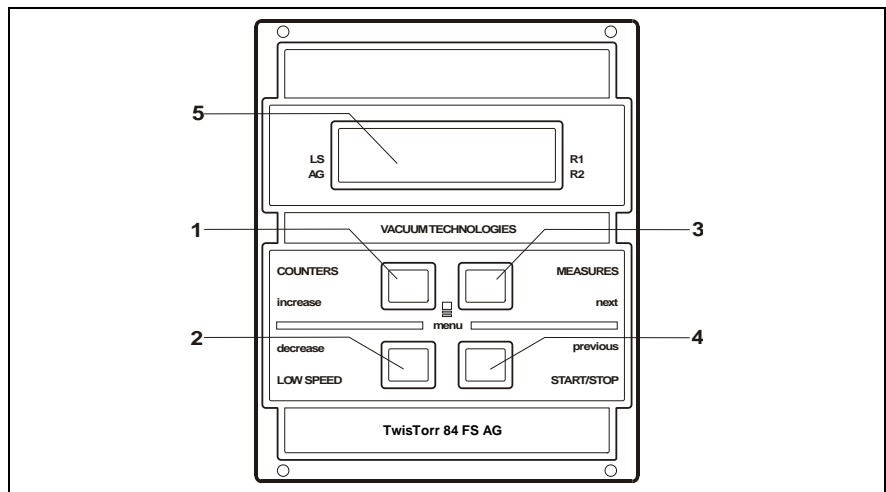

Figur 2 Frontpanelet på Styreenheden TwisTorr 84 FS AG

1	Trykknop til at hente cycle number, cycle time og pump lift frem på displayet.
2	Trykknop til installering af LOW SPEED driftvalg. Trykknappen fungerer kun, når der vælges fra frontpanelet. Tryk på knappen en gang for at få pumpen til at rotere med "standby" hastighed. Tryk på knappen igen for at gå ud af LOW SPEED driften.
3	Trykknop til at hente "pump current", "pump temperature", "pump power" og "rotational speed" frem på displayet. Trykknappen fungerer altid, uanset den valgte styretype. Når trykknapperne 3 og 1 holdes trykket ind samtidigt i mindst 2 sekunder, starter et program, der tillader, at programmere visse driftparametre.
4	Trykknop til overføring af START, STOP/RESET. Trykknappen fungerer kun, når der vælges fra frontpanelet. Tryk på knappen en gang for at starte pumpen, tryk på knappen igen for at standse pumpen. Hvis pumpen standser automatisk ved en fejl, tryk på denne knap en gang for at tilbagestille styreenheden, og yderligere en gang for at starte pumpen igen.
5	LCD-display med tal og bogstaver: punktmatrice, 2 rader med 16 tegn.

7 Istruktionsbog

Anvendelse

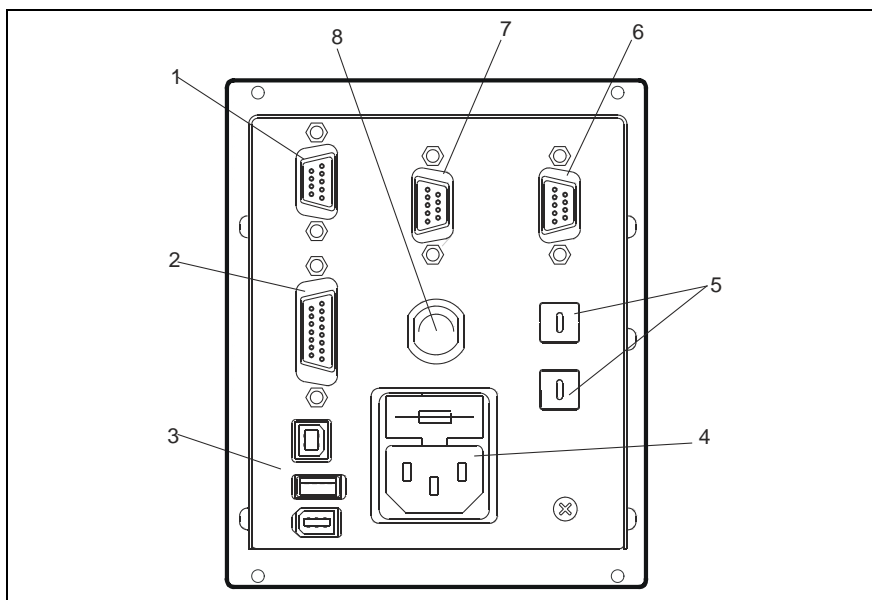

Figur 3 Bagpanelet på Styreenheden TwisTorr 84 FS AG

1	Indgangskontakt til logiske signaler (tilslutningskontakten leveres med special forbindelsesbro).
2	Udgangskontakt til logiske signaler og kontrol af pumpens frekvens samt programmerbar analog udgang.
3	Udtag (24 Vdc til blæseren der køler pumpen, udluftningsventilen og trykmåleren).
4	Indgangsmodul til styreenhed omfattende sikringer, strømudtag og ENC filter.
5	Drejekontakt til indstilling af Profibus adressen (ekstra).
6	Profibus (ekstra).
7	Seriell kontakt til fjernkontrol.
8	Kabel pumpe (længde 5 m).

Instruktion

Start af styreenheden

Styreenheden startes ved at sætte strømkablet i vægudtaget.

Start af pumpen

For at starte pumpen skal du bekræfte spæringsindgangen (kortslutningsstifter 3÷8 på P1) og trykke START-knappen på regulatorens frontpanel.

Stop af pumpen

Pumpen stopper ved at trykke på STOP-trykknappen på frontpanelet.

Vedligeholdelse

Styreenhederne i TwisTorr 84 FS AG Rack serien behøver ikke nogen vedligeholdelse. Ethvert indgreb på pumpen skal foretages af autoriseret personale.

Hvis pumpen går i stykker, kan man benytte sig af Agilent's reparations-service eller Agilent udvekslingsservice, hvor man kan få en repareret pumpe i bytte for den, der er gået i stykker.

ADVARSEL!

Inden der foretages noget som helst indgreb på styreenheden, skal strømmen først afbrydes.

Hvis en regulator skal kasseres, skal den bortskaffes i henhold til de specifikke nationale standarder.

Bortskaffelse

Betydningen af "WEEE" logoet på mærkaterne. Nedenstående symbol anvendes i overensstemmelse med det såkaldte EU-direktiv "WEEE". Symbolet (**kun gældende for EU-landene**) viser, at produktet, som det sidder på IKKE må bortskaffes sammen med affald fra private husholdninger eller industriel affald men skal indleveres på en godkendt affaldsstation. Vi opfordrer derfor slutbrugeren til at kontakte leverandøren af anordningen, enten fabrikken eller en forhandler, for igangsættelse af afhentnings- og bortskaffelsesprocessen efter nøje at have kontrolleret betingelserne i salgskontrakten.



For yderligere oplysninger henvises til:

<http://www.agilent.com/environment/product/index.shtml>

Fejlmeddelelser

Regulatoren vil selv-diagnosticere fejlårsager og vil vise følgende beskeder:

Tab. 1

MEDDELELSE	BESKRIVELSE	KONTROL
CHECK CONNECTION TO PUMP	Tilslutning mellem pumpe og styreenhed er defekt. eller Temperaturen på pumpen ligger under 0 °C.	Kontrollér at tilslutningskabel mellem pumpe og styreenhed er korrekt monteret samt at ingen afbrydninger forekommer. Tryk to gange på START for at starte pumpen igen.
WAITING INTERLOCK	Interlocksignalet findes på kontakt P1 p.g.a. kortslutning mellem stift 3 og stift 8 i kontakten J1 eller p.g.a. at det eksterne interlocksignal er åbent.	Tilslut stift 3 til stift 8 fra P1-stikket eller luk det eksterne spærringssignal.
PUMP OVERTEMP.	Temperaturen på det øverste leje eller pumpen overskrider 60 °C.	Vent på at temperaturen falder til under tærskelværdi. Tryk to gange på START for at starte pumpen igen.
CONTROLLER OVERTEMP.	Temperaturen på styreenhedens overskrider 70 °C. eller Temperaturen på styreenhedens køler overskrider 60 °C.	Vent på at temperaturen falder til under tærskelværdi. Tryk to gange på START for at starte pumpen igen.

7 Istruktionsbog

Fejlmeddelelser

MEDDELELSE	BESKRIVELSE	KONTROL
TOO HIGH LOAD	Den strøm, der trækkes af pumpen er for høj.	Kontrollér om pumpens rotor kan rotere frit. Tryk to gange på START for at starte pumpen igen.
SHORT CIRCUIT	En kortslutning er til stede på pumpe tilslutningen.	Kontrollér tilslutningerne og kredsløbene mellem pumpe og regulator. Tryk to gange på START for at starte pumpen igen.
SYSTEM OVERRIDE	Pumpen er blevet standset af et nødstopsignal fra en fjernkontakt.	Frakobl styreenhedens strømkabel og kontrollér årsagen til nødstopet. Sæt derefter strømkablet i. Tryk to gange på START, for at starte pumpen igen.
OVERVOLTAGE	Regulatorens strømforsyningskredsløb er defekt eller Regulatoren modtog en uventet overdreven spænding.	Tryk to gange på START-knappen for at starte pumpen igen. Hvis meddelelsen kommer igen tag kontakt med Agilent for nødvendig vedligeholdelse.
POWER FAIL	Fejl i strømforsyningssektionen.	Tag kontakt med Agilent for Vedligeholdelse.

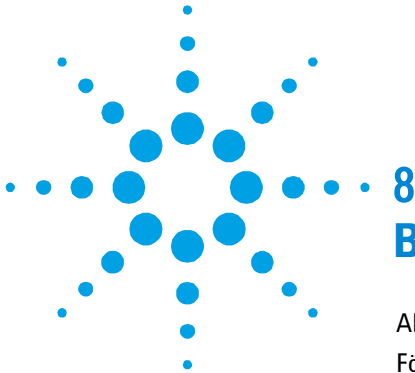

8 Bruksanvisning

Allmän Information	100
Förvaring	101
Förberedelser för installation	102
Installation	103
Användning	104
Indikatorer och Kontakter på Styrenheten	105
Beskrivning av frontpanel	105
Instruktioner för bruk	107
Start av styrenheten	107
Start av pumpen	107
Stopp av pumpen	107
Underhåll	107
Bortskaffning	108
Felmeddelanden	109

Översättning av originalinstruktionerna



Allmän Information

Utrustningen är avsedd för yrkesmässig användning. Användaren bör läsa denna bruksanvisning, samt övrig dokumentation från Agilent före användning av utrustningen. Agilent tar inget ansvar för skador som helt eller delvis orsakats av åsidosättande av instruktionerna, olämplig användning av person utan tillräcklig kunskap, obehörigt bruk av utrustningen eller hantering som strider mot gällande lokala föreskrifter.

Styrenheterna i TwisTorr 84 FS AG Rack serien är mikroprocessor-styrda frekvensomvandlare som består av komponenter med fast tillstånd. Styrenheterna är försedda med självdiagnos- och självskyddsfunktion.

Styrenhetens egenskaper:

- Front- / fjärr- /seriell styrning
- 24 Vdc styrning av pumpens kylfläkt
- Vent valve styrning
- Avläsning av pumphastighet efter kommando för stopp (avläsning av stopphastighet)
- Avläsning av tryck
- Profibus gränssnitt (option)
- Automatisk inställning av inspänning.

De följande avsnitten innehåller all information som behövs för att garantera operatörens säkerhet under driften. Detaljerade uppgifter finns i bilagan "Technical information".

I bruksanvisningen används följande standard-rubriker:

WARNING!



Varningsmeddelandena informerar operatören om att en speciell procedur eller en viss typ av arbete måste utföras exakt enligt anvisningarna. I annat fall finns risk för svåra personskador.

OBSERVER!

Detta varningsmeddelande visas framför procedurer som måste följas exakt för att undvika skador på maskinen.

OBSERVERA

Detta visar på viktig information i texten.

Förvaring

Följande krav på omgivningsförhållanden gäller vid transport och förvaring av styrenheten:

- temperatur: från -20 °C till +70 °C
- relativ luftfuktighet: 0 – 95 % (utan kondens)

Förberedelser för installation

Styrenheten levereras i ett särskilt skyddande emballage. Kontakta det lokala försäljningskontoret om emballaget visar tecken på skador som kan ha uppstått under transporten.

Se till att styrenheten inte tappas eller utsätts för stötar vid upppackningen.

Kasta inte packmaterialet i soporna. Materialet är återvinningsbart till 100 % och uppfyller EU-direktiv 85/399 om miljöskydd.

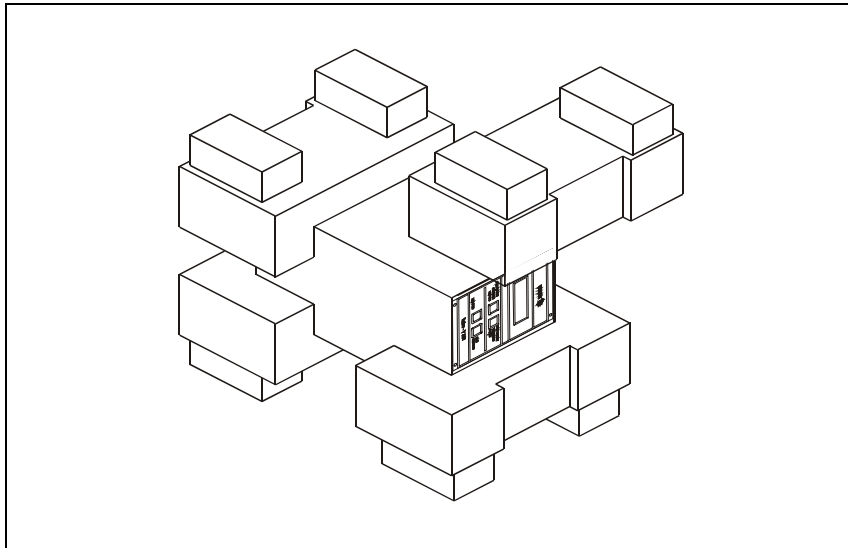

Figur 1 Styrenhetensförpackning

Installation

VARNING!



Styrenheten fungerar med en strömkabel som har tre ledare (se tabellen som visar de delar som kan beställas) och för användarens säkerhet ska den ha godkänd stickpropp enligt internationella standarder. Använd alltid denna strömkabel och anslut stickproppen till ett vägguttag med fungerande jordanslutning för att undvika elstötar och för iakttagelse av CE specifikationer. Spänningen inuti styrenheten kan nå höga värden och förorsaka allvarliga skador och dödsfall. Dra alltid ur strömkabeln från vägguttaget innan något installations- eller underhållsmoment utförs på styrenheten.

OBSERVERA

Styrenheten kan installeras på ett bord eller inuti ett därtill avsett rack. I samtliga fall måste dock kyl Luftn kunna cirkulera fritt kring apparaten. Installera och använd inte styrenheten i miljöer som utsätts för påverkan från atmosfären (regn, snö, is), damm, aggressiva gaser, och inte heller i explosiv eller brandfarlig miljö.

Följande krav på omgivningsförhållanden gäller vid drift:

- temperatur: från +5 °C till +45 °C
- relativ luftfuktighet: 0 – 95 % (utan kondens)

Beträffande övriga anslutningar och installation av tillbehör hänvisas till avsnittet "Technical Information".

Användning

Detta avsnitt beskriver de viktigaste driftmomenten. För en detaljerad beskrivning samt beträffande moment som involverar anslutningar eller tillbehör hänvisas till avsnittet "Use" i bilaga "Technical Information".

Innan styrenheten används bör samtliga elektriska och pneumatiska anslutningar utföras. Läs bruksanvisningen för den anslutna pumpen.

VARNING!



Referera till den relevanta pumpmanualen innan start för att använda den på ett säkert sätt.

OBSERVERA

Stängningskontakten J1 måste lämnas ansluten med aktuell brygga om ingen extern anslutning utförs. Förvakuumpumpen och TwisTorr-pumpen kan fungera samtidigt.

Indikatorer och Kontakter på Styrenheten

Nedan visas styrenhetens front- och bakpanel. För ytterligare information hänvisas till bilaga "Technical Information".

Beskrivning av frontpanel

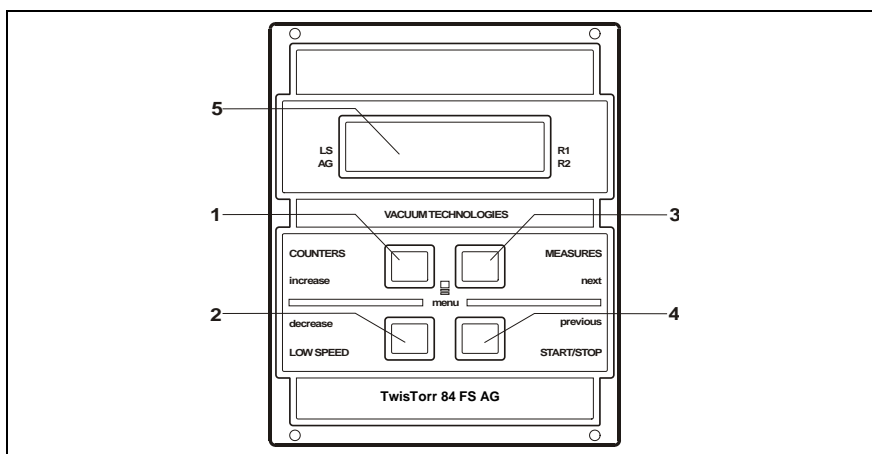

Figur 2 Frontpanelen på Styrenheten TwisTorr 84 FS AG

1	Tryckknapp för att hämta parametrarna cycle number, cycle time och pump life på displayen.
2	Tryckknapp för inställning av LOW SPEED driftsätt. Tryckknappen fungerar endast när styrsätt från frontpanelen har valts. Genom att trycka på knappen en gång kommer pumpen att rotera vid "standby" hastighet. Tryck på knappen igen för att gå ur LOW SPEED driftsättet.
3	Tryckknapp för att hämta parametrarna "pump current", "pump temperature", "pump power" och "rotational speed" på displayen. Tryckknappen fungerar alltid, oavsett det valda styrsättet. När tryckknapparna 3 och 1 hålls samtidigt intryckta i minst 2 sekunder, startas ett program som tillåter att programmera vissa driftparametrar.
4	Tryckknapp för överföring av START, STOP/RESET. Tryckknappen fungerar endast när styrsätt från frontpanelen har valts. Tryck på knappen en gång för att starta pumpen, tryck på knappen igen för att stanna pumpen. Om pumpen stannat automatiskt i samband med ett fel, tryck på denna knapp en gång för att återställa styrenheten, och ytterligare en gång för att starta om pumpen.
5	LCD-display med siffror och bokstäver: punktmatrix, 2 rader med 16 tecken.

8 Bruksanvisning

Användning

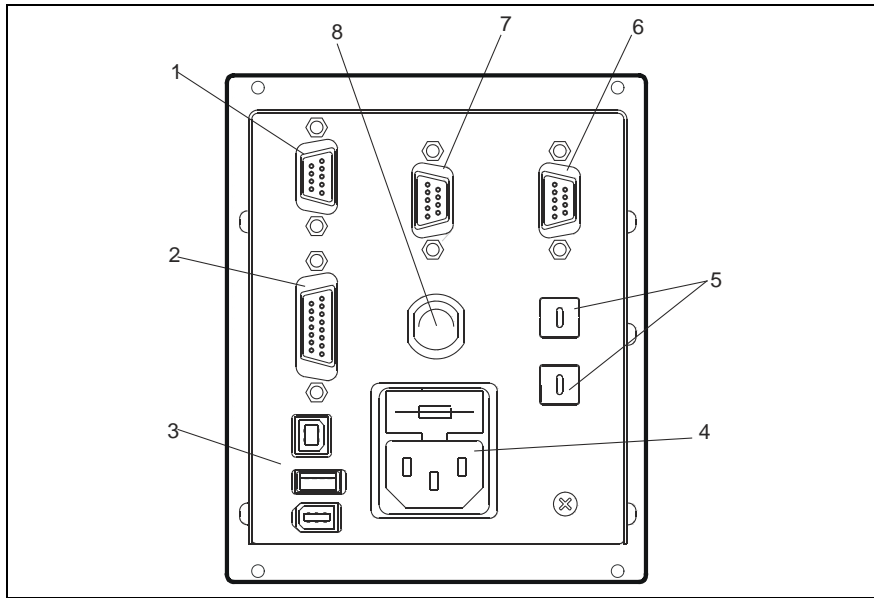

Figur 3 Bakre panel på Styrenheten TwisTorr 84 FS AG

1	Ingångskontakt för logiska signaler (anslutnings-kontakten levereras med speciell stängningsbrygga).
2	Kontakt för utgående logiksignaler och kontroll av pumpfrekvens plus programmerbar analog utgång.
3	Uttag (24 Vdc för kylfläkt, avluftningsventil och manometer).
4	Inmodul för styrenhet omfattande säkringar, strömuttag och ENC filter.
5	Vred för inställning av Profibus adressen (option).
6	Profibus (option).
7	Seriell kontakt för fjärrkontroll.
8	Pumpslang (längd 5 m).

Instruktioner för bruk

Start av styrenheten

Styrenheten startas enkelt genom att sätta strömkabeln i vägguttaget.

Start av pumpen

För att starta pumpen så bekräfta förreglingsingången (kortslutningsstift 3÷8 på P1) och tryck på knappen START på kontrollpanelen.

Stopp av pumpen

Pumpen stoppas genom att trycka på tryckknappen STOPP på frontpanelen.

Underhåll

Styrenheterna i TwisTorr 84 FS AG Rack serien är underhållsfria. Allt servicearbete måste utföras av auktoriserad personal.

Om styrenheten havererar, kontakta Agilent reparationsverkstad eller Agilent utbytesservice, som kan ersätta styrenheten med en renoverad styrenhet.

WARNING!

Innan något arbete utförs på styrenheten måste dess strömförsörjning brytas.



Om en styrenhet måste skrotas så ska den kastas bort i enlighet med de särskilda nationella standarderna.

Bortskaffning

Betydelse av logotypen "WEEE" på etiketterna. Symbolen som visas nedan har tillämpats i enlighet med CD-direktivet som har betecknats som "WEEE". Den här symbolen (**gäller endast i de länder som tillhör den Europeiska Unionen**) indikerar att produkten på vilken symbolen har applicerats INTE får skaffas bort tillsammans med vanliga hushålls- eller industriavfall, men att däremot ett differentierat uppsamlingsystem måste upprättas. Vi rekommenderar därför att slutanvändaren tar kontakt med leverantören av anordningen, oberoende om det handlar om moderföretaget eller återförsäljaren, för att kunna starta uppsamlings- och bortskaffningsprocessen, detta efter lämplig kontroll av kontraktsevenliga tidsgränser och försäljningsvillkor.



För mer information, se:

<http://www.agilent.com/environment/product/index.shtml>

Felmeddelanden

Styrenheten kommer att självdiagnostisera vissa fel och kommer att visa följande meddelande:

Tab. 1

MEDDELANDE	BESKRIVNING	ÅTGÄRD
CHECK CONNECTION TO PUMP	Anslutningen mellan pump och styrenhet är defekt. eller också Pumpens temperatur ligger under 0 °C.	Kontrollera att anslutningskabeln mellan pump och styrenhet är ordentligt monterad samt att inget avbrott förekommer. Tryck två gånger på knappen START för att starta om pumpen.
WAITING INTERLOCK	Interlock-signalen finns på kontakt P1 på grund av kortslutning mellan stift 3 och stift 8 i kontakten J1, eller på grund av att den externa interlock-signalen är öppen.	Anslut stift 3 till stift 8 på kontakten P1, eller stäng den externa förreglingssignalen.
PUMP OVERTEMP.	Temperaturen på det övre lagret eller pumpen överskrider 60 °C.	Vänta tills temperaturen sjunker under tröskelvärdet. Tryck två gånger på knappen START för att starta om pumpen.
CONTROLLER OVERTEMP.	Temperaturen på styrenhetens överskrider 70 °C. eller också Temperaturen på styrenhetens kylare överskrider 60 °C.	Vänta tills temperaturen sjunker under tröskelvärdet. Tryck två gånger på knappen START för att starta om pumpen.

8 Bruksanvisning

Felmeddelanden

MEDDELANDE	BESKRIVNING	ÅTGÄRD
TOO HIGH LOAD	Den ström som förbrukas av pumpen är för hög.	Kontrollera att pumpens rotor kan rotera fritt. Tryck två gånger på knappen START för att starta om pumpen.
SHORT CIRCUIT	En kortslutning finns på pumpkopplingen.	Kontrollera kopplingar och kortslutningar mellan pump och styrenhet. Tryck två gånger på knappen START för att starta om pumpen.
SYSTEM OVERRIDE	Pumpen har stannats av en nödstoppsignal från en fjärrkontakt.	Frånkoppla styrenhetens strömkabel och kontrollera nödstoppets orsak. Sätt därefter i strömkabeln. Tryck två gånger på knappen START för att starta om pumpen.
OVERVOLTAGE	Strömförsörjningskrets i styrenheten är felaktig eller styrenheten fick en oväntat hög spänning.	Tryck två gånger på knappen START för att starta om pumpen. Om meddelandet visas igen, ta kontakt med Agilent för nödvändigt underhåll.
POWER FAIL	Fel med strömförsörjningen.	Ta kontakt med Agilent för Underhåll.

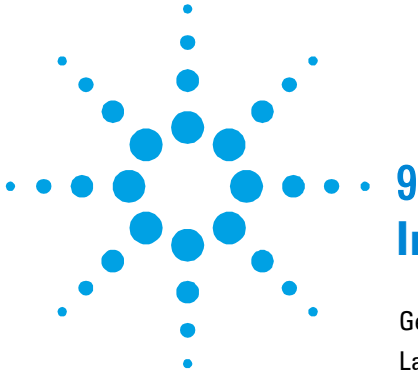

9

Instruksjon Manual

Generell informasjon	112
Lagring	113
Forberede installasjonen	114
Installasjon	115
Bruk	116
Indikatorer og Kontakter på Styreenheten	117
Beskrivelse av frontpanelet	117
Instruksjoner for bruk	119
Starte styreenheten	119
Starte pumpen	119
Stoppe pumpen	119
Vedlikehold	119
Eliminering	120
Feilmeldinger	121

Oversetting av den opprinnelige samsvarserklæringen



Generell informasjon

Dette utstyret er beregnet til bruk av profesjonelle brukere. Brukeren bør lese denne brukerveiledningen og all annen informasjon fra Agilent før utstyret tas i bruk. Agilent kan ikke holdes ansvarlig for hendelser som skjer på grunn av manglende oppfølging, selv delvis, av disse instruksjonene, feilaktig bruk av utrenet personell, ikke godkjente endringer av utstyret eller handlinger som på noen måte er i strid med nasjonale bestemmelser. Styreenhetene i TwisTorr 84 FS AG Rack serien er mikroprosessor-styrte frekvensomvendere, som består av komponenter med fast tilstand. Styreenhetene har funksjoner for selvdiagnose og selvbeskyttelse.

Styreenhetens karakteristikk:

- Frontal virksomhet / fjern / seriell
- Igangsetting av kjøleviften på 24 Vdc på pumpen
- Igangsetting av vent valve
- Avlesing av pumpehastighet etter stoppekommando (avlesing av stoppehastighet)
- Avlesing av trykk
- Grensesnitt Profibus (valgfritt)
- Automatisk innstilling av inngangsspenning

De følgende avsnittene inneholder all informasjon som er nødvendig for å sikre brukeren når utstyret er i bruk. For mer detaljert bruk vises det til tillegget "Technical Information".

Denne veiledningen bruker følgende standard-protokoll:

ADVARSEL!



Disse meldingene skal tiltrekke seg brukerens oppmerksomhet til en spesiell fremgangsmåte eller praksis som, hvis den ikke følges, kan medføre alvorlige skader.

FORSIKTIG!

Denne advarselen vises foran fremgangsmåter som, dersom de ikke følges, kan fore til at utstyret skades.

MERK

Merknadene inneholder viktig informasjon som er hentet fra teksten.

Lagring

Når styreenhetene transporteres eller lagres, må følgende forhold være oppfylt:

- temperatur: fra 20 °C til +70 °C
- relativ fuktighet: 0 – 95 % (uten kondens)

Forberede installasjonen

Styreenheten leveres i en spesiell beskyttelsesemballasje. Viser denne tegn på skader som kan ha oppstått under transporten, må du ta kontakt med det lokale salgskontoret.

Når styreenheten pakkes ut, må du passe på at den ikke slippes ned eller utsettes for noen form for støt. Emballasjen må ikke kastes på en ulovlig måte. Alle materialer er 100 % resirkulerbare og er i samsvar med EU-direktiv 85/399 om miljøbeskyttelse.

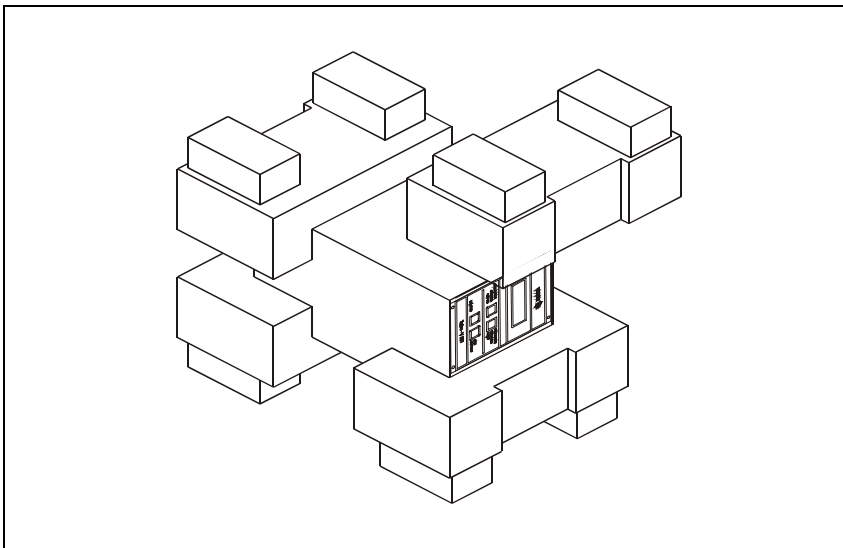

Figur 1 Styreenhetens emballasje

Installasjon

ADVARSEL!



Styreenheten må koples til en strømkabel med tre ledere (se tabellen over deler som kan bestilles) med et støpsel godkjent i henhold til internasjonale standarder til sikkerhet for brukeren. Bruk alltid denne strømkabelen og sett støpselet i en kontakt med passende jordledning, for å unngå elektriske støter og for å holde seg til CE-normene. Inne i styreenheten utvikles høye spenninger som kan føre til alvorlige skader eller dødsfall. Kople alltid strømkabelen fra strømmettet før enhver installering eller vedlikehold av styreenheten utføres.

MERK

Styreenheten kan installeres på et bord eller inne i et passende stativ. Uansett så må kjøleluften kunne sirkulere fritt rundt apparatet. Ikke installer eller bruk styreenheten i miljøer som utsettes for regn, snø eller is, støv, aggressive gasser, eksplosjonsfarlige miljøer eller i miljøer med stor brannfare.

Under bruk må følgende forhold respekteres:

- temperatur: fra +5 °C til +45 °C
- relativ fuktighet: 0 – 95 % (uten kondens)

Når det gjelder andre tilkoplinger og installasjon av ekstrautstyr vises det til avsnittet "Technical Information".

Bruk

Dette avsnittet beskriver de viktigste driftsmomentene. For en detaljert beskrivelse samt moment som omfatter tilkoplinger eller ekstrautstyr vises det til avsnittet "Use" i vedlegget "Technical Information". Før styreenheten tas i bruk bør samtlige elektriske og pneumatiske tilkoplinger gjøres. Les brukerveiledningen for pumpen som er tilkopleet.

ADVARSEL!

Se i den relevantepumpehåndboken for sikkerbruk før du starter.



MERK

Lukkekontakten J1 må være tilkopleet aktuell brygge dersom det ikke skjer en annen ekstern tilkopling. Forvakuumpumpen og TwisTorr-pumpen må fungere sammen.

Indikatorer og Kontakter på Styreenheten

Nedenunder er frontpanelet og bakpanelet på styreenheten illustrert. For ytterligere informasjon vises det til avsnittet "Accessories and Spare Parts" i vedlegget "Technical Information".

Beskrivelse av frontpanelet

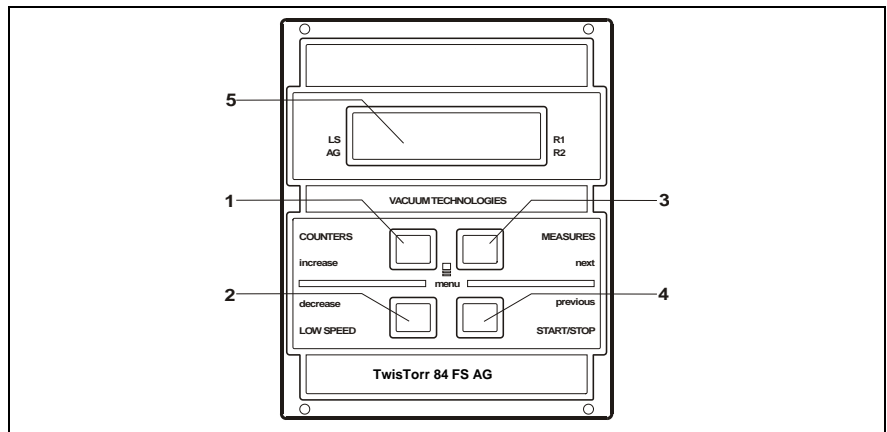

Figur 2 Frontpanelet på styreenheten TwisTorr 84 FS AG

1	Trykknapp for å vise parametrene cycle number, cycle time og pump life på displayet.
2	Trykknapp for innstilling av LOW SPEED drift. Trykknappen fungerer kun når det er valgt styremåte fra frontpanelet. Ved å trykke på knappen én gang, roterer pumpen i "stand-by" hastighet. Trykk på knappen igjen for å gå ut av LOW SPEED drift.
3	Trykknapp for å vise parametrene "pump current", "pump temperature", "pump power" og "rotational speed" på displayet. Trykknappen fungerer alltid, uavhengig av styremåten. Når trykknappene 3 og 1 trykkes ned samtidig i minst to sekunder, startes et program som tillater programmering av visse driftsparametre.
4	Trykknapp for overføring av START, STOP/RESET. Trykknappen fungerer kun når det er valgt styremåte fra frontpanelet. Trykk på knappen en gang for å starte pumpen, trykk på knappen igjen for å stanse pumpen. Har pumpen stanset automatisk i forbindelse med en feil, trykk en gang på denne knappen for å tilbakestille styreenheten, en gang til for å startet pumpen.
5	LCD-display med siffer og bokstaver: punkt-matrise, 2 rader med 16 tegn.

9 Instruksjon Manual

Bruk

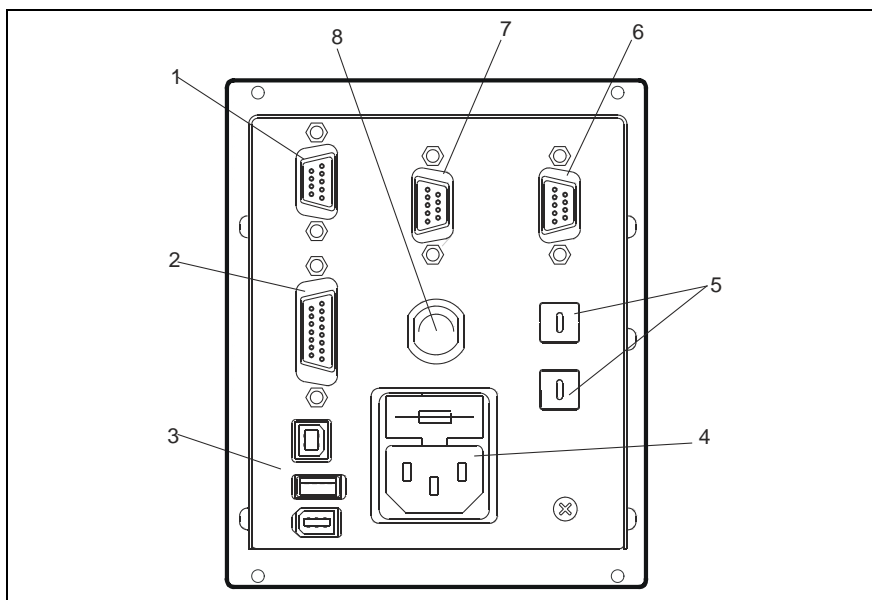

Figur 3 Bakpanelet på styreenheten TwisTorr 84 FS AG

1	Inngangskontakt for logiske signaler (tilkoplings-kontakten leveres med spesiell lukkebrygge).
2	Port for logiske signaler ut og monitoring av pumpefrekvens og analogisk utgang programmerbar.
3	Uttak (24 Vdc på kjøleviften, på pumpen, vifte ventil og manometer).
4	Inngangsmodule til mating av styreenheten som består av sikringer, matekontakt og ENC-filter.
5	Dreiebryter for innstilling av Profibusadresse (valgfritt).
6	Profibus (valgfritt).
7	Serialport for fjernkontroll.
8	Pumpeledning (5 meter lang).

Instruksjoner for bruk

Starte styreenheten

Styreenheten startes ved å sette strømkabelen i veggkontakten.

Starte pumpen

For å starte pumpen, bekreft sperreingang (kortslutnings tapper 3 ÷8 på P1) og trykk på Start-trykknappen på kontrollerens frontpanel.

Stoppe pumpen

Pumpen stoppes ved å trykke på knappen STOPP på frontpanelet.

Vedlikehold

TwisTorr 84 FS AG Rack seriens styreenheter er vedlikeholdsfrie. Alt arbeid på styreenheten må kun utføres av autorisert personell.

Dersom styreenheten stanser, må du ta kontakt med Agilents reparasjonsservice eller med Agilents avanserte bytteservice, som kan tilby overholte styreenheter til erstatning for den ødelagte styreenheten.

ADVARSEL!

Før noe arbeid utføres på styreenheten, må den frakoples strømmettet.



Dersom en kontroller må skrotes, så må den bli kastet i henhold med spesifikke nasjonale standarder.

Eliminering

Betydelsen av symbolet på logo "WEEE" på etikettene. Symbolet nedenunder som finnes, er anvendt i henhold til EC-direktiv kalt "WEEE". Dette symbolet (**som bare gjelder for land i Det europeiske fellesskap**), viser at produktet som det sitter på, IKKE må behandles som vanlig hus-industriavfall, men må legges i kildesortering. Derfor oppfordrer man den sluttelige brukeren av anordningen å henvende seg til leverandøren av anordningen, som kan være et firma eller en forhandler, som sørger for oppsamling og eliminering etter å ha kontrollert avtal og betingelser i kjøpekontrakten.



For mer informasjon se:

<http://www.agilent.com/environment/product/index.shtml>

Feilmeldinger

Kontrolleren vil selvdiagnostisere noen feilårsaker og vil vise de følgende meldinger:

Tab. 1

MELDING	BESKRIVELSE	FORHOLDSREGEL
CHECK CONNECTION TO PUMP	Defekt kopling mellom pumpe og styreenhet. Eller Pumpen har en temperatur under 0 °C.	Kontroller at tilkoplingskabelen mellom pumpe og styreenhet er skikkelig montert samt at kabelen ikke er skadet. Trykk to ganger på knappen START for å starte pumpen.
WAITING INTERLOCK	Låsesignalet for kontakt P1 skyldes en kortslutning mellom stift 3 og stift 8 i kontakten J1 eller fordi det eksterne låsesignalet er åpent.	Koble stift 3 til stift 8 på P1 kontakten, eller lukk det eksterne sperresignalet.
PUMP OVERTEMP.	Temperaturen på det øvre lageret eller pumpen er over 60 °C.	Vent til temperaturen synker under terskelverdien. Trykk to ganger på knappen START for å starte pumpen.
CONTROLLER OVERTEMP.	Temperaturen på styreenhetens er over 70 °C. Eller Temperaturen på radiatoren på styreenheten er over 60 °C.	Vent til temperaturen synker under terskelverdien. Trykk to ganger på knappen START for å starte pumpen.

9 Instruksjon Manual

Feilmeldinger

MELDING	BESKRIVELSE	FORHOLDSREGEL
TOO HIGH LOAD	Strømmen dratt av pumpen er for høyt.	Kontroller om pumpens rotor kan rotere fritt. Trykk to ganger på knappen START for å starte pumpen.
SHORT CIRCUIT	En kortslutning er tilstede på pumpekoblingen.	Sjekk tilkoblinger og kortslutninger mellom pumpe og kontroller. Trykk to ganger på knappen START for å starte pumpen.
SYSTEM OVERRIDE	Pumpen har stanset av et nødstoppsignal en fra fjernkontakt.	Kople fra styreenhetens strømkabel og finn frem til årsaken til nødstoppen. Kople deretter maskinen til strømnettet igjen. Trykk to ganger på knappen START for å starte pumpen.
OVERVOLTAGE	Kontrollerens strømforsyningskrets er defekt, ellers mottok Kontrolleren en uventet høy spenning.	Trykk to ganger på knappen START for å starte pumpen igjen. Vises feilmeldingen om igjen, må du ta kontakt med Agilent for nødvendig vedlikehold.
POWER FAIL	Svikt i strømforsynings seksjonen.	Henvend deg til Agilent for vedlikehold.



10 Ohjekäsikirja

Yleisiä tietoja	124
Varastointi	125
Valmistelut asennusta varten	126
Asennus	127
Käyttö	128
Valvojan Säätimet, Osoittimet ja Liittimet	129
Etupaneelin kuvaus	129
Käyttötoimenpiteet	131
Valvojan käynnistys	131
Pumpun käynnistys	131
Pumpun pysäyttäminen	131
Huolto	131
Hävittäminen	132
Vianetsintä	133

Alkuperäisen ohjeiden käännös



Yleisiä tietoja

Tämä laite on tarkoitettu ammattimaiseen käyttöön. Ennen laitteen käyttöönottoa käyttäjän tulee lukea huolellisesti mukana seuraava käyttöohje sekä kaikki muut Agilentin toimittamat lisätiedot. Agilent ei vastaa seurauksista, jotka johtuvat laitteen käyttöohjeiden täydellisestä tai osittaisesta laiminlyömisestä, ammattitaidottomien henkilöiden suorittamasta laitteen virheellisestä käytöstä, valtuuttamattomista toimenpiteistä tai maakohtaisten säädösten ja normien vastaisesta käytöstä.

Sarjan TwisTorr 84 FS AG Rack valvojat ovat mikroprosessorien valvomia kiinteistä materiaaleista tehtyjä taajuudenmuuntimia, jotka kykenevät itsemäärittelyyn ja itsesuojaukseen.

Valvojan ominaisuudet:

- Käytettävyys etupaneelistä / etäkäyttö / sarjakäyttö
- Pumpun jäähdytysviivikon 24V tasavirtaohjaus
- Vent valve ohjaus
- Pumpun nopeuden luku pysäytyskäskyn jälkeen (pysäytysnopeuden luku)
- Paineen luku
- Profibus-liitäntä (valinnainen)
- Automaattinen sisääntulon jännitteen asetus.

Seuraavilla sivuilla on luettavissa tarpeelliset tiedot laitteen käyttäjän turvallisuuden takaamiseksi laitteen käytön aikana. Yksityiskohtaiset tiedot löytyvät liitteestä "Technical Information".

Tämä ohjekirja käyttää seuraavia merkintöjä:

VAROITUS!



Vaara-merkinnät saavat käyttäjän huomion kiinnittymään erityisiin toimintotapoihin, joiden seuraamatta jättäminen voi aiheuttaa vakavia henkilövaurioita.

HUOMIO!

Huomio-merkinnät varoittavat toiminnoista, joiden laiminlyönti voi johtaa laitteen vaurioitumiseen.

HUOM

Huomiot sisältävät tärkeää tekstistä otettua tietoa.

Varastointi

Valvojan kuljetuksen ja varastoinnin aikana tulevat seuraavat ympäristövaatimukset olla täytettyinä:

- lämpötila: -20 °C ja +70 °C asteen välillä
- suhteellinen kosteus: 0 – 95 % (ilman lauhdetta)

Valmistelut asennusta varten

Valvoja toimitetaan erityisessä suojaavassa pakkauksessa. Mikäli havaitsette mahdollisesti kuljetuksen aikana tapahtuneita vaurioita, ottakaa yhteys paikalliseen myyntitoimistoon.

Pakkauksen purkamisen yhteydessä huolehtikaa, että valvoja ei pääse putoamaan ja välttää sen joutumista iskujen kohteeksi.

Älkää jättäkö pakkausta ympäristöön. Materiaali voidaan kokonaisuudessaan kierrättää ja se vastaa EU:n 85/399 direktiiviä ympäristön suojelusta.

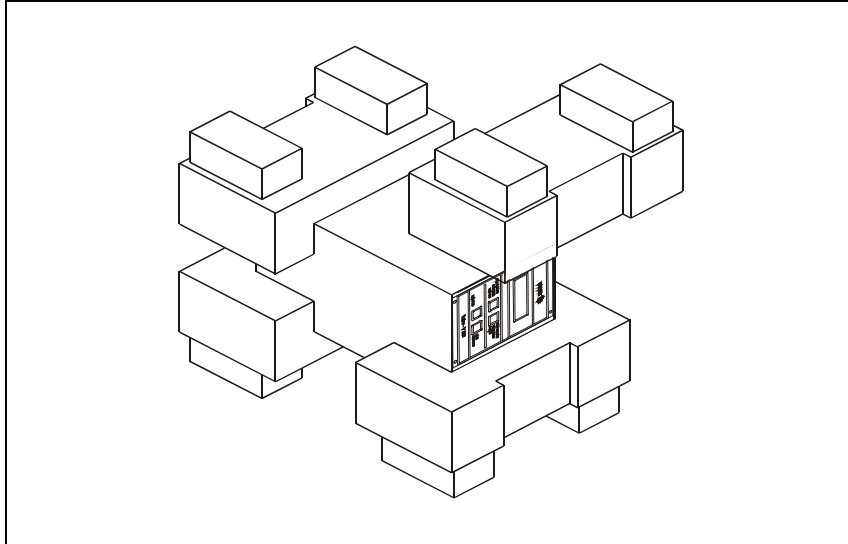

Kuva 1 Valvojan pakkaus

Asennus

VAROITUS!



Käyttäjän turvallisuuden vuoksi valvojan virranottoon on käytettävä kolmijohtimista sähkökaapelia (ks. tilattavien osien taulukko), jonka pistoke on kansainvälisesti hyväksyttyä tyyppiä. Käytä aina tätä kaapelia ja kiinnitä pistoke asianmukaisesti maadoitettuun pistorasiaan sähköiskujen välttämiseksi ja CE-vaatimusten noudattamiseksi. Valvojan sisällä muodostuu korkeajännitettä, joka voi aiheuttaa vakavia vammoja tai jopa kuoleman. Ennen mihinkään asennus- tai huoltotoimenpiteisiin ryhtymistä valvojan pistoke on irrotettava pistorasiasta.

HUOM

Valvoja voidaan asentaa pöydän päälle tai siihen tarkoitukseen sopivan hyllyn sisään. Joka tapauksessa huolehtikaa siitä, että riittävä jäähdytysilma pääsee vapaasti kiertämään laitteen sisällä. Älkää asentako ja/tai käyttäkö valvojaa tiloissa, joissa se joutuu alttiiksi ympäristökijöille (sade, jää, lumi), pölylle, syövyttävälle kaasulle, räjähdysalttiissa ympäristössä tai tiloissa, joissa paloriski on suuri.

Toiminnan aikana tulee noudattaa seuraavia ympäristöolosuhteita koskevia sääntöjä:

- lämpötila: 5 °C ja +45 °C välillä
- suhteellinen kosteus: 0 - 95% välillä (ilman lauhdetta)

Muiden kytkentöjen ja valinnaisten lisälaitteiden asennusten suorittamiseksi, katsokaa kappaletta "Technical Information".

Käyttö

Tähän kappaleeseen on kirjattu tärkeimmät käyttötoimenpiteet. Tarkempia lisätietoja sekä kytkentöjä ja valinnaisia lisälaitteita koskevien toimenpiteiden suorittamista käsitteleviä tietoja löydätte kappaleesta "Käyttö", joka on "Tekniset tiedot"- kappaleen liitteenä. Ennen valvojan käyttöä suorittakaa kaikki sähkökytkennät seuraten kytkettävän pumpun käyttöohjeita.

VAROITUS!



Tutustu pumpun käyttöohjeeseen ennen aloittamista pumpun turvalliseksi käyttämiseksi.

HUOM

Sulkimen J1 liitin tulee jättää yhdyskaapelilla kytketyksi, mikäli ulkoisia kytkentöjä ei suoriteta. Esityhjiöpumppu ja TwisTorr-pumppu voidaan käynnistää samanaikaisesti.

Valvojan Säätimet, Osoittimet ja Liittimet

Seuraavassa on kuvattu valvojan etu- ja takapaneelit. Tarkempia lisätietoja saatte kappaleesta "Technical Information".

Etupaneelin kuvaus

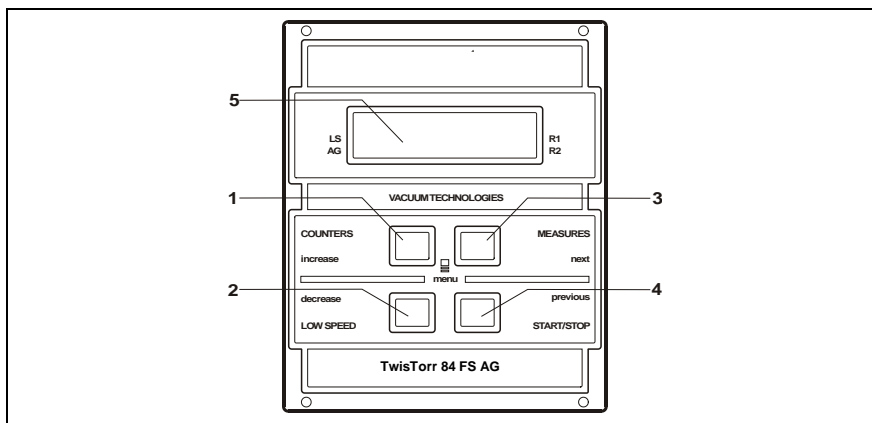

Kuva 2 Valvojen TwisTorr 84 FS AG etupaneelit

1	Painonappi, jonka avulla näyttöön saadaan kiertonumero, kiertoaika ja pumpun toiminta.
2	LOW SPEED -moodin valintaan käytettävä painonappi. Se aktivoituu vain silloin, kun etupaneelin toiminta-moodi on valittu. Yhden kerran painettaessa pumppu kiertää valmistustila-nopeudella. Painonappia uudelleen painettaessa LOW SPEED- moodi disaktivoituu.
3	Painonappi, jonka avulla näyttöön saadaan pumpun sähkövirran, pumpun lämpötilan, pumpun tehon ja kiertonopeuden parametrit. Tämä on aina aktiivi riippumatta valitusta toimintamoodista. Painamalla painonappeja 3 ja 1 vähintään kahden sekunnin ajan, aktivoituu ohjelma, jonka avulla on mahdollista ohjelmoida joitakin toimintaparametrejä.
4	START, STOP/RESET (KÄYNNISTYKSEN, PYSÄYTYKSEN/UUELLEN ASETUKSEN) käskyjen painonappi. Se aktivoituu vain silloin, kun etupaneelin toiminta-moodi on valittu. Yhden kerran painettaessa käynnistysvaihe aktioituu. Uudelleen painettaessa pumppu pysähtyy. Mikäli pumppu on toimintahäiriön vuoksi pysähtynyt automaattisesti, painakaa painonappia yhden kerran, jolloin valvoja saadaan asetettua uudelleen. Toisen kerran painonappia painettaessa pumppu käynnistyy.
5	Kirjainnumerollinen digitaalinen näyttö: pistematriisi, 2 riviä x 16 merkkiä.

10 Ohjekäsikirja

Käyttö

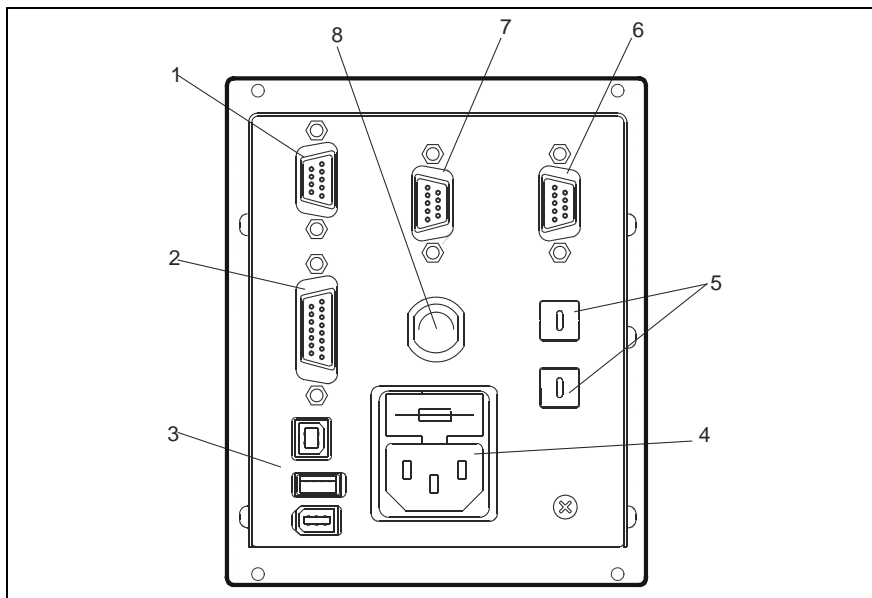

Kuva 3 Valvojen TwisTorr 84 FS AG takapaneli

1	Logiikkasegnaalien tulokytentä (pariliittimet toimitetaan niihin sopivilla yhdyskaapelisulkijalla).
2	Lähtevien logiikkasignaalien ja pumpun taajuuden tarkkailun sekä ohjelmoitavan analogisen ulostulon liitin.
3	Virran ulostuloliitin (24 V tasavirta pumpun jäähdytystuulettimelle, ilmanpoistoveniilille ja tyhjiömittarille).
4	Valvojan tulovirran moduuli, johon sisältyvät sulakkeet, virtapistoke ja suodatin ENC.
5	Profibus-osoitteen asettamiseen tarkoitettu kiertokytkin (valinnainen).
6	Profibus (valinnainen).
7	Etäohjauksen sarjaliitäntä.
8	Pumpun kaapeli (5 metriä pitkä)

Käyttötoimenpiteet

Valvojan käynnistys

Valvoja käynnistyy asetettaessa virtakaapeli pistorasiaan.

Pumpun käynnistys

Pumpun käynnistämiseksi, vahvista lukituksen syöttö (kääntämällä vivut 3-8 asentoon P1) ja painaa etupaneelin painiketta START.

Pumpun pysäyttäminen

Pumppu pysähtyy painettaessa etupaneelissa olevaa STOP-painonappia.

Huolto

TwisTorr 84 FS AG Rack sarjan valvojat eivät kaipaa minkäänlaista huoltoa. Mahdolliset valvojaan tehtävät toimenpiteet tulee jättää aina valtuutetun henkilön tehtäviksi.

Toimintahäiriön sattuessa on mahdollista käyttää Agilentin korjauspalvelua tai "Agilent advance exchange service" -palvelua, jolloin on mahdollista vaihtaa rikkoontunut valvoja ladattuun valvojaan.

VAROITUS!

Ennen minkä tahansa valvojaan tehtävän toimenpiteen suorittamista irrottakaa sähkökaapeli pistorasiasta.

Jos ohjain joudutaan postamaan käytöstä, tulee se hävittää noudattaen erityisiä kansallisia standardeja.

Hävittäminen

Pakkausmerkinnöissä olevan WEEE-logon merkitys. Alla näkyvä merkki on lisätty pakkaukseen EY:n ns. WEEE-direktiivin mukaisesti. Merkki (**koskee ainoastaan Euroopan Unionin jäsenmaita**) tarkoittaa, että tuotetta EI saa hävittää tavallisen kotitalous- tai teollisuusjätteen mukana, vaan se on toimitettava erilliseen keräyspisteeseen. Loppukäyttäjää kehoitetaan sen vuoksi ottamaan keräys- ja hävittämisprosessia varten yhteyttä laitteen toimittajaan, olipa se sitten laitteen valmistaja tai jälleenmyyjä, tarkastettuaan ensin kaupan sopimusehdot.



Katso lisätietoja kohdasta:

<http://www.agilent.com/environment/product/index.shtml>

Vianetsintä

Ohjain määrittelee itse joitakin vikoja ja näyttää siinä tapauksessa seuraavanlaisia viestejä:

Tab. 1

VIESTI	VIKA	KORJAUSTOIMENPITEET
CHECK CONNECTION TO PUMP	Toimintahäiriö pumpun ja valvojan liitännässä. Tai Pumpun lämpötila on alempi kuin 0 °C.	Tarkistakaa että pumpun ja valvojan välinen yhteyskaapeli on hyvin kiinnitetty päistään eikä sen varrella ole esteitä. Painakaa kaksi kertaa painonappia START jolloin pumppu käynnistyy.
WAITING INTERLOCK	Lukitussignaali (interlock) liittimessä P1 on aktiivinen johtuen liittimen J1 neurojen 3 ja 8 välillä tapahtuneen oikosulun keskeytyksestä tai ulkoisen lukitussignaalin (interlock) avautumisesta.	Yhdistä P1 liittimen neurojen 3 neurojen 8, tai sulje ulkoinen lukitussignaali.
PUMP OVERTEMP.	Ylemmän laakerin tai pumpun lämpötila on ylittänyt 60 °C.	Odottakaa että lämpötila putoaa kynnyksarvon alapuolelle. Painakaa painonappia START kaksi kertaa jolloin pumppu käynnistyy.
CONTROLLER OVERTEMP.	Valvojan muuntajan lämpötila on 70 °C. Tai Valvojan lämmittimen lämpötila on korkeampi kuin 60 °C.	Odottakaa, että lämpötila putoaa kynnyksarvon alapuolelle. Painakaa painonappia START kaksi kertaa jolloin pumppu käynnistyy.

10 Ohjekäsikirja

Vianetsintä

VIESTI	VIKA	KORJAUSTOIMENPITEET
TOO HIGH LOAD	Pumpun nykyinen virtaama on liian korkea.	Tarkistakaa, että pumpun roottori pyörii vapaasti. Painakaa painonappia START kaksi kertaa jolloin pumppu käynnistyy.
SHORT CIRCUIT	Pumpun liitin on oikosulussa.	Tarkista liitännät ja oikosulut pumpun ja ohjaimen välillä. Painakaa painonappia START kaksi kertaa jolloin pumppu käynnistyy.
SYSTEM OVERRIDE	Kaukokytimestä tuleva hälytysignaali on pysäyttänyt pumpun.	Irroitakaa valvojan sähkökaapeli verkkovirrasta ja korjatkaa hälytyksen aiheuttaja. Kytkekää sähkökaapeli uudelleen ja painakaa painonappia START kaksi kertaa jolloin pumppu käynnistyy.
OVERVOLTAGE	Ohjaimen virtapiiri on viallinen tai ohjaimen tuli äkillinen ylijännite.	Painakaa painonappia START kaksi kertaa, jolloin pumppu käynnistyy. Mikäli viesti näkyy uudelleen kääntykää Agilent huoltopalvelun puoleen.
POWER FAIL	Vika virtalähteessä.	Kääntykää Agilent-yhtiön puoleen Huoltoa tarvittaessa.

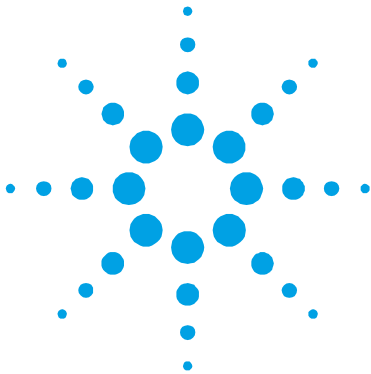

11 Felhasználói Kézikönyv

Általános információk	136
Tárolás	137
A telepítésre való előkészítés	138
Telepítés	139
Használat	140
A vezérlő parancsai, kijelzői és csatlakozói	141
Az előlap leírása	141
Használati eljárások	143
A vezérlő bekapcsolása	143
A szivattyú beindítása	143
A szivattyú leállítása	143
Karbantartás	143
Megsemmisítés	144
Hibaüzenetek	144

Az eredeti utasítás fordítása



Általános információk

Ez a berendezés hivatásos használatra tervezett. A felhasználónak, a berendezés használatát megelőzően, gondosan el kell olvasnia a felhasználói kézikönyvet és minden egyéb, a Agilent által szolgáltatott információt. A Agilent elhárít magától minden esetleges felelősséget, mely a felhasználói utasítások teljes vagy részleges figyelmen kívül hagyásához, a nem kiképzett személyzet által történő nem megfelelő használathoz, meghatalmazás nélküli beavatkozásokhoz, vagy a specifikus nemzeti irányelvekkel ellentétes használathoz kötődik.

A TwisTorr 84 FS AG Rack sorozatú vezérlők mikroprocesszoros vezérlésű, szilárdtest-elemekkel realizált frekvencia-átalakítók, öndiagnosztikai és saját védelmi képességekkel.

A vezérlő tulajdonságai:

- Előlapról történő / táv- / soros vonalon keresztüli működtetés
- A szivattyú hűtőventillátorának 24 Vdc feszültségen történő vezérlése
- A vent valve vezérlése
- A szivattyú sebességének leolvasása a leállítási parancsot követően (leállási sebesség leolvasása)
- A nyomásérték leolvasása
- Profibus illesztő (opcionális)
- A bemeneti feszültség automatikus beállítása.

Az elkövetkező szakaszok tartalmazzák mindazokat az ismereteket, melyek a kezelő biztonságát hivatottak garantálni a berendezés használata során. Részletes információk találhatóak a "Technical Information" című mellékletben.

E kézikönyv az alábbi megegyezésszerű jelöléseket alkalmazza:

VESZÉLY!



A veszélyt jelző üzenetek olyan eljárásra vagy specifikus tevékenységre hívják fel a kezelő figyelmét, melyek, ha nem megfelelő módon kerülnek végrehajtásra, súlyos személyi sérüléseket okozhatnak.

FIGYELEM!

A figyelmeztető üzenetek azon eljárások előtt kerülnek megjelenítésre, melyek figyelmen kívül hagyása a berendezés károsodásához vezethet.

MEGJEGYZÉS

A megjegyzések fontos, a szövegből kivonatolt információkat tartalmaznak.

Tárolás

A vezérlők szállítása és tárolása során az alábbi környezeti feltételeket kell biztosítani:

- hőmérséklet: -20 °C és +70 °C között
- relatív nedvességtartalom: 0 – 95 % (nem lecsapódó).

A telepítésre való előkészítés

A vezérlő speciális védőcsomagolásban kerül leszállításra; ha ez károsodás jeleit mutatja, melyek a szállítás során keletkezettek, kapcsolatba kell lépni a helyi forgalmazó irodával.

A kicsomagolás során különleges figyelmet kell fordítani arra, hogy a vezérlő le ne essék, és ne szenvedjen ütődéseket.

A csomagolóanyagot nem szabad szétszórni a környezetben. Az anyag teljes mértékben újrafelhasználható, s megfelel a környezetvédelemmel kapcsolatos EGK 85/399-es irányelvnek.

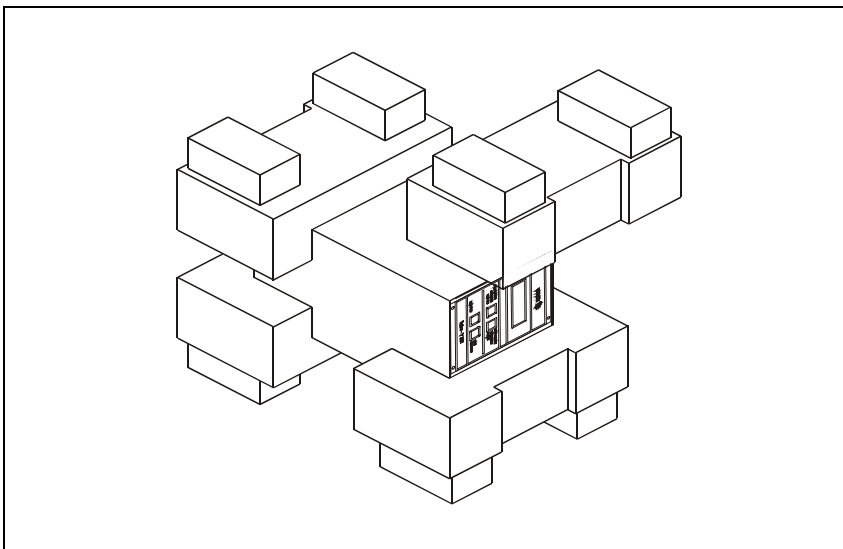

Ábra 1 A vezérlő csomagolása

Telepítés

VESZÉLY!



A vezérlő nemzetközileg jóváhagyott csatlakozódugóval ellátott, háromerű hálózati kábellel kell, hogy táplálva legyen (a rendelhető alkatrészeket lásd a táblázatban). Mindig ezt a hálózati kábelt kell használni, s a csatlakozódugót megfelelő földcsatlakozóval ellátott aljzatba illeszteni, az elektromos kiszülések elkerülése és az EK előírásainak a tiszteletben tartása érdekében. A vezérlő belsejében nagyfeszültségek alakulnak ki, melyek súlyos károkat vagy halált okozhatnak. A vezérlő bármely telepítési vagy karbantartási műveletének megkezdése előtt ki kell húzni a hálózati csatlakozót.

MEGJEGYZÉS

A vezérlő telepítésre kerülhet egy asztalon, vagy egy megfelelő rack belsejében. Minden esetben szükséges azonban, hogy a hűtőlevegő szabadon áramolhasson a berendezés belsejében. A vezérlőt nem szabad légköri hatásoknak (eső, fagy, hó) kitett, poros, maró hatású gázt tartalmazó, robbanás- vagy fokozottan tűzveszélyes környezetben telepíteni vagy használni.

Üzem közben az alábbi környezeti feltételeket kell biztosítani:

- hőmérséklet: +5 °C és +45 °C között;
- relatív nedvességtartalom: 0 – 95 % (nem lecsapódó).

A többi összekötéssel és az opcionális kiegészítő felszerelések telepítésével kapcsolatosan lásd a "Technical Information" című alfejezetet.

Használat

Ebben a szakaszban a fontosabb működési eljárások kerülnek ismertetésre. További részletek és az összekötéseket vagy az opcionális elemeket érintő eljárások találhatóak a "Technical Information" melléklet "Use" című szakaszában.

A vezérlő használata előtt valamennyi elektromos és pneumatikus összeköttetést létre kell hozni, és figyelembe kell venni a csatlakoztatott szivattyú kézikönyvét.

VESZÉLY!



Kérjük, beindítás előtt gondosan olvassa el a szóban forgó szivattyú kézikönyvét, a biztonságos használat érdekében.

MEGJEGYZÉS

A J1 lezáró csatlakozó össze kell maradjon kötve a megfelelő átkötéssel (jumper), ha nincs semmiféle külső összeköttetés. Az elő-vákuum és a TwisTorr szivattyú egyidejűleg is be lehetnek kapcsolva.

A vezérlő parancsai, kijelzői és csatlakozói

Az alábbiakban bemutatásra kerül a vezérlő elő- és hátlapja. További részletek találhatóak a “Technical Information” című szakaszban.

Az előlap leírása

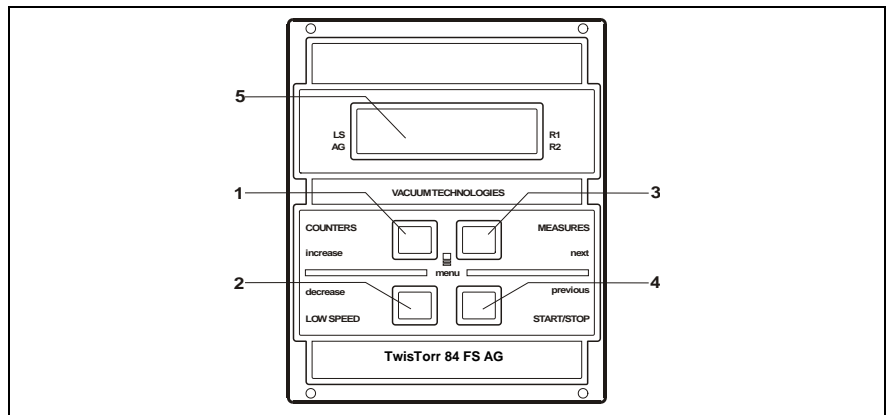

Ábra 2 A TwisTorr 84 FS AG számú vezérlő előlapja

1	Nyomógomb a paramétereknek: ciklusszám, ciklusidő, szivattyú élettartama, a kijelzőre való lehívására.
2	A LOW SPEED (kis sebesség) üzemmód kiválasztására szolgáló nyomógomb. Csak akkor aktív, amikor az előlapról a parancsmód ki lett választva. Egyszer megnyomva, a szivattyú “stand-by” sebességgel forog. Még egyszer megnyomva, a LOW SPEED mód kikapcsolásra kerül.
3	Nyomógomb a paramétereknek: szivattyúáram, a szivattyú hőmérséklete, szivattyúteljesítmény és a forgási sebesség kijelzőre való lehívására. Mindig aktív, függetlenül a kiválasztott üzemmódtól. A 3-as és 1-es nyomógombot együtt legalább 2 másodpercig nyomva tartva, egy program kerül aktiválásra, melynek segítségével néhány üzemi paraméter programozható.
4	Nyomógomb a START, STOP/RESET parancsok indítására. Csak akkor aktív, amikor az előlapról a parancsmód ki lett választva. Egyszer megnyomva az indítási fázis kerül aktiválásra; még egyszer megnyomva a szivattyú leállításra kerül. Ha a szivattyú valamely hiba következtében automatikusan leáll, ezt a nyomógombot kell megnyomni; az első megnyomásra a vezérlő nullázódik (reset), a másodikra a szivattyú újraindul.
5	Folyadékkristályos alfanumerikus kijelző: pontmátrixos, 2 sor x 16 karakter.

11 Felhasználói Kézikönyv

Használat

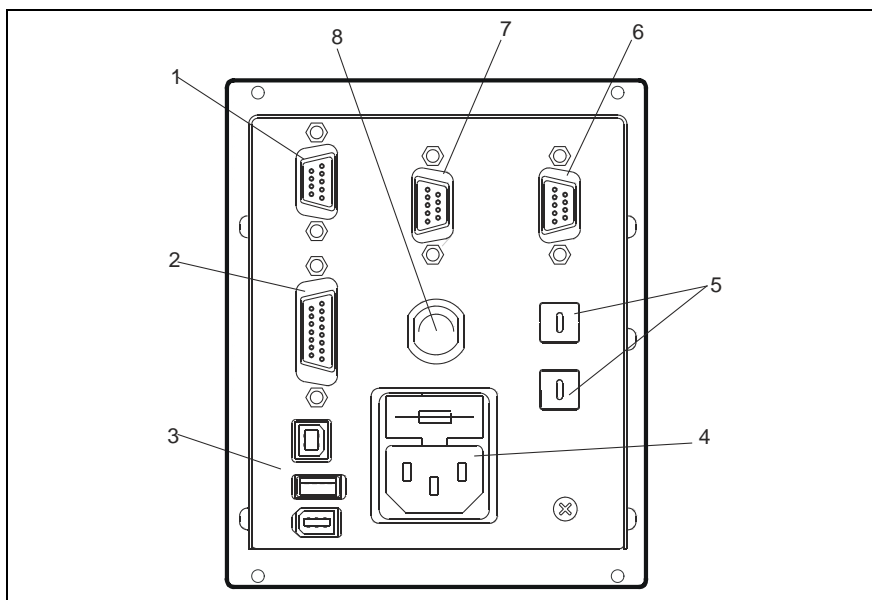

Ábra 3 A TwisTorr 84 FS AG számú vezérlők hátlapja

1	Logikai jelek bemeneti csatlakozója (az összekötő csatlakozó megfelelő lezáró átkötéssel (jumper) van ellátva).
2	Csatlakozó a kimeneti logikai jelek, a szivattyúfrekvencia ellenőrzése és programozható analóg kimenet számára.
3	Kimeneti tápcsatlakozó (24 Vdc szivattyú hűtőventillátor, légtelenítő szelep és idomszer).
4	Bementei tápellátó modul, a vezérlő számára. Magában foglalja a biztosítékokat, a tápcsatlakozót és az EMC- szűrőt.
5	Forgatógomb a Profibus címének beállításához (opcionális).
6	Profibus (opcionális).
7	Soros csatlakozó távvezérléshez.
8	Pumpakábel (hossza 5 méter).

Használati eljárások

A vezérlő bekapcsolása

A vezérlő bekapcsolásához elegendő a hálózati kábelt a hálózati aljzatba illeszteni.

A szivattyú beindítása

A szivattyú indításához, engedélyezze az interlock bemenetet (3-8 lábak rövidre zárása a P1-en) és nyomja meg a START gombot az előlapi vezérlőn.

A szivattyú leállítása

A szivattyú leállításához meg kell nyomni az előlapon található STOP nyomógombot.

Karbantartás

A TwisTorr 84 FS AG Rack sorozatú vezérlők semmiféle karbantartást sem igényelnek. Valamennyi beavatkozást meghatalmazott személyzet hajthat csak végre.

Meghibásodás esetén igénybe vehető a Agilent javítási szolgáltatása, vagy a "Agilent advanced exchange service", mely a meghibásodott helyett, egy javított vezérlőt biztosít.

VESZÉLY!



A vezérlőn való bármely beavatkozás végrehajtása előtt ki kell húzni a hálózati csatlakozót.

A vezérlőegység leselejtezésének szükségessége esetén, a megsemmisítés az erre vonatkozó nemzeti szabványok betartásával kell történjen.

Megsemmisítés

A címkén jelenlévő "WEEE" logo jelentése. Az alább látható szimbólum az EK "WEEE" elnevezésű irányelvével összhangban kerül alkalmazásra. Ez a szimbólum **(mely csak az Európai Közösség országaiban érvényes)**, azt jelzi, hogy a termék, melyen megtalálható, NEM kerülhet közönséges háztartási vagy ipari hulladékkal együtt megsemmisítésre, hanem azt egy szelektív hulladékgyűjtő rendszerbe kell továbbítani. A végfelhasználónak, a gyűjtési és megsemmisítési eljárás beindítása céljából, az adásvételi szerződés határidőinek és feltételeinek alapos áttanulmányozása után, fel kell vennie a kapcsolatot a berendezés szállítójával, legyen ez a gyártó vagy egy viszonteladó.



További információkért lásd:

<http://www.agilent.com/environment/product/index.shtml>

Hibaüzenetek

Ohjain määrittelee itse joitakin vikoja ja näyttää siinä tapauksessa seuraavanlaisia viestejä:

Tab. 1

ÜZENET	LEÍRÁS	JAVÍTÁSI TEVÉKENYSÉG
CHECK CONNECTION TO PUMP	Összeköttetési hiba a szivattyú és a vezérlő között, vagy a szivattyú hőmérséklete 0 °C alatt van.	Ellenőrizni, hogy a szivattyú és a vezérlő közti összekötő kábel mindkét végén jól van-e rögzítve és nincs e megszakadva. A szivattyú újraindításához kétszer megnyomni a START nyomógombot.
WAITING INTERLOCK	A P1 csatlakozó reteszelés jelen jele aktív a J1 csatlakozó 3. és 8. pin-je közti rövidzár megszakadása, vagy a külső reteszelő jel nyitott állapota következtében.	Kapcsolja össze a 3-as és 8-as lábakat a P1 csatlakozón, vagy zárja a külső interlock jelet.
PUMP OVERTEMP.	A felső csapágy vagy a szivattyú hőmérséklete meghaladta a 60 °C-t.	Várakozni, míg a hőmérséklet a küszöbérték alá esik. A szivattyú újraindításához kétszer megnyomni a START nyomógombot.
CONTROLLER OVERTEMP.	A vezérlő ának hőmérséklete túllépte a 70 °C-t, vagy a vezérlő hűtésének hőmérséklete túllépte a 60 °C-t.	Várakozni, míg a hőmérséklet a küszöbérték alá esik. A szivattyú újraindításához kétszer megnyomni a START nyomógombot.

11 Felhasználói Kézikönyv

Hibaüzenetek

ÜZENET	LEÍRÁS	JAVÍTÁSI TEVÉKENYSÉG
TOO HIGH LOAD	A szivattyú áramfelvétele túl nagy.	Ellenőrizni, hogy a szivattyú forgórésze szabadon foroghat-e. A szivattyú újraindításához kétszer megnyomni a START nyomógombot.
SHORT CIRCUIT	A szivattyú csatlakozója zárlatos.	Ellenőrizze az összeköttetést és rövidzárlatokat a szivattyú és a vezérlőegység között. A szivattyú újraindításához kétszer megnyomni a START nyomógombot.
SYSTEM OVERRIDE	A szivattyú leállt egy távérintkezőtől származó vészjel hatására.	Kihúzni a vezérlő hálózati csatlakozóját és megszüntetni a vészjelzés okát. Újra csatlakoztatni a hálózati kábelt, és kétszer megnyomni a START nyomógombot a szivattyú újraindításához.
OVERVOLTAGE	A vezérlő tápegység áramköre meghibásodott, vagy a vezérlő váratlanul túl nagy feszültséget kapott.	A szivattyú újraindításához kétszer megnyomni a START nyomógombot. Ha az üzenet ismétlődik, a Agilent-től karbantartási beavatkozást kérni.
POWER FAIL	Hiba a hálózati tápegységben.	A Agilent-től karbantartási beavatkozást kérni.

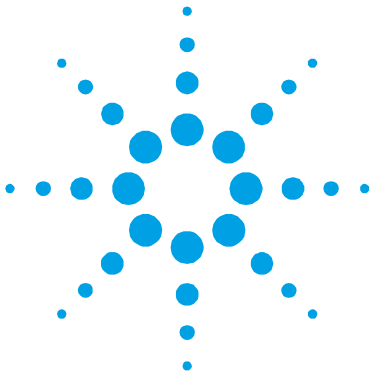

12 Podrecznik Instrukcji

Informacje ogólne	148
Magazynowanie	149
Przygotowanie do instalacji	150
Instalacja	151
Użytkowanie	152
Sterowniki, Wskazniki i Łączniki	153
Opis pulpitu frontального	153
Procedure użytkowania	155
Zaswiecenie kontrolera	155
Uruchomienie pompy	155
Zatrzymanie pompy	155
Konserwacja	155
Przetworstwo odpadów	156
Błędne informacje	156

Az eredeti utasítás fordítása



Informacje ogólne

Urządzenie to jest przeznaczone do użytku zawodowego. Przed przystąpieniem do korzystania użytkownik powinien wnikliwie przesledzić zarówno ten podręcznik zawierający instrukcje jak również każda inna dostarczona przez Agilent informację. Agilent uchyli się od jakiegokolwiek odpowiedzialności w przypadku całkowitego lub częściowego nie przestrzegania swoich instrukcji, przeznaczenia urządzenia niezgodnie z jego przeznaczeniem i jego obsługi przez personel uprzednio nie przeszkolony, naprawy urządzenia bez odpowiedniej autoryzacji lub przeznaczenia niezgodnego z obowiązującymi, specyficznymi normami krajowymi. Kontrolery z serii TwisTorr 84 FS AG Rack są przetwornikami częstotliwości kontrolowanymi przez mikroprocesor zrealizowanymi z komponentów w stanie stałym i posiadającymi zdolności samodiagnostyczne i samoochronne.

Dane kontrolera:

- Operatywny frontalnie / w izolacji / seryjnie
- Sterowanie turbiny chłodzenia pompy z szybkością 24 Vdc
- Sterowanie vent valve
- Odczyt szybkości pracy pompy w momencie nakazu zatrzymania (odczyt szybkości w momencie zatrzymania)
- Odczyt ciśnienia
- Posrednik Profibus (dodatkowy)
- Automatyczne ustawienie napięcia wejściowego.

W następnych paragrafach zawarte są wszystkie niezbędne informacje dotyczące gwarancji bezpieczeństwa personelu obsługującego urządzenie.

Bardziej szczegółowe informacje są zawarte w dodatku do "Technical Information".

Podrecznik ten opiera sie na nastepujacych konwencjach:

ZAGROZENIE!



Sygnaly ostrzegajace o zagrozeniu powinny zwrocic uwage operatora na odpowiednia specyficzna procedure ktora jezeli nie jest przestrzegana w sposob prawidlowy moze przyczynic sie do powaznych obrazen osoby obsługujacej.

UWAGA!

Sygnaly wzrokowe ukazujace sie przed procedura jezeli zostana zlekcewazone moga spowodowac uszkodzenia urzadzenia..

PRZYPIS

Przypisy zawieraja najwazniejsze informacje wyciagniete z tekstu.

Magazynowanie

Kontrolery podczas transportu i przechowywania w magazynie powinny miec nastepujace warunki otoczenia:

- temperatura: od -20 °C do +70 °C
- wilgotnosc wzgledna: od 0-95 %(nie kondensujaca).

Przygotowanie do instalacji

Kontroler zostaje dostarczony w specjalnym, ochronnym opakowaniu; jeżeli opakowanie prezentuje jakiegokolwiek uszkodzenia które mogłyby powstać podczas transportu wówczas należy niezwłocznie powiadomić najbliższy, lokalny punkt sprzedaży.

Podczas operacji rozpakowywania należy zachować specjalną ostrożność żeby nie spowodować upadku kontrolera lub nie narazić na uderzenia.

Nie wyrzucać opakowania ponieważ jest ono całkowicie recyklowalne i odpowiada normom CEE 85/399 dotyczącym ochrony środowiska.

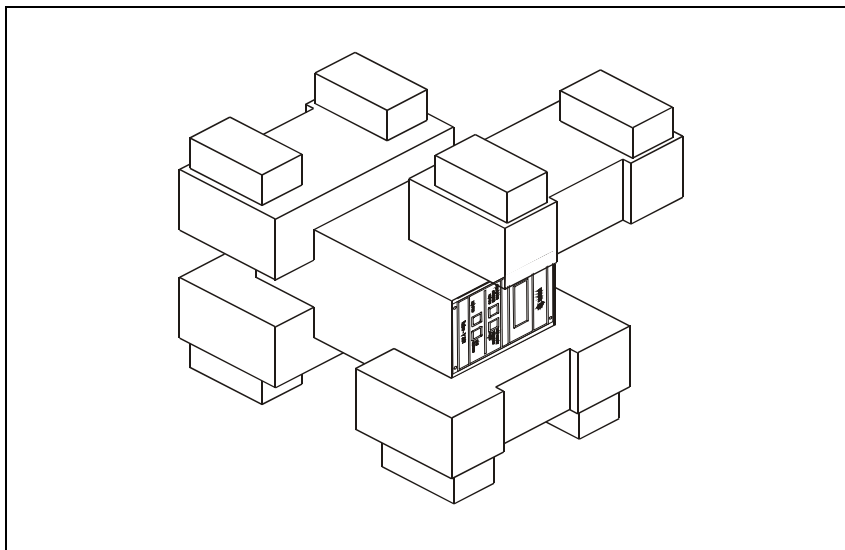

Postać 1 Opakowanie kontrolera

Instalacja

ZAGROZENIE!



Kontroler jest zasilany przy użyciu kabla składającego się z trzech przewodów (patrz tabela części na zamówienie) i rodzaju wtyczki odpowiadającej standardom międzynarodowym gwarantującego bezpieczne użytkowanie. Należy wyłącznie używać tego rodzaju kabla zasilającego i włączac wtyczkę do gniazdka odpowiadającego przepisom Unii Europejskiej tzn. posiadającego połączenie z masą celem wykluczenia iskrzen. We wnętrzu kontrolera powstają wysokie napięcia które mogą być przyczyną poważnych obrażeń lub wypadków śmiertelnych. Przed przystąpieniem do jakiegokolwiek operacji instalowania lub konserwacji należy odłączyć go od źródła zasilania.

PRZYPIS

Kontroler może być zainstalowany na stole lub wewnątrz odpowiedniego Rack. W obydwu przypadkach należy pamiętać aby wokół kontrolera zapewnić swobodny przepływ powietrza dla prawidłowego chłodzenia. Nie instalować i/lub użytkować kontrolerów w miejscach narażonych na działanie warunków atmosferycznych (jak deszcz, mroz, śnieg), pyłów, gazów agresywnych w środowisku wybuchowym lub o dużym stopniu zagrożenia pożarowego.

Podczas pracy kontrolera należy zapewnić następujące warunki otoczenia:

- temperatura: od +5 °C do +45 °C
- wilgotność względna: 0 – 95 % (nie kondensująca).

Sposób połączenia i instalowania akcesoriów jest opisany w rozdziale "Technical Information".

Użytkowanie

Paragraf ten zawiera podstawowe procedury operatywne. Dla uzyskania dodatkowych bardziej szczegółowych informacji lub dostępu do procedur na temat połączeń lub akcesoriów skonsultować paragraf "Use" znajdujący się w dodatku do "Technical Information".

Przed przystąpieniem do użytkowania kontrolera wykonać wszystkie połączenia elektryczne i pneumatyczne podłączenie pompy konsultować z odnosną instrukcją.

ZAGROZENIE!



Aby obsługiwać pompę w bezpieczny sposób, należy zapoznać się z odpowiednią instrukcją obsługi.

PRZYPIS

W przypadku kiedy nie zostanie wykonane żadne połączenie zewnętrzne łącznik zamykający J1 powinien pozostać połączony ze swoim mostkiem. Pompa wstępnej próżni i pompa TwisTorr mogą być uruchomione jednocześnie.

Sterowniki, Wskazniki I Laczniki

Ponizsze rysunki przedstawiaja panel frontalny i tylny kontrolera. Dla uzyskania dokladniejszych szczegolow skonsultowac odpowiedni rozdzial "Technical Information".

Opis pulpitu frontalnego

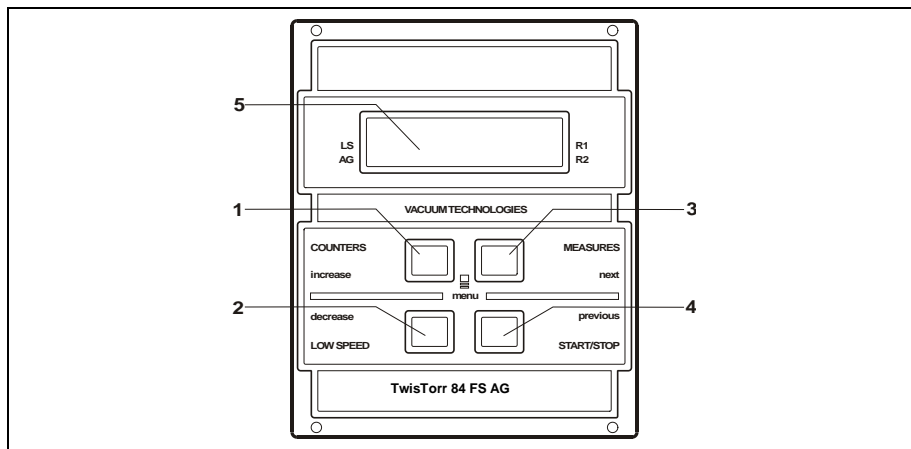

Postać 2 Pulpit frontálny kontrolera TwisTorr 84 FS AG

1	Przycisk sluzacy do przywołania na display parametrow cycle number, cycle time I pump life.
2	Przycisk do wybierania sposobu LOW SPEED. Dziala tylko wtedy kiedy sposob sterowania jest wybierany na pulpicie frontalnym. Naciskajac jeden, szybkość obrotu pompy w pozycji "stand-by". Naciskajac jponownie następuje wyłączenie sposobu LOW SPEED ponownie.
3	Przycisk sluzacy do przywołania na display parametrow "pump current", "pump temperature", "pump power" I "rotational speed". Jest zawsze aktywny niezaleznie od wybranego sposobu dzialania. Naciskajac jednoczesnie przyciski 3 I 1 przez conajmniej 2 sekundy uruchamia sie program przy pomocy ktorego jest mozliwe programowanie niektorych parametrow operatywnych.
4	Przycisk do przesyłania sygnalu START, STOP/ RESET. Dziala tylko wtedy kiedy sposob sterowania jest wybierany na pulpicie frontalnym naciskajac jeden raz uaktywnia sie faza uruchomienia; naciskajac ponownie zatrzymuje sie pompe. Jezeli pompa zatrzyma sie automatycznie z powodu uszkodzenia nalezy nacisnac przycisk jeden raz zeby zresetowac kontrolera I poraz drugi zeby uruchomic pompe.
5	Display alfanumeryczny na cieklych krysztalach: matryca punktowana, 2 linie x 16 czcionek.

12 Podrecznik Instrukcji Uzytkowanie

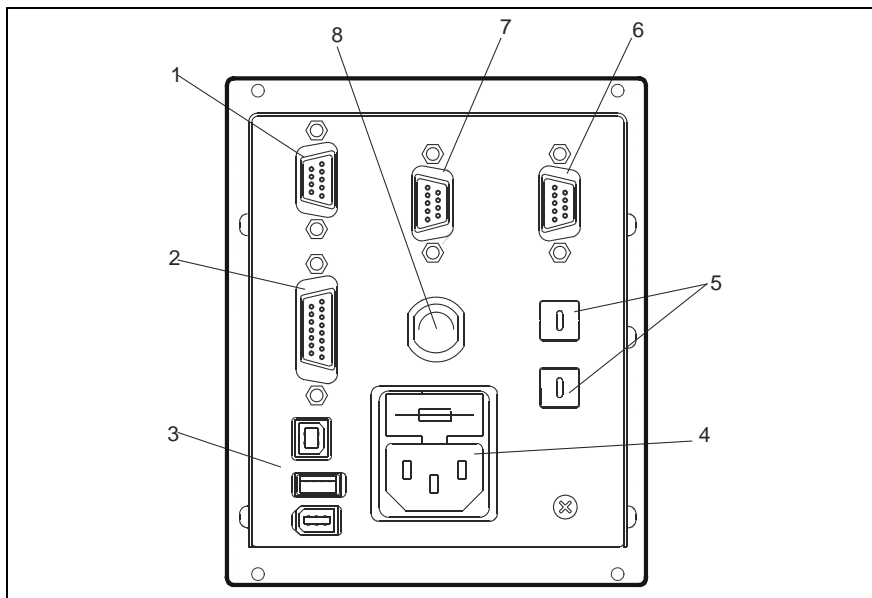

Postać 3 Pulpit tylny kontrolerow TwisTorr 84 FS AG

1	Lacznik wejsciowy sygnalow logicznych (lacznik blizniaczy jest dostarczany z specjalnym mostkiem zamykajacym).
2	Lacznik wyjsciowy sygnalow logicznych i nadzor nad czestotlowoscia na wyjsciu podczas zaprogramowanej, wielokrotnej pracy pompy.
3	Lacznik zasilania na wyjsciu (24 Vdc dla turbiny chlodzacej pompy, zawor odpowietrzajacy i wskaznik).
4	Modul wejsciowy zasilania kontrolera zawierajacy bezpieczniki topikowe, gniazdko zasilajace i filtr ENC.
5	Switch obrotowy do ustawiania kierunku Profibus.
6	Profibus (dodatkowy).
7	Lacznik seryjny do kontroli na odleglosc.
8	Kabel pompy (dlugosc 5 m)

Procedure uzytkowania

Zaswiecenie kontrolera

Do zaswiecenia kontrolera wystarczy wprowadzic kabel zasilajacy do gniazdka sieci.

Uruchomienie pompy

Aby uruchomic pompe, nalezy potwierdzic uruchomienie blokady (zwieranie styków 3÷8 na P1), a nastepnie nacisnac na przycisk START na przednim panelu sterownika.

Zatrzymanie pompy

Do zatrzymania pompy wystarczy nacisnac przycisk STOP znajdujacy sie na pulpicie frontalnym.

Konserwacja

Kontroler z serii TwisTorr 84 FS AG Rack nie wymaga zadnej konserwacji. Jakakolwiek interwencja moze byc dokonywana wylacznie przez osoby autoryzowane.

W przypadku uszkodzenia mozliwe jest korzystanie z serwisow naprawczych Agilent lub "Agilent advance exchange service", w ktorym mozna otrzymac kontroler zregenerowany zastepujac go tym uszkodzonym.

ZAGROZENIE!



Przed wykonaniem jakiegokolwiek interwencji na kontrolerze nalezy odlaczyc kabel zasilajacy.

W przypadku konieczności złomowania urządzenia sterującego, należy się go pozbyć zgodnie z normami krajowymi.

Przetworstwo odpadów

Objasnienie znajdującego się na etykiecie znaczenia logo “WEEE”.
Użyty poniżej symbol jest zgodny z wymogiem zarządzenia “WEEE” Unii Europejskiej. Symbol ten (**prawomocny tylko w krajach Unii Europejskiej**) oznacza, że wyrob który nim został oznaczony NIE może być przetworzony jako odpad razem z innymi domowymi lub przemysłowymi natomiast musi być składowany w miejscu przeznaczonym dla odpadów do przerobki zroznicowanej . Dlatego też poleca się użytkownikowi, , po uprzedniej weryfikacji terminu i warunków zawartych w kontrakcie sprzedaży, nawiązać kontakt z dostawcą lub sprzedawcą urządzenia w celu uruchomienia procesu zbiórki i przerobu.



Aby uzyskać więcej informacji, patrz:

<http://www.agilent.com/environment/product/index.shtml>

Bledne informacje

Sterownik sam zdiagnozuje niektóre przyczyny błędów i wyświetli następujące komunikaty:

Tab. 1

INFORMACJA	OPIS	AKCJA KORYGUJACA
CHECK CONNECTION TO PUMP	Zakłocenia na połączeniu między pompa i kontrolerem. Lub Temperatura pompy jest poniżej 0 °C.	Zweryfikować czy kabel łączący pompę z kontrolerem jest dobrze zamocowany na obydwu końcach i czy nie jest przerwany. Nacisnąć dwa razy przycisk START dla ponownego uruchomienia pompy.
WAITING INTERLOCK	Jest aktywny sygnał Interlock na lączniku P1 spowodowany zwarcie między pin 3 i pin 8 lącznika J1, Lub na skutek otwarcia sygnału zewnętrznego interlock.	Połączyć pin 3 ze pin 8 złącza P1, lub zamknąć zewnętrzny sygnał blokady.
PUMP OVERTEMP.	Temperatura górnego łożyska lub pompy przekroczyła 60 °C.	Odczekać aż temperatura się obniży poniżej ustalonego poziomu. Nacisnąć dwa razy przycisk START dla ponownego uruchomienia pompy.
CONTROLLER OVERTEMP.	Temperatura w kontrolerze przekroczyła 70 °C. Lub Temperatura grzejnika nie przekracza 60 °C.	Odczekać aż temperatura się obniży poniżej ustalonego poziomu. Nacisnąć dwa razy przycisk START dla ponownego uruchomienia pompy.

12 Podrecznik Instrukcji

Bledne informacje

INFORMACJA	OPIS	AKCJA KORYGUJACA
TOO HIGH LOAD	Prąd pobierany przez pompę jest zbyt wysoki.	Sprawdź czy wirnik nie ma przeszkód w swobodnym obrocie. Nacisnąć dwa razy przycisk START dla ponownego uruchomienia pompy.
SHORT CIRCUIT	Na złączu pompy występuje zwarcie.	Należy sprawdzić połączenia i zwarcia pomiędzy pompą a sterownikiem. Nacisnąć dwa razy przycisk START dla ponownego uruchomienia pompy.
SYSTEM OVERRIDE	Pompa się zatrzymała na skutek sygnału zagrożenia pochodzącego od pierwotnego kontaktu.	Odlączyć kabel zasilania kontrolera i sprawdzić przyczynę powstania sygnału zagrożenia. Podłączyć ponownie kabel zasilający i nacisnąć dwa razy przycisk START dla ponownego uruchomienia pompy.
OVERVOLTAGE	Zasilanie urządzenia sterującego zespołu obwodów elektrycznych jest wadliwe lub nastąpiła niespodziewana dostawa nadmiernego napięcia do sterownika.	Nacisnąć dwa razy przycisk START dla ponownego uruchomienia pompy. Jeżeli sygnał się powtórzy zwrócić się do Agilent o przeprowadzenie konserwacji.
POWER FAIL	Awaria w sekcji zasilania.	Zwrócić się do Agilent w celu naprawy.

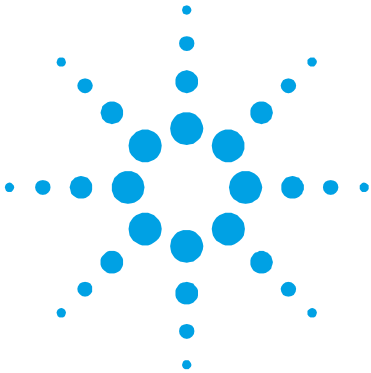

13 Návod k Použití

Všeobecné informace	160
Uskladnění	161
Příprava k instalaci	162
Instalace	163
Použití	164
Ovládání, indikátory a konektory	165
Popis čelního panelu	165
Používané procedury	167
Zapalování Kontroléru	167
Spouštění čerpadla	167
Zastavení čerpadla	167
Údržba	167
Likvidace	168
Chybné zprávy	168

Překlad originálního návodu



Všeobecné informace

Tento přístroj je určen pro profesionální potřebu. Uživatel si musí před použitím tuto příručku velmi pozorně přečíst, ale i každou další aktualizaci, kterou podnik bude předávat. V důsledku nedostatečného i částečně nesprávného použití, nebo v případě chyb nevyškoleného personálu či neoprávněných zásahů a neodpovídajících specifickým státním normám, Agilent nepřijímá a nenese žádnou zodpovědnost. Kontroléry série TwisTorr 84 FS AG Rack jsou frekvenčními konvertory, jsou kontrolovány mikroprocesorem a skládají se z pevných komponentů s autodiagnostickou a samoochrannou schopností.

Charakteristiky kontroléru:

- Čelní operativnost / dálková / seriální.
- Pilotáž o 24 Vdc ochlazovací lopatky čerpadla. Pilotáž vent valve.
- Čtení rychlosti čerpadla po příkazu zastavení (čtení rychlosti zastavení).
- Čtení tlaku.
- Rozhraní Profibus (opční).
- Automatické nastavení vstupního napětí.

V následujících odstavcích jsou uvedeny veškeré nutné informace, týkající se operátora a bezpečnostních podmínek během provozu přístroje. Detailní informace se nacházejí v dodatku "Technical Information".

Tato příručka používá následující označení:

NEBEZPEČÍ!



Odkazy, které upozorňují na nebezpečí a donutí operátora, aby se řídil dle procedury nebo specifické praktiky, která nebude-li řádně vykonána, může ohrozit vážným způsobem jeho zdraví.

POZOR!

Tyto zprávy bývají vizualizovány před jakoukoliv procedurou, je třeba se jimi řídit, aby nedošlo k poškození přístroje.

POZNÁMKA

Poznámky, vyjmuté z textu obsahují velmi důležité informace.

Uskladnění

Během dopravy a skladování kontrolérů, se musí dbát na následující podmínky prostředí:

- teplota: od -20 °C do +70 °C
- relativní vlhkost: 0 – 95 % (nesmí kondenzovat).

Příprava k instalaci

Kontrolér je dodáván v speciálním ochranném balení; objeví-li se následkem dopravy nějaké poškození, je třeba se okamžitě obrátit na místní prodejní servis. Během rozbalování se obzvlášť musí dávat pozor, aby kontrolér nespadol nebo aby neutrpěl nárazy. Balicí materiál se nesmí odkládat v přírodě. Tento materiál se může kompletně recyklovat, neboť se shoduje se směrnicemi EU, CEE 85/399, které se týkají životního prostředí.

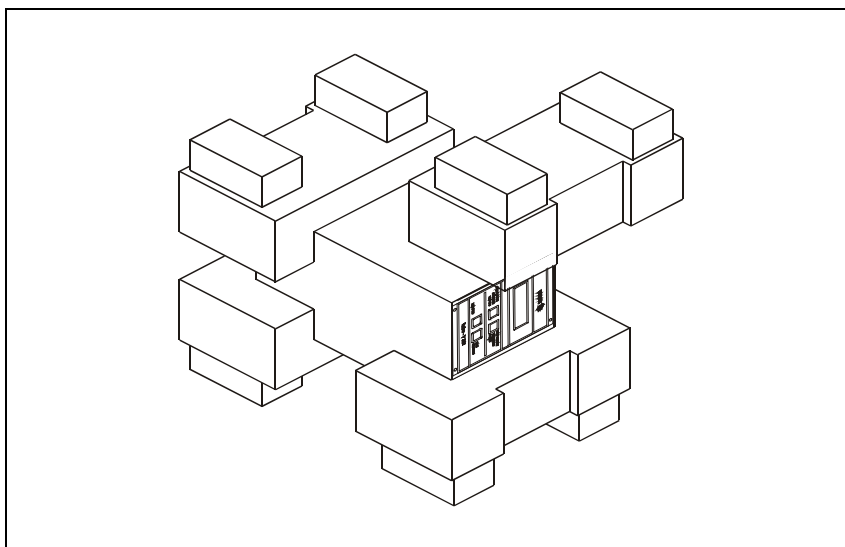

Postava 1 Obal kontroléru

Instalace

NEBEZPEČÍ!



Kontrolér musí být napájen třídrátovým kabelem (viz tabulku součástí, které lze objednat) se zástrčkou shodnou s mezinárodním standardem, která zaručuje bezpečnost uživatele. Výše uvedený kabel je třeba neustále používat, zástrčku zasunovat do zásuvky s adekvátně uzeměným spojením, aby se předešlo elektrickým výbojům a aby se respektovaly směrnice CE. Uvnitř kontroléru dochází k vysokým napětím, která jsou velmi nebezpečná i smrtící. Před provedením jakékoliv instalační či údržbové práce na kontroléru, je třeba ho odpojit od příkonu.

POZNÁMKA

Kontrolér může být nainstalován na stole nebo uvnitř příslušného rack. V každém případě je třeba, aby okolo přístroje mohl vzduch volně proudit. Kontrolér se nesmí instalovat v místech vystavených atmosferickým vlivům (déšť, mráz, sníh), prachu, agresivním plynům, na výbušných místech nebo na místech kde existuje velké riziko požárů.

Během provozu je třeba, aby se respektovaly následující podmínky, týkající se operativního prostředí:

- teplota: od 5 °C do +45 °C
- Relativní vlhkost: 0 – 95 % (nesmí kondenzovat).

Pro další spojení a instalaci opčního příslušenství je třeba se podívat do sekce "Technical Information".

Použití

V tomto odstavci jsou uvedeny hlavní operativní postupy. Pro další detaily i pro procedury týkající se spojení nebo dalších opčních detailů, je třeba se obracet na odstavec "Use" v příloze "Technical Information". Veškerá elektrická a pneumatická spojení se musí vykonat před použitím kontroléru, při čemž je třeba se obracet na příslušnou příručku napojeného čerpadla.

NEBEZPEČÍ!

Před spuštěním se pro bezpečný provoz obraťte na příslušný manuál k pumpě.

POZNÁMKA

Uzavírající konektor J1, jestliže nebude uskutečněno žádné vnější spojení, musí zůstat propojený se svým můstkem. Čerpadla pre-prázdná a TwisTorr se mohou zapnout současně.

Ovládání, indikátory a konektory

V následujícím je ukázán čelní a zadní panel kontroléru. Pro širší detaily je třeba se obrátit na sekci "Technical Information".

Popis čelního panelu

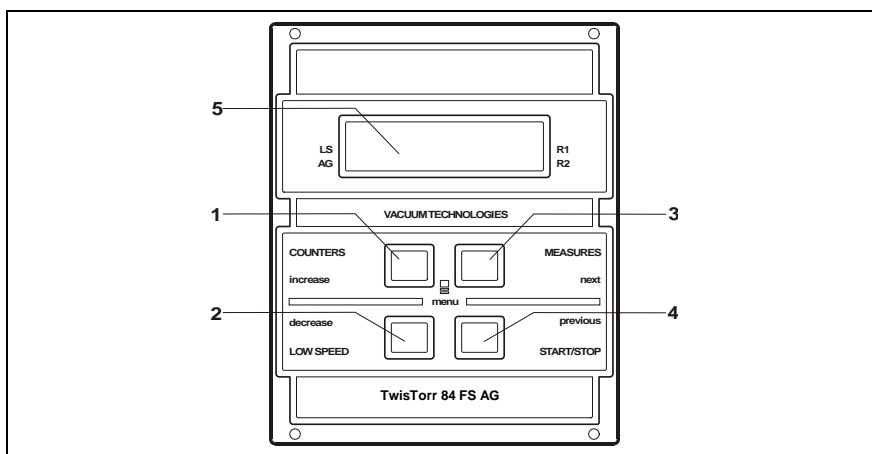

Postava 2 Čelní panel Konroléru TwisTorr 84 FS AG

1	Tlačítko přivolaných parametrů na displeji: cycle number, cycle time a pump life.
2	Tlačítko na volbu způsobem LOW SPEED. Je aktivní jen při zvoleném způsobu ovládání z čelního panelu. Stiskne-li se jen jednou, čerpadlo pracuje rychlostí "stand-by". A stiskne-li se ještě jednou, deaktivuje se způsob LOW SPEED.
3	Tlačítko na přivolání parametrů na displeji: "pump current", "pump power", "rotational speed", temperatura spodního ložiska, temperatura vrchního ložiska, temperatura motoru, frekvence indukce. Nezávisle od zvoleného provozního způsobu, je neustále aktivní. Jestliže se tlačítka 3 a 1 stisknou společně alespoň na 2 vteřiny, bude aktivován program, dle kterého se mohou naprogramovat některé operativní parametry.
4	Tlačítko ovládání START, STOP/RESET. Je aktivním jen po volbě na čelním panelu. Stiskne-li se jen jednou, spouštěcí fáze bude aktivována; jestliže se znovu stiskne, čerpadlo se zastaví. Jestliže se čerpadlo automaticky zastaví z důvodu nějaké poruchy, tlačítko se musí napoprvé stisknout, aby se uskutečnil reset kontroléru a po druhé aby se čerpadlo znovu spustilo.
5	Alfanumerický displej na tekuté krystaly: matice bodů, 2 linky x 16 charakterů.

13 Návod k Použití

Použití

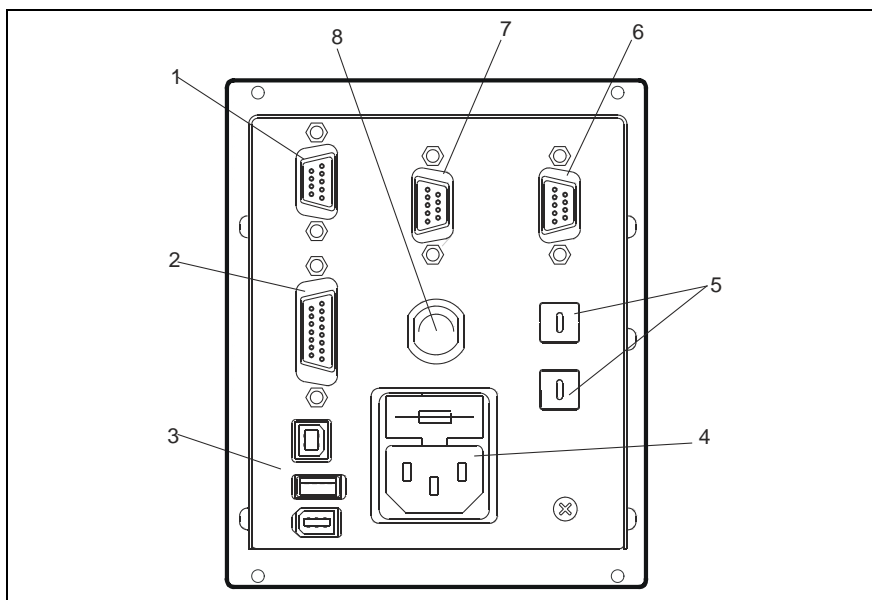

Postava 3 Zadní panel Kontroléru TwisTorr 84 FS AG

1	Vstupní konektor logických signálů (konektor spojky je dodáván s příslušným znovu zavírajícím můstkem).
2	Konektor výstupních logických signálů a monitorování frekvence čerpadla plus naprogramovatelný analogový výstup.
3	Konektor výstupu napájení (24 Vdc na ochlazovací lopatku čerpadla, odvzdušňovací ventil a vakuoměr).
4	Vstupní napájecí modul kontroléru, který zahrnuje i tavné pojistky, napájecí zásuvku a filtr ENC.
5	Rotační switch na stanovení Profibusové adresy (opční).
6	Profibus (opční).
7	Seriální konektor na dálkovou kontrolu.
8	Kabel pumpy (délka 5 m).

Používané procedury

Zapalování Kontroléru

Kontrolér se zapne vložením kabele do zásuvky na síti.

Spouštění čerpadla

Pro zapnutí pumpy zkontrolujte vstup propojení (zkratovací svorkovnice 3÷8 na P1) a zmáčkněte tlačítko START na předním panelu ovladače.

Zastavení čerpadla

Čerpadlo se zastaví stisknutím tlačítka STOP na čelním panelu.

Údržba

Kontrolér série TwisTorr 84 FS AG Rack nevyžadují žádnou údržbu. Jakýkoliv zásah musí být vykonáván jen oprávněným personálem.

V případě poruchy se může využít opravářského servisu Agilent nebo "Agilent advanced exchange service", kde poškozený kontrolér bude vyměněn za nový.

NEBEZPEČÍ!



Nejdříve, před jakýmkoliv zásahem na kontroléru, se musí odpojit elektrický kabel.

Pokud má být vyřazen ovladač, musí být vyřazen v souladu se specifickými národními normami.

Likvidace

Význam loga "WEEE" nacházejícího se na štítku. Níže uvedený symbol odpovídá směrnici CE pojmenovaným "WEEE". Tento symbol (**platný jen pro státy Evropské Unie**) určuje, že výrobek, který je takto označen NESMÍ být likvidován společně s ostatními domácími nebo průmyslovými odpady, ale je nutno ho předat do příslušných provozních sběrů, kde musí být tříděn a likvidován odděleně od městského odpadu. Uživatel, který má výrobek likvidovat doporučujeme, aby se nakontaktoval přímo s výrobcem nebo prodejcem, který se po příslušném prověření termínů a smluvních podmínek postará o kompletní likvidaci uvedeného výrobku.



Více informací naleznete na:

<http://www.agilent.com/environment/product/index.shtml>

Chybné zprávy

Ovladač sebe-diagnostikuje některé příčiny chyb a zobrazí následující zprávy:

Tab. 1

ZPRÁVY	POPIS	KOREKCE
CHECK CONNECTION TO PUMP	Chybné fungování spojení mezi čerpadlem a kontrolérem (P31). Nebo Čerpadlo má nižší teplotu než je 0 °C.	Provéřit zda kabelové spojení mezi pumpou a kontrolérem je správně upevněné na obou dvou koncích a že nedošlo k přerušení. Stisknout tlačítko START dvakrát pro opětné spuštění čerpadla.
WAITING INTERLOCK	Aktivní signál interlock se nachází na konektoru P1, neboť došlo k přerušení zkratu mezi pin 3 a pin 8 del konektoru J1, nebo kvůli otevření signálu vnějšího interlock.	Připojte pin 3 ke pin 8 konektoru P1 nebo uzavřete externí propojovací signál.
PUMP OVERTEMP.	Teplota horního ložiska nebo čerpadla převýšila 60 °C.	Počkat až se teplota opět vrátí pod mezní hodnotu. Stisknout dvakrát tlačítko START pro opětné spuštění čerpadla.
CONTROLLER OVERTEMP.	Teplota kontroléru převýšila 70 °C. Nebo Teplota radiátoru kontroléru je vyšší než 60 °C.	Vyčkat až se teplota opět vrátí pod mezní hodnotu. Stisknout dvakrát tlačítko START pro opětné spuštění čerpadla.

13 Návod k Použití

Chybné zprávy

ZPRÁVY	POPIS	KOREKCE
TOO HIGH LOAD	Proud čerpaný pumpou je příliš vysoký.	Prověřit, zda rotor čerpadla se může volně otáčet. Stisknout dvakrát tlačítko START pro opětné spuštění čerpadla.
SHORT CIRCUIT	Na konektoru pumpy je zkrat.	Zkontrolujte zapojení a zkratky mezi pumpou a ovladačem. Stisknout dvakrát tlačítko START pro opětné spuštění čerpadla.
SYSTEM OVERRIDE	Pumpa byla zastavena nouzovým signálem prostřednictvím dálkového kontaktu.	Odpojit napájecí kabel kontroléru a napravit příčinu poplachu. Znovu připojit napájecí kabel a stisknout dvakrát tlačítko START pro opětné spuštění čerpadla.
OVERVOLTAGE	Obvody zdroje ovladače jsou vadné nebo ovladač obdržel nečekané nadbytečné napětí.	Stisknout dvakrát tlačítko START pro opětné spuštění čerpadla. Po opětné zprávě ohledně údržby je nutno se obrátit na Agilent .
POWER FAIL	Selhání v sekci zdroje energie.	Ohledně údržby je třeba se obrátit na Agilent.

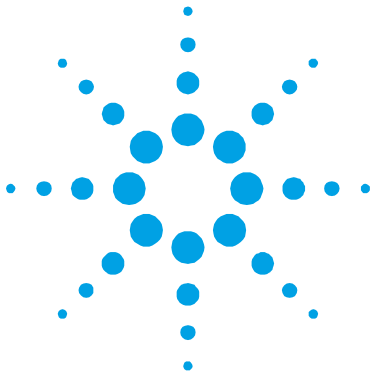

14 Návod na Obsluhu

Všeobecné informácie	172
Uskladňovanie	173
Príprava pre inštaláciu	174
Inštalácia	175
Použitie	176
Povely, Ukazovatele a Prípojky "Controller"	177
Popis čelného panelu	177
Postup pri použití	179
Zapnutie "Controller"	179
Naštartovanie čerpadla	179
Zastavenie čerpadla	179
Údržba	179
Likvidácia	180
Oznamy väd	180

Preklad originálneho návodu



Všeobecné informácie

Tento prístroj slúži k profesionálnemu použitiu. Užívateľ si pred použitím tohto prístroja musí pozorne prečítať tento návod k použitiu a jeho ďalšie doplnky, dodané podnikom Agilent. Podnik Agilent nepreberá na seba žiadnu zodpovednosť za úplné, alebo čiastočné nedodržiavanie návodu, za nesprávne používanie prístroja nekompetentnými osobami, za nepovolené zásahy a za používanie, ktoré nie je v zhode s príslušnými národnými normami. "Controllers" série TwisTorr 84 FS AG Rack sú meniči kmitočtu, kontrolované mikroprocesorom, vyrobené prvkami pevnej fázy a so schopnosťou samodiagnostiky a samokontroly.

Charakteristiky controller-a:

- Čelné / diaľkové / sériové riadenie
- 24 Vdc riadenie chladiacej lopatky čerpadla
- Riadenie vent valve
- Čítanie rýchlosti čerpadla po povelí zastavenia (čítanie rýchlosti zastavenia)
- Čítanie tlaku
- Medzičlánok Profibus (na objednávku)
- Automatické nastavenie vstupného napätia.

Ďalej sú popísané všetky potrebné informácie, ktorých úlohou je zabezpečiť bezpečnosť pracovníka počas používania prístroja.

Podrobné informácie sú uvedené v dodatku "Technical Information".

Tento návod používa nasledujúce signály:

NEBEZPEČIE!



Signál nebezpečie upozorňuje pracovníka na určitý pracovný postup, ktorý, keď nie je prevedený správne, môže zapríčiniť vážne osobné poranenia.

POZOR!

Signály “pozor” sú pred tými postupmi, ktoré, v prípade ich nedodržania, môžu poškodiť prístroj.

POZNÁMKA

Poznámky zahrňujú dôležité informácie, vyťahnuté z textu.

Uskladňovanie

Počas prepravy a uskladňovania “Controllers” musia byť dodržané tieto podmienky prostredia:

- teplota: od -20 °C do +70 °C
- relatívna vlhkosť: 0 – 95 % (bez kondenzátu).

Príprava pre inštaláciu

“Controller” je dodaný v špeciálnom ochrannom obale; keby ste objavili škodu, spôsobenú prepravou, skontaktujte sa s kanceláriou miestneho predaja.

Pri rozbaľovaní dávajte pozor, aby vám “Controller” nespadol, alebo niekde nenarazil. Obal nezahadzujte. Je vyrobený z recyklovateľného materiálu a zodpovedá smernici CEE 85/399 pre ochranu životného prostredia.

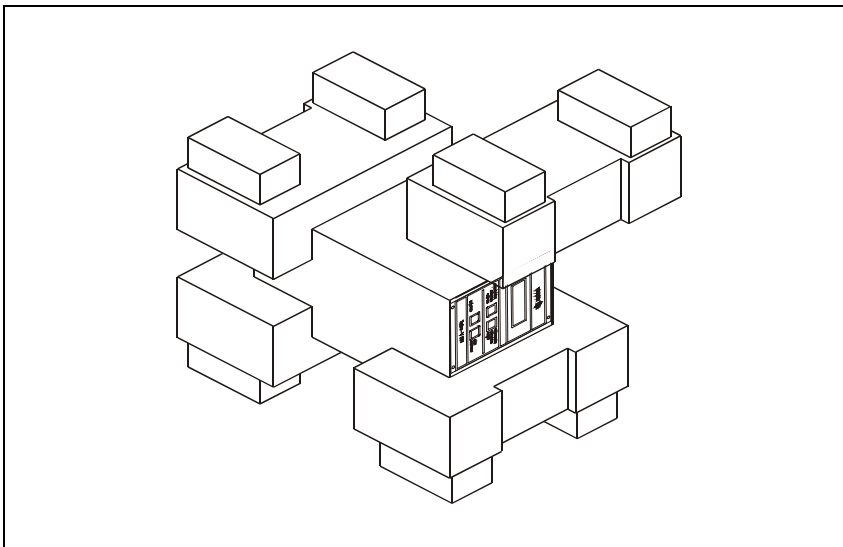

Postava 1 Obal Controller

Inštalácia

NEBEZPEČIE!



Controller musí byť napojený na sieť s trojdôtovým napájacím káblom (vid' tabuľku objednávajúcich súčiastok) so zástrčkou, ktorá zodpovedá medzinárodnej úrovni a tak zabezpečuje bezpečnosť užívateľa. Používajte výhradne tento napájací kábel a zástrčku zasúvajte do zástrčky, ktorá má vhodné uzemnenie, aby ste sa vyhli elektrickému výboju. Táto musí rešpektovať stanovenia EÚ. Vo vnútri "controller" sa vytvára vysoké napätie, ktoré môže spôsobiť vážne škody alebo smrť. Pred akýmkoľvek úkonom, týkajúceho sa inštalácie alebo údržby "controller-a" nezabudnite vytiahnuť zástrčku z elektrickej zásuvky.

POZNÁMKA

"Controller" môže byť inštalovaný na pracovnom stole alebo vo vnútri rack. V každom prípade je potrebné, aby chladiaci vzduch mohol voľne krúžiť okolo prístroja. "Controller" nepoužívajte a neinštalujte v prostredí, vystavenom atmosferickým vplyvom (dážď, mráz, sneh), prachu, agresívnym plynom a v prostredí s vysokým rizikom požiaru.

Počas chodu je dôležité, aby boli rešpektované tieto podmienky prostredia:

- teplota: od +5 °C do +45 °C;
- relatívna vlhkosť: 0 – 95 % (nekondenzovaná).

Pre ostatné napojenia a inštaláciu zvoliteľného príslušenstva vid' časť "Technical Information".

Použitie

V tomto odstavci sú uvedené hlavné operatívne postupy. Pre ostatné detaily a pre postupy, ktoré sa vzťahujú na napojenia, alebo na zvolené príslušenstvo, postupujte podľa časti "Use" v dodatku "Technical Information".

Pred použitím "Controller" preveďte všetky potrebné elektrické a pneumatické napojenia a riad'te sa podľa návodu napojeného čerpadla.

NEBEZPEČIE!



Pred začiatkom manipulácie si z dôvodu zaistenia bezpečného použitia dôkladne preštudujte priložený manuál.

POZNÁMKA

Uzavierajúca prípojka J1 sa musí nechať napojená na jej mostík vtedy, keď nie je prevedené žiadne vonkajšie napojenie. Pred-prázdňové čerpadlo a čerpadlo TwisTorr môžu byť zapnuté súčasne.

Povely, Ukazovatele a Prípojky "Controller"

Ďalej je zobrazený čelný a zadný panel controller-a. Pre ďalšie detaily konzultuje časť "Technical Information".

Popis čelného panelu

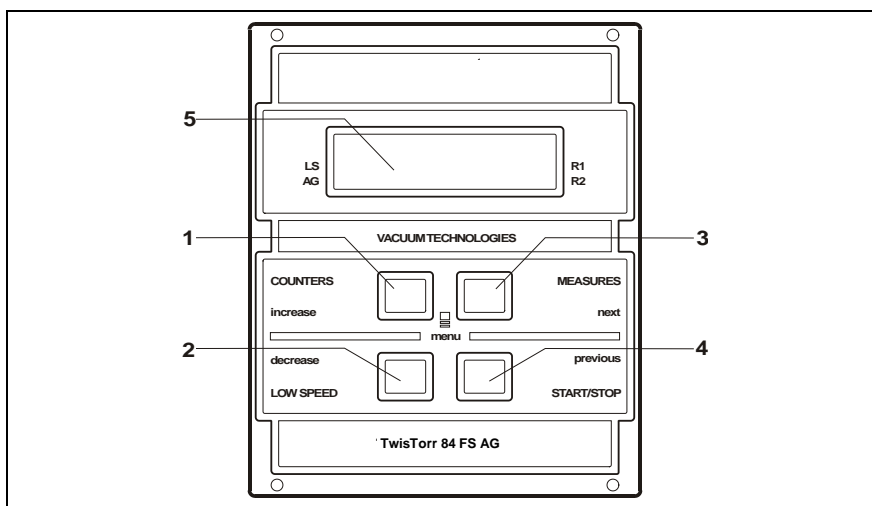

Postava 2 Čelný panel "Controller" TwisTorr 84 FS AG

1	Tlačidlo pre vyvolanie parametrov cycle number, cycle time a pump life na displej.
2	Tlačidlo pre voľbu LOW SPEED. Je aktívne iba vtedy, keď povel vychádza z čelného panelu. Keď sa stlačí raz, čerpadlo sa točí rýchlosťou „stand by“. Stlačiac ho druhý raz, sa vypne LOW SPEED.
3	Tlačidlo pre vyvolanie parametrov "pump current", "pump temperature", "pump power", "rotational speed". Je stále aktívne, nezávisle od voľby funkcie. Stlačiac spolu tlačidlá 3 a 1 na aspoň 2 sekundy, sa spustí program, s ktorým ke možné zvolíš niektoré operatívne parameter.
4	Tlačidlo povelov ŠTART, STOP/RESET. Je aktívne iba vtedy, keď povel vychádza z čelného panelu. Keď sa stlačí raz, spustí sa fáza naštartovania; stlačiac ho znovu sa zastaví čerpadlo. Keď sa čerpadlo v prípade poruchy zastaví automaticky, treba stlačiť tlačidlo prvý krát pre resetovanie "controller" a druhý krát pre znovunaštarovanie čerpadla.
5	Alfanumerický displej na tekutý kryštál: bodová matica, 2 línie x 16 písmen.

14 Návod na Obsluhu

Použitie

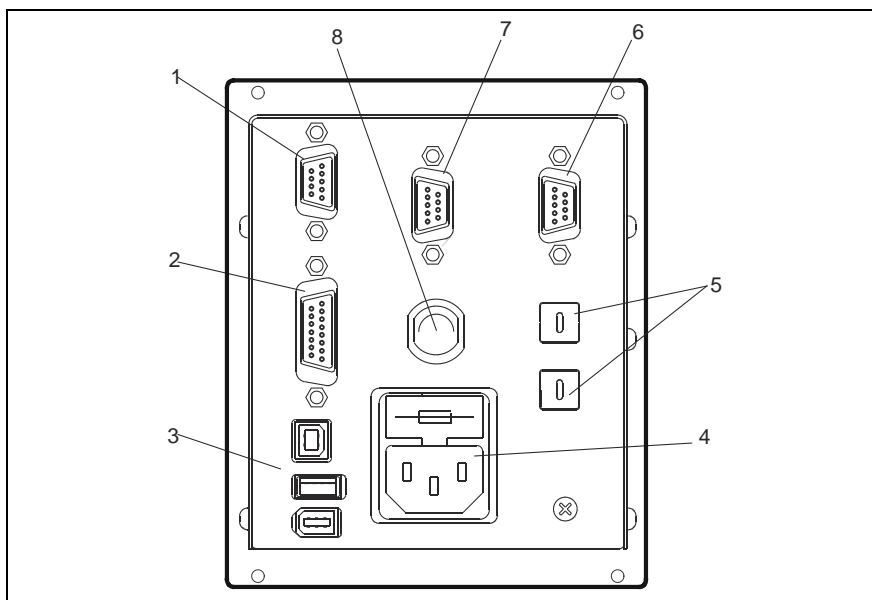

Postava 3 Zadný panel "controller TwisTorr 84 FS AG

1	Vstupná spojka logických signálov (spojovacia spojka je doganá s príslušným uzavierajúcim mostíkom).
2	Spojka východzích logických signálov a monitorovanie frekvencie čerpadla a navyše programovateľný analogický výstup.
3	Výstupá spojka napájania (24 Vdc pre chladiacu lopatku čerpadla, odvzdušňovací ventil a vákuometer).
4	Vstupný modul napájania controller-u, obsahujúci poistky, napájaciu zásuvku a filter ENC.
5	Rotačný switch pre nastavenie adresy Profibusu (na požiadavku).
6	Profibus (na požiadavku).
7	Sériová spojka pre diaľkovú kontrolu.
8	Kábel čerpadla (dĺžka 5 m).

Postup pri použití

Zapnutie "Controller"

Pre zapnutie "controller" stačí zapojiť kábel na elektrickú sieť a vypínač siete dať do polohy 1.

Naštartovanie čerpadla

Pre naštartovanie čerpadla, potvrdte vstup zámku (skrátene kolíky 3÷8 na P1) a stlačte tlačidlo START na prednom ovládacom paneli.

Zastavenie čerpadla

Pre zastavenie čerpadla treba stlačiť tlačidlo STOP na čelnom paneli.

Údržba

"Controllers" série TwisTorr 84 FS AG Rack nevyžadujú žiadnu údržbu. Akýkoľvek zásah musí previesť poverený personál.

V prípade vady je možné využiť opravnú službu Agilent alebo "Agilent advanced exchange service", ktorá vymení vadný "controller".

NEBEZPEČIE!



Pred akýmkoľvek zásahom na "controller" vyťahnite šnúru z elektrickej siete.

Ak je potrebné odstrániť kontrolór, likvidácia musí prebehnúť v súlade so špecifickými štátnymi normami.

Likvidácia

Význam loga "WEEE" nachádzajúceho sa na štítkoch. Aplikovanie doluo označeného symbolu dodržiava smernicu EÚ s názvom "WEEE". Tento symbol (**platný iba pre štáty Európskej Únie**) znamená, že výrobok s týmto štítkom NEMIE byť odstránený spolu s bežným domácim alebo priemyselným odpadom, ale sa musí odstrániť ako delený odpad. Vyzývame preto konečného užívateľa, aby sa skontaktoval s dodávateľom prístroja, či už je to výrobca alebo predajca za účelom jeho likvidácie podľa zmluvných podmienok predaja.



Viac informácií nájdete na:

<http://www.agilent.com/environment/product/index.shtml>

Oznamy vąd

Kontrolór sám diagnostikuje niektoré príčiny chýb a zobrazí nasledujúce oznámenia:

Tab. 1

OZNAM	POPIS	ZÁSAH OPRAVY
CHECK CONNECTION TO PUMP	Nefunguje napojenie medzi čerpadlom a "controller". Alebo Čerpadlo má nižšiu teplotu ako 0 °C.	Skontrolujte, či je spojovací kábel medzi čerpadlom a "controller" správne zasunutý na oboch koncoch a či nie je prerušený. Stlačte dvakrát tlačidlo START pre znovunaštartovanie čerpadla.
WAITING INTERLOCK	je aktívny signál interlock na spojke P1 z dôvodu prerušenia skratu medzi pin 3 a pin 8 spojky J1, alebo z dôvodu otvorenia signálu vonkajšieho interlock.	Zapojte pin 3 do pin 8 konektoru P1 alebo uzavrite externý signál zámku.
PUMP OVERTEMP.	Teplota horného ložiska alebo čerpadla prekročila 60 °C.	Vyčkať, až sa teplota opäť vráti pod hranicu. Stlačte dvakrát tlačidlo START pre znovunaštartovanie čerpadla.
CONTROLLER OVERTEMP.	Teplota "controller" prekročila 70 °C. Alebo Teplota radiátora controllera presahuje 60 °C.	Počkať, kým teplota neklesne pod hranicu. Stlačte dvakrát tlačidlo START pre znovunaštartovanie čerpadla

14 Návod na Obsluhu

Oznamy vúd

OZNAM	POPIS	ZÁSAH OPRAVY
TOO HIGH LOAD	Nastavený ťah čerpadla je príliš vysoký.	Skontrolujte, či má rotor čerpadla možnosť točiť sa voľne. Stlačte dvakrát tlačidlo START pre znovunaštartovanie čerpadla
SHORT CIRCUIT	Na konektore čerpadla je krátky obvod.	Skontrolujte zapojenie a krátke obvody medzi čerpadlom a "controller". Stlačte dvakrát tlačidlo START pre znovunaštartovanie čerpadla
SYSTEM OVERRIDE	Núdzový signál, vychádzajúci z diaľkového kontaktu zastavil čerpadlo.	Vytiahnite šnúru z elektrickej siete "controller" a ostráňte dôvod alarmu. Zasuňte napájaciu šnúru a stlačte dvakrát tlačidlo START pre znovunaštartovanie čerpadla.
OVERVOLTAGE	Dodávka energie pre obvody kontrolóra je chybná alebo kontrolór dostal neočakávané veľké množstvo napätia.	Stlačte dvakrát tlačidlo START pre znovunaštartovanie čerpadla. Keď sa tento oznam objaví znovu, obráťte sa na firmu Agilent pre údržbu.
POWER FAIL	Zlyhanie v časti dodávky energie.	Pre údržbu sa obráťte na Agilent.

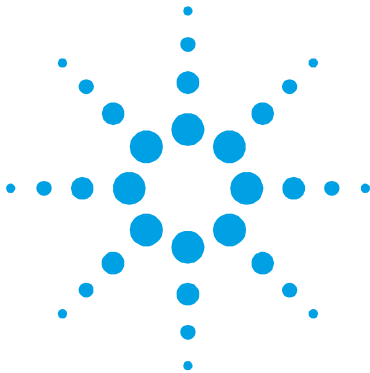

15 Priročnik za Navodila

Splošne informacije	184
Skladiščenje	185
Priprava za montažo	186
Montaža	187
Uporaba	188
Komande, indikatorji in konektorji	189
Opis prednje plošče	189
Postopki uporabe	191
Vklonitev Controllera	191
Zagon črpalke	191
Zaustavitev črpalke	191
Vzdrževanje	191
Odlaganje odpadkov	192
Obvestilo o napaki	193

Prevod navodil v izvirniku



Splošne informacije

Naprava je namenjena samo za strokovno rabo. Uporabnik mora temeljito prebrati priročnik in pri tem upoštevati vsako dodatno informacijo, ki jo nudi Agilent. Agilent ne odgovarja v slučaju celotnega ali delnega nespoštovanja navodil, pri nepravilni uporabi nestrokovnega osebja, v slučaju nedovoljenih posegov ali pri zanemarjenju specifičnih nacionalnih meril. Controllerji serije TwisTorr 84 FS AG Rack so frekvenčni pretvorniki, na katere nadzor ima mikrokrmilnik. Sestavljajo jih deli v solidnem stanju, ki imajo značilnosti avtodiagnoze in avtozaščite.

Značilnosti controllerja:

- Osrednja/oddaljena/serijska operativnost
- Upravljanje na 24 Vdc ventila ohlajevalne črpalke
- Upravljanje vent valve
- Branje hitrosti črpalke po ukazu zaustavitve (branje zaustavitvene hitrosti)
- Branje pritiska
- Vmesnik Profibus (opcijski)
- Avtomatična postavitev vhodne napetosti.

V naslednjih odstavkih so navedene vse informacije potrebne za zagotavljanje sigurnosti uporabnika med rokovanjem s to napravo. Podrobnejše informacije dobite v priponki "Technical Information".

V tem priročniku so varnostne informacije razvrščene v dva razreda:

SVARILO!



Znak svarila opozarja uporabnika, da mora pri določenem postopku ali pri posebnem delovanju paziti. Kršitev svarila lahko privede do lažjih ali hudih telesnih poškodb.

POZOR!

Znak 'pozor' se pojavi pred postopke, ki če jih uporabnik zanemari, lahko napravo poškoduje.

OPOMBA

Opombe vsebujejo vse najbolj pomembne informacije iz besedila.

Skladiščenje

Med prevozom in skladiščenjem controllerjev morate zagotoviti naslednje pogoje okolice:

- temperatura: od -20 °C do +70 °C
- relativna vlaga: 0 – 95 % (bez kondenzacije).

Priprava za montažo

Controller dobite v posebni zaščitni embalaži; če so na embalaži znaki poškodbe, ki naj bi nastale med transportom obrnite se krejavnemu prodajalnemu biroju.

Pri odstranitvi embalaže morate še posebno paziti, da controller ne pade na tla ali da ne podleigne udarcem. Ne zavržite embalaže v okolico. Material lahko v celoti reciklirate in ustreza direktivi CEE 85/399 za zaščito okolja.

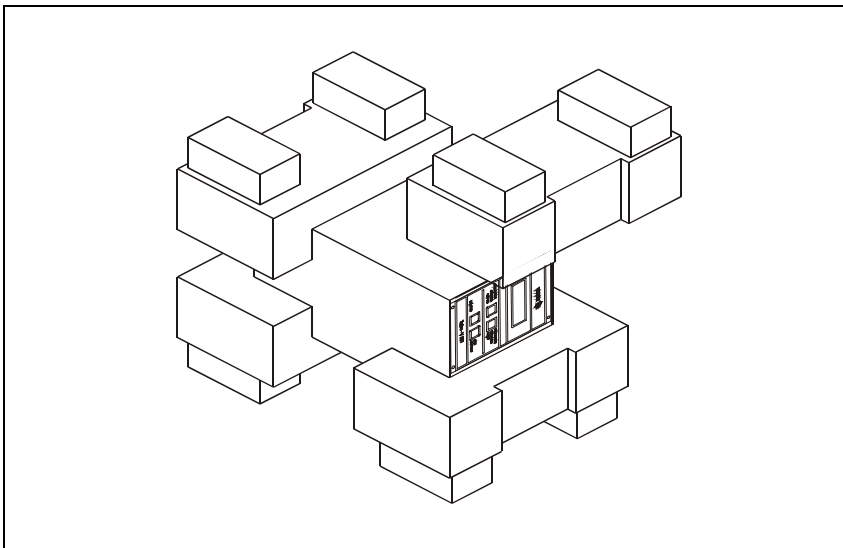

Slika 1 Embalaža controllera

Montaža

SVARILO!



Controller ima napajalni vod s tremi žicami (gledaj tudi preglednico delov, ki lahko naročiš) in mednarodno priznan vtikač za varnost uporabnika. Uporabljajte vedno ta napajalni kabel in vtaknite vtikač v vtičnico z ustreznim masovnim vezanjem, ker drugače vas lahko strese električni tok in da se tako pridržite ES meril. Znotraj controller-jev se stvori visoka napetost, ki lahko človeku povzroči hude poškodbe ali celo smrt. Preden bi nadaljevali s katerokoli dejavnostjo montaže ali pa vzdrževanja, izklopite controller iz vtičnice.

OPOMBA

Controller lahko montirate na mizo ali vgradite v notranjost ustreznega rack-a. V vsakem slučaju morate poskrbeti, da voda za hlajenje prosto kroži skozi napravo. Controller-a ne smete montirati ali uporabiti v okolici, ki je izpostavljena klimatskim dejavnikom (dežju, ledu, snegu), prahu, agresivnim plinom, v okolici kjer obsatja nevarnost vnetja ali požara.

Med delovanjem morate zagotoviti naslednje pogoje okolice:

- temperatura: od +5 °C do +45 °C;
- relativna vlaga: 0 – 95 % (ne-kondezna).

Kar se tiče priključkov in montaže opcionalnih dodatkov, si lahko ogledate priponko "Technical Information".

Uporaba

V tem odsatvku so navedeni vsi glavni operativni postopki. Za dodatne detalje in postopke, ki zadevajo priključitve ali posamezne opcije, si lahko ogledate odstavek "Use" v priponki "Technical Information".

Predno bi uporabili controller, morate priključiti vse električne in pnevmatske kable, pri tem se nanajšate na priročnik priložene črpalke.

SVARILO!



Pred zagonom si poglejte ustrezen priročnik za varno upravljanje in delovanje črpalke.

OPOMBA

Zapiralni konektor J1 mora ostati priključen k svojemu mostičku, če niste izvršili nikakršne druge zunanje priključitve. Črpalko predhodnega praznjenja in črpalko TwisTorr lahko istočasno vklopite.

Komande, indikatorji in konektorji

Sledi prikaz prednje in ozadnje plošče controllera. Za podrobnejše informacije si ogledajte paragraf "Technical Information".

Opis prednje plošče

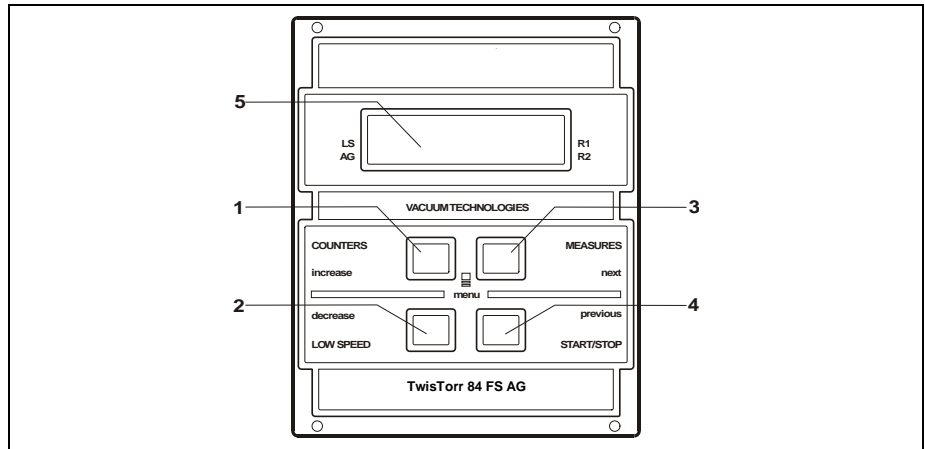

Slika 2 Prednja plošča Controllera TwisTorr 84 FS AG

1	Tipka za preklic na zaslonu parametrov cycle number, cycle time in pump life.
2	Tipka za LOW SPEED modus je aktivna samo nato, ko ste izbrali to komando iz prednje plošče. Če gumb enkrat pritisnete, črpalka vrti na hitrosti "stand-by". Če še enkrat pritisnete gumb, izključite LOW SPEED modus.
3	Tipka za preklic na zaslonu parametrov "pump current", "pump power", "rotational speed", temperatura spodnjega ležišča temperatura gornjega ležišča, temperatura motora, frekvenca vzburljenja. Ta tipka je vedno aktivna neodvisno od modusa delovanja, ki ste ga izbrali. Če skupaj pritisnete gumb 3 in 1 za vsaj dve sekundi aktivirate program, s katerim je mogoče nastaviti nekatere operativne parametre.
4	Tipka za zagon komand START, STOP/RESET. Aktivna je samo nato, ko ste to komando izbrali iz prednje plošče. Če gumb enkrat pritisnete boste pognali črpalko; če ga še enkrat pritisnete, boste črpalko zaustavili. Če se je črpalka sama zaustavila zaradi kvara, morate to tipko enkrat pritisniti, da bi lahko controller-a resetirali in še drugič za ponoven zagon črpalke.
5	Alfaštevilčni zaslon iz tekočih kristalov: prebija bodov, 2 linije x 16 znaka.

15 Priročnik za Navodila

Uporaba

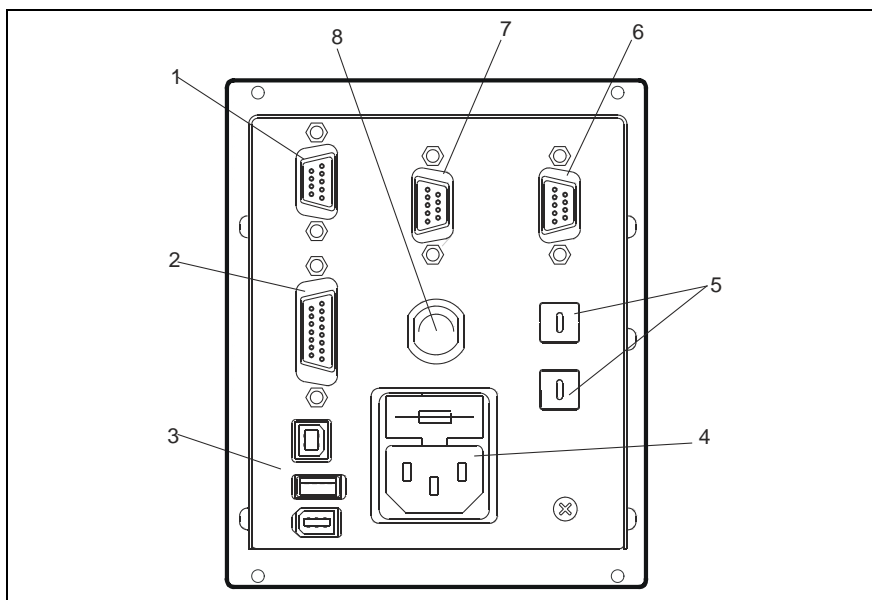

Slika 3 Ozadnja plošča Controllera TwisTorr 84 FS AG

1	Vhodni konektor logičnih signalov (spajalni konektor ima ustrezen zapiralni mostiček)
2	Konektor logičnih izhodnih signalov in nadzor frekvence črpalke plus analogični izhod, ki lahko programirate.
3	Izhodni napajalni konektor (24 V za hladilni ventilator črpalke, odzračevalni ventil in merilnik).
4	Vhodni modul napajanje controller-a, ki vsebuje varovalke, napajalno stikalo in filter ENC.
5	Rotacijski Switch za nastavljanje Profibusnega naslova (kot opcija).
6	Profibus (kot opcija).
7	Serijski konektor za nadzor iz oddaljenosti
8	Kabel črpalke (dolžina 5 m).

Postopki uporabe

Vklopitev Controllera

Za vklopitev Controller-a morate napajalni kabel vtakniti v omrežno vtičnico.

Zagon črpalke

Za vklop črpalke potrdite vnos blokade (skrajšajte žebličke 3÷8 na P1) in pritisnite gumb START na sprednji kontrolni plošči.

Zaustavitev črpalke

Zaustavite črpalke s tipko STOP na prednji plošči.

Vzdrževanje

Controllerji serije TwisTorr 84 FS AG Rack ne potrebujejo vzdrževanja. Samo pooblaščen osebje lahko rokuje s to napravo.

V slučaju okvare obrnite se servisu Agilent ali "Agilent advanced exchange service", ki Vam bo dal na razpolago obnovljeni controller.

SVARILO!

Pred katerikoli posegom, izklopite iz controller-a. napajalni kabel



Če je treba krmilnik zavreči, ga je treba zavreči v skladu s specifičnimi nacionalnimi standardi.

Odlaganje odpadkov

Pomen znamke "WEEE" na etiketah. Spodaj navedeni simbol je v skladu z direktivo ES znano pod imenom "WEEE". Ta simbol **(ki velja samo v državah Evropske Skupnosti)** pomeni, da izdelek NE SMETE ODSTRANITI skupaj z ostalimi komunalnimi ali pa industrijskimi odpadki, temveč morate poskrbeti za njihovo primerno ločevanje. Zato pozivamo uporabnike, da se ali pri prodajalnem centru ali pa pri prodajalcu seznanijo o postopku ločevanja in odstranitve odpadkov, šele nato, ko se je seznanil s pogoji in z merili kupopordajne pogodbe.



Za dodatne informacije se obrnite na:

<http://www.agilent.com/environment/product/index.shtml>

Obvestilo o napaki

Krmilnik bo samo-diagnosticiral nekatere napake in pri tem prikazal naslednja sporočila:

Tab. 1

OBVESTILO	OPIS	POPRAVA
CHECK CONNECTION TO PUMP	Napaka v priključitvi črpalke in controller-a. Ali Črpalka ima nižjo temperaturo od 0 °C.	Preverite, da je priključni kabel med črpalko in controller-em na obeh koncih trdno pritrjen in da ni prekinjen. Dvakrat pritisnite tipko START za ponoven zagon črpalke.
WAITING INTERLOCK	Signal interlocka prisoten na konektorju P1 zaradi prekinitve kratkega stika med pinom 3 in pinom 8 konektorja J1, ali ker se je odprl signal zunanjega interlocka.	Povežite žebličke 3 do 8 konektorja P1 ali zaprite zunanji signal blokade.
PUMP OVERTEMP.	Temperatura gornjega ležišča ali črpalke je presegla i 60 °C.	Počakajte, da se temperatura vrne pod normalnim vrednostnim pragom. Pritisnite dvakrat tipko START za ponoven zagon črpalke.
CONTROLLER OVERTEMP.	Temperatura controllera je presegla 70 °C. Ali Temperatura controllerskega radiatorja je višja od 60 °C.	Počakajte, da se temperatura vrne pod normalnim vrednostnim pragom. Dvakrat pritisnite tipko START za ponoven zagon črpalke.

15 Priročnik za Navodila

Obvestilo o napaki

OBVESTILO	OPIS	POPRAVA
TOO HIGH LOAD	Jakost toka, ki ga porabi črpalka, je previsoka.	Preverite, da lahko rotor črpalke prosto vrti. Dvakrat pritisnite tipko START za ponoven zagon črpalke.
SHORT CIRCUIT	Na konektorju črpalke je prisoten kratek stik.	Preverite priključke in kratke stike med črpalko in krmilnikom. Dvakrat pritisnite tipko START za ponoven zagon črpalke.
SYSTEM OVERRIDE	Delovanje črpalke je zaustavil signal zasilnosti iz oddaljenega kontakta.	Izklopite napajalni kabel controllera in popravite napako, ki se je pojavila s signalom zasile. Ponovno priključite napajalni kabel in pritisnite dvakrat tipko START za ponoven zagon črpalke.
OVERVOLTAGE	Napajanje krmilnika je okvarjeno ali pa je krmilnik prejel nepričakovano preveliko napetost.	Dvakrat pritisnite tipko START za ponoven zagon črpalke. Če se to obvestilo spet pojavi, obrnite se Agilent za pravilno vzdrževanje.
POWER FAIL	Okvara na napajanju.	Obrnite se Agilent za pravilno vzdrževanje.

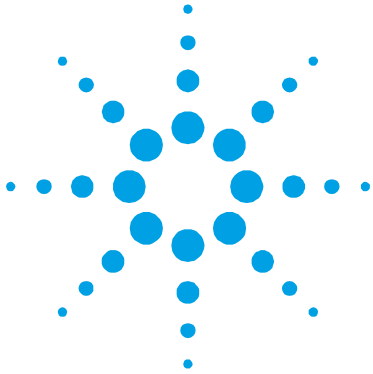

16 Instructions for Use

General Information	196
Storage	197
Preparation for Installation	198
Installation	199
Use	200
Controls, Indicators and Connectors	201
Front Panel Description	201
Use Procedure	203
Controller Startup	203
Starting the Pump	203
Pump Shutdown	203
Maintenance	203
Disposal	204
Error Messages	204

Original Instructions



General Information

This equipment is destined for use by professionals. The user should read this instruction manual and any other additional information supplied by Agilent before operating the equipment. Agilent will not be held responsible for any events occurring due to non-compliance, even partial, with these instructions, improper use by untrained persons, non-authorized interference with the equipment or any action contrary to that provided for by specific national standards.

The TwisTorr 84 FS AG Rack controllers are micro-processor-controlled, solid-state, frequency converter with self-diagnostic and self-protection features.

Controller features:

- Front / Remote / Serial Operation
- 24Vdc pump fan cooling drive
- Vent valve drive
- Pump speed reading after stop command (stop speed reading)
- Pressure reading
- Input voltage auto setting.
- Profibus interface (optional)

The following paragraphs contain all the information necessary to guarantee the safety of the operator when using the equipment. Detailed information is supplied in the appendix "Technical Information".

This manual uses the following standard protocol:

WARNING!



The warning messages are for attracting the attention of the operator to a particular procedure or practice which, if not followed correctly, could lead to serious injury.

CAUTION!

The caution messages are displayed before procedures which, if not followed, could cause damage to the equipment.

NOTE

The notes contain important information taken from the text.

Storage

When transporting and storing the controllers, the following environmental requirements should be satisfied:

- temperature: from -20 °C to + 70 °C
- relative humidity: 0 – 95 % (without condensation)

Preparation for Installation

The controller is supplied in a special protective packing. If this shows signs of damage which may have occurred during transport, contact your local sales office. When unpacking the controller ensure that it is not dropped or subjected to any form of impact. Do not dispose of the packing materials in an unauthorized manner. The material is 100 % recyclable and complies with EEC Directive 85/399.

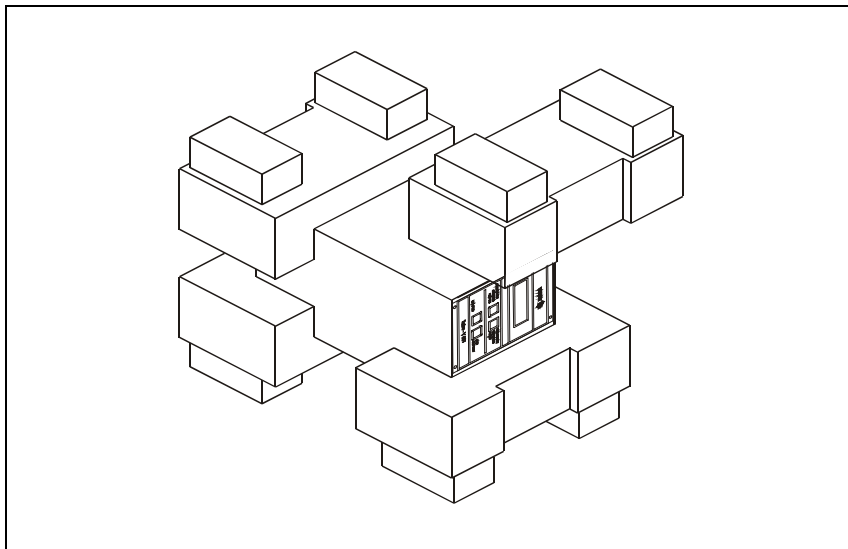

Figure 1 Controller Packaging

Installation

WARNING!



The TwisTorr controller is designed for indoor use only and must be powered with 3-wire power cord (see orderable parts table) and plug (internationally approved) for user safety. Use this power cord and plug in conjunction with a properly grounded power socket to avoid electrical shock and to satisfy CE requirements. High voltage developed in the controller can cause severe injury or death. Before servicing the unit, disconnect the input power cable.

NOTE

The TwisTorr controller can be used as a bench unit or a rack module, but it must be positioned so that free air can flow through the holes. Do not install or use the controller in an environment exposed to atmospheric agents (rain, snow, ice), dust, aggressive gases, or in explosive environments or those with a high fire risk.

During operation, the following environmental conditions must be respected:

- temperature: from +5 °C to +45 °C;
- relative humidity: 0 – 95 % (without condensation).

See the appendix “Technical Information” for detailed Information about the above mentioned and the other connections, and about the options installation.

Use

This paragraph describes the fundamental operating procedures. Detailed information and operating procedures that involve optional connection or option are supplied in the paragraph “USE” of the appendix “Technical Information”.

Make all vacuum manifold and electrical connections and refer to TwisTorr pump instruction manual before operating the TwisTorr controller.

WARNING!

Refer to the relevant pump manual to operate it in a safe way before starting.



NOTE

The input signal J1 connector should be left in position including the shipping links if no external connections are made. The forepump and TwisTorr pump can be switched on at the same time.

Controls, Indicators and Connectors

The following paragraph illustrates the Controller control panel and interconnection panel. More details are contained in the appendix “Technical Information”.

Front Panel Description

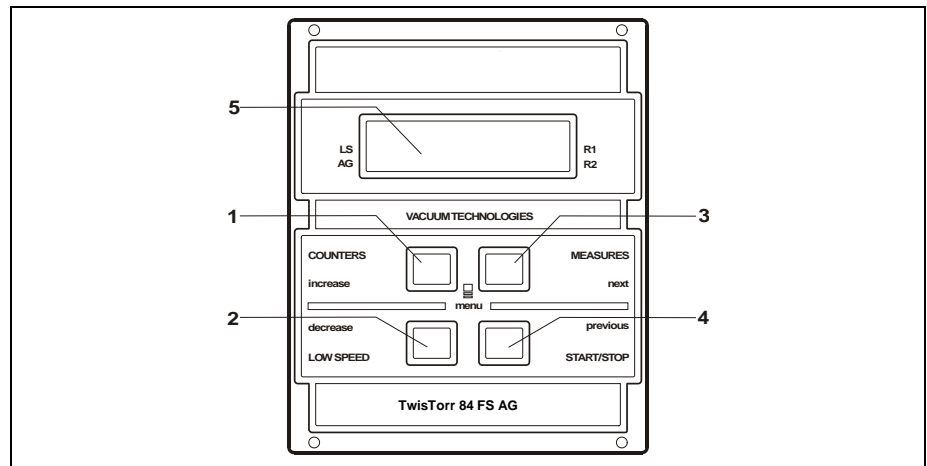

Figure 2 Controller TwisTorr 84 FS AG Front Panel

1	Keyboard push-button to recall on the display the cycle number, cycle time and pump life.
2	Keyboard push-button for LOW SPEED mode selection. It is active only when the front panel operation has been selected. Pressed once, the pump runs at “stand-by” speed. To unselect the mode, press the push-button again.
3	Keyboard push-button to recall on the display the “pump current”, “pump temperature”, “pump power” and “rotational speed”. It is always active regardless of the operating mode selected. Push-buttons 3 and 1, if pressed together for at least 2 seconds, put the controller in a routine where it is possible to program some operation parameters.
4	Keyboard push-button for START, STOP/RESET mode selection. It is active only when the front panel operation has been selected. By pressing once the starting phase begins; if pressed again it stops the pump. If the pump has been stopped automatically by a fault, this push-button must be pressed once to reset the controller and a second time to restart the pump.
5	LCD back-lighted alphanumeric display: dot matrix 2 lines x 16 characters.

16 Instructions for Use

Use

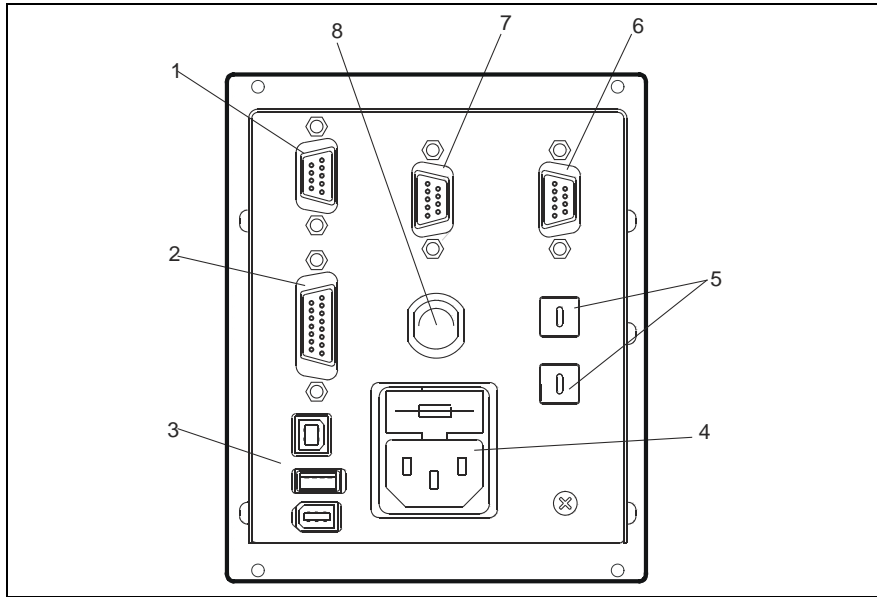

Figure 3 Controller TwisTorr 84 FS AG Rear panel

1	Logic input signals connectors (mating connector supplied with link).
2	Logic output signals connector and pump frequency monitor plus programmable analog output.
3	Power output connector (24 Vdc for pump cooling fan, Vent Valve and Gauge).
4	Controller power entry module consisting of mains fuses, mains socket and EMC filter.
5	Rotary switches for Profibus address setting (Optional).
6	Profibus (Optional).
7	Remote control serial connector.
8	Pump cable (5m long).

Use Procedure

Controller Startup

To startup the controller plug the power cable into a suitable power source.

Starting the Pump

To start the pump, confirm the interlock input (shorting pins 3÷8 on P1) and press the START pushbutton on the controller front panel.

Pump Shutdown

To shutdown the pump press the STOP push-button on the controller front panel.

Maintenance

The TwisTorr 84 FS AG Rack series controller does not require any maintenance. Any work performed on the controller must be carried out by authorized personnel.

When a fault has occurred it is possible to use the Agilent repair service. Replacement controllers are available on an advance exchange basis through Agilent.

WARNING!

Before carrying out any work on the controller, disconnect it from the supply.



If a controller needs to be scrapped, it must be disposed off in accordance with the specific national standards.

Disposal

Meaning of the "WEEE" logo found in labels

The following symbol is applied in accordance with the EC WEEE (Waste Electrical and Electronic Equipment) Directive. This symbol (**valid only in countries of the European Community**) indicates that the product it applies to must NOT be disposed of together with ordinary domestic or industrial waste but must be sent to a differentiated waste collection system. The end user is therefore invited to contact the supplier of the device, whether the Parent Company or a retailer, to initiate the collection and disposal process after checking the contractual terms and conditions of sale.



For more information refer to:

<http://www.agilent.com/environment/product/index.shtml>

Error Messages

The controller will self-diagnose some error causes and will display the following messages:

Tab. 1

MESSAGE	DESCRIPTION	REPAIR ACTION
CHECK CONNECTION TO PUMP	Wrong connection between the pump and the controller. OR The pump temperature is below 0°C.	Check connection between controller and pump. Press the START push-button twice to start the pump.
WAITING INTERLOCK	The interlock signal of P1 connector is activated by an interruption of the link between pin 3 and 8 of J1 connector, or because the external interlock signal is open.	Connect pin 3 to pin 8 of P1 connector, or close the external interlock signal.
PUMP OVERTEMP.	The upper bearing/pump temperature exceeds 60°C.	Wait until the temperature decreases below threshold value. Press the START push-button twice to start the pump.
CONTROLLER OVERTEMP.	The controller environment temperature exceeds 70°C. OR The controller radiator temperature is above 60°C.	Wait until the temperature decreases below threshold value. Press the START push-button twice to start the pump.

16 Instructions for Use

Error Messages

MESSAGE	DESCRIPTION	REPAIR ACTION
TOO HIGH LOAD	The current drawn by the pump is too high.	Check that the pump rotor is free to rotate. Press the START push-button twice to start the pump.
SHORT CIRCUIT	A short circuit is present on the pump connector.	Check connections and short circuits between pump and controller. Press the START push-button twice to start the pump.
SYSTEM OVERRIDE	The pump is stopped by an emergency stop signal provided via a remote contact.	Remove the controller power cable and check the emergency condition. Then reconnect the power cable and press the START push-button twice to start the pump.
OVERVOLTAGE	Controller power supply circuitry is faulty or the Controller received an unexpected excessive voltage.	Press the START push-button twice to start the pump. Should the message still be present, call the Agilent service.
POWER FAIL	Failure in the power supply section.	Contact Agilent for Maintenance.

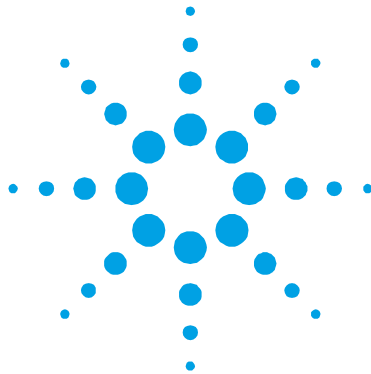

17 Technical Information

TwisTorr 84 FS AG Rack Controller Description	209
Controller Specifications	211
Controller Outline	212
Controller Connection	213
J6 – Fan	213
J7 – Vent	214
P1 – Input	215
J1 – Output	216
R1 – R2 Output Diagrams	220
Programmable Analog Output Diagrams	223
Pump Connector	224
J5 – Gauge Connector	224
Stop Speed Reading and Active Stop	227
J2 – Serial Connector	228
Connector Examples	229
Serial Communication Descriptions	230
Letter Protocol Description	231
Window Protocol	237
Description	237
Communication Protocol	237
Examples	240
Window Meanings	243
How to Use by Front Panel	248
Use	253
General	253
Startup	254



17 Technical Information

Error Messages

Programming	260
Configuration Menu	260
Mode Menu	262
Pump Setting Menu	263
Input/Output Menu	265
Setpoint R1 and Setpoint R2 Submenus	268
Gauge Menu	270
Serial Menu	272
How to Use by Remote I/O	273
How to Use in Serial Mode	273
Profibus Option	275
General	275
Installation	275
Configuration	276
Software Operation and State Machine	276
Message Mapping	278
Parameter Buffer	279
Output Buffer	282
Input Buffer	283
Diagnostic Management	286
Diagnostic Buffer	288
Error Messages	290
Orderable Parts	294

TwisTorr 84 FS AG Rack Controller Description

Two controller models are available (see orderable parts table):

- with RS 232-485 (X3508-64001)
- with RS & Profibus (X3508-64002)

The controller is a solid-state frequency converter with the following features:

- Drives the pumps of the 84 FS AG family.
- Powers the pump cooling fan
- Drives the vent valve.
- Provides and acquires the pressure of the wide range gauge.
- Remote I/Os compatible with the previous version.
- Speed reading after stop command.

See the following diagram for the connections and orderable parts.

17 Technical Information
TwisTorr 84 FS AG Rack Controller
Description

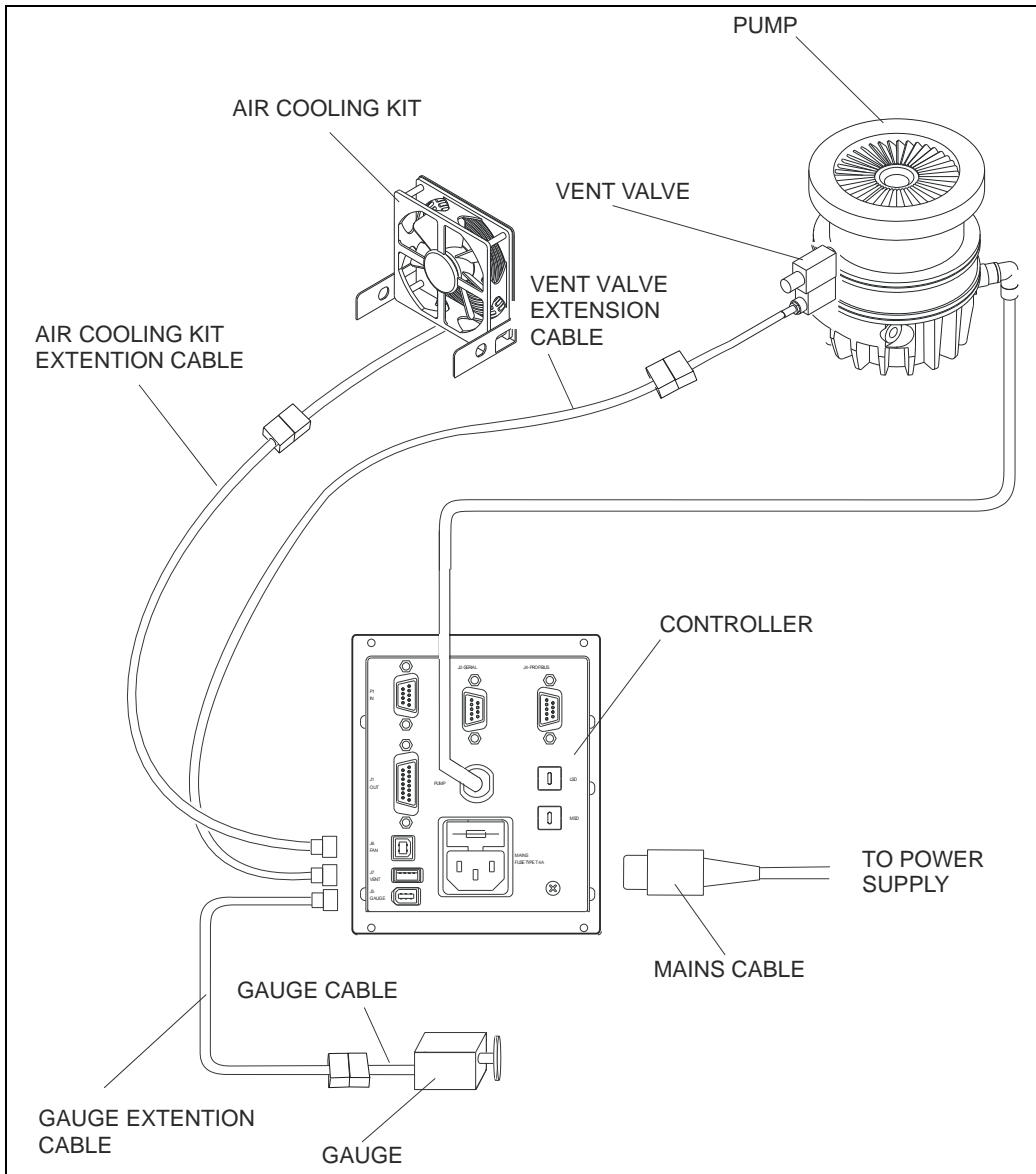

Figure 4 TwisTorr 84 FS AG Rack Controller – Connections

Controller Specifications

Tab. 2

Input:	
Voltage	100 to 240 Vac (voltage fluctuation +/- 10%)
Frequency	50 to 60 Hz
Power	450 VA
Fuse	2 x T4 A (slow blow) 250 V
Output:	
Voltage	75 Vac
Frequency	1350 Hz
Power	100 W (Ramp), 70 W (Normal and Autotuning)
Environment storage	-20 °C to +70 °C 0 – 95 %
Operating	+5 to +45 °C 0 – 90 %
Applied norr.	EN 61010 -1 EN 55011 (Class-A) EN 61000-3-2, EN 61000-3-3, EN 61000-6-2, EN 61000-4-2,3,4,5,6,11, 8
Weight:	1.7 Kg (3.2 lbs)
Pollution Degree	2
Installation Category	II
Acoustic noise (ISO7779)	LpA < 70 dB(A), normal operation, operator position

NOTE

The controller supplied voltage must be easily disconnected (through a circuit bracker or having access to the power supply cable plug).

Controller Outline

The outline dimensions for the TwisTorr 84 FS AG Rack Controllers are shown in the following figure.

NOTE

The TwisTorr controller can be used as a bench unit or as a rack module, in any case it must be positioned so that free air can flow through the housing holes.

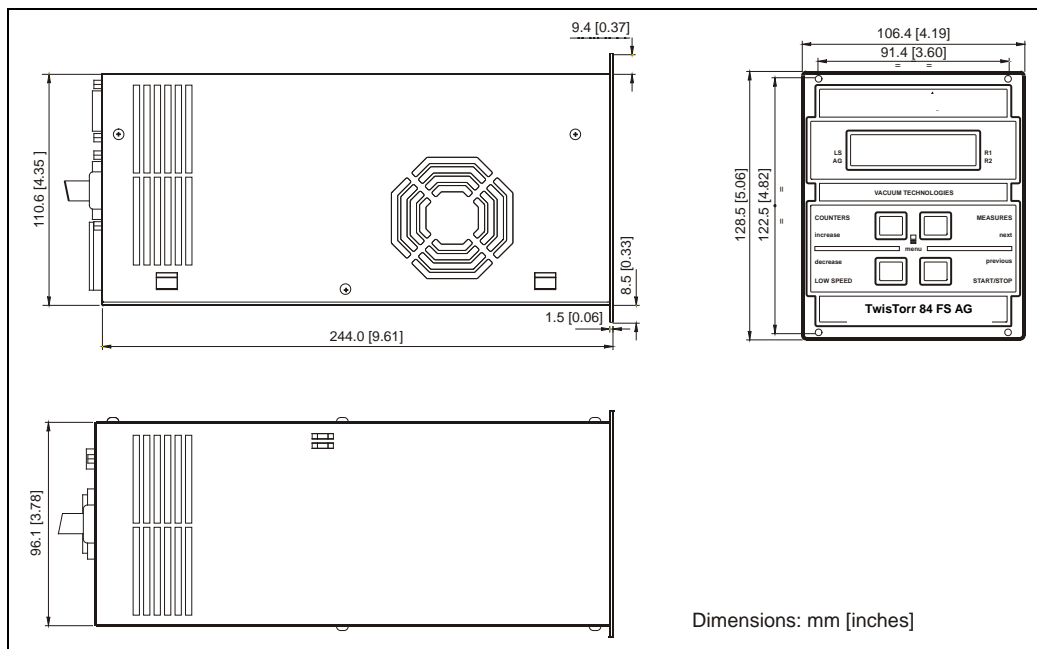

Figure 5 Controller outline

Controller Connection

J6 – Fan

The 24 Vdc, 150 mA maximum output current will be supplied according to the selected working mode (see win 143 on the serial protocol description paragraph). The default working mode is external fan active except in case of override error status.

This connection has to be used with TwisTorr 84 FS pump cooling fan (see orderable parts table).

Adapter cables are available to connect other fans.

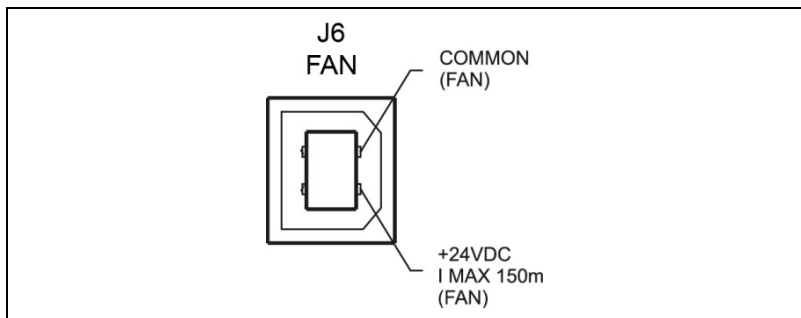

Figure 6 Fan Connector

J7 – Vent

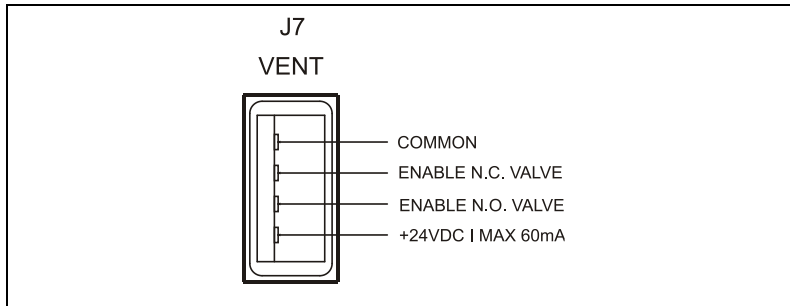

Figure 7 Vent Connector

This is the connection to control the optional vent valve (see orderable parts table). The vent valve can be driven by controller automatically or by serial line.

If you have other vent valves installed (110 Vac powered), it must be replaced (see orderable parts table).

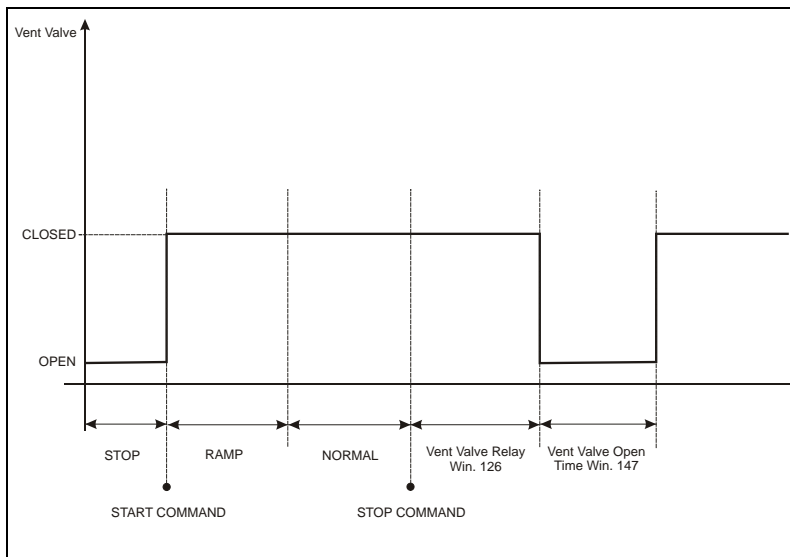

Figure 8 Vent Valve diagram in "Auto" mode

P1 – Input

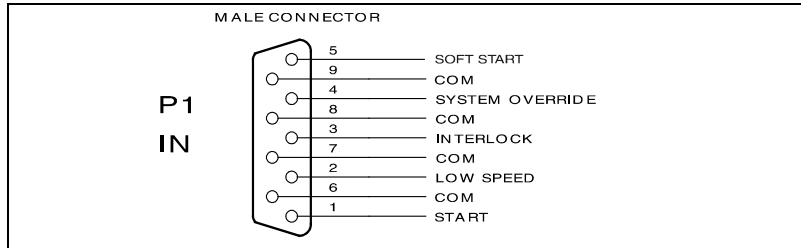

Figure 9 P1 input connector

All the logic input to the controller have to be connected to P1 mating connector. The provided P1 mating connector is equipped with pin 3 and pin 8 shorted to enable the pump start. The connections should be done with AWG 24, (0.24 mm²) or smaller wire.

The following table describes the signals available on the connector.

Tab. 3

Pins	Name	Description	Electrical	Note
1-com	Start/Stop	Contact closed = Start Contact open = Stop	Optically isolated Vlow, max = 10v Imax = 5mA Imin (on) = 2mA	Active only in Remote Mode operation
2-com	Low Speed	Contact closed = Low Speed Contact open = High Speed	Optically isolated Vlow, max = 10v Imax = 5mA Imin (on) = 2mA	Active only in Remote Mode operation
3-com	Interlock	Contact closed = Active Contact open = Inactive If active allows the pump running, if inactive stops the pump.	Optically isolated Vlow, max = 10v Imax = 5mA Imin (on) = 2mA	Active in all modes
4-com	System Override	Contact closed Contact open If the contact is open, it allows the pump running; if the contact is closed, it stops the pump and all the others connected devices (Fan, Vent).	Optically isolated Vlow, max = 10v Imax = 5mA Imin (on) = 2mA	Active in all modes

17 Technical Information

Controller Connection

Pins	Name	Description	Electrical	Note
5-com	Soft Start	Contact closed= Active Contact open= Inactive If active before the start command activates the soft start procedure. To be used only at first pump run-up.	Optically isolated Vlow, max = 10v Imax = 5mA Imin (on) = 2mA	Active only in Remote Mode operation, and in STOP status.

The following figure shows a typical contact logic input connection and the related simplified circuit of the controller.

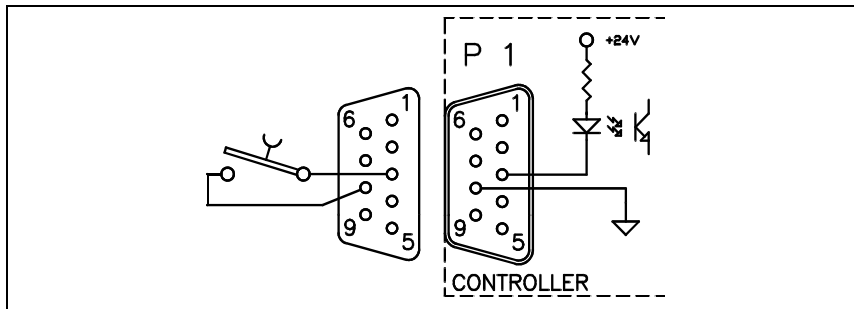

Figure 10 Typical logic input connection

J1 – Output

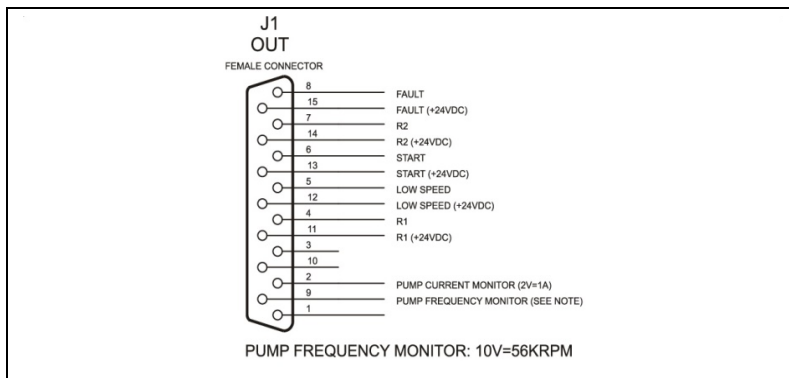

Figure 11 Logic output connector

All the logic output from the controller must be connected at J1 mating connector. The table 4 describes the signals available on the connector.

The following figure shows a typical logic output connection of a relay coil (other devices may be connected in the same way, e.g. a LED, a computer, etc.) and the related simplified circuit of the controller.

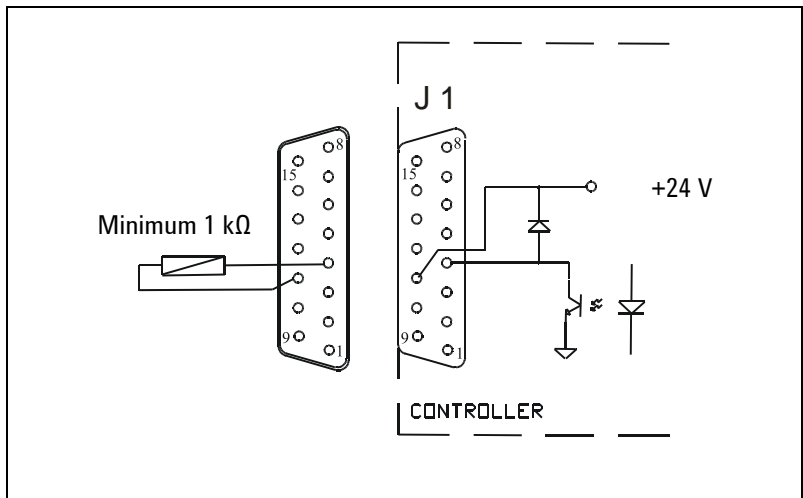

Figure 12 Digital Output Connection Example

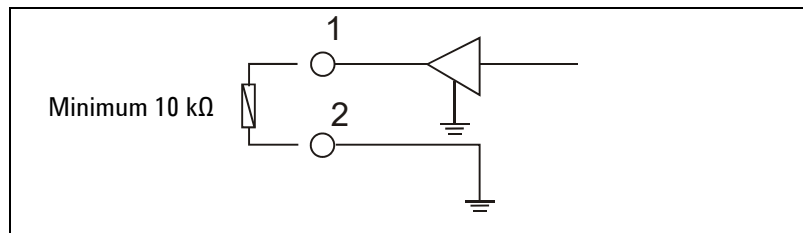

Figure 13 Analog Output Connection Example

17 Technical Information

Controller Connection

Tab. 4

Pins	Name	Description	Electrical	Note
15-8	Fault	0V = no fail 24V = fail	Optically isolated Vmax (=open) = 24V Vlow, max = 1,5V Imax = 60mA Pin-8 negative Pin-15 positive	See note 1. Connect a 10kohm resistor between the 2 pins before measuring voltage A STOP command (by front Panel or serial or Start/stop input) reset the FAIL status.
13-6	Start	Configurable output. Default setting: 24V pump in RAMP state, 0V = other state. See win 177 for further description.	Optically isolated Vmax (=open) = 24V Vlow, max = 1,5V Imax = 60mA Pin-6 negative Pin-13 positive	See note 1.
12-5	Low Speed	24V = low speed active 0V = low speed not active	Optically isolated Vmax (=open) = 24V Vlow, max = 1,5V Imax = 60mA Pin-5 negative Pin-12 positive	See note 1.
11-4	R1	Programmable Set Point Out. See note 2.	Optically isolated Vmax (=open) = 24V Vlow, max = 1,5V Imax = 60mA Pin-5 negative Pin-12 positive	See note 1.
14-7	R2	Programmable Set Point Out. See note 2.	Optically isolated Vmax (=open) = 24V Vlow, max = 1,5V Imax = 60mA Pin-7 negative Pin-14 positive	See note 1.

Pins	Name	Description	Electrical	Note
2-1	Programmable Analog Output	Programmable analog output. Can be related to: frequency, power, pump temperature (linear) or pressure read by the external gauge. The setting can be done by: front panel or serial line (win.111). 0V = 0Hz, 0W, 0°C 10V = 1350Hz, 70W, 100°C See following chart for more details	Optically isolated Rload, min = 10kohm Ripple Vpp,max = 200mV Precision = 5% Resolution = 40mV Pin-1 negative Pin-2 positive	
9-1	Frequency Analog Output	Analog output proportional to frequency (linear). 0V = 0Hz 10V = 1350Hz	Optically isolated Rload, min = 10 kohm Ripple Vpp,max = 200mV Precision = 1% Resolution = 40mV Pin-1 negative Pin-9 positive	

When the analog output is set to provide pressure signal, the voltage level is proportional to pressure level and it is generated by control unit elaborating the independent input by the active gauge.

17 Technical Information

Controller Connection

NOTE 1

A load should be present to measure the voltage on open collector output; if not present connect 10 kohm resistor between the related pins.

NOTE 2

The R1 and R2 output behaviours can be configured through the serial communication as described in the serial communication window meaning table. The related windows are:

Tab. 5

	R1	R2
Set Point type (0÷4)	Win 101	Win 171
Set Point threshold value (expressed in Hz, W or s)	Win 102	Win 172
Set Point delay: time between the pump start and the set point check (seconds)	Win 103	Win 173
Set Point signal activation type: the signal can be "high level active" or "low level active"	Win 104	Win 174
Set point hysteresis (in % of value)	Win 105	Win 175
Set Point Pressure Threshold Valid if min. 101 = 4 Format X.X EsXX Where X = 0 to 9 s = + or -	Win 162	Win 176

R1 – R2 Output Diagrams

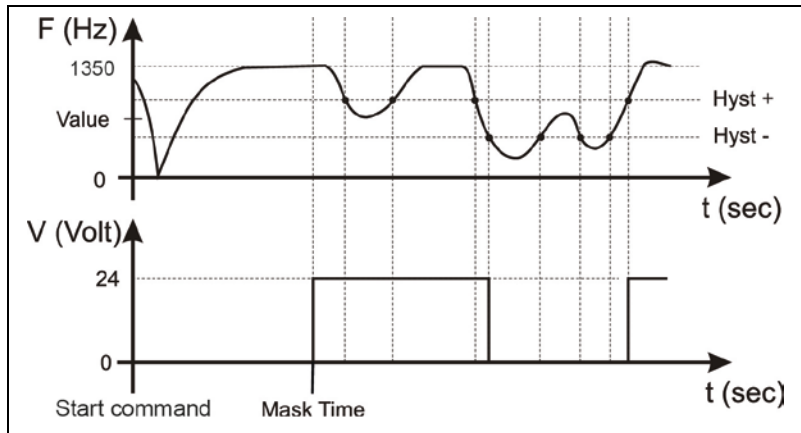

Figure 14 Diagram 1 – R1 or R2 related to frequency

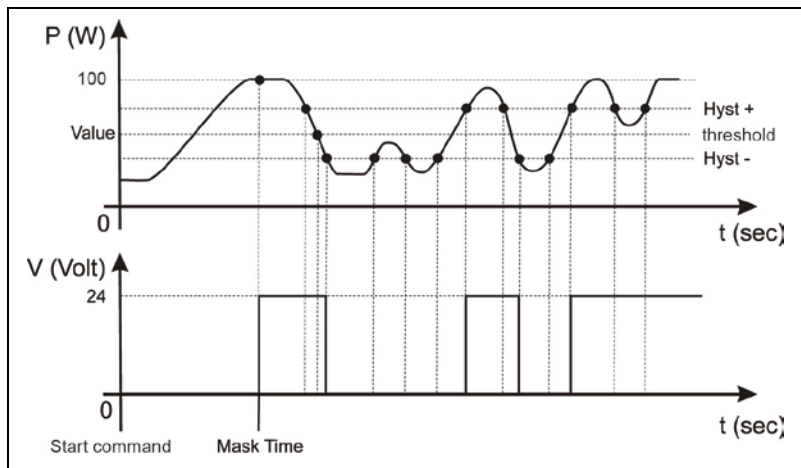

Figure 15 Diagram 2 – R1 or R2 related to power

17 Technical Information
R1 – R2 Output Diagrams

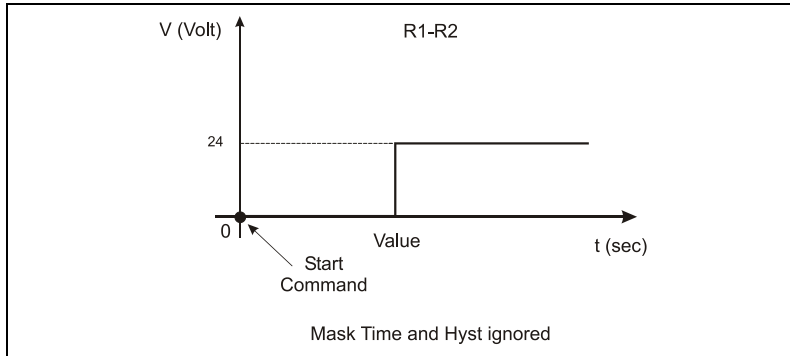

Figure 16 Diagram 3 – R1 or R2 related to time

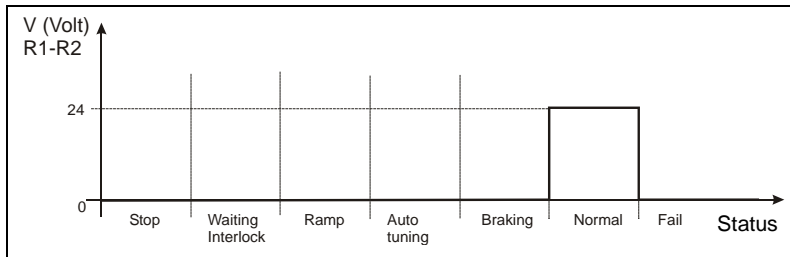

Figure 17 Diagram 4 – R1 or R2 related to Normal status

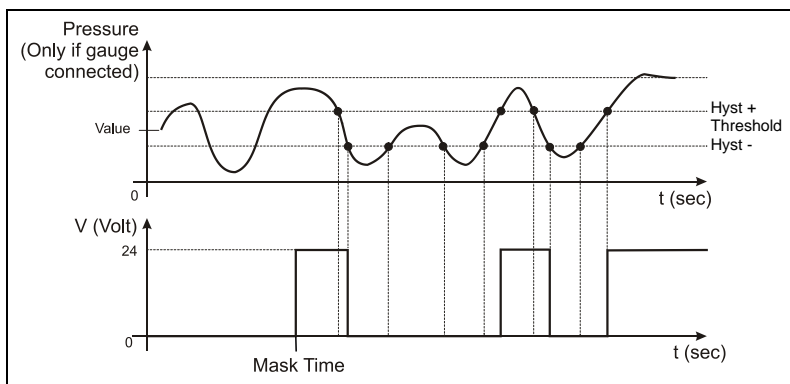

Figure 18 Diagram 5 – R1 or R2 related to pressure reading (if gauge connected)

Programmable Analog Output Diagrams

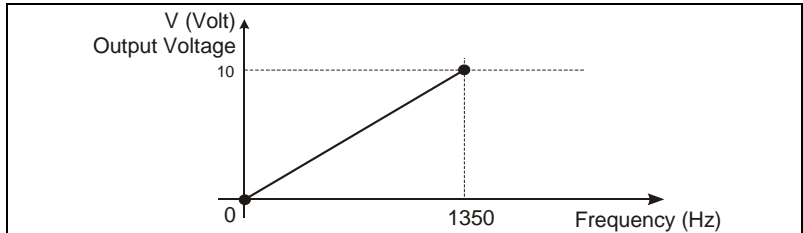

Figure 19 Diagram 1 – Programmable analog output related to frequency

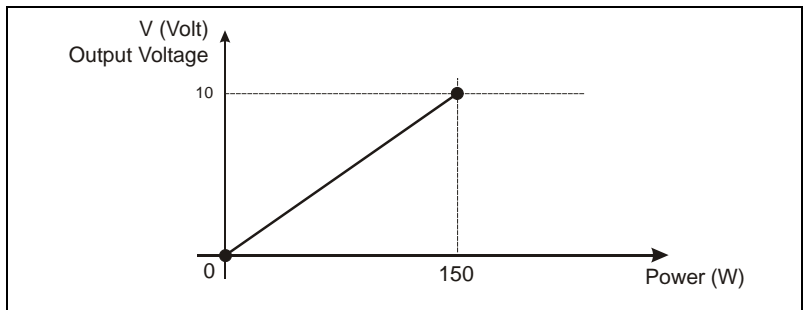

Figure 20 Diagram 2 – Programmable analog output related to power

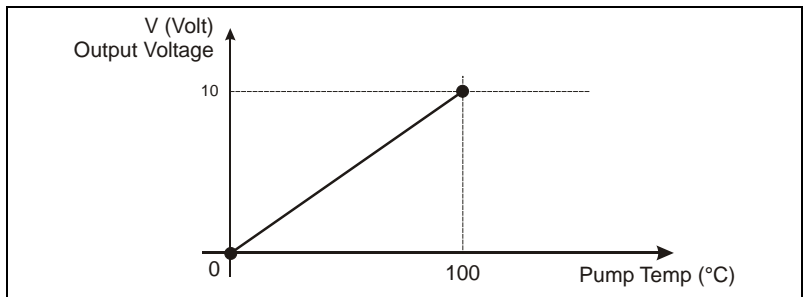

Figure 21 Diagram 3 – Programmable analog output related to pump temperature

Pump Connector

The controller is equipped with a 5 meter long cable. The following figure shows the controller output connector configuration where pins:

- **A-F** = pump temperature sensor
- **B-C-D** = 76 V AC 3-phase output to pump motor stator
- **E** = EARTH PROTECTION

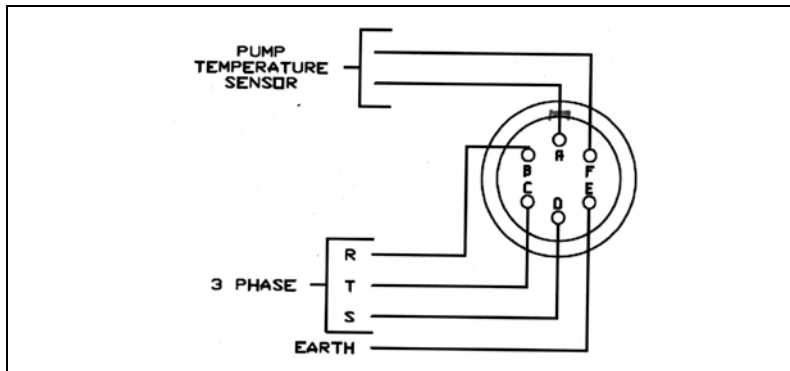

Figure 22 Controller-to-Pump Connector

J5 – Gauge Connector

This connector is available to connect the Agilent active gauges. The controller recognizes automatically the gauge connected by reading the signal “identification” in the connector. Following table shows all supported gauges:

Gauge model	Name showed in the display
FRG 700/702	FRGa
IMG 500	IMG
PVG 500/502	PVGa
IM 500	IM
CDG 500 T1000	CDG3
CDG 500 T0100	CDG2
CDG 500 T0010	CDG1
CDG 500 T0001	CDG0

The controller gives the error “gauge error” if the gauge connected is not supported. The pressure can be read via display, serial line (win. 224) or REMOTE I/O on Programmable Analog Out.

If the Programmable Analog Output is configured to show the pressure read by an external gauge, the controller doesn't replicate exactly the signal coming from the gauge; it converts the gauge signal in the range from 0 to 10V.

The conversion formula is the following:

$$V_{out} = \frac{V_g - V_{g_min}}{V_{g_max} - V_{g_min}} \times 10$$

Where:

V_g is the gauge output voltage;

V_{out} is the Analog Output voltage;

$V_{g_min} \div V_{g_max}$ is the gauge voltage measuring range (these values can be drawn from the gauge technical specifications).

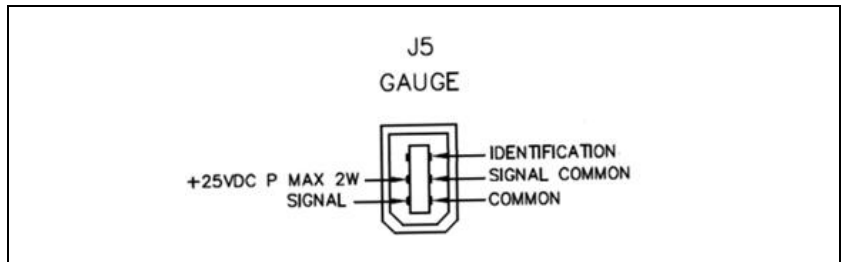

Figure 23 Gauge Connector

17 Technical Information

Programmable Analog Output Diagrams

With the serial communication you can use the following windows:

Win 163	Pressure measurement unit (0=mbar, 1= Pascal, 2=Torr)
Win 224	Pressure reading with the format X.X E XX
Win 257	Gauge status (read only): 0 → when a gauge is not connected 1 → when a gauge is connected 2 → when the pressure read is under range or when the gauge give an internal error 3 → when the pressure read is under range or when the gauge give an internal error 4 → when the “identification” is present but not known by the controller
Win 267	Gauge power (read/write): If you need to turn off the gauge at certain condition you can use this window 0 → gauge off 1 → gauge on (default) 2 → gauge normally off. It turns on when the set point 1 is activated. If the set point 1 type (win 101) is selected as “pressure” the gauge is always on. 3 → gauge normally off. It turns on when the set point 1 is activated. If the set point 2 type (win 171) is selected as “pressure” the gauge is always on. 4 → gauge normally off. It turns on when the set point 1 is activated. If the set point 3 type (win 101) is selected as “pressure” the gauge is always on.

The windows from 136 to 140 manage an additional set point
(set point 3) dedicated to turn ON or OFF the gauge (win 267=4)

Pump Driving

Typical pump driving chart start and normal operation with low or no gas load.

Stop Speed Reading and Active Stop

These functions can be activated by the Front Panel or serial line (Win 107 = Active Stop, Win 167 = Stop Speed Reading).

Active Stop brakes the pump using the motor. The Stop Speed reading reads the actual pump speed after a stop command.

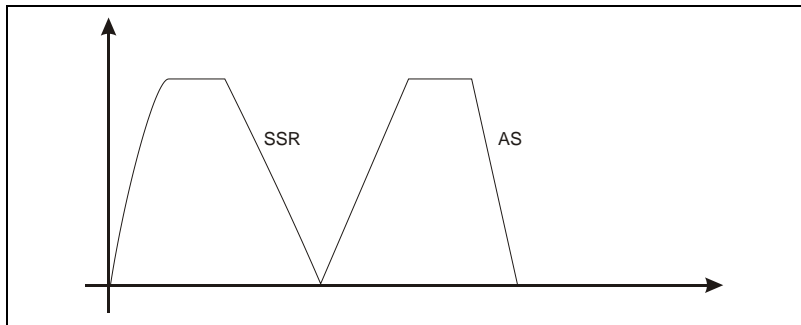

Figure 24 Diagram 5

J2 – Serial Connector

This connector provides the connection for RS-232 and RS-485 serial line.

J2 Pin-out:

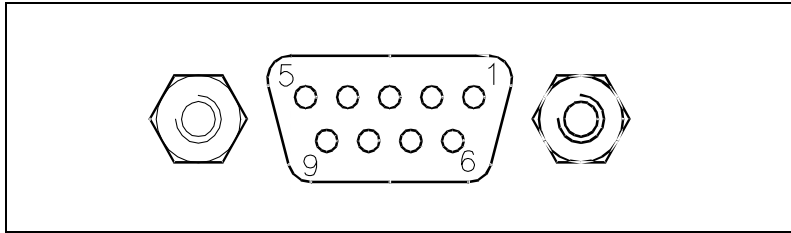

Figure 25 J2 Connector

Tab. 6

PIN N.	SIGNAL NAME
1	+5 V (OUT) (Reserved)
2	TX (RS-232)
3	RX (RS-232)
4	NC
5	GND
6	A+ (RS-485)
7	NC
8	B- (RS-485)
9	RESERVED

Connector Examples

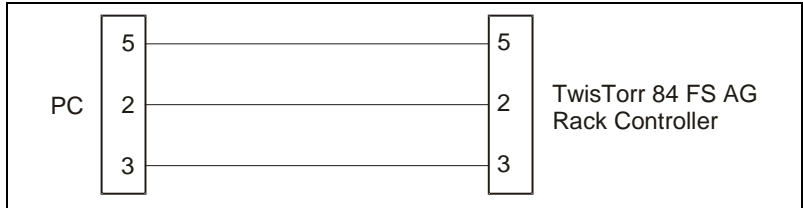

Figure 26 RS-232 Connection

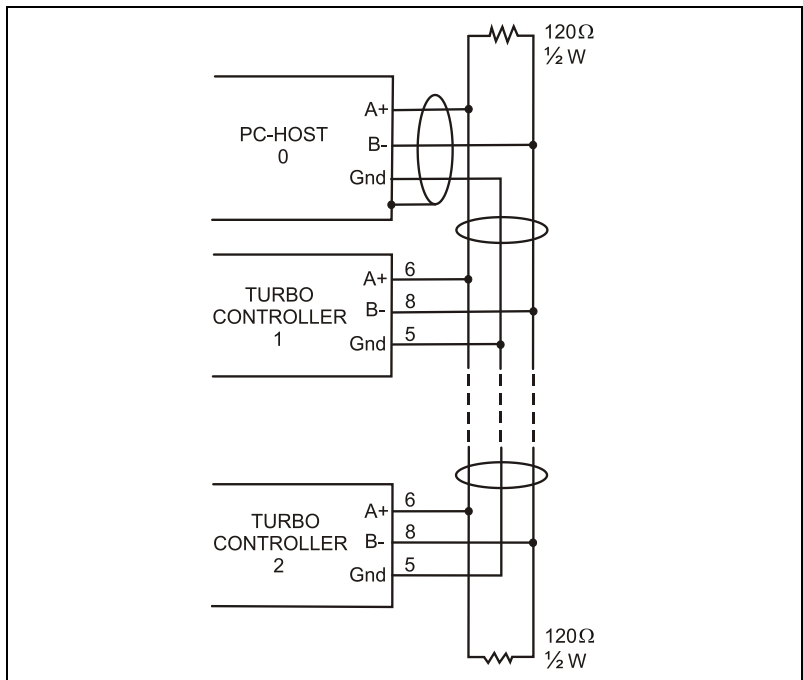

Figure 27 RS-485 Connection

17 Technical Information

J2 – Serial Connector

The communication port mating connector is supplied with the RS-232 PCB (AMP/Cannon or equivalent 15-pin "D" type male connector). For example, the Transmit data signal from controller (pin 2) must be connected to the host computer's receive data line (pin 2) and vice versa. Consult the host computer's instruction manual for its serial port connections.

NOTE

Agilent cannot guarantee compliance with FCC regulations for radiated emissions unless all external wiring is shielded, with the shield being terminated to the metal case on the D-subconnector. The cable should be secured to the connector with screws.

Serial Communication Descriptions

This unit can communicate by two different protocols:

- protocol (old system) "letter"
- "Window" protocol (new system)

These two protocols can be used as well with RS-232 or RS-485 media.

NOTE

Please use "Window" protocol for new development.

Letter Protocol Description

The default protocol is “Window”

Communication format:

- 8 data bit
- no parity
- 1 stop bit
- The baud rate is programmable via front panel from 600 to 9600 baud. The controller is factory-set for 9600 baud operation.

Communication protocol:

Host = Master

Controller = Slave

The communication is performed in the following way:

Host Controller

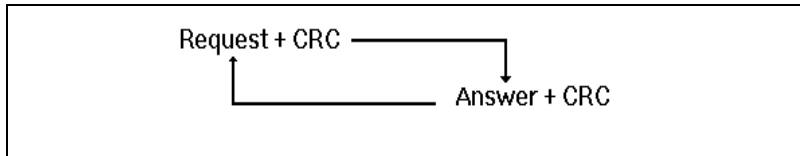

Request is an ASCII character identifying the action that must be performed by the controller or the requested information.

Allowed ASCII characters:

- "A" = START
- "B" = STOP
- "C" = Low Speed ON
- "D" = Low Speed OFF
- "E" = Request for operational parameters
- "F" = Pump times zeroing

17 Technical Information

Letter Protocol Description

- "G" = Parameters reading
- "H" = Parameters writing
- "I" = Request for operating status
- "J" = Request for numerical reading
- "K" = Request for counters reading.

CRC corresponds to the sum (with inverted sign) of all the preceding bytes.

e.g., the START command "A" in ASCII code = 41 inverted it will be: $FF + 1 - 41 = BF$.

Tab. 7

CHARACTER	ASCII	CONVERTED ASCII FOR CRC CALCULATION
"A"	41h	-
CRC	-	BFh
"B"	42h	-
CRC	-	BEh
"C"	43h	-
CRC	-	BDh
"D"	44h	-
CRC	-	BCh
"E"	45h	-
CRC	-	BBh
"F"	46h	-
CRC	-	BAh
"G"	47h	-
CRC	-	89h
"H"	48h	-
"I"	49h	-
CRC	-	B7h
"J"	4Ah	-
CRC	-	B6h

CHARACTER	ASCII	CONVERTED ASCII FOR CRC CALCULATION
"K"	4Bh	-
CRC	-	B5h
"ACK"	06h	-
CRC	-	FAh
"NACK"	15h	-
CRC	-	EBh

Answer = after a request from the host, the Controller will answer in one of the following ways:

- ACK
- NACK
- Message

When the Request is "A", "B", "C", "D", "F" the Controller will Answer the ACK or NACK.

When the Request is "E, the **Answer** will contain the complete set of the following parameters:

Tab. 8

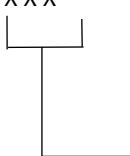
BYTES	MEANING
<div style="text-align: center;"> 1 MSB LSB -- X X X  </div>	0 = STOP 1 = WAITING INTERLOCK 2 = STARTING 3 = NORMAL OPERATION 4, 5 = HIGH LOAD 6 = FAILURE 7 = APPROACHING LOW SPEED
2 ÷ 5	Cycle Time
6 ÷ 9	Pump Life
10 ÷ 11	Pump Temperature
12	Current*

17 Technical Information
Letter Protocol Description

BYTES	MEANING
13	Voltage*
14 ÷ 17	Frequency
18 ÷ 19	Cycle #
20	R1 Status
21	R2 Status
22	CRC

*The values for current and voltage are given as numbers, scaled from 0 to 255, where 0 corresponds to 0 V and 255 to the full scale voltage (130 V) or current (2,5 A).

When the **Request** is "G", the **Answer** will contain a string of 11 characters with the following parameters:

Tab. 9

BYTES	MEANING
1-2	Pump cycles number (integer coded in 2 bytes)
3	Speed threshold
4-7	Run up time in seconds (long coded in 4 bytes)
8	Deat time (0 = NO 1 = YES)
9	Reserved
10	Soft Start mode (0 = NO 1=YES)
11	CRC

When the configuration parameters have to be changed, send a **Request** string with "H" characters of the following type:

"H" + data + CRC

The following parameters can be changed:

Tab. 10

BYTES	MEANING
1	Speed threshold
2-5	Run up time in seconds (long coded in 4 bytes)
6	Deat time (0 = NO 1 = YES)
7	Reserved
8	Soft Start mode (0 = YES 1 = NO)
9	CRC

When the **Request** is "I" (Status readings), the **Answer** will contain a string of 2 characters with the following parameters:

Tab. 11

BYTES	MEANING
1	<div style="display: flex; align-items: center;"> <div style="margin-right: 20px;"> <p>MSB LSB</p> <p>--XXXXXX</p> </div> <div> <p>0 = STOP</p> <p>1 = WAITING INTERLOCK</p> <p>2 = STARTING</p> <p>3 = NORMAL OPERATION</p> <p>4, 5 = HIGH LOAD</p> <p>6 = FAILURE</p> <p>7 = APPROACHING LOW SPEED</p> <p>R2 status 0 = OFF 1 = ON</p> <p>R1 status 0 = OFF 1 = ON</p> </div> </div>
2	CRC

17 Technical Information

Letter Protocol Description

When the **Request** is "J" (Numerical readings), the **Answer** will contain a string of 5 characters with the following parameters:

Tab. 12

BYTES	MEANING
1	Current (0-255 scaled)
2	Voltage (0-255 scaled)
3	Rotational speed KRPM
4	Pump temperature °C (0-254 temperature reading, 255 = fail)
5	CRC

When the **Request** is "K" (Counters readings), the **Answer** will contain a string of 11 characters with the following parameters:

Tab. 13

BYTES	MEANING
1-4	Cycle time
5-8	Pump life
9-10	Cycle number
11	CRC

On request a sample program in QBasic language is available by Agilent.

Window Protocol

Description

Communication Format

- 8 data bit
- no parity
- 1 stop bit
- baud rate: 600/1200/2400/4800/9600 programmable

Communication Protocol

The communication protocol is a MASTER/SLAVE type where:

- Host = MASTER
- Controller = SLAVE

The communication is performed in the following way:

- 1 the host (MASTER) send a MESSAGE + CRC to the controller (SLAVE);
- 2 the controller answer with an ANSWER + CRC to the host.

The MESSAGE is a string with the following format:

`<STX>+<ADDR>+<WIN>+<COM>+<DATA>+<ETX>+<CRC>`

Where:

NOTE

When a data is indicated between two quotes ('...') it means that the indicated data is the corresponding ASCII character.

When a number is indicated with 0x prefix it means it is an hexadecimal number (16 base coded).

17 Technical Information

Letter Protocol Description

<STX> (Start of transmission) = 0x02

<ADDR> (Unit address) = 0x80 (for RS 232)

<ADDR> (Unit address) = 0x80 + device number (0 to 31)
(for RS 485)

<WIN> (Window) = a string of 3 numeric character indicating the window number (from '000' to '999'); for the meaning of each window see the relevant paragraph.

<COM> (Command) = 0x30 to read the window, 0x31 to write into the window

<DATA> = an alphanumeric ASCII string with the data to be written into the window. In case of a reading command this field is not present. The field length is variable according to the data type as per the following table:

Tab. 14

Data Type	Field Length	Valid Characters
Logic (L)	1	'0' = OFF '1' = ON
Numeric (N)	6	',' ','0' ... '9' right justified with '0'
Alphanumeric (A)	10	from blank to '_' (ASCII)

<ETX> (End of transmission) = 0x03

<CRC> = XOR of all characters subsequent to <STX> and including the <ETX> terminator. The value is hexadecimal coded and indicated by two ASCII character.

The addressed SLAVE will respond with an ANSWER whose structure depends from the MESSAGE type. When the MESSAGE is a reading command, the SLAVE will respond transmitting a string with the same structure of the MESSAGE.

NOTE

Using the RS 485 interface, the message structure remains identical to the one used for the RS 232 interface, the only difference being that the value assigned to the ADDRESS <ADDR>

The controller can answers with the following response types:

Tab. 15

Response Type	Response Length	Response Value	Description
Logic	1 byte	-	after a read instruction of a logic window
Numeric	6 bytes	-	after a read instruction of a numeric window
Alphanumeric	10 bytes	-	after a read instruction of an alphanumeric window
ACK	1 byte	(0x6)	the command execution has been successfully completed
NACK	1 byte	(0x15)	the command execution has been failed
Unknown Window	1 byte	(0x32)	the specified window in the command is not a valid window
Data Type Error	1 byte	(0x33)	the data type specified in the command (Logic, Numeric or Alphanumeric) is not accorded with the specified Window
Out of Range	1 byte	(0x34)	the value expressed during a write command is out of the range value of the specified window
Win Disabled	1 byte	(0x35)	the specified window is Read Only or temporarily disabled (for example you can't write the Soft Start when the Pump is running)

17 Technical Information

Examples

Examples

Command: START

Source: PC

Destination: Controller

02	80	30	30	30	31	31	03	42	33
STX	ADDR	WINDOW			WR	ON	ETX	CRC	

Source: Controller

Destination: PC

02	80	06	03	38	35
STX	ADDR	ACK	ETX	CRC	

Command: STOP

Source: PC

Destination: Controller

02	80	30	30	30	31	30	03	42	32
STX	ADDR	WINDOW			WR	OFF	ETX	CRC	

Source: Controller

Destination: PC

02	80	06	03	38	35
STX	ADDR	ACK	ETX	CRC	

Command: SOFT-START (ON)

Source: PC

Destination: Controller

02	80	31	30	30	31	31	03	42	32
STX	ADDR	WINDOW			WR	ON	ETX	CRC	

Source: Controller

Destination: PC

02	80	06	03	38	35
STX	ADDR	ACK	ETX	CRC	

Command: SOFT-START (OFF)

Source: PC

Destination: Controller

02	80	31	30	30	31	30	03	42	33
STX	ADDR	WINDOW			WR	OFF	ETX	CRC	

Source: Controller

Destination: PC

02	80	06	03	38	35
STX	ADDR	ACK	ETX	CRC	

17 Technical Information

Examples

Command: READ PUMP STATUS

Source: PC

Destination: Controller (with address = 3)

02	83	32	30	35	30	03	38	37
STX	ADDR	WINDOW		RD	ETX	CRC		

Source: Controller (with address = 3 in stop status)

Destination: PC

02	83	3	3	3	3	3	3	3	3	3	3	03	3	3
		2	0	5	0	0	0	0	0	0	0		8	7
STX	ADDR	WINDOW		R D	DATA (STATUS)					ETX	CRC			

Command: READ SERIAL TYPE

Source: PC

Destination: Controller (with address = 3 in 485 mode)

02	83	35	30	34	30	03	38	31
STX	ADDR	WINDOW		RD	ETX	CRC		

Source: Controller

Destination: PC

02	83	35	30	34	30	31	03	42	30
STX	ADDR	WINDOW		RD	DATA	ETX	CRC		

Window Meanings

Tab. 16 Accessories and Spare Parts

N.	Read/ Write	Data Type	Description	Admitted Values
000	R/W	L	Start/Stop (in remote/ Front mode the window is a read only)	Start = 1 Stop = 0
001	R/W	L	Low Speed Activation	No = 0 Yes = 1 (default = 0)
008	R/W	L	Remote (default) or Serial configuration	Remote = 1 Serial = 0 (default = 1)
100	R/W	L	Soft Start (write only in Stop condition)	YES = 1 NO = 0
101	R/W	N	R1 Set Point type	0 = Frequency 1 = Power 2 = Time 3 = Normal (default = 3) 4 = Pressure (available only if the gauge is connected)
102	R/W	N	R1 Set Point threshold value (expressed in Hz, W or s)	(default = 900)
103	R/W	N	Set Point delay: time between the pump start and the set point check (seconds)	0 to 99999 (default = 0)
104	R/W	L	Set Point signal activation type: the signal can be "high level active" or "low level active"	0 = high level active 1 = low level active (default = 0)
105	R/W	N	Set point hysteresis (in % of value)	0 to 100 (default = 2)
106	R/W	L	Water cooling	0 = NO 1 = YES
107	R/W	L	Active Stop (write only in stop)	0 = NO 1 = YES
108	R/W	N	Baud rate	600 = 0 1200 = 1 2400 = 2 4800 = 3 9600 = 4

17 Technical Information

Examples

				(default = 4)
109	W	L	Pump life/ cycle time/ cycle number reset	To reset write '1'
110	R/W	L	Interlock type (default = 0)	Impulse = 0 Continuous = 1
111	R/W	L	Analog output type: output voltage signal proportional to frequency, power, temperature or pressure	0 = frequency 1 = power (default = 1) 2 = Pump temperature 3 = Pressure
117	R/W	N	Low Speed frequency (Hz)	1100 to rotational frequency setting (win 120) (default = 1100)
120	R/W	N	Rotational frequency setting (Hz)	Low speed frequency (win 117) to 1350 (default = 1350)
122	R/W	L	Set vent valve on/off (on = closed)	On = 1 Off = 0 (default = 1)
123	Reserved to Agilent service			
124				
125	R/W	L	Set the vent valve operation	Automatic = 0 (see note 1.) On command = 1 (see note 2.) (default = 0)
126	R/W	N	Vent valve opening delay (expressed in 0.2 sec)	0 to 65535 (corresponding to 0 to 13107 sec)
130	Reserved to Agilent service			
136	R/W	N	Gauge Set Point Type	0 = Freq 1 = Power 2 = Time 3 = Normal (default)
137	R/W	N	Gauge Set Point Value (Hz, W, s)	(default (867)
138	R/W	N	Gauge Set Point Mask (sec)	(default = 0)
139	R/W	L	Gauge Set Point Segnal Activation Type	0 = high level active (default) 1 = low level active
140	R/W	N	Gauge Set front Mysteresis (in % of R2 Valve)	(default = 2)
143	R/W	N	External Fan Configuration	0 = ON 1 = automatic 2 = serial (default = 0)

144	R/W	L	External Fan Activation	0 = OFF 1 = ON (default = 0)
147	R/W	N	Vent open time See "vent connector" paragraph	0 = infinite 1 bit = 0.2 sec
155	R	N	Power limit applied Read the maximum power deliverable to the pump	watt
157	R/W	N	Gas load type. Select the gas load to the pump	0 = N ₂ 1 = Argon
162	R/W	A	R1 Set Point Pressure Threshold Valid if min. 101 = 4 Format X.X EsXX Where X = 0 to 9 s = + or -	
163	R/W	N	Pressure unit of measure	0 = mBar 1 = Pa 2 = Torr
167	R/W	A	Stop speed reading Activates / deactivates the pump speed reading after Stop command	0 = disable 1 = enable
171	R/W	N	R2 Set Point Type	0 = Freq 1 = Power 2 = Time 3 = Normal (default = 3) 4 = Pressure (available only if the gauge is connected)
172	R/W	N	R2 Set Point Value (Hz, W, s)	
173	R/W	N	R2 Set Point Mask (sec)	
174	R/W	L	R2 Set Point Signal Activation Type	0 = high level active 1 = low level active
175	R/W	N	R2 Set Point hysteresis (in % of R2 Valve)	
176	R	A	R2 Set Point Pressure Threshold Valid if win 171 = 4 Format X.X EsXX Where: X= 0 to 9 s = + or -	
177	R/W	L	Start Output Mode	0 = Starting (Output ON only with pump Status = Starting) 1 = running (Output ON when the pump is running) (default -0)

17 Technical Information

Examples

181	R/W	N	Gas type	0 = not configured 1 = Nitrogen 2 = Argon 3 = Idrogen 4 =other
182	R/W	N	Gas correction	
200	R	N	Pump current in mA dc	
201	R	N	Pump voltage in Vdc	
202	R	N	Pump power in W (pump current x pump voltage duty cycle)	
203	R	N	Driving frequency in Hz	
204	R	N	Pump temperature in °C	0 to 70
205	R	N	Pump status	Stop = 0 Waiting intlk = 1 Starting = 2 Auto-tuning = 3 Braking = 4 Normal = 5 Fail = 6
206	R	N	Error code	Bit description: see the following figure
211	R	N	Controller Heatsink Temperature (°C)	
216	R	N	Controller Air Temperature (°C).	
224	R	A	Pressure reading Format = X.X E XX	
226	R	N	Rotation Frequency (rpm)	
257	R	N	Gauge status	0 = No gauge connected 1 = gauge connected 2 = Under range/gauge error 3 = over range/gauge error 4 = Rid unknown
267	R/W	N	Gauge power	0 = gauge off 1 = gauge 0n 2 = programmable power sp1 3 = programmable power sp2 4 = programmable power sp3
300	R	N	Cycle time in minutes (zeroed by the reset command)	0 to 999999
301	R	N	Cycle number (zeroed by the reset command)	0 to 9999

302	R	N	Pump life in hours (zeroed by the reset command)	0 to 999999
320 to 399	Reserved to Agilent service			
400	R	A	CRC EPROM (QE)	QE8XXXX (where "XXXX" are variable)
402	R	A	CRC Param. (PA)	PA8XXXX (where "XXXX" are variable)
404	R	A	CRC Parameter structure	"XXXX"
500	Reserved to Agilent service			
503	R/W	N	RS 485 address	0 to 31 (default = 0)
504	R/W	L	Serial type select	0 = RS 232 1 = RS 485 (default = 0)

NOTE

1. Automatic means that when the controller stops, the vent valve is opened with a delay defined by window n. 126; when the controller starts, the vent valve is immediately closed.
2. On command means that the vent valve is opened or closed by means of window n. 122.

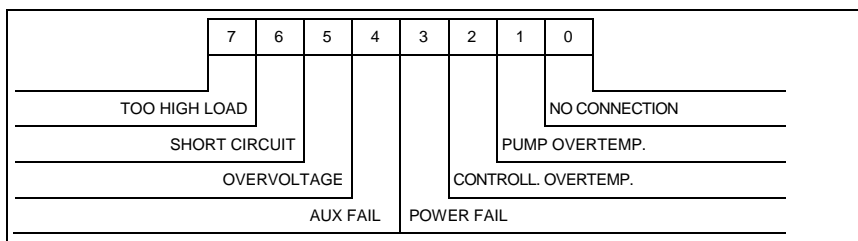

Figure 28 Window N. 206 Bit Description

How to Use by Front Panel

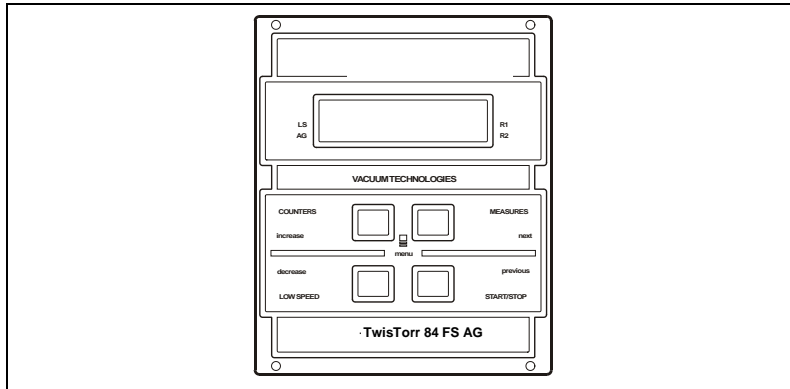

Figure 29

- **Start Stop and Reset Fail button**

Press once for the START command and again for the STOP command. In the case of controller's failure, press once to reset the fail condition.

NOTE

The front panel START/STOP function is available only if the controller is set to "FRONT mode". If it is set to "REMOTE mode", when the key is pressed an error message is shown indicating "COMMAND LOCKED IN REMOTE", if it is set to "SERIAL" mode, the "COMMAND LOCKED IN SERIAL MODE" error message is displayed. The "Reset Fail" function is always available regardless of controller mode.

- **Low Speed**

Press once to activate the LOW SPEED command; press again to de-activate.

NOTE

The front panel LOW SPEED function is available only if the controller is set to "FRONT"; otherwise an error message is returned. If it is set to "REMOTE" mode, the COMMAND LOCKED IN REMOTE error message is displayed while if it is in "SERIAL" mode the "COMMAND LOCKED IN SERIAL MODE" error message is returned.

- **Counters**

Pressing the key once, the following information is displayed:

			C	Y	C	L	E		X	X	X	X			
		T	I	M	E				X	X	X	X	X	m	

Where:

CYCLE XXXX Number of start/stop cycles

TIME XXXXXm Time of last cycle (minutes)

Pressing twice, the following is displayed:

			P	U	M	P		L	I	F	E				
				X	X	X	X	X	X	h					

PUMP LIFE

XXXXXX total operating time (hours) of the pump

Pressing a third time, the following message is displayed:

	M	N	:		X	X	X	X	X	X	X	X	X	
	S	N	:		Y	Y	Y	Y	Y	Y	Y	Y	Y	

MN Model Number of the controller

SN Serial Number

By pressing the key again, the display returns back to the main screen.

- **Measures**

Pressing once, the following is displayed:

P	=	X	X	X	W					X	X	X	X	H	z
					T	=	X	X	°	C					

17 Technical Information

How to Use by Front Panel

Where:

P = XXX W is the current power supplied to the pump

T = XX °C is the current temperature of the pump

XXXX Hz is the driving frequency of the pump. This value is set by default to 1350 Hz but can be modified by the user according to needs, proceeding as described in the “PROGRAMMING” paragraph. The unit of measurement (HZ / Krpm, default = Hz) is selected by the user from the INPUT/OUTPUT->SPED menu.

If the SOFT-START function (PUMP SETTING menu ' SOFTSTART) is active and the pump is ramping, indication of the speed of rotation is replaced with a bargraph that indicates the soft-start step in course and the total number of steps to be performed. On completion of the soft-start ramp, the bargraph is replaced with indication of the frequency of rotation of the pump

Pressing twice, the following is obtained:

N	O	R	M	A	L					X	X	X	X	H	z
	I	=	X	.	X	X	A		V	=	X	X	X	V	

Where:

NORMAL: indicates the pump status

XXXHz: is the driving frequency of the pump (for further details please see the description “Pressing once” the **Measures** key)

I=X.XXA: indicates the current absorbed by the pump

V= XXX V: indicates the pump driving voltage

Pressing 3 times, the following is obtained:

P	=	X	X	X	W					X	X	X	X	H	z
		X	.	X	X	E	-	Y	Y	m	B	a	R		

X	.	X	E	-	Y	Y	m	B	a	r		Z	Z	Z	Z
	P	=	X	X	X	W			X	X	X	X	H	z	

Where:

P= XXXW: indicates the current power supplied to the pump

XXXHz: is the driving frequency of the pump (for further details please see the description “Pressing once” the **Measures** key)

X.XE-YYmBar: indicates the pressure currently measured by the gauge.

ZZZZ: indicates the kind of gauge (see table of gauge supported in the gauge chapter)

Other possible indications:

P	=	X	X	X	W					X	X	X	X	H	z
		G	A	U	G	E		E	R	R	O	R			

Where:

GAUGE_ERROR: gauge not connected or broken

P	=	X	X	X	W					X	X	X	X	H	z
		P	R	E	S	S	U	R	E		U	N	D	E	R

Where:

PRESSURE UNDER: indicates that the pressure read is below the minimum measurement threshold set.

P	=	X	X	X	W					X	X	X	X	H	z
		P	R	E	S	S	U	R	E		O	V	E	R	

Where:

PRESSURE OVER: indicates that the pressure measured is above the maximum measurement threshold set.

The unit of measurement of the pressure can be selected (GAUGE menu’ Unit) from “mBar”, “Pa”, “torr”

Pressing 4 times returns to the following screen page:

N	O	R	M	A	L					X	X	X	X	H	z
	X	X	X	X	X	X	X	X	X	X	X	X	X	X	

17 Technical Information

How to Use by Front Panel

Where:

NORMAL: indicates the operating regime of the pump

XXXHz: is the driving frequency of the pump (for further details please see the description “Pressing once” the **Measures** key)

The operating mode of the controller is shown at the bottom in the center. This may be:

FRONT: front mode (the controller accepts START/STOP and LOW SPEED commands from the front panel)

REMOTE: remote mode (the controller accepts START/STOP and LOW SPEED commands via the rear connector)

RS 232: the controller accepts commands from the serial port according to the RS 232 standard.

RS-485 [XX]: the controller accepts commands from the serial port in RS-485 mode with address XX (XX from 0 to 31)

PROFIBUS [YYY]: the controller accepts commands from the PROFIBUS port with address YYYYY

Black rectangles as shown below may be displayed at any time in the first and last box of the bottom line of the display (opposite the LS / AG / R1 / R2 captions). The meaning of these rectangles is as follows:

LS ’ the controller is at LOW SPEED

AG ’ the Gauge is connected to the controller

R1 ’ relay (set point) R1 is active

R2 ’ relay (set point) R2 is active

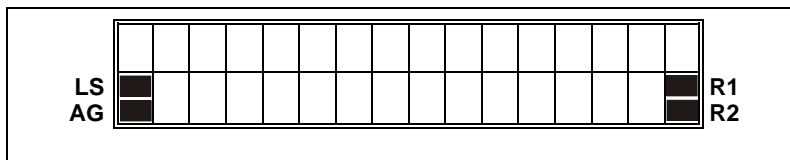

Figure 30

Use

General

Make all vacuum manifold and electrical connections and refer to TwisTorr pump instruction manual before to operating the TwisTorr controller.

WARNING!

Refer to the relevant pump manual to operate it in a safe way before starting.



NOTE

The input signal J1 interlock should be left in position including the shipping links if no external connections are made. The forepump and the TwisTorr pump can be switched on at the same time.

Startup

- Plug the controller power cable into a suitable power source. The display lights up for approx. 2 seconds and shows:

				A	U	T	O	T	E	S	T				
							O	K							

- After 2 seconds, the display shows the following screen page:

S	T	O	P						H	z
				F	R	O	N	T						

NOTE

If the pump is not connected, the display will be as follows:

C	H	E	C	K		C	O	N	N	E	C	T	I	O	N
			T	O		P	U	M	P						

- Pressing the START button, the pump is started and the display shows the following screen page.

S	T	A	R	T	I	N	G			X	X	X	X	H	z
					F	R	O	N	T						

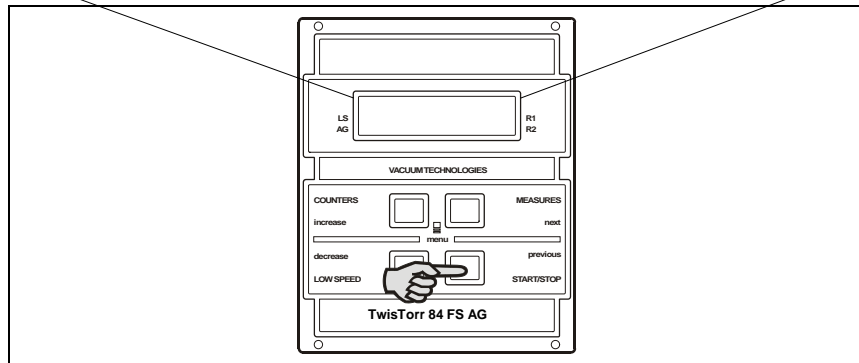

Figure 31

This screen page will be visible throughout the acceleration phase the pump. The increasing value of the rotational frequency will be displayed in the boxes marked X; the user may decide to express this value in Hz (default) or in KRMP.

Once operating speed has been reached, the following screen page is displayed:

N	O	R	M	A	L					1	3	5	0	H	z
					F	R	O	N	T						

If the LOW SPEED key is pressed, the above screen page changes to:

B	R	A	K	I	N	G				X	X	X	X	H	z
					F	R	O	N	T						

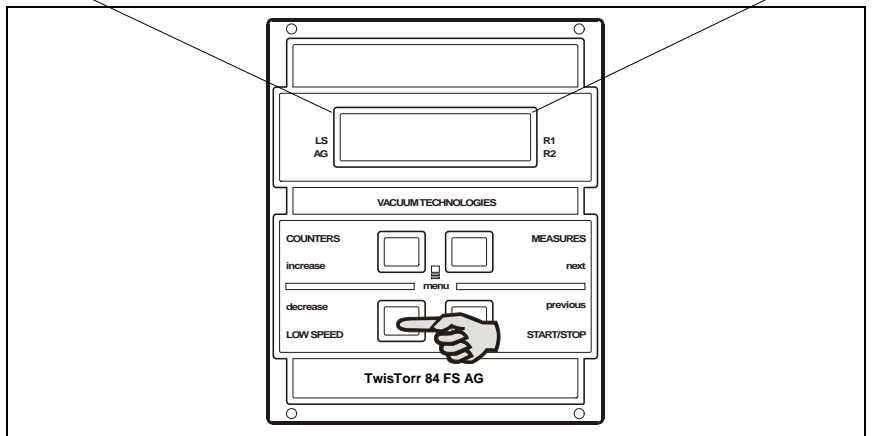

Figure 32

The following screen page is displayed on reaching the pre-established speed:

17 Technical Information

Use

N	O	R	M	A	L					1	3	5	0	H	z
					F	R	O	N	T						

The rotation value set in both NORMAL and LOW SPEED mode can be modified by the user as described in the Programming section of this manual.

- Press the MEASURES push button: the display shows:

P	=		5	0	W					1	3	5	0	H	z
					T	=	4	5	°	C					

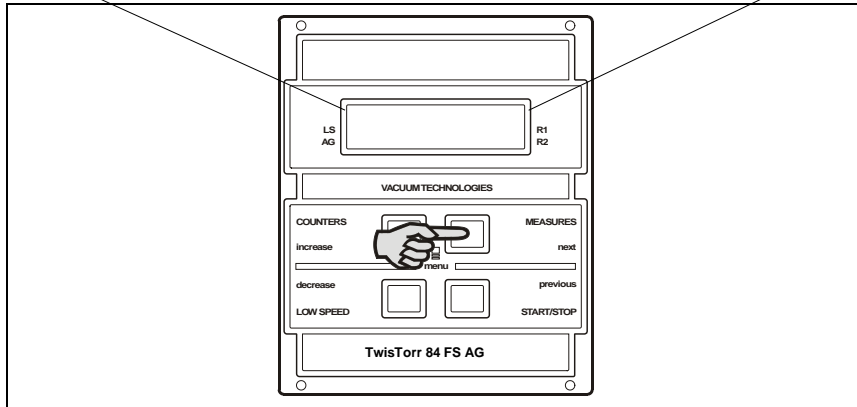

Figure 33

Where:

P = is the DC power drawn by the pump (controller display range 0 to 999 Watt)

Hz = is the rotational speed of the pump as a function of the controller output frequency

°C = is the temperature of the outer ring of the upper bearing (controller display range 00 to 99 °C)

- Pressing MEASURES key twice, the following screen page is displayed:

N	O	R	M	A	L					1	3	5	0	H	z
	I	=	1	.	2	0	A		V	=		4	2	V	

Where:

I is the current supplied by the controller to the pump at that precise moment.

V is the voltage at which the controller is powering the pump at that moment

- Pressing the MEASURES key three times, with the GAUGE connected and functioning, the following screen page is displayed:

7	.	4	E	-	0	5	m	B	A	r		X	X	X	X
	P	=		5	0	W			1	3	5	0	H	z	

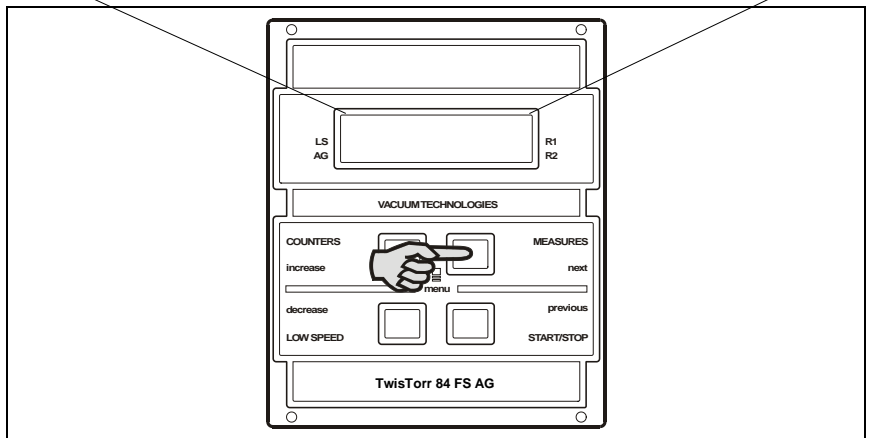

Figure 34

17 Technical Information

Use

Where:

mBar shows the pressure value measured

XXXX shows which gauge is connected

The following messages may be displayed instead of the pressure:

GAUGE ERROR: indicates that the GAUGE is not identified

PRESSURE UNDER: indicates that a pressure is below the minimum threshold

PRESSURE OVER: indicates that a pressure is exceeding the maximum threshold

- Pressing the COUNTERS key, the following is obtained:

			C	Y	C	L	E		X	X	X	X			
			T	I	M	E			X	X	X	X	X	m	

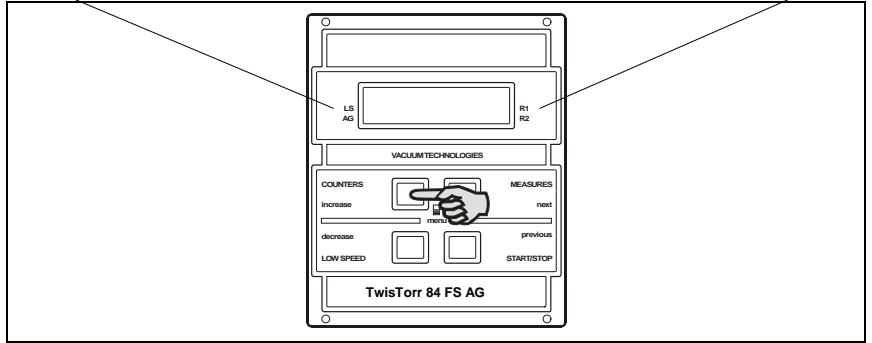

Figure 35

Where:

CYCLE XXXX Number of start/stop cycles

TIME XXXXXm Time of last cycle (minutes)

Pressing again:

			P	U	M	P		L	I	F	E			
			X	X	X	X	X	X	X	h				

Where:

PUMP LIFE XXXXXX total operating time (hours) of the pump

Programming

Configuration Menu

To access the configuration menu, press the COUNTERS + MEASURES buttons at the same time for at least 2 sec.

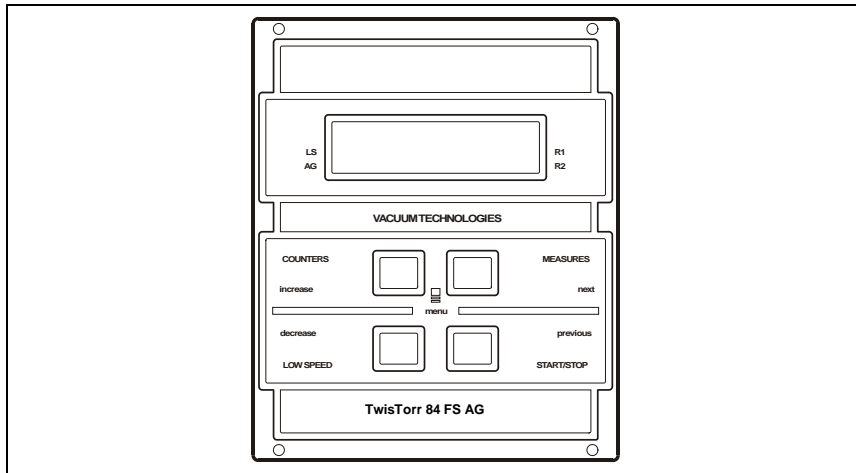

Figure 36

In programming mode, the meaning of the 4 buttons changes as follows:

- **COUNTERS/LOW SPEED** speed become “**INCREASE** and **DECREASE**” and make it possible to select the next or previous value of a parameter (in the case of compulsory parameters) or to increase/decrease the individual digit of a parameter (in the case of numeric parameters)
- The “**MEASURES** and **START/STOP**” buttons become “**NEXT** and **PREVIOUS**” and make it possible to select the next parameter (or next digit of a numeric parameter) or previous parameter.

Switching from one parameter to the next (using the “**NEXT**” key) indicates confirmation of any changes made to the specific parameter. If the changes cannot be accepted by the controller, the “**Data out of limits**” error message is displayed, the changes are cancelled and the value of the parameter prior to the modification is repropose.

Switching from a parameter to the previous parameter (using the “**PREVIOUS**” key) indicates the intention to abort any changes made to the specific parameter. Abort is indicated by the caption “**Changes aborted**” that is displayed for approx. 1 second before moving to the previous parameter.

The configuration environment has a tree-like structure and permits “circular” navigation; on reaching the end of a branch, the user is returned automatically to the start of this. Navigation can proceed in a forwards (**NEXT** button) or backwards (**PREVIOUS** button) direction

It is possible to enter a sub-branch by pressing the “**INCREASE**” button. If no buttons are pressed for more than 1 minute, the controller automatically quits the programming environment canceling any modifications made to the current parameter.

The figure below shows the first level of the configuration menu and the links to the respective second level menus (indicated below).

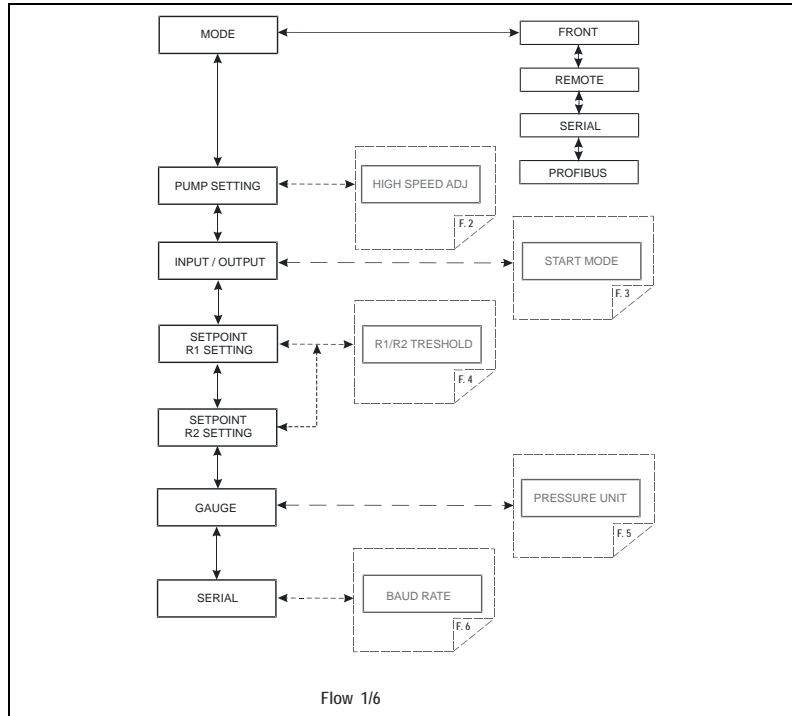
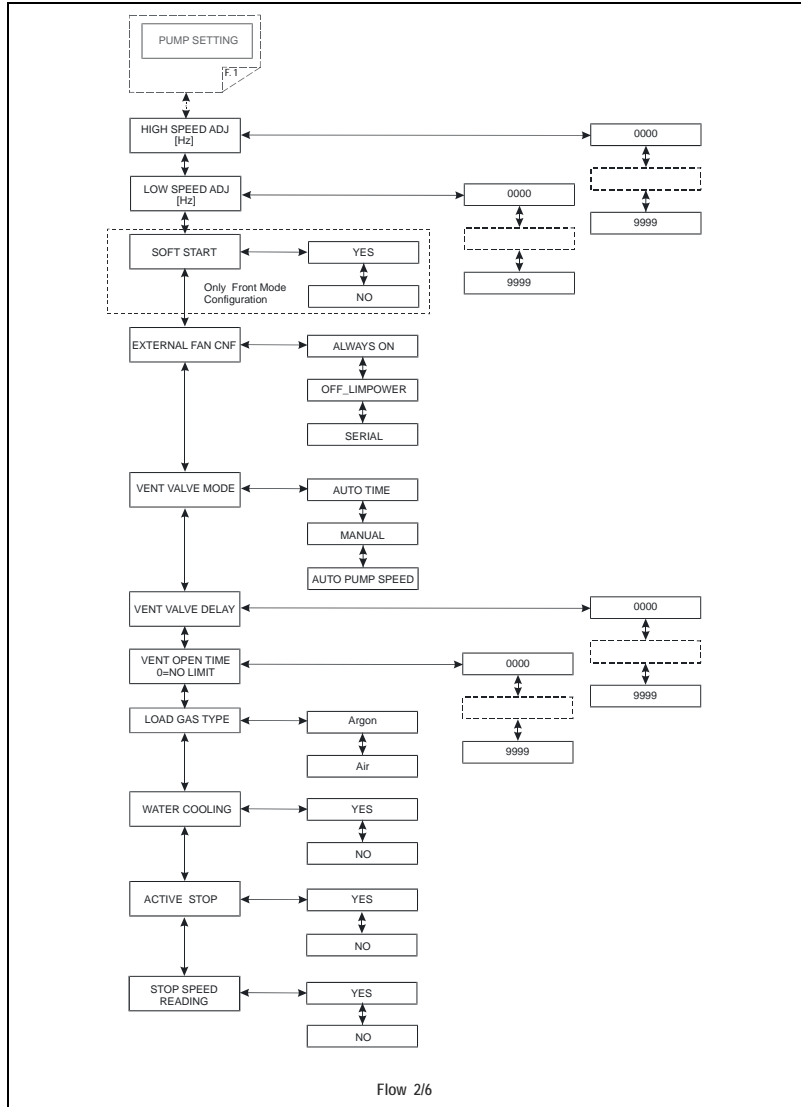

Figure 37 Menu structure

Mode Menu

- **MODE:** permits selection (see Flow 1/6) of the operating mode of the controller from those indicated below:
 - **FRONT:** accepts commands from the front panel
 - **REMOTE:** accepts commands from the remote input connector
 - **SERIAL:** accepts commands from the serial interface (or Profibus interface if present)
 - **PROFIBUS:** this operating mode is present only if the Profibus interface is installed on the controller

Pump Setting Menu



Flow 2/6

Figure 38 Pump setting menu

This menu contains all the parameters that have a direct effect on driving of the pump.

- **HIGH SPEED:** Sets (in Hz) the speed of rotation of the pump when the low-speed function is not active.
- **LOW SPEED:** Sets (in Hz) the speed of rotation of the pump when the low-speed function is active.
- **SOFT START:** enables (YES) or disables (NO) the soft start function. This parameter is visible only if the controller is configured in FRONT mode.
- **EXTERNAL FAN CNF:** Makes it possible to select driving mode of the external cooling fan. Possible options:
 - ALWAYS ON: the cooling fan is always ON
 - OFF_LIMPOWER: 10 seconds after the pump has reached NORMAL status, the fan is switched off and the driving power of the pump is reduced to 50 W
 - SERIAL: the cooling fan is controlled directly via the serial port.
- **VENT VALVE MODE:** makes it possible to select driving of the vent valve
 - AUTO TIME: the valve is controlled by the controller
 - MANUAL: the valve is controlled by the serial port.
 - AUTO PUMP SPEED: the valve is controlled by the controller its king into account the pump's deceleration.
- **VENT VALVE DELAY:** Sets the delay, expressed in seconds, between stopping of the pump and opening of the vent valve.
- **VENT VALVE OPEN TIME:** sets the time, expressed in seconds, of opening of the vent valve. Enter 0 if the valve is to be kept open indefinitely (until the next start).
- **LOAD GAS TYPE:** selects the type of gas used in the process. Therefore, the controller limits the power supplied to the pump according to the setting of this parameter.
- **WATER COOLING:** indicates whether the pump is cooled with water or not. The controller limits the power supplied to the pump according to this setting.

- **ACTIVE STOP:** enables (YES) or disables (NO) active braking.
- **STOP SPEED READING:** enables (YES) or disables (NO) the pump rotational frequency reading function also during the slowing phase that follows a stop command

Input/Output Menu

This menu contains parameters that determine the operating mode of the inputs and outputs of the controller.

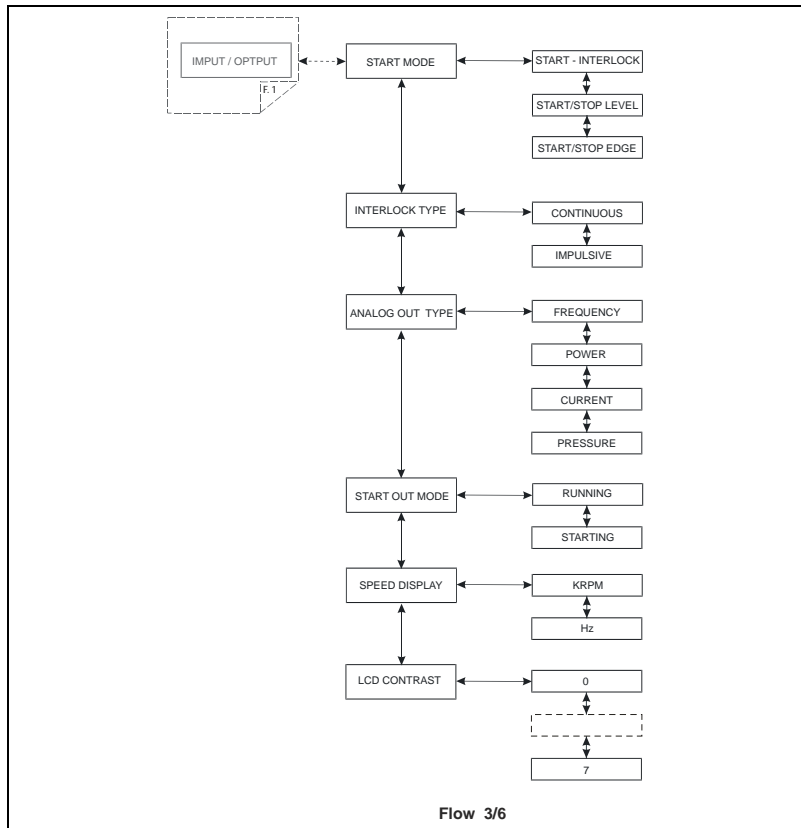

Figure 39 I/O menu

- **START MODE:** Permits selection of one of the three types of functioning of the START/STOP and INTERLOCK inputs:
 - **START/INTERLOCK:** The pump is started if the START/STOP input is activated and is stopped if the START/STOP input is de-activated. The interlock input must be constantly active (INTERLOCK TYPE parameter = continuous) or may be active only at the time of starting (INTERLOCK TYPE parameter = impulsive)
 - **START/STOP LEVEL** The START/STOP input acts as only START command (active on the level) The INTERLOCK input acts as STOP command (active on the level).
In the case of concurrent activation of the two inputs, the STOP command takes priority
 - **START/STOP EDGE** The START/STOP input acts as START command (active on the edge)
The INTERLOCK input acts as STOP command (active on the edge).
- **INTERLOCK TYPE:** This parameter is displayed only when the previous parameter (START MODE) is equal to START/INTERLOCK and permits selection of one of the following two operating modes of the INTERLOCK input:
 - **CONTINUOUS:** the INTERLOCK input must be active continuously so that the pump can be driven by the controller. If, with the controller in start, the input INTERLOCK is de-activated, the controller switches to WAITING INTERLOCK status and interrupts driving of the pump
 - **IMPULSIVE:** it is sufficient for the input to be active when the START command is sent to the pump. Subsequently, the input can also be de-activated. If the interlock is not active when the pump is started, the controller switches too WAITING INTERLOCK status.

- **ANALOG OUT TYPE:** permits selection of the type of signal to be sent to the programmable analogue output. One of the following signals can be selected:
 - **FREQUENCY:** the drive frequency of the pump is shown
 - **POWER:** the power supplied to the pump is shown
 - **TEMPERATURE:** the temperature of the pump is shown
 - **PRESSURE:** the pressure read by the gauge is shown.
- **START OUT MODE:** Selects the operating mode of the START output. Possible options:
 - **RUNNING:** the output is active when the pump is driven
 - **STARTING:** the output is active only during acceleration ramp-up.
- **SPEED OUT MODE (KRPM/Hz):** permits selection of the unit of measurement of the speed of rotation shown on the display of the controller.
This setting acts only on the measurement shown on the display. Possible options:
 - **KRPM**
 - **Hz**
- **LCD CONTRAST:** selectable from 0 to 7.

Setpoint R1 and Setpoint R2 Submenus

This submenu contains the settings relating to the output with relay R1 and R2 (if it is connected a gauge it will present also the settings for the set point 3).

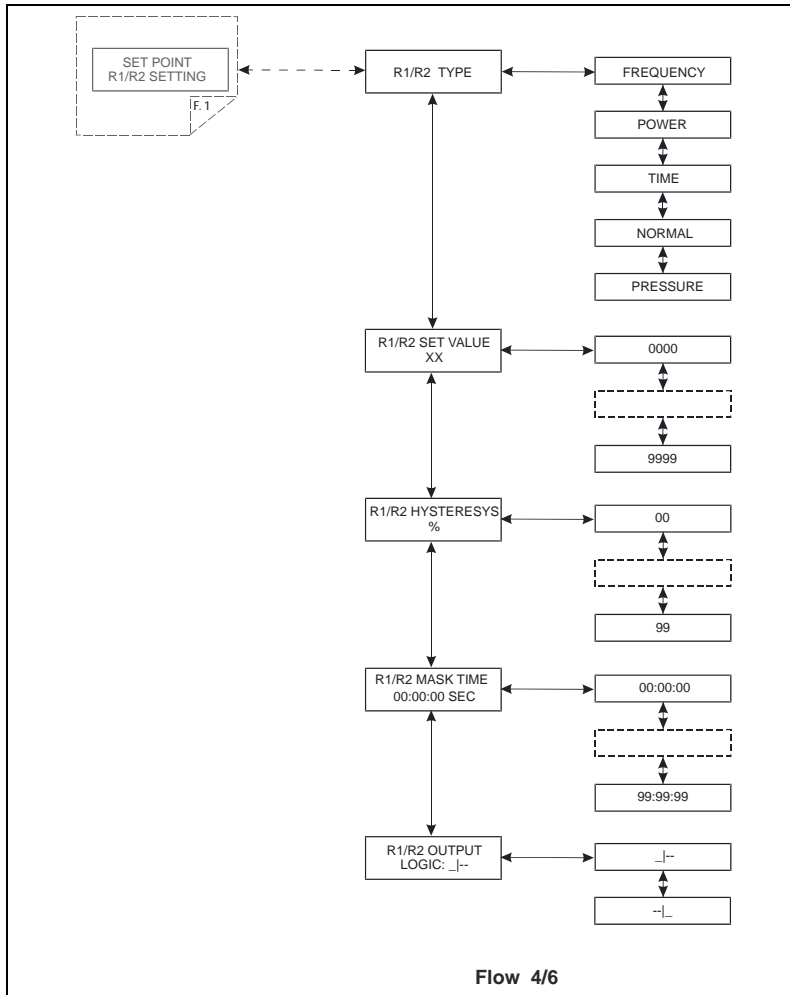

Figure 40 Setpoint menu

- **R1 (R2) TYPE:** selects the type of reference measurement to drive the relay. Possible types:
 - Frequency: driving frequency of the pump
 - Power: power supplied to the pump
 - Time: time from start
 - Normal: achievement of normal condition
 - Pressure: pressure read by the gauge, if present
- **R1 (R2) SET VALUE:** Sets the reference value at which the relay R1 (R2) is activated. This parameter has no effect if NORMAL (previous parameter) is selected as SETPOINT TYPE.
- **R1 (R2) HISTERESYS:** Sets, in percentage, the hysteresis of the relay
- **R1 (R2) MASK TIME:** sets the masked time (in hh:mm:ss), measured from start, within which the SETPOINT R1 (R2) is not driven even if the threshold value has been reached. This parameter is not available if SETPOINT TYPE is set to NORMAL
- **R1 (R2) OUTPUT LOGIC:** Selects the control logic of the SETPOINT output.
 - positive logic (the relay is energized when the measurement exceeds the reference)
 - negative logic (the relay is energized when the measurement is below the reference)

Gauge Menu

This menu contains the parameters relating to functioning of the active gauge.

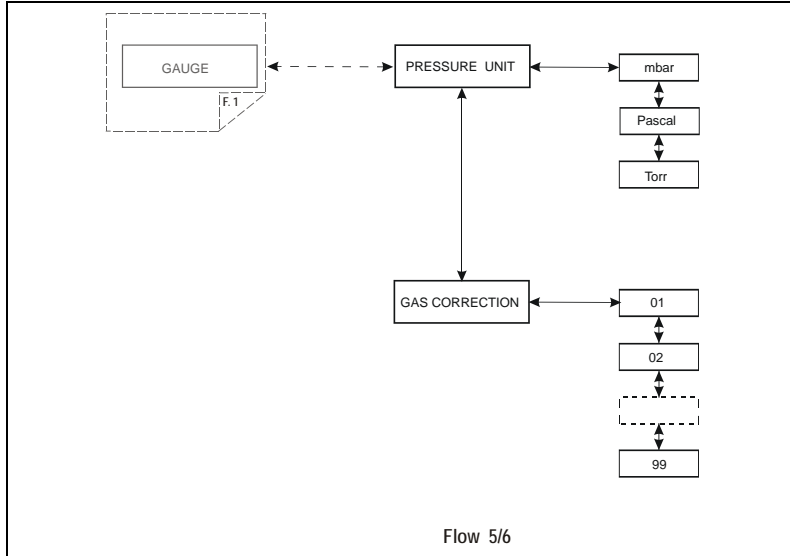

Figure 41 Gauge menu

- **PRESSURE UNIT:** selects the unit of measurement of the pressure used to show this on the display, for display on the serial line and for setting of the setpoint and autopressure thresholds. Possible options:
 - mbar
 - Pascal
 - Torr

GAUGE MODEL ID: it shows the gauge model identified by the controller.

If there are more model with the same identification the user can select the right gauge connected.

- **GAS TYPE :** sets the gas type:
 - 0 : not configured
 - 1 : Nitrogen
 - 2 : Argon
 - 3 : Idrogen
 - 4 : Other
- **CORRECTION :** if it is selected the gas type 4 (Other) you can set the correction factor of the pressure measurement for this kind of gas. The pressure indicated by the instrument is equal to:
 $P \text{ indicated} = P \text{ measured} \times \text{Gas correction} / 10$

Serial Menu

This menu contains the settings for management of the RS-232/RS-485 serial line.

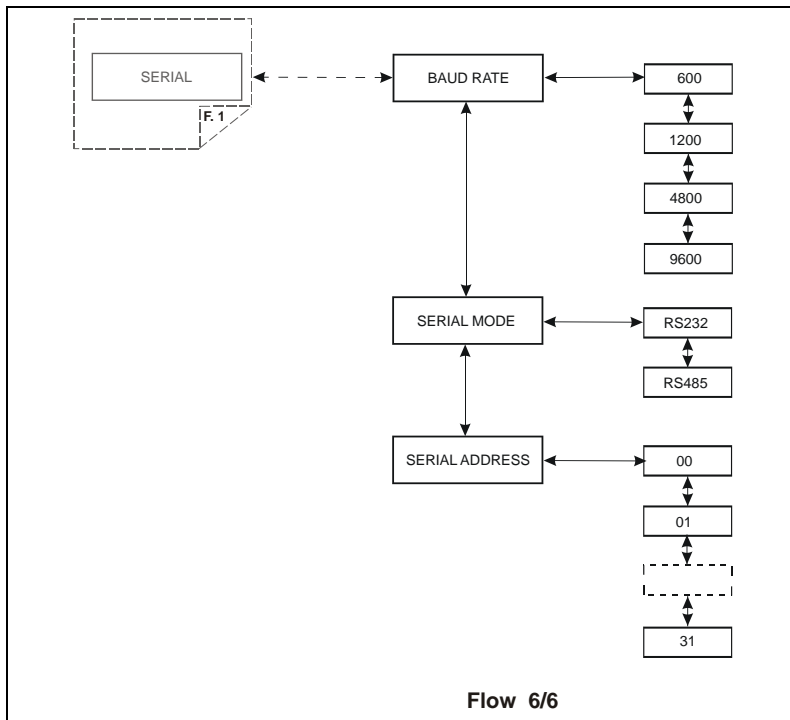

Figure 42 Serial menu

- **BAUD RATE:** permits selection of the communication speed selecting this from 600, 1200, 4800, 9600 baud
- **SERIAL MODE:** permits setting of the type of interface to RS-232 (point to point) or RS-485 (multidrop)
- **SERIAL ADDRESS:** sets the address of the node in the case of the RS-485 interface. This parameter is not visible if the RS-232 is selected.

How to Use by Remote I/O

- 1 Power ON the controller
- 2 Press the “COUNTERS” and “MEASURES” button together.
- 3 Select MODE = REMOTE from the “INPUT/OUTPUT” menu
- 4 Exit from configuration menu
- 5 Connection example: (see Fig. 44)

How to Use in Serial Mode

- 1 Power on the controller
- 2 Connect the serial cable
- 3 Select by front panel if you want to work in 232 or 485, and if necessary, the serial address.
- 4 Select SERIAL from the INPUT/OUTPUT menu
- 5 Open the T-PLUS software (see orderable parts table)
- 6 Ready to operate by SERIAL connections.

17 Technical Information
How to Use in Serial Mode

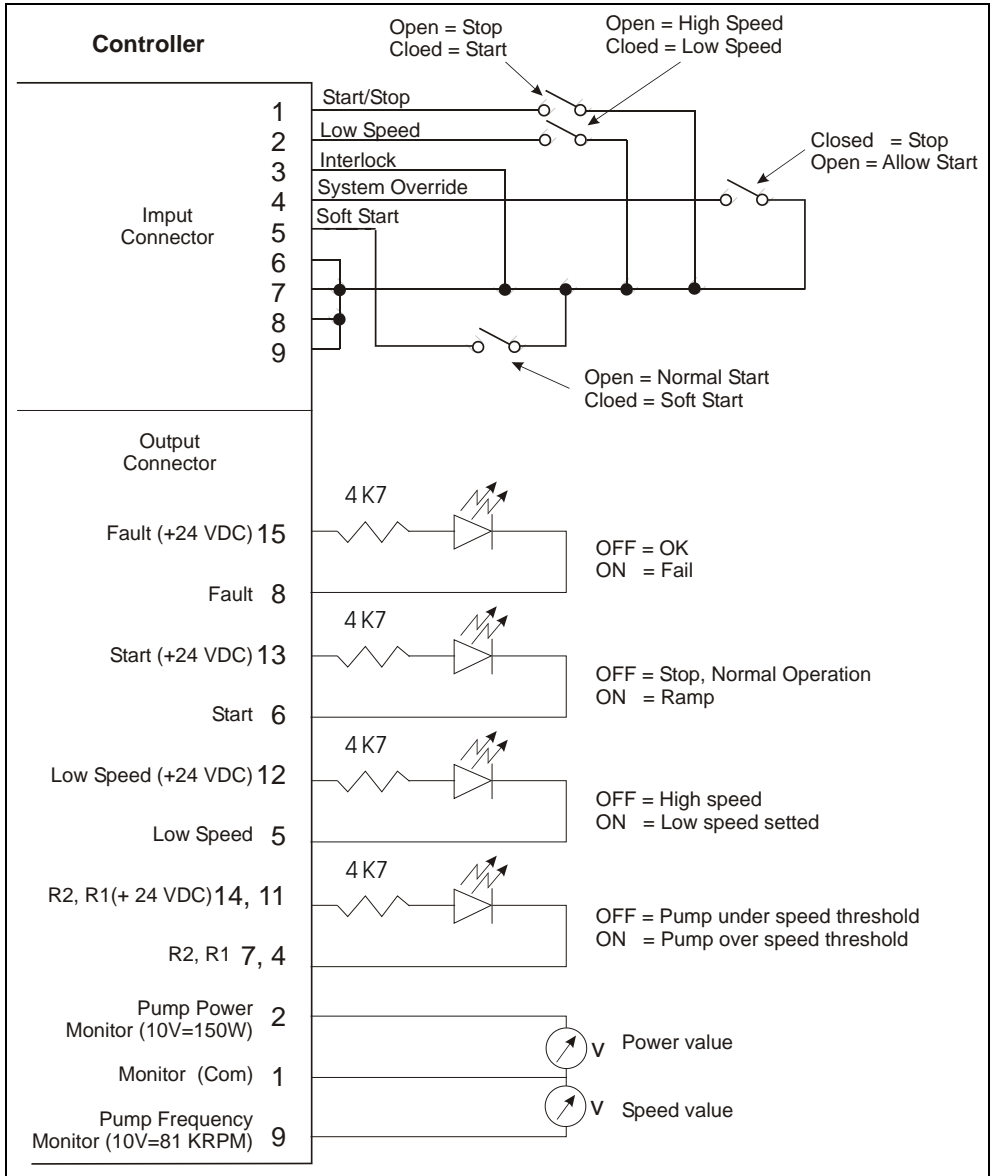

Figure 43 Connection example

Profibus Option

General

The Profibus option allow to communicate with the controller as Profibus DP slave device.

The option works as a bi-directional bridge between the Profibus network and the Agilent turbo controller internal link. The interface provides input data (measures) and output data (commands) to the controller, and in addition provides standard and user related diagnostics, in order to allow the user to manage the exceptions.

Installation

This is a factory installed option on controllers with the part number X3508-64002.

The Profibus connector pin-out is reported in the following figure. Please in order to obtain best performance use Profibus certified cables.

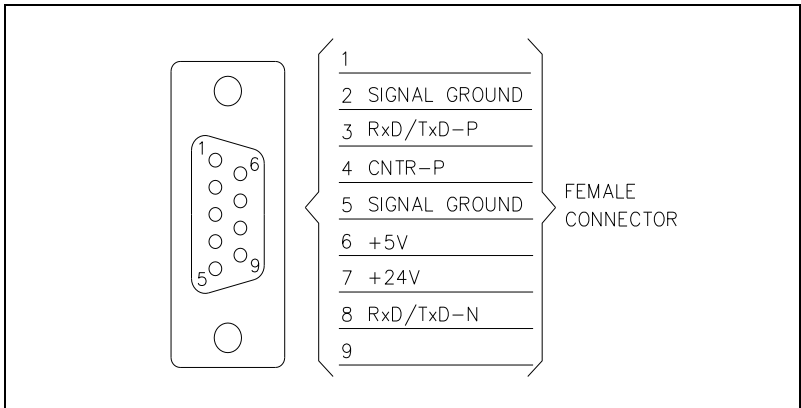

Figure 44 Profibus connector

Configuration

Before power-on the controller set the ProfiBus address by the 2 rotary switches.

Up to 126 different addresses (from 0 to 125) can be selected. The address value sets by the 2 switches is expressed in hexadecimal notation, so value from 00 to 7D are permitted; this setting is read by the interface during the power-on phase, so any change of the switch position after the power-on is ignored.

Software Operation and State Machine

From the software point of view, the interface can be seen as two devices (one for ProfiBus and the other for the internal link) linked together.

Each device has its own state machine to manage the device operation.

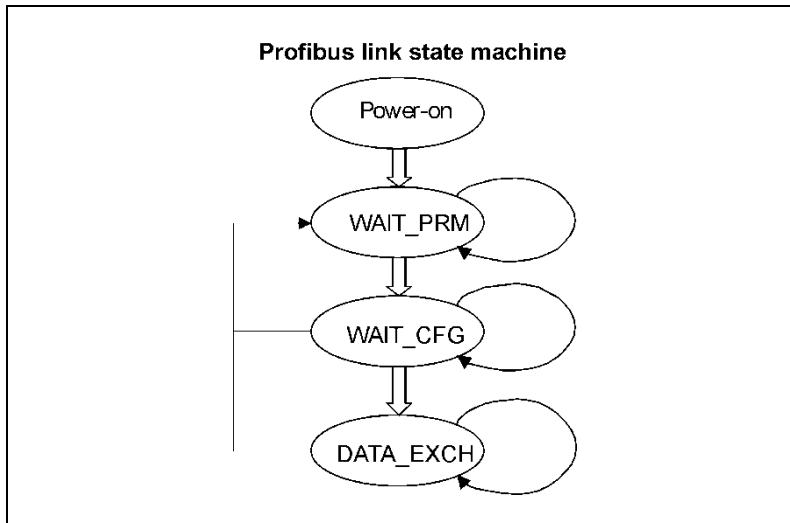

Figure 45

Tab. 17 Profibus state machine

Status	Meaning
POWER_ON	Interface set-up
WAIT_PRM	Wait for parameterisation from the master
WAIT_CFG	Wait for configuration from the master
DATA_EX	Regular data exchange

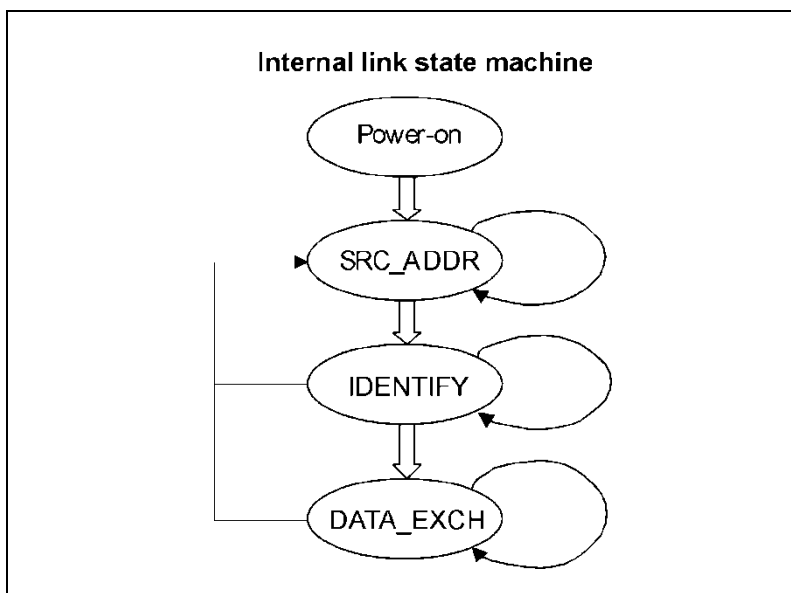

Figure 46

Tab. 18 Internal link state machine

Status	Meaning
POWER_ON	Interface set-up
SRC_ADDR	Search for the controller serial address
IDENTIFY	Identify controller model and protocol
DATA_EX	Regular data exchange

The two machines continuously share I/O data with the relative bus, and interact each other only in following conditions:

- Profibus Data Exchange is suspended (static diagnosis activated) if the internal serial link is not established

- Internal serial link Data Exchange is suspended (only for output data) if the ProfiBus State machine is not in Data Exchange mode

As a general rule, unrecoverable communication errors make each machine to jump to the state immediately following the power-on state (WAIT_PRM or SRC_ADDR).

Message Mapping

The communication is based on the continuous data exchange capability of the ProfiBus standard, where the master sends continuously the entire slave configuration and reads back the entire slave status.

For this purpose one Input (from slave to master) and one Output (from master to slave) buffers are provided. All the needed parameters are mapped inside each buffer.

The following tables summarise the ProfiBus parameter access, related to the corresponding windows serial protocol (for this protocol please refers to the serial interface paragraph).

The interface doesn't any scaling operation on the read/written parameters. It acts only as a gateway between the ProfiBus network and the pump's controller serial interface. As a consequence of this, the scale and the meaning of some parameters depends directly to the specific model of Turbo Pump controller connected to the interface.

Parameter Buffer

Tab. 19 Parameter buffer

OFFSET BYTE	SIZE BYTE	UNIT RES	RANGE	DESCRIPTION	WIN SERIAL
0	1	-	0-99	Gauge gas load type. The value is divided by 10 (entering 12 the controller will apply 1.2) Enter here the correction factor for gas (necessary only if gauge is connected).	161
1	2	mA/Hz/sec	0-10000	Setpoint 1 value. Enter here the threshold value for the R1 output, valid only if B ₀ -B ₂ of Parameter Buffer Offset-21 is equal to 0,1,2 or 3.	102
3	2	Sec	0-30000	Setpoint 1 Mask Time. Set here the time, measured from the start pump event, while the R1 output is masked (not activated)	103
5	2	mA/Hz/sec	0-10000	Setpoint 2 value. Enter here the threshold value for the R2 output, valid only if B ₃ -B ₅ of Parameter Buffer Offset-21 is equal to 0,1,2 or 3.	172
7	2	Sec	0-30000	Setpoint 2 Mask Time. Set here the time, measured from the start pump event, while the R2 output is masked (not activated)	173
9	2	0.2sec/bit	0-30000	Vent Valve Opening Delay. Set the delay time between the stop command and vent opening. Valid only in "purge/vent auto mode" (Parameter Buffer, Offset 20, B ₀ = 0). 0 = infinite (the valve will never open).	126
11	2	0.2sec/bit	0-30000	Vent Valve Open Time. Set how long the vent will remain open, then both purge and vent will be closed. Valid only in "purge/vent auto mode" (Parameter Buffer, Offset 20, B ₀ = 0). 0 = infinite (the valve remain open till next start command).	147
13	1	%	1-99	Setpoint 1 Hysteresis. Set the Setpoint1 hysteresis around the nominal value	105
14	1	%	1-99	Setpoint 2 Hysteresis. Set the Setpoint2 hysteresis around the nominal value	175

17 Technical Information

Profibus Option

15	1	mBar/Torr/P a	0-99	Setpoint 1 Pressure Value Mantissa. Set the mantissa of the exponential value of the R1 setpoint (format X.XE-XX) when it is used for pressure monitoring (Parameter Buffer, Offset 21, B ₀₋₂ = 4). The value set here is divided by 10, that means 11 = 1.1	162
16	1		-10 - +10	Setpoint 1 Pressure Value Exponent. Set the exponent of the exponential value of the R1 setpoint (format X.XE-XX) when it is used for pressure monitoring (Parameter Buffer, Offset 21, B ₀₋₂ = 4).	162
17	1	mBar/Torr/P a	0-99	Setpoint 2 Pressure Value Mantissa. Set the mantissa of the exponential value of the R2 setpoint (format X.XE-XX) when it is used for pressure monitoring (Parameter Buffer, Offset 21, B ₃₋₅ = 4). The value set here is divided by 10, that means 11 = 1.1	176
18	1		-10 - +10	Setpoint 2 Pressure Value Exponent. Set the exponent of the exponential value of the R2 setpoint (format X.XE-XX) when it is used for pressure monitoring (Parameter Buffer, Offset 21, B ₃₋₅ = 4).	176
19	1			B ₀ = Stop Speed Reading. This function measures the pump speed after a stop command. 0 = Off 1 = On	167
				B ₁ = Active Stop. This function brakes the pump after a stop command, by using the motor as a generator. 0 = Off 1 = On	107
				B ₂ - Reserved	
				B ₃₋₄ = Start/Stop/Interlock Mode. Change the logic of Start/Stop and Interlock inputs. Ask to Agilent personnel for this option	151

20	1	<p>B₀ = Vent & Purge Auto/Man 125 0 = Auto (the controller drives purge and vent valves automatically) 1 = Manual (the user can command the valves by serial line or profibus)</p> <hr/> <p>B₁ = Gas Load Type. Select here the gas load 157 0 = Ar 1 = N₂</p> <hr/> <p>B₂ = Interlock Type 110 0 = continuous (the interlock must be always present to run the pump) 1 = at start (the interlock must be present only at start command)</p> <hr/> <p>B₃ = Setpoint R1 Logic 104 0 = active close (NO) 1 = active open (NC)</p> <hr/> <p>B₄ = Setpoint R2 Logic 174 0 = active close (NO) 1 = active open (NC)</p> <hr/> <p>B₅₋₆ = Pressure Unit 163 0 = mbar 1 = Pascal 2 = Torr</p> <hr/> <p>B₇ = Reserved</p>
21	1	<hr/> <p>B₀₋₂ = Setpoint R1 Type 101 0 = frequency 1 = current 2 = time 3 = normal operation 4 = pressure</p> <hr/> <p>B₃₋₅ = Setpoint R2 Type 171 0 = frequency 1 = current 2 = time 3 = normal operation 4 = pressure</p> <hr/> <p>B₆₋₇ = Analog Output 1 Type 111 0 = frequency 1 = power 2 = temperature 3 = pressure</p> <hr/>

Output Buffer

Tab. 20 Output buffer

Offset Byte	Size Byte	Unit Res	Range	Description	WIN Serial
0	1			B ₇ = Start/Stop 0 = Stop, 1 = Start	000
				B ₆ = Low Speed This bit set the pump target speed to "low speed value" (Output Buffer, Offset 3), otherwise the target speed is set to "high speed value" (Output Buffer, Offset 1). 0 = Off, 1 = On	001
				B ₅ – Soft Start This bit activates the soft start function which run-up the pump smoothly. Please activate this function only if the pump has been stopped for at least 3 months. 0 = On, 1 = Off	100
				B ₄ = Vent Valve Command 0 = Close, 1 = Open Valid only if in Par Buff, Offset-20, B ₀ =1	122
				B ₃ = Purge Valve Command 0 = Close, 1 = Open Valid only if Par Buff, Offset-20, B ₀ =1	145
				B ₂ – Not used	
				B _{0,1} = Operating Mode These bits define from which source the controller has to get commands (readings are always available). In order to operate the controller by Profibus these bits must be set to 3. 0 = Remote I/O 1 = Serial 2 = Front panel 3 = Profibus	008
1	2	Hz	1100 - 1350	High Speed Value Set the high rotational speed value	120
3	2	Hz	1100 - 1350	Low Speed Value Set the low rotational speed value	117

Input Buffer

Tab. 21 Input buffer

OFFSET BYTE	SIZE BYTE	UNIT RES	RANGE	DESCRIPTION	WIN SERIAL
0	1	V	0-100	Voltage Voltage provided to the motor	201
1	1	°C	0-100	Pump Bearing Temperature Read the pump upper bearing temperature If > 60 °C the controller goes into fail status and the pump is stopped	204
2	1	°C	0-100	Controller Power Supply Temperature Read the controller power section temperature if > 75 °C the controller goes in fail status "controller over-temperature"	216
3	1	°C	0-100	Controller CPU Section Temperature Read the controller CPU section temperature if > 80 °C the controller goes in fail "controller overtemperature"	211
4	1	-	0-6	B _{0,3} – Status 0 = Stop 1= Waiting for interlock (interlock connections on remote I/O connector missing) 2 = Ramp (the pump is increasing the speed) 3 = Auto tuning (the speed has been reduced because the gas load is higher than the Power Limit Applied) 4 = Braking (the pump is reducing the speed using the motor) 5 = Normal operation (the pump is at target speed) 6 = Fail (see error code byte Input Buffer Byte-27)	205

17 Technical Information
Profibus Option

5	1	-	-	Error Code (bit field)	206
				B ₇ – Too High Load (the gas load is too high for the pump)	
				B ₆ – Short Circuit (a short circuit happened between the two of the three motor phases)	
				B ₅ – Over Voltage (too high bus voltage during braking)	
				B ₄ – Verify Line Select Not used	
				B ₃ – Power Fail (internal circuitry failure)	
				B ₂ – Controller Over-Temperature (“Controller Power Section Temperature” or “Controller CPU Section Temperature” are over the limit)	
				B ₁ - Pump Over-Temperature (“Pump Bearing Temperature” or “Pump Body Temperature” are over the limit)	
				B ₀ – Check Connection To Pump (the connection between controller and pump missing)	
6	1	-	-	B ₀ – Set Point R1 Status 0 = open 1 = closed	221
				B ₁ – Set Point R2 Status 0 = open 1 = closed	225
				B ₂ – Vent Valve Status 0 = closed 1 = open	122
				B ₄ – Not Used	
				B ₅ – Not Used	
				B ₆ – Not Used	
				B ₇ – Not Used	

7	2	mA	0-10000	Current Motor current consumption	200
9	2	W	0-200	Power Motor power adsorption	202
11	2	W	0-200	Power Limit Applied Maximum allowable power	155
13	2	Hz	0-1500	Driving Frequency Read the rotational speed of the pump	203
15	2	Hz	0-1500	Target Frequency Read the target rotational speed	120
17	2	-	0-65536	Cycle Number Number of cycles (start and stop) done by the pump	301
19	2	min	0-65536	Last Cycle Time How long the last cycle lasted	300
21	2	h	0-65536	Pump Life Total pump running time	302
23	4	mBar/Torr/ Pa	-	Pressure Reading Reports the pressure reading in the "pressure unit" selected by Par. Buff., Offset-20, B _{5.6}	224

Diagnostic Management

In addition to the ProfiBus six byte standard diagnostic, the interface provides both user diagnostic and static diagnostics functions

The standard diagnostic management is fully compliant with the ProfiBus specification.

During the start-up phase after power on, the first byte in the user diagnostic area, can assume values different from zero.

This byte has the following meaning:

- Bit 0 = 1: controller not responds (RS-485 link broken)
- Bit 1 = 1: controller not identified (not compatible with the ProfiBus gateway)
- Bit 2 = 1: first loop of requests not ended (values in the input data are not fully coherent yet)

So, if the first byte is equal to 0, the interface is working properly, otherwise there is a problem.

Each nibble in the bytes following the interface status byte represents the status of the last attempt to write a parameter with following coding (diag status byte):

- | | |
|---|---|
| 0 | Write success |
| 1 | Controller response was “NACK” |
| 2 | Controller response was “Unknown window” |
| 3 | Controller response was “Bad Data Type” |
| 4 | Controller response was “Over range” |
| 5 | Controller response was “Bad operation” |
| 6 | Controller response was an unknown response |
| F | Parameter not supported by the controller |

The ProfiBus external diagnosis services are used to report following unexpected situations:

- **Controller fail:** if the controller goes in fail mode, an external diagnostic service is required and one byte in the diagnostic buffer signals the type of failure.
- **User parameter mismatch:** if the user sets one or more parameters out of their allowed range, a ProfiBus external diagnostic service is required and some bits in the diagnosis frame signals which parameter is wrong (i.e. over range or under range).

Diagnostic Buffer

Tab. 22 Diagnostic buffer

OFF SET	MEANING		
0	B ₀	station non exist (set by master)	Standard diagnostic
	B ₁	station not ready (slave not ready for data exchange)	
	B ₂	cfg fault (configuration data doesn't match)	
	B ₃	ext diag (slave has external diagnostic data)	
	B ₄	not supported (slave doesn't support requested function)	
	B ₅	invalid slave response (slave sets permanent '0')	
	B ₆	prm fault (wrong parameter assignment)	
	B ₇	master_lock (slave is parameterised by another master)	
1	B ₀	prm req (slave has to be re-parameterised)	
	B ₁	stat diag (static diagnosis)	
	B ₂	fixed '1'	
	B ₃	wd_on (response monitoring active)	
	B ₄	Freeze mode (received freeze command)	
	B ₅	Synch mode (received synch command)	
	B ₆	reserved	
	B ₇	diag deactivated (slave is parameterised by another master)	
2	Reserved		
3	Master Add (master address after parameterisation. FF= without parameter)		
4	Ident number high		
5	Ident number low		
6	External diagnosis "Header" length indication including header		

OFF SET	MEANING		
7	Interface Status	External diagnostic	
	B ₀ Controller not responds		
	B ₁ Controller not identified		
	B ₂ Input data not fully coherent yet		
	B ₃ Not used		
B ₄₋₇ Not used			
8	B _{7.4} – Start/Stop diag status	External diagnostic	
	B _{3.0} – Low Speed diag status		
9	B _{7.4} – Soft Start diag status		External diagnostic
	B _{3.0} – Vent Valve		
10	B _{7.4} – Not used		
	B _{3.0} – Mode		
11	B _{7.4} – High speed	External diagnostic	
	B _{3.0} – Low Speed		

Error Messages

For a certain type of failure, the controller will self-diagnose the error and the following messages will be displayed.

NOTE

If the pump is not connected, the display will be as shown in the following figure.

C	H	E	C	K		C	O	N	N	E	C	T	I	O	N
			T	O		P	U	M	P						

Check connection between controller and pump, then press STOP push-button twice to start the pump.

NOTE

If the P1 input connector is not in position with the link or the external interlock connections are open, when the START pushbutton is pressed the display will be as shown in the following figure.

					W	A	I	T	I	N	G				
				I	N	T	E	R	L	O	C	K			

Disconnect connector P1 and check the link or the external interlock, then install the connector to start the pump.

NOTE

If within each step of the soft start mode the rotational speed of the pump do not reach the planned value within 15 minutes the display will be as shown in the following figure.

	T	O	O		H	I	G	H		L	O	A	D	

Verify that systems has no leaks than press STOP RESET pushbutton twice to start the pump.

Check that pump rotor is free to rotate then press the STOP RESET pushbutton twice to start the pump.

NOTE

If in normal operation (after the starting phase) the current drawn by the pump is higher than programmed (1.8 A), the pump and the interconnected devices are switched off and the display will be as shown in the following figure.

	T	O	O		H	I	G	H		L	O	A	D	

Verify that systems has no leaks than press STOP RESET pushbutton twice to start the pump.

Check that pump rotor is free to rotate then press the STOP RESET pushbutton twice to start the pump.

NOTE

If the upper bearing/pump temperature exceeds 60°C, the pump is shut off, and the display will be as shown in the following figure.

						P	U	M	P					
				O	V	E	R	T	E	M	P			

The message will stay on until the temperature decreases below threshold value. Press the STOP RESET pushbutton twice to start the pump.

17 Technical Information

Error Messages

NOTE

If the controller transformer temperature exceeds 90°C, the pump is shut off, and the display will be as shown in the following figure.

			C	O	N	T	R	O	L	L	E	R			
			O	V	E	R	T	E	M	P					

The message will stay on until the temperature decreases below threshold value. Press the STOP RESET pushbutton twice to start the pump.

			P	O	W	E	R		F	A	I	L			

Indicates a fault in the circuit of the controller used to power the pump.

NOTE

If the pump is stopped by an emergency stop signal provided via a remote contact, the display will be as shown in the following figure.

				S	Y	S	T	E	M						
			O	V	E	R	R	I	D	E					

Remove the controller power cable and check the emergency condition.

Then reconnect the power cable and press the START pushbutton to start the pump.

		O	V	E	R	V	O	L	T	A	G	E			

Controller power supply circuitry is faulty, or the Controller received a spike.

Press the **START** push-button twice to start the pump. Should the message still be present, call the Agilent service.

	S	H	O	R	T		C	I	R	C	U	I	T		

Check connections and shortages between pump and controller, then press the **STOP RESET** pushbutton twice to start the pump.

Orderable Parts

Tab. 23

Description	Part number
TwisTorr 84 FS AG Rack Controller with RS-232/485	X3508-64001
84 FS AG Rack Controller with Profibus option	X3506-64002
Air cooling kit (0.5 m)	9699290
Air cooling kit Extension cable (5 m)	9699940
Vent Valve N.O. 0,5 mm orifice (0,5 m cable)	9699844
Vent Valve extention cable (5 m)	9699941
Mains cable NEMA plug (3 m)	9699958
Mains cable european plug (3 m)	9699957
FRG 700/702	"see catalog"
IMG 500	"see catalog"
PVG 500/502	"see catalog"
IM 500	"see catalog"
CDG 500 T1000	"see catalog"
CDG 500 T0100	"see catalog"
CDG 500 T0010	"see catalog"
CDG 500 T0001	"see catalog"



Vacuum Products Division

Dear Customer,

Thank you for purchasing an Agilent vacuum product. At Agilent Vacuum Products Division we make every effort to ensure that you will be satisfied with the product and/or service you have purchased.

As part of our Continuous Improvement effort, we ask that you report to us any problem you may have had with the purchase or operation of our products. On the back side you find a Corrective Action request form that you may fill out in the first part and return to us.

This form is intended to supplement normal lines of communications and to resolve problems that existing systems are not addressing in an adequate or timely manner.

Upon receipt of your Corrective Action Request we will determine the Root Cause of the problem and take the necessary actions to eliminate it. You will be contacted by one of our employees who will review the problem with you and update you, with the second part of the same form, on our actions.

Your business is very important to us. Please, take the time and let us know how we can improve.

Sincerely,

A handwritten signature in black ink, appearing to read "Giampaolo LEVI".

Giampaolo LEVI

*Vice President and General Manager
Agilent Vacuum Products Division*

Note: Fax or mail the Customer Request for Action (see backside page) to Agilent Vacuum Products Division (Torino) – Quality Assurance or to your nearest Agilent representative for onward transmission to the same address.

Vacuum Products Division Instructions for returning products

Dear Customer,

Please follow these instructions whenever one of our products needs to be returned.

Complete the attached **Request for Return form** and send it to Agilent Technologies (see below), taking particular care to include the completed **Health and Safety** declaration Section. No work can be started on your unit until we receive a completed copy of this form.

After evaluating the information, Agilent Technologies will provide you with a **Return Authorization (RA) number** via email or fax, as requested. Note: Depending on the type of return, a Purchase Order may be required at the time **the Request for Return is submitted**. We will quote any necessary services (evaluation, repair, special cleaning, eg).

Product preparation

- Remove all accessories from the core product (e.g. inlet screens, vent valves).
- Prior to shipment and if applicable for your product, drain any oils or other liquids, purge or flush all gasses, and wipe off any excess residue.
- If ordering an Advance Exchange product, please use the packaging from the Advance Exchange to return the defective product.
- Seal the product in a plastic bag, and package product carefully to avoid damage in transit. You are responsible for loss or damage in transit.
- Include a copy of the Health and Safety Declaration in the shipping documentation on the outside of the shipping box of your returning product.
- Clearly label package with RA number. Using the shipping label provided will ensure the proper address and RA number are on the package. Packages shipped to Agilent without a RA clearly written on the outside cannot be accepted and will be returned.
- Return only products for which the RA was issued.

Shipping

- Ship to the location specified on the printable label, which will be sent, along with the RA number, as soon as we have received all of the required information. Customer is responsible for freight charges on returning product.
- Return shipments must comply with all applicable Shipping Regulations (IATA, DOT, ADR, etc.) and carrier requirements.

RETURN THE COMPLETED **REQUEST FOR RETURN** FORM TO YOUR NEAREST LOCATION:

EUROPE:

Fax: 00 39 011 9979 330
Fax Free: 00 800 345 345 00
Toll Free: 00 800 234 234 00

NORTH AMERICA:

Fax: 1 781 860 9252
Toll Free: 800 882 7426, Option 3

PACIFIC RIM:

Please visit our website for individual office information

vpt-customer@agilent.com

vpl-ra@agilent.com

<http://www.agilent.com>



TERMS AND CONDITIONS

Please read the terms and conditions below as they apply to all returns and are in addition to the Agilent Technologies Vacuum Product Division – Products and Services Terms of Sale.

- Unless otherwise pre-negotiated, customer is responsible for the freight charges for the returning product. Return shipments must comply with all applicable **Shipping Regulations** (IATA, DOT, etc.) and carrier requirements.
- Agilent Technologies is not responsible for returning customer provided packaging or containers.
- Customers receiving an Advance Exchange product agree to return the defective, rebuildable part to Agilent Technologies **within 15 business days**. Failure to do so, or returning a non-rebuildable part (crashed), will result in an invoice for the non-returned/non-rebuildable part.
- Returns for credit toward the purchase of new or refurbished Products are subject to prior Agilent approval and may incur a restocking fee. Please reference the original purchase order number.
- Units returned for evaluation will be evaluated, and a quote for repair will be issued. If you choose to have the unit repaired, the cost of the evaluation will be deducted from the final repair pricing. A Purchase Order for the final repair price should be issued within 3 weeks of quotation date. Units without a Purchase Order for repair will be returned to the customer, and the evaluation fee will be invoiced.
- Products returned that have not been drained from oil will be disposed.
- A Special Cleaning fee will apply to all exposed products.
- If requesting a calibration service, units must be functionally capable of being calibrated.



Customer information		
Company :	Contact Name:	
Address:	Tel:	Fax:
	Email:	

Equipment			
Product description	Agilent PartNo	Agilent Serial No	Original Purchasing Reference
Failure description		Type of process (for which the equipment was used)	

Type of return	
<input type="checkbox"/> Non Billable <input type="checkbox"/> Billable ➔ New PO # (hard copy must be submitted with this form): _____ <input type="checkbox"/> Exchange <input type="checkbox"/> Repair <input type="checkbox"/> Upgrade <input type="checkbox"/> Demo <input type="checkbox"/> Calibration <input type="checkbox"/> Evaluation <input type="checkbox"/> Return for Credit	

Health and safety The product has been exposed to the following substances: (by selecting 'YES' you MUST complete the table to the right)	Substances (please refer to MSDS forms) <small>* Agilent will not accept delivery of any product that is exposed to radioactive, biological, explosive substances or dioxins, PCB's without written evidence of decontamination.</small>			
	Trade name	Chemical name	Chemical Symbol	CAS Number
Toxic	<input type="checkbox"/> YES <input type="checkbox"/> NO			
Harmful	<input type="checkbox"/> YES <input type="checkbox"/> NO			
Corrosive	<input type="checkbox"/> YES <input type="checkbox"/> NO			
Reactive	<input type="checkbox"/> YES <input type="checkbox"/> NO			
Flammable	<input type="checkbox"/> YES <input type="checkbox"/> NO			
Explosive (*)	<input type="checkbox"/> YES <input type="checkbox"/> NO			
Radioactive (*)	<input type="checkbox"/> YES <input type="checkbox"/> NO			
Biological (*)	<input type="checkbox"/> YES <input type="checkbox"/> NO			
Oxidizing	<input type="checkbox"/> YES <input type="checkbox"/> NO			
Sensitizer	<input type="checkbox"/> YES <input type="checkbox"/> NO			
Other dangerous substances	<input type="checkbox"/> YES <input type="checkbox"/> NO			

Goods preparation	
If you have replied YES to one of the above questions. Has the product been purged?	<input type="checkbox"/> YES <input type="checkbox"/> NO
If yes, which cleaning agent/method:	
Has the product been drained from oil?	<input type="checkbox"/> YES <input type="checkbox"/> NOT APPLICABLE
I confirm to place this declaration on the outside of the shipping box.	<input type="checkbox"/>

I declare that the above information is true and complete to the best of my knowledge and belief. I understand and agree to the terms and conditions on page 2 of this document.	
Name:	Authorized Signature:
Position:	
Date:	

NOTE: If a product is received at Agilent which is contaminated with a toxic or hazardous material that was not disclosed, the customer will be held responsible for all costs incurred to ensure the safe handling of the product, and is liable for any harm or injury to Agilent employees as well as to any third party occurring as a result of exposure to toxic or hazardous materials present in the product.

Agilent Vacuum Products Division/Sales and Service Offices

United States

Agilent Technologies

121 Hartwell Avenue
Lexington, MA 02421 - USA
Ph. +1 781 861 7200
Fax: +1 781 860 5437
Toll-Free: +1 800 882 7426
vpl-customer@agilent.com

Netherlands

Agilent Technologies Netherlands B.V.

Customer Contact Center
Laan van Langerhuize 1, toren A-8
1186 DS Amstelveen
Tel. +31 020 547 2600
Fax +31 020 654 5748
customer@agilent.com

Belgium

Agilent Technologies Belgium S.A./N.V.

Customer Contact Center
Pegasus Park
De Kleetlaan 12A bus 12
B-1831 Diegem
Tel. +32 2 404 92 22
Fax +32 2 626 46 30
customer@agilent.com

Brazil

Agilent Technologies Brasil

Avenida Marcos Penteado de Ulhoa
Rodrigues, 939 - 6° andar
Castelo Branco Office Park
Torre Jacarandá - Tamboré
Barueri, Sao Paulo CEP: 06460-040
Toll free: 0800 728 1405

China

Agilent Technologies (China) Co. Ltd

No.3, Wang Jing Bei Lu, Chao Yang District
Beijing, 100102, China
Tel: +86 (0)10 64397888
Fax: +86 (0)10 64392765
Toll free: 400 8206778 (mobile)
Toll free: 800 8206778 (landline)
vacuum.cnmarketing@agilent.com
vpc-customerservice@agilent.com

France

Agilent Technologies
Parc Technopolis - Z.A. de Courtaboeuf
3, avenue du Canada - CS 90263
91978 Les Ulis cedex, France
Tel: +33 (0) 1 64 53 61 15
Fax: +33 (0) 1 64 53 50 01
vpf.sales@agilent.com

Southeast Asia

Agilent Technologies Sales Sdn Bhd

Unit 201, Level 2 uptown 2,
2 Jalan SS21/37, Damansara Uptown
47400 Petaling Jaya, Selangor, Malaysia
Ph. +603 7712 6181
Fax: +603 7727 1239
Toll free: 1 800 880 805
vps-customerservice@agilent.com

India (Sales)

Agilent Technologies India Pvt. Ltd.

Unit Nos 110- 116, & Part of 101 & 109
First Floor, Splendor Forum,
Plot No.-3, District Centre, Jasola
New Delhi-110025
Ph. +91 11 4623 7100
Fax: +91 4623 7105
Toll Free: 1 800 180 1517

Italy

Agilent Technologies Italia S.p.A.

Via F.Ili Varian, 54
10040 Leini, (Torino) - Italy
Tel: +39 011 9979 111
Fax: +39 011 9979 350
Toll free: 00 800 234 234 00
vpt-customerservice@agilent.com

Japan

Agilent Technologies Japan, Ltd.

9-1 Takakura-cho Hachioji-city,
Tokyo, Japan
Tel.: +81- 3-5232-1253
Fax: +81-120-565-154
Toll-Free: +81-120-477-111
jp-vvt-sales.pdl-ext@agilent.com

Singapore

Agilent Technologies Singapore Pte. Ltd.

1 Yishun Avenue 7,
Singapore 768923
Tel : (65) 6215 8045
Fax : (65) 6754 0574
Toll free: 1 800 2762622
vps-customerservice@agilent.com

Korea

Agilent Technologies Korea, Ltd.

Ilshin Building 4F
Yongsan-gu Hannam-daero
Seoul Korea 04418
Tel: +82 (0)2 2194 9449
Fax: +82 (0)2 2194 9853
Toll free: 080 222 2452
vpc-customerservice@agilent.com

UK and Ireland

Agilent Technologies LDA UK Limited

Lakeside Cheadle Royal Business Park
Cheadle, Cheshire SK8 3GR,
United Kingdom
Ph. +44 01865291570
Fax +44 01865291571
Toll free: 00 800 234 234 00
Toll free fax: 00 800 345 345 00
vpt-customer@agilent.com

© Agilent Technologies, Inc. 2018
07/2018

India (Service)

Agilent Technologies India Pvt. Ltd.
C-Block, RMZ Centennial Plot Number- 8A, 8B, 8C,
8D,
Doddanakundi Industrial Area, ITPL Road,
Mahadevapura Post, Bangalore- 560048
Ph. +91 80 40614000
Fax: +91 80 40148991

Taiwan

Agilent Technologies Taiwan Limited

No. 20 Gao-shuang Road, Ping-zhen Dist
Tao-Yuan City
32450 Taiwan, R.O.C.
Tel: +886 3 4959004
Toll free: 0800 018 768
vpw-customerservice@agilent.com

Germany and Austria

Agilent Technologies Sales & Services GmbH & Co. KG

Lyoner Str. 20
60 528 Frankfurt am Main
GERMANY
Tel: +49 69 6773 43 2230
Fax: +49 69 6773 43 2250

Mexico

Agilent Technologies

Concepcion Beistegui No 109
Col Del Valle
C.P. 03100 – Mexico, D.F.
Tel.: +52 5 523 9465
Fax: +52 5 523 9472

Other Countries

Agilent Technologies Italia S.p.A.

Via F.Ili Varian, 54
10040 Leini, (Torino) - Italy
Tel.: +39 011 997 9111
Fax: +39 011 997 9350
Toll-Free: 00 800 234 234 00
vpt-customer@agilent.com

Customer Support & Service

NORTH AMERICA:

Toll Free: 800 882 7426
vpl-ra@agilent.com
Lexington-service@agilent.com

EUROPE:

Toll Free: 00 800 234 234 00
vpt-customer@agilent.com

PACIFIC RIM:

please visit our website for individual office
information
<http://www.agilent.com/chem/vacuum>

Worldwide Web Site, Catalog and Order On-line:

www.agilent.com/chem/vacuum
Representatives in most countries