

# BESELER PHOTOGRAPHIC EQUIPMENT

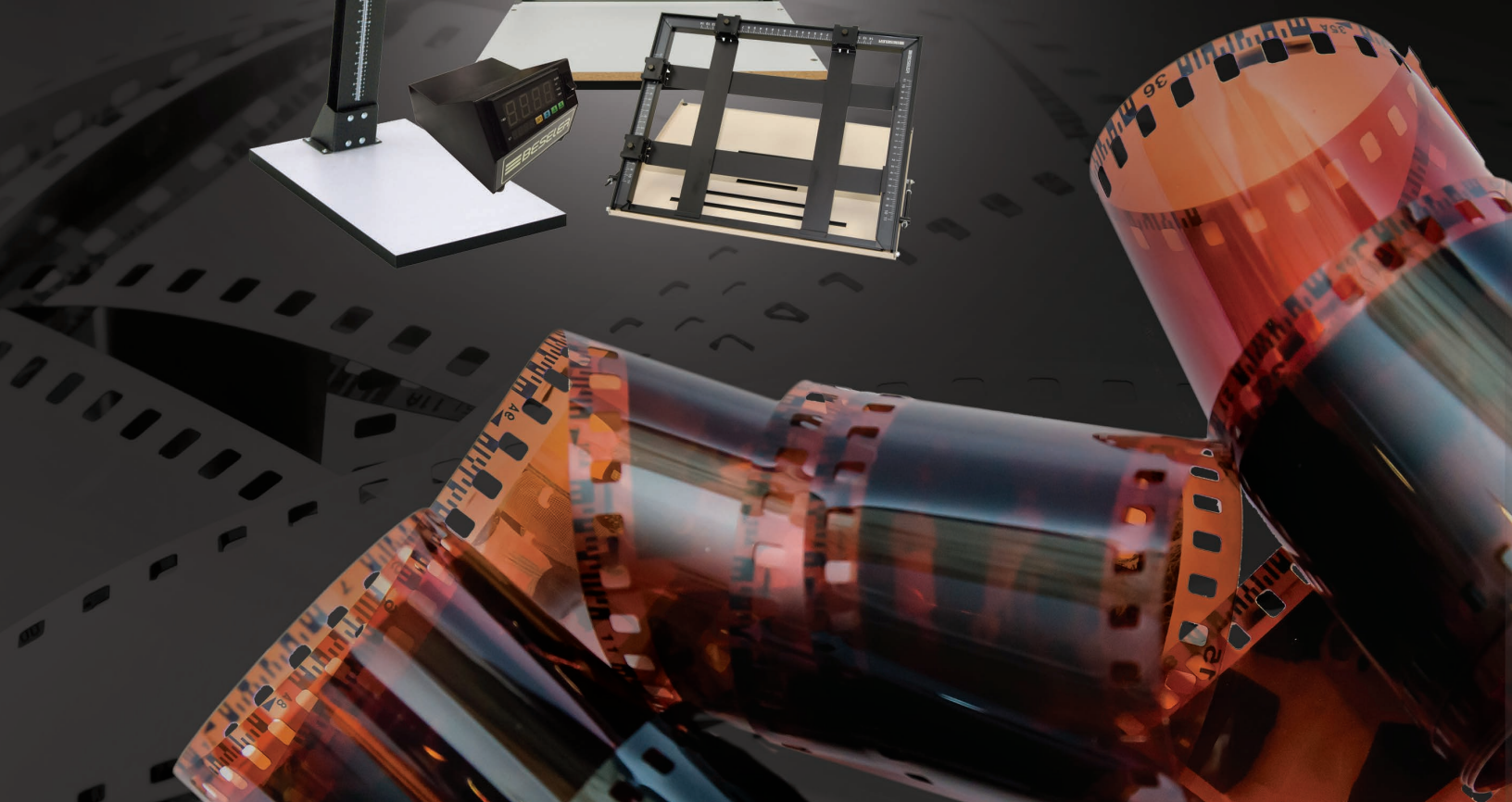

*Developing excellence for over 65 years*







## 150 Years of Manufacturing Excellence

The Charles Beseler Company was founded in 1869 as a manufacturer of a variety of products including inhalers, magic lanterns with oil lamps and stereopticons. By 1943 the company had become an innovative audio-visual company serving the military and education markets. In 1953, Beseler entered the amateur and professional photography fields with the development of the 45 Series Enlarger and other darkroom products.

Today, the Charles Beseler Company continues to be the leading supplier of photographic darkroom equipment for the educational market. Proudly made in the USA, at a modern manufacturing facility in Stroudsburg, Pennsylvania, Beseler's line of high-quality photographic equipment continues to withstand the test of time and remains the industry standard for professionals and amateurs alike.

[beseler.com](http://beseler.com)



## NEW PRODUCT DESIGN AND INNOVATION. A BESELER TRADITION.

Our team of experts is constantly working on engineering and manufacturing new products to meet your most challenging photographic needs. Check back on our website to discover the very latest Beseler products, parts and accessories in the coming months!



From enlargers and light sources to copy stands and easels, Beseler offers the highest quality photographic equipment, all backed by an experienced sales and service team. See why photographers have trusted our products for generations.

**ENLARGERS** 2-3

**LIGHT SOURCES** 4-5

**EASELS** 6

**COPY STANDS** 7

**ACCESSORIES AND REPLACEMENT PARTS** 8-9



# ENLARGERS



## 23C III-XL Enlargers

All 23C III-XL enlargers are built around the extra long and rigid twin girder construction which helps reduce vibrations while allowing print sizes larger than 16" x20" on the baseboard. A rack and pinion carriage elevation system provides exceptionally smooth magnification adjustments while the positive locking mechanism assures that magnification settings do not shift during the focus exposure. The modular design includes a number of system features. These features include more precise alignment of the negative and lens stages for greater optical performance, a tilting projection assembly for wall projections, a distortion correcting lens stage, a below the lens filter holder which accommodates variable contrast or special filters, and a smooth friction drive focus assembly which allows for left or right handed control.

All 23C III-XL lamp houses accept formats up to and including 6x9cm and have ample space on the sturdy 16" x25½" white laminated baseboard.

### 23C Accessories

8016	Lensboard 4x4 .25" Hole	8053	Neg Carrier 23C 35MM Film	8072	Neg Carrier 23C W/Anti Newton Glass
8021	Lensboard 4x4 .Pilot Light	8054	Neg Carrier 23C 2" SQ Slide	8074	Neg Carrier 23C Universal Glass
8022	Lensboard 4x4 .Recessed	8055	Neg Carrier 23C 35MM Full Frame	8086	Lensboard Mounted 39MM Flange
8023	Lensboard 4x4 .Pilot Light	8060	Neg Carrier 23C 6X6CM Roll Film	8101	Lamp, Enlarger 120V 75W
8029	Lensboard 4x4 .Pilot Light	8062	Neg Carrier 23C 6X9CM Roll Film	8104	Lamp, Enlarger 120V 75W
8042	Filter Heat Absorbing 23C	8070	Neg Carrier 23C 6X7 Roll Film	8108	Lamp, Projector 82V 250W
8048	Neg Carrier 23C 645 Roll Film	8066	Neg Carrier 23C 35MM A/N Glass	8139	Alignment Tool

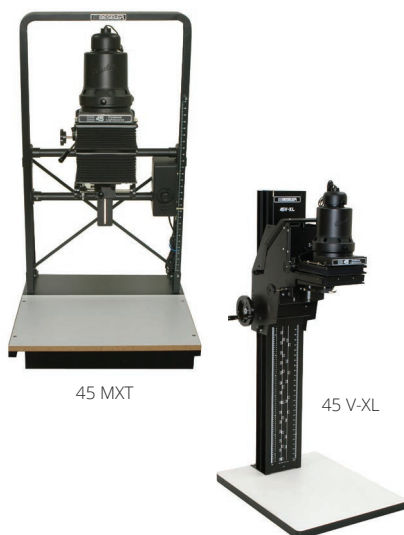

45 MXT

45 V-XL

## 45 MXT Enlarger

The 45 MXT motorized chassis provides a sturdy foundation for this enlarging system. The enlarger chassis has a triangular reinforced truss with twin girder frame which permits the enlarger to produce prints greater than 16" x20" on the baseboard from 35mm film.

## 45 V-XL The Professional's Enlarger

The 45 V-XL sets the standard for professional laboratory use offering faster operation, greater productivity, increased efficiency, and unprecedented versatility in a large format enlarger. Its massive twin E-Channel with center-braced and vertical column assures that the center of the projected image remains stationary when changing image magnification. Thus, there is no need to reposition the enlarging easel, especially important with roll easel users. The extra long column permits enlargements greater than 24x on the baseboard from 35mm film with a 50mm lens.

The 45V-XL accepts the Beseler 3 lens turret, all the 45 series light sources and lensboards, and film carriers.

### 45/810 Accessories

8128	MXT Wall Projection Bracket	8302	Neg Carrier 4X5 35MM Full Frame	8342	Neg Carrier 4X5 Glass
8225	Turret Lens	8304	Neg Carrier 4X5 35MM Film	8343	Neg Carrier 4X5 Glass Anti-Newton
8239	Mount Wall 45MX	8305	Neg Carrier 4X5 35MM Slide 2" SQ	8370	Lens Adaptor 39MM X 6.5MM FEM Thread
8540	Table Enlarger Adjustable 4X5	8312	Neg Carrier 4X5 6X6CM Roll Film	8371	Lens Adaptor 39MM X 11.5MM FEM Thread
8562	Mount Wall 45V-XL	8314	Neg Carrier 4X5 6X9CM Roll Film	8373	Lens Adaptor 50MMX.75MM 21MM L
8037	Lensboard 4X4 Pilot Light	8322	Neg Carrier 4X5 4X5 Cut Film	8390	Neg Carrier 4X5 Polaroid Film
8077	Filter Heat Absorbing 45M	8328	Neg Carrier 4X5 120 Mamiya	8391	Neg Carrier 4X5 35MM Panoramic
8088	Lensboard 4X4 150MM SCH APO	8334	Neg Carrier 4X5 Mamiya M645		



## 67 XLC Condenser, 67 XLD Dichro Color and 67 XLVC Enlarger

The enlarger's single column emulates the braced, twin channel design found in Beseler's "top of the line" 45 VXL and assures solid support at the highest magnifications. The column allows prints as large as 16" x20" to be made on the baseboard from 35mm negatives and a 50mm lens. A built in swivel allows the projection assembly to rotate making wall projection easy.

Additional features include an improved rack and pinion elevation control with locking mechanisms, right and left hand focusing controls, elevation reference scale and below the lens filter holder.

These enlargers are a fine example of the extra measure of craftsmanship and performance which have characterized Beseler products for over 140 years.

All 23C III-XL lamp houses accept formats up to and including 6x9cm and have ample space on the sturdy 16" x 25½" white laminated baseboard.



## Printmaker 35/67 Condenser, Printmaker Dichro 67 and 67 Variable Contrast Enlargers

The Printmaker 35 is an excellent choice for those who are using the 35mm format while the 67 is equipped to handle from 35mm up to 6x7 cm formats. The Printmaker now performs better than ever. The Printmaker's compact size makes it perfect for small darkrooms, temporary darkrooms, or portable darkrooms. It can produce prints up to 11" x14" on the baseboard or much larger when reversing the column and projecting on the floor. Additional features include a focus knob, which can be attached for either left or right handed use, a built in elevation scale, and a below the lens filter holder.

### Printmaker and 67 Accessories

6723	Lensboard 67C 39MM Thread	6741	Neg Carrier 67C 6x6CM Roll Film	8047	Dust Cover 23C/67CS Enlarger
6728	Lamp, Colored Dichro 67S	6742	Neg Carrier 67C 6x7CM Roll Film	8092	Adaptor Negatrans for 645 Film
6737	Neg Carrier 67C 35MM Roll Film	6746	Neg Carrier 67C 2x2 MTD Slide	8204	Remote Shaft Kit
6738	Neg Carrier 67C 35MM Full Frame	6760	Filter Heat Absorber	6727	Mixing Chamber 6x7
6740	Neg Carrier 67C Mamiya M645	8040	Filter Red Safety 2.375" SQ		



## Cadet®II Enlarger

The Cadet®II is ideally suited for both beginners and experienced amateur 35mm photographers. It's compact, lightweight design, plus ease of assembly, setup, and storage offers the perfect solution for the temporary or traveling darkroom. The Cadet®II comes equipped and ready for use, complete with a 35mm negative/slide carrier, a filter drawer for 3" x3" color or variable contrast printing filters, 2¼" optional glass condenser, a 1¼"x1 1¾" white laminated baseboard for enlargements up to 8" x10" and our new four element 50mm lens. The reversible column allows for floor projection and larger magnifications. The column features a counter-balanced elevation control as well as an elevation scale for speedy printing size.

# LIGHT SOURCES



## LED Dichro 45SL

Beseler has stayed true to its traditional design yet adds modern day technology to introduce our new and improved Dichro 45SL Colorhead. This head fits directly onto our 45MXT & 45VXL series enlargers & uses new LED technology to provide a diffusion light source that is reliable and dependable lasting throughout years of darkroom use. The LED lighting has eliminated the need for an internal cooling fan, keeping the unit steady during exposure times. An external stabilized power supply allows change from color to black & white printing with the flick of a switch. Filtration values are individually displayed on an illuminated analog scale with controllable dimmer switch located on the power supply. Filtration values range from 0-200cc of Yellow, Magenta and Cyan.



## 23C-III Condenser Lamphouse

Black & white printing is in focus with this mainstay of our 23C enlarger series. Accommodating any negative size up to 2 1/4" x 3 1/4" (6 x 9cm), this popular head has withstood the test of time and comes standard with our 23CIII condenser enlarger, catalog # 8004-02. Includes two custom glass condenser lenses.



## 23C-III Dichro Colorhead

23C-III Dichro Colorhead features 0-200cc of continuously variable, fade free, dichroic filters for Yellow, Magenta, and Cyan. Comes with a built in power supply and 6 x 9cm mixing chamber.



## 23C-III Variable Contrast Lamphouse

67VC Variable Contrast lightsource for use with all printmakers and 67 series enlargers. The diffusion type with additive color lightsource allows for continuous contrast changes from grade 0-5 for most variable contrast papers. Available in colors Black, Green, Yellow, and Red.



## 45 M Condenser Lightsource

Includes two over sized 6½" optical glass condensers which work with the Beseler "Cone-of-Light" principle to maximize illumination on any film format up to 4" x 5". Contains a filter drawer for 6½" x 6½" filters and high output lamp. The lightsource fits all Beseler 4" x 5" enlargers.



## 67 S Dichro Colorhead

67 S Dichro Colorhead filled with features such as continuously variable 0-200cc dial in filtration, white light filter retractor lever, integral solid state power supply, and interchangeable mixing chamber are included to provide optimum illumination for formats from 8mm through 6" x 7". The lightsource is ready to be mounted on Printmaker 35 and all other 6" x 7" series enlargers.



## 67VC Variable Contrast Lightsource

67VC Variable Contrast lightsource for use with all printmakers and 67 series enlargers. The diffusion type with additive color lightsource allows for continuous contrast changes from grade 0-5 for most variable contrast papers. Available in colors Black, Green, Yellow, and Red.



# EASELS



## Universal 4 – Bladed Easel

All metal 4-bladed enlarging easels that features heavy gauge spring steel blades. Precision design rails made from aluminum extrusion ensure accuracy. Masking blades are detachable for individual arrangement. The unique finish makes it easy to compose the image before inserting paper. Also, includes "O" center measuring scale for both axes, free moving blade carriage with securing lock, dual spring-loaded hinge, and unique white viewing strips which aid in cropping and composition.

Available in 11" x 14", 16" x 20", 20" x 24"

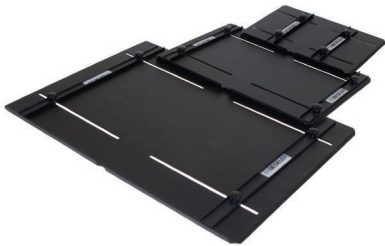

## Borderless Enlarging Easels

Designed with special "finger lift" notches for removing paper, these easels feature two adjustable paper guides with locking knobs. The non-reflective high tech black epoxy finish is as functional as it is aesthetic.

Available in 8" x 10", 11" x 14", 16" x 20"



# COPY STANDS



## Photography Copy Stands

All models feature a uniquely adjustable camera platform which facilitates the precise alignment of the optical axis of the camera over the exact center of the baseboard. Copy positioning on the 18% grey baseboard is aided by an abundance of baseboard positioning grids, format patterns, and reference scales. Magnetic hold down bars locate the copy and keep it flat in place.



### CS-14

The camera platform moves on a single-straight vertical column, aided by a constant force, counter-balanced elevation system. At the desired elevation, the turn of a knob locks the camera securely in position. The column is anchored to the 16" x 19" baseboard at four points and is suitable for cameras weighing up to five pounds. The maximum recommended copy size is 14" x 14".



### CS Digital/Photo-Video

The Copystand emulates the rigid twin E-Channel center braced column so popular in the 45 V-XL enlarger chassis. A rack and pinion elevation system positions your still digital or video camera where it can be easily locked into position. The 44" column is securely mounted to a 22" x 22" baseboard and is suitable for camera weighing up to 16 pounds. The maximum recommended copy size is 20" x 20".

## Copystand Accessories

4212 Copy Light Arms CLA-20/21

4230-01 Copy Light 120V Single

4235-01 Reflector 4235 5" Single Pack

# ACCESSORIES AND REPLACEMENT PARTS



## Lenses

These quality lenses designed exclusively by Beseler contain an additional lens element for exceptional sharpness and clarity. The improved lens design offers professional grade features, yet maintains an affordable price for educational or entry level programs. The new 50mm lens is now standard with our Cadet II® enlarger series. Both lenses come complete with jam nut/retaining ring.

Features:

- 4 coated glass lens elements (previously 3) for added sharpness and clarity
- Defined click stops for easier use in the darkroom
- Increased aperture range f/3.5 to new f/22 (previously f/16)
- 39mm Leica mount for compatibility with existing accessories

## Lens Kit

Includes 50mm Lens, Lensboard, Negative Carrier & Jam Nut.

6770	50mm Lens Kit for Printmaker & 67 series Enlargers
6777	50mm Lens Kit for Printmaker & 67 Series Enlarger, Full Frame
9170	50mm Lens Kit for 23C Series Enlargers
9177	50mm Lens Kit for 23C Series Enlargers, Full Frame



## Digital Timer

The new and improved Beseler digital timer provides the accuracy of a digital display with a blackout cover option for color printing environments. This new design has incorporated features that our customers have been requesting for years.

Features Include:

- Sealed buttons to eliminate infiltration of darkroom chemicals
- Bright easy to read digital display with glow in the dark legends
- Optional display cover for color printing environments (included)
- Improved accuracy and function for consistent timing
- Safelight receptacle
- One year limited warranty

## TIMER

8197	Digital Timer
------	---------------



## Beseler Developing Outfit

The Beseler Developing Outfit is an excellent complement to Cadet®II or Printmaker Enlargers. The kit consists of all the essentials to develop film and make prints. Includes film tank, film clips, safelight bulb, timer, 8" x 10" trays, print tongs, 32 oz. bottles, easel thermometer, funnel, beaker, squeegee, stirring rod, and print guide.



## Beseler Developing Trays

Give your darkroom a touch of color with the new Beseler® 8 x 10 developing trays. Made in the USA with durable, chemical resistant polypropylene. The convex guides keep prints from sticking to the floor of the tray. Complete with pouring corner to empty chemicals. Trays nest for stackability and easy storage.



## Dust Gun

Dust Gun 100 is a general purpose, ozone safe dusting product. Dust Gun 100 is ozone free and non-flammable. It is a pure, unblended, ultra filtered dusting product for use on film, C.D.'s, monitors, computers and scanners, and a multitude of other uses.

The Duster product is an economically priced, general purpose ozone safe duster.

The Super Dust Gun 100 is similar to the Dust Gun 100 except that it is a lot more powerful than any standard aerosol. Use where strong, concentrated cleaning power is needed.

The Dust Gun 100 Mini is now available which is perfect for traveling and on the go.

### 2.25 OZ DUST GUN 100

Back by popular demand, our 2.25oz portable canned air is perfect for on the go use. Fits in camera bags, purses, repair kits, brief cases and much more. Ideal for a quick, on hand shot of air for cameras, lenses, negatives, keyboards, laptops & cell phones.



## Archival Binders

Fully enclosed archival box to store slide, negative, C.D., and print pages secured to stay clean and safe. Binders are made from archival quality polypropylene with snap latches to keep dirt and moisture out. Binders are available with and without 3 rings.

## Replacement Parts

7000	Cam	7004	Belt "O"	7011	45M Refurbishing Kit
7001	Lock Elevating	7005	Glass Anti Newton	8095-10	Jam Nut, Pack of 10
7002	Gear	7007	45VXL Extension - 30"		
7003	Crank Elevating	7010	23C Refurbishing Kit		





# **BESELER** PHOTOGRAPHIC EQUIPMENT

**Charles Beseler Company**  
Photographic Equipment Division  
2018 West Main Street  
P.O. Box 431  
Stroudsburg, PA 18360

Phone: 800.237.3537  
570.517.0400  
Fax: 800.966.4515

[beseler.com](http://beseler.com)

