



Installation Instructions

CR-Series

Compact force sensor with flexible installation options for pulley

Document Version 2.00
Issue Date / Author 11/2019 / NS



**Diese Bedienungsanleitung ist auch in Deutsch erhältlich.
Bitte kontaktieren Sie Ihre nächstgelegene FMS Vertretung.**

1 Table of contents

1	TABLE OF CONTENTS	2
2	SAFETY INSTRUCTIONS.....	3
2.1	Presentation of safety information	3
2.1.1	Danger that could result in minor or moderate injuries.....	3
2.1.2	Note regarding proper function	3
2.2	General safety information	3
3	PRODUCT INFORMATION.....	4
3.1	Product description	4
3.2	Functional description	4
3.3	Scope of delivery.....	4
3.4	Order code	5
4	INSTALLATION.....	6
4.1	Installation options	6
4.1.1	PH Pilot mount.....	7
4.1.2	Flat mount.....	8
4.1.3	Installation bracket CA203.MB (accessory.....	8
4.2	Electrical connections	9
5	TECHNICAL DATA	10
5.1	Dimensions	11

2 Safety instructions

All safety related regulations, local codes and instructions that appear in the manual or on equipment must be observed to ensure personal safety and to prevent damage to the equipment connected to it. If equipment is used in a manner not specified by the manufacturer, the protection provided by the equipment may be impaired.

Do not stress the equipment over the specification limits neither during assembly nor operation. To do so can be potentially harmful to persons or equipment in the event of a fault to the equipment.

2.1 Presentation of safety information

The following safety symbols appear in this manual.

2.1.1 Danger that could result in minor or moderate injuries



Danger, warning, caution

Failure to follow wiring instructions in this manual may result in equipment damage or personal injury.

2.1.2 Note regarding proper function



Note

Note regarding proper operation
Simplification of operation
Ensuring function

2.2 General safety information



The force sensors may not be stressed over the specification limits neither during assembly nor operation. The unit's overload protection value may not be exceeded.



The attachment points for the force sensor on the machine frame must be properly designed. The bearings need to be appropriately mounted.



For proper installation and operation, follow the electrical wiring diagram and instructions in this manual.

3 Product information

3.1 Product description

The CR-Series force sensor offers compact dimensions and flexible installation options, and are designed for the measurement of tension on continuous material processing lines for filament materials. This product will accept a huge variety of different standard pulleys and therefore be applied versatilely. The product can be supplied with a Pilot or without a Pilot at the back the unit. In addition, flexible mounting options include the ability to install the unit utilizing either four fasteners from the front or a single fastener from the rear. The included dowel pin can also be incorporated between force measuring bearing and the machine frame to ensure proper unit orientation. For installations where a Pillow Block mount is required the optional bracket can be utilized. Shaft journal diameters of 8, 10 and 12 mm allow easy installation of standard pulleys. Standard pulleys are not supplied by FMS.

3.2 Functional description

The CR-Series force sensor combines the bearing seat and the force sensor within the same housing, thus minimizing the required installation space. The substantial overload protection translates to eliminated / minimized calibration issues due to machine upset conditions. The design includes dual bending beams, and this serves to eliminate the load specific influence of torque. The movement of the bending beams, which is proportional to the applied force, is detected by strain gauges arranged in a full bridge circuit and then converted into an electrical signal. This simple measurement principle delivers precise results even with low material tension and small web wrap angles. The Red Point, as located on the sensor body, should be aligned with the direction of the resultant force due to web tension.

3.3 Scope of delivery

Included in scope of delivery

Force sensor, straight connector (female), clip ring,
installation option PH: 4 pcs. DIN912 M6 x 40,
installation option FL: dowel pin

Options

- H14 right-angle connector in scope of supply, replaces straight connector
- H16 temperature range up to 120 °C (248 °F)
- H21 electrical connection with PG gland with 5 m (16 ft.) cable, replaces connector
- H31 for vacuum applications to 1E-7 hPa , 1E-5 Torr, temperature range up to 120 °C (248 °F)
- H32 vacuum to 1E-7 hPa , 1E-5 Torr, up to 150 °C (302 °F), with pg-gland and 5 m (16 ft.) cable
- H33 temperature range up to 150 °C (302 °F), with pg-gland and 5 m (16 ft.) cable
- PH Flange mount with 4 screws, pilot hole for centering
- FL Flat face of force sensor, without shoulder, single screw mount, with dowel pin

Accessories

Installation bracket, prefabricated cable (specify length) with connector (straight or right-angle)

3.4 Order code

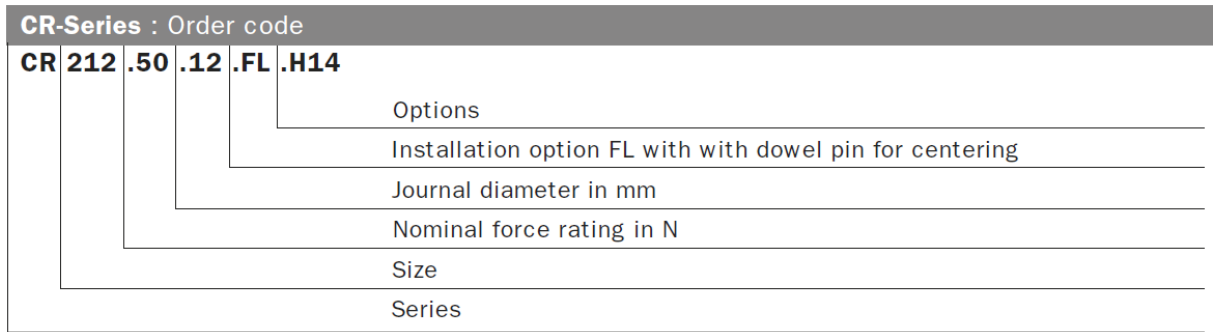

Figure 1: order code

Datasheet_CR_series.indd

4 Installation

Force sensors are defined as “partly completed machinery” according to the Directives 2006/42/EC, article 2. In order to assure a proper functionality of the parts and assure the essential safety requirements of operators working with it, the following conditions for the assembly must be met:



The force sensor may not be stressed over the specification limits neither during assembly nor operation. The unit’s overload protection value may not be exceeded.



The mounting points for the force sensor on the machine frame must be properly designed. The bearings need to be appropriately mounted.



For proper installation and operation, follow the electrical wiring diagram and instructions in this manual.

4.1 Installation options

The force sensors of the CR-series can be installed in two different ways.



Screw down on contact surface

The force sensor should only be bolted down where it has contact to the machine frame.

PH - Flansch mit Zentrierschulter
 PH - Flange with pilot hole for centering

FL - Flach mit Zentrierstift
 FL - Flat with dowel pin

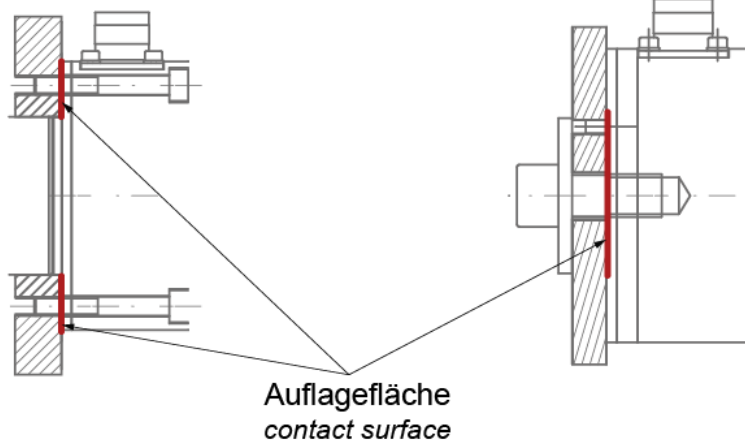

Figure 2: contact surface

4.1.1 PH Pilot mount

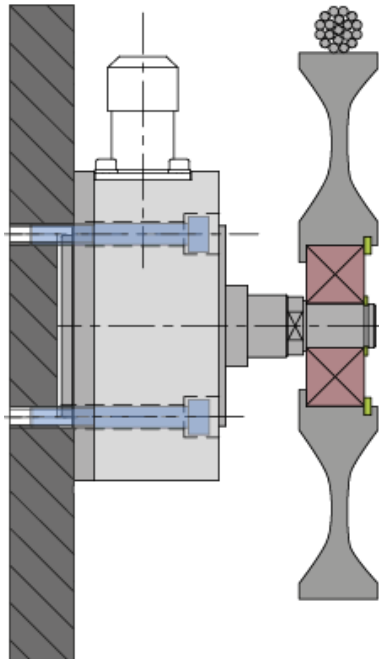

Figure 3: Pilot mount

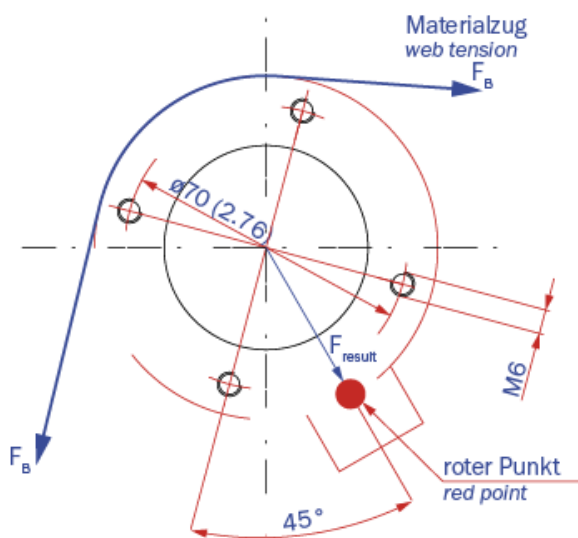
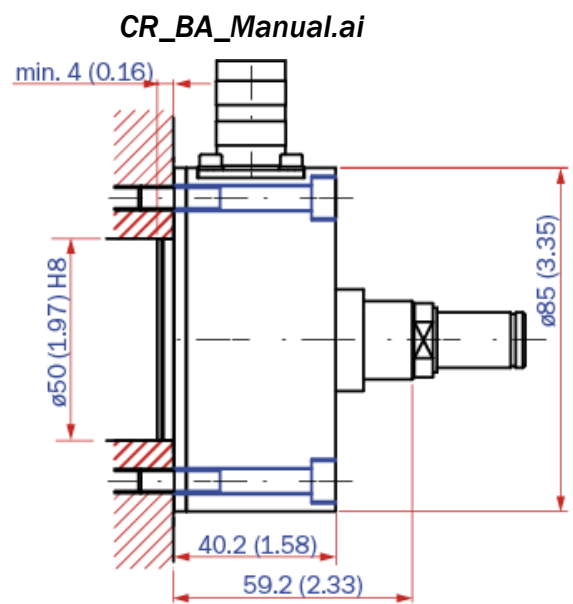

Figure 4: dimension machine frame for PH mount



CR_BA_Manual.ai

4.1.2 Flat mount

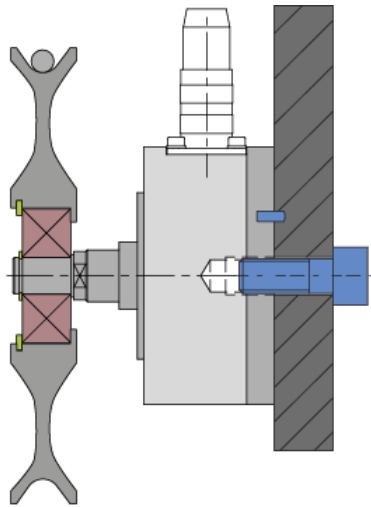

Figure 5: Flat mount

CR_BA_Manual.ai

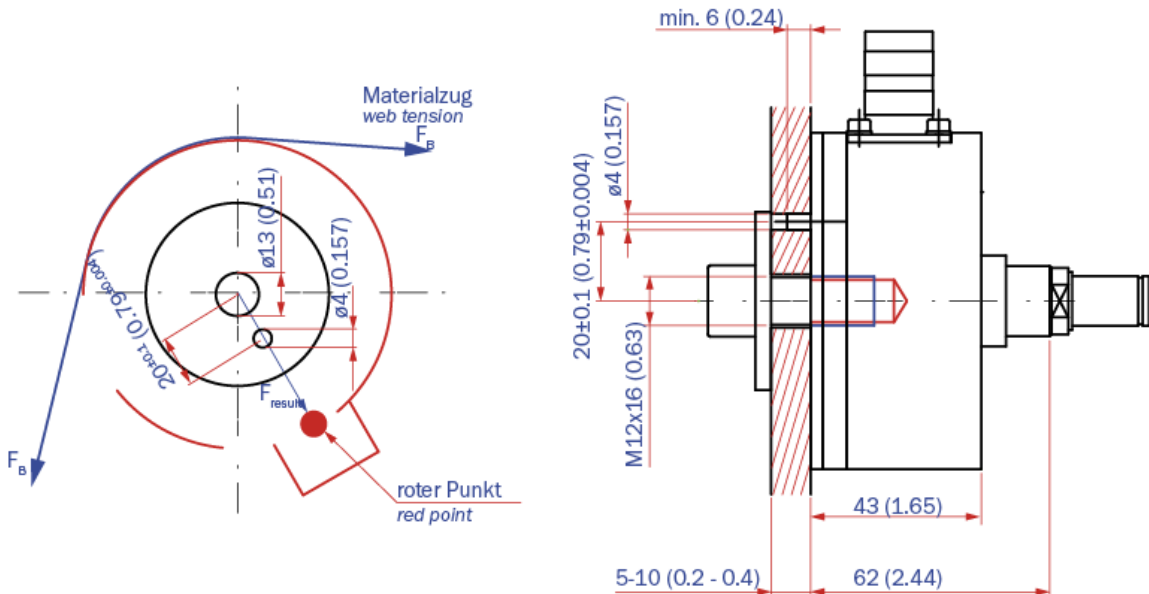
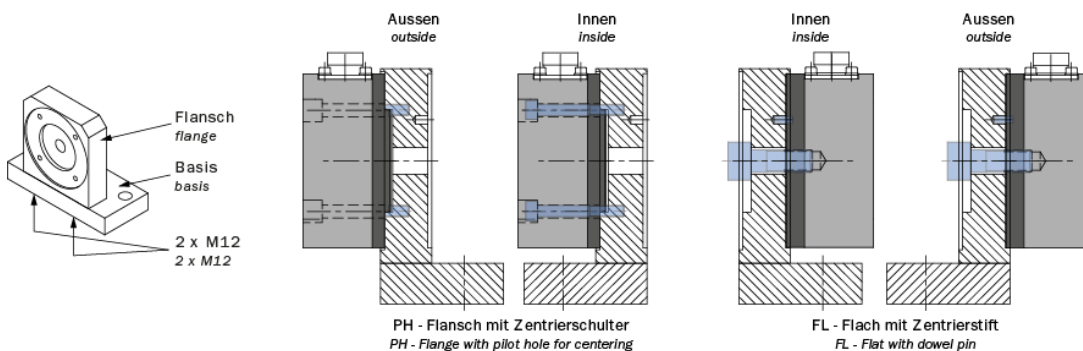

Figure 6: dimension machine frame for FL mount

CR_BA_Manual.a

4.1.3 Installation bracket CA203.MB (accessory



Flansch kann durch lösen der beiden M12 Schrauben um 180° verdreht werden
 flange part can be flipped 180° by loosening the two M12 screws

Figure 7: installation bracket CA203.MB

C_BA_Manual.ai

4.2 Electrical connections

Connection between the Force Measuring Rollers and machine controller is realized by means of a 5-pole cable with a cross-section of 0.25mm². The cable must be installed separate from power lines.

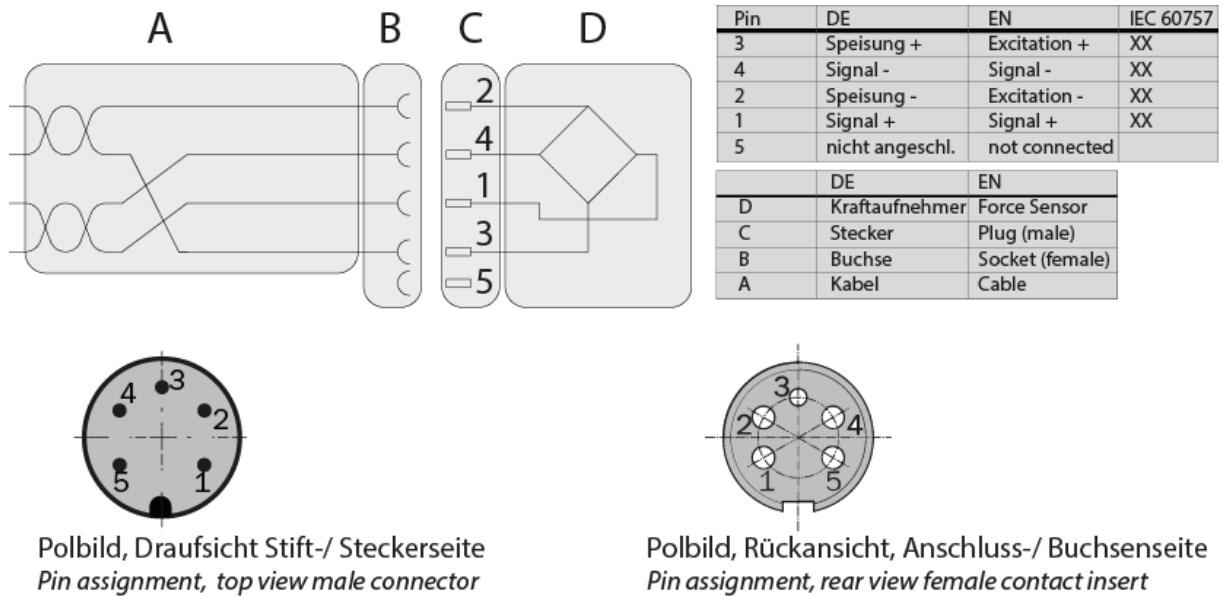

Figure 8: pin assignment M12

Pin_Assignment_Sensorkabel_Farben_Stecker.ai

5 Technical data

Technical data	
Sensitivity	1.8 mV/V
Tolerance of sensitivity	<± 0.5 %
Accuracy class	±0.5% of nominal force rating
Temperature coefficient	±0.1%/10K
Temperature range	-10 to +60°C
Input resistance	350Ω
Excitation voltage	1 to 12 VDC
Overload protection	10 times nominal force
Material	Stainless steel
Protection class	IP42
Electrical connection	Male receptacle, flange mounting, M14x1, 5-pole
Measuring range	30:1

Table 1: technical data

CR-Series : Deflection, Dimensions						
Sensors Type	Deflection mm (.in)	Dimensions mm (in.)				
		a	b	c	d	e
CR208	0.1 (0.0039)	8 (0.3149)	10 (0.3937)	7.8 (0.3071)	0.9 (0.0354)	76 (2.9921)
CR210	0.1 (0.0039)	10 (0.3937)	12 (0.4724)	17 (0.6693)	1.1 (0.4330)	86 (3.3858)
CR212	0.1 (0.0039)	12 (0.4724)	14 (0.5512)	17 (0.6693)	1.1 (0.4330)	86 (3.3858)

CR-Series : Nominal forces, Weight		
Sensors Type	Nominal force N (lbf.)	Weight kg (.lbs)
CR208	50, 125, 250, 500, 1000, 1500 (11, 27, 55, 110, 220, 337)	1.28 (2.82)
CR210	50, 125, 250, 500, 1000, 1500 (11, 27, 55, 110, 220, 337)	1.28 (2.82)
CR212	50, 125, 250, 500, 1000, 1500 (11, 27, 55, 110, 220, 337)	1.28 (2.82)



FMS Force Measuring Systems AG
 Aspstrasse 6
 8154 Oberglatt (Switzerland)
 Tel. 0041 1 852 80 80
 Fax 0041 1 850 60 06
 info@fms-technology.com
 www.fms-technology.com

FMS USA, Inc.
 2155 Stonington Avenue Suite 119
 Hoffman Estates, IL 60169 (USA)
 Tel. +1 847 519 4400
 Fax +1 847 519 4401
 fmsusa@fms-technology.com

FMS (UK)
 Aspstrasse 6
 8154 Oberglatt (Switzerland)
 Tel. +44 (0)1767 221 303
 fmsuk@fms-technology.com

FMS (Italy)
 Aspstrasse 6
 8154 Oberglatt (Switzerland)
 Tel. +39 02 39487035
 fmsit@fms-technology.com