



Koblenz: 15.01.2001

Summary report

Planned object: Mechanical Mine clearance device

Identification nr.: 2350-14390

Manufacturer: Fa. Hydrema

Model: 910 MCV

Project Nr.: E/K43A/00059/Q5204

Task: Establishment of mine test lanes in two distinctly different types of soil and execution of clearance trials.

Report: Pages: 64 Pictures: 39 Tables: 27

Author: TRAR Theimer Department: 230 Phone: 19 73

Outcome: The 910 MCV cleared all mines through the tiller's contact
The clearance depth was mainly less than 30 cm.

(Signature)

Remarks: Distribution list: BWB - KG IV 3 3x
WTD 51 - 230 1x
Translation into English: M. Garotta, ITEP Secretariat

Index

1.	Task definition	3
2.	Test fields and time frame of the trial.....	3
2.1.	Test fields:.....	3
2.2.	Time frame.....	3
3.	Brief description of the 910 MCV	3
4.	Execution of the trials	5
4.1.	Overview	5
4.2.	Pre-trials.....	5
4.3.	Clearance trials.....	6
4.3.1.	Overview	6
4.3.2.	Mines	6
5.	Results	8
5.1.	Technical data	8
5.2.	Pre-trials.....	8
5.3.	Clearance trials.....	9
5.4.	General observations:.....	9
5.5.	The test lanes after the clearance process	10
5.6.	Clearance of roads	10
5.7.	Transportation.....	10
5.8.	Preparation for the clearance	10
6.	Summary.....	11

[Annex 1 Time schedule](#)

[Annex 2 Lab report on soil analysis](#)

[Annex 3 Ground profile of the pre-trial at Schmidtenhöhe \(Koblenz\)](#)

[Annex 4 Test lane for the clearance trials WTD 91 \(Meppen\)](#)

[Annex 5 Test lane for the clearance trials Schmidtenhöhe \(Koblenz\)](#)

[Annex 6 Ground profile of the clearance trials on Schmidtenhöhe \(Koblenz\)](#)

[Annex 7 Mine distribution Plan WTD 91 \(Meppen\)](#)

[Annex 8 Mine distribution Plan Schmidtenhöhe \(Koblenz\)](#)

[Annex 9 Technical data of the clearance devices](#)

[Annex 10 Clearance depth of the pre-trial on Schmidtenhöhe \(Koblenz\)](#)

[Annex 11 Results of the vibration measurements](#)

[Annex 12 Employed time for clearance/Further conditions for WTD 91 \(Meppen\)](#)

[Annex 13 Employed time for clearance/Further conditions for Schmidtenhöhe \(Koblenz\)](#)

[Annex 14 Clearance depth of the trials on Schmidtenhöhe \(Koblenz\)](#)

[Annex 15 Pictures](#)

[Annex 16 Assessment of the clearance trials \(report WTD 91\)](#)

1. Task definition

The army requires a mine clearance device that is able to clear in a fast and safe way known minefields or areas suspected as mine-affected, in environments requested to be used as water treatment areas, airfields, and camps.

In the context of a trial the clearance efficiency (and safety) of COTS (commercial of the shelf) mine clearance devices from different types and manufacturers under equal conditions shall be compared.

In principle, the following works will be conducted:

- Definition of a test program for the assessment of the clearance efficiency
- Development of a plan for the placement of mines and the supply of surrogate mines.
- Execution of terrain survey
- Execution of a soil analysis
- Marking of the area for pre-trials and clearance trials
- Placement of surrogate mines according to the mine distribution plan
- Execution of the pre-trials and clearance trials in two distinctly different types of soil.
- Establishment of technical data
- Measurements of the vibration
- Transportability of the device
- Assessment of the results and evaluation of the destruction capacity of the mines
- Documentation of the results
- The definition of assessment criteria including the formulation of a proposal for the development and purchase of a device, which was discussed among the purchaser, the manufacturer, and WTD 51, will not be object of this report.

2. Test fields and time frame of the trial

2.1. Test fields:

Test field: WTD 91, Meppen (Hufeisenwall) (Military Technical Centre 91)

Test field: Standortübungsplatz (StÜbPl) Schmidtenhöhe, Koblenz (Military Training Area)

2.2. Time frame

Preparation for the trial:	25. -- 39. week 2000
Execution of the trial:	see Annex 1 (Work Plan schedule status as of 26.09.2000)
Clearance results:	42. - 52. week 2000

3. Brief description of the 910 MCV

([see Annex 15 picture 1 to 6](#))

The MCV 910, designed for clearing surfaces is a mobile mine clearance device accredited also for the public road traffic. On the rear part it presents a special rotating

clearance device, hydraulically operated. The clearance takes place through the rotation movement of the flail, which should, through this action, detonate the mines. When working, the vehicle moves in the opposite direction to road movement and it can be either operated through a computerized automatic pilot steering system or manually using a joystick.

The device in object, having two fixed axes, disposes of a pivot steering.

The machines gets powered by two identical but independently working 136 kW (185-hp) Perkins turbo inter-cooler engines, one for driving and the other for flailing activity.



Manufacturer: Fa. Hydrema
Kromsdorfer Str. 18
99427 Weimar/Thüringen

4. Execution of the trials

4.1. Overview

Since commercially available mine clearance devices were being tested in order to compare their clearance efficiency, almost equal test conditions for all the devices had to be created.

The following requirements were satisfied:

- Nearly equal soil types
- Nearly equal terrain slopes
- Equal pre-trial test lanes and mine test fields

The trials were conducted in comparable weather conditions.

Since the trials had to be executed in two completely different soil types, they were conducted on soil with a very high sand content in the WTD 91 in Meppen and on soil with high clay content on the StOÜbPI in Koblenz.

The results of the detailed soil surveys, showing almost equal soil conditions, are attached as [Annex 2](#).

On both soil types, pre-trials and clearance trials were conducted. The 910 MCV was operated by the manufacturer's staff and was controlled from the armoured driver's cabin.

During the trial the following security distances given by the manufacturer had to be kept.

Nr.	Mine clearance device	Side	Front	back
1.	910 MCV	100 m	100m	100 m

4.2. Pre-trials

During the pre-trials the mine clearance device in object once covered a distance of 150m. The installed clearance depth that the flail system had to maintain had to be at least 30cm.

Next to the needed time, the clearance width and depth were determined. On the StOÜbPI Schmidtenhöhe in Koblenz even the vibration behavior of the driver's cabin (co-contractor WTD 41) was evaluated.

The pre-trials were conducted in the same way at the WTD 91 and at the StOÜbPI Schmidtenhöhe in Koblenz.

The area of WTD 91 is almost plain with grass-moss vegetation.

The grass area of the StÜbPI Schmidtenhöhe shows limited changes in terrain topography along and across the test lanes. [Annex 3](#) (diagram) shows a representation of the test field topography along the test lane .

4.3. Clearance trials

4.3.1. Overview

At the clearance trials a test lane was given to the manufacturer. The test lane was composed of a starting track, the mine test fields I to III, and an ending track. The device was positioned at the beginning of the starting track and had to work all through the test lane. The clearance process was always conducted in one direction. As the test lane had been covered, the vehicle drove back in the same lane, placed itself in front of the test lane and cleared the next part of the test lane overlapping with the already cleared track and then cleared the next track. In doing so, the company chose an overlapping of about 50 cm.

The device had to reach at least a flailing depth of 30 cm.

The prepared clearance lane at WTD 91 is provided in [Annex 4](#), whereas the one at StÜbPI Schmidtenhöhe in [Annex 5](#).

The topography along the test lane on the StÜbPI Schmidtenhöhe is visible in [Annex 6](#) and the crosswise slope in the context of the mine test fields amounts to:

Field 3 910 MCV, Fa. Hydrema 2,4° to 2,7°

4.3.2. Mines

On the test field of WTD 91 the mines were distributed according to the distribution plan as in Annex 7, and on the StÜbPI Schmidtenhöhe according to the mine distribution plan as in see Annex 8.

In the following table the mines distributed in the test field of WTD 91, in Meppen and in the one of StÜbPI Schmidtenhöhe are listed.

Name	Type	Quantity		Comments
		WTD 91 Meppen	Schmidtenhöhe Koblenz	
Anti-personnel blast mines	DM 11	20	0	
	DM 18	0	14	
	PPM-2	15	14	
Mine fuse	DM 56 A1 B1	5	3	With tripwire
Anti-personnel fragmentation mines	DM 31	5	5	
Anti-tank mines	DM 21	5	5	
	TM 62P3	5	5	

[See Annex 15 picture 13 and 14](#)

For the clearance trials blast surrogate mines were used. In the weapons arsenal of WTD 91 the explosive content was taken out of the mines and was replaced by non-explosive material.

[\(see Annex 16\).](#)

In order to understand if the mines' fuses were initiated by the clearance vehicles, the mines in the WTD test field were prepared as follows:

- Anti-Tank blast mines (black powder) DM 21 with blast indicating surrogate
TM 62P3 with fuse chain
- Anti-personnel blast mines DM 11 with detonator
PPM-2 with detonator
- Anti-personnel fragmentation mines DM 31 with propelling charge
- Fuse for tripwires DM 56 A1B1 with additional detonator

For the trials on the StOübPI Schmidtenhöhe test field, inert mines were employed.

The tripwires used for the trials at StOübPI Schmidtenhöhe were connected to live fuses, which produced small amounts of smoke at initiation.

5. Results

5.1. Technical data

The most important technical information about the machine is listed hereafter.

Data on the machine:

	910 MCV Fa. Hydrema
Measurements working position	
Length	10000 mm
Width	4830 mm
Height	<2700 mm
Weight	18 t
Transport	
Length	9200 mm
Width	2800 mm
Height	2700 mm
Weight	18 t
Velocity	35 km/h
Dismantling process for transportation	Not necessary
Engine capacity	136 KW under-carriage 136 KW drive mode

Technical clearance data

The technical clearance data of the mine clearance device are listed in [Annex 9](#).

5.2. Pre-trials

WTD 91 Meppen

The machine took the following listed time to cover a distance of 150m:

910 MCV, Fa. Hydrema 38 min (of which 10 min. in stop position since the engine overheated and switched off, due to soil blocking the slatted grill. By changing the driving, the grill was able to operate a self cleaning so that the clearance process could re-start.)
(see [Annex 15 picture 12](#))

The clearance width corresponds to the data given by the manufacturer.

The trials for the clearance depth ([see Annex 15 picture 15](#)), tested by carrying out spot checks, gave the following results:

910 MCV, Fa. Hydrema: 40 and 24 cm

The presented device had no traction problems.

Schmidtenhöhe Koblenz

The machine took the following listed time to cover a distance of about 115 m:

910 MCV, Fa. Hydrema: 45 min

For security reasons the starting point had to be moved by 45 m. As a consequence a shorter distance of about 115m was available for the pre-trials. At the end of the test lane, two lanes were cleared at an angle of 30 degrees with the test lane.

The clearance width corresponds to the data given by the manufacturer.

The clearance depths are represented in the sketch of annex 10.

The 910 MCV had traction problems while trying to reach the slightly curved starting position, whereas during the pre-trial no traction problems were visible.

The results of the vibration measurements in the driver cabin are visible in [Annex 11](#)

5.3. Clearance trials

The needed time frame, as well as the needed working conditions for clearance are attached as annexes 12 and 13 for the trials at WDT 91 and at StOÜbPI Schmidtenhöhe, Koblenz respectively.

Mine search:

Immediately after the end of each clearance trial all remaining on-surface mines and fragments were collected and stored.

In order to search for mines and mine fragments left behind in the ground, a rock collector for sieving the ground was used. The detailed description is contained in [Annex 16](#).

The description of the mine collection using a rock collector ([see Annex 15 picture 30 and 31](#)) and the evaluation of the remaining mines and components after the clearance trials done by WDT 91 – 360, are attached as [Annex 16](#).

In order to assess the clearance depths, the mine fields were surveyed. The results are shown in [Annex 14](#).

5.4. General observations:

During the clearance process the blade of the flail system must be manually moved +/- 5°, in horizontal direction in order not to leave ridges of untouched soil with mines in it behind. According to the manufacturer Fa. Hydrema, this function will get automatized in the second version of the machine.

The system itself sometimes swings to the side.

When flailing too deeply, the rotation velocity of the clearance equipment decreases considerably.

In order to reach the required clearance depth of 30 cm, the engine capacity has to be increased.

The condition of the clearance equipment after the trials on the Schmidtenhöhe, Koblenz test field is illustrated in [Annex 15 picture 10 and 11](#).

Operation: The operating of the machine from the driver cabin created no problems, notwithstanding the view conditions ([see Annex 15 picture 16 to 18](#)) being very limited due to the protection blade. The programming of the soil characteristics in the on-board computer requires however much experience.

5.5. The test lanes after the clearance process

The condition of the test lanes and moving tracks after the clearance trials are presented in the pictures hereafter:

910 MCV ([see Annex 15 picture 7 to 9](#))

5.6. Clearance of roads

By changing the direction of the rotating flail (rotation away from the vehicle), the mine clearance device 910 MCV can also clear paved and unpaved roads by flailing the mines occurring in the tracks (works similar to the clearance principle present in the demining machine Keiler).

Round flails were mounted at the chains for this trial.

Trial 1

On unpaved roads 5 out of the seven used dummy mines were destroyed and 2 were thrown to the side ([see Annex 15 picture 19 and 20](#)).

Trial 2

On paved road all the 7 used dummy mines were destroyed (See Annex 15 picture 21). ([see Annex 15 picture 21](#)).

5.7. Transportation

([see Annex 15 picture 22](#))

The transportation between work sites: WDT 91, Meppen to StOÜbPI Schmidtenhöhe, Koblenz occurred by a civilian transportation company.

What the dimensions and the weight of the 910 MCV concerns, its transport does not create any problems.

5.8. Preparation for the clearance

After the transportation of the vehicle, several arrangements have to be completed in order to have the machine ready for clearance.

By being accredited for public road traffic, the 910 MCV can easily be deployed to the area of operation.

After having reached the area of operation the following steps are necessary to convert the system from the transport position ([see Annex 15 picture 23](#)) to the operating status:

1. Loose strain chains

2. Loose the fuse of the rotating assembly on the vehicle's tail ([see Annex 15 picture 24](#)).
3. Loose the screw fuse on the rear handle bar ([see Annex 15 picture 25](#)).
4. Rotate flail pushing frame and blade of 90° ([see Annex 15 picture 26](#)).
5. Flap flail pushing frame and blade to the stop position ([see Annex 15 picture 27](#)).
6. Lower flail pushing frame to the clearance position – starting position is reached - ([see Annex 15 picture 28 and 29](#)).
7. For road clearance the blade will be lowered until the rollers touch the ground.
For terrain clearance the rollers have to be dismantled first.

The conversion of the system from the transport position to working one takes not more than 5 minutes.

6. Summary

The mine clearance device 910 MCV, Fa. Hydrema (even if the flail engine for demining activities is under-powered) was able to cope with the planned clearance works in sandy terrain.

The 910 MCV detonated the buried and unburied mines through the contact of the flail.

In terrain with clayey soil the machine demonstrated to have the same good characteristics as in sandy terrain.

The operation of the 910 MCV needs lots of experience.

WTD 51 - 230

Koblenz, 26.09.2000



Trial of Mine clearance device

Schedule from 28.09. to 30.10.2000

Nr.	Procedure	W 39			KW 40								KW 41							KW 42							KW 43							K				
		28.	29.	30.	01.	02.	03.	04.	05.	06.	07.	08.	09.	10.	11.	12.	13.	14.	15.	16.	17.	18.	19.	20.	21.	22.	23.	24.	25.	26.	27.	28.	29.		30.	31.	01.	
1	Delivery of the devices to WTD 91	28.09.																																				
2	Preparation of the devices by companies																																					
3	Holiday																																					
4	Information on the devices by the manufacturer																																					
5	Execution of the pre-trials																																					
6	Technical service																																					
7	Execution of the clearance trials																																					
8	Technical service																																					
9	Transportation of the devices from WTD 91 - WTD 51																																					
10	Preparation of the devices by companies																																					
11	Information on the devices by the manufacturer																																					
12	Execution of the pre-trials																																					
13	Technical service																																					
14	Execution of the clearance trials																																					
15	Technical service																																					
16	Enquiry of technical data etc..																																					
17	Dismantling process by companies																																					

Legend: Nr. 1, 9 and 17 Transportations
 Nr. 2 to 8 Trials on WTD 91 in Meppen
 Nr. 10 to 16 Trials on Schmidtenhöhe in Koblenz

Anhang 2

	WEHRTECHNISCHE DIENSTSTELLE FÜR PIONIER- UND TRUPPENGERÄT - LABOR FÜR BODENMECHANIK -	WTD 51
Koblenz, den 04.12.2000		
<h2>Laborbericht</h2>		
Berichts-Nr.	: 12/00	
Vorhaben	: Bodenuntersuchungen Minenräumergerät	
Auftrag	: WTA - Nr.: Q/K43A/00059/Q5204 WTD 51 - 230	
Aufgabe	: Untersuchung von 16 Testbahnen auf ihre Kornverteilung (Siebung und Schlämmung) und bodenmechanischen Eigenschaften	
Bearbeiter	: TROS Schlemmer	Org.-Einheit: Dez 230
	Telefon	
	Öffentliches Netz : (0261) 400-1999/1981	
	AllFspWN Bw : 4424-1999/1981	
Berichtsumfang	Seiten : 246	
	<p>Im Auftrag</p>  Schlemmer	
Bemerkungen:	Verteiler: WTD 51-230 2x	

1 Work description

Assessment of soil characteristics of 2x8 test lanes on two mechanically different soil types.

Assessment of the test lanes on their grain size distribution and mechanical soil characteristics. The scope of these analyses was the creation of 2x8 homogenous test lanes for the choice of four mine clearance devices on two mechanically different soil types.

2 Execution of the trials

The trials were executed in the test field (WTD 91, Meppen and StOÜbPI Schmidtenhöhe, Koblenz) and in the laboratory of the WTD 51.

In the field the following trials were executed:

- Survey according to DIN 4094,

- Soil drilling according to DIN 4021,

- Determination of the soil compactness according to DIN 18125 part 2

Laboratory tests:

- Determination of the grain size distribution according to DIN 18123,

- Determination of the flow and rolling borders according to DIN 18122,

- Determination of the water content according to DIN 18121 part 1

3 Summary of the results

The analyzed soil of the 4 test lanes (for the clearance trials) and of 4 test lanes at WTD 91 in Meppen (for the pre-trials) can be described as a homogenous sand having silt and clay content. The silt and clay contents are very little and therefore irrelevant. The soil compactness and the soil water content were almost on all test lanes identical.

The analyzed soil of the 4 test lanes (for the clearance trials) of the StOÜbPI Schmidtenhöhe, Koblenz can be described as a homogenous soil having clay, sandy and gravelly characteristics. The soil compactness and its soil water content were almost on all 4 test lanes (for the clearance trials) the same. The soil of the 4 test lanes for the pre-trials was sandier and more gravelly, with from time to time stony clay.

Summarising, the results clearly show that the soil properties, grain size distribution as well as mechanical characteristics, on both test fields WTD 91 Meppen and StOÜbPI Schmidtenhöhe, Koblenz, were for all 4 devices identical, so that from the soil mechanics point of view, the devices were tested under the same operating conditions.

**Ground profile of the pre-trials lane area
StÜbPI Schmidtenhöhe Koblenz**

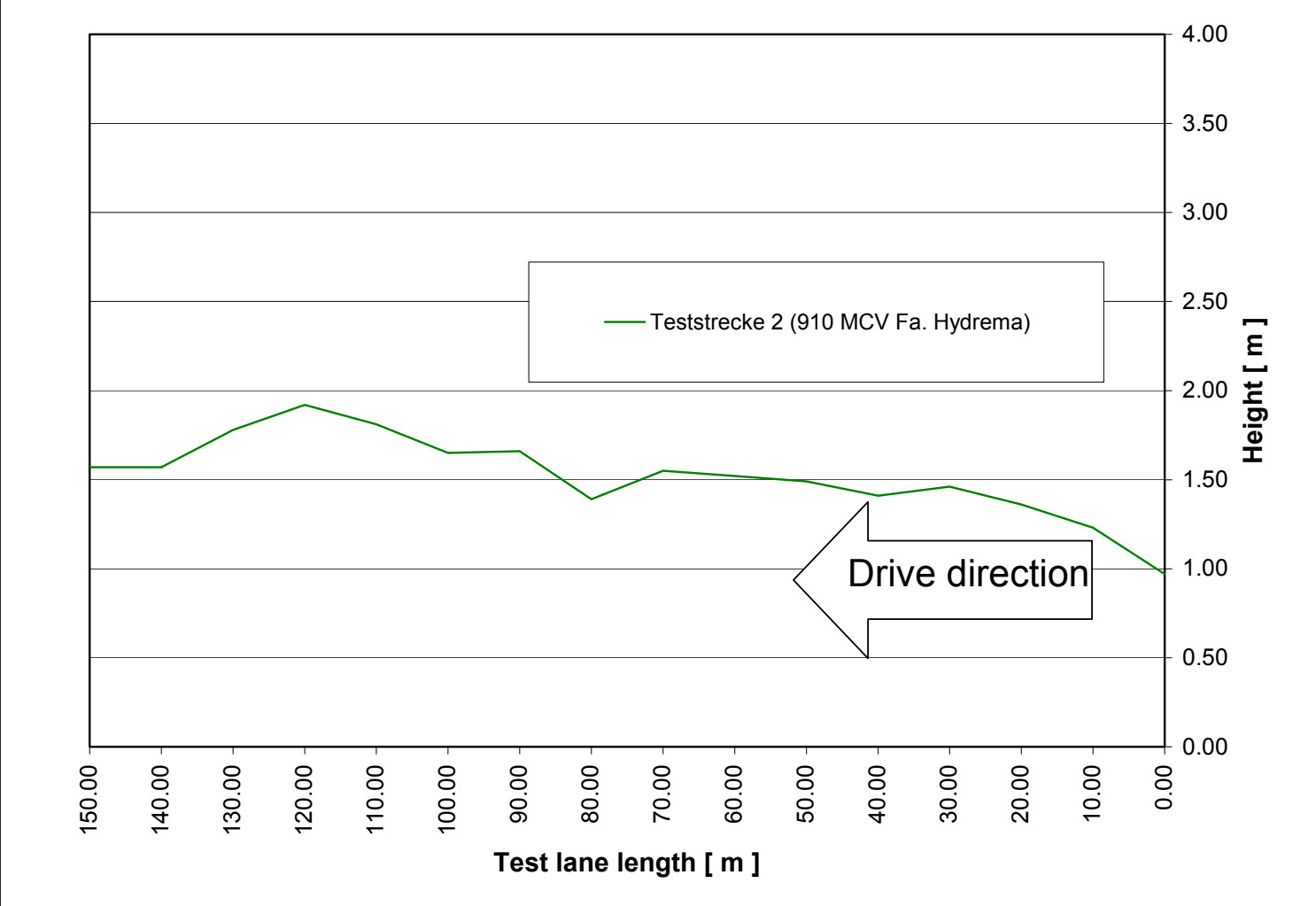

Teststrecke für Räumversuche WTD 91, Meppen

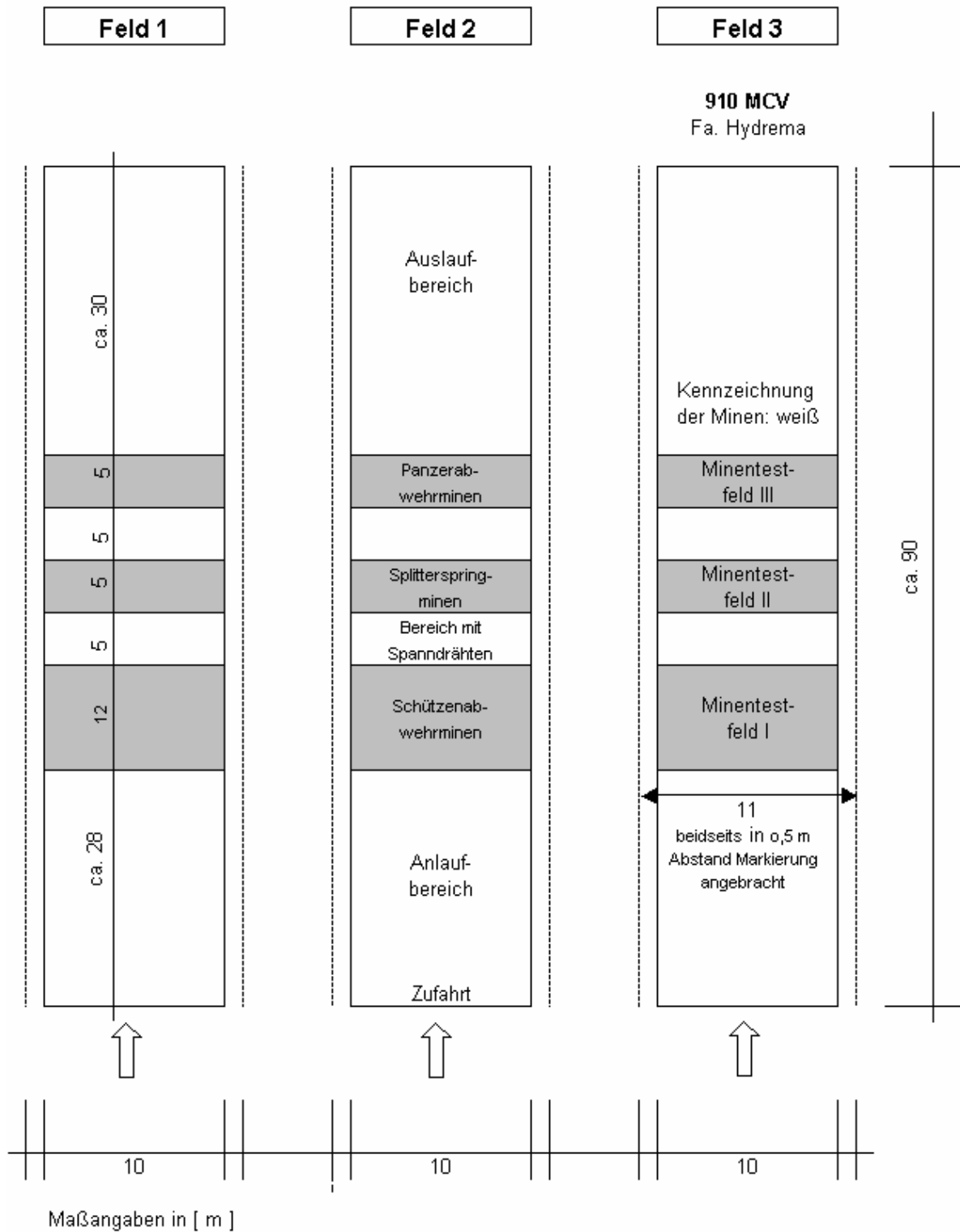

Teststrecke für Räumversuche StÜbPI Schmidtenhöhe, Koblenz

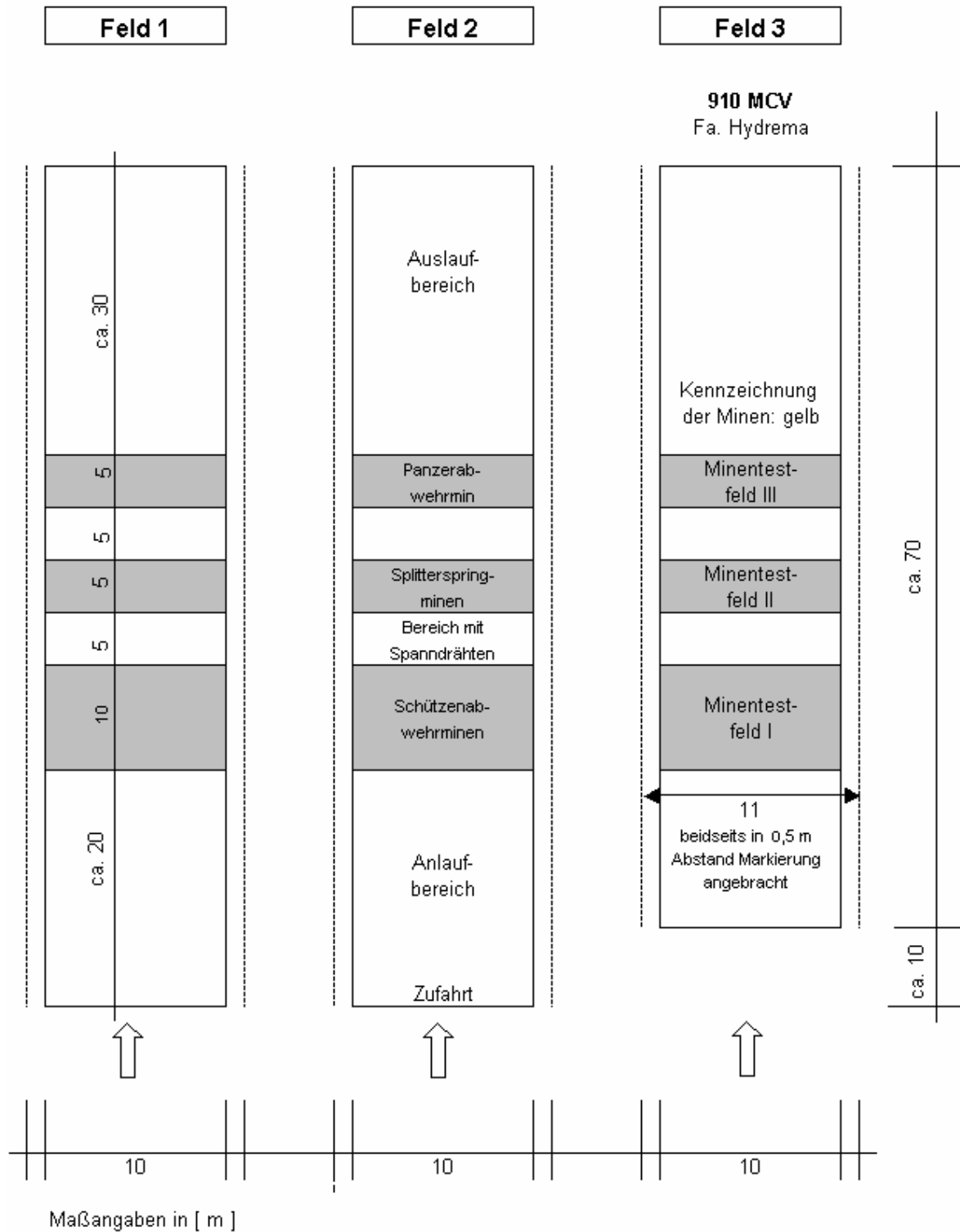

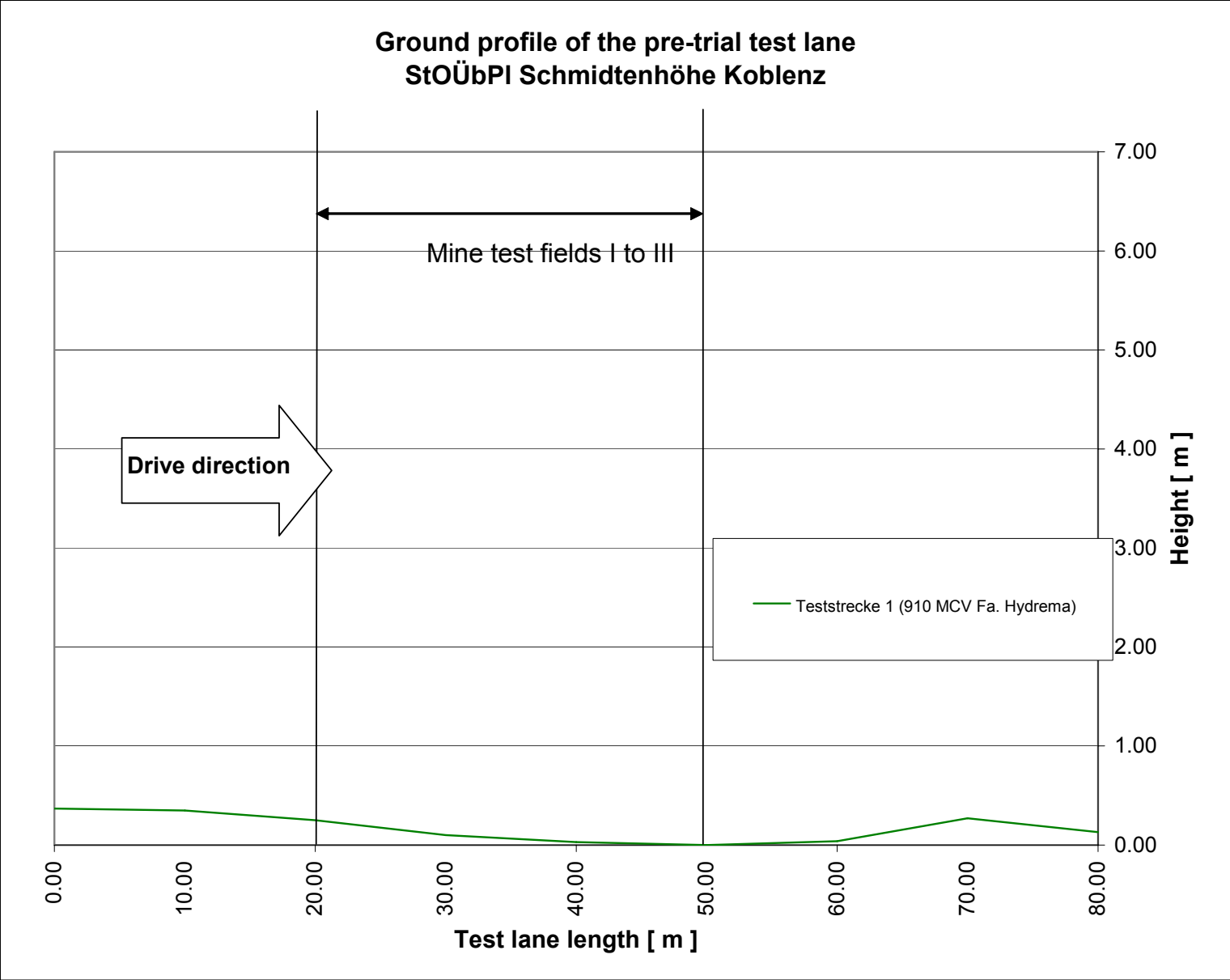

Minenverlegeplan WTD 91, Meppen

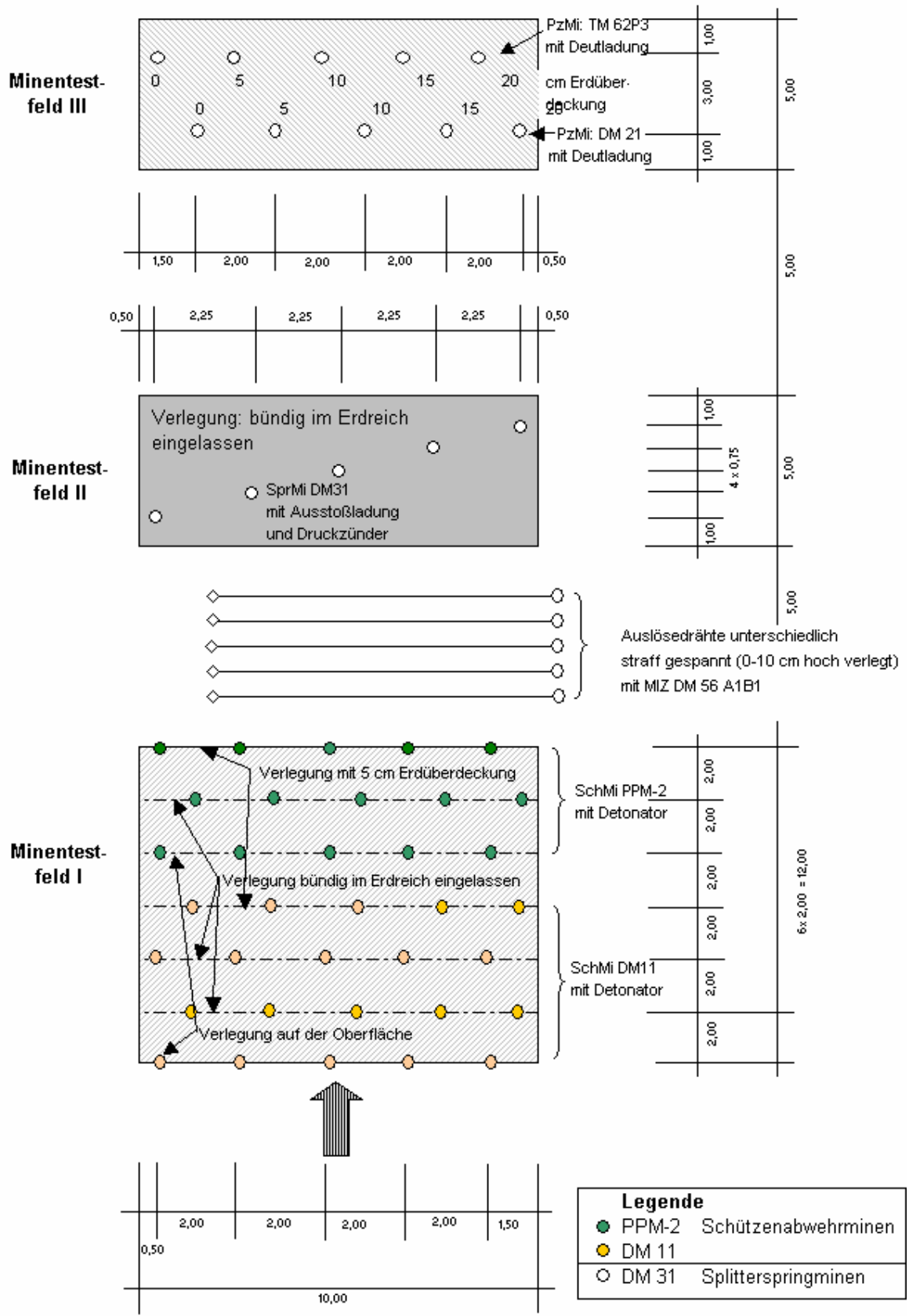

Minenverlegeplan StOÜPI Schmidtenhöhe, Koblenz

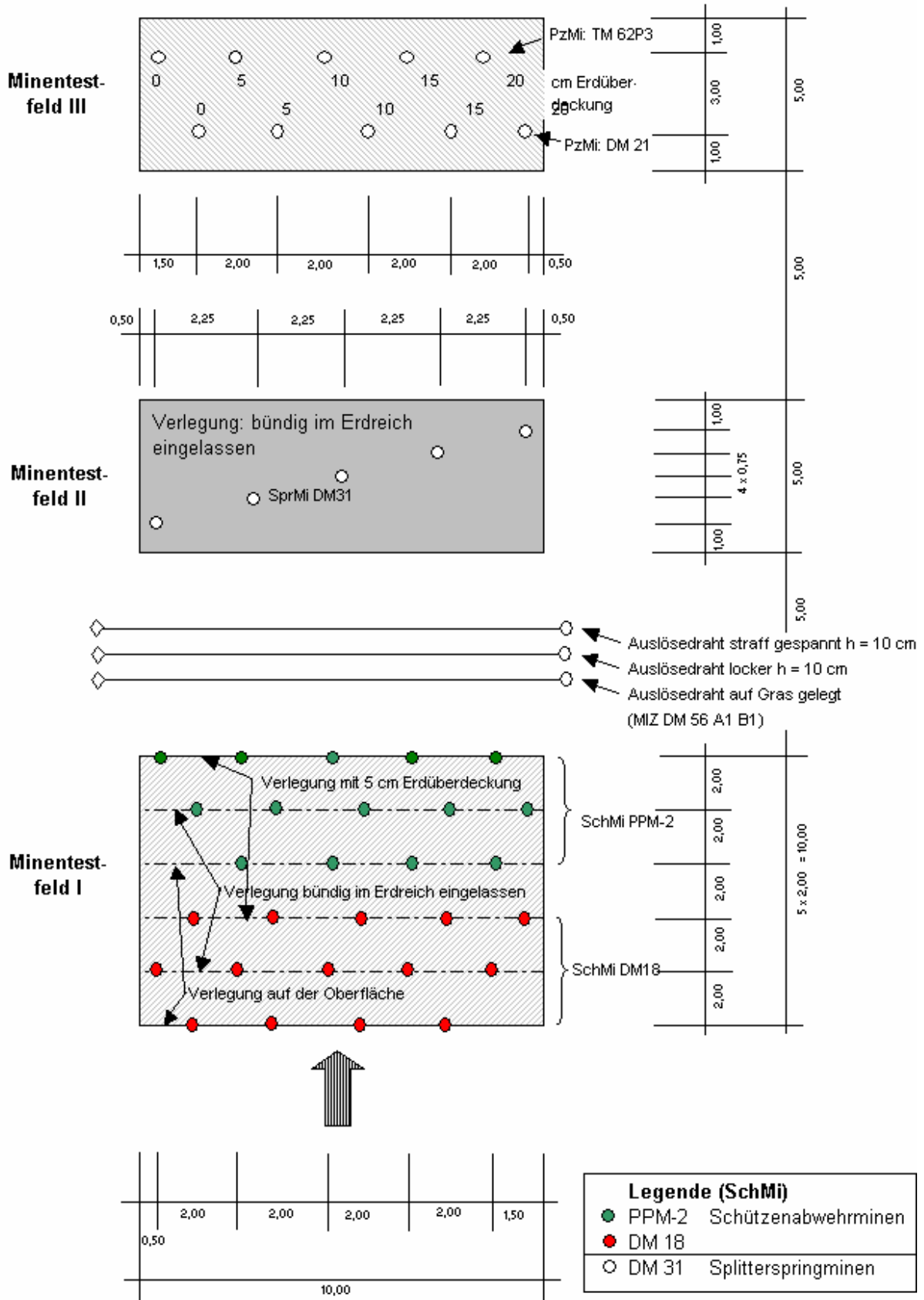

Technische Räumdaten

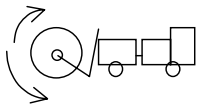
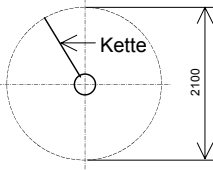
	910 MCV Fa. Hydrema
Räumprinzip	Schlegel
Bedienung	von Fahrerkabine
Reichweite Funkfernsteuerung	keine
Drehrichtung	
Walzen- durchmesser	2100 mm Kettenlänge 900 mm 
U/min	max 350 200 - 300 Räumbe- trieb
Anzahl Fräsköpfe/ Schlegel	72 Schlegel davon 36 zylindrisch und 36 Elefantenfüße im Wechsel
Räumbreite	3,50 m
Räumtiefe	bis 30 cm
Räumgeschwindig- keit/Räumleistung	max 12 km/h Straße räumen max 1400 m/h Flächenräumen
dynamischer Spalt	0 cm bei Lenkbewegung von +/- 5° während des Räumvorgangs
Minensprengkraft	bis 10 kg TNT
Kraftstoffverbrauch während der Räumung	ca. 60 l/h
Besonderheiten	1. Eingebauter Hoch- druckreiniger mit

Vergleichserprobung Minenräumgeräte Schmidtenhöhe Koblenz
Vorversuche: Frästiefen in cm

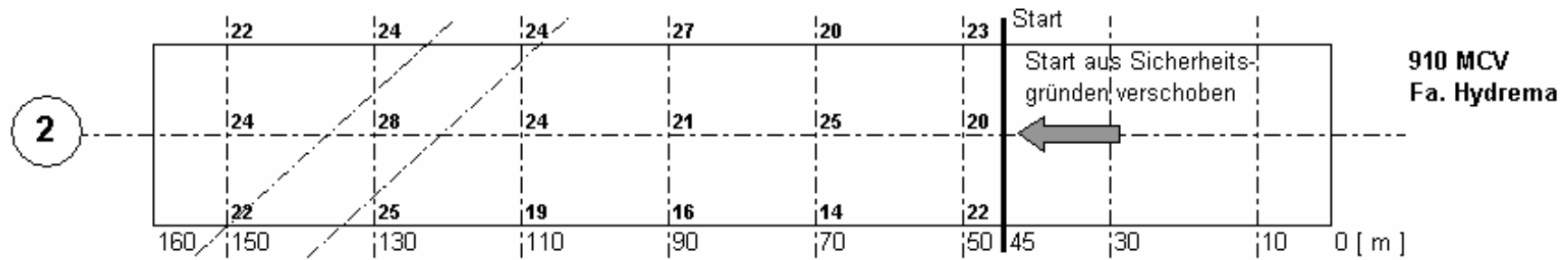

Anhang 11

**Wehrtechnische Dienststelle
für Kraftfahrzeuge und Panzer**

Anlage zum Untersuchungs-/
Erprobungsbericht

Trier, den 15.11.2000

App.: 2633

Dok.-Nr.:

Dezernat: 150

Verfasser: Philippi

Versuchs- und Meßergebnisse

WTA - Nr.:

TA - Nr.: 01457/001

Auftragstext: Humanrelevante Schwingungsmessungen
auf dem Fahrersitz

Der Bericht besteht aus 3 Seiten.

Bemerkungen:

.....
Verfasser

1. Description of the device to be tested

Hydrema Fa. Mine clearance device is based on a wheeled chassis.

2. Description of the test field

The analyses of the vibrations were conducted during the clearance process on a test area in Koblenz (Schmidtenhöhe).

3. Measured points

The acceleration was acquired from the base of the driver's seat and from the seat itself, each time from three directions.

4. Description of the instruments employed for measuring

DAT-Recorder Sony PC 208 (S-Nr.: 070000-066005)

Seat cover of the company B&K Type 4322 (S-Nr.: 055003)

Acceleration receiver, B&K Type 4321 (S-Nr.: 030116-044001)

Calibrator, B&K Type 4294 (S-Nr.: 030119-004002)

Real time analyser, B&K Type 2143 (S-Nr.: 070000-02211)

5. Method

The analyses were conducted according to the ergonomic SEV 09-40 of the NATO procedure for the standard testing of mechanical equipment. The results of the measurements were evaluated according to ISO 2631-1 of 1997. The assessment of the human relevant vibration load follows the assessment model of VDI 2057 in connection to the 2. Regulation for professional disease (bulletin 2110) of May 1993.

For the assessment only the data delivering the highest results was used, (values of the Z-direction) according to VDI 2057.

[Table 1](#) lists the acquired Keq-values with the relative allowed exposure times in minutes for the maintenance of proper health conditions (Tgmin). The arithmetic average values of the three trial repetitions were calculated, see [Table 2](#). Since a particular attention was given to the transmission of the vibration to the driver seat, the so-called seat transmission factor SEAT was calculated, see [Table 3](#).

6. Results

In the following tables the obtained Keq-values, of the accelerations, taking into consideration the relevant allowed exposure times for the maintenance of proper health conditions, together with the arithmetic average values, are represented.

Test lane: grassland	v in km/h	Driver seat Base			Driver seat Seat			TGmin
		KX	KY	KZ	KX	KY	KZ	Z
1. Trial	about 0,5	4,8	2,8	17,2	3,4	5,0	9,8	> 8 h
2. Trial	about 0,5	6,4	2,8	22,6	3,4	6,7	12,8	> 8 h
3. Trial	about 0,5	7,6	3,1	21,0	3,4	6,4	10,6	> 8 h

Table 1: Keq-values (Model Hydrema)

During the clearance process						
Test lane: grassland	Driver's seat Base			Driver's seta Seat		
	KX	KY	KZ	KX	KY	KZ
Hydrema	6,3	2,9	20,3	3,4	6,1	11,1

Table 2: Arithmetical average Keq-values

7. Calculation of the transmission seat factors SEAT

$$\text{SEAT} = \frac{a_{wis}}{a_{wip}} \quad i = x, y, z$$

a_{wis} = Acceleration from seat
 a_{wip} = Acceleration from the base

		During the clearance process		
machine	v in km/h	SEAT		
		KX	KY	KZ
Hydrema		0,54	2,10	0,55

Table 3: Arithmetical average values of the transmission seat factors SEAT

8. Assessment of the results

For the mine clearance device the vibrations during the clearance process are acceptable. The daily time to be invested can amount to 8 hours and more, without expecting any health damages.

In case the 8 hours should be exceeded, health damages should not be excluded.

The higher level of vibration is due to the high speed, which make the vehicle swing and reach a resonance level.

By looking at the transmission seat values in [Table 3](#), it can be determined that the seat had fewer vibrations. This was true from every measured position.

230

Koblenz, 30.10.2000

Räumzeiten/Randbedingungen bei WTD 91, Meppen

	Fa. Hydrema MCV 910
Datum	10.10.00
Beginn Uhrzeit	9.05
Räumzeit für 1. Spur [min]	30
Gesamtzeit [min]	135
Räumstrecke Länge/Breite [m]	90/10
Wetter- bedingungen	bewölkt, Nieselregen
Temperatur [°C]	12 - 14
Farbe der Minen	weiß

Räumzeiten/Randbedingungen auf StÜbPI Schmidtenhöhe Koblenz

	Fa. Hydrema MCV 910
Datum	24.10.00
Beginn Uhrzeit	13.42
Räumzeit für 1. Spur [min]	17 min 45 sek
Räumstrecke [m]	70 m
Gesamtzeit [min]	109
Räumstrecke Länge/Breite [m]	70/10
Wetter- bedingungen	bewölkt, trocken
Temperatur [°C]	16 -18
Farbe der Minen	gelb

Nivellement des Minentestfeldes

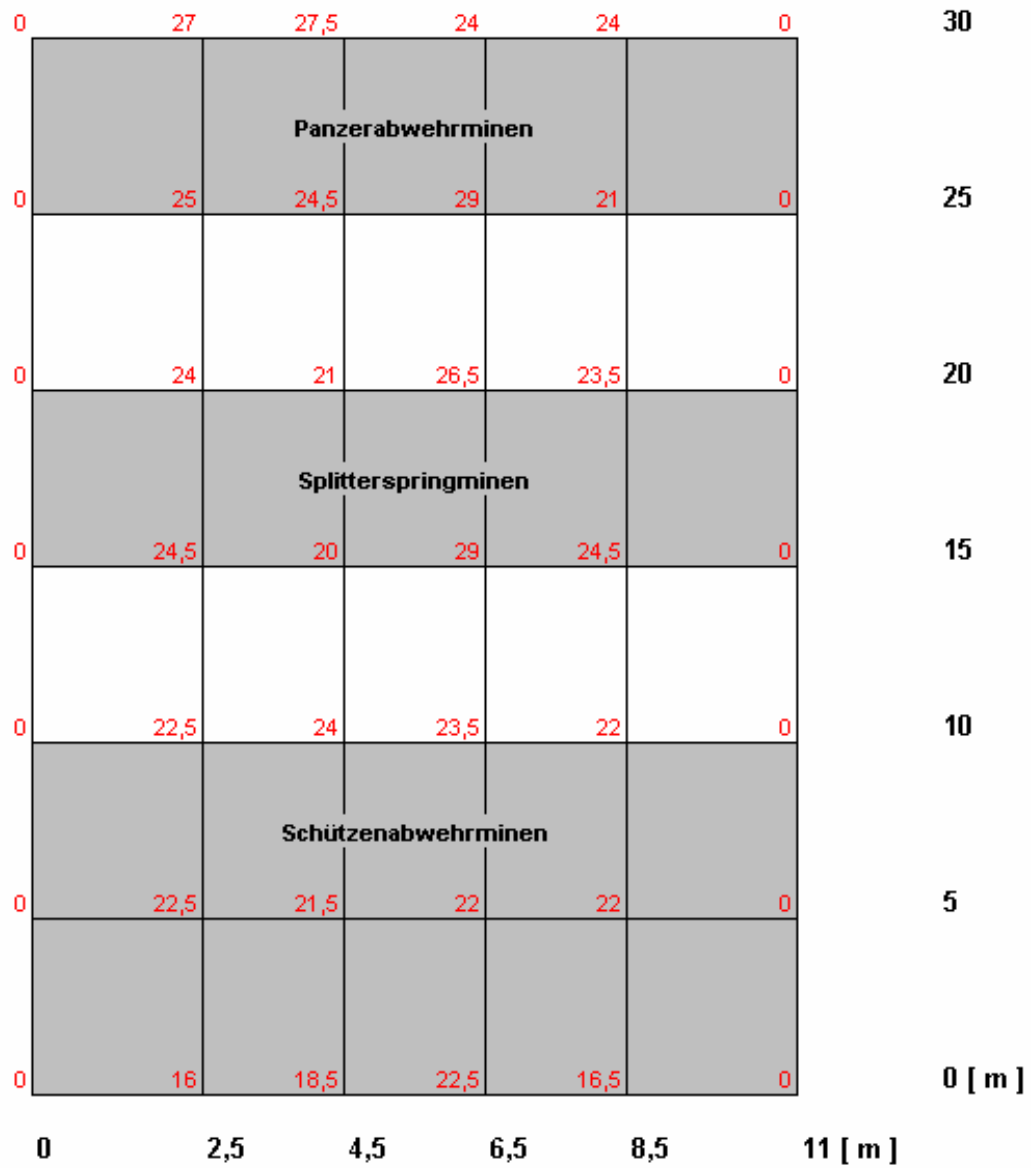

910 MCV; Fa. Hydrema





Höhenangaben in [cm]









Fahrtrichtung



WTD 51	Samples - Mine Clearance Device	Koblenz, 22.12.2000
Dept. 230		Project Nr.: 00059
TRAR Theimer	Pictures	Page 1 of 11
		Picture 1 910 MCV working position overall view, front left
		Picture 2 910 MCV working position overall view, back left
		Picture 3 910 MCV working position overall view, side left

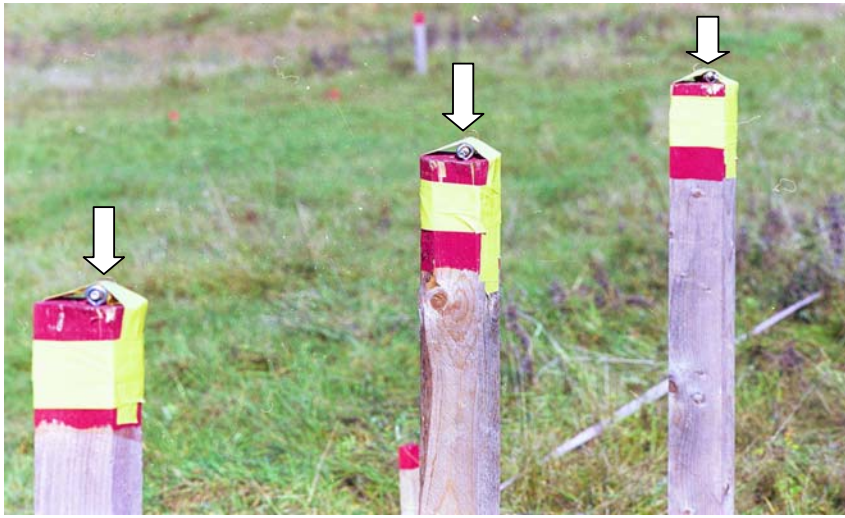

WTD 51	Samples - Mine Clearance Device	Koblenz, 22.12.2000
Dept. 230		Project Nr.: 00059
TRAR Theimer	Pictures	Page 2 of 11
		Picture 4 910 MCV during the clearance process
		Picture 5 910 MCV during the clearance process
		Picture 6 910 MCV during the clearance process



WTD 51	Samples - Mine Clearance Device	Koblenz, 22.12.2000
Dept. 230		Project Nr.: 00059
TRAR Theimer	Pictures	Page 3 of 11
		Picture 7 Moving tracks of the 910 MCV
		Picture 8 Moving tracks of the 910 MCV
		Picture 9 Moving tracks of the 910 MCV



WTD 51	Samples - Mine Clearance Device	Koblenz, 22.12.2000
Dept. 230		Project Nr.: 00059
TRAR Theimer	Pictures	Page 4 of 11
		Picture 10 910 MCV Condition of the flails after the trials on Schmidtenhöhe
		Picture 11 910 MCV Condition of the flails after the trials on Schmidtenhöhe
		Picture 12 910 MCV Condition of the vehicle after the pre-trials on WTD 91



WTD 51	Samples - Mine Clearance Device	Koblenz, 22.12.2000
Dept. 230		Project Nr.: 00059
TRAR Theimer	Picture	Page 5 of 11
 <p data-bbox="212 659 649 814"> 1 DM 31 Splitterspringmine 2 DM 21 Panzerabwehrmine 3 TM 62P3 Panzerabwehrmine 4 PPM-2 Schützenabwehrmine 5 DM 18 Schützenabwehrmine </p>		<p data-bbox="1140 302 1289 331">Picture 13</p> <p data-bbox="1140 369 1302 399">Used mines</p>
		<p data-bbox="1140 840 1289 869">Picture 14</p> <p data-bbox="1140 907 1370 970">Mine fuses MIZ DM 56 A1B1</p>
		<p data-bbox="1140 1407 1289 1436">Picture 15</p> <p data-bbox="1140 1474 1364 1537">Clearance depth measurements</p>

WTD 51	Samples - Mine Clearance Device	Koblenz, 22.12.2000
Dept. 230		Project Nr.: 00059
TRAR Theimer	Pictures	Page 6 of 11
		Picture 16 910 MCV Window alignment during the clearance process
		Picture 17 910 MCV View during the clearance process
		Picture 18 910 MCV View during front drive

WTD 51	Samples - Mine Clearance Device	Koblenz, 22.12.2000
Dept. 230		Project Nr.: 00059
TRAR Theimer	Pictures	Page 7 of 11
		Picture 19 910 MCV Dummy mines distributed on paved roads
		Picture 20 910 MCV Clearance of mines on a paved road
		Picture 21 910 MCV Clearance of mines on a paved road

WTD 51	Samples - Mine Clearance Device	Koblenz, 22.12.2000
Dept. 230		Project Nr.: 00059
TRAR Theimer	Pictures	Page 8 of 11
		Picture 22 910 MCV Mounted on a trailer
		Picture 23 910 MCV Road transport position
		Picture 24 910 MCV Loosening of the fuse of the rotating assembly

WTD 51	Samples - Mine Clearance Device	Koblenz, 22.12.2000
Dept. 230		Project Nr.: 00059
TRAR Theimer	Pictures	Page 9 of 11
		<p>Picture 25</p> <p>910 MCV To loose the screw fuse on the rear handle bar</p>
		<p>Picture 26</p> <p>910 MCV Rotation of 90° of the flail pushing frame and blade</p>
		<p>Picture 27</p> <p>910 MCV Flail pushing frame and blade flapped to the stop position</p>

WTD 51	Samples - Mine Clearance Device	Koblenz, 22.12.2000
Dept. 230		Project Nr.: 00059
TRAR Theimer	Pictures	Page 10 of 11
		<p>Picture 28</p> <p>910 MCV Flail pushing frame lowered to the clearance position</p>
		<p>Picture 29</p> <p>910 MCV Clearance position</p>
		<p>Picture 30</p> <p>Searching for remaining mine fragments with the rock collector</p>

WTD 51	Samples - Mine Clearance Device	Koblenz, 22.12.2000
Dept. 230		Project Nr.: 00059
TRAR Theimer	Pictures	Page 11 of 11
		Picture 31 Searching for remaining mine fragments with the rock collector

WEHRTECHNISCHE DIENSTSTELLE
FÜR WAFFEN UND MUNITION
WTD 91

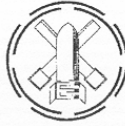

49716 Meppen; den 11.01.2001

Tel. (05931) 43 - 2360

App.:

Dezernat 360

Ausfertigung

Verteiler

1. - 8.

WTD 51 - 230

9. - 10.

WTD 91 - 360

Prüfgegenstand:

Bericht Nr.: 34/00/91-360

WTA-Nr.: E/E510/00672/Q5204

Protokoll Nr.:

Vergleichserprobung von Minenräumfräsen

Aufgabe:

Vorbereitung und Bewertung der Räumergebnisse
an Panzer- und Schützenminen

Result (summarised version):

In Meppen the large AT-mines were cleared by the mine clearance device in object. at 100% Most of them initiated during the clearance process.

The AP-fragmentation mines with tripwire were all initiated, whereas through the pressure fuse only half of them were initiated. The remaining mines were made harmless by destruction of the fuse.

For the small AP-mines, once 100% of clearance success was once reached, through initiation, and once 95% of clearance success with 90% of initiations.

In Koblenz the soil had a higher clay content. The evidence of the clearance success for the AP-mines was otherwise even better.

Key words: **Mine clearance devices, AT-mines, AP-mines, blast surrogate mines, clearance success.**

Königstein
Königstein

1	Background:	
2	Preparation of the test fields:	2
3	Preparation of the mines:	2
3.1	Blast surrogate mines for Meppen:.....	2
3.2	Inert mines for Koblenz:.....	3
4	Schedule of trials:	3
5	Mine clearance trials in Meppen:	4
5.1	Preparation of the mine test fields:	4
5.2	Clearance process conducted by Fa. Hydrema	4
5.3	Searching with mine prodder and spade:.....	5
5.4	Sieving with rock collector:	5
5.5	Single results:	5
5.6	Overview of the clearance results:	6
5.7	Results for the single mines:	7
6	Mine clearance trials in Koblenz:	7
6.1	Preparation of the test fields:.....	7
6.2	Execution of the trials:	8
6.3	Sieving with the rock collector:	8
6.4	Single results:	8
6.5	Overview of the clearance results:	9
6.6	Results for the single mines:	10
7	Clearance results for the mine clearance device:	10

Anlagen: Measurement [paper 1 - 9](#) [Single results of Meppen for Fa. Hydrema](#)
Measurement [paper 10 - 13](#) [Single results of Koblenz for Fa. Hydrema](#)

1 Background:

The WTD 51 – 230 had the task to execute comparative trials of up to 5 different mine clearance devices at two different places with different soil characteristics.

WTD 91- 410 was supposed to choose the terrain in Meppen, to prepare it, to measure it and to follow up the trial.

WTD 91 – 360 had to make available in Meppen partially loaded blast surrogate mines, to prepare them and to evaluate the clearance success on the basis of the uncleared mines and mine fragments found.

For Koblenz inert mines should be prepared to be used in the same mine fields and to be evaluated later on.

2 Preparation of the test fields:

The distribution plan of the AP-mines and the AT-mines was re-elaborated several times and finally used according to the WTD 51 – 230 report.

After the start-up section, 2 different AP-mines were encountered. In Meppen 20 DM11 and 15 PPM-2 mines were deployed. These mines contained only the detonators. (In Koblenz due to restricted availability only 14 + 14 AP-mines could be used).

After that 5 MIZ DM56 A1B1 of the AP-fragmentation mine DM31 followed, which were fixed to wooden sticks and connected with tripwires. All the wooden sticks and the tripwires were collected after the first clearance action. (In Koblenz, only 3 MIZ from each were bound to wooden sticks.)

The 5 AP-fragmentation mines DM31 were buried at slightly varying depths. Their MIZ DM56 A1B1 had to be set off without tripwires, as pressure fuses. These mines contained only the initiation charge.

Later on, 2 series of AT-mines followed, 5 DM21 and 5 TM-62 P3, which had been buried at varying depths up to 20 cm. The DM21 contained the fuse and 100g of black powder explosive charge. The TM-62 P3 contained the whole fuse with about 10g of extra charge.

3 Preparation of the mines:

3.1 Blast surrogate mines used in Meppen:

	<u>prepared</u>	<u>used</u>	<u>remaining</u>
AP-mines DM11 Lot DN-113 Explosive body replaced by wax Detonator about 0,1 g screwed in	79	60	19
AP-mines PPM-2 Lot 06-06-76 and 06-30-77 Explosive body taken out Detonator, about 1 g employed	60	45	15
AP-fragmentation mines DM31 Explosive body inert filled	20	15	5

S.P.-propelling charge (about 100g) MIZ DM56 A1B1 lot RM-3-81 A			
AT-mine DM21 No explosive body S.P.-explosive black powder charge (about 100g) MIZ DM1001 with fuse chain from the lot DIN 1-4 lot	20	15	5
AT-mine TM 62 P3 Lot 06-26-89 No explosive body MIZ MWD-62 loaded (about 10g)	20	15	5

3.2 Inert mines used in Koblenz:

	<u>prepared</u>	<u>used</u>	<u>remaining</u>
AP-mines (EX) DM18 Without smoke charge	59	42	17
AP-mines PPM-2 Completely emptied	59	42	17
AP-fragmentation mines DM31 No explosive charge With inert MIZ DM56 A1B1	20	15	5
AT-mine DM21 No explosive charge With inert MIZ DM1001	20	15	5
AT-mine TM 62 P3 No explosive charge With inert MIX MWD-62	20	15	5

4 Schedule of trials:

10.05.02	Pre-discussion with WTD 51 - 230 with the Meppen contractor WTD 91 - 410.
12.07.00	Selection of the Russian mines according to their availability.
21.07.00	Assignment of partial contract 00672/703.
14.08.00	Start of work on blast surrogate mines DM21.
05.09.00	Discussion with WTD 51 - 230 and demonstration of the 5 different blast surrogate mines.
13.09.00	Unlocking time test of the SchMi PPM-2.
04.10.00	Distribution of blast surrogate mines in Meppen.

10.10.00	Clearance process with 910 MCV, Fa. Hydrema
18.10.00	Search of the sandy, grass-moss and mixed soil with wheeled loader and rock collector.
01.11.00	Photographing mine fragments in the 3 mine fields in Meppen.
07.11.00	Survey and assessment together with a representative of the army.
28.09.00	Transportation of the inert mines to Koblenz.
13.10.00	Distribution of the inert mines on Schmidtenhöhe in Koblenz was finished.
24.10.00	First clearance process done with 910 MCV, Fa. Hydrema
23.11.00	Mission to Koblenz-Rübenach for the survey of the mine fragments from the three mine test fields from Koblenz-Schmidtenhöhe.
24.11.00	Assessment and photographing of the mine fragments in the presence of a representative of the army were taken.

5 Mine clearance trials in Meppen:

5.1 Preparation of the mine test fields:

The test fields had been measured and marked in September 2000 on the grass-moss vegetation ground in front of the horseshoe bank.

On 04.10.00, blast surrogate mines were distributed by the Dept. 360 in the mine field, more precisely, 35 small AP-mines, 5 AP-fragmentation mines and 10 AT-mines. These mines were all armed at the moment of deployment due to time needed for activation, especially the AP-mines PPM-2. .

On 09.10.00, 5 MIZ DM 56 A1B1 fuses were mounted on wooden sticks with tripwires.

These 5 fuses and the 5 MIZ, which had been installed as pressure fuses on DM31 mines, were armed immediately before the clearance trial.

5.2 Clearance process by Fa. Hydrema

On 10.10.00 in the morning the 910 MCV of the Fa. Hydrema cleared the third mine field (white colour). The vehicle moved backwards, and threw the flailed soil and the findings back towards a big protection blade, which deposited the ejected ground 2-3 m further down. To avoid leaving untouched soil behind, the vehicle made slight zigzag movements. Fa. Hydrema was in this way able to flail the established terrain in a timeframe of 2 hours, by driving over it 5 times. The timeframe was considered quite long but the results seemed to be very good.

The explosions of the mines caused no visible movement of the ground, whereas most of the explosions of the small AP-mines could be heard.

For details see [Paper 1 + 2](#).

For the AP-fragmentation mines DM31 only one explosion was heard, whereas another mine was found lying next to the mine field with a squashed fuse.

From the 10 AT-mines, 10 explosions were heard, therefore all were cleared through initiation.

5.3 Searching with mine prodders and spade:

On 16.10.00, the mine field (Hydrema) was searched with mine prodders, spade and rock collector.

On the 3rd mine field (Hydrema) all 4 AT mines DM21 were found and dug out. They only showed slight damage.

On 17.10.00, the prodder was used to look for AP-fragmentation mines and AT-mines and not the rock collector. Nothing was found.

After deployment of the rock collector, all the soil that had been moved and taken away was levelled. By doing so fragments of PPM-2 and TM-62 P3 were found.

5.4 Sieving with the rock collector:

On 16.10.00 the company Hoogen came with a field tractor and rock collector Grimme CS1700. In the beginning the system seemed to work fine, but a large amount of sand was generated in front of the vehicle very soon, which did not allow the sieving part to work and which made the tractor stop several times. Apparently, the problem was that the penetrated grass-moss branches prevented the sand from circulating. The vehicle was anyway able to detect a DM31 with broken fuse and a deactivated MIZ DM56 A1B1.

The attempt to increase the traction force of the tractor using a tank recovery vehicle ended up in a larger amount of sand, and did not solve the problem.

In the end a wheeled loader to excavate the sand and pour it into the operating rock collector was employed. After 4 half filled shovels, the rock collector emptied its bucket and moved forward over the sand heap for about 5 m to restart the loading process. The output was finally combed with the fingers.

The third mine field was re-levelled on 18.10.00 before the digging process, whereby three mine cases of exploded AT-mines were found:

1x DM21

1x TM-62 (still in good shape)

1x TM-62 (empty and green plastic case)

During the sieving process a single plate spring with needle from the AP-mine DM 11 was found, which had not initiated.

5.5 Single results:

Comments on the initiations heard, the recovered mines and the mine fragments found with the rock collector in the Meppen mine field, are given in:

Measurement [paper 1 - 9](#) for field 3 „910 MCV“ of Fa. Hydrema

The first two measurement papers summarise the visible and heard results during the clearance process. After that, 3 measurement papers on the outcome of the results in the single mine field sections follow, that is, in the AP-mines, AP-fragmentation mines and AT-mines sections.

4 pictures are included showing an overview of the field, showing also the single field sections, that is, the AP-mines, AP-fragmentation mines and AT-mines sections, and a zoom of some specific parts (especially of APM DM11) follow.

Note that, (as it is visible on the pictures of field 3) an AP-fragmentation mine DM31 is missing. The missing mine case with broken fuse in field 3 was already collected on 10.10.00 and put with the other inert mines DM31.

5.6 Overview of the clearance results:

On 09.10.00 during clearance trials with the 910 MCV, in Meppen in a test field distributed with blast surrogate mines.

Mine	Vehicle	Field 3 Fa. Hydrema 910 MCV
TM-62		5 initiated (4 x fragmented) (1 x mine body intact)
DM21		5 initiated (5 x mine body intact)
DM31		1 x initiated 4 x cut off } 5
MIZ		5 initiated
PPM-2		(15 heard) * 15 Rings found (lots of fragments) * estimation
DM11		(16 heard) * 19 cases found 1 upper part case 1 Needle * Estimation

5.7 Results for the single mines:

ATMTM-62	5 x Clearance success = 100 %
ATM DM 21	5 x Clearance success = 100 %
AP-fragmentation mine DM31	5 x Clearance success = 100 %
MIZ DM56 A1B1	5 x Clearance success = 100 %
APM PPM-2	Presumably all were initiated, but due to the large amount of sand they were not heard and during the sieving process very few pieces were found (a lot of case fragments were found).
APM DM11	Almost all were found in an almost complete condition (only few case fragments were found).

The AT-mines were cleared to 100%, whereby all of them exploded.

The AP-fragmentation mines were also cleared up to 100%. Through the pull initiated fuse almost all exploded, whereas through the pressure fuse half of them were made harmless, since their fuses were broken off.

For the Hydrema-flail 31 initiations of the 35 distributed mines were heard. Later on 15 case rings of detonated PPM-2 were found (100%) and 19 plastic cases together with 2 untouched needles of the DM11 (95%). Presumably, the last plastic case was just not found so that we could have also in this case a clearance success equal to 100%. Most of the AP-mines exploded, but only a few were made harmless through crushing.

6 Mine clearance trials in Koblenz:

6.1 Preparation of the test fields:

In week 40/41 in 2000 the mine field was measured, marked and inert mines were placed, in order to test the mine clearance device of WTD 51-230 on the StOÜbPI Schmidtenhöhe in Koblenz.

Different from Meppen, in Koblenz only 14 +14 = 28 small AP-mines were distributed. The APM (EX) DM18 was still equipped with a dummy. The APM PPM-2 had been armed before deployment.

The AP-fragmentation mines were used with activated MIZ DM56 A1B1. The AT-mines and TM-62 P3 were buried in the ground without the safety catch.

6.2 Execution of the trials:

On 24.10.00, the “910 MCV” of Fa. Hydrema cleared the third mine test field (with the yellow coloured mines), whereby a MIZ DM56 A1B1 did not explode, and only its tripwire was cut off. For a surface of 10 x 70 m, 1 h 49 min. were needed.

6.3 Sieving with the rock collector:

In week 45-46 in 2000 the mine field on the Schmidtenhöhe was searched with the rock collector Grimme CS 1700 pulled by a tractor CASE III MX 135.

The rock collector needs, while moving forward, an inclined surface. The ground is reduced to small pieces, i.e. sieved through the 7 rotating star-shaped rubber rollers. The pieces within a diameter larger than 2,5 cm are collected in a special container.

Because the rock collector only reaches a ground penetration depth of max. 25 cm (the clearance depth of the mine clearance device amounts to 25 to 50 cm) and the traction force of the tractor was insufficient due to the soil conditions, i.e. a lot of natural vegetation (WTD 91) and high clay content, the following procedure was followed in the Schmidtenhöhe test fields.

With the tracked multi-purpose excavator, the soil was directly removed and deposited on the unflailed soil in about 1,50 m wide and 0,50 m high strips next to the mine fields. After that the soil was sieved 3 to 4 times with the rock collector. During the sieving process the container was opened and the sieved soil dropped out. Two persons, standing each at one side of the container, took out the mines and the remaining pieces. Another person walking directly in front of the rock collector sorted out the visible pieces beforehand. Due to continuous rain while working with the rock collector, the sieving part of the rock collector was constrained as a consequence of the water-logged soil. The soil would agglutinate and bigger soil lumps had to be reduced by hand. It cannot be disregarded that mine pieces were completely covered by the soil and were therefore not found.

The following surfaces were searched for mine fragments:

For the Fa. Hydrema the whole test lane up to 15 m after the end of the mine field was searched, whereby three mine pieces were already found in front of the test lane. Presumably, some had been thrown over the driver cabin. All the pieces found were destroyed. A destroyed mine was found about 2 m after the mine field, so that the search was stopped at a distance of 15 m away of the test fields.

WTD 51-230 put a lot of efforts in the search for mine fragments and very good results were achieved.

The flailing result for inert mines was completely different in the loamy ground of the Schmidtenhöhe than in the sandy soil of Meppen.

6.4 Single results:

Details about the fragments of the inert mines found in the mine field in Koblenz with the rock collector are given in:

Measurement [paper 10 - 13](#) for Field 3 „910 MCV“ of Fa. Hydrema

The measurement papers contain an overview of the mine fragments found. After that 3 pictures are given: a complete overview of the field, the AT-mines and the AP-mines.

The inert mines were not completely destroyed. For the APM DM18, 3 out of 13 found mines had still their dummy plugs. If they had had a detonator, it would probably have exploded through the strong impact. For the APM PPM-2, 5 out of 14 mines were found still in good condition. They should have probably exploded in accordance to the previous experiences.

A tripwire of a MIZ DM56 A1B1 was only cut without exploding. This is one additional possibility. This mine would in a real mine field only have been cleared when directly driving over it. The cleared bodies of the APM mines DM31 and ATM mines DM21 had only been partially damaged and were not completely crushed. The judgement of the results achieved in this mine field is still very good.

6.5 Overview of the clearance results:

In the mine field, prepared with inert mines, during the clearance trial with the 910 MCV in Koblenz on the 24.10.00.

Mine	Vehicle	Field 3 Fa. Hydrema 910 MCV
TM-62		5 failed
DM21		5 presumably detonated
DM31		5 cut
MIZ		2 initiated 1 wire cut
PPM-2		9 completely destroyed 5 presumably initiated
DM18		9 completely destroyed 1 without detonator 3 presumably initiated

6.6 Results for the single mines:

ATM TM-62	5 x clearance success = 100 %
ATM DM 21	5 x clearance success = 100 %
AP-fragmentation mine DM31	5 x clearance success = 100 %
MIZ DM56 A1B1	2 x clearance success
APM PPM-2	14 x clearance success = 100 %
APM (EX) DM18	14 x clearance success ≈ 100 %

The AT-mines have been cleared by the 910 MCV.

The AP-fragmentation mines have also been cleared.

A tripwire was detached without initiation. This means, that only the flailed surface can be defined as cleared. Next to the flailed surface, AP-fragmentation mines with pressure fuse function can be left behind.

For the small AP-mines, for the PPM-2, 100% of clearance success was reached. Following the experiences in Meppen, also in Koblenz all the PPM-2 should have been initiated. For the smallest AP-mines DM18, 100% of clearance success could not be reached, but based on the mine fragments found it can be estimated that also for the AP-mines the clearance success amounts almost to 100%.

7 Clearance results for the mine clearance device:

The mine clearance device "910MCV" of Fa. Hydrema took quite a lot of time to clear the given surface.

Anyway a clearance success of 100% could be reached. Whereby, almost all the AT-mines and AP-mines were initiated. For the AP-fragmentation mines only the pressure fuses were cut off, which represents anyway clearance success.

The clearance result of the presented machine shows that a final selection is only possible following further criteria:

- Capability to maintain working performance in difficult, rocky terrain,
- Capability to withstand 10 AP-mines initiated in the same tool position and 5 AT-mines distributed over the tool width,
- Time and costs of repairing after setting-off AT-mines,
- Purchase and maintenance costs of the machine,
- Transportation costs and possibilities.

Office	WTD 91	Dept.	360	Editor	Königstein	Date	10.10.00
	Measurement paper			Paper Nr.	1	Page total	

**Clearance trial in field 3 in Meppen
with „910 MCV“ of Fa. Hydrema
with blast surrogate mines (white)**

Distributed were:	Observed explosions during clearance process:					
	1.	2.	3.	4.	5.	Total
APM DM 11: <u>20</u> APM PPM-2: <u>15</u>	} 8 x	10 x	4 x	6 x	3 x	31 x
MIZ DM 56: <u>5</u> with tripwire	5 x					5 x
APM DM 31: <u>5</u> with pressure fuse		1 x	1 x			2 x
	↑ (was found with crushed fuse next to the field)					
ATM DM 21: <u>5</u>	2 x	1 x	1 x	1 x		5 x
ATM TM-62: <u>5</u>	1 x	1 x	1 x	1 x	1 x	5 x

Office	WTD 91	Dept	360	Editor	Königstein	Date	10.10.00
	Measurement Paper			Paper Nr.	2	Page total	

**Clearance trial on field 3 in Meppen
with „910 MCV“ of Fa. Hydrema
with blast surrogate mines (white)**

The smallest AP-mines were easily recollected, since the backward rotating flails do not cover them with earth. Both mine types could, due to the large security distance to be maintained, not any more be distinguished from the fast rotating tool.

The AP-mines DM31 were more difficult to collect, since they were thrown after their initiation thrown against the clearance blade, after which they disappeared into the ground.

During the fifth pass of the last section of 1-2 m width, still one mine casing, which had probably exploded before, flew away.

The Hydrema-machine was slow; it took 15-25 min. to clear a distance of 80 m.

Office WTD 91	Mine distribution plan AP-mines	Date 10.10.00	
Dept 360		Paper Nr 3	Page total
Editor Königstein	<input type="checkbox"/> Measurement paper	<input type="checkbox"/> Field 3 „910 MCV“ (Fa. Hydrema)	

10.10. 18.10.	<p>– 15 initiations were heard.)*</p> <p>– 15 case rings and many fragments were found.</p> <p><u>(15 x clearance success)</u></p> <p style="text-align: center;">⊗ ⊗ ⊗ ⊗ ⊗</p> <p>5 cm deep</p> <p>Due to the large security distance to be maintained the detonation noises of the AP-mines PPM-2 and DM11</p> <p style="text-align: center;">⊗ ⊗ ⊗ ⊗ ⊗</p> <p>0 cm deep</p> <p>could hardly be distinguished.</p> <p style="text-align: center;">⊗ ⊗ ⊗ ⊗ ⊗</p> <p>on top! <u>PPM-2</u></p>	
10.10. 18.10.	<p>31 explosions were heard</p> <p style="text-align: center;">○ ○ ○ ○ ○</p> <p>5 cm deep</p> <p style="text-align: center;">○ ○ ○ ○ ○</p> <p>0 cm deep</p> <p>For later evaluation see (*)</p> <p style="text-align: center;">○ ○ ○ ○ ○</p> <p>0 cm deep</p> <p style="text-align: center;">○ ○ ○ ○ ○</p> <p>on top ! DM 11</p> <p>16 initiations were heard.)*</p> <p>18 gum cases of initiated mines, 1 empty gum case+1 upper part of case + 1 needle.</p> <p>Furthermore, at least 1 mine without fuse was crushed.</p> <p><u>(19 x clearance success)</u></p>	

Office WTD 91	Mine distribution plan AP-mines	Date 10.10.00	
Dept 360		Paper Nr 4	Page total
Editor Königstein	<input type="checkbox"/> Measurement paper	<input type="checkbox"/> Field 3 „910 MCV“ (Fa. Hydrema)	

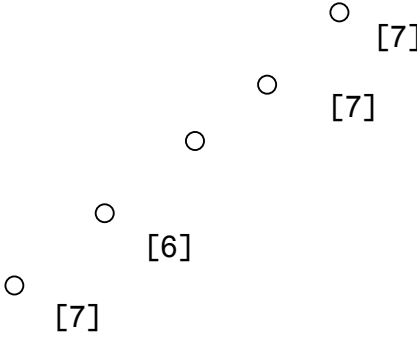
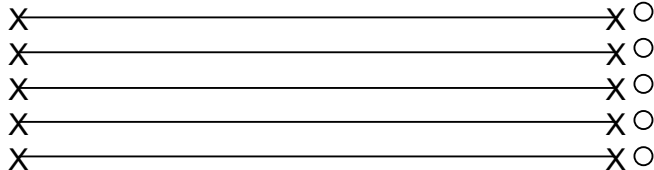
10.10.	<p>1 initiation heard. The mine casing was thrown away later on.</p> <p>1 Mine was found next to the mine field with crushed fuse [6]</p>
18.10.	<p>3 mines with broken fuses were found through the help of a probe (mines were even buried) [7] .</p>  <p style="text-align: right;">5 x <u>clearance success</u></p> <p style="text-align: right;"><u>DM 31</u> With pressure fuse</p>
10.10.	 <p style="text-align: right;"><u>MIZ DM 56 A1</u> With trip wire bound to wood</p> <p>stick</p> <p>5 MIZ were initiated at the edge of the mine clearance device over the tightly bound trip wire, and were initiated after the given time delay of 2 seconds.</p>

Office WTD 91	Mine distribution plan AP-mines	Date 10.10.00	
Dept 360		Paper Nr 5	Page total
Editor Königstein	<input type="checkbox"/> Measurement paper	<input type="checkbox"/>	Field 3 „910 MCV“ (Fa. Hydrema)

10.10.	5 initiations were heard.
18.10	(2 Mine bodies were found in the pre-programming phase, 1 was still in good condition and 1 empty plastic case was also found). <p style="text-align: center;">⊗ 0 ⊗ 5 ⊗ 10 ⊗ 15 ⊗ 20 cm deep <u>TM-62_P3</u></p>
10.10.	5 initiations 4 mine bodies were found in the same area where they had been layed. They had been only slightly damaged.) (1 Mine was found during the pre-programming phase.) <p style="text-align: center;">○ 0 ○ 5 ○ 10 ○ 15 ○ 20 cm deep <u>DM_21</u></p>









Feld 3

Hydrema

10.10.2000

Office WTD 51	Dept 230	Editor Theimer	Date 24.10.00
Measurement Paper		Paper Nr. 10	Page total

**Clearance trial in Koblenz-Schmidtenhöhe
with „910 MCV“ of Fa. Hydrema
with inert mines in field 3 (yellow)**

Distributed were:	Found remaining:	Proof
APM DM 18: <u>14</u>	13 rubber cases, of which: 9 found bodies (+) 1 without sealing plug (+) 3 still with dummy plug (?)	(13 x) (?)
SchMi PPM-2: <u>14</u>	9 upper rings + 9 O-rings + 9 case fragments (+) 5 mines were almost intact, but had been initiated(+)	<u>14 x</u>
MIZ DM 56: <u>3</u> with tripwire	2 x trip wire detonated, 1 x trip wire only detached ⊖ (this means only <u>66 % of clearance success.</u>)	(3 x)
APM DM 31: <u>5</u> with pressure fuse	5 x mines with broken fuse this means <u>100 %</u> of clearance success.	<u>(5 x)</u>
ATM DM 21: <u>5</u>	(<u>5</u> mines were damaged a lot, and had all exploded, this means <u>100 %</u> initiated).	<u>(5 x)</u>
ATM TM-62: <u>5</u>	(<u>5</u> red sealing rings (<u>5</u> needle cases + 4 rubber bellows (<u>5</u> VL-cases + 3 Detonator-cases This means <u>100 %</u> were flailed.	<u>(5 x)</u>





