

EC-I EC Motor with Integrated 4-Q Controller

Operating Instructions

Document version 1.04

Current drive firmware: EC-I: 1.20
Standard EC: 0.30

1	GENERAL INFORMATION	4
1.1	DOCUMENTS MODIFIED SCHEDULE	5
1.2	SAFETY INSTRUCTIONS	6
1.3	DEFINITION OF QUALIFIED PERSONNEL	7
2	GENERAL DRIVE SPECIFICATIONS	8
2.1	REFERENCED DOCUMENTS	8
2.2	STANDARDS AND DIRECTIVES	8
2.3	AMBIENT CONDITIONS	9
2.4	EMC	9
2.5	CONNECTIONS, INTERFACES	9
3	PARAMETER LIST	14
3.1	SYSTEM	14
3.2	DRIVE DATA	17
3.3	DRIVE MANAGER	21
3.4	PROFILE POSITION MODE	30
3.5	PROFILE VELOCITY MODE	34
3.6	POSITION CONTROL FUNCTION	36
3.7	HOMING MODE	38
3.8	VELOCITY MODE	40
3.9	MANUAL MODE	43
3.10	TORQUE PROFILE	44
3.11	ENCODER	45
3.12	CONTROL	48
3.13	POWER	51
3.14	INPUT OUTPUT	57
3.15	CAN OPEN	60
3.16	MEMORY	62
4	SPECIAL FUNCTIONS, SETTING HINTS	66
4.1	USE OF HALL SENSORS	66
4.2	ADAPTIVE CONTROLLER TUNING	66
4.3	ACTIVE BRAKING	66
5	PARAMETER TABLE	68
6	FAULT LIST	73

LIST OF FIGURES

Figure 1: Bloc diagram 12-001-014-01	9
Figure 2: Bloc diagram 12-001-014-02	10
Figure 3: Connection of RS232 interface	12
Figure 4. Relationship between speed and torque constant	20
Figure 5: Positioning procedure (control and status bits)	32
Figure 6: Partitioning of the positioning window	37
Figure 7: Drive temperature curve as a function of time	54
Figure 8: Braking example.....	67

LIST OF TABLES

Table 1: Referenced documents	8
Table 2: PIN configuration 17-pin Sub-D connector, power contacts	10
Table 3: PIN configuration 17-pin Sub-D connector, signal contacts.....	12
Table 4: PIN configuration of 9-pin Sub-D connector at PC.....	12
Table 5: PIN configuration of 5-pin M12 connector at PC	13

1 General Information

Thank you very much for purchasing this drive. Please be aware:

- ! The drive contains components that are susceptible to electrostatic discharge. Always obey the ESD handling instructions when handling electronic components!

1. Carefully unpack the drive and check it for signs of damage. Should you find any signs of damage or deviations from the content description, please inform the delivery agent immediately.
2. Read the operational instructions carefully and thoroughly. Ensure that all operators of the drive read these instructions carefully before putting the drive into operation.
3. Store the operating instructions at a location easily accessible to all personnel.
4. If, after reading these operating instructions, you have any remaining questions pertaining to installation, operation or maintenance, please contact our sales representatives with your queries:

Heidrive GmbH
Starenstraße 23
93309 Kelheim, GERMANY

Tel.: +49 (0)9441 707-0
Fax: +49 (0)9441 707-257
Email: info@heidrive.de
www.heidrive.de

1.1 Documents modified schedule

Version	Date	Machining method /Modified section	Reviser
1.04	24.04.2013	Changed to Heidrive	Perzl

1.2 Safety Instructions



Danger

Indicates that death or severe personal injury will result if proper precautions are not taken.



Warning

Indicates that death or severe personal injury can result if proper precautions are not taken.



Caution

Indicates that minor personal injury can result if proper precautions are not taken.



Attention

Indicates that property damage can result if proper precautions are not taken.



Danger Voltage

Adverts special hazards of electrical voltage. Indicates that death, severe or minor personal injury, property damage can result if proper precautions are not taken.



Warning

This drive operates with hazardous electrical voltages and is used as a drive for rotating mechanical components. Failure to obey these operating instructions may result in death, grievous bodily harm or considerable damage to property.



Warning

Only suitably qualified personnel are permitted to work with these devices. Personnel must be familiar with all warnings and measures given in these operating instructions pertaining to the setup and operation of this device. The safe and successful operation of this device depends largely on its correct and professional transportation, setup, operation and maintenance.



Warning

The motor controller contains capacitors that may be charged with high voltages momentarily after being turned on. While working on the device, be careful not to contact any exposed energized components. It is only safe to contact the devices once the voltage has decreased below the dangerous potential. Therefore, you must ensure that the electrically live components

are not contacted. The device remains energized even when the motor is not moving. Only qualified personnel are permitted to connect, start up and perform troubleshooting on the device. These specially trained personnel must be fully familiar with the warnings and maintenance measures as described in these operating instructions.



All connecting terminals and components may carry operating voltage. The circuit is not DC decoupled. Contacting the electronic components of the device during operation can cause electrical shocks. Lethal hazard!



Warning

Never install the devices in rooms containing or exposed to electrically conductive dust, corrosive or inflammable gases, dampness, rain or excessive heat.



Warning

The EC motor is not explosion proof!



It may only be operated at DC voltage. This voltage must correspond to the specifications given on the rating plate.



Only technicians specially qualified by Heidrive are permitted to perform repairs.



To ensure sufficient cooling, you must allow for free space above and below the drive for the cooling inlet and outlet. The ambient air temperature must not exceed 40 °C.



Avoid exposing the drive to excessive vibrations and/or jolting.



The drive must be connected as given in the wiring schematic. Faulty connections may destroy the device.

1.3 Definition of qualified personnel

As pertains to these operating instructions and warnings on the device itself, qualified personnel are those responsible for setting up, assembling, commissioning and operating the device and who have suitable qualifications such as:

- a) Training and instruction and/or authorization in the activation/deactivation, grounding and designation of electrical circuits and devices in compliance with pertinent safety standards.
- b) Received instruction or training in the care and use of safety equipment as stipulated by safety standards and directives.
- c) Received training in first aid.

2 General Drive Specifications

2.1 Referenced Documents

This current document makes reference to the following documents:

Reference	Document title
[1]	CiA Standard Proposal DSP-402, CANopen Device Profile for Drives and Motion Control, version 2.0, July 2002, CAN in Automation e.V.

Table 1: Referenced documents

2.2 Standards and Directives

The drive fulfills the following standards and directives:

Mech. loading

Vibration stress	10Hz–500Hz, 20 cycles per axis, 3 axes, 50m/s ² , 0.075 mm
Bump forces	2000 bumps per axis, 3 axes with half-sine bumps at 150m/s ² , 6ms ²

EMC

Transient emissions	EN61000-6-4	A (industry)
Immunity to interference	EN61000-6-2	
Interference immunity against contact discharge	EN61000-4-2	±4kV
Interference immunity against air discharge	EN61000-4-2	±8kV
Immunity to electromagnetic interference fields	EN61000-4-3	10V/m
Power burst immunity test	EN61000-4-4	±2kV
Signal burst immunity test	EN61000-4-4	±1kV
Power surge test	EN61000-4-5	±0.5kV
Signal surge test	EN61000-4-5	±1kV
Immunity against electrically conducted interference	EN61000-4-6	10V, 80% AM
Magnetic field	EN61000-4-8	30A/m
Overtoltage category	VDE 0100	2

2.3 Ambient Conditions

Ambient temperature of drive with integrated electronics	0-40 C (not condensation)
Storage temperature	-40 C – +70 C
Air humidity	15 – 85%
Enclosure type	IP54
Installation level	<1000m above sea level

2.4 EMC

The drive fulfills the stipulated EMC requirements without need for further measures. All cables must be shielded.

2.5 Connections, Interfaces

2.5.1 Wiring Schematic

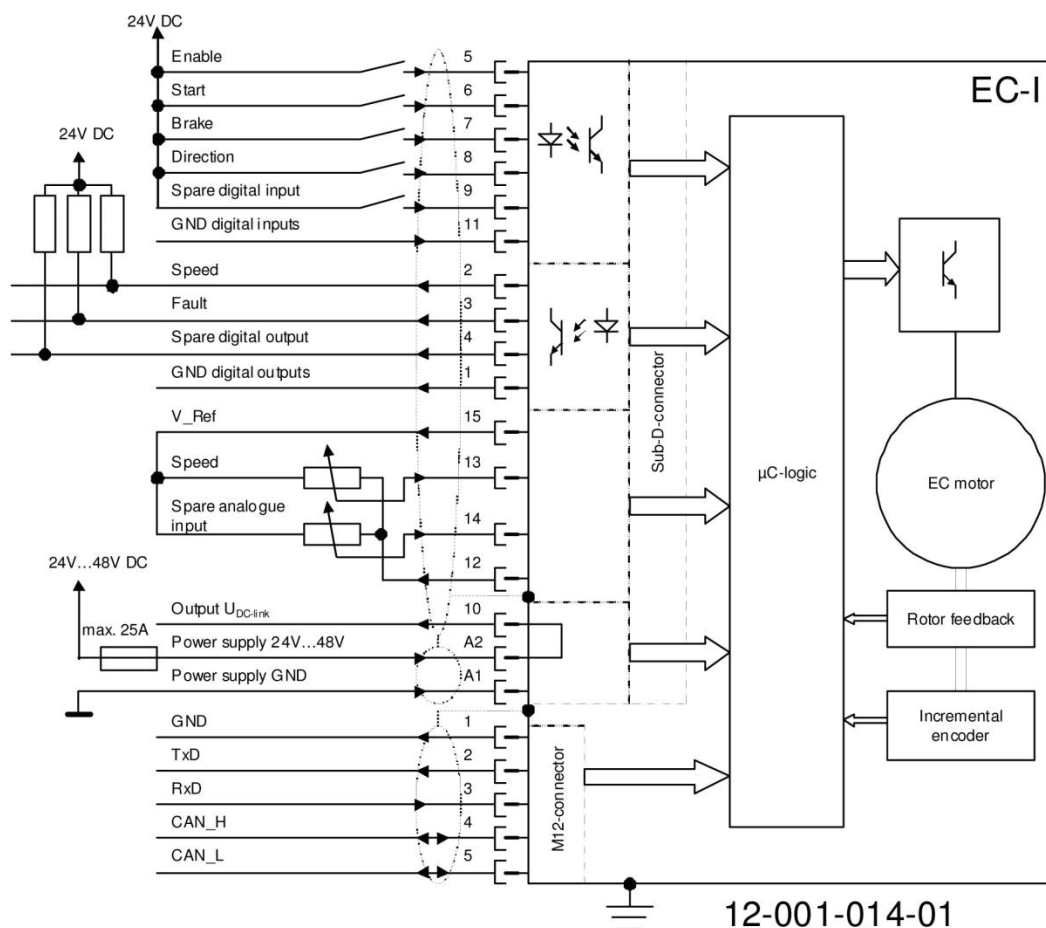

Figure 1: Bloc Diagramm 12-001-014-01

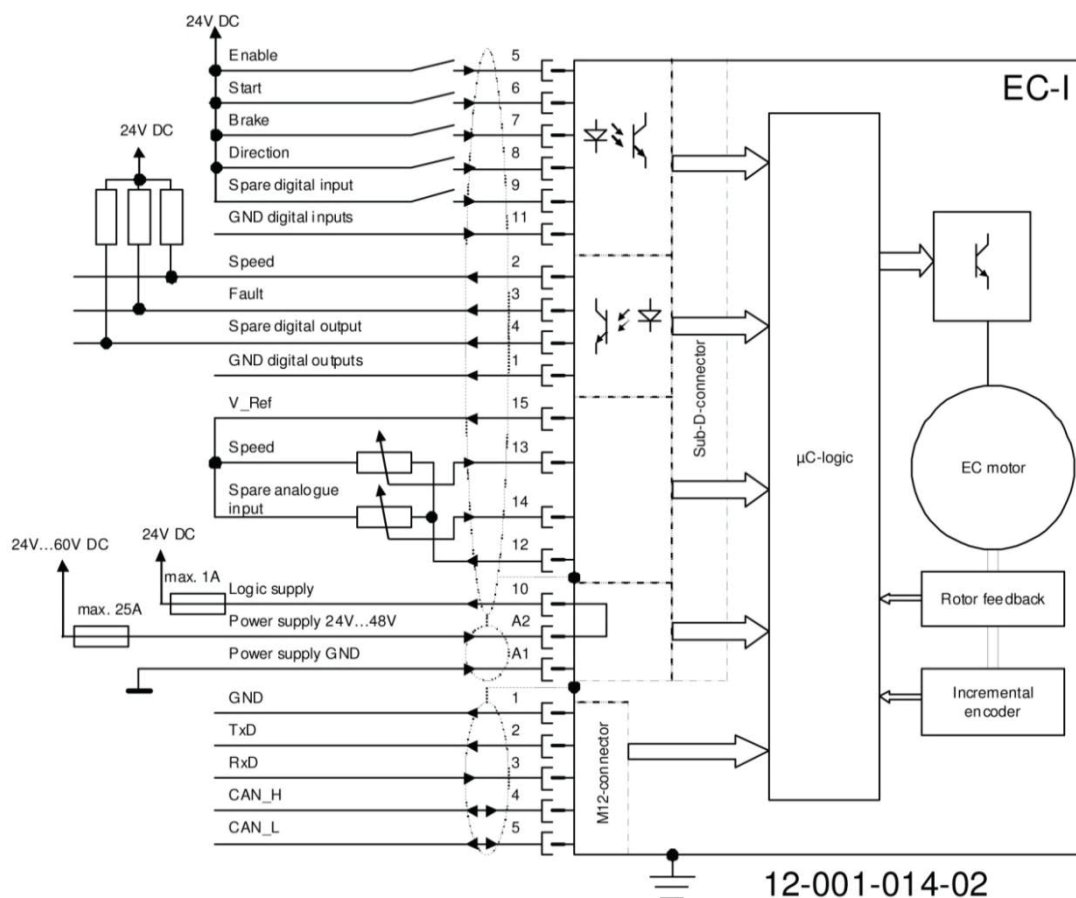

Figure 2: Bloc diagram 12-001-014-02

2.5.2 Electrical Ratings

Power-supply voltage, 12-001-014-01	24V to 48V DC $\pm 10\%$ incl. ripple
Power-supply voltage, 12-001-014-02	24V to 60V DC $\pm 10\%$ incl. ripple
Logic-supply voltage, 12-001-014-02	24V to 48V DC $\pm 10\%$ incl. ripple
Power frequency	DC, ripple 0–400Hz
Output voltage EC motor	0–95% U_{zk}
Peak output current per phase in EC motor	$\leq 30A$
Continuous output current per phase in EC motor	$\leq 15A$
Output frequency of EC motor	0–133 Hz
Clock rate of EC motor	4–16 kHz (configurable)

2.5.3 Power Supply

Pin	Abbreviated designation	Designation
A1	DC_GND	Power supply GND
A2	DC_PLUS	Power supply PLUS

Table 2: PIN configuration 17-pin Sub-D connector, power contacts

2.5.4 Inputs

Name	Type	Level inactive	Level active	Input current
Start	Digital optical isolation	0–6V DC	15V–24 V DC	≤1mA
Brake				
Direction of rotation				
Controller enable				
Spare input				

Name	Type	Minimum	Maximum	Input current
Set point speed	Analogue	0V DC	10V DC	≤1mA
Spare				

All analogue inputs are captured by the processor's internal AD converter at a resolution of 10 bits.

2.5.5 Over temperature

One internal digital input (not electrically isolated) is dedicated for an isolated temperature switch that opens when coil temperature exceeds permissible limit.

2.5.6 Outputs

External pull-up resistor required, supply voltage (U_{pu}) of resistor ≤ $U_{DC \text{ link}}$.

Name	Type	Level inactive	Level active	Output current
Speed	Digital, open collector, optically isolated	$U_{pu} \dots U_{pu} - 5V$	<1V DC	≤20mA
Fault				
Spare digital output				
$U_{DC \text{ link}}$ (12-001-014-01)	Supply Voltage		$U_{DC \text{ link}}$	≤100mA
V_ref	Reference voltage		10V DC	≤10mA

Pin	Abbreviation	Designation
1	GND_OUT	Common ground outputs
2	RPM_OUT	Speed output
3	ERR_OUT	Fault output
4	RES3_OUT	Spare digital output
5	Enable	Input for controller enable
6	START	Input for motor start
7	BRAKE	Input for motor brake
8	LR_IN	Input for direction of rotation
9	RES1_IN	Spare digital input
10	U _{ZK}	U _{ZK} output
10		Logic-supply input 24V, 12-001-014-02
11	DIGIN_GND	Common ground digital inputs
12	ANIN_GND	Common ground analogue inputs
13	RPM_W	Speed set point
14	RES2_IN	Spare analogue input
15	V_ref	Analogue 10V output

Table 3: PIN configuration 17-pin Sub-D connector, signal contacts

2.5.7 Interfaces

The two available interfaces (CANopen and RS232) are connected to the drive using a common M12 plug. Both interfaces can be used simultaneously and both interfaces have the same priority.

2.5.7.1 RS232

This interface uses standard RS232 levels and only serves as a connection to the Heidrive Application Tool, a "WIN 98/NT/XP" program that allows software updates as well as configuration. Only RxD, TxD and GND are used.

The RS232 interface is not bus-capable, i.e., only one drive can be connected at a time to the PC.

The interface is not electrically isolated.

Pin	Abbreviated designation	Designation
2	TxD	Transmit data
3	RxD	Receive data
5	GND	Ground

Table 4: PIN configuration of 9-pin Subconnector at PC

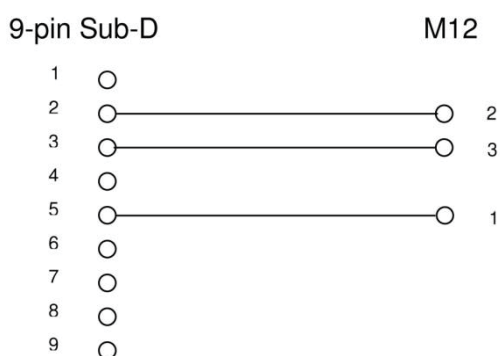

Figure 3: Connection of RS232 interface

2.5.7.2 Field Bus

An integrated CAN interface operating with CANopen protocol is used as a field bus. Physically, this corresponds to an ISO 11898 interface without electrical isolation. A MCP2551 module is used as a transceiver.

Baudrate	Permissible cable lengths
For 1MBaud	≤25m
For 500kBaud	≤100m
For 100kBaud	≤600m
For 10kBaud	≤5000m

These use 5 pin CAN field bus connectors.

	Dominant	Recessive
Sender		
CAN_H voltage	2.75V – 4.5V	2.0V – 3.0V
CAN_L voltage	0.5V – 2.25V	2.0V – 3.0V
Differential level	1.5V – 3V	-0.5V – 0.05V
Output current CAN_H	≥40mA	
Output current CAN_L	≤40mA	
Receiver		
Differential level	0.9V – 5V	-1V – 0.5V
Hysteresis	≤200mV	

Pin	Abbreviated designation	Designation
1	CAN_SHLD	Shield for CAN cable, RS232 GND
2	TxD	Transmit data
3	RxD	Receive data
4	CAN_H	Data line, dominant high
5	CAN_L	Data line, dominant low

Table 5: PIN configuration of 5-pin M12 connector at PC

The bus connection must be terminated.

3 Parameter List

3.1 System

3.1.1 Function

The System module processes general system functions.

3.1.2 Parameter List

3.1.2.1 SYS Version

ID	Index	CAN ID	CAN index	Definition
1	0	100A 2002 2003	0 0 0	Software version
1	1			Parameter version
1	2			Telegram version
1	3			CANopen version

The current version numbers are given

3.1.2.2 SYS Build Date

ID	Index	CAN ID	CAN index	Definition
2				Date

Creation date of system software

3.1.2.3 SYS Cycle Times

ID	Index	CAN ID	CAN index	Definition
3	0			PWM frequency (4kHz to 32kHz)
3	1			Frequency of current controller (1kHz to 16kHz)
3	2			Frequency of speed and position controller (0.1, 0.5, 1 and 2 kHz)

You can set the sampling times of the modules. The settings are made in steps of 4, 8, 16, 32 kHz. Changes may only be made when the drive is shut down.

Obey the following:

PWM frequency \geq current controller frequency \geq position controller frequency

3.1.2.4 SYS Storage

ID	Index	CAN ID	CAN index	Definition
4	0-3			Memory cell address

Each memory cell in the address range of the processor can be evaluated.

The output format can be set by entering the following values:

Value	Description
-4	32 bits signed
-2	16 bits signed
-1	8 bits signed
1	8 bits unsigned
2	16 bits unsigned
4	32 bits unsigned

3.1.2.5 SYS Key Word

ID	Index	CAN ID	CAN index	Definition
5				

Value	Description
91196599	Test mode 0
32168421	Test mode 1
9441707	User password
	Manufacturer password level 1
	Manufacturer password level 2

The drive offers various test modes. To activate these, you must enter the corresponding value in the Key Word parameter.

The key word is referenced at the appropriate locations.

3.1.2.6 SYS Load

ID	Index	CAN ID	CAN index	Definition
6	0			System stack
6	1			User stack
6	2			Process signals
6	3			Memory allocation

Display of actual system load. A value of 100% corresponds to maximum load.

3.1.2.7 SYS Last Reset

ID	Index	CAN ID	CAN index	Definition
7				Type of reset

Bit	Value	Definition
0	0x01	Watchdog reset
1	0x02	Software reset - Can be initiated by update. - Can be initiated by writing this parameter (password required)
2	0x04	Hardware reset after turning on voltage
3	0x08	
4	0x10	Update has initiated reset. This bit is also set to bit 1.
8	0x100	Due to CPU stepping, 2 Flash wait states have been programmed (< BA)
12	0x1000	This bit is set when the parameter is written. This allows you to check whether a reset has occurred.

The parameter displays the cause of the last reset.

Writing the value 0xaffe to the parameter initiates a reset. As an additional security feature, test mode 1 also has to be set in the SYS Key Word parameter.

3.1.2.8 SYS Ser. Baudrate

ID	Index	CAN ID	CAN index	Definition
8				Baudrate

This is where you set the baudrate for communication with the Heidrive Application Tool (HAT). After changing the baudrate, the drive responds at the previous baudrate and switches to the next value. Finally, the baudrate has to be changed by HAT.

For standard applications, the baudrate is set to 115,200 baud.

If the baudrate is changed in HAT, the baudrate of the drive is automatically changed, too. Both components can communicate with each other immediately.

3.1.2.9 SYS Name

ID	Index	CAN ID	CAN index	Definition
9				Software name

3.2 Drive data

This module returns the manufacturer's data for the drive.

3.2.1 Function

The drive manufacturer specifies this data for the motor. This data is stored in ROM.

3.2.2 Parameter List

3.2.2.1 DDA Device Name

ID	Index	CAN ID	CAN index	Definition
20		1008	0	Product name of drive

3.2.2.2 DDA Serial No. Electronic

ID	Index	CAN ID	CAN index	Definition
21		2100	0	Serial number of drive electronics

3.2.2.3 DDA Serial No. Drive

ID	Index	CAN ID	CAN index	Definition
22		1018	4	Serial number of motor

3.2.2.4 DDA Product Code

ID	Index	CAN ID	CAN index	Definition
23		1018	2	Motor product number

3.2.2.5 DDA Drive HW Version

ID	Index	CAN ID	CAN index	Definition
24		1009 2000	0 0	Version number of drive electronics, 12-001-014-02 > 2.00

3.2.2.6 DDA Motor HW Version

ID	Index	CAN ID	CAN index	Definition
25		2001	0	Version number of motor

3.2.2.7 DDA Nominal Speed

ID	Index	CAN ID	CAN index	Definition
26		6410	1	Nominal speed

3.2.2.8 DDA Nominal Voltage

ID	Index	CAN ID	CAN index	Definition
27		6410	2	Nominal voltage

3.2.2.9 DDA Nom. Motor Current

ID	Index	CAN ID	CAN index	Definition
28		6075 6410	0 3	Nominal current

3.2.2.10 DDA Max Motor Current

ID	Index	CAN ID	CAN index	Definition
29		6410	4	Maximum permissible motor current

3.2.2.11 DDA Max Drive Current

ID	Index	CAN ID	CAN index	Definition
30		6510	1	Maximum permissible drive current

3.2.2.12 DDA Nominal Torque

ID	Index	CAN ID	CAN index	Definition
31		6076	0	Nominal torque

3.2.2.13 DDA Min/Max Voltage

ID	Index	CAN ID	CAN index	Definition
32	0	6410	6	Minimum voltage $U_{DC \text{ link}}$
32	1	6410	7	Maximum voltage $U_{DC \text{ link}}$
32	2	6410	8	Maximum voltage logic-supply
32	4	6410	9	Maximum voltage logic-supply

Specification of minimum and maximum supply voltage. If the supply voltage goes beyond these limits, a fault is issued.

The minimum voltage must not exceed the nominal voltage for the DDA Nominal Voltage parameter.

The maximum voltage must not be smaller than the nominal voltage for the DDA Nominal Voltage parameter.

If both values are set to the nominal voltage, this effectively disables monitoring of the DC link voltage.

3.2.2.14 DDA Motor Calibration Date (String)

ID	Index	CAN ID	CAN index	Definition
33				Motor calibration date

This is the motor calibration date as a string parameter.

Your Heidrive Application Tool can write the parameter automatically under "Tools => motor calibration data". The value is transferred simultaneously to parameter 34.

3.2.2.15 DDA Motor Calibration Date (TIME_OF_DAY)

ID	Index	CAN ID	CAN index	Definition
34	0	6406	0	Motor calibration date, time in ms after midnight
34	1	6406	0	Motor calibration date, days since 1/1/1984

Motor calibration date in CAN format TIME_OF_DAY.

3.2.2.16 DDA Torque Constant

ID	Index	CAN ID	CAN index	Definition
35		6410	5	Torque constant of motor

Specifies the torque constant of the motor. This value is given in Ncm/A.

3.2.2.17 DDA Loss Speed

ID	Index	CAN ID	CAN index	Definition
36	0			Speed losses in motor
36	1			Speed losses in motor
36	2			Speed losses in motor
36	3			Speed losses in motor
36	4			Speed losses in motor
36	5			Speed losses in motor

Together with the DDA Loss Current parameter, this specifies the motor loss characteristic curve. Depending on the speed, the torque controller calculates the loss current according to the configured characteristic curve. Since this current is not used for generating torque, the motor current is increased by this value. This compensates for motor losses.

Together, the two motor loss parameters form a table that can be used to configure the motor losses as a function of speed. Linear interpolation is applied between table values. It is important to enter increasing speed values starting from index 0. Once a decreasing or constant speed value is detected, the table is no longer evaluated and the last current value is used from that point on. To deactivate loss compensation, only index 0 of the speed value has to be set to 5000 rpm and the current in index 0 has to be set to 0 A.

Motor loss values in braking condition are stored in parameter DDA Loss Current Brake. Negative values reduce the target value the represent the conditions of braking.

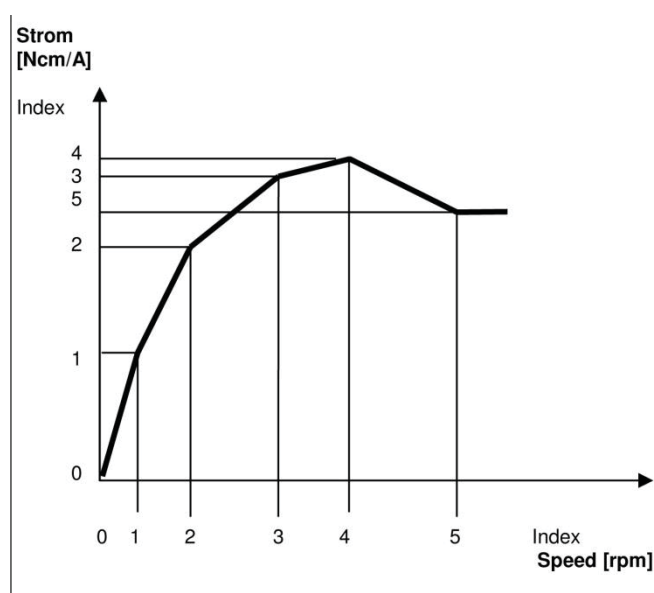

Figure 4. Relationship between speed and torque constant

As shown in figure 4, the values above the limit speed are constantly continued. For speeds lower than the one in index 0, the current from index 0 is used.

The curve shown in figure 4 can also be generated by slowly speeding up the motor without an acceleration torque.

3.2.2.18 DDA Loss Current

ID	Index	CAN ID	CAN index	Definition
37	0			Motor current losses
37	1			Motor current losses
37	2			Motor current losses
37	3			Motor current losses
37	4			Motor current losses
37	5			Motor current losses

Together with the DDA Loss Speed parameter, this specifies the motor loss characteristic curve. For more information, refer to the Data Loss Speed parameter.

3.3 Drive Manager

3.3.1 Function

The "Device Control" functionality of the DSP402 [1] is used. For more details, refer to the documentation of this component.

The finite state machine has the following states:

No.	State	Description
0	Not Ready To Switch On	Initialization
1	Switch On Disabled	Not enabled and cannot be switched on
2	Ready To Switch On	Enabled and can be switched on
3	Switched On	Switched on but set points are not being processed
4	Operation	Switched on and set points are being processed
5	Quick Stop	Switched on and fast stop
6	Fault Reaction	Fault is being processed
7	Fault	Fault has occurred

3.3.2 Parameter List

3.3.2.1 DRV Control Word

ID	Index	CAN ID	CAN index	Definition
50		6040	0	Control Word

B															
15	14	13	12	11	10	9	8	7	6	5	4	3	2	1	0
							Stop	Fault Reset	Depends on profile			Enable Operation	Quick Stop	Enable Voltage	Switch On

The Control Word is an essential parameter for controlling the drive. Its function is described in DSP402 [1].

Using sequence 0x06, 0x07, 0x0f, the drive can be set from the "Switch On Disabled (1)" state to the "Operation Enable (4)" state. Depending on the operating mode it may be necessary to set additional bits in the control word.

Using the 0x80 command, you can convert the drive from fault status (7) to the "Switch On Disabled (1)" status. This fault reset is also used when the drive is not switched on (state 1 and 2). Using this command, all warnings are deleted.

The Quick Stop bit must be set to normal mode. If it is deleted but the Bit Enable Voltage bit remains set, the Quick Stop function of the selected profile (operating mode) will be enabled. In general, a stop is executed, the drive is set automatically to state 1 (Switch On Disabled) and the drive is shut down.

The input into the control word is only effective when it differs from the current value. For instance, two successive fault resets will thus have no effect.

In "Manual Mode", this parameter is written internally and therefore cannot be changed.

3.3.2.2 DRV Status Word

ID	Index	CAN ID	CAN index	Definition
51		6041	0	Status Word

Defines the status bits according to DSP402 [1] specification.

Bit	Definition	Explanation
0	READY-TO-SWITCH-ON	1: Drive is switched on or enabled
1	SWITCHED-ON	1: Drive is switched on. Drive functions are still blocked
2	OPERATION-ENABLED	1: Drive is switched on. Drive functions are enabled. Normal operating mode
3	FAULT	1: Drive is in fault status.
4	VOLTAGE-ENABLED	1: Drive is energized independently of drive status
5	QUICK-STOP	0: Fast stop is being executed
6	SWITCH-ON-DISABLED	1: Drive is in disabled state
7	WARNING	1: Drive issues warnings that do not cause faults
8		Manufacturer-specific bit is used in profiles
9	REMOTE	0: Drive is in Manual Mode (-1), Control Word, VEL Target and VEL Polarity cannot be changed
10	TARGET-REACHED	1: Profile-specific display so that target value is reached
11	INTERNAL-LIMIT-ACTIVE	1: Position value limits have been reached
12		Profile-specific bit
13		Profile-specific bit
14		Manufacturer-specific bit is used in profiles
15		Manufacturer-specific bit is used in profiles

3.3.2.3 DRV Command

ID	Index	CAN ID	CAN index	Definition
52				Current command

This parameter specifies the current command. It is generated from the control word.

Value	Command	Description
0	Shutdown	
1	Switch On	
2	Disable Voltage	
3	Quick Stop	
4	Disable Operation	
5	Enable Operation	
6	Fault Reset	

3.3.2.4 DRV State

ID	Index	CAN ID	CAN index	Definition
53				Current state

This parameter returns the current state in the state machine. See table in section 3.3.1 Function.

3.3.2.5 DRV Error Stack

ID	Index	CAN ID	CAN index	Definition
54	0-4	1003	1-5	Fault memory
54	5-9			Fault memory

Fault memory of drive. As many as 10 faults are stored. The most current fault appears in index 0.

If the drive is in a fault state, the list is deleted by a reset in parameter DRV Control Word. The fault list can also be deleted by writing a value of 0 to index 0.

For more information on the various faults, see the "Fault List" in section 6.

3.3.2.6 DRV Mode Selector

ID	Index	CAN ID	CAN index	Definition
55		6060	0	Selection of operating mode

Using this parameter, you can select the operating mode of the drive. If this selection is permissible, the required value appears in the DRV Mode Display parameter.

It is not possible to freely change the operating mode after the drive has been released. The Positioning and Homing operating modes can only be selected when the Switch On state is disabled for the drive.

Value	Operating mode	Description
-3	PWM Mode	Simply a default value for PWM
-2	Manufacturer Position Mode	Positioning
-1	Manual Mode	
1	Profile Position Mode	Positioning
2	Velocity Mode	Speed controlling
3	Profile Velocity Mode	Speed controlling
4	Torque Profile Mode	Torque controller
6	Homing	Referencing

The operating modes are described in more detail for the modules and in DSP402 [1].

3.3.2.7 DRV Mode Display

ID	Index	CAN ID	CAN index	Definition
56		6061	0	Display of selected operating mode

3.3.2.8 DRV Polarity

ID	Index	CAN ID	CAN index	Definition
57		607E	0	Setting for installation direction and/or set point direction

Value	Definition
0	Positive set points cause motor to rotate clockwise
1	Positive set points cause motor to rotate counter clockwise

This setting may be required for certain types of gearboxes or other mechanisms connected to the drive unit. This is a preset value that cannot be changed during operation.

3.3.2.9 DRV Manu. Status Register

ID	Index	CAN ID	CAN index	Definition
58		1002	0	Operating and fault messages

There are three message types:

- Info: Only for information and without effect on motor function
- Fault: Drive fault, motor is switched off and remains off until fault status is reset.
- Fatal: Hardware fault. If this fault occurs frequently, the drive must be replaced.

Bit	Value	Definition	Type
0	0x00000001		
1	0x00000002		
2	0x00000004		
3	0x00000008		
4	0x00000010		
5	0x00000020	Under voltage, power failure has occurred at HW input Input voltage was below 12 volts Drive is switched off, log book is stored	Fault
6	0x00000040	Over voltage (current analogue value)	Fault
7	0x00000080	Under voltage (current analogue value)	Fault
8	0x00000100		
9	0x00000200	Watchdog has initiated the last reset	Fatal
10	0x00000400	Class B Hardware Trap	Fatal
11	0x00000800	Class A Hardware Trap	Fatal
12	0x00001000		
13	0x00002000	EEPROM CRC Fault	Fatal
14	0x00004000	ROM Code CRC Fault	Fatal
15	0x00008000		
16	0x00010000		
17	0x00020000		
18	0x00040000		
19	0x00080000	Drive is running at current or voltage limits, see parameters POW Current Max Mot/Gen and POW Max Duty Cycle Mot/Gen	Info
20	0x00100000	Fault detected by I ² t monitoring	Fault
21	0x00200000	Current is larger than nominal current (momentary value)	Info
22	0x00400000	Fault due to excessive temperature in electronics	Fault
23	0x00800000		
24	0x01000000	Drive has been referenced	Info
25	0x02000000	Approach target position	Info
26	0x04000000	Motor turning, see parameter ENC Stagnation Limit	Info
27	0x08000000	Motor is enabled, voltage applied to motor connecting terminals	Info
28	0x10000000	Hardware input for controller enable has turned off drive	Fault
29	0x20000000		
30	0x40000000	Drive has issued warning in DRV Error Stack parameter. Warnings do not have a direct effect on the drive operation	Info
31	0x80000000	Drive has issued a fault in parameter DRV Error Stack. If the drive is in a fault state, the fault can be reset using the reset command in the DRV Command parameter.	Fault

3.3.2.10 DRV Status LEDs

ID	Index	CAN ID	CAN index	Definition
59				LED display in HAT

Bit	Colour	Definition
0	Yellow	A fault has been issued in the DRV Error Stack parameter.
1	Red	The drive is operating at its set limits. <ul style="list-style-type: none"> The set point for current is equivalent to the maximum value in the POW Current Max Mot/Gen parameter. The transistors are being driven at their set limits (POW Duty Cycle) DC link voltage is too large (POW Brake Voltage). This message is stored for 2 seconds.
2	Blue	Drive remains still. The current speed is smaller than the value set for the ENC Stagnation Limit parameter.
3	Green	The drive has been enabled.

3.3.2.11 DRV Error Accu

ID	Index	CAN ID	CAN index	Definition
60	0-9	211B	1-10	Fault memory

Faults that cause the drive to shut off are stored here permanently. The Accu value cannot be reset. This value is stored when the drive shuts down and gets restored when the unit is powered up again. This parameter returns the fault number. The most recent fault is returned at index 0.

The manufacturer can delete the fault memory by writing a value of 0 to index 0.

Faults that require the drive to be replaced can be acknowledged by the operator by writing 0x9999 at index 9. This requires entering an operator password in the SYS Key Word parameter.

3.3.2.12 DRV Error Accu Counter

ID	Index	CAN ID	CAN index	Definition
61	0-9	211C	1-10	Fault counter

The fault counter returns the frequency of faults from the fault accumulator(Accu) entry.

Index 10 specifies how often a fault requiring replacing the drive has been acknowledged.

3.3.2.13 DRV Settings

ID	Index	CAN ID	CAN index	Definition
62	0	2120	0	Drive Settings

You can configure the general drive settings here. These settings cannot be changed during operation.

Bit	Value	Definition
0	0x0001	<p><u>0</u>: Power controlling The controller structure contains a subordinate current controller below the speed controller. The maximum currents are limited using the POW Current Max Mot/Gen parameter.</p> <p><u>1</u>: Power limiting The speed controller prescribes the value for POW Duty Cycle directly. The purpose of this is to reduce the system gain in CTL System Gain. The current controller is not activated for this purpose. Instead the current is measured and the current controller (POW Prop. Gain, POW Integ Time), is used to limit the current to the maximum values.</p>
1	0x0002	<p><u>FET control</u></p> <p><u>0</u>: Only high-side FETs are switched. Current freewheeling is realized with permanently activated low-side FETs.</p> <p><u>1</u>: Both corresponding FETs are switched. Current freewheeling over DC-link capacitor.</p>
2	0x0004	<p>POW max current</p> <p><u>0</u>: Max. current for drive and brake condition can be set separately</p> <p><u>1</u>: Max. current for drive and brake condition are set together</p>

3.4 Profile Position Mode

3.4.1 Function

Profile Position Mode is an operating mode for positioning the drive. It is based on the operating mode of the same name in the DSP402 [1].

The target position is approached using the prescribed traversing curve (accelerating ramp, speed, deceleration ramp).

To choose this operating mode, set the DRV Mode Selector parameter to 1. It is only possible to select the positioning mode when the drive is shut off.

Furthermore, you can select from 10 manufacturer-specific, storable traversing curves (each with accelerating ramp, speed and deceleration ramp).

To choose this operating mode, set the DRV Mode Selector parameter to -2 (manufacturer mode).

If a Quick Stop is initiated, the drive decelerates according to the deceleration ramp in POS Deceleration until it stops and shuts off.

3.4.1.1 Control Word Bits

The DRV Control Word parameter processes the profile-specific bits in these operating modes as follows:

Bit no.	Name	Value	Definition
4	New set-point	0	–
		1	Apply bits and start positioning
6	Abs/rel	0	Target position has been specified absolutely
		1	The target position is specified relative to the current position
8	Stop	0	–
		1	Stop the positioning process and decelerate the drive according to the deceleration ramp

3.4.1.2 Status Word Bits

The following status word bits are set in the parameter:

Bit	Name	Value	Definition
8	Out of Drive Area	0	If bit 11 has been set, the work area will be exited with a positive value
		1	If bit 11 has been set, the work area will be exited with a negative value
10	Target reached	0	–
		1	Target position has been reached or drive has stopped following "stop" signal
11	Limit active	0	–
		1	Exit work area
12	Set point ack	0	–
		1	After setting a new set point in the control word, the current values are applied
14	Drive Area	0	
		1	Exit the traversing range (D0, D1)
15	Security Area	0	
		1	Exit the security area (S0, S1)

3.4.1.3 Preset positioning procedure

As soon as the drive has been enabled, positioning can begin according to the following procedure:

- New target position is prescribed, possibly speed and acceleration as well.
- Bit 4 is set (New Set point) in the control word.
- The drive returns bit 12 (Set point Ack is set) and bit 10 (Target Reached is deleted) in the status word and starts with the new positioning task.
- It is not possible to delete bit 4 (New Set point) in the control word.
- You can, however, prescribe new set point values.
- Once the drive is completely positioned, it returns bit 10 (Target Reached is set) in the status word. The drive is ready for a new positioning task.

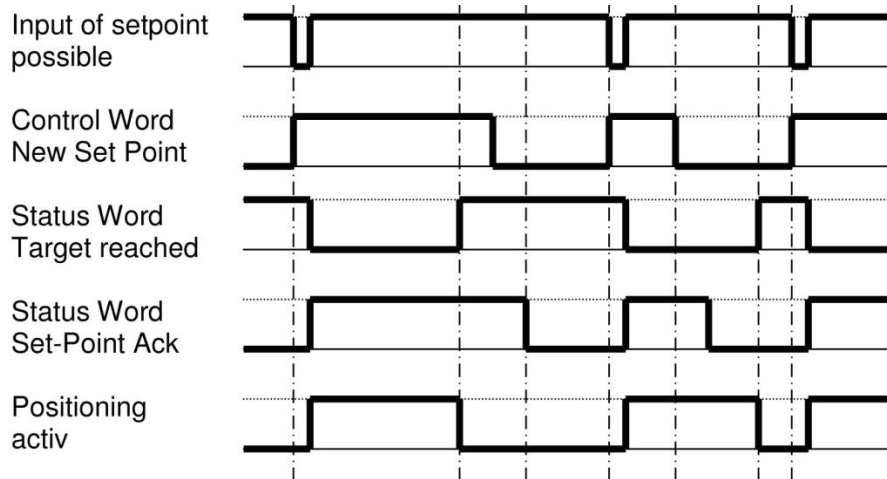

Figure 5: Positioning procedure (control and status bits)

3.4.2 Parameter List

3.4.2.1 POS UU Ratio

ID	Index	CAN ID	CAN index	Definition
70	0	2116	1	User unit (UU)
70	1	2116	2	Gearbox output revolutions

This is the relationship between the user unit (UU) and the number of gearbox output revolutions

3.4.2.2 POS Target Position

ID	Index	CAN ID	CAN index	Definition
71	0	607A	0	Target position
71	1			Second target position for test mode 1

If the SYS Key Word parameter is set to "Testmode_0", the drive begins with positioning once this value is entered and does not have to be started using the DRV Control Word parameter.

If the SYS Key Word parameter is set to "Testmode_1", once the drive is started using "New set point" in the control word, it will begin to move continuously back and forth the two positions indexed by this parameter.

3.4.2.3 POS Max. Velocity

ID	Index	CAN ID	CAN index	Definition
72		607F	0	Maximum speed

If the maximum values are changed, the corresponding current values are adapted if necessary.

3.4.2.4 POS Max. Acceleration

ID	Index	CAN ID	CAN index	Definition
73		60C5	0	Maximum acceleration

3.4.2.5 POS Max. Deceleration

ID	Index	CAN ID	CAN index	Definition
74		60C6	0	Maximum delay

3.4.2.6 POS Profile Velocity

ID	Index	CAN ID	CAN index	Definition
75	0	6081	0	Speed for operating mode 1
75	1-10	2004	1-10	Storable speeds for operating mode -2

As the positioning process starts, the value entered here is compared with the limit values in the ENC Speed Limit min/max/dif and a fault may be issued.

3.4.2.7 POS Acceleration

ID	Index	CAN ID	CAN index	Definition
76	0	6083	0	Acceleration ramp for operating mode 1
76	1-10	2005	1-10	Storable acceleration ramps for operating mode -2

3.4.2.8 POS Deceleration

ID	Index	CAN ID	CAN index	Definition
77	0	6084	0	Deceleration ramp for operating mode 1
77	1-10	2006	1-10	Storable deceleration ramp for operating mode -2

3.4.2.9 POS Current Index

ID	Index	CAN ID	CAN index	Definition
78		2007	0	Current parameter set

In operating mode -2 (Manufacturer Mode), you can select a parameter set here from any of the max. 10 traversing curves (acceleration ramp, speed, deceleration ramp) that you have stored.
In operating mode 1, the values from index 0 are used.

3.4.2.10 POS Current Position

ID	Index	CAN ID	CAN index	Definition
79				Calculated set point position

3.4.2.11 POS Wait time

ID	Index	CAN ID	CAN index	Definition
80				Waiting time

If SYS Key Word parameter is set to "Testmode_1", once the drive is started using New set point" in the control word, it will begin to move continuously back and forth between the two limit positions.
This parameter specifies the time milliseconds that the drive waits between the positions.

3.5 Profile Velocity Mode

3.5.1 Function

Profile Velocity Mode is an operating mode for controlling the speed. It is based on the operating mode of the same name in the DSP402 [1]. The speed set point is determined according to the accelerating and deceleration ramps and transferred to the controller.

To choose this operating mode, set the DRV Mode Selector parameter to 3. If a Quick Stop is initiated, the drive decelerates according to the deceleration ramp in POS Deceleration until it stops and shuts off.

Since this function is implemented as a sub function in Velocity Mode, the VEL Block Protection function is also active in Profile Velocity Mode.
The set point and actual values are calculated internally as rpm and it is not possible to calculate speeds below 1 rpm.

3.5.1.1 Control Word Bits

The DRV Control Word parameter processes the profile-specific bits in these operating modes as follows:

Bit no.	Name	Value	Definition
8	Stop	0	-
		1	Internal speed set point is set to 0.

3.5.1.2 Status Word Bits

The following status word bits are set for the parameter:

Bit no.	Name	Value	Definition
10	Target Reached	0	Set point not achieved. The bit is deleted as soon as a new speed set point is entered or the drive is stopped by the stop bit in DRV Control Word.
		1	Set point achieved. The difference between the actual speed and speed set point is smaller than the value set for the parameter VEL Window.
12	Halt	0	The speed is larger than the value in the ENC Stagnation Limit parameter.
		1	Speed = 0 (speed is lower than value of ENC Stagnation Limit parameter).
13	Max Slippage Fault	0	The slippage is 0
		1	The slippage is larger than the value of index 2 in the ENC Speed Limit min/max/dif parameter

3.5.2 Parameter List

3.5.2.1 POS Target Velocity

ID	Index	CAN ID	CAN index	Definition
81	0	60FF	0	Set point Speed for Profile Velocity Mode (3)
81	1-10	2121	1-10	Set point Speed for Profile Velocity Mode (3)

You can use the POS Current Position parameter to select the currently used value.

The set point and actual values are calculated internally as rpm and it is not possible to calculate speeds below 1 rpm.

The limit values are explained in the chapter. The acceleration values are defined in the POS Acceleration and POS Deceleration parameters.

3.5.2.2 POS Actual Velocity

ID	Index	CAN ID	CAN index	Definition
82		606C		Actual value of speed

Display of the converted actual value of speed from index 0 of ENC Speed parameter. This value is filtered.

3.6 Position Control Function

3.6.1 Function

The Position Control function monitors the current position of the drive in the positioning operating modes. It is based on the operating mode of the same name in the DSP402 [1].

The positioning module prescribes the target position and this value is compared with the current position. As soon as the current position is within a prescribed window around the target position for a prescribed time, the "Target Reached" status bit is set (see "Profile Position Mode, Function").

3.6.2 Parameter List

3.6.2.1 PCT Position Actual Value *

ID	Index	CAN ID	CAN index	Definition
90		6063	0	Position of the drive in increments

3.6.2.2 PCT Position Actual Value

ID	Index	CAN ID	CAN index	Definition
91		6064	0	Position of the drive in user units

3.6.2.3 PCT Position Window

ID	Index	CAN ID	CAN index	Definition
92		6067	0	Target window

If, following positioning, the drive is within the target window for the time given in PCT Position Window Time and the speed is lower than the stagnation limit (ENC Stagnation Limit), the positioning procedure is halted and displayed using the TARGET REACHED bit in the status word.

If the value is equivalent to the maximum value, positioning is halted without any further controlling actions after the stagnation limit time.

3.6.2.4 PCT Position Window Time

ID	Index	CAN ID	CAN index	Definition
93		6068	0	Min. positioning time within the target window

3.6.2.5 PCT Control Window

ID	Index	CAN ID	CAN index	Definition
94	0	211A	1	Active window
94	1	211A	2	Inactive window

This parameter is used to set the control window during standstills. It is possible to deactivate position controlling for the drive after it has stopped within the defined window. This prevents the drive from making noise or vibrations once it reached the target position. These functions are not activated until the positioning is completed, i.e., the drive must first return "Target Reached".

If the current position is within the active window around the position set point, position controlling is deactivated upon expiry of the time specified in PCT Position Window Time.

If, after deactivating the position controlling, the drive moves outside of the inactive window, position controlling is automatically reactivated and the drive is moved back to the active window.

This function can be shut off by defining an active window that is larger than the inactive window or by setting one of the two windows to the maximum value of 65535.

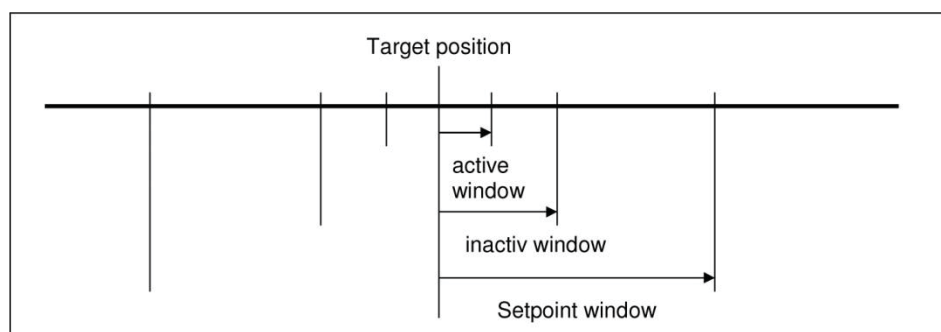

Figure 6: Partitioning of the positioning window

The positioning procedure is as follows:

- After reaching the target position, once the drive remains for longer than PCT Position Window time within the target window (PCT Position Window), the "Target Reached" bit is set in the status word.
- Once the drive has reached its target position within the active window (index 0 of PCT Control Window) for example longer than 100 ms, position controlling stops. This prevents the drive from vibrating constantly due to positioning.
- If the drive is moved outside the inactive window (index 1 of PCT Control Window) due to external influences, position controlling is activated automatically and the drive is moved back to its target position.

3.6.2.6 PCT Following Error

ID	Index	CAN ID	CAN index	Definition
95		60F4	0	Following error

3.6.2.7 PCT Following Window

ID	Index	CAN ID	CAN index	Definition
96		6065	0	Permissible following error

If the position of the drive is being controlled, you can define the size window for following errors in user units. Once the drive exits this window, a fault is issued and the drive is shut down.

This value is processed internally using the ENC Position Limit parameter and stored.

3.7 Homing Mode

3.7.1 Function

Homing Mode is an operating mode for referencing the drive. It is based on the operating mode of the same name in the DSP402 [1].

To choose this operating mode, set the DRV Mode Selector parameter to 6. It is only possible to select the homing mode when the drive is shut off.

There are three areas that can be referenced in addition to the current position:

- Working area; area within which the drive can be positioned
- Traversing range; area within which the drive can move on the way towards the working area
- Safety area; area to which the drive can be moved back manually

The limit values cannot be changed while the drive is switched on. If the limit values are changed, the drive loses its reference and must be re-referenced.

3.7.1.1 Control Word Bits

The DRV Control Word parameter processes the profile-specific bits in these operating modes as follows:

Bit no.	Name	Value	Definition
4	Homing operation start	0	–
		1	Apply current values

Since the control word is only applied when it differs from the current value, it is not possible to reference the drive twice successively. Referencing requires a rising edge signal in the "Homing operation start" bit.

3.7.1.2 Status Word Bits

The following status word bits are set in the parameter:

Bit no.	Name	Value	Definition
12	Homing attained	0	–
		1	Referencing executed
13	Homing Error	0	–
		1	Error during referencing

Once referencing is complete, "Drive Referenced" (bit 24) is set in the "SYS Manu. Bit 24 ("Drive Referenced") has been set in status register parameter.

3.7.2 Parameter List

3.7.2.1 HOM Homing Method

ID	Index	CAN ID	CAN index	Definition
110		6098	0	Referencing method (fixed -1 → specific to manufacturer)

3.7.2.2 HOM Homing Speed

ID	Index	CAN ID	CAN index	Definition
111		6099	1/2	Homing speed

You can enter the value for the traversing speed during referencing here (as prescribed by CANopen). Since the drive does not move during referencing, this parameter is meaningless.

3.7.2.3 HOM SW Pos. Safety Limit

ID	Index	CAN ID	CAN index	Definition
112	0	2008	1	Minimum limit for safety area
112	1	2008	2	Maximum limit for safety area

3.7.2.4 HOM SW Position Drive Limit

ID	Index	CAN ID	CAN index	Definition
113	0	2009	1	Minimum limit for traversing range
113	1	2009	2	Maximum limit for traversing range

3.7.2.5 HOM SW Position Limit

ID	Index	CAN ID	CAN index	Definition
114	0	607D	1	Minimum limit for working area
114	1	607D	2	Maximum limit for working area

3.7.2.6 HOM Pos. Assignment Value

ID	Index	CAN ID	CAN index	Definition
115		200B	0	Set point for reference position

This value is applied as the current position after setting bit 4 (Homing Operation Start) in the DRV Control Word parameter.

3.8 Velocity Mode

3.8.1 Function

Velocity Mode is an operating mode for prescribing the speed. It is based on the operating mode of the same name in the DSP402 [1].

The speed set point is determined according to the accelerating and deceleration ramps and transferred to the controller.

To choose this operating mode, set the DRV Mode Selector parameter to 2.

If a Quick Stop is initiated, the drive decelerates according to the deceleration ramp in VEL Deceleration until it stops and shuts off.

3.8.1.1 Control Word Bits

The DRV Control Word parameter processes the profile-specific bits in these operating modes as follows:

Bit no.	Name	Value	Definition
4	Enable	0	The speed is set by a function generator that prescribes the set point for 5 seconds and then pauses the drive for 5 seconds. This bit has higher priority than all other bits!
		1	The standard speed set point is reached by accelerating towards the speed according to the defined ramps.
5	Unlock	0	–
		1	–
6	Use ref	0	Internal speed set point is set to 0.
		1	The standard speed set point is reached by accelerating towards the speed according to the defined ramps.
8	Stop	0	–
		1	Internal speed set point is set to 0.

3.8.1.2 Status Word Bits

The following status word bits are set in the parameter:

Bit no.	Name	Value	Definition
10	Target reached	0	Set point not achieved. Bit is deleted as soon as a new speed set point is entered or drive stopped by a bit in DRV Control Word.
		1	Set point achieved. The difference between the actual speed and speed set point is smaller than the value set for the parameter VEL Window.

3.8.2 Parameter List

3.8.2.1 VEL Target

ID	Index	CAN ID	CAN index	Definition
130		2011 6042	2 0	Set point speed

In "Manual Mode", this parameter is written internally and therefore cannot be changed.

3.8.2.2 VEL Acceleration

ID	Index	CAN ID	CAN index	Definition
131		2011 6048	3 1	Acceleration ramp

3.8.2.3 VEL Deceleration

ID	Index	CAN ID	CAN index	Definition
132		2011 6049	4 1	deceleration ramp

3.8.2.4 VEL Polarity

ID	Index	CAN ID	CAN index	Definition
133		607E	0	Direction of rotation

Value	Definition
0	Clockwise
1	Counter clockwise

The speed can be changed during operation; the drive changes direction according to the ramp that has been defined.

In "Manual Mode", this parameter is written internally and therefore cannot be changed.

3.8.2.5 VEL Window

ID	Index	CAN ID	CAN index	Definition
134		606D	0	"Target Reached" window

To set bit 10 ("Target Reached") in Velocity operating mode, the difference between the current speed and speed set point must be less than the value specified here. The status bit is deleted as soon as the value is outside of this window.

Changes to the status bit are not made until the speed remains stable for the duration specified by the VEL Window Time parameter.

3.8.2.6 VEL Window Time

ID	Index	CAN ID	CAN index	Definition
135		606E	0	Time for "Target Reached" window

VEL Window Time is the duration required at a stable speed before the "Target Reached" status bit is set in parameter DRV Status Word. See VEL Window.

3.8.2.7 VEL Block Protection

ID	Index	CAN ID	CAN index	Definition
136		201F	0	Maximum blocking time

If, while remaining still, the drive current or voltage limits are exceeded for a period of time longer than the stagnation limit specified here (see ENC Stagnation Limit parameter), error 7120 is issued and the motor is shut down. A value of 0 deactivates blocking monitoring.

This value is monitored using a counter that increments if the motor is blocked and decrements as soon as the blockage has been eliminated.

3.9 Manual mode

3.9.1 Function

"Manual" operating mode is the predefined operating mode. The drive can only be controlled using the digital and analogue inputs.

To choose this operating mode, set the DRV Mode Selector parameter to a value of -1.

The "Start" input switches the drive on. A rising edge signal (0 to 1) must be achieved at this input in order to start the drive. Switching the drive on in this mode always deletes any existing warnings. If the drive is in a fault status, the fault status is cleared if possible.

If a HIGH signal is set at the "Brake" input, the drive is decelerated to a speed of 0.

The "Direction of Rotation" input is used to reverse the direction of rotation. "High" is equivalent to counter clockwise.

Analogue input 1 is used to prescribe the speed. This is configured using the IO Analogue Input 1. In this operating mode, the parameter IO Analogue Input 1 is automatically set to mode "1" (speed set point). The speed set point range can be prescribed using the IO Analogue Input 1 parameter.

3.10 Torque profile

This module defines the torque control parameters.

To select this operating mode, set the DRV Mode Selector to 4.

3.10.1 Function

The drive is controlled to the set torque.

The set point is approached using the defined ramp function.

Using the set point, the module calculates the ramp function and the current speed for a current set point.

The DDA Torque Constant parameter is used to convert the torque to the current set point. To compensate the motor losses, the characteristic given by DDA Loss Speed and DDA Loss Current is used.

If the torque set point is 0 Ncm, the current is set to a fixed value of 0, regardless of the speed and any motor losses.

3.10.1.1 Control Word Bits

The DRV Control Word parameter processes the profile-specific bits in these operating modes as follows:

Bit no.	Name	Value	Definition
4	–	0	–
		1	–
5	–	0	–
		1	–
6	–	0	–
		1	–
8	Stop	0	Executes torque controlling.
		1	Sets internal torque set point to 0.

3.10.1.2 Status Word Bits

The following status word bits are set in the parameter:

Bit no.	Name	Value	Definition
10	Target reached	0	Set point not achieved. The bit is deleted as soon as a new torque set point is entered or the drive is stopped by the stop bit in DRV Control Word.
		1	Set point achieved. The ramp function of the torque set point has reached the value for TOR Target Torque.

If a Quick Stop is initiated, the torque set point is reduced to 0 and the drive shuts down.

3.10.2 Parameter List

3.10.2.1 TOR Target Torque

ID	Index	CAN ID	CAN index	Definition
140		6071	0	Set point

3.10.2.2 TOR Torque Slope

ID	Index	CAN ID	CAN index	Definition
141		6087	0	Ramp

3.10.2.3 TOR Torque Current

ID	Index	CAN ID	CAN index	Definition
142				Current motor current

The configured torque can be converted to current using the DDA Torque Const und DDA Los Current parameter (motor loss compensation). This value is displayed here.

3.11 Encoder

3.11.1 Function

This module evaluates the position encoder of the drive and uses this to calculate the current speed and position.

3.11.2 Parameter List

3.11.2.1 ENC Lines

ID	Index	CAN ID	CAN index	Definition
180				Resolution

This parameter returns the encoder resolution in increments/revolution. This is a factory setting and can only be changed by the manufacturer.

If a value of 3 is entered, the module will use the three commutating sensors to calculate the speed and position instead of the optical encoder.

If the parameter is changed, the drive loses its reference position and must be referenced.

3.11.2.2 ENC Resolution

ID	Index	CAN ID	CAN index	Definition
181		608F	1	Internal resolution

The internal resolution is four times the value of the incremental number.

3.11.2.3 ENC Position

ID	Index	CAN ID	CAN index	Definition
182				Current position

If the drive is referenced, this parameter returns the current position.

3.11.2.4 ENC Motor Position

ID	Index	CAN ID	CAN index	Definition
183				Current motor position during motor rotation

3.11.2.5 ENC Speed

ID	Index	CAN ID	CAN index	Definition
184	0	6044 6069	0 0	Speed (filtered)
184	1			Speed (unfiltered)

3.11.2.6 ENC Speed Limit min/max/dif

ID	Index	CAN ID	CAN index	Definition
185	0	6046	1	Minimum permissible speed
185	1	6046	2	Maximum permissible speed
185	2	211E	0	Permissible speed difference

The minimum speed is entered into index 0. Set points lower than this value are not accepted.

If an optical encoder (490 increments) is used, this speed should not be below 15 rpm. If the drive is operated using a commutating sensor, speeds below 75 rpm are not allowed.

Index 1 specifies the maximum permissible speed. If this value is exceeded, an error is issued.

A value of 0 switches off the monitoring function.

Index 2 specifies the maximum permissible speed difference. If the drive goes beyond this value, a fault is issued. A value of 0 deactivates this monitoring.

3.11.2.7 ENC Position Limit

ID	Index	CAN ID	CAN index	Definition
186		2117	0	Following error limit

If the position controlling is currently enabled, this parameter is used to monitor following errors. Once the following error goes beyond the permissible value, a fault is issued.

See also PCT Following Window parameter.

3.11.2.8 ENC Gear Ratio

ID	Index	CAN ID	CAN index	Definition
187	0	6091	1	Revolutions of motor shaft
		6510	5	
187	1	6091	2	Revolutions of gearbox output shaft
		6510	4	

If this value is changed, the drive loses its reference and must be referenced.

3.11.2.9 ENC Stagnation Limit

ID	Index	CAN ID	CAN index	Definition
188		2114	0	Stagnation speed

If the speed goes below this value, the drive issues a standstill message. This value is used for DRV Status LEDs.

The positioning is not signaled as complete until the drive speed is smaller than the value specified by ENC Stagnation Limit.

3.11.2.10 ENC Ref. Motor Position

ID	Index	CAN ID	CAN index	Definition
189				Stored motor position

This value is set to zero during referencing. Otherwise, the most recently stored motor position is used (see ENC Motor Position Error).

3.11.2.11 ENC Motor Position Error

ID	Index	CAN ID	CAN index	Definition
190		2115	0	Deviation between motor position and stored reference value

Deviation in increments between motor axle and most recently stored reference value.

If the motor is referenced in homing mode, a reference position is also stored for the motor at a definite Hall sensor transition point where the motor position is set to zero. If the voltage is interrupted, the difference between the motor's current position and the reference position is evaluated.

Note: There are 6 different Hall sensor patterns, each of which occurs twice per motor revolution. If the voltage is interrupted, the current Hall sensor pattern of the motor is stored. After the drive is switched on again, a check is performed whether the motor is +/- 1 relative to this Hall sensor pattern. If not, the reference position is deleted and the drive is set as "unreferenced". Otherwise, the stored positions are used and the fault is determined when the drive starts up again.

3.11.2.12 ENC Filter

ID	Index	CAN ID	CAN index	Definition
191		2010	9	Filter time constant

The current speed measured in increments per sampling time is converted and filtered. The filter constant can be entered here.

If the drive is only operated with Hall sensors, i.e., without optical encoders, the speed signal is filtered in advance from the Hall sensors. It is not necessary the filter the signal again. The ENC Filter can be turned off by setting the filter constant to 1.

3.12 Control

3.12.1 Function

This module contains a combined speed-position controller for the drive. Depending on the operating mode, the set points can be generated using the corresponding module.

3.12.2 Parameter List

3.12.2.1 CTL Reference

ID	Index	CAN ID	CAN index	Definition
200	0			Position set point
200	1			Speed set point
200	2			Position deviation
200	3			Speed deviation
200	4			Current integral value
200	5			Maximum integral value
200	6			Maximum negative position deviation
200	7			Maximum positive position deviation
200	8			Factor of I-controller
200	9			Current speed value in increments per sampling interval of speed/position controller

This parameter returns a few controller-specific quantities and all values are given in increments.

3.12.2.2 CTL Prop. Gain

ID	Index	CAN ID	CAN index	Definition
201		2010	2	Gain of speed controller

3.12.2.3 CTL Integ. Time

ID	Index	CAN ID	CAN index	Definition
202		2010	4	Adjustment time for speed controller

3.12.2.4 CTL System Gain

ID	Index	CAN ID	CAN index	Definition
203		2010	5	System gain

The system gain depends on the load.

If the controller structure is configured as a subordinated current controller using the DRV Settings parameter, the system gain can be set as follows:

1. Drive operating in torque/current controller mode.
2. Capture speed.
3. Switch on drive
4. Set the current set point to a value that is not too small, e.g., 5A.
5. The drive runs until it reaches the over speed limit and then shuts down automatically.
6. The slope at the zero point of the speed is equivalent to the drive acceleration.
7. The system gain can be calculated as follows:

Δ speed [rpm]

Δ acceleration time [s] * current [A]

Example:

1800 rpm
----- = 600 rpm/sA
0.6 s * 5 A

Instead of 600 rpm/sA, we use a system gain of 1000 rpm/sA to prevent the resulting gain from becoming too large as well as to provide a representation of the braking behavior.

3.12.2.5 CTL Position Gain

ID	Index	CAN ID	CAN index	Definition
204		2010	1	Gain of position controller

If a value >0 is entered here, the position controller is enabled in the positioning and speed operating modes. It is not possible to do positioning without the position controller.

3.12.2.6 CTL Position Pre Factor

ID	Index	CAN ID	CAN index	Definition
205	0	2010	3	Pilot value for speed controller. This is value is only relevant for position controlling. Recommended value: 1.00
205	1	2010	6	Acceleration pilot value. Acceleration pilot value for speed controller. Recommended value: 0.00

Currently, both pilot value modes are not enabled!

3.12.2.7 CTL Set Value

ID	Index	CAN ID	CAN index	Definition
206		606B		Current speed set point after generating ramp function

3.13 Power

3.13.1 Function

The module processes the current set points and generates the signals required for PWM.

This module can operate as a current controller or current limiting controller (see DRV Settings).

Current controller: The module receives a current set point from the speed controller. The actual value is corrected by the current controller with its own frequency.

Current limiting controller: The speed controller prescribes the duty cycle directly. Only the current is measured. If the actual current value exceeds the maximum permissible value, the duty cycle is reduced.

The actual current is measured in cycles. If this value exceeds 35 A, the drive is shut down immediately and fault 0x2221 is issued.

If operating mode -3 is selected, the POW Duty Cycle parameter can be used to adjust the amount of transistor drive. This operating mode is protected by the Heidrive password in the SYS Key Word parameter.

3.13.2 Parameter List

3.13.2.1 POW Duty Cycle

ID	Index	CAN ID	CAN index	Definition
220		2118	0	PWM duty cycle

This value returns the actual duty cycle of the powerstage.

3.13.2.2 POW Prop. Gain

ID	Index	CAN ID	CAN index	Definition
221		2010	7	Gain of current controller

3.13.2.3 POW Integ. Time

ID	Index	CAN ID	CAN index	Definition
222		2010	8	Adjustment time for current controller

3.13.2.4 POW Current Set Value

ID	Index	CAN ID	CAN index	Definition
223				Current set point

This value is set by the controller.

If the controller is operated in current limiting mode (see DRV Settings), the duty cycle set point relative to the nominal current is displayed here.

3.13.2.5 POW Current Act Value

ID	Index	CAN ID	CAN index	Definition
224		6078	0	Actual current

3.13.2.6 POW Current Max Mot/Gen

ID	Index	CAN ID	CAN index	Definition
225	0	2011 6073	5 0	Maximum current in motor operating mode
225	1	2011	6	Maximum current in generator operating mode This value is limited by the POS Current Offset parameter, (including measurement reserve)

Using this parameter, you can set the maximum permissible current. We differentiate between motor-based and generator-based operation. This value limits the current set point.

If limitation is active, this is indicated by the red LED in HAT.

To allow the drive to recover energy during braking, the limit value for generator mode must be higher than 0 and a speed must be prescribed in the POW Break Speed parameter.

Even when energy is not to be fed back, the generator limit value should be set to value larger than 0 so that the drive can accelerate smoothly from standstill. This is also equivalent to the holding torque until the standstill speed is reached. Based on the stall speed, the torque is always 0.

3.13.2.7 POW Hall Pattern

ID	Index	CAN ID	CAN index	Definition
226	0			Current Hall sensor pattern
226	1			State of Hall sensor pattern (0 – 5), depends on Hall sensor pattern
226	2			Hall sensor mode: 0xfffd Counter clockwise counter field braking 0xfffe Counter clockwise braking 0xffff Counter clockwise driving 0x01 Clockwise driving 0x02 Clockwise braking 0x03 Clockwise counter field braking
226	3			PWM fault

Returns the actual data from the Hall sensors and PWM generation.

3.13.2.8 POW Max Duty Cycle Mot/Gen

ID	Index	CAN ID	CAN index	Definition
227	0	2119	1	Maximum duty cycle in motor mode
227	1	2119	2	Maximum duty cycle in generator mode
227	2			Active maximum duty cycle in generator mode

Maximum value used for limiting duty cycle of power component.

We differentiate between motor-based and generator-based operation. If limiting is active, this is indicated by the red LED in HAT.

To allow the drive to recover energy during braking, the limit value for generator mode must not be larger than 90%, since otherwise the current cannot be measured in this mode.

The momentary active value for generator mode can be read from index 2. This value may be lower than the value stored in index 1, if the DC link voltage increases by the value in the parameter due to the energy recovery (see below).

3.13.2.9 POW I²t Value

ID	Index	CAN ID	CAN index	Definition
228		2111	0	I ² t value

The driver heating is controlled by I²t monitoring.

The drive has been modeled for this purpose. The model is a PT1 element with a time constant specified by the POW I²t Delay Time parameter. The model should have a value of 100% if the drive is permanently operated with its nominal current (DDA Nom Motor Current parameter).

Since this is only a model, this value may deviate from the theoretical value of 100%.

3.13.2.10 POW I²t Limit

ID	Index	CAN ID	CAN index	Definition
229	0	2112	1	Warning limit of I ² t monitoring
229	1	2112	2	Fault limit of I ² t monitoring

If the actual I²t value in the POW I²t Value parameter exceeds the limits specified here, a warning or fault message is issued.

A value of 0 switches off the monitoring function.

3.13.2.11 POW I²t Delay Time

ID	Index	CAN ID	CAN index	Definition
230		2113	0	Time constant of drive module for I ² t monitoring.

Note on setting:

If the drive is operated at nominal current (indicated by POW Current Act Value parameter in HAT graphs), the time constant is the time required by the drive to warm up to 63% of the nominal temperature.

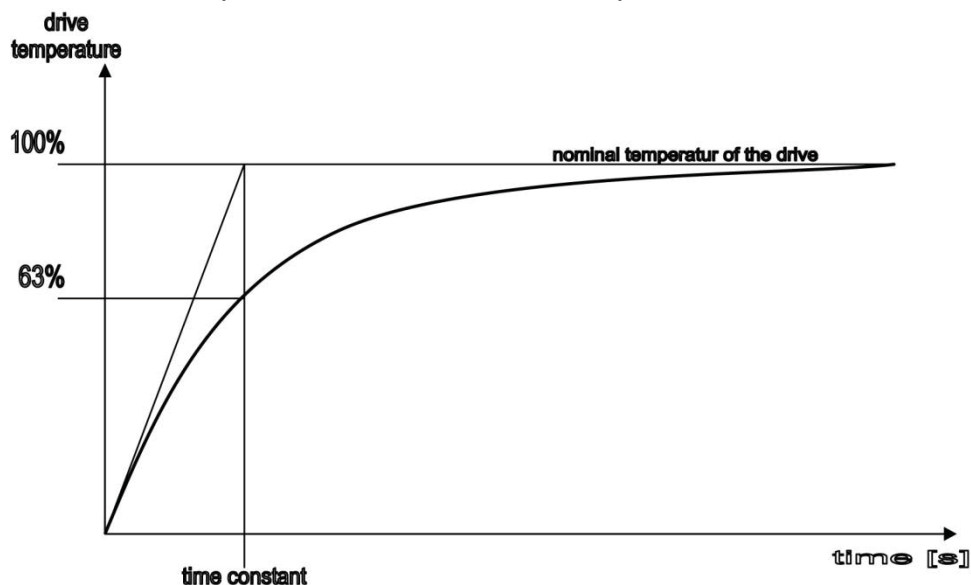

Figure 7: Drive temperature curve as a function of time

3.13.2.12 POW Brake Speed

ID	Index	CAN ID	CAN index	Definition
231		211D	0	Speed above which braking energy is recovered by system

Below this brake speed, the motor EMF is too small to generate sufficient energy for braking and the drive is braked using a magnetic counter field. If this value is set -1, energy will never be recovered and a magnetic counter field will also not be used for braking. The drive runs down without power until active braking is required. Values above 1000 U/min generate large commutating currents and should therefore only be used with caution.

Note:

The maximum generator current must be entered in the POW Current Max Mot/Gen parameter so that energy can be recovered. For more information, see chapter 4.3 "Active Braking".

3.13.2.13 POW Brake Voltage

ID	Index	CAN ID	CAN index	Definition
232	0			Lower limit value of DC link voltage
232	1			Upper limit value of DC link voltage

If the drive is in braking mode and energy is being recovered by the DC link, the DC link voltage is monitored. Once it goes below the lower limit value (index 0), the maximum generator PWM duty cycle (POW MAX Duty Cycle Mot/Gen) is limited. If the voltage continues to increase to the upper limit, the maximum duty cycle is reduced proportionally to 0%. This algorithm ensures that the DC link voltage fluctuates between the upper and lower limit values.

Higher voltage voltages may occur before the controller takes effect. Therefore, the limit value must be significantly lower than the maximum value in the DDA Min/Max Voltage parameter.

It is only practical to use duty cycle limiting in speed mode. If the position controller is active, a following error may occur during limiting and this can cause the motor to shut down.

If the motor is being limited, this is indicated by the red LED in the PC interface.

3.13.2.14 POW Current Offset

ID	Index	CAN ID	CAN index	Definition
233				Current measurement offset

At the same time, this is also the maximum possible negative current, i.e., the current that can be used for braking.

3.13.2.15 POW Max Over Current

ID	Index	CAN ID	CAN index	Definition
234				Maximum permissible over current for fault counter

An internal counter will allow the number of over current events specified here to occur before issuing fault 0x2221 (positive over current) or 0x2222 (negative over current).

3.13.2.16 POW Limit Reason

ID	Index	CAN ID	CAN index	Definition
235				Cause of current limiting

There are several reasons why the drive can enter current limiting. This is indicated in parameters and by a red LED in PC interface. The precise cause of the limiting can be read from the bit mask of the POW Limit Reason parameter.

When enabling and writing to the parameter, the value is deleted. Otherwise the bits are kept and multiple causes can occur at once.

Bit	Value	Limiting due to:
0	0x0001	Voltage limit, motor-based Maximum motor-based duty cycle using POW Max Duty Cycle Mot/Gen index 0
1	0x0002	Voltage limit, generator-based Maximum generator-based duty cycle using POW Max Duty Cycle Mot/Gen index 1/2
2	0x0004	Brake delay due to over voltage See POW Brake Voltage
3	0x0008	Current limiting controller, see DRV Settings
4	0x0010	Positive motor-based current limiting See POW Current Max Mot/Gen
5	0x0020	Negative motor-based current limiting See POW Current Max Mot/Gen
6	0x0040	Positive generator-based current limiting See POW Current Max Mot/Gen
7	0x0080	Negative generator-based current limiting See POW Current Max Mot/Gen

If there are multiple causes present, the values are added together. Thus, a value of 0x0091 indicates that motor-based voltage limit, positive motor-based current limiting and negative generator-based current limiting were all active.

3.14 Input Output

3.14.1 Function

This module processes the digital and analogue inputs/outputs. The analogue inputs have a resolution of 10 bits.

Analogue input 1 can be optionally equipped with a 12-bit AD converter.

3.14.2 Parameter List

3.14.2.1 IO Analogue Register

ID	Index	CAN ID	CAN index	Definition
240	0			NTC temperature measurement power board
240	1			Analogue input 1
240	2			Analogue input 2
240	3			Voltage of DC link
240	4			NTC temperature measurement controller board
240	5			Analogue input 1 is measured using an external 12-bit AD-converter. A value will only be displayed when the input is equipped with the optional AD converter.

The parameter returns the values from the analogue inputs at a resolution of 12 bits.

These values are only used internally and the values are displayed using their own parameters.

3.14.2.2 IO Digital Inputs

ID	Index	CAN ID	CAN index	Definition
241		60FD	0	Digital inputs

Bit	Definition
0	Controller enable L: Controller disabled, drive cannot be switched on or switches off H: Controller has been activated, drive is ready to be switched on
1	Start L: Drive is switched off H: Drive is switched on
2	Brake L: Brake is switched off H: Drive brakes according to the deceleration ramp function that has been set
3	Direction of rotation Parameter 57, DRV Polarity = 0: L: Clockwise H: Counter clockwise Parameter 57, DRV Polarity = 1 L: Counter clockwise H: Clockwise
4	Reserve
5	
6	
7	
8	Motor over temperature
9	Fault from bridge driver
10	
11	
12	
13	
14	
15	

3.14.2.3 IO Analogue Input 1

ID	Index	CAN ID	CAN index	Definition
242	0			Mode: 0 Switched off 1 Speed set point (target value) for velocity mode is generated cyclically
242	1			Minimum voltage value in mV
242	2			Maximum permissible voltage value in mV
242	3			Output value for minimum voltage value
242	4			Output value for maximum voltage value
242	5			Filter constant, 0 disables filtering
242	6			Filter, analogue values in digits

Using this parameter, you can configure analogue input 1.

If it is equipped with an external AD converter (12 bits), this value is used. If not, the value from the internal AD converter is used instead.

3.14.2.4 IO Temperature

ID	Index	CAN ID	CAN index	Definition
244	0	200D	1	Temperature power component
244	1	200D	2	Temperature controller component

Display of current temperature in drive electronics

3.14.2.5 IO Temp. Limit

ID	Index	CAN ID	CAN index	Definition
245	0	2110 6510	1 3	Warning limit for temperature power component
245	1	2110 6510	2 2	Fault limit for temperature power component
245	2	2110	3	Warning limit for temperature controller component
245	3	2110	4	Fault limit for temperature controller component

Specifies the temperature limits.

If the warning limit is exceeded, an entry is only made in the DRV Error Stack parameter but the drive is not shut down. If the fault limit is

exceeded, the drive is shut down immediately and a fault is set in the DRV Error Stack parameter.

3.14.2.6 IO Frequency Output

ID	Index	CAN ID	CAN index	Definition
246	0			Mode: 0 Switched off 1 Actual speed filtered 2 Actual speed unfiltered 3 Speed set point
246	1			Minimum speed value
246	2			Maximum speed value
246	3			Output frequency for minimum speed value
246	4			Output frequency for maximum speed value

Using this parameter, you can configure the speed output. You can set frequencies ranging from 0 to 3 kHz. The resolution is 1 Hz. If the minimum speed is set to 0 or a positive value, the absolute values are used and pulses are generated for negative speeds, too.

3.14.2.7 IO DC Voltage

ID	Index	CAN ID	CAN index	Definition
247		6079	0	DC link voltage
247		2122	0	Logic-supply (Pin 10)

If the actual voltage is too low or too high, a fault is issued and the drive is shut down. The valid range is given in the DDA Min/Max Voltage parameter.

3.15 CAN Open

The drive uses a device profile as specified in DSP402 CAN Open for drives and motors. The communications profile DS-301 is supported.

Most CAN objects are displayed using parameters. Their function is thus equivalent to the corresponding parameter.

A listing of all available objects can be found in the electronic specifications and in the "Eds_ek.htm" file. The appendix contains a list of the relationship between objects and parameters.

3.15.1 Function

The CAN open stack of the drive supports the following mechanisms:

- SDO Transfer
- PDO transfer event and sync-controlled
- Fault messages with emergency messages
- NMT Slave
- LSS

3.15.2 Parameter List

The following parameters are available for displaying states and setting values.

3.15.2.1 CAN State

ID	Index	CAN ID	CAN index	Definition
260				State of CAN stack

Bit	Definition
0	LSS running
1	Stack in "Stopped" state
2	Stack in "Preoperational" state
3	Stack in "Operational" state
4	CAN warning, CAN passive fault, no remote station
5	CAN fault, bus switched off
6	LSS fault
7	NMT fault

Bits 4 or 5 indicate that the CAN bus is not active. If these bits have been set, no messages (TPDOs and Emergency) will be sent; the CAN application is in a fault state. This state is exited once the drive receives an NMT message or SDO access is initiated.

3.15.2.2 CAN Node ID

ID	Index	CAN ID	CAN index	Definition
261				Node ID

If the node ID is set using the LSS protocol, this is displayed here.

3.15.2.3 CAN Baudrate

ID	Index	CAN ID	CAN index	Definition
262				CAN baudrate

If the bit rate is sent using the LSS protocol, this is displayed here.

3.15.2.4 CAN Guardtime

ID	Index	CAN ID	CAN index	Definition
263		100C	0	Guardtime

The node monitoring time is the time during which the device is queried by the master. Together with the lifetime factor, this object defines the lifetime of the device. Once the product of the lifetime factor and the monitoring time elapses, communication with the device is considered to be interrupted (see also object 100D).

Since this value can be stored, it has to be represented by a parameter.

3.15.2.5 CAN Lifetime factor

ID	Index	CAN ID	CAN index	Definition
264		100D	0	Lifetime factor

Together with the monitoring time, the lifetime factor defines the lifetime of the device (see also object 100C).

Once the product of the lifetime factor and the monitoring time elapses, communication with the device is considered to be interrupted.

Since this value can be stored, it has to be represented by a parameter.

3.15.2.6 CAN Load

ID	Index	CAN ID	CAN index	Definition
265				CAN bus load

This parameter indicates how many messages have been processed within the last second. This includes all messages on the bus, not just the messages at this node.

3.16 Memory

3.16.1 Function

The module stores the actual parameters in EEPROM. There are two areas there, one for factory settings and one for application settings.

The parameters in the factory area can only be modified and stored by the manufacturer.

3.16.2 Parameter List

3.16.2.1 MEM Command

ID	Index	CAN ID	CAN index	Definition
280		1010 1011	0-3 0-3	Memory command

Value	Definition
1	Read single parameter from the application area
2	Read all parameters from the application area
3	Write single parameter to the application area
4	Write all storable parameters to the application area
5	Clear all stored parameters from the application area
6	Read single parameter from the factory area
7	Read all parameters from the factory area
8	Write single parameter to the factory area
9	Write all storable parameters to the factory area
10	Clear all stored parameters from the factory area
11	Read from the user data area
13	Store the user data area
15	Clear the user data area
34	Reset the log book (manufacturer's password required)
35	Initialize the memory (manufacturer's password required); MEM ID also has to be set.

3.16.2.2 MEM ID

ID	Index	CAN ID	CAN index	Definition
281				Parameter ID

MEM Error in order to read or write a single parameter, the ID has to be entered for the parameter.

3.16.2.3 MEM Error

ID	Index	CAN ID	CAN index	Definition
282	0			Display of fault number, see fault list.
282	1			Display of parameter ID where fault has occurred.
282	2			Display of commands where faults have occurred.
282	3			Internal state at time of fault occurrence.

Display of most recent fault after writing of MEM Command.

A fault memory has also been implemented.

To view the memory contents, specify the memory address in index 0. Memory address 0 always contains the current fault, and it is cleared automatically after sending a new command.

The previous faults are stored at the next memory addresses. These are not deleted.

3.16.2.4 MEM Drive Logbook

ID	Index	CAN ID	CAN index	Definition
283	0	200E	1	Switch-on time in seconds (drive is powered)
283	1	200E	2	Enable time in seconds (drive in controller mode)
283	2	200E	3	Number of positionings
283	3	200E	4	Number of reference losses
283	4	200E	5	Number of log book losses
283	5			Stored position in increments
283	6			Stored position of Hall sensors
283	7			Stored motor position

Display of actual log book content. The log book is stored automatically at shutdown and backups are created every 12 hours.

3.16.2.5 MEM Drive Logbook Backup

ID	Index	CAN ID	CAN index	Definition
284	0			Switch-on time in seconds (drive is powered)
284	1			Enable time in seconds (drive in controller mode)
284	2			Number of positionings
284	3			Number of reference losses
284	4			Number of log book losses
284	5			Seconds counter since last storage

Safety copy of actual log book. The log book is stored automatically at shutdown and backups are created every 12 hours.

3.16.2.6 MEM Par.Set Number

ID	Index	CAN ID	CAN index	Definition
285				Parameter set number

The parameter set number is specified by the manufacturer and can be changed once the manufacturer enters his password in the SYS Key Word parameter. The application data is also backed up while storing this data.

If the user backs up the application data, this is specified by a negative parameter number. In other words, a negative parameter set number indicates that the user may have changed the original parameter set and saved it new.

4 Special Functions, Setting Hints

4.1 Use of Hall Sensors

For simple tasks, the drive can be operated solely with Hall sensors and without the optical encoders.

The following settings are required for this:

Parameter	Value	Explanation
ENC Lines	3	The three Hall sensors are used to capture the current speed and position.
ENC Filter	1	The speed detected by the Hall sensors is evaluated automatically and no further filtering is required.
ENC Speed Limit min/max Index 0	75	Minimum speed in rpm When using Hall sensors, the speed cannot be set below this value. Otherwise, true running can no longer be guaranteed.
CTL Prop. Gain CTL Position Gain	Reduce	The lower resolution means that the controller gain has to be reduced.
POS UU Ratio		Adapt this to the new resolution
ENC Position Limit PCT Following Window		Adapt this to the new resolution

4.2 Adaptive Controller Tuning

For a detailed description of this function, refer to the corresponding documentation.

4.3 Active Braking

In 4Q mode, the drive uses active braking, i.e., energy is returned to the power supply. The recovered energy must be utilized or expended by an external circuit because the drive cannot consume it. The maximum permissible voltage must not be exceeded.

Active braking can be enabled using the following parameters:

Parameter	Value	Explanation
POW Brake Speed	≥0 rpm	If the speed is larger than the set value, energy can be recovered. Otherwise a magnetic counter field is applied. A typical value is 600 rpm
POW Current Max Mot/Gen Index 1: generator-based	>0A	The maximum generator-based current must be set at index 1. If this value is zero, no energy will be recovered.
POW Max Duty Cycle Mot/Gen Index 1: generator-based	90%	To measure the recovered current, the duty cycle must be limited in generator-based mode.
VEL Deceleration Pos Deceleration		Depending on the operating mode, the delay time must be set so that the motor does not operate at the current limit.

Example:

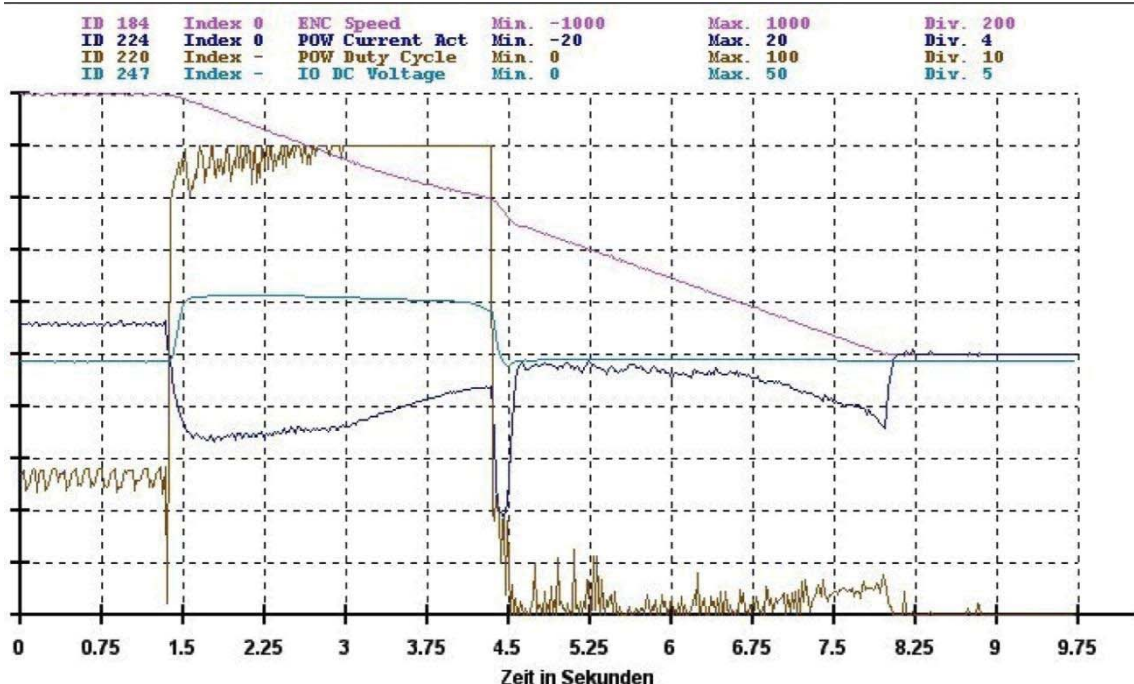

Figure 8: Braking example

The figure shows braking from 1000 rpm to 0 rpm in Velocity mode. Figure 8: Braking example displays the speed, current, duty cycle and DC link voltage. The POW Brake Speed parameter is set to 600 rpm, the currents are limited to 14A (motor-based) and 8A (generator-based). The duty cycle is limited to 90%.

Braking begins after 1.4 seconds, current becomes negative and the voltage increases. At 3 seconds, the duty cycle is limited and the current decreases again. After this, braking is reduced and the delay time decreases. At 4.4 seconds, the braking speed reaches 600 rpm and the magnetic counter field is switched on. As a result of the existing controller error, the current strongly increases at first. At 8 seconds, the braking procedure is complete.

To prevent controller offsets from occurring during braking, the braking speed should be increased to 800 rpm (duty cycle of 800 rpm is still below limit) or the delay ramp should be reduced.

The current motor state is displayed in index 2 of the POW Hall Pattern parameter. This differentiates between drive mode, braking with energy recovery (above POW Brake Speed) and braking with a magnetic counter field (below POW Brake Speed).

5 Parameter Table

Parameter	CAN ID/index	Parameter Name
1	0x100A.0 0x2002.0 0x2003.0	SYS Version
2		SYS Build Date
3		SYS Cycle Times
4		SYS Storage
5		SYS Key Word
6		SYS Load
7		SYS Last Reset
8		SYS Ser. Baudrate
9		SYS Name
20	0x1008.0	DDA Device Name
21	0x2100.0	DDA Serial No. Electronic
22	0x1018.4	DDA Serial No. Drive
23	0x1018.2	DDA Product Code
24	0x1009.0	DDA Drive HW Version
25	0x2001.0	DDA Motor HW Version
26	0x6410.1	DDA Nominal Speed
27	0x6410.2	DDA Nominal Voltage
28	0x6075.0 0x6410.3	DDA Nom. Motor Current
29	0x6410.4	DDA Max Motor Current
30	0x6510.1	DDA Max Drive Current
31	0x6076.0	DDA Nominal Torque
32	0x6064.6-7	DDA Min/Max Voltage
33		DDA Motor Calibration Date (String)
34	0x6406.0	DDA Motor Calibration Date (TIME_OF_DAY)
35	0x6410.5	DDA Torque Constant
36		DDA Loss Speed
37		DDA Loss Current
50	0x6040.0	DRV Control Word
51	0x6041.0	DRV Status Word
52		DRV Command
53		DRV State
54	0x1003.0	DRV Error Stack
55	0x6060.0	DRV Mode Selector
56	0x6061.0	DRV Mode Display
57	0x607E.0	DRV Polarity
58	0x1002.0	DRV Manu. Status Register

Parameter ID	CAN ID/index	Parameter Name
59		DRV Status LEDs
60	0x211B.1-10	DRV Error Accu
61	0x211C.1-10	DRV Error Accu Counter
62	0x2122.0	DRV Settings
70	0x2116.1-2	POS UU Ratio
71	0x607A.0	POS Target Position
72	0x607F.0	POS Max. Velocity
73	0x60C5.0	POS Max. Acceleration
74	0x60C6.0	POS Max. Deceleration
75	0x6081.0 0x2004.1-10	POS Profile Velocity
76	0x6083.0 0x2005.1-10	POS Acceleration
77	0x6084.0 0x2006.1-10	POS Deceleration
78	0x2007.0	POS Current Index
79		POS Current Position
80		POS
81	0x60FF.0 0x2121.1-10	POS Target Velocity
82	0x606C.0	POS Actual Velocity
90	0x6063.0	PCT Position Actual Value *
91	0x6064.0	PCT Position Actual Value
92	0x6067.0	PCT Position Window
93	0x6068.0	PCT Position Window Time
94	0x211A.1-2	PCT Control Window
95	0x60F4.0	PCT Following Error
96	0x6065.0	PCT Following Window
110	0x6098.0	HOM Homing Method
111	0x6099.1	HOM Homing Speed
112	0x2008.1-2	HOM SW Pos. Safety Limit
113	0x2009.1-2	HOM SW Position Drive Limit
114	0x607D.1-2	HOM SW Position Limit
115	0x200B.0	HOM Pos. Assignment Value
130	0x2011.2 0x6042.0	VEL Target
131	0x2011.3 0x6048.1	VEL Acceleration
132	0x2011.4 0x6049.1	VEL Deceleration

Parameter ID	CAN ID/index	Parameter Name
133	0x607E.0	VEL Polarity
134	0x606D	VEL Window
135	0x606E	VEL Window Time
140	0x6071.0	TOR Target Torque
141	0x6087.0	TOR Torque Slope
142		TOR Torque Current
180	0x2115.0	ENC Lines
181	0x2010.9 0x608F.1	ENC Resolution
182		ENC Position
183		ENC Motor Position
184	0x6044.0 0x6043.0 0x6080.0 0x6069.0	ENC Speed
185	0x6046.1-2 0x211E.0	ENC Speed Limit
186	0x2117.0	ENC Position Limit
187	0x6091.1-2 0x6510.4-5	ENC Gear Ratio
188	0x2114.0	ENC Stagnation Limit
189		ENC Ref. Motor Position
190	0x2115.0	ENC Motor Position Error
191	0x2010.9	ENC Filter
200		CTL Reference
201	0x2010.2	CTL Prop. Gain
202	0x2010.4	CTL Integ. Time
203	0x2010.5	CTL System Gain
204	0x2010.1	CTL Position Gain
205	0x2010.3/6	CTL Position Pre Factor
206	0x606B.0	CTL Set Value
220	0x2118.0	POW Duty Cycle
221	0x2010.7	POW Prop. Gain
222	0x2010.8	POW Integ. Time
223		POW Current Set Value
224	0x6078.0	POW Current Act Value
225	0x2011.5-6	POW Current Max Mot/Gen
226		POW Hall Pattern
227	0x2119.1-2	POW Max Duty Cycle

Parameter ID	CAN ID/index	Parameter Name
228	0x2111.0	POW I ² t Value
229	0x2112.1-2	POW I ² t Limit
230	0x2113.0	POW I ² t Delay Time
231	0x211D.0	POW Brake Speed
232		POW Brake Voltage
233		POW Current Offset
240		IO Analogue Register
241	0x60FD.0	IO Digital Inputs
242		IO Analogue Input 1
244	0x200D.1-2	IO Temperature
245	0x2110.1-4 0x6510.2-3	IO Temp. Limit
246		IO Frequency Output
247	0x6079.0	IO DC Voltage
260		CAN State
261		CAN Node ID
262		CAN Bittate
263	0x100C.0	CAN Guardtime
264	0c100D.0	CAN
265		CAN Load
280	0x1010.1-3 0x1011.1-3	MEM Command
281		MEM ID
282		MEM Error
283	0x200E.1-5	MEM Drive Logbook
284		MEM Drive Logbook Backup
285		MEM Par.Set Number
300		ACT ...

6 Fault List

The DRV Error Stack parameter displays the number of the current fault.

Fault number	Module	Definition	Reaction
0x2200	Power	Switching fault Fault in switching from drive mode to braking, Hall sensor state is	For info only
0x2211	Power	Hall event is not correct Hall sensors are indicating the wrong state.	For info only
0x2212	Power	PWM Idle The state machine of the PWM generator is displaying errors.	Drive is switched off
0x2220	Power	Over current Bridge driver indicates over current.	Drive is switched off
0x2221	Power	Positive over current Internal current capture indicates over current. The actual current is measured in cycles. If this value exceeds a motor-based value of 35 A, the drive is shut down as soon as the fault counter POW Max Over Current overruns.	Drive is switched off
0x2222	Power	Negative over current Internal current capture indicates over current. The actual current is measured in cycles. If this value goes below a generator-based value of 20 A, the drive is shut down as soon as the fault counter POW Max Over Current overruns.	Drive is switched off
0x2300	Power	I ² t monitoring Warning limit of POW I ² t Limit parameter has been exceeded	For info only
0x2310	Power	I ² t monitoring Warning limit of POW I ² t Limit parameter has been exceeded	Drive is switched off

Fault number	Module	Definition	Reaction
0x3120	InOut	Power fail input has responded while drive is active. The input voltage was below 12 (16) volts.	Drive was switched off, Log book was stored.
0x3121	InOut	Power fail input has responded while drive is inactive. Input voltage was below 12 V	For info only Log book was stored.
0x3210	InOut	Overvoltage The measured voltage was larger than the permissible maximum value of the nominal voltage range. See IO DC Voltage parameter, DDA Min/Max Voltage	Drive is switched off
0x3220	InOut	Under voltage. The measured voltage was smaller than the minimum permissible value of the nominal voltage range. See IO DC Voltage parameter, DDA Min/Max Voltage	Drive is switched off
0x4200	Temp.	Over temperature warning for controller component. The threshold value can be set using the IO Temp Limit parameter.	For info only
0x4210	Temp.	Over temperature shutdown for controller component The threshold value can be set using the IO Temp Limit parameter.	Drive is switched off
0x4300	In/Out	Motor over temperature The over temperature switch in the motor has been triggered.	Drive is switched off
0x4400	Temp.	Over temperature warning for power component The threshold value can be set using the IO Temp Limit parameter.	For info only
0x4410	Temp.	Over temperature shutdown for power component The threshold value can be set using the IO Temp Limit parameter.	Drive is switched off

Fault number	Module	Definition	Reaction
0x7120	Velocity	Motor is blocked The drive ran at the current limit for a longer time than specified in the VEL Block Protection parameter.	Drive is switched off
0x7121	Encoder	Motor is blocked The ENC Speed Limit min/max/dif parameter defines the maximum permissible speed deviation. This value was exceeded.	Drive is switched off
0x7310	Encoder	Over speed The actual speed has exceeded the value set in the ENC Speed Limit parameter.	Drive is switched off
0x8110	CAN	CAN bus overrun, data may be lost along the bus.	For info only
0x8120	CAN	CAN Open module in passive mode, CAN bus cannot find remote station for drive.	For info only
0x8130	CAN	Fault in monitoring lifeguard or heartbeat on CAN bus. (Lifeguard, Heartbeat)	Drive is switched off
0x8611	Encoder	Following error The actual position deviation has exceeded the value set in the ENC Position Limit parameter. This monitoring feature is only active when position controlling is enabled (CTL Position Gain CTL Position Gain parameter).	Drive is switched off
0xff01	In/Output	Input for controller enable The digital input for controller enable has been shut off.	Drive is switched off
0xff02	In/Output	Input for controller enable The digital input for controller enable must be set to switch on.	Drive is not switched on
0xff03	In/Output	Bridge driver The driver module indicates a fault.	Drive is switched off
0xff05	Power	Hall sensor fault No valid Hall state could be detected at switch-on	Drive is not switched on

Fault number	Module	Definition	Reaction
0xff06	Power	Current compensation Current compensation still active at switch-on.	Drive is not switched on
0xff07	Drive	Switch-on during invalid operating mode, see DRV Mode Selector	Drive is not switched on
0xff08	Drive	Operating mode cannot be changed while drive is switched on, see DRV Mode Selector	Operating mode is not changed
0xff10	System	Process system overrun	Drive is switched off
0xff11	System	Processor fault, stack overflow	Drive is switched off
0xff12	System	Processor fault, stack underflow	Drive is switched off
0xff13	System	Processor fault, B-trap	Drive is switched off
0xff14	System	Processor fault, undefined OP-code	Drive is switched off
0xff15	System	Processor fault, protection fault	Drive is switched off
0xff16	System	Processor fault, illegal operand	Drive is switched off
0xff17	System	Processor fault, illegal command	Drive is switched off
0xff18	System	Processor fault, illegal bus access	Drive is switched off
0xff19	System	CRC via code range not OK	Drive must be replaced
0xff1a	System	Irreversible fault has occurred.	Drive must be replaced
0xff1b	System	Program access fault (PACER)	Drive must be replaced
0xff21	Prof. Pos.	Speed of actual approach set in POS Profile Velocity parameter is not within limits of ENC Speed Limit min/max/dif parameter.	For info only Positioning does not start
0xff22	Prof. Pos.	Target position invalid	For info only Positioning does not start

Fault number	Module	Definition	Reaction
0xff23	Prof. Pos.	Start and/or target position not within work area	For info only Positioning does not start
0xff24	Prof. Pos.	Command not supported	For info only
0xff25	Prof. Pos.	New positioning process not possible while previous positioning procedure still running.	For info only
0xff26	Prof. Pos.	General fault	For info only
0xff27	Prof. Pos.	Drive was not referenced	For info only, positioning does not start
0xff28	Prof. Pos.	<ul style="list-style-type: none"> • Drive outside of limits during approach. • Drive not within traversing range during switch on 	Drive is switched off
0xff30	Homing	Value can be written exclusively in homing mode	For info only
0xff31	Homing	Fault in limits	For info only
0xff32	Homing	New position does not lie within work area	For info only
0xff33	Homing	Homing not allowed when drive is turned on	For info only
0xff34	Homing	Conversion of UU to increments not possible for entire range. Increase value in POS UU Ratio parameter.	For info only
0xff40	MEM	EEPROM full	For info only
0xff41	MEM	EEPROM CRC Fault	For info only
0xff42	MEM	EEPROM timeout	For info only
0xff43	MEM	New parameter, not compatible. Eliminate: Store all parameters	For info only
0xff44	MEM	Write fault parameter	For info only
0xff45	MEM	Read fault parameter	For info only
0xff46	MEM	Parameter fault in attribute	For info only
0xff47	MEM	Write protection fault	For info only
0xff48	MEM	General fault	For info only
0xff60	LEQ	LevaQuell, wrong operating mode selected.	For info only