

MULTITEL



MJ420



- Commandes électro-hydrauliques proportionnelles avec la possibilité de réglage de la vitesse de tous les mouvements, aussi bien du sol que de la nacelle.
- Système électronique de limitation de vitesse en fonction du développement de l'élévateur.
- Amortissement automatique en approche de butée de mouvement.
- Possibilité d'effectuer tous les mouvements de façon simultanée.
- Mesure de la charge embarquée en nacelle, avec dispositif anti surcharge.
- Panier extensible hydrauliquement.
- Sortie hydraulique des éléments télescopiques du bras.
- Chemins de câbles internes au bras.
- Clapets anti-retour sur tous les mouvements.



- Proportional electro-hydraulic controls from both control posts.
- Electronic speed limiting device according to the extension of the boom.
- Electronic damping of the speed at final positions.
- Possibility of several contemporary manoeuvres.
- Load sensing device on the cage with overload device.
- Hydraulically extendible cage.
- Synchronous multi-stage telescope cylinders.
- Internal hose and cable ducts.
- Hydraulic check valves on all movements.



- Elektro-Hydraulische Proportionalsteuerung mit Geschwindigkeitsregelung für alle Funktionen, von Korb- und Bodenbedienung.
- Elektronische Geschwindigkeitsselbstbegrenzung abhängig von dem Teleskopsausfahren.
- Elektronische Geschwindigkeitsdämpfung am Ende sämtlicher Schaltungen.
- Möglichkeit mehrerer gleichzeitiger Bedienungen.
- Kontrolle der Tragfähigkeit des Arbeitskorbes mit Lastmomentbegrenzung.
- Hydraulisch verlängerbarer Arbeitskorb.
- Synchron-ausfahrende Mehrstufen Teleskop-Zylinder.
- Innenliegende Kabel- und Schlauchverlegung.
- Hydraulische Sperrventile auf jede Bewegung.



- Comando elettroidraulico proporzionale con regolazione della velocità di tutti i movimenti sia dal cestello che da terra
- Sistema elettronico di autolimitazione della velocità in funzione dell'estensione dei bracci
- Ammortizzazione elettronica della velocità a fine manovra
- Possibilità di effettuare più manovre contemporaneamente
- Lettura del carico sul cestello con dispositivo antisovraccarico
- Cestello estensibile idraulicamente
- Uscita oleodinamica degli sfili telescopici dei bracci
- Tubi e cavi installati all'interno dei bracci
- Valvole di blocco su ogni movimento.

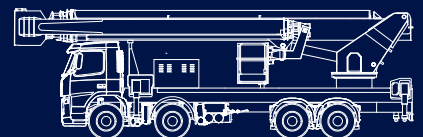
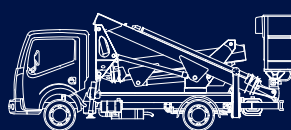
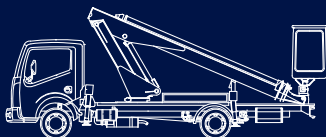



MJ420

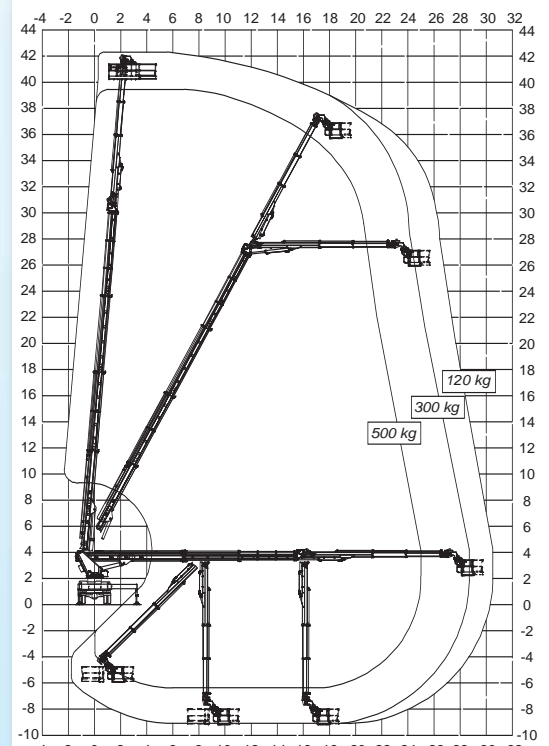
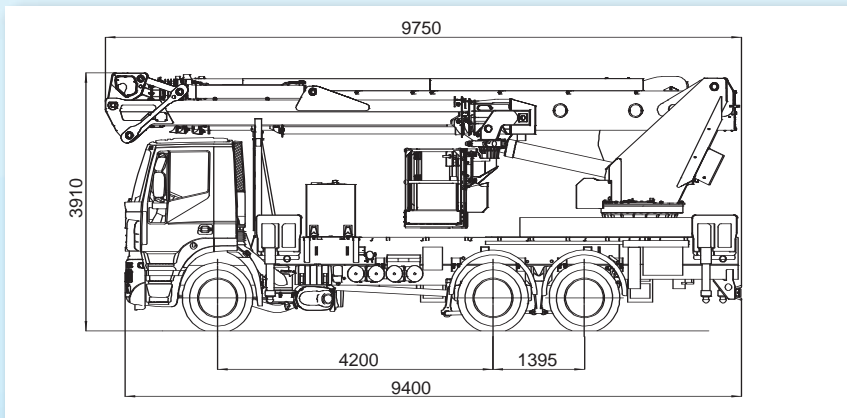

Charge utile en nacelle	Safe working load on cage	Tragfähigkeit	Portata cestello	120 kg	300 kg	500 kg
Hauteur de travail env.	Max working height	Maximale Arbeitshöhe	Altezza max di lavoro	42,30 m	42,30 m	39,40 m
Hauteur plancher nacelle env.	Maximum platform height	Maximale Plattformhöhe	Altezza piano calpestio cestello	40,30 m	40,30 m	37,40 m
Déport maxi de travail env.	Max working outreach	Maximale seitliche Reichweite	Sbraccio max di lavoro	30,50 m	28,70 m	25,00 m
Rotation de la tourelle (continus)	Turret rotation (continuous)	Schwenkbereich (endlos)	Rotazione torretta (continui)	360°		
Rotation de la nacelle	Cage rotation	Hydraulische Korbdrehung	Rotazione idraulica del cestello	180°+180°		
Sortie télescopique des bras env.	Boom telescopic amplitude	Teleskopaus Schub	Escursione telescopica dei bracci	22,60 m		
Angle d'articulation du pendulaire	Rotation angle of the 2° boom	Drehwinkel des Gelenkauslegers	Angolo di articolazione 2° braccio	180°		
Dimensions nacelle	Cage dimensions	Arbeitskorbabmessungen: LxBxH	Dimensioni del cestello	2,50/3,60 x 0,90 x 1,10 m		



Barcelona
938498388

Madrid
918951758

Valencia
961344538

Vitoria
945365601