

**Document Class 1**

## AMP+ Low-Medium Current Connector HVA630-2phm V0

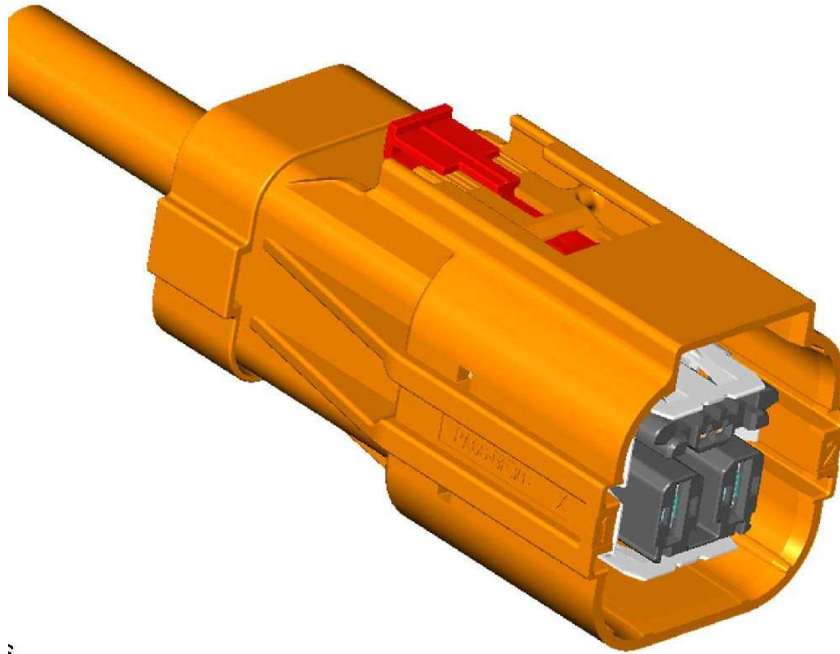

**Content**

<b>1.</b>	<b>Scope</b> .....	<b>2</b>
<b>2.</b>	<b>Processing Note</b> .....	<b>2</b>
2.1	TE Connectivity Documentation .....	2
2.2	General Documentation.....	3
<b>3.</b>	<b>Application Tools</b> .....	<b>4</b>
<b>4.</b>	<b>Assembly Instructions</b> .....	<b>4</b>
4.1	Assembly overview.....	4
4.2	Parts of Assembly to order .....	5
4.3	Security Advice .....	6
4.4	Assembly Steps .....	7
4.5	End of Line Test.....	15
<b>5.</b>	<b>Header Connector mounting</b> .....	<b>16</b>
<b>6.</b>	<b>Connector handling</b> .....	<b>17</b>
6.1	Plugging Connector.....	17
6.2	Unplugging Connector .....	17

**1. SCOPE**

This specification describes the assembly of the 2 pos. HV Connector HVA630 2phm. This specification applies to hand-assembly of the coupling.

**2. PROCESSING NOTE**

The following technical documents, if referred to, are part of this specification. In case of a contradiction between this specification and the product drawing or this specification and the specified documentation then the product specification has priority.

The processor is responsible for ensuring the quality of the manufacturing process and the proper function of the system. The warranty and liability is excluded if quality deficiency or damages occurs by failing compliance to this specification or using not specified, not released tools and connector components.

The assembly should only be performed by trained personnel.

**2.1 TE Connectivity Documentation****a) Customer drawings**

2334437	HV CONNECTOR KIT, 2 POS. V0
2328732	PLUG HOUSING ASSY, HV CONN
2328730	RECEPTACLE HSG, ASSY, HV CONNECTOR
2332013	SHIELD CRIMP FERRULE, INNER
2331718	SHIELDING, HV CONNECTOR, 2 POS
2332014	OUTER CRIMP FERRULE, HV-CONNECTOR
2332016	CABLE SEAL, HV CONNECTOR, 2 POS
2328731	COVER
2328746	180 DEG TAB HEADER ASSY

**b) Specifications**

108-101675	Product Specification HVA630-2phm
114-18388	Application Specification AMP MCP 6.3/4.8K Contact
109-18212	Shield and Insulation Crimp Validation for HV Applications

**2.2 General Documentation****a) Cable specifications of prescribed cables****Cross-section                      2x4.0mm<sup>2</sup>**

Supplier: Coroplast Fritz Müller GmbH & Co. KG,  
D-42279 Wuppertal

Outer Diameter :	11,3 -0,6 mm
Cable Description ::	<i>FHLR2GCB2G 2 x 4,0 mm<sup>2</sup> / T180</i>
Coroplast Part No.:	9-2641 (2x4.0mm <sup>2</sup> ) / A8 / 2012-12-08
TE Part No.:	2177114-1 Rev.A

**Cross-section                      2x6.0mm<sup>2</sup>**

Supplier : Coroplast Fritz Müller GmbH & Co. KG,  
D-42279 Wuppertal

Outer Diameter	12,8 -0,6 mm
Cable Description	<i>FHLR2GCB2G 2 x 6,0 mm<sup>2</sup> / T180</i>
Coroplast Part No.:	9-2641 (2x6.0mm <sup>2</sup> ) / A5 / 2012-12-04
TE Part No.:	2177115-1 Rev.A

**NOTE: Coroplast as cable released vendor for this product.  
Don't recorded to use other vendor if not being released**

3. APPLICATION TOOLS

Required application tools

Application device	P/N:	Description:
AMP MCP 6.3/4.8K Contact (4-6mm <sup>2</sup> )	See Application Specification 114-18388	
Shield crimp, 2pos. (2x4mm <sup>2</sup> )	528041-9 Rev.C2	Die Set, Locator HVA630-2phm, 4.0mm <sup>2</sup>
	541868-1	AT66 Die set adapter HV
	528008-4	HV Crimping Machine, speed 10mm/sec
Shield crimp, 2pos. (2x6mm <sup>2</sup> )	1-528041-0 Rev.C1	Die Set, Locator HVA630-2phm, 6.0mm <sup>2</sup>
	541868-1	AT66 Die set adapter HV
	528008-4	HV Crimping Machine, speed 10mm/sec

Table

4. ASSEMBLY INSTRUCTIONS

4.1 Assembly overview

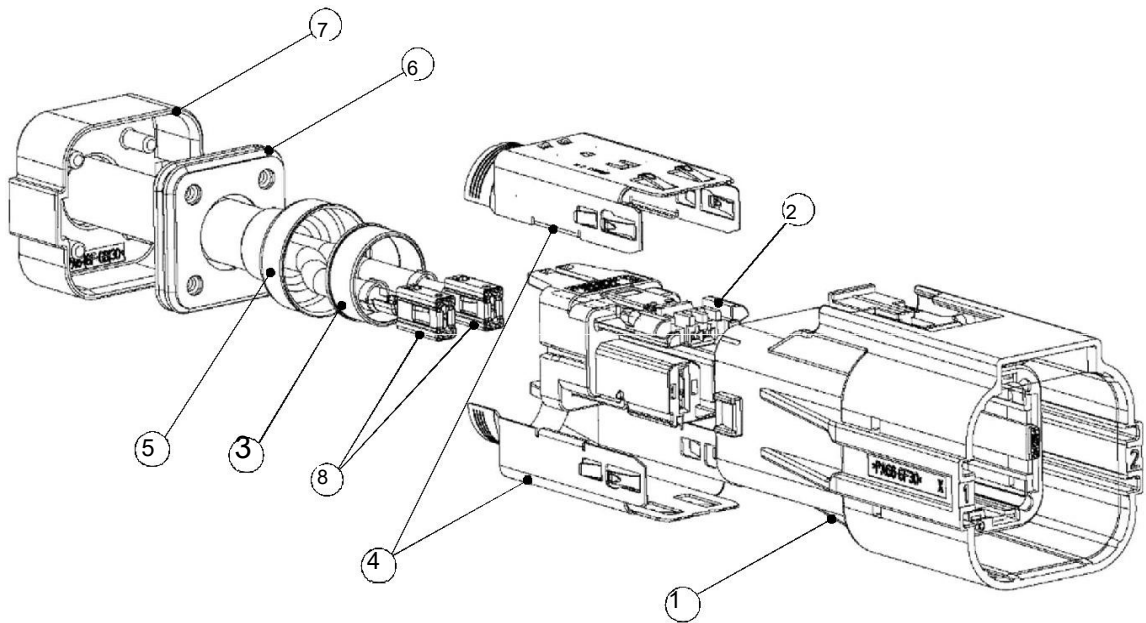

Figure 1

## 4.2 Parts of Assembly to order

Wire			2×4mm <sup>2</sup>	2×6mm <sup>2</sup>
Part				
POS.	QTY.	Name	P/N	
1	1	PLUG HOUSING ASSY, CODE	2328732-X	2328732-X
2	1	RECEPTACLE HOUSING ASSY	2328730-1	2328730-1
3	1	SHIELD CRIMP FERRULE, INNER	2332013-1	2332013-1
4	2	SHIELDING	2331718-1	2331718-1
5	1	OUTER CRIMP FERRULE	2332014-3	2332014-4
6	1	CABLE SEAL	2332016-3	2332016-4
7	1	COVER	2328731-3	2328731-4
8	2	AMP MCP 6.3/4.8 CONTACT	STRIP 2-1241408-3	STRIP 2-1241408-3

4.3 Security Advice

**ATTENTION!  
- HIGH VOLTAGE APPLICATION -  
SHIELDING BRAID AND CABLE INSULATION  
MAY NOT BE DAMAGED!**

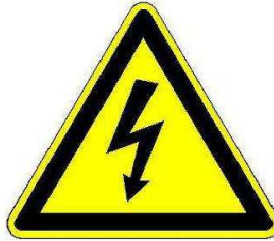

The assembly should only be performed by trained personnel.

Avoid prolonged or repeated skin contact with shielding. (wear protective gloves)

**4.4 Assembly Steps****Step 1**

The following parts must be assembled in the following order on the cable (Figure 2).

- 1. COVER**
- 2. CABLE SEAL**
- 3. OUTER CRIMP FERRULE**

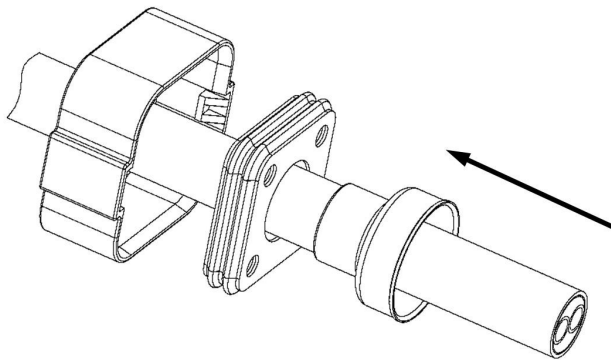
**Figure 2****Step 2**

Remove wire sheath material as shown:

Remove outer sheath and foiled shielding according to determined length. (Figure 3)

Shorten shielding braid and filler. The shielding braid has to be combed out (brushed out). Cutting length of combed out shielding braid and filler adjusted to  $15\pm 1$ mm (Figure 3).

Fold the shielding braid back. (Figure 4)

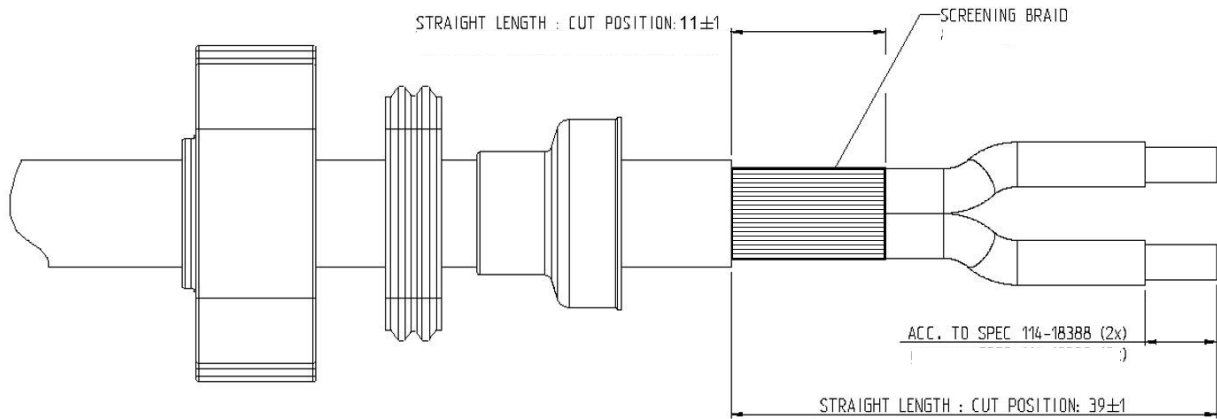
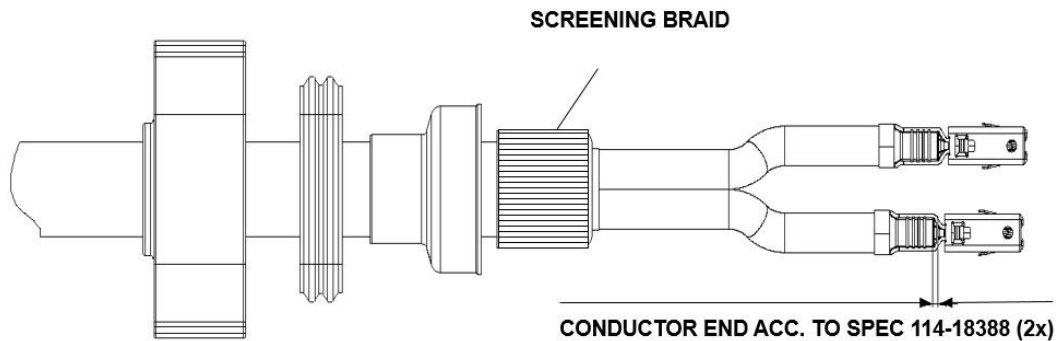

**Figure 3**

**Step 3**

Remove core insulation according to spec. 114-18388 (Figure 3)

Crimp on all conductors AMP MCP 6.3/4.8K contact with the specified tool according to TE SPEC. 114-18388. Avoid twisting of the conductors. For easy insertion into RECEPTACLE HOUSING all should have the same orientation (Figure 4).



**Figure 4**

**Step 4**

Assemble INNER CRIMP FERRULE on the cable (Figure 5).

**CAUTION: Ensure correct orientation!**



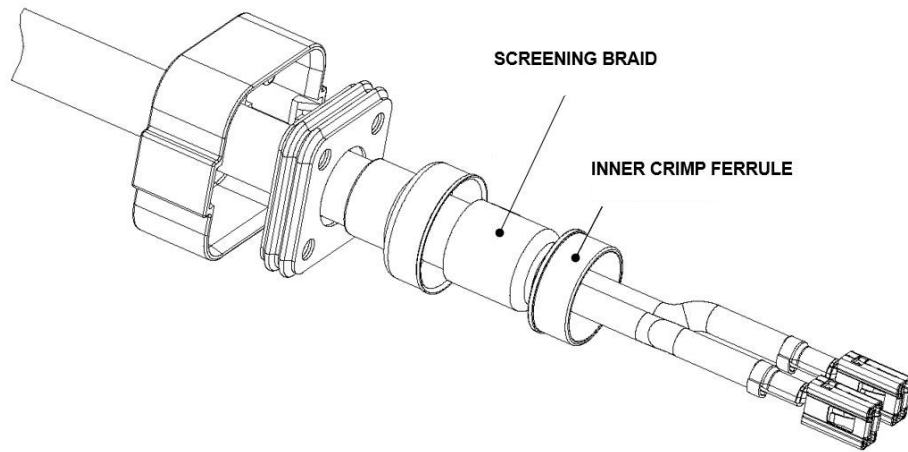

Figure 5

**Step 5**

Insert the Contacts into the RECEPTACLE HOUSING (according to the cavity numbers shown in Figure 6) into their locking position. The contacts are locked when a click is heard on insertion. To ensure that the contacts are correctly inserted, push/pull with a force on the cables (max. 10N). After the contacts have been controlled for correct positioning and locking, the secondary lock of the RECEPTACLE HOUSING have to be locked (Figure 7). The adequate locking is audible (snap in), but must be controlled by visual inspection.

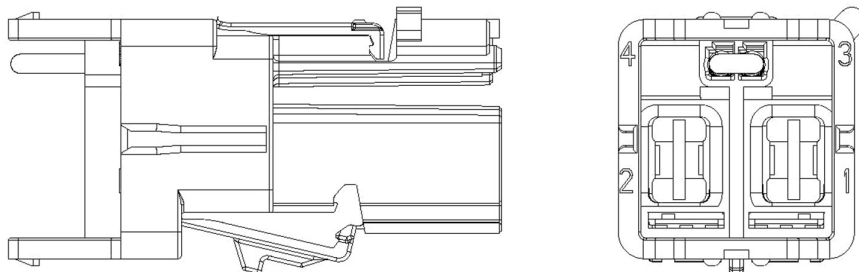

Figure 6

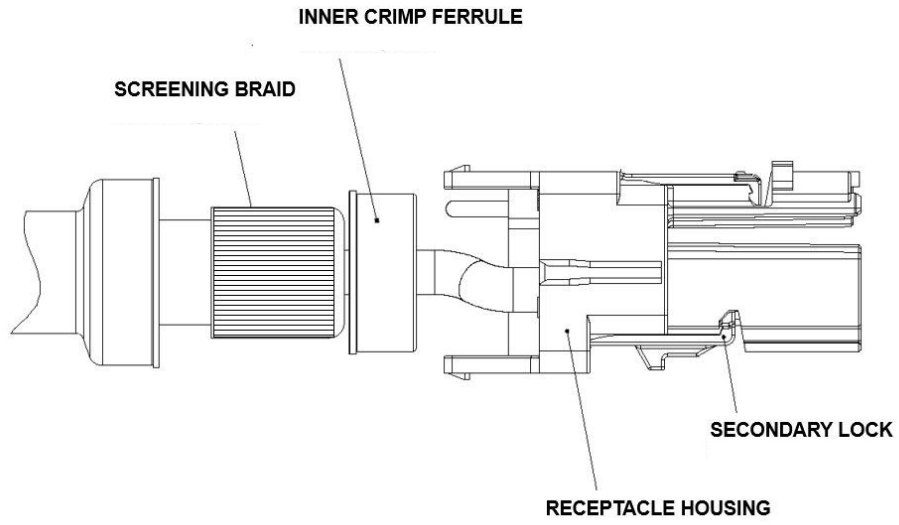
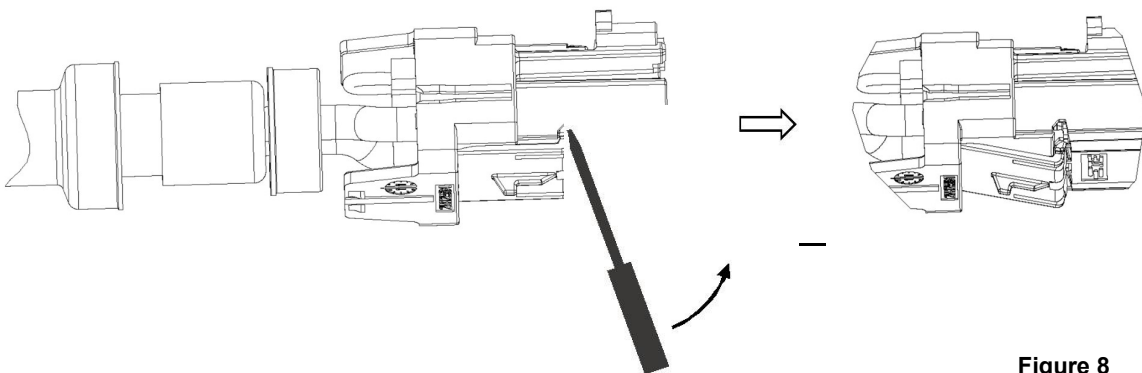

Figure 7

**Note:** If a dismounting of AMP MCP6.3/4.8K-contact is necessary use auxiliary tool according contact specification 114-18388. For opening the secondary locks use a flat screwdriver (e.g. 2.3x0.5) (Figure 8). If a secondary lock has been opened the RECEPTACLE HOUSING has to be exchanged.



**Step 6**

Position the **INNER CRIMP FERRULE** next to the **SHIELDING BRAID** (Figure 9).

Slide first **SHIELD** on the **RECEPTACLE HOUSING** until it snaps on it (Figure 9).

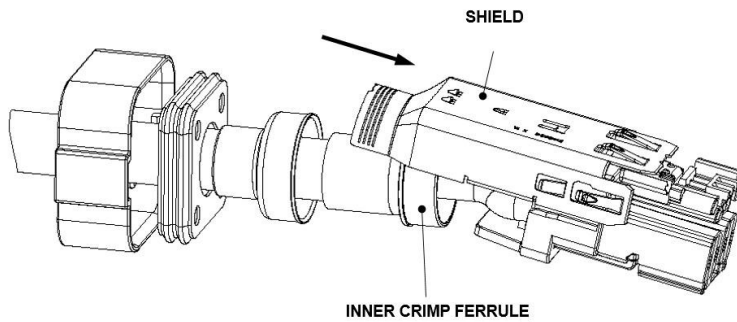
**Figure 9**

Slide second **SHIELD** on the **RECEPTACLE HOUSING** until it stops (Figure 10).

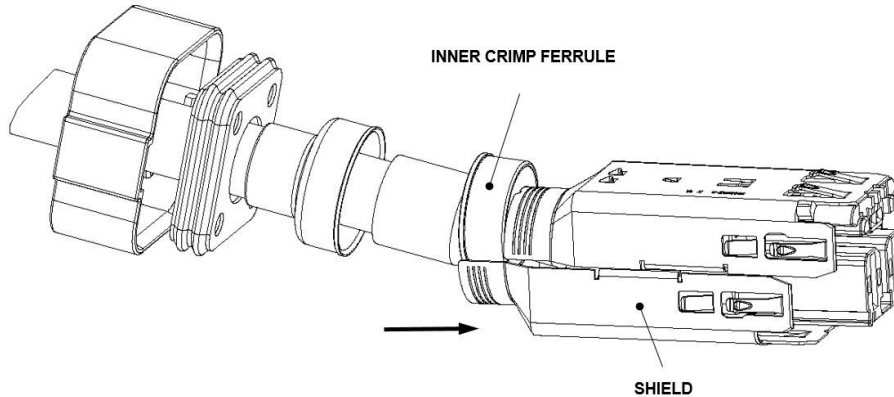
**Figure 10**

Position the **INNER CRIMP FERRULE** into the **SHIELDS** until it lies against the end of the **SHIELDS** (Figure 11).

Put the **SHIELDING BRAID** over the **SHIELDS** (Figure 11).

Push the **OUTER CRIMP FERRULE** over the **SCREENING BRAID** and the **SHIELDS** (Figure 11).

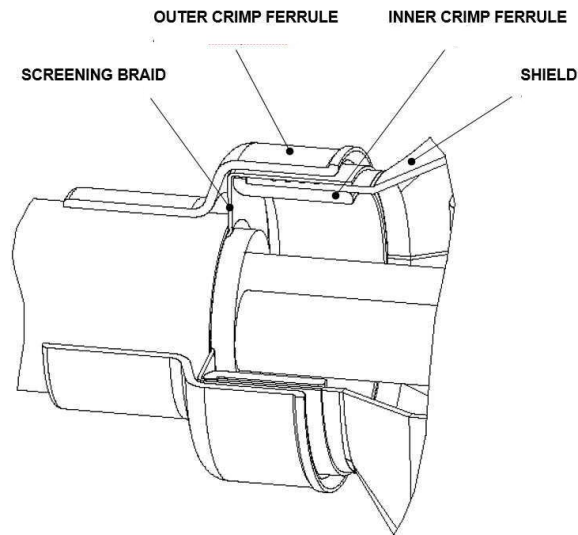
**Figure 11****Step 7**

**Ensure that all parts are in the correct position (Figure 12). Ensure that the shield braids are homogeneous spread over the circumference of the crimp ferrule. Insert the Assembly into the Die Set with locator and crimp it. For correct handling and using of application tools see guideline 411-18555.**

**After crimping the shield braid has to be visible for visual inspection of homogeneous distribution of the braids and may extend according Figure 12. CAUTION: Post crimp cutting of the braids is not permitted !**

**The crimp quality has to be conformed to TE Spec. 109-18212. The crimp heights have to be measured according Chapter 5.4 of TE Spec. 109-18212 and they have to meet following requirements:**

Measuring points in plane of embossing

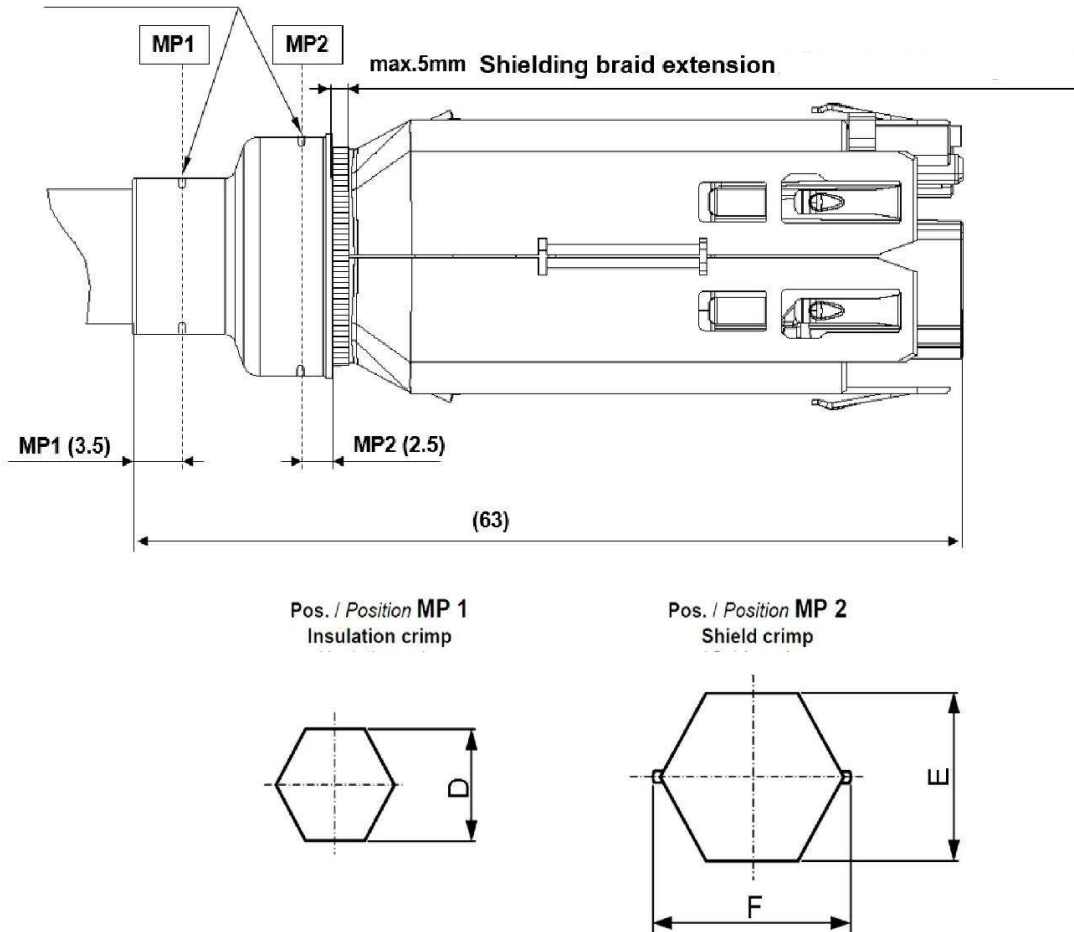

Figure 12

Cross section	D [mm]	E [mm]	F [mm]	G * [mm]
2x4mm <sup>2</sup>	11,6 ± 0,15	15,8 ± 0,15	max. 20	max. 13,0
2x6mm <sup>2</sup>	13.0 ± 0,15			max. 14,6

Table 3

\* Dim G = recommended inspection dimension against mistaken identity of outer crimp ferule \*

**Step 8**

Insert the Multicore Shielded Cable Assembly into the OUTER HOUSING ASSEMBLY. The Receptacle Housing ensures with its coding the correct polarisation in the Outer Housing Assembly (Figure 13). To ensure that the Cable Assy is correctly snapped in, pull with a force on the cable (max. 10N).

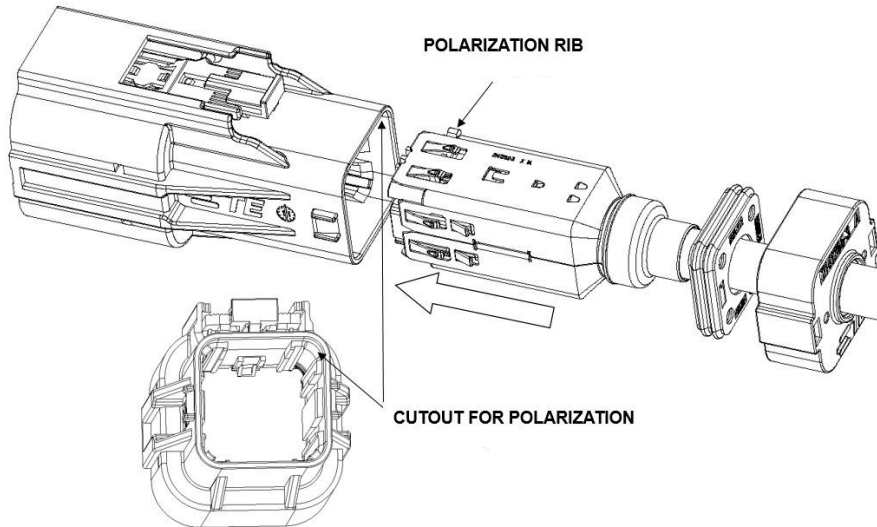

Figure 13

**Step 9**

Join COVER and CABLE SEAL together, the 4 CENTERING PINS have to insert complete into the CABLE SEAL openings (Figure 14).

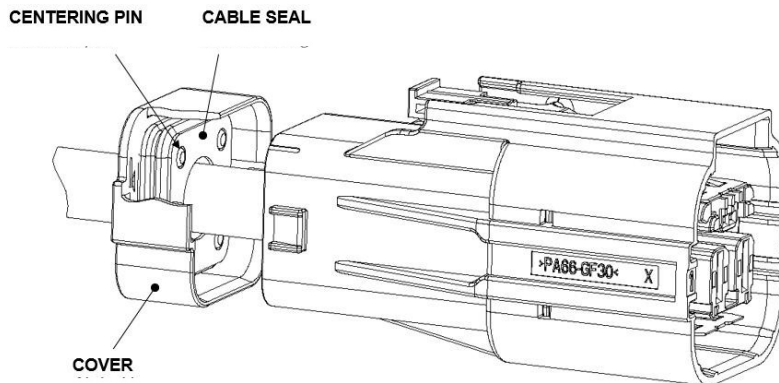

Figure14

Press the COVER over the OUTER HOUSING. Ensure that both Catch-Mechanisms are snapped in.

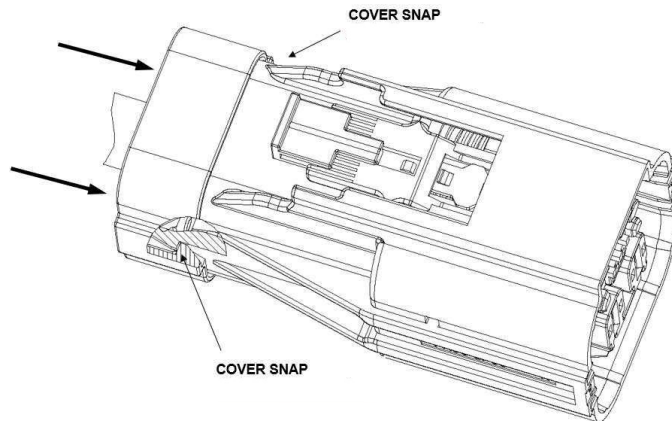

Figure 15

#### 4.5 End of Line Test

**Assembled HV Connectors have to be tested electrically and mechanically to applicable requirements.**

On COVER are CONTROL OPENINGS for detecting existence of SEAL after COVER assembling.

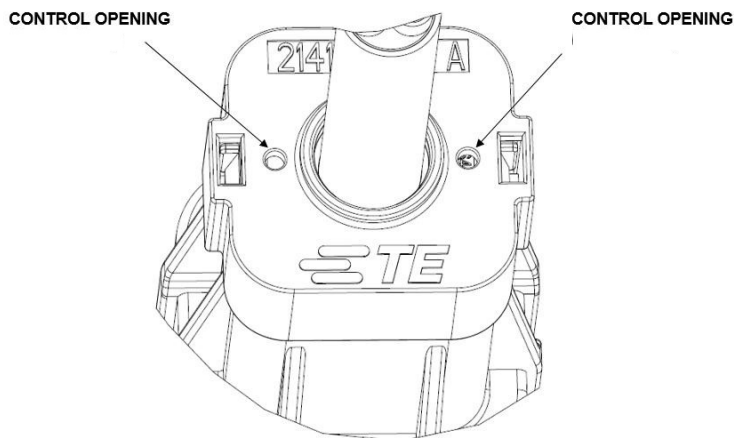
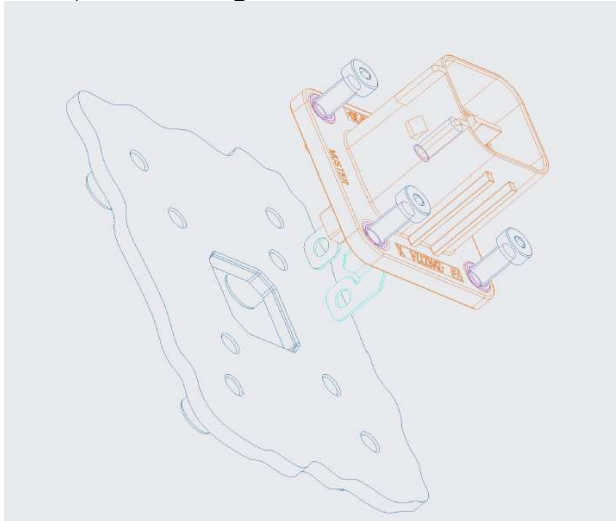

Figure 16

**5. HEADER CONNECTOR MOUNTING**

Mounting header in correct orientation with the right coding to aggregate shown in following picture.  
Mounting screw  $\Phi 5\text{mm}$  with Max screw head  $\Phi 11.5\text{mm}$ ,height 4mm,Min bearing area  $\Phi 9.5\text{mm}$ .  
Screw type up to manufacturer, drill hole design according to screw type pretension Min 6000N,Max 6400N, Refer drawing 114-94037 note 10.



Mounting header to aggregate

Figure 17

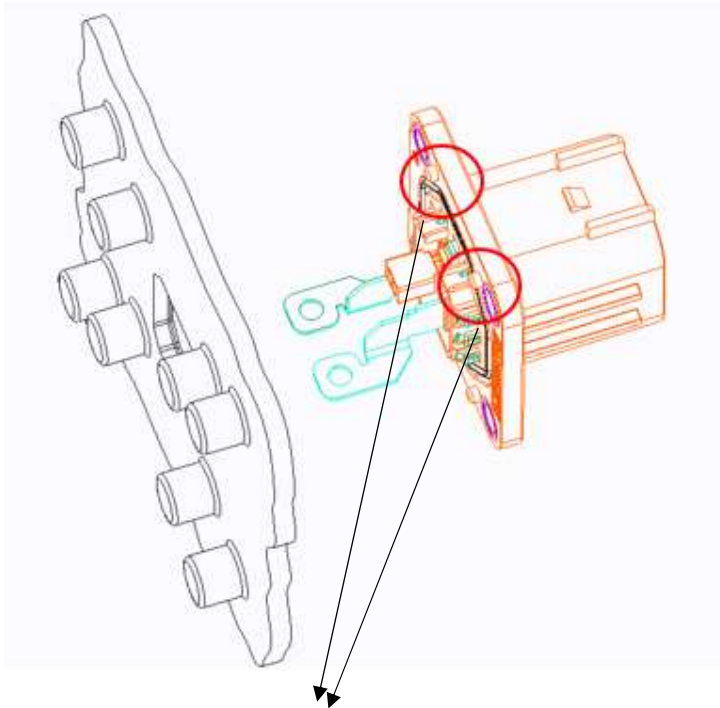

Mounting header to aggregate with the right coding

Figure 18



**6. CONNECTOR HANDLING****6.1 Plugging Connector**

- Push the plug fully until hearable snapping into the header
- Verify that the connectors are fully locked with a light tug, do not pull on the wire. If the connection is not correct plugged, it will not be able to activate the CPA.

- Push the CPA forward (see figure 19). The locking latch is in this position blocked and it will not be possible to push down the Locking latch for opening the connection.

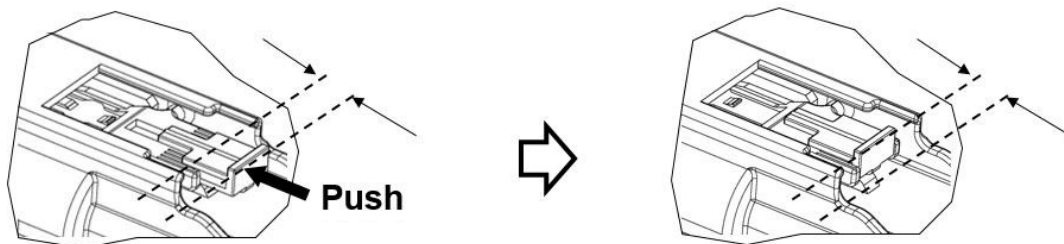
**Figure 19****6.2 Unplugging Connector**

- Pull the CPA back (see figure 20)

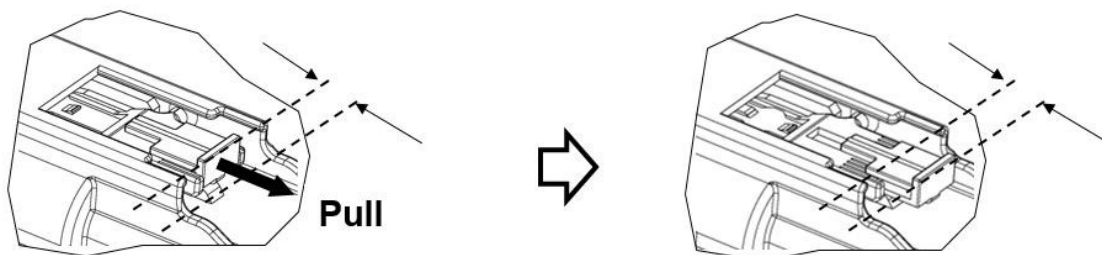
**Figure 20**

- Press the locking latch down to unlock the connector and pull the plug out of the header.  
Do not pull on the wire. (see figure 21)

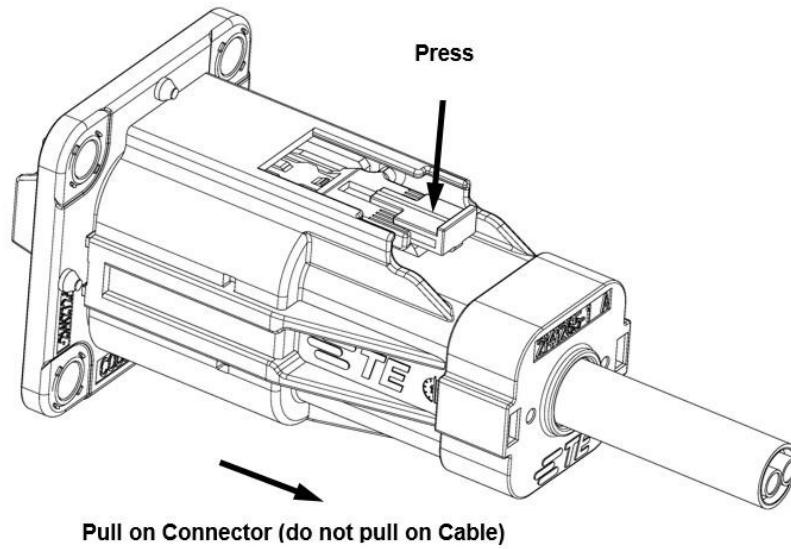

**Figure 21**

LTR	REVISION RECORD	DWN	APP	DATE
A	NEW REVISED EDITION FOR SERIES PARTS	S.XIONG	E.JIANG	16APR18
B	UPDATE HEADER MOUTING	G.XU	E.JIANG	17SEP19
B1	MODIFY COVER PN	G.XU	E.JIANG	03JAN20

DR SILVER XIONG 07JUN2018	 TE Connectivity (Shanghai) Co., Ltd HEMS/Automotive CHINA		
CHK JESSE LI 12JUN2018			
APP EVAN JIANG 14JUN2018	NO 114-101088	REV B1	LOC
TITLE	APPLICATION SPECIFICATION for HVA630 2 POS. HV CONNECTOR V0		